



IMPORTANT FOR FUTURE REFERENCE

Please complete this information and retain this manual for the life of the equipment:

Model #: _____

Serial #: _____

Date Purchased: _____

OPERATOR'S MANUAL

Electric Counter Convection Steamer

R24-3

R24-5



! WARNING

Improper installation, adjustment, alteration, service or maintenance can cause property damage, injury or death. Read the installation, operating and maintenance instructions thoroughly before installing or servicing this equipment.

1100 Old Honeycutt Road, Fuquay-Varina, NC 27526
www.southbendnc.com

INSTALLATION AND OPERATION MANUAL,
ELECTRIC COUNTER CONVECTION STEAMER, MODELS R24-3, R24-5

IMPORTANT NOTES FOR INSTALLATION AND OPERATION



This is the safety alert symbol. It is used to alert you to potential personal injury hazards. Obey all safety messages that follow this symbol to avoid possible injury or death.



WARNING: Improper installation, operation, adjustment, alteration, service or maintenance can cause property damage, injury or death. Read the installation, operating and maintenance instructions thoroughly before installing, operating or servicing this equipment.

Intended for commercial use only. Not for household use.

This manual should be retained for future reference.

INSTALLATION AND OPERATION MANUAL,
ELECTRIC COUNTER CONVECTION STEAMER, MODELS R24-3, R24-5

TABLE OF CONTENTS

DESCRIPTION	PAGE
Important Notes For Installation and Operation	2
1.0 Service Connections	4
2.0 Installation Instructions	5
3.0 Testing Procedures	10
4.0 Operation	11
5.0 Cleaning	15
6.0 Maintenance	20
7.0 Adjustment for High Altitude Locations	22
8.0 Troubleshooting	23

INSTALLATION AND OPERATION MANUAL, ELECTRIC COUNTER CONVECTION STEAMER, MODELS R24-3, R24-5

1.0 SERVICE CONNECTIONS

- ⚡ - ELECTRICAL CONNECTION: \varnothing 1 1/8" hole for electrical connection. Rating to be as specified on data plate.
- ⚡ - DRAIN: 1" IPS piped to open floor drain. No solid connection. Use copper only. 24" length before open air gap opening. (No bends or elbows)
- ⚡ - GENERATOR WATER: 3/8" O.D. tubing at 25-50 PSI(170-345 kPa)
- ⚡ - CONDENSING WATER: 3/8" O.D. tubing at 25-50 PSI(170-345 kPa)

PAN CAPACITIES

MODEL	Pan Depth			
	1" 25mm	2.5" 64mm	4" 102mm	6" 152mm
R24-3	6	3	2	1
R24-5	10	5	3	2

Model	Shipping Wt.	Min. Clearance	
R24-3	141 lbs. [64 kg]	SIDES	0
R24-5	169 lbs. [77 kg]	BACK	0

kW REQUIREMENTS

MODEL	kW
R24-3	7.5 STANDARD
	10 OPTIONAL
R24-5	12 STANDARD
	15 OPTIOANL

AMPS/PHASE

kW	SINGLE PHASE			THREE PHASE						
	208	220	240	208	220	240	380	415	480	600
7.5	36	34	31	21	20	18	12	11	9	8
10	48	46	42	28	27	24	16	14	12	10
12	58	55	50	34	32	29	19	17	15	12
15	72	69	63	42	40	36	23	21	18	15

WATER QUALITY STATEMENT

Water quality is the major factor affecting the performance of your appliance. If you are unsure of water quality, consult a local water treatment specialist and have the water analyzed. Your water supply must be within these general guidelines:

Total dissolved solids	Less than 60 PPM
Total alkalinity	Less than 20 PPM
Silica	Less than 13 PPM
Chlorine	Less than 1.5 PPM
pH Factor	7.0-8.5

Water which fails to meet these standards should be treated by installation of water conditioner.

FAILURE OR MALFUNCTION OF THIS APPLIANCE DUE TO POOR WATER QUALITY IS NOT COVERED UNDER WARRANTY.

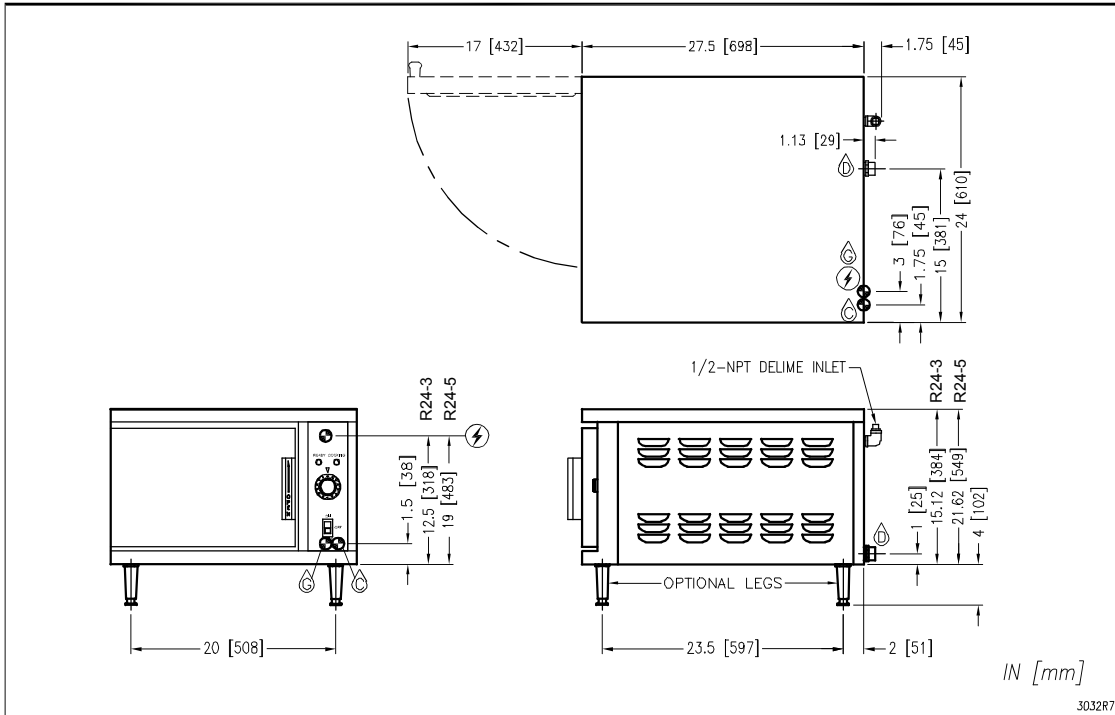

specifications are subject to change without notice.

INSTALLATION AND OPERATION MANUAL,
ELECTRIC COUNTER CONVECTION STEAMER, MODELS SX-3, SX-5

2.0 INSTALLATION INSTRUCTIONS

GENERAL

The SX-3 and SX-5 steamers are single compartment electric pressureless steam cookers with an internal electric steam generator that maintains water temperature at approximately 205°F. SX-3 is rated 7.5 kW as standard; 10 kW is optional. SX-5 is rated 12 kW as standard; 15 kW is optional.

At high altitude locations a lower temperature is required to achieve atmospheric steaming. Contact your authorized service office to have the thermostat adjusted if the steamer will be operated at high altitudes.

INSTALLATION

UNPACKING

Immediately after unpacking the steamer, check for possible shipping damage. If the steamer is found to be damaged, save the packaging material and contact the carrier within 15 days of delivery.

Prior to installation, verify that the electrical service agrees with the specifications on the machine data plate which is located on the left side panel.

LOCATION

Allow space for plumbing and electrical connections. Allow adequate access for operating and servicing the steamer (36" at the front of the steamer and 15" above the steamer).

LEGS (OPTIONAL)

If the optional 4" adjustable legs are used, remove the four levelling feet on the bottom of the steamer.

LEVELLING FEET (Standard) OR 4" ADJUSTABLE LEGS (Optional)

Thread the four 2" levelling feet shipped in a bag inside the steamer cabinet into the threaded holes on the bottom corners of the steamer. Or, thread the four optional 4" adjustable legs into the threaded holes on the bottom corners of the steamer.

INSTALLATION AND OPERATION MANUAL,
ELECTRIC COUNTER CONVECTION STEAMER, MODELS R24-3, R24-5

LEVELLING

Using a spirit level or pan of water in the bottom of the steamer, adjust the levelling feet or the feet on the adjustable legs to level the steamer front-to-back and side-to-side. After the drain is connected, check for level by pouring water onto the floor of the compartment. All water should drain through the opening at the back of the compartment cavity.

ANCHORING STEAMER (Without Legs)

1. Place steamer in the desired location on the levelled counter top and mark four corners. Remove the steamer and drill $\frac{1}{2}$ " holes as indicated in Figure 1.
2. Apply a bead of RTV or other equivalent sealant around bottom perimeter edge of the steamer. If anchoring the steamer, this bottom seal is necessary to meet NSF requirements.
3. Set steamer on counter and bolt down securely with $\frac{3}{8}$ - 16 bolts (not supplied).

STACKING KIT

Follow instructions in the stacking kit when installing stacked convection steamers.

FIGURE 1

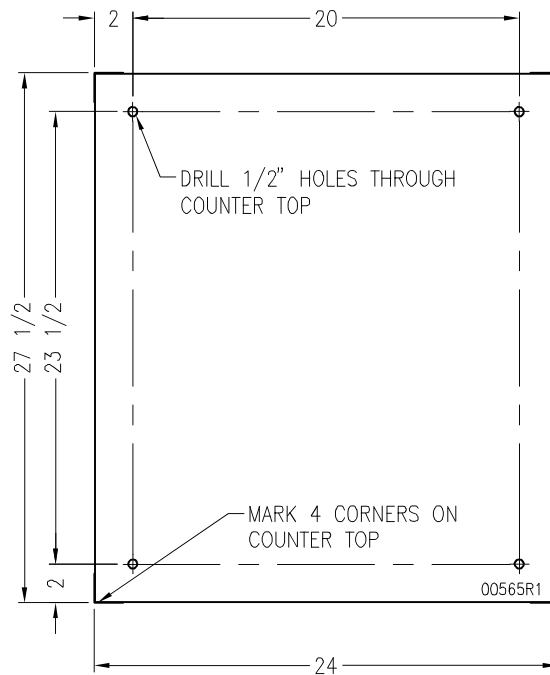

INSTALLATION AND OPERATION MANUAL,
ELECTRIC COUNTER CONVECTION STEAMER, MODELS R24-3, R24-5

PLUMBING CONNECTIONS

	WARNING: Plumbing connections must comply with applicable sanitary, safety and plumbing codes.
--	---

Connect the water supply line to the 3/8" NPT (internal thread) copper tube inlet. The 3/8" water line supplies water to both the generator tank and the cooling system where steam is condensed before entering the drain line. Should your unit have the optional split water lines, each will be marked to indicate condensate or boiler feed. The condensate feed must be cold water and the boiler feed may be either cold or hot water. Providing hot water feed to the generator will reduce recovery time during cooking. A manual shutoff valve must be provided convenient to the steamer.

DRAIN CONNECTIONS (FIGURE 2)

The drain connection (Fig. 2) must be 1" IPS down, preferably with one elbow only, maximum length of 2 feet before open air gap and piped to an open air gap type drain. Drain pipe should be copper. DO NOT use PVC pipe - PVC pipe may lose its rigidity or glue may fail.

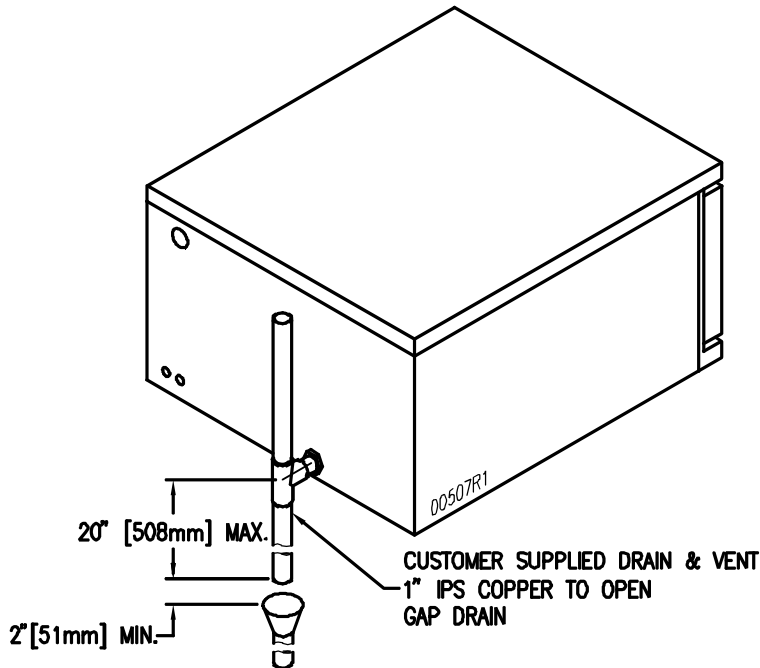

FIGURE 2

	CAUTION: In order to avoid any back pressure in the steamer, do not connect solidly to any drain connection.
--	---

INSTALLATION AND OPERATION MANUAL,
ELECTRIC COUNTER CONVECTION STEAMER, MODELS R24-3, R24-5

WATER QUALITY

The water supply connected to this steamer should contain no more than 2.0 grains of hardness per gallon with pH from 7.0 to 8.5. This degree of hardness and pH can easily be obtained with the use of a properly maintained water softener.

Water supplies vary from one location to another. A local water treatment specialist should be consulted before installing any steam generating equipment.

Untreated water contains scale producing minerals which can precipitate onto the surfaces in the boiler. Due to the temperatures in the boiler, the minerals can bake onto the surfaces and components. This can result in early component failure and reduced product life.

Mineral scale on components causes several problems:

1. The surfaces of the heating devices become coated with scale, reducing the heat transfer efficiency. This can produce hot spots on the heating elements and result in premature failure.
2. The water level probes become coated with scale. Scale will bridge across the probe insulator from the metal extension which senses the water level in the boiler cell. Once this scale becomes wet, the water level control is unable to maintain the proper water level in the boiler. This situation may cause an electric heating element to fail if the element is not adequately covered by water.

Strainers and filters will NOT remove minerals from the water.

Refer to REMOVAL OF LIME SCALE DEPOSITS, page 20.

VENT HOOD

Some local codes may require the steamer to be located under an exhaust hood. Information on the construction and installation of ventilating hoods may be obtained from Vapor Removal from Cooking Equipment, NFPA standard No. 96 (latest edition).

INSTALLATION AND OPERATION MANUAL,
ELECTRIC COUNTER CONVECTION STEAMER, MODELS R24-3, R24-5

ELECTRICAL CONNECTIONS



WARNING: Disconnect electrical power supply and place a tag at the disconnect switch to indicate that you are working on the circuit.

Electrical grounding must be provided in accordance with local codes or in the absence of local codes, with the National Electrical Code, ANSI/NFPA70, or the Canadian Electrical Code, CSA C22-2, as applicable.

Use copper wire suitable for at least 90 degrees Celsius. The steamer must be grounded. The wiring diagram is located on the right side panel as you face the steamer.

INSTALLATION AND OPERATION MANUAL,
ELECTRIC COUNTER CONVECTION STEAMER, MODELS R24-3, R24-5

3.0 TESTING PROCEDURES



CAUTION: Live steam and accumulated hot water in the compartment may be released when the door is opened.

Once the steamer is installed and all mechanical connections have been made, thoroughly test the steamer before operation.

1. Check that proper water, drain and electrical connections have been made.
2. Turn main power switch ON. After approximately 5 minutes, the READY light should come on, indicating that the water temperature is 205 degrees Fahrenheit.
3. When the READY light comes on, set timer to the "5 minute" position. With door open, observe that no steam is entering the compartment and that the COOKING light is OFF.
4. Close compartment door. The COOKING light should now be illuminated and steam should be heard entering the compartment after about 45 seconds.
5. Check drain line to ensure that water from cold water condenser is flowing through the drain line.
6. Open compartment door and observe that steam supply to chamber is cut off. (READY light should again come on as COOKING light goes off.)
7. Close compartment door and let cooking cycle finish. When the timer returns to "0" position, a buzzer will sound signalling the end of the cooking cycle. Buzzer must be manually turned off by setting the timer to its OFF position.
8. To shut down steamer, turn main power switch OFF and leave compartment door slightly open.

INSTALLATION AND OPERATION MANUAL,
ELECTRIC COUNTER CONVECTION STEAMER, MODELS R24-3, R24-5

4.0 OPERATION

When set to ON, your steamer has been factory set to maintain the generator standby temperature just below the boiling point, approximately 205 degrees Fahrenheit, in READY mode.

CONTROLS

Main Power Switch -

- ON** Boiler will automatically fill with water and begin heating to standby temperature.
- OFF** The boiler will drain.
- DELIME** Closes the drain valve while CLR liquid is being poured into the generator during the delime procedure.
- Ready Light -** When lit, indicates steam generator has reached 205 degrees Fahrenheit and is ready for the cooking cycle.
- Cooking Light -** When lit, indicates that a cooking cycle is in progress.
- Timer -** Set the cooking time (0 to 60 minutes) - steam cooking will begin when the door is closed. The cooking cycle will be interrupted if the door is opened during the cooking cycle; resume cooking by closing the door. When done, a buzzer sounds and steam stops being supplied to the cooking chamber. Turn timer OFF to stop the buzzer.

PREHEAT

Turn the main power switch ON. When the ready light comes on, set the timer to 1 minute to preheat the compartment. This should be done when the steamer is first used for the day or whenever the chamber is cold. The door should be closed during the preheat cycle. COOKING light is lit.

When the buzzer sounds, turn the timer to OFF. The steamer is now ready to cook.

INSTALLATION AND OPERATION MANUAL,
ELECTRIC COUNTER CONVECTION STEAMER, MODELS R24-3, R24-5

4.0 OPERATION (Continued)

COOK

After the preheat cycle, the READY light should be ON.

Place pans of food in the cooking chamber. Close the door. Set the timer. Steam flows into the compartment and the COOKING light is lit. Opening the door will interrupt cooking; resume by closing the door.

At the end of the cooking cycle, the COOKING light goes off, the buzzer sounds and steam stops being supplied to the cooking chamber. To stop the buzzer, turn the timer to OFF.

SHUTDOWN

Turn the main power switch OFF – the boiler will automatically blow down. Leave the compartment door open to allow the inside to dry out.

For an extended shutdown, turn the main power switch OFF, turn power and water supply OFF.

Each compartment is equipped with a removable drain screen. Frequently check the drain screen for accumulation of food particles. Should food particles accumulate against, or clog the drain screen, remove it, clean it thoroughly and then replace it in its original position.

Frequently check that the compartment drain and plumbing is free of all obstructions. Never place food containers, food or food portion bags in the cooking compartment in such a way that the compartment drain becomes obstructed.

INSTALLATION AND OPERATION MANUAL,
ELECTRIC COUNTER CONVECTION STEAMER, MODELS R24-3, R24-5

CONSTANT STEAM FEATURE - OPTIONAL FEATURE

A switch has been added to control this feature. It is located below the timer under the heading "COOKING MODE".

OPERATION WITH THIS FEATURE

Operation for Timed Cooking

This switch must be positioned to the right, towards the heading "TIMED COOKING". The operator then must select the time required for the cooking by setting the timer dial to the desired time from "0 to "60" minutes. At the end of the cook time an audible buzzer will sound.

Operation for Constant Steam

The switch must be positioned to the left towards the heading "CONTINUOUS COOKING". This mode will provide continuous steam to the cooking chamber until the operator either turns the selector switch to the "TIMED COOKING" position, or turns the power switch to the "OFF" position.

SHUT DOWN

Turn timer dial to the "OFF" position. Turn main power switch to the "OFF" position.

For an extended shutdown, turn the main power switch off, turn power and water supply off.

INSTALLATION AND OPERATION MANUAL,
ELECTRIC COUNTER CONVECTION STEAMER, MODELS R24, R-5

STEAM COOKING

Your steamer efficiently cooks vegetables or other foods for immediate serving. Steam cooking should be carefully time controlled. Keep hot-food-holding-time to a minimum to produce the most appetizing results. Prepare small batches, cook only enough to start serving, then cook additional amounts to meet demand. Separate frozen foods into smaller pieces to allow more efficient cooking.

Use a pan cover for precooked frozen dishes that cannot be cooked in the covered containers in which they are packed if they require more than 15 minutes of cooking time. When a cover is used, approximately one-third additional cooking time is necessary.

Cooking time for frozen foods depends on amount of defrosting required. If time permits, allow frozen foods to partially thaw overnight in a refrigerator. This will reduce their cooking time.

PREPARATION

Prepare vegetables, fruits, meats, seafood and poultry normally by cleaning, separating, cutting, removing stems, etc. Cook root vegetables in a perforated pan unless juices are being saved. Liquids may be collected in a solid 12 inch by 20 inch pan placed under a perforated pan. Perforated pans are used for frankfurters, wieners and similar items when juices do not need to be preserved. Solid pans are good for cooking puddings, rice and hot breakfast cereals. Vegetables and fruits are cooked in solid pans to preserve their own juices. Meats and poultry are cooked in solid pans to preserve their own juices or to retain broth. Canned foods may be heated in their opened cans (cans placed in 12 inch by 20 inch solid pans) or the contents may be poured into solid pans.

ACCEPTABLE PAN SIZES

The steamer accommodates combinations of 12" x 20" pans, solid or perforated.

Model	Number of Pans Accommodated			
	Depth of Pan			
	1"	2.5"	4"	6"
R24-3	6	3	2	1
R24-5	10	5	3	2

INSTALLATION AND OPERATION MANUAL,
ELECTRIC COUNTER CONVECTION STEAMER, MODELS R24-3, R24-5

DRAINING THE GENERATOR

Drain the steam generator after each day's use to flush out minerals and minimize scale build-up. The boiler drains automatically for about 4 to 6 minutes after the main power switch is turned off.

5.0 CLEANING

	WARNING: Disconnect the power supply to the appliance before cleaning or servicing.
---	--

	CAUTION: Do not use cleaning agents that are corrosive.
---	--

	CAUTION: The appliance and its parts are hot. Use care when operating, cleaning and servicing the appliance.
--	---

	CAUTION: Live steam and accumulated hot water in the compartment may be released when the door is opened.
---	--

At the end of each day, or between cooking cycles if necessary:

1. Turn main power switch OFF.
2. Remove pans and racks from compartment and wash in sink.
3. Wash compartment interior with clean water.
4. Use warm soapy water with a cloth or sponge to clean exposed bead of door gasket, rinse with warm clear water and wipe with a dry cloth.
5. Wipe surfaces which touch door gasket with a cloth or sponge and warm soapy water, rinse with warm clear water and wipe with a dry cloth. **Do not apply food oils or petroleum solvents or lubricants directly to door gasket or surfaces which touch door gasket.**
6. Wipe all solids away from drain opening in compartments to prevent clogging.

INSTALLATION AND OPERATION MANUAL,
ELECTRIC COUNTER CONVECTION STEAMER, MODELS R24-3, R24-5

5.0 CLEANING (Continued)

7. Keep cooking compartment drain working freely. After cooking grease producing foods, operate steam with compartment empty for 30 minutes at end of the day, or pour ½ gallon of warm soapy water down the drain, followed by ½ gallon of warm clear water.
8. Leave door slightly open when steamer is not in use.

Weekly, or more often if necessary:

Clean exterior with a damp cloth and polish with a soft dry cloth. Use a non-abrasive cleaner to remove discolourations.

	<p>CAUTION: An obstructed drain can cause personal injury or property damage.</p>
---	--

COOKING GUIDELINES

The steamer steam cooks vegetables, frankfurters, eggs in their shells, and certain other meats or food items at atmospheric pressure.

These cooking guidelines are suggestions only. You should experiment with your food products to determine the cooking times that will give you the best results. Variables which affect cooking time include size, weight, thickness of foods, temperature, density, previous condition of the foods (fresh, pre-blanched or frozen) and degree of doneness desired.

PRODUCT	TIME (Minutes)	WEIGHT PER PAN
COOK IN SOLID PANS		
Eggs, Scrambled	10 - 12	8 Dozen
Rice, Long Grain (Cover with 4 cups water per pound.)	25	2 lb.
Pasta (Place perforated pan inside solid pan, cover pasta with cold water.)		
Spaghetti, Regular/Vermicelli	12 - 15	
Macaroni, Shells/Elbows	15 - 18	
Noodles, ½" wide	12 - 15	
Lasagna Noodles	15 - 18	

INSTALLATION AND OPERATION MANUAL,
ELECTRIC COUNTER CONVECTION STEAMER, MODELS R24-3, R24-5

PRODUCT	TIME (Minutes)	WEIGHT PER PAN
Frozen Casseroles, Lasagna	35	Full Pan
Meat Loaf, 3 - 5 pounds each	40	15 lb.
Beef		
Ground Chuck	20 - 25	10 lb.
Sliced as Purchased	35 - 40	10 lb.
Shrimp, Frozen, 10 per pound	5	4 lb.
Beans		
Baked	9	10 lb. Can
Refried	9	10 lb. Can
Canned Vegetables	6	10 lb. Can
Prunes, Dried	12 to 15	
COOK IN PERFORATED PANS		
SEAFOOD		
Clams		
Frozen	10 - 12	3 Doz.
Fresh, Cherrystone	5 - 6	3 Doz.
King Crab, Frozen		
Claws	4	2-1/2 lb.
Legs	4 - 6	4-1/2 lb.
Lobster Tail, Frozen	6	10 lb.
Lobster, Live, 10 - 12"	5	4 Per Pan
Salmon Fillets, Frozen, 8 ounces each	5	7-1/2 lb.
Scallops, Fresh	4	3 lb.
Scrod Fillets, Fresh	3 - 5	4 lb.
Eggs		
Hard Cooked	15	4 Doz.
Soft Cooked	9 - 10	4 Doz.
Soft Yolk for Caesar Salad	6 - 8	4 Doz.
Chicken - Breasts, Legs, Thighs	20	15 lb.
Turkey, Frozen		
Breasts (2)	90	6 - 7 lb. Each
Cut Lengthwise	55	20 - 25 lb.

INSTALLATION AND OPERATION MANUAL,
ELECTRIC COUNTER CONVECTION STEAMER, MODELS R24-3, R24-5

PRODUCT	TIME (Minutes)	WEIGHT PER PAN
Corned beef	40 - 75	6 - 8 lb.
Hot Dogs or Wieners	3	80 - 100 Count
VEGETABLES		
Asparagus Spears		
Frozen	10 - 12	3 Doz.
Fresh	5	5 lb.
Beans		
Green, 2" cut, Frozen/Fresh	6	5 lb.
Lima, Frozen	8	5 lb.
Baby Lima, Frozen	5	5 lb.
Brussel Sprouts, Frozen	6	5 lb.
Broccoli		
Spears, Frozen	8	4 lb.
Spears, Fresh	6	5 lb.
Florets, Frozen	6	5 lb.
Cabbage, Fresh, 1/6 Cut	8	5 lb.
Carrots		
Baby Whole, Frozen	8	7 lb.
Crinkle Cut, Frozen	7 - 8	4 lb.
Sliced, Fresh	11	9 lb.
Cauliflower, Florets		
Frozen	6	4 lb.
Fresh	7 - 8	5 lb.
Celery, 1" Diagonal Cut	7	5 lb.
Corn		
Yellow Whole Kernel, Frozen	5	5 lb.
Cobbettes, Frozen	8	27 Ears
	16 - 18	80 Ears
Corn-On-Cob, Fresh	10 - 12	18 Ears
	16 - 18	54 Ears
Peas, Green	6	5 lb.
Potatoes, Whole Russet	55	40 lb.

INSTALLATION AND OPERATION MANUAL,
ELECTRIC COUNTER CONVECTION STEAMER, MODELS R24-3, R24-5

PRODUCT	TIME (Minutes)	WEIGHT PER PAN
Spinach Chopped, Frozen	17	6 lb.
Defrosted	5	6 lb.
Fresh Cut	3	2 lb.
Squash, Acorn Halves	25	10 Halves
Zucchini, Slices	8	10 lb.
Frozen Mixed Vegetables	6 - 7	5 lb.
FRUIT		
Fruit, Blanch for Peeling, Grapefruit, Oranges	3	
Pineapple, Whole for Cutting	4	

INSTALLATION AND OPERATION MANUAL,
ELECTRIC COUNTER CONVECTION STEAMER, MODELS R24-3, R24-5

6.0 MAINTENANCE

	WARNING: Disconnect the power supply to the appliance before cleaning or servicing.
---	--

	CAUTION: Live steam and accumulated hot water in the compartment may be released when the door is opened.
---	--

	CAUTION: The appliance and its parts are hot. Use care when operating, cleaning and servicing the appliance.
---	---

COLD WATER CONDENSER

The steamer is equipped with a cold water condenser in the rear of the cooking chamber which helps to condense the steam prior to discharge into the drain. The steamer freely vents itself by the negative pressure created by the condensate water drainage. This negative pressure prevents steam leakage around the door gasket and helps draw the steam through the cooking compartment. Steam leakage at the door may indicate a plugged or improperly installed drain.

REMOVAL OF SCALE DEPOSITS

It is recommended that your steamer be delimed once a month, or more often if necessary.

Should your steamer develop a heavy buildup of lime scale deposits, use CLR.

Before beginning deliming procedures, ensure that water is not overflowing into the cooking compartment.

The generator tank has a removable sealed tank cover. The main purpose of the removable cover is for inspection of the interior of the tank for lime build up and easy removal of large pieces of lime that will not flush out drain. Should the tank cover have to be removed, check condition of sealing gasket before replacing cover. The hold down bolts are to be tightened to 160 inch pound torque each.

	NOTICE: Contact the factory, the factory representative or local service company to perform maintenance and repairs.
---	---

INSTALLATION AND OPERATION MANUAL,
ELECTRIC COUNTER CONVECTION STEAMER, MODELS R24-3, R24-5

REMOVAL OF SCALE DEPOSITS (Continued)



WARNING: Read and follow instructions on the CLR bottle. Use plastic or rubber gloves to avoid skin contact. If CLR comes in contact with skin, rinse with clean water.

1. Drain steam generator by setting the main power switch to OFF. Set cooking time to "0".
2. Set the main power switch to DELIME.
3. Delime port (A) is located on left side at the rear of the unit. Unscrew hex plug from elbow to allow CLR solution to be poured in using a tube and funnel. Pour in 28 ounces of solution into the generator (pour slowly to avoid spillage). Remove tube and funnel.
4. Screw the hex plug back into the elbow so that it is sealed.
5. Turn main power switch to ON.
6. Allow steamer to remain in READY cycle for 1-1/2 hours, then turn main power switch OFF and allow generator to drain.
7. FLUSH CYCLE: Turn main power switch to ON. When READY light comes on, turn main power switch to OFF to flush generator. Repeat this step three times to completely flush generator.
8. Clean exterior and interior. Use a mild solution of soap and water. Rinse with clean cloth. Dry with soft cloth. Leave compartment door open when not in use.

The steamer is now ready for use. Turn off for overnight shutdown.

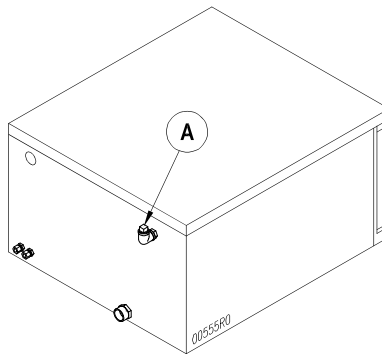

INSTALLATION AND OPERATION MANUAL,
ELECTRIC COUNTER CONVECTION STEAMER, MODELS R24-3, R24-5

7.0 ADJUSTMENT FOR HIGH ALTITUDE LOCATIONS



NOTICE: Contact the factory, the factory representative or local service company to perform maintenance and repairs.

The steamer has been factory set so that when it is ON and in the READY mode, it will maintain water temperature in the steam generator tank at approximately 205 degrees Fahrenheit (just below water boiling point). However, for high altitude locations, an authorized servicer must adjust the steamer temperature lower. To adjust:

1. Remove side panel and turn control panel power switch to ON.
2. Open compartment door, and after about 5 minutes, steam will be seen, entering the cooking compartment.
3. Turn thermostat shaft counterclockwise to lower temperature until steam just ceases to enter cooking compartment and READY light goes on.
4. Replace side panel.
5. Follow TESTING PROCEDURES in this manual.

INSTALLATION AND OPERATION MANUAL,
ELECTRIC COUNTER CONVECTION STEAMER, MODELS R24-3, R24-5

8.0 TROUBLESHOOTING

WATER FLOWS INTO DRAIN DURING SHUTDOWN

When steamer is shut down and cold water is running continuously into the open drain, either or both solenoid valves did not close when steamer was turned off.

1. Disassemble solenoid valve(s) and examine for scale or foreign particles lodged in diaphragm or core tube.
2. Clean valve(s) thoroughly and reassemble, or replace valve(s).

WATER OVERFLOWS INTO COOKING COMPARTMENT

When steamer is first turned on for the day, and the following conditions occur:

- READY light does not come on after about 5 minutes,
- Water begins to overflow into cooking compartment,
- Water fill solenoid valve is open,

Any or all of these symptoms may indicate a problem with the operating probe due to either:

1. A short between the operating probe terminal and body of the steamer. Call your authorized servicer.
2. Excessive scale build-up on the operating probe. This acts as an "insulation" and prevents the probe from sensing the water level. It is therefore unable to close the water fill (solenoid) valve to shut off the water.

As a temporary solution, with power OFF, unscrew probes, check visually, and clean or chip off scalant. Replace probe.

This problem is an indication of severe harmful water conditions which should be corrected immediately to avoid damage to the components and ultimate malfunction of the steamer. (See WATER QUALITY in this manual).

INSTALLATION AND OPERATION MANUAL,
ELECTRIC COUNTER CONVECTION STEAMER, MODELS R24-3, R24-5

8.0 TROUBLESHOOTING (Continued)

HEATER ELEMENTS DO NOT COME ON

When the steamer is turned ON and heater elements do not activate, and the READY light does not come on, then the contactors may be burned out. If a considerable amount of “chattering” of contactors has been previously experienced, then the thermostat bulb may be coated with scalant and unable to sense water temperature in the boiler accurately, and therefore unable to control the contactors.

1. Replace contactors.
2. Unscrew thermostat bulb, clean off scalants and screw thermostat bulb back in.

This problem may be an indication of inadequate water quality and is not covered under warranty. Have water quality analyzed and corrected immediately to avoid complete malfunction of the steamer.

UNIT SHUTS DOWN WHILE IN OPERATION

Pressure switch has been activated due to 5 psi (34 kPa) pressure in the generator tank. Pressure in the generator tank is caused by plugged steam jet tubes or steam diverters due to scale or poor water conditions. Steam jet tubes/steam diverter will have to be cleaned or replaced.