



IMPORTANT FOR FUTURE REFERENCE
 Please complete this information and retain this manual for the life of the equipment:

Model #: _____
 Serial #: _____
 Date Purchased: _____

Owner's Manual

G-Series, SL-Series & B-Series GAS CONVECTION OVENS



Model GS-15SC



Model GS-25SC

⚠ WARNING

Improper installation, adjustment, alteration, service or maintenance can cause property damage, injury or death. Read the installation, operating and maintenance instructions thoroughly before installing or servicing this equipment.



1100 Old Honeycutt Road Fuquay-Varina, North Carolina 27526 USA
www.southbendnc.com





SAFETY PRECAUTIONS

Before installing and operating this equipment, be sure everyone involved in its operation is fully trained and aware of precautions. Accidents and problems can be caused by failure to follow fundamental rules and precautions.

The following symbols, found throughout this manual, alert you to potentially dangerous conditions to the operator, service personnel, or to the equipment.

DANGER  This symbol warns of immediate hazards that will result in severe injury or death.

WARNING  This symbol refers to a potential hazard or unsafe practice that could result in injury or death.

CAUTION  This symbol refers to a potential hazard or unsafe practice that could result in injury, product damage, or property damage.

NOTICE This symbol refers to information that needs special attention or must be fully understood, even though not dangerous.

WARNING  **FIRE HAZARD**
FOR YOUR SAFETY

Do not store or use gasoline or other flammable vapors and liquids in the vicinity of this or any other appliance. Keep area around cooking appliances free and clear of combustibles. Purchaser of equipment must post in a prominent location detailed instructions to be followed in the event the operator smells gas. Obtain the instructions from the local gas supplier.

WARNING  Asphyxiation can result from improper ventilation. Do not obstruct the flow of combustion and ventilation air to and from your cooking equipment.

NOTICE Be sure this Operator's Manual and important papers are given to the proper authority to retain for future reference.

NOTICE This product is intended for commercial use only. NOT FOR HOUSEHOLD USE.



Congratulations! You have purchased one of the finest pieces of heavy-duty commercial cooking equipment on the market.

You will find that your new equipment, like all Southbend equipment, has been designed and manufactured to meet the toughest standards in the industry. Each piece of Southbend equipment is carefully engineered and designs are verified through laboratory tests and field installations. With proper care and field maintenance, you will experience years of reliable, trouble-free operation. **For best results, read this manual carefully.**

RETAIN THIS MANUAL FOR FUTURE REFERENCE.

Table of Contents

Specifications	4
Installation	7
Operation	20
Operation for Touchscreen Models Only	28
Cooking Hints.....	38
Cleaning	41
Adjustments	43
Troubleshooting	46

Read these instructions carefully before attempting installation. Installation and initial startup should be performed by a qualified installer. Unless the installation instructions for this product are followed by a qualified service technician (a person experienced in and knowledgeable with the installation of commercial gas an/or electric cooking equipment) then the terms and conditions on the Manufacturer’s Limited Warranty will be rendered void and no warranty of any kind shall apply.

In the event you have questions concerning the installation, use, care, or service of the product, write to:

Southbend
1100 Old Honeycutt Road
Fuquay-Varina, North Carolina 27526 USA

The serial plate is located on the interior side of the lower front panel, as shown below.

Figure 1

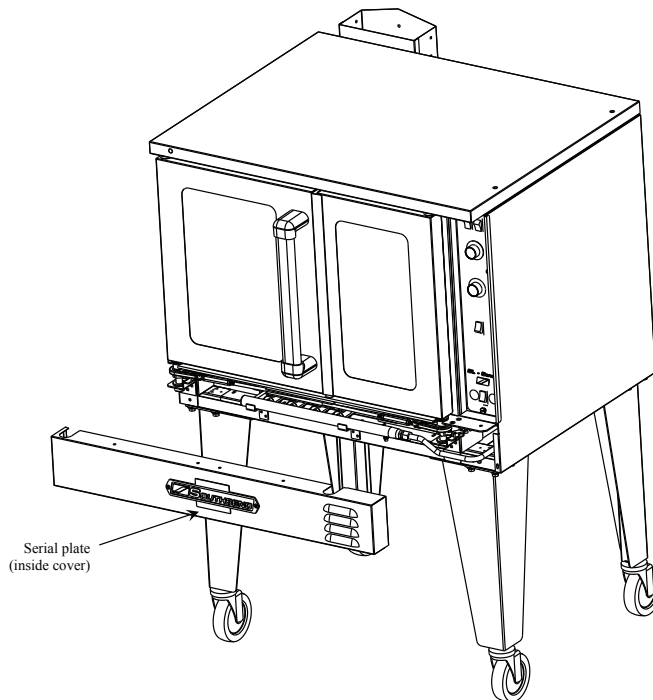



The serial plate is located inside the lower front panel. It indicates the type of gas the unit is equipped to burn. All Southbend equipment is adjusted at the factory. Check type of gas on serial plate. These models are design-certified for operation on natural or propane gases. For natural gas, the regulator is set to deliver a 4.0" W.C. pressure to the manifold. For propane gas, it is set to deliver 11" W.C.

GAS SUPPLY

Adequate clearance must be provided in the aisle to allow the doors to open sufficiently to permit the removal of the racks and for serviceability. Although no clearance is required behind the motor on the rear of the oven, care must be taken to provide adequate air circulation to prevent the motor from overheating. Do not locate the oven adjacent to any high heat or grease-producing piece of equipment, such as a range top, griddle, fryer, etc., that could allow radiant heat to raise the exterior temperature of the oven above 130°F (54°C). DO NOT MOUNT ABOVE OTHER COOKING EQUIPMENT.

Minimum Clearance from	Back	Right Side	Left Side	Floor
Minimum Clearance from Combustible Construction	0"	0"	2"	0"
Minimum Clearance from Non-Combustible Construction	0"	0"	0"	0"
Minimum Clearance from heat producing appliance	6"	6"	6"	6"

There must be adequate clearance between the left side of the ovens and combustible construction.



WARNING

MINIMUM CLEARANCES

Local codes regarding installation vary greatly from one area to another. The National Fire Protection Association, Inc. states in its NFPA 96 latest edition that local codes are the "authority having jurisdiction" when it comes to installation requirements for equipment. Therefore, installations should comply with all local codes. Southbend reserves the right to change specifications and product design without notice. Such revisions do not entitle the buyer to corresponding changes, additions, or replacements for previously purchased equipment. This product is intended for commercial use only, not for household use. The installation must conform with local codes, or in the absence of local codes, with the *National Fuel Gas Code, ANSI Z223.1, Natural Gas Installation Code, CAN/CGA-B149.1*, or the *Propane Installation Code CAN/CGA-B149.2*, as applicable, including:

1. The appliance and its individual shutoff valve must be disconnected from the gas supply piping system during any pressure testing of that system at test pressures in excess of 1/2 psi (3.45 kPa).
2. The appliance must be isolated from the gas supply piping system by closing its individual manual shutoff valve during any pressure testing of the gas supply piping system at test pressures equal to or less than 1/2 psi (3.45 kPa).

NOTICE

SPECIFICATIONS

If applicable, the vent line from the gas appliance pressure regulator shall be installed to the outdoors in accordance with local codes, or in the absence of local codes, with the *National Fuel Gas Code, ANSI Z223.1, Natural Gas Installation Code, CAN/CGA-B149.1*, or the *Propane Installation Code CAN/CGA-B149.2, as applicable*.

This appliance should be connected ONLY to the type of gas for which it is equipped.

A 3/4" NPT line is provided at the rear for the gas connection. An adequate gas supply is imperative. Undersized or low pressure lines will restrict the volume of gas required for satisfactory performance. Fluctuations of more than 25% on natural gas or 10% on propane gas will create problems and affect burner operating characteristics.

An adequate gas supply line to the unit should be no smaller than the inside diameter of the pipe from the unit to which it is connected.

Purge the supply line to clean out dust, dirt, or other foreign matter before connecting the line to the unit.

All pipe joints and connections must be tested thoroughly for gas leaks. Use only soapy water for testing on all gases. NEVER use an open flame to check for gas leaks. All connections must be checked for leaks after the unit has been put into operation. Test pressure should not exceed 14" W.C.

Model Number	# of Ovens	Total BTU	Type of Gas	Orifice Size
BGS/12...	Single-Deck	54,000	Propane	56
			Natural Gas	47
BGS/22...	Double-Deck	108,000	Propane	56
			Natural Gas	47
BGS/13...	Single-Deck	40,000	Propane	56
			Natural Gas	47
BGS/23...	Double-Deck	80,000	Propane	56
			Natural Gas	47
SLGS/12... SLGB/12...	Single-Deck	72,000	Propane	56
			Natural Gas	47
SLGS/22... SLGB/22...	Double-Deck	144,000	Propane	56
			Natural Gas	47
GS/15... GB/15...	Single-Deck	90,000	Propane	56
			Natural Gas	47
GS/25... GB/25...	Double-Deck	180,000	Propane	56
			Natural Gas	47



If a ventilation canopy is used, it is recommended that a canopy extend 6" past the appliance and that the bottom edge be located 6" from the floor. Filters should be installed at an angle of 45° or more from the horizontal. This position prevents dripping grease and facilitates collecting the run-off grease in a drip pan, unusually installed with a filter.

If an exhaust fan is used, it should be installed at least 2" above the flue opening at the top of the unit. A strong exhaust fan tends to create a vacuum in the room and may interfere with burner performance. Fresh air openings approximately equal to the fan area will relieve such a vacuum. In case of unsatisfactory performance on any appliance, check the appliance with the exhaust fan in the "OFF" position. Do this only long enough to check equipment performance. Then turn the exhaust fan back on and let it run to remove any exhaust that may have accumulated during the test.

If the oven flue is connected directly to an outside flue, a CSA International design certified down draft diverter must be installed at the flue outlet of the oven and connected to the outside flue.

NOTICE

Proper ventilation is the owner's responsibility. Any problem due to improper ventilation will not be covered by the warranty.

WARNING

Improper ventilation can result in personal injury or death. Ventilation which fails to properly remove flue products can cause headaches, drowsiness, nausea, or could result in death.

All units must be installed in such a manner that the flow of combustion and ventilation air are not obstructed. Provisions for adequate air supply must be provided. Do not obstruct the front or rear of the unit as combustion air enters through these areas.

Be sure to inspect and clean the ventilation system according to the ventilation equipment manufacturer's instructions.

VENTILATION

Ovens ordered with the 120V power option are equipped with one or two power cords with a standard 120V single-phase plug with a ground prong. Single-deck ovens will have one power cord; double-deck ovens will have two.

Ovens with other power options have a terminal block on the rear of the oven that must be wired to the power supply. Depending on how the power supply is connected to the terminal block, the oven can operate on either single-phase or three-phase power.

Power Option	Power Type	# of Ovens	Maximum Amps
120/60/1	120 Volts, 60 Hz, Single Phase	Single-Deck	7.9
		Double-Deck	15.8
208/60/1or3	190-219 Volts, 60 Hz, Single or Three Phase	Single-Deck	4.3
		Double-Deck	8.6
240/60/1or3	220-240 Volts, 60 Hz, Single or Three Phase	Single-Deck	3.8
		Double-Deck	7.5
240/50/1or3	208-240 Volts, 50 Hz, Single or Three Phase	Single-Deck	6.0
		Double-Deck	12.0

Convection ovens require connection to a supply of electricity. The appliance, when installed, must be electrically grounded in accordance with local codes, or in the absence of local codes, with the *National Electrical Code*, *ANSI/NFPA 70*, or the *Canadian Electrical Code*, *CSA C22.2*, as applicable. An electrical diagram is located on the side of the control panel assembly (see drawing on page 37). Electrical diagrams can also be found in this manual beginning on page 37.

ELECTRICAL SUPPLY

INSTALLATION

NOTICE

These installation procedures must be followed by qualified personnel or warranty will be void.

Local codes regarding installation vary greatly from one area to another. The National Fire Protection Association, Inc. states in its NFPA 96 latest edition that local codes are the “authority having jurisdiction” when it comes to installation requirements for equipment. Therefore, installations should comply with all local codes.

The installation must conform with local codes, or in the absence of local codes, with the *National Fuel Gas Code, ANSI Z223.1, Natural Gas Installation Code, CAN/CGA-B149.1*, or the *Propane Installation Code CAN/CGA-B149.2*, as applicable, including:

1. The appliance and its individual shutoff valve must be disconnected from the gas supply piping system during any pressure testing of that system at test pressures in excess of 1/2 psi (3.45 kPa).
2. The appliance must be isolated from the gas supply piping system by closing its individual manual shutoff valve during any pressure testing of the gas supply piping system at test pressures equal to or less than 1/2 psi (3.45 kPa).

STEP 1: UNPACKING

IMMEDIATELY INSPECT FOR SHIPPING DAMAGE

All containers should be examined for damage before and during unloading. The freight carrier has assumed responsibility for its safe transit and delivery. If damaged equipment is received, either apparent or concealed, a claim must be made with the delivering carrier.

Apparent damage or loss must be noted on the freight bill at the time of delivery. The freight bill must then be signed by the carrier representative (Driver). If the bill is not signed, the carrier may refuse the claim. The carrier can supply the necessary forms.

A request for inspection must be made to the carrier within 15 days if there is concealed damage or loss that is not apparent until after the equipment is uncrated. The carrier should arrange an inspection. Be certain to hold all contents plus all packing material.

1. Cut banding straps and remove packing material.
2. Cut banding strap holding oven to wooden skid.
3. If you are installing a single-deck oven, go to Step 2a.
If you are installing a double-deck oven, go to Step 2b.

STEP 2A: INSTALLATION OF LEGS ON SINGLE-DECK-OVENS

1. Raise oven sufficiently to allow clearance for the legs to be attached. Use of a lift truck or other mechanical lifting means is recommended. For safety, "shore up" and support the oven with an adequate blocking arrangement strong enough to support the load. (If it is absolutely necessary to rest the oven on its side, rest it on its left side or back side. Take care to protect the finish on the left side, and to prevent the weight from resting on the motor on the back.)
2. Attach the legs to the bottom corners of the oven using the provided machine screws, flat washers, and lock washers. Each leg is secured by five screws. The mounting holes are pre-drilled and threaded.
3. Screw into the bottom of each leg either an adjustable foot or a caster (depending on which option was ordered). If attaching casters, the two casters with brakes should be attached to the front legs.
4. Lower the oven gently onto a level surface. Never drop or allow the oven to fall.
5. Use a level to make sure that the oven is level. The adjustable feet can be screwed in or out to lower or raise each corner of the oven.
6. If casters were installed, go to Installation Step 3, otherwise go to Step 4

Figure 2

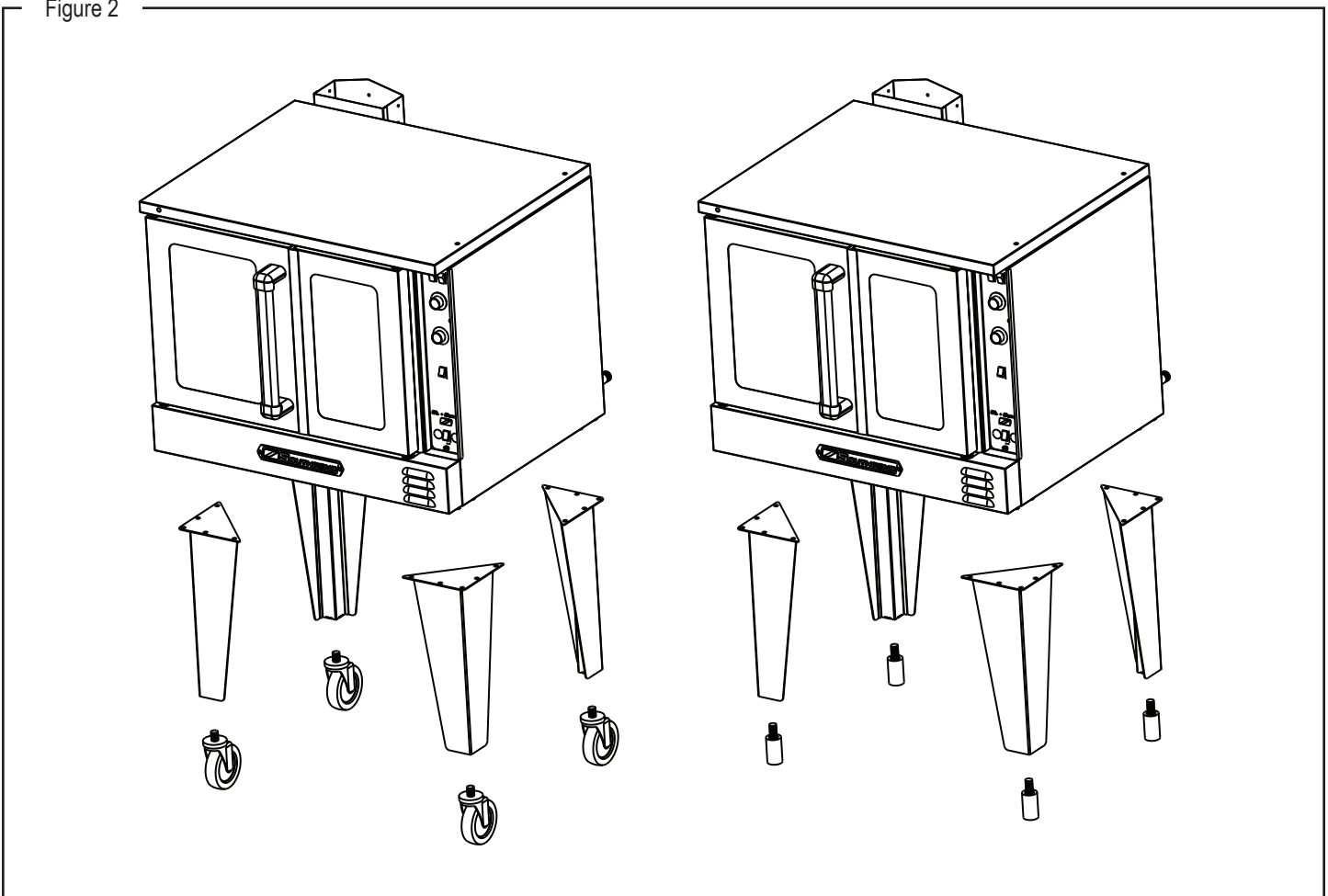

STEP 2B: INSTALLATION OF LEGS ON DOUBLE-DECK-OVENS

Double-deck oven can be shipped either already bolted together, or as two separate ovens to be bolted together after delivery. In either case, the oven that is (or will be) the lower oven will have leg pads already bolted to the bottom corners of the oven. Do the following:

1. Raise oven sufficiently to allow clearance for the legs to be attached. Use of a lift truck or other mechanical lifting means is recommended. For safety, “shore up” and support the oven with an adequate blocking arrangement strong enough to support the load. (If it is absolutely necessary to rest the oven on its side, rest it on its left side or back side. Take care to protect the finish on the left side, and to prevent the weight from resting on the motor on the back.)
2. Screw into the center of each leg pad either an adjustable leg or a caster (depending on which option was ordered). If attaching casters, the two casters with brakes should be attached to the front leg pads.
3. Lower the oven gently onto a level surface. Never drop or allow the oven to fall.
4. Use a level to make sure that the oven is level. The adjustable legs can be screwed in or out to lower or raise each corner of the oven.
5. If casters were installed, go to Installation Step 3, otherwise go to Step 4.

Figure 3

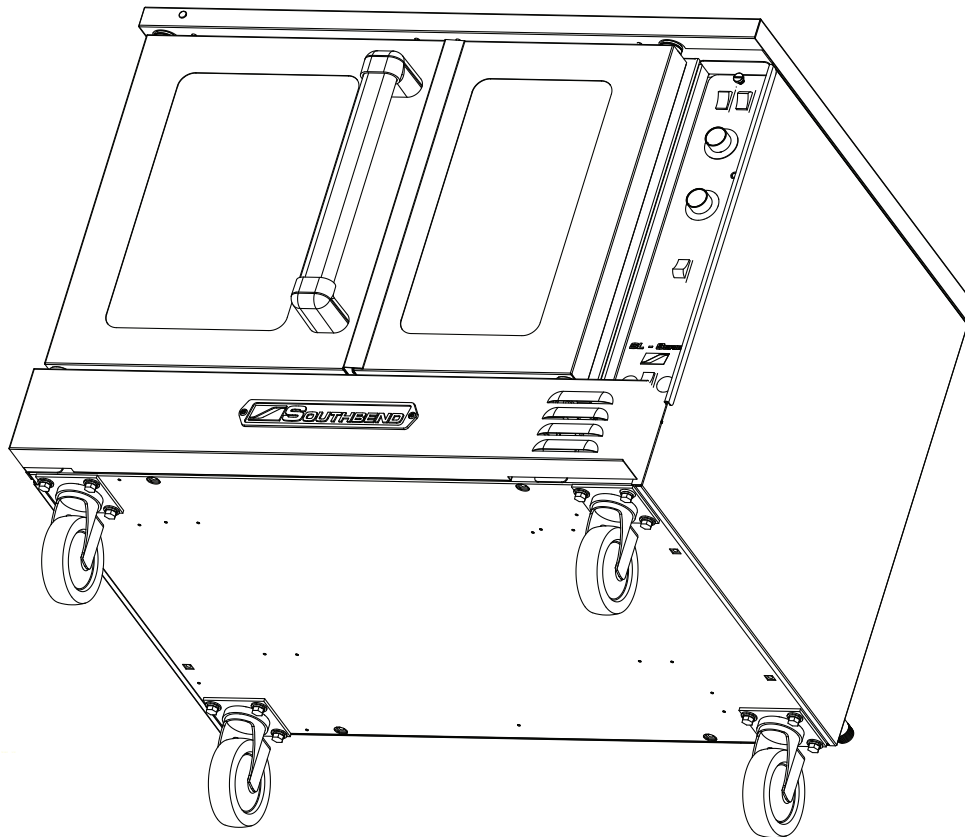

STEP 3: INSTALLATION OF RESTRAINT (ONLY FOR OVENS WITH CASTERS)

NOTICE

For an appliance equipped with casters, (1) the installation shall be made with a connector that complies with the *Standard for Connectors for Movable Gas Appliances, ANSI Z21.69* or *Connectors for Moveable Gas Appliances, CAN/CGA-6.16*, and a quick-disconnect device that complies with the *Standard for Quick-Disconnect Devices for Use With Gas Fuel, ANSI Z21.41*, or *Quick Disconnect Devices for Use with Gas Fuel, CAN1-6.9*, (2) adequate means must be provided to limit the movement of the appliance without depending on the connector and the quick-disconnect device or its associated piping to limit the appliance movement and (3) the restraining means should be attached to a frame member on the back of the unit.

WARNING

To avoid accidental gas disconnection and potential explosion:

If disconnection of this restraint is necessary to move the appliance for cleaning, etc., reconnect it when the appliance is moved to its originally installed position.

1. Secure the restraining-device bracket (item "B" in the following illustration) to a wall stud located as close as possible to the appliance connector inlet and outlet connections. Use four #12 screws (items "C") and plastic anchors (items "A") if necessary.

Figure 4

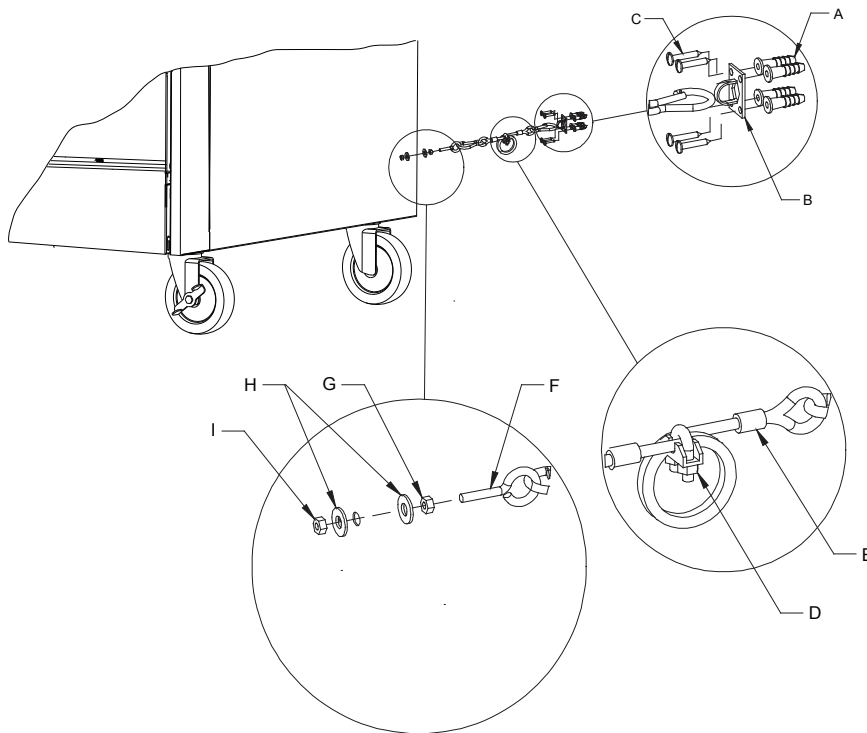

Note: Kit can be purchased from Southbend

2. Install eye-bolt (item “F”) to a frame member on the rear of the equipment. After checking carefully behind the frame member for adequate clearance, drill a 1/4” hole through the frame member.
3. Thread hex nut (item “G”) and slide the washer (item “H”) onto the eye-bolt. Insert the eye-bolt through the 1/4” drilled hole and secure with a washer (item “H”) and nylon lock nut (item “I”).
4. Using the spring-loaded snap hooks, attach the restraining device to the bracket and the eye-bolt.
5. Using the cable clamp (item “D”), adjust the restraining device extended length to prevent over-bending or kinking of the appliance connector.

For units not equipped with flame safety devices, be sure all valves are turned off prior to disconnecting. After reconnecting, be sure that the oven is switched OFF.

STEP 4: STACK DOUBLE-DECK OVEN (F NECESSARY)

Double-deck ovens can be shipped already assembled, but can instead be shipped as two single-deck ovens to be stacked in the field. Also, ovens that were originally ordered as single ovens can be stacked in the field (additional parts are required). This installation step describes the procedure for stacking two single-deck ovens to form a double-deck oven.

1. Uncrate the two ovens. Identify the oven that will be the lower oven (it will be the oven with leg pads attached to the bottom corners). Attach the legs (or casters) to the lower oven as described in Step 2c.
2. If the oven that will be the top oven was NOT ordered as part of a double-deck oven, remove the four leg pads from the bottom of the top oven.
3. Locate and remove the four screws that secure the lower front panel (items “A” in the drawing below). Lift up the panel and pull it forward to remove it, then set it aside.
4. Locate and remove the six screws that secure the right side panel to the oven (items “B” in the drawing below). Remove the right side panel and insulation and set them aside.

Figure 5

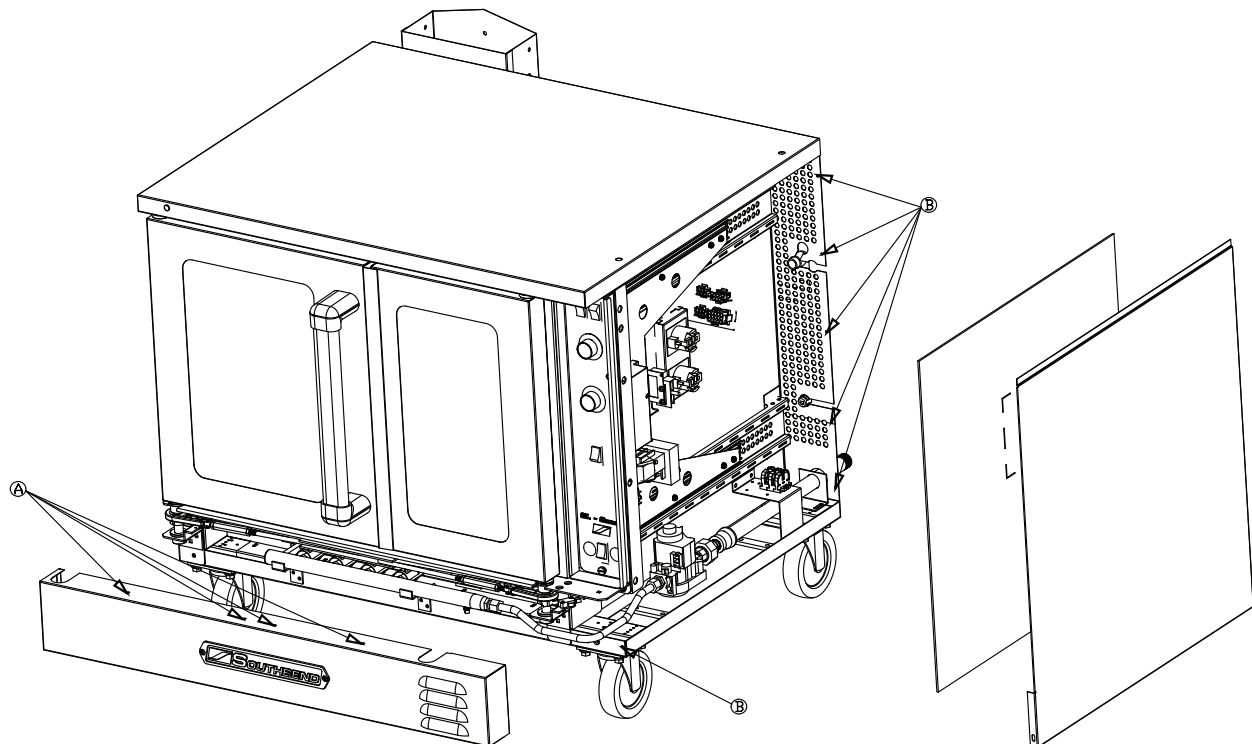

- Lift the top oven and position it on top of the lower oven, as shown in the drawing below.

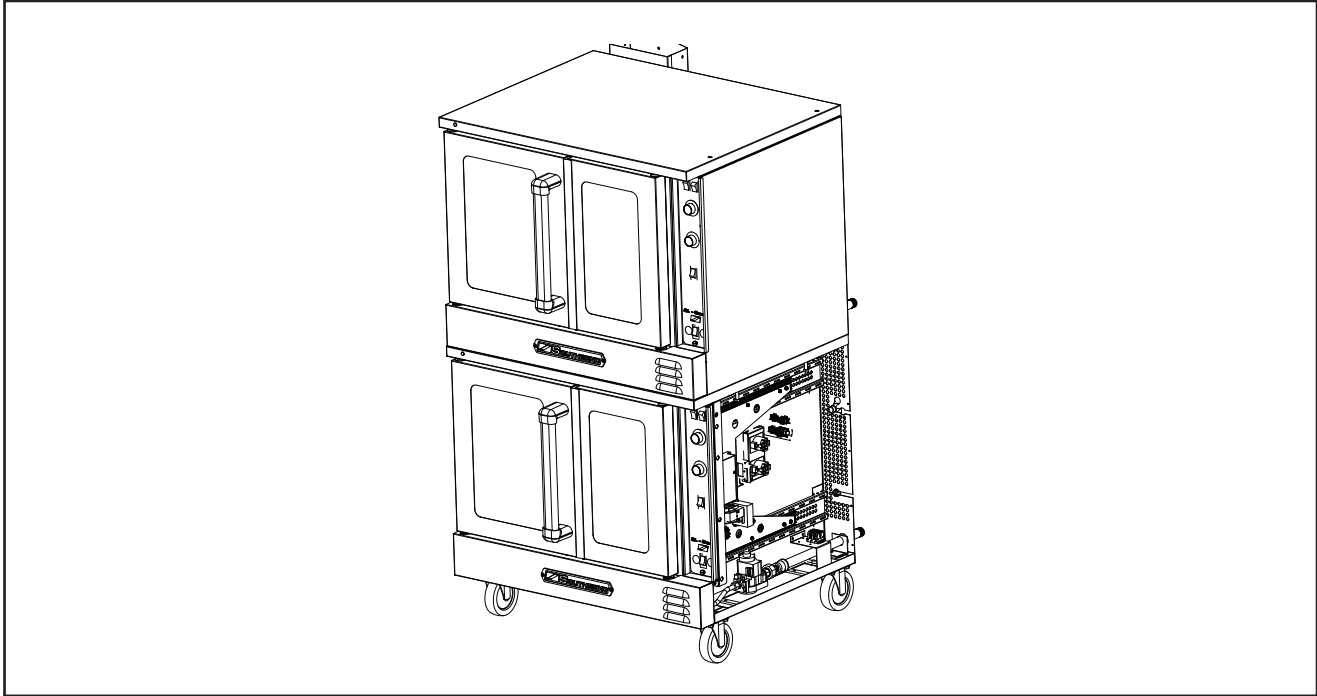

- Move to the rear of the ovens and remove the six screws shown as items "A" in the left-hand drawing below. Position the tie bracket (item "B") as shown in the right-hand drawing below. Re-insert the screws that you just removed through the holes in the tie bracket, but do not tighten them yet.

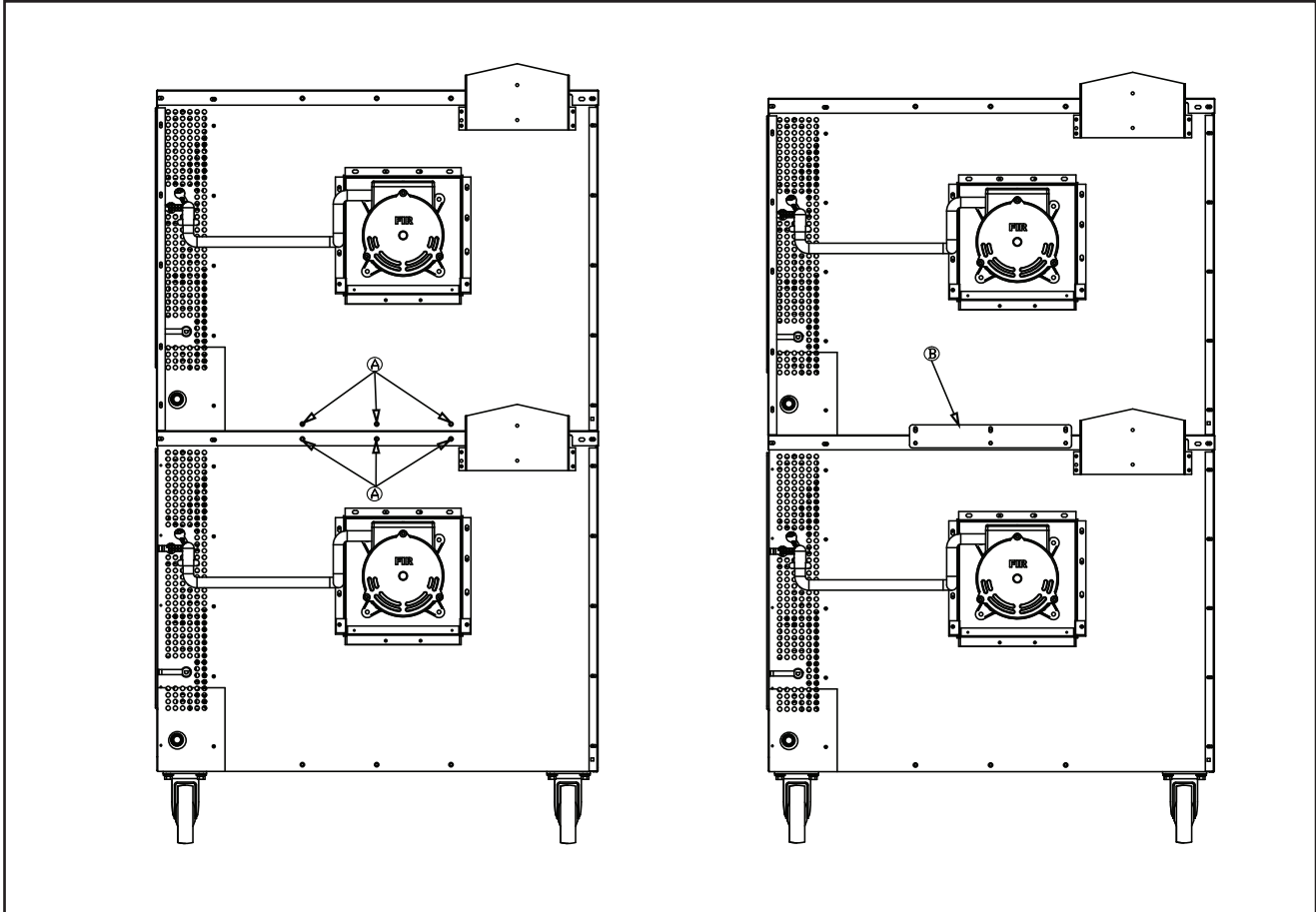

7. Insert two bolts (items "A" in the following diagram) up through the top of the lower oven and screw them into the threaded holes in the bottom of the top oven. Tighten these bolts and the screws that you did not tighten in the previous step.

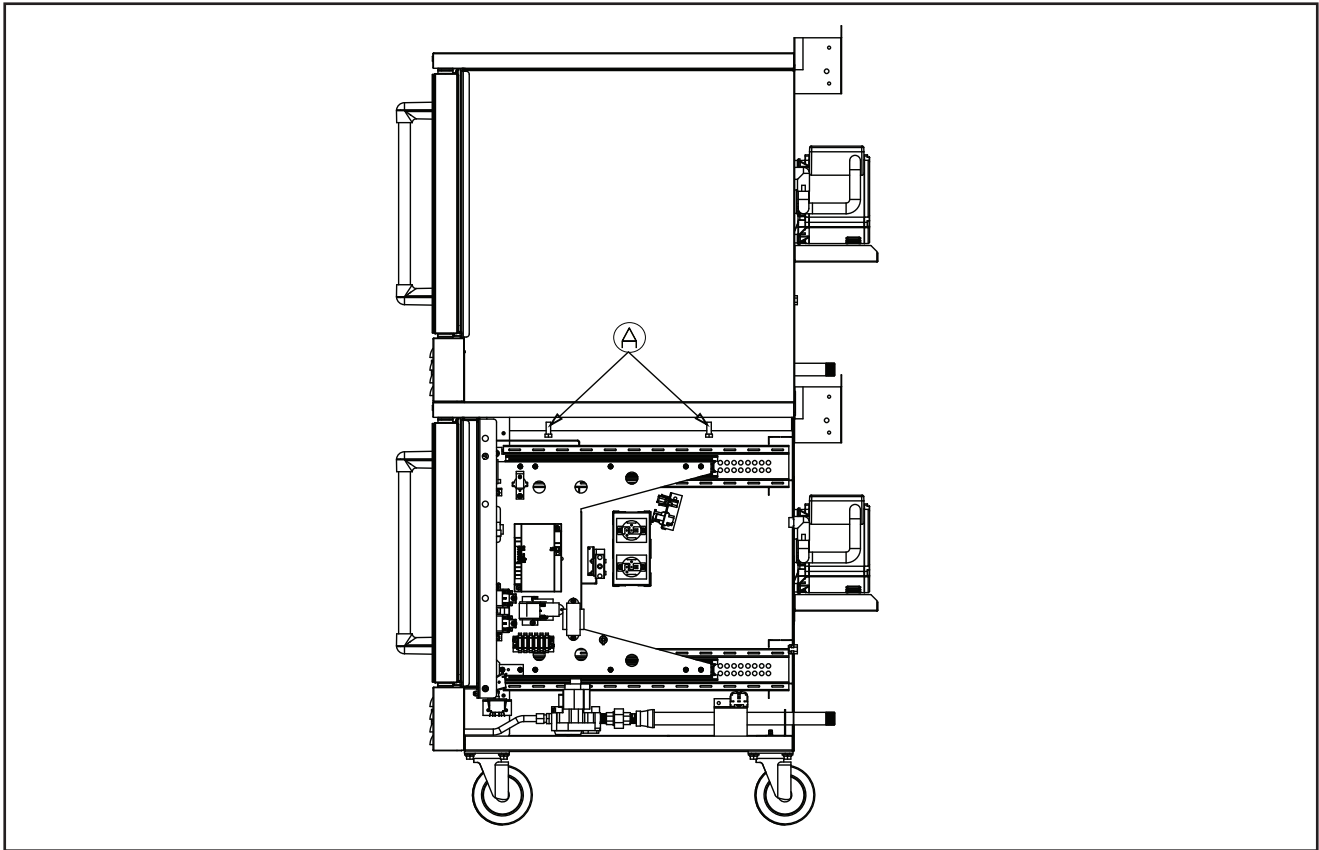

8. Assemble the gas piping shown in the following drawing. Be sure to check all connections for leaks once the oven has been installed.

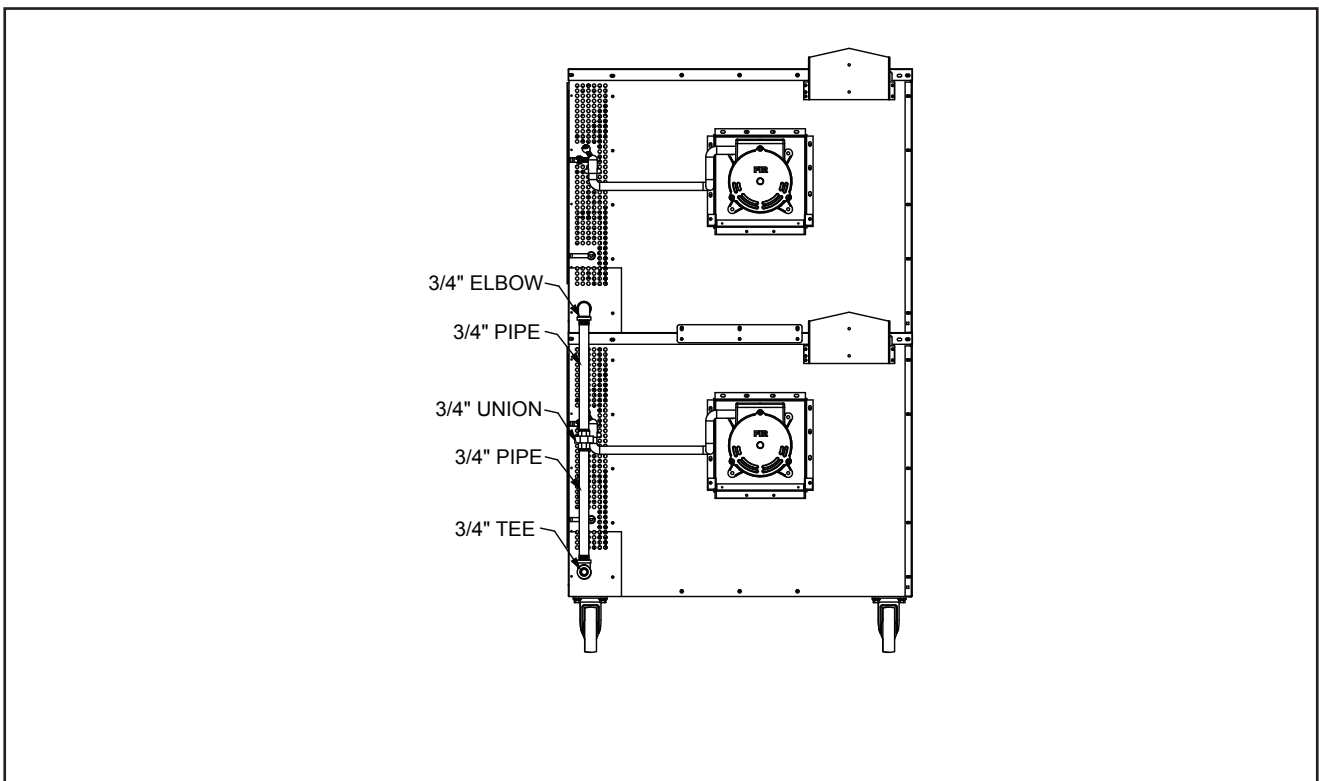

9. Install the flue stack as shown in the following diagram:

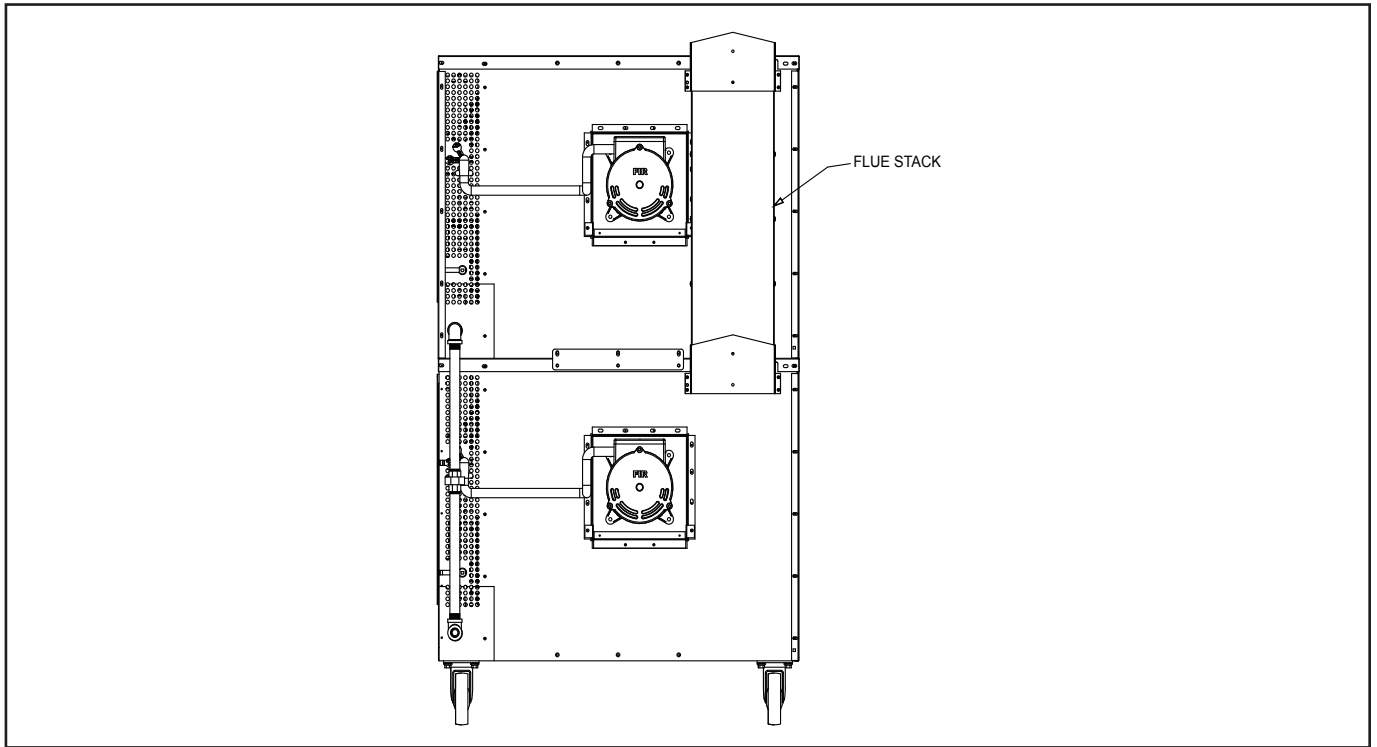

10. Replace the right side insulation, exterior panel, and lower front panel that you removed in step 4 of this procedure.

STEP 5: INSTALL DOWN DRAFT DIVERTER (IF APPLICABLE)**NOTICE**

Installation must use approved CSA International down draft diverter supplied by Southbend.

If the oven flue is to be connected directly to an external vent, a down draft diverter must be installed. The installation of ventilation pipes through walls and roofs must conform to all local codes. To install the down draft diverter, do the following:

1. Slip the down draft diverter over the top of the flue located at the top left rear corner of the oven (see drawing below). Allow the diverter to slide down as far as it will go.
2. Using a 9/64" or 5/32" drill bit, drill eight holes through the flue box using the pre-drilled holes in the diverter as a guide.
3. Secure the diverter to the flue box using the #10 x 1/2 sheet metal screws shipped with the diverter.

Figure 6

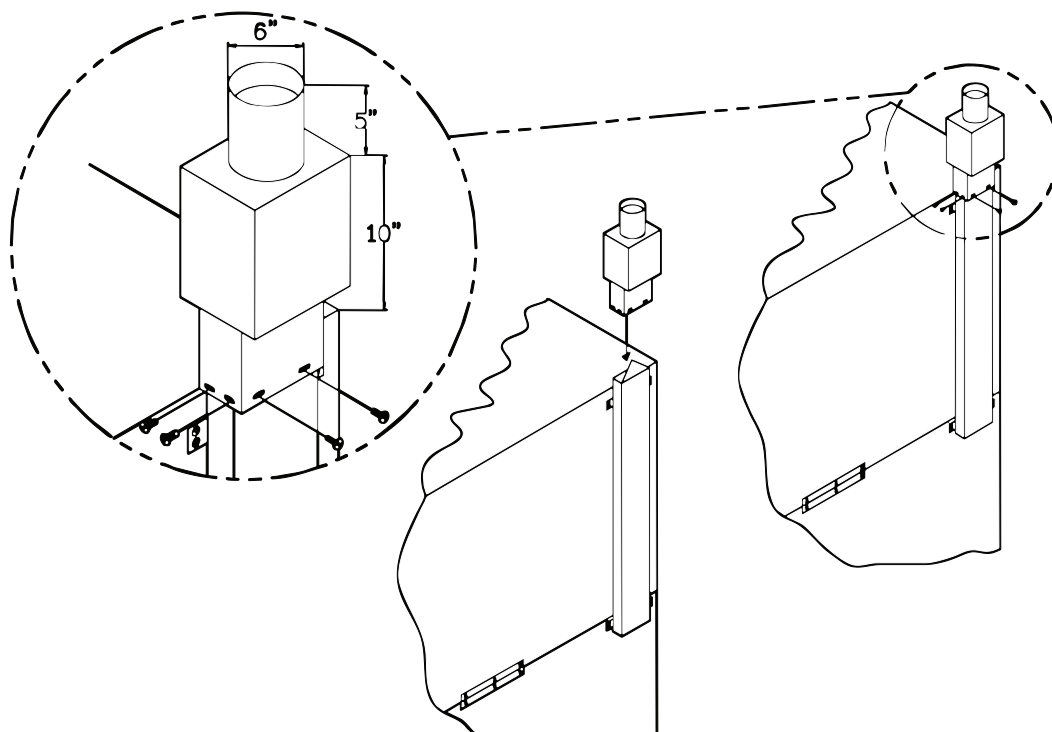
Installation of Down Draft Diverter

STEP 6: INSTALLATION OF OPEN PAN STORAGE ON G & SL SERIES OVENS (OPTIONAL)

The following describes how to assemble the optional open pan storage for G-Series and SL-Series ovens. All holes are pre-drilled for the provided screws.

1. Attach the legs to the oven as described in installation Step 2a.
2. Attach the two frame hangers (items "A" in the following drawing). The flanged side of each hanger must be on the side of the hanger closest to the edge of the oven.

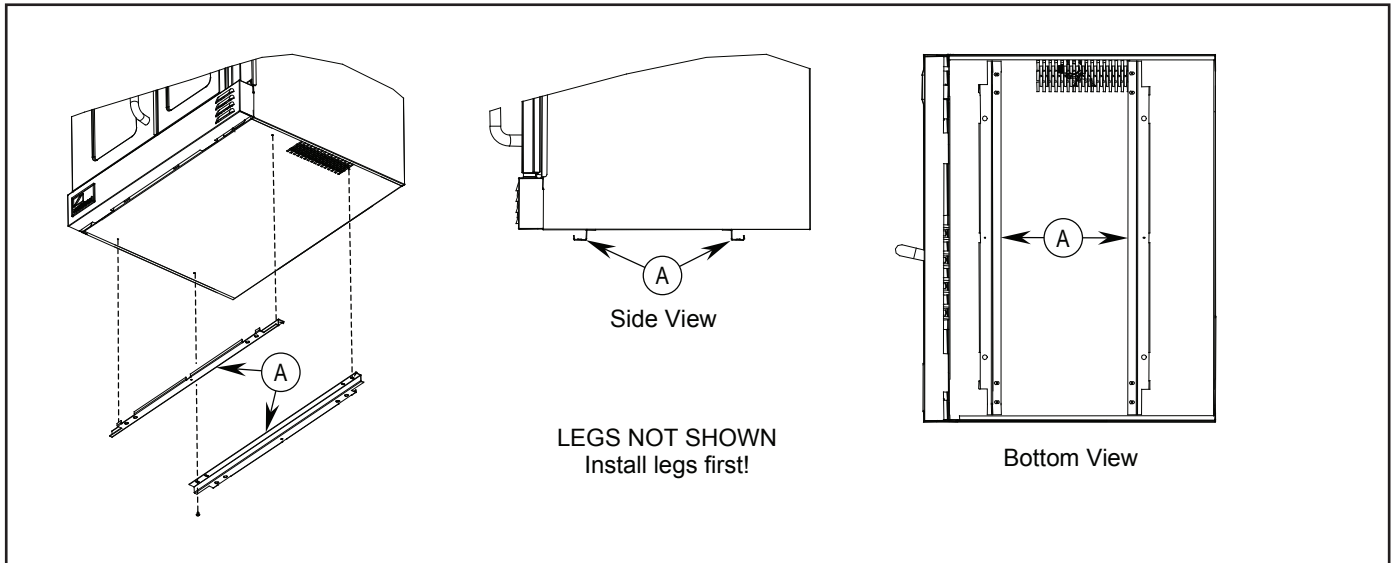

3. Attach the pan-stop to the shelf by first inserting the tab on the bottom of the pan-stop through the slot near the rear of the shelf, then tilting the pan-stop up to a vertical position (as shown in the following drawing). Secure the pan-stop with a screw that passes through a hole in the shelf and into a threaded hole on the tab of the pan-stop (do not fully tighten this screw yet). Position the shelf below the oven (for ovens with casters, rest the shelf on the top of the caster flanges, as shown below).

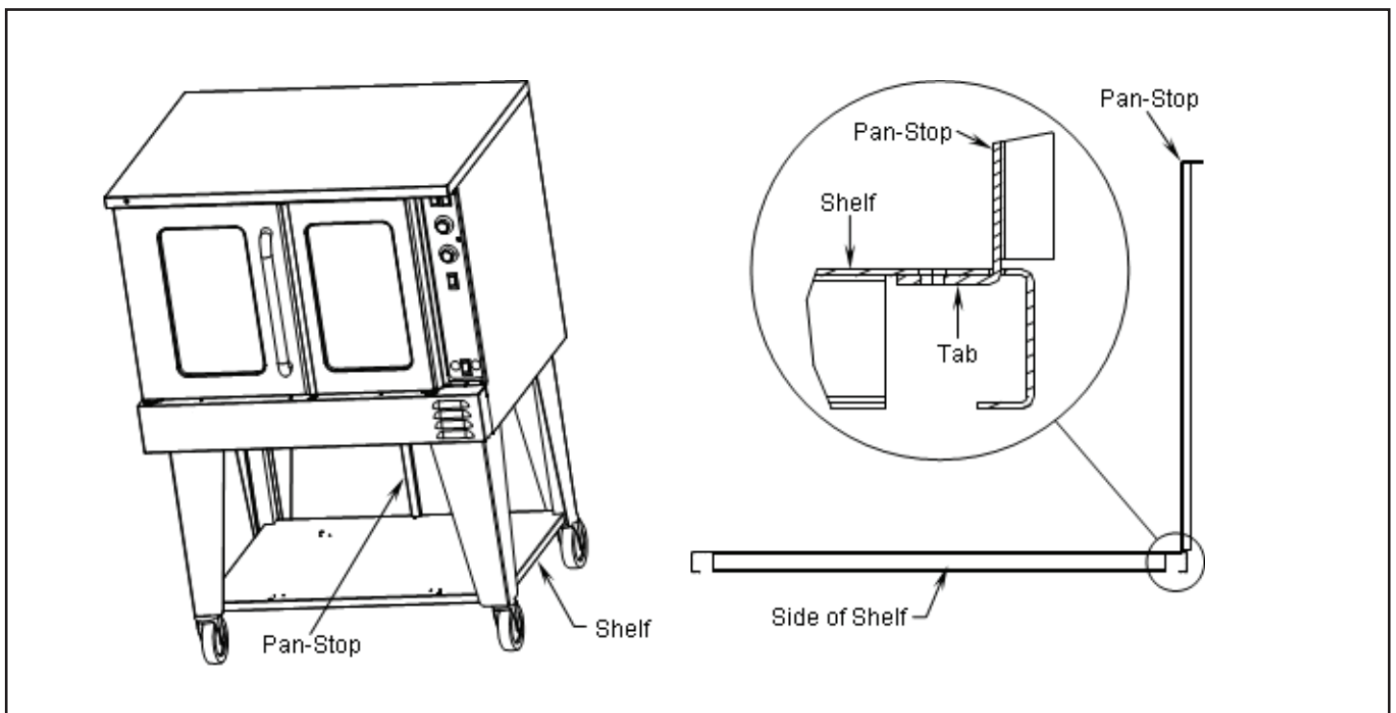

4. Hang the two pan guides from the frame hangers. The guides cannot be inserted from the side of the oven because the legs are in the way. Instead, begin by holding the guide parallel to the side of the oven with the horizontal bars of the guide extending inward (so that the pans can rest on them). Insert the guide from in front of the oven. Slip the top-front hook of the guide through the opening on the front of the front frame hanger near the final-position hole, then slip the top-rear hook of the guide around the end of the flange of the rear frame hanger. Finally, slide the guide toward the center of the oven until the hooks drop through the final-position holes in the frame hangers.

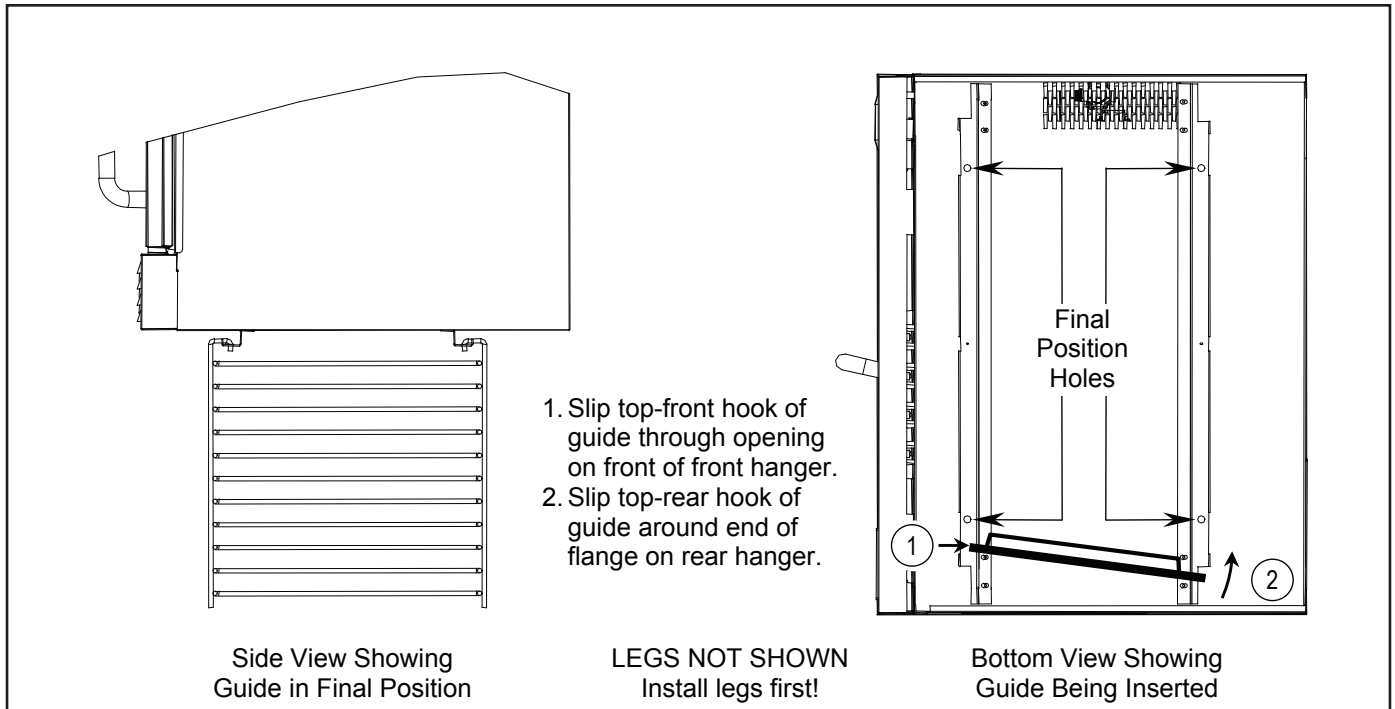

5. Lift the shelf upwards until it is in contact with the lowest horizontal bar of the guides (the bottom ends of the guides should extend into matching holes on the shelf). Attach the shelf to the guides using four clips, each of which is attached to the shelf with two screws.

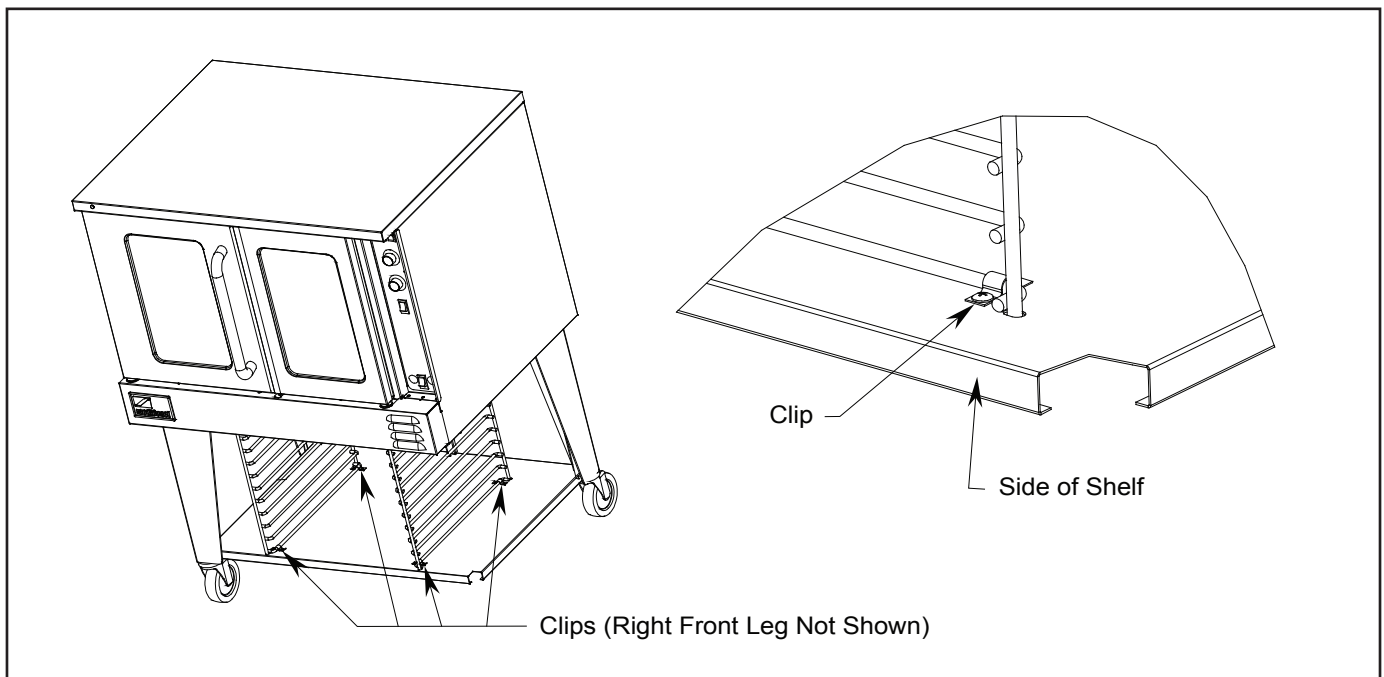

6. Secure the top of the pan-stop to the bottom of the oven with a screw, and tighten the screw holding the pan-stop to the shelf.



Wiring diagrams are located on the side of the control panel assembly, as well as in this manual (beginning on Figure 10). Be sure that the input voltage and phase match the requirements shown on the serial plate, which is located inside the lower front panel.

Ovens ordered to operate on **120V** power have a three-wire cord. (Double-deck ovens have two power cords, one for each oven.) Each cord has a three-prong plug that fits any standard three-prong grounded receptacle. Single-oven units require a 15 ampere supply, while double-oven units require a 20 ampere supply. (120V ovens shipped to Canada do NOT have factory installed power cords, and must be wired as described below.)

Ovens without a power cord have a terminal block. The electric supply must be brought through the service panel in the rear of the oven and connected to the terminal block. See the wiring diagrams in this manual (beginning Figure 10). The unit must be adequately grounded. Use 167°F (75°C) wire for all supply lines.

Ovens are factory-equipped with a two-pole terminal block, located behind a cover plate located on the rear of the oven. To connect the supply wires, remove the cover plate, then route the supply wires and the grounding wire through the strain relief fitting to the terminal block. Insert the supply wires, one each, into the two poles of the terminal block and tighten the screws. Insert the ground wire into the grounding lug and tighten the screw. Re-attach the cover plate.

Three phase units are wired as above, using only two supply wires. The third wire is not used and must be properly terminated.

All units are shipped wired as specified by factory order. Conversion between single-phase and three-phase can be accomplished by referring to phase loading and line amperes chart on wiring diagram for wire size and ampere requirements.

NOTICE

This appliance, when installed, must be electrically grounded in accordance with local codes, or in the absence of local codes, with the *National Electrical Code, ANSI/NFPA 70* or the *Canadian Electrical Code, CSA C22.2, as applicable.*

WARNING



This appliance (120V ovens only) is equipped with a three-prong (grounding) plug for your protection against shock hazard and should be plugged directly into a properly grounded three-prong receptacle. Do not cut or remove the grounding prong from this plug.

STEP 7: CONNECT ELECTRICITY SUPPLY

STEP 8: CONNECT GAS SUPPLY

The installation must conform with local codes, or in the absence of local codes, with the *National Fuel Gas Code*, *ANSI Z223.1, Natural Gas Installation Code*, *CAN/CGA-B149.1*, or the *Propane Installation Code* *CAN/CGA-B149.2*, as applicable, including:

1. The appliance and its individual shutoff valve must be disconnected from the gas supply piping system during any pressure testing of that system in excess of 1/2 psi (3.45 kPa).
2. The appliance must be isolated from the gas supply piping system by closing its individual manual shutoff valve during any pressure testing of the gas supply piping system at test pressures equal to or less than 1/2 psi (3.45 kPa).

NOTICE

A 3/4" NPT line is provided at the rear for the gas connection.

If this equipment is being installed at over 2,000 feet altitude and that information was not specified when ordered, contact the appropriate authorized Southbend Service Representative or the Southbend Service Department. Failure to install with proper orifice sizing will result in poor performance and may void the warranty.

The serial plate is located inside the front lower panel. It indicates the type of gas the unit is equipped to burn. All Southbend equipment is adjusted at the factory. Check type of gas on serial plate.

These models are design-certified for operation on natural or propane gases. For natural gas, the regulator is set to deliver a 4.0" W.C. pressure to the manifold. For propane gas, it is set to deliver 11" W.C.

This appliance should be connected ONLY to the type of gas for which it is equipped. The inlet pressure before the regulator should be 7-10" W.C. for natural gas or 11-14" W.C. for LP gas.

An adequate gas supply is imperative. Undersized or low pressure lines will restrict the volume of gas required for satisfactory performance. Fluctuations of more than 25% on natural gas or 10% on propane gas will create problems and affect burner operating characteristics.

An adequate gas supply line to the unit should be no smaller than the I.D. of the pipe from the unit to which it is connected.

Purge the supply line to clean out dust, dirt, or other foreign matter before connecting the line to the unit.

CAUTION

ALL PIPE JOINTS AND CONNECTIONS MUST BE TESTED THOROUGHLY FOR GAS LEAKS. USE ONLY SOAPY WATER FOR TESTING ON ALL GASES. NEVER USE AN OPEN FLAME TO CHECK FOR GAS LEAKS. ALL CONNECTIONS MUST BE CHECKED FOR LEAKS AFTER THE UNIT HAS BEEN PUT INTO OPERATION. TEST PRESSURE SHOULD NOT EXCEED 1/4" W.C.

STEP 9: CHECK INSTALLATION

1. Check that all screws and bolts are tightened.
2. Move the oven into the position at which it will be operated.
3. Check that the oven is level. If not, adjust the legs.
4. Check that the appropriate clearances are satisfied (see page 4).



- Models with **Standard Controls** are the most similar to a standard (non-convection) oven. Instructions for operating this type of oven begin on page 21.
- Models with **Cycle/Cook and Hold Controls** enable you to have the oven automatically enter a "hold mode" after a timed cooking period. Instructions for operating this type of oven begin on page 23.
- Models with **Touch Controls** are the most versatile option allowing for manual cooking with cook and hold, as well as programming recipes and cooking groups. Instructions for operating this type of oven begin on page 26.

The oven will have one of the three types of control panels:

A convection oven is a different type of oven that offers many features and advantages to the food service operation. The additional capabilities and features of the oven require some learning. However, the operation of the oven is not difficult to understand or control once you have some practice.

OPERATING THE CONTROLS

To shutdown the oven, switch the power switch to the "OFF" position. For a complete shutdown, also open the control panel and turn the manual shut-off valve to the "OFF" position.

To light the oven, just switch the power switch at the top left corner of the control panel to the "ON" position. (The oven is equipped with a direct hot surface ignition system. There is no pilot to light.) For TC models only, the power switch must be set to the "ON" position, the touchscreen must be active, and a mode selected, such as pressing Manual, selecting a recipe, or choosing a rack group, in order to light the oven.

If the burners fail to ignite within four seconds, the oven will automatically shut off the gas, wait five minutes to allow the gas that was released to dissipate, and try to light the burners again. If the burners still fail to ignite after three such attempts, the oven will stop trying, even though the power switch is in the "ON" position. To continue to attempt to light the burners, turn the power switch "OFF" and then "ON" again.

LIGHTING, RELIGHTING, AND SHUTDOWN INSTRUCTIONS

<p>NOTICE</p> <p>For an appliance equipped with a convection oven, no attempt should be made to operate oven during a power failure.</p>

<p>CAUTION</p> <p>To eliminate gas build up which could result in an explosion, in the event of main burner ignition failure a five minute purge period must be observed prior to re-establishing ignition source.</p>

<p>EXPLSION HAZARD</p> <p>DANGER</p> <p>In the event a gas odor is detected, shut down equipment at the main shut off valve. Immediately call the emergency phone number of your gas supplier.</p>
--

OPERATION

Figure 7

Control Panel of STANDARD Models

Power Switch

Switch ON to use the oven, switch OFF when done using the oven.

Cook Timer

Turn knob to set a time duration. An alarm will sound when the timer runs out. The timer is a reminder to the user; **the timer does not control the oven.**

Cook Temperature Control

Turn knob to select desired cooking temperature. The Heat On indicator will go out when the oven reaches the set temperature, and will cycle on and off as the burners operate to maintain the set cooking temperature.

Oven Interior Light Switch

On ovens equipped with an oven interior light, press to turn on the light. The light remains on for as long as the switch is held.

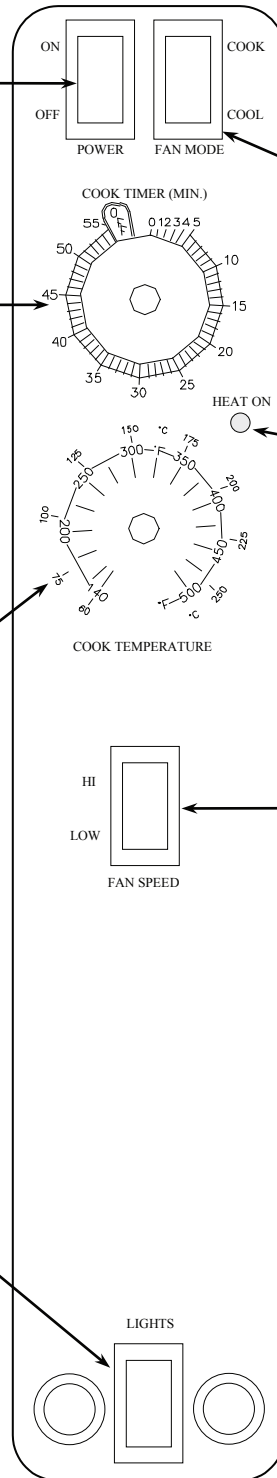

Fan Mode

In COOK mode, the fan runs continuously except when the doors are open. The fan does NOT cycle with the operation of the burners. In COOL mode, the fan runs continuously even if the doors are open. Since the burners will not operate if the oven doors are open, to rapidly cool the oven after cooking is completed, open the doors and switch the fan mode to COOL.

Heat-On Indicator

Indicator is lit when the burners are operating.

Fan Speed

Use to select fan speed (HI or LOW). The appropriate speed is determined by the type of food being cooked.

OPERATION OF STANDARD MODELS

Models with Standard Controls operate much like a standard oven: you turn the oven ON and select a cooking temperature. Two additional controls are used to control the fan (as described below).

The timer is a reminder to you of when to remove food from the oven.

The timer does NOT control the temperature of the oven.

To cook, do the following:

1. Turn the oven ON using the Power Switch at the top of the control panel.
2. Select the desired fan speed using the Fan Speed switch. The appropriate fan speed (HI or LOW) depends on the type of food being cooked.
3. Switch the Fan Mode switch to COOK. The fan will run continuously when the oven doors are closed (the fan does not cycle on and off with the burners). (If this switch is set to COOL the only difference is that the fan will continue to run when the oven doors are open.)
4. Set the cooking temperature by turning the Cook Temperature Control until the indicator mark on the knob is pointed to the desired cooking temperature. The Heat On indicator will light when the burners are on, and will remain on while the oven preheats.
5. Wait until the Heat On indicator has come on and gone out three times. At that time the oven will have reached the set cooking temperature.
6. Open the oven doors, load the product into the oven, and close the doors.
7. You can use the Cook Timer as a reminder of when to remove the load from the oven. If so desired, turn the Cook Timer knob until the indicator mark points to the desired cooking time (up to 55 minutes). The timer knob will rotate counterclockwise as the timer runs down, indicating how much time remains. You can turn the knob while cooking to increase or decrease the remaining time. When the timer runs out, a buzzer will sound for a short time, then turn itself off. (To immediately silence the buzzer, turn the Cook Timer knob to the OFF position.) The timer is a reminder to you; **the timer does not control the oven.**

If you open the oven doors, the burners in cool mode will shut off until the doors are closed. However, the timer will continue running even if the doors are open.

For ovens that are equipped with an oven interior light, to turn on the light press and hold the switch located at the bottom of the control panel.

8. When the load has finished cooking, you can rapidly cool the load by opening the oven doors (which will shut off the burners) and switching the Fan Mode to COOL (which will cause the fan to run even though the doors are open). For the most rapid cooling, also switch the Fan Speed switch to HI.
9. When you are done cooking, turn the Cook Temperature control to the lowest setting (fully counterclockwise) and switch the Power Switch to OFF.

Figure 8

Control Panel of CYCLE/COOK and HOLD Models

Power Switch

Switch ON to use the oven, switch OFF when done using the oven.

Time Display

Displays time setting. Indicator lights indicate whether the numbers shown represent hours-and-minutes or minutes-and-seconds.

Temperature Display

Displays cook-temperature setting.

Heat-On Indicator

Indicator is lit when the burners are operating.

Hold Mode Indicator

Lights when Hold mode has been enabled.

Hold Mode Button

Press to toggle Hold Mode on or off. To set the Hold temperature, press and hold this button while adjusting the temperature.

Cook Start/Stop Button

Press to start a timed cook period whose duration is shown in the TIME window. During a timed cook period, the TIME window displays the remaining time. To stop cooking, press this button again.

Oven Interior Light Switch

On ovens equipped with an oven interior light, press to turn on the light. The light remains on for as long as the switch is held.

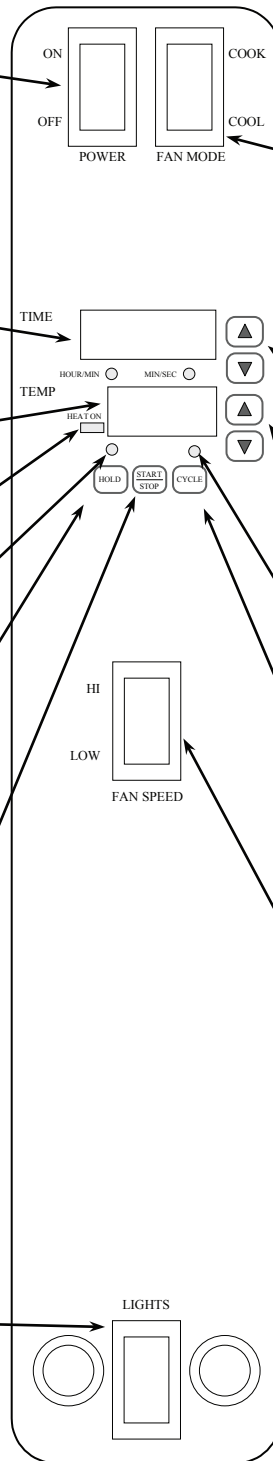

Fan Mode

In COOK mode, the fan runs except when the doors are open. The fan does NOT cycle with the operation of the burners. In COOL mode, the fan runs continuously even if the doors are open. Since the burners will not operate if the oven doors are open, to rapidly cool the oven after cooking is completed, open the doors and switch the fan mode to COOL.

Timer Adjustment Buttons

Press the up-arrow button to increase the time setting; press the down-arrow button to decrease the time setting.

Temperature Adjustment Buttons

Press the up-arrow button to increase the temperature setting; press the down-arrow button to decrease the temperature setting.

Fan Cycle Indicator

When on continuously the fan will run continuously. When flashing, fan will cycle on-and-off.

Fan Cycle Button

Press to select whether the fan runs continuously, or cycles on and off.

Fan Speed Switch

Use to select fan speed (HI or LOW). The appropriate speed is determined by the type of food being cooked.



9. Open the oven doors and insert a load into the oven. Close the doors and press the Start/Stop button. The oven will enter Cook Mode and the time display will start to count down the remaining cook time.
8. Wait until the oven has reached cooking temperature.

Care should be exercised in holding products over extended periods of time or at very low holding temperatures, due to possible bacteria growth. A competent authority on food bacteria growth should be consulted if there is doubt regarding safe holding times and temperatures.

CAUTION

7. If you want the oven to enter a lower-temperature Hold Mode after a timed cook period, press and hold down the Hold button. The temperature display will now show the oven temperature (140°F to 200°F) desired during the hold mode. You can change the desired holding temperature using the up-arrow and down-arrow buttons to the right of the temperature display window (while holding down the Hold button). If you want the oven to enter Hold Mode after the cook time, be sure that the Hold Mode Indicator is lit (if it is not, press and release the Hold button so that it becomes lit). Note that when Hold Mode starts the actual oven temperature will not immediately drop to the holding temperature since it takes time for the oven interior and the load itself to cool.
6. Select the desired cooking time by pressing the up-arrow and/or down-arrow buttons to the right of the time display window. Holding down a button will speed-up the rate at which the displayed value changes. Lights under the displayed time indicate if the displayed time is in minutes-and-seconds or in hours-and-minutes. The time setting will not start counting down until you tell the oven to start cooking (in Step 9).
5. Select the desired fan speed by pressing the Fan Speed switch. The appropriate fan speed (HI or LOW) depends on the type of food being cooked.
4. Select whether you want the fan to cycle during cooking by pressing the Cycle button. If the Cycle indicator light is on continuously, the fan will run continuously. If instead the Cycle indicator light is flashing, the fan will cycle on for 30 seconds and then off for 30 seconds while cooking. Fan cycling is used for delicate products such as meringues and muffins which need to set, and is usually combined with the LOW fan speed (selected in the next step).
3. Switch the Fan Mode switch to the COOK position (if it is not already in that position). The fan will run when the oven doors are closed (the fan does not cycle on and off with the burners). (If this switch is set to COOL the only difference is that the fan will continue to run when the oven doors are open.)
2. Set the desired cook-temperature (from 150°F to 500°F) by pressing the up-arrow and/or down-arrow buttons to the right of the temperature display window. The Heat On indicator will light when the burners are on. To view the actual oven temperature at any time, press the up-arrow and down-arrow buttons simultaneously.
1. Turn the oven ON using the Power Switch at the top of the control panel. The oven will be in Cook Mode, and will begin to heat to the temperature displayed in the temperature display window.

To cook, do the following:

Whenever the power switch is on, the oven will be in one of two modes. In **Cook Mode**, the oven maintains the specified cook temperature and the fan runs continuously, unless the Cycle option is enabled, in which case the fan cycles (on for 30 seconds, then off for 30 seconds). In **Hold Mode**, the oven maintains the specified hold-temperature and the fan runs only when the burners are on. (However, whenever the Fan Mode switch is in the COOL position, the fan will run continuously.)

hold-temperature for an indefinite period of time.

temperature for a specified time period, then enter an optional Hold Mode during which the oven maintains a specified CYCLE/COOK and HOLD models have electronic controls that enable the oven to cook food at a specified cook-

OPERATION OF CYCLE/COOK AND HOLD MODELS

If you open the oven doors, the fan and burners will temporarily shut off, and the time display will pause until the oven doors are closed again.

For ovens that are equipped with an oven interior light, to turn on the light press and hold the switch located at the bottom of the control panel.

During the cook time you can start or stop having the fan cycle on-and-off by pressing the Cycle button.

If necessary, you can adjust the remaining cooking time and/or oven temperature using the corresponding up-arrow and down-arrow buttons. You can also disable or enable Hold Mode.

To cancel a timed-cook, press the Start/Stop button.

10. What happens when the cook time runs out depends on whether Hold Mode is enabled.

- If Hold Mode IS NOT enabled, the oven will start “beeping” and the time display will flash “:00”. Press the Start/Stop button to silence the alarm and the oven will return to Cook Mode. Promptly remove the load from the oven OR open and leave open the oven doors. **If the oven doors are shut, the oven will maintain the set cook temperature even though the timer has run out.** To rapidly cool down the load, open the doors, switch the Fan Mode switch to COOL, and switch the Fan Speed switch to HI.
- If Hold Mode IS enabled, the oven will beep 3 times to alert you that the cook time has completed. The time display will start counting up to indicate how long the load has been in Hold Mode (up to 99 hours). The temperature display will change to show the holding temperature (set in Step 7) and the burners will remain off while the oven gradually cools to the holding temperature. With the doors closed, the oven will maintain the set holding temperature until you press the Start/Stop button (usually after removing the load). Pressing the Start/Stop button returns the oven to Cook Mode, and the oven will then heat up to the specified cook temperature in anticipation of the next load to be cooked.

11. When you are done cooking, switch the Power Switch to OFF.

Figure 9

Control Panel of Standard Touchscreen Models

Power Switch
Switch ON to use the oven, switch OFF when done using the oven.

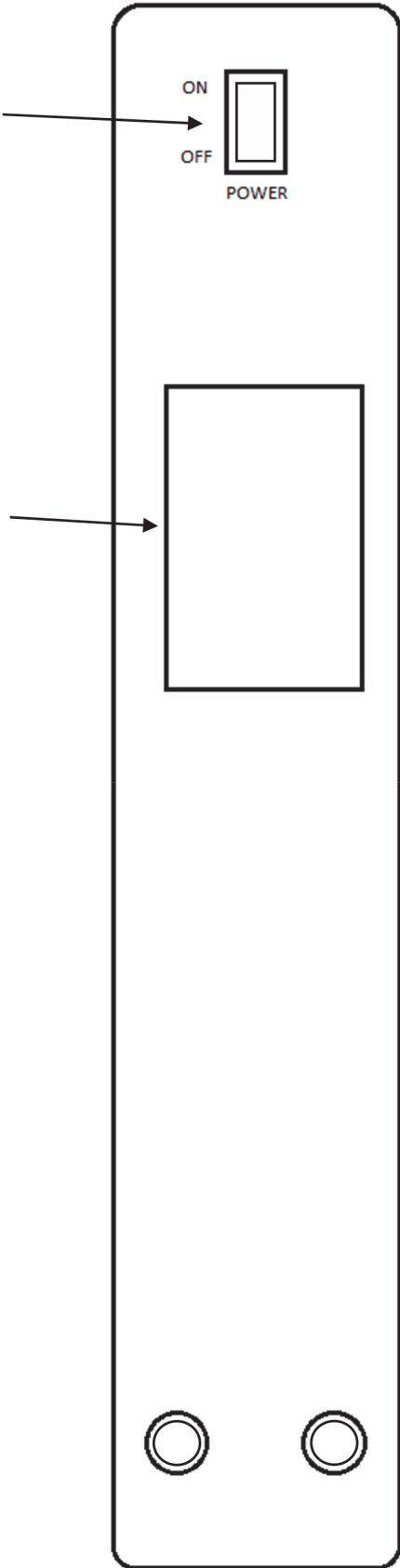

Digital Touch Control
All functions are controlled through this panel including temperature, time, lights, and fan speeds. Fan pulse and Cook & Hold are included.

Figure 10

Control Panel of Touchscreen Models with NRG Mode

Power Switch

Switch ON to use the oven, switch OFF when done using the oven.

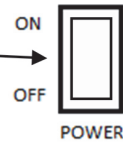

Digital Touch Control

All functions are controlled through this panel including temperature, time, lights, and fan speeds. Fan pulse and Cook & Hold are included.



NRG Mode Indicator

Indicator is lit when the NRG system is actively working.



OPERATION FOR TOUCHSCREEN MODELS ONLY

MAIN SCREEN

1. Turn **Power Switch** ON.

NOTICE

All button pushes will cause the buzzer to make a chirp (see Settings in Configuration section to adjust volume).

2. **Power Button** – Located in the center of the screen below the Southbend logo, pressing this button leads to the Cooking Mode Page.
3. **Lights** – Turns oven light ON/OFF. Button will illuminate and bulb will glow yellow when ON and can be turned OFF on any other page.

NOTICE

Not all units have lights installed. Button will still be present. Turning light ON with one page will continue to keep light on through the different pages.

Figure 11

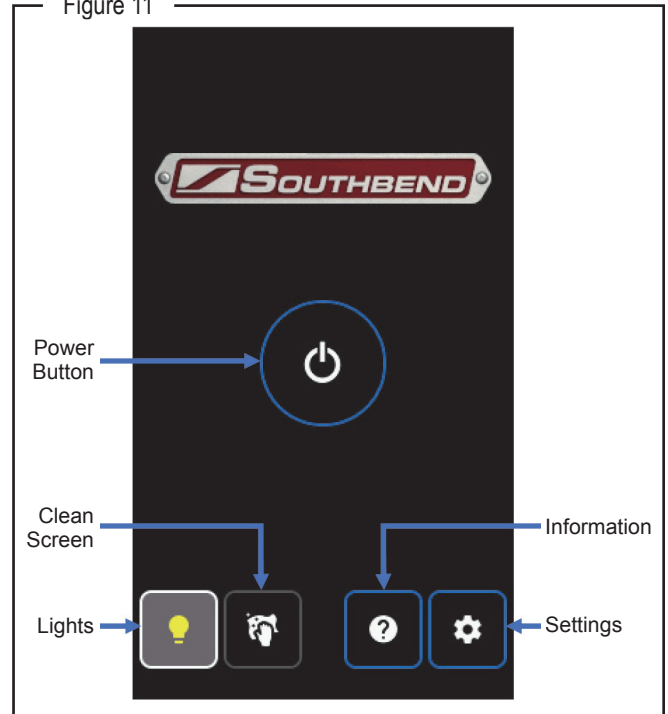
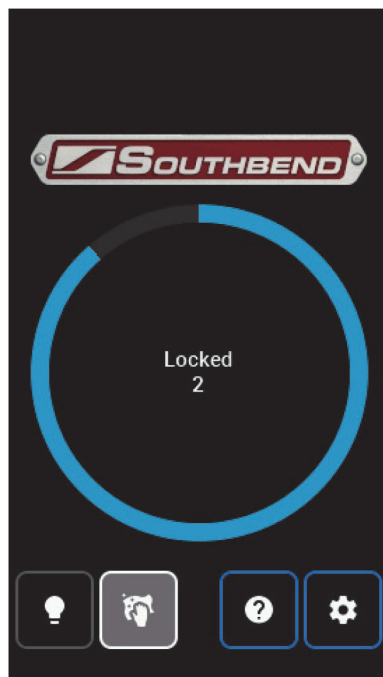
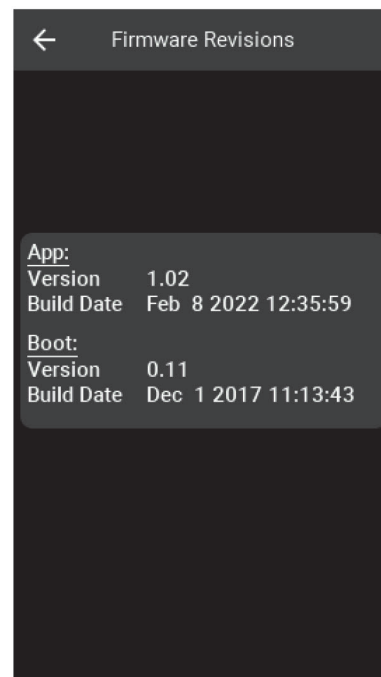

Figure 12



Clean Screen



Information

4. **Clean Screen** – Press and hold until countdown wheel appears with countdown timer in center of screen. Screen will be locked for cleaning for 20 seconds. After blue wheel has completed circuit and countdown has reached 0, the screen will be accessible again.
5. **Information** – Firmware information displays App version with build date and Boot version with build date.
6. **Settings** – Opens Settings Page (see Settings in Configuration section).

COOKING MODE

Disclaimer: All recipes provided in this manual are for reference only and do not reflect real cook times and temperatures. For suggested times and temperatures for recipes, see Cooking Hints section.

1. **Power Button** – Sends user back to Main Screen. Resets all cooking modes by ending current cooking options and terminates blower and heat source.

NOTICE

Once a cooking mode/selection has been previewed, the blower will turn on automatically and the Cooking ribbon will relay its status. With the door closed, the heat source will remain on indefinitely while internal temperature is below cook temperature until the oven preheats or the Power Button is pressed.

2. **Manual** – Operate cooking controls manually.
3. **Recipe** – User created recipes, either manually entered or imported by service USB, to cook with the press of a button.
4. **Rack** – Recipe groupings cooking together based on number of configured racks, cook time, and cook temperature.
5. **Clean Panel** – See Main Screen.
6. **Cool Down** – Turns on Fast blower speed, pauses heat sources, and returns to Main Screen. Cool Down mode terminates when internal temperature falls below 130°F/55°C, the Power Button on Cooking Mode page is selected, or when a cooking mode is activated.
7. **Information** – See Main Screen.
8. **Settings** – See Settings in Configuration section.

Figure 13

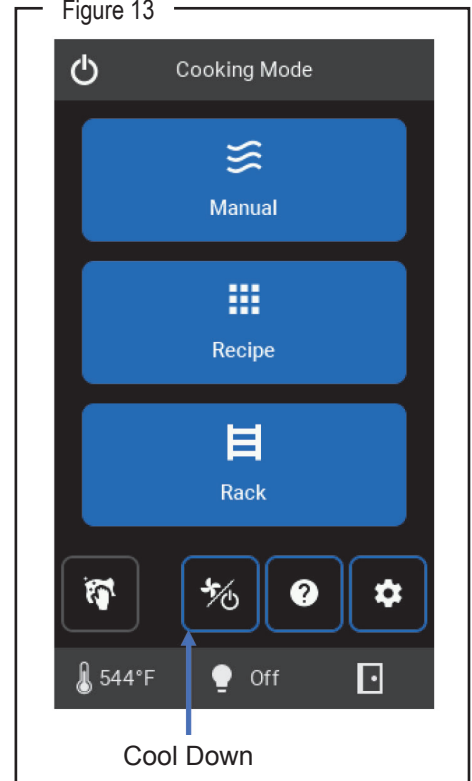

NOTICE

At the end of a cooking cycle the buzzer will chime on and off until the mode is canceled or reset.

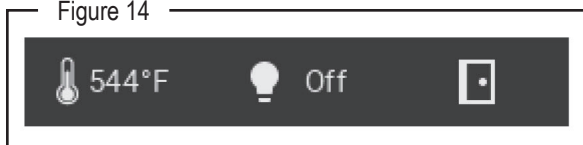

Bottom Ribbon (seen at the bottom of each cooking mode page, but not on the cooking mode selection page)

Figure 14



9. **Internal Temperature**

10. **Lights** – See Main Screen.

11. **Door Indicator** – Closed  Open 

NOTICE

Door must be closed to run fans, and subsequently heat source. Blower will still run with door open only in Cool Down mode. Any cook timer that is active when door opens will pause and resume when door is closed.

MANUAL COOKING

MANUAL COOKING SETUP

NOTICE

All selections are remembered after a cooking cycle has begun and will be recalled upon return to the page until power is cycled. If selections were made but Cook was not pressed or the power was cycled, the selections will return to previous default settings.

1. Set cooking temperature (140 °F – 550 °F/60 °C – 288 °C) either by using the add/subtract buttons or by selecting the temperature itself. Using the add/subtract buttons steps the temperature by ± 10 °F/5 °C. Selecting the temperature will lead to a number pad (see Number Pad in Configuration section for how to use). Temperatures keyed above or below the range will not be accepted and will output the closest min or max.

NOTICE

If internal temperature is below the set temperature minus Ready Offset Temperature, top ribbon will appear with Preheating message and Cook will not be accessible. When the cook temperature is achieved, the ribbon will read Ready and cooking may begin. If the temperature of the oven starts above the cook temperature the ribbon will read Too Hot until it cools to the desired temperature. The top ribbon will read Cooling when Cool Down is active (see Cooking Mode).

2. Set Time either by using the add/subtract buttons or by selecting the time itself. Using the add/subtract buttons steps the time by ± 10 seconds. Upon reaching an hour the format will change from MM:SS to HH:MM. Selecting the time will lead to a number pad. MM:SS or HH:MM can be selected before keying in time. Keying in a time above 59:59 in MM:SS will change the format to HH:MM. Max time is 24 hours.
3. Press the Blower Speed button (Blower Logo) to toggle blower speed between Fast and Slow.
4. A delay time can be set to temporarily shut off blower and heat source before cook starts. Delay time is included in total cook time. Max delay time is one hour.
5. Pulse ON/OFF is used to cycle blower. Maximum set time is 1 hour for each, and the minimum set time is 10 seconds. If Pulse ON is set to 0 seconds and Pulse OFF has a value, the time for both will be set to 0 seconds when cook cycle begins.
6. Enable Cook & Hold to keep the cabinet warm once cook time is finished. Enabling this mode will require a hold temperature within cook temperature limits (generally low to hold food before serving without overcooking). A timer shows how long Cook & Hold has been active. Hold temperature is not immediately reached and should be factored. During Cook & Hold, temperature, blower speed, delay, and pulse times can all be changed.

Figure 15

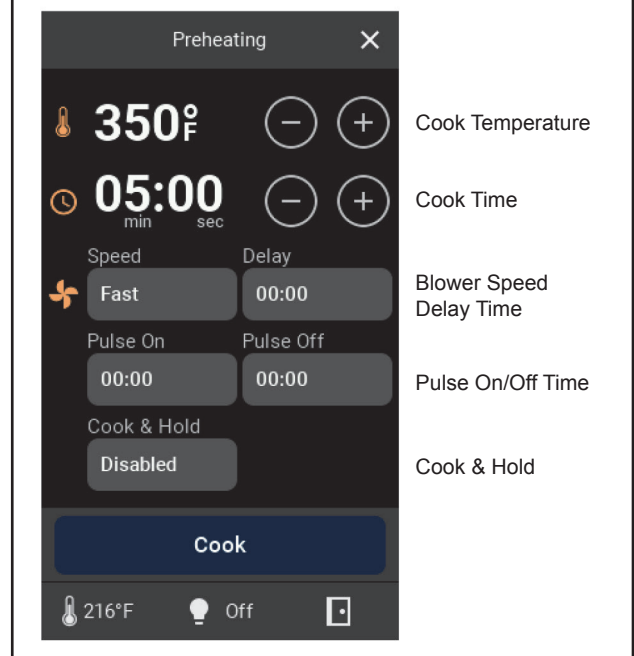

MANUAL COOKING CYCLE

NOTICE

All cooking parameters can be altered during cycle by pressing the desired value or icon. Pressing and holding on the screen will highlight the parameter logo in yellow that will be selected after release. Each parameter, besides Blower Speed, will open associated number pad to make numerical changes. Any changes made on Cycle page will not be saved upon return to Setup page.

1. **Cook Time** – Displays cook time in either MM:SS or HH:MM with a circular bar that grows as time progresses. Time can be altered at any point by either using the add/subtract 1m buttons to add or subtract 1 minute from the time, or else clicking on the time itself. The red X will cancel the cooking operation and send the user back to the Manual Cooking Setup page. At the end of the timer an alarm will sound.
2. **Cook Temperature** (°F/°C setup in configuration)
3. **Blower Speed** (Fast/Slow)
4. **Delay** time before cook
5. **Blower Pulse** (intermittent fan and heat source ON/OFF)

RECIPE COOKING

Recipes can be imported ahead of time using the service USB input (see Recipes in Configuration section) or can be manually created by pressing the New button. Recipes allow users to perform complex cooking operations with up to 5 different stages of cooking temperatures, blower speeds, delays, and/or pulses. This section will cover how to create a new recipe from the page and how to operate the recipe.

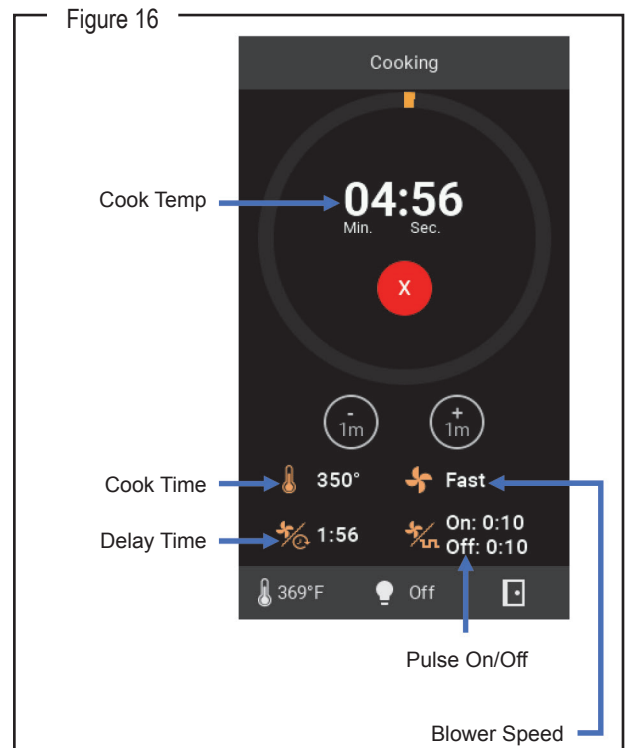

NOTICE

If editing has been locked, recipe creation and recipe manipulation is not possible from this screen. Manual Cooking is not affected by editing lockout.

NEW RECIPE SETUP

NOTICE

While in Setup the unit blower and heat source will turn off.

Figure 17

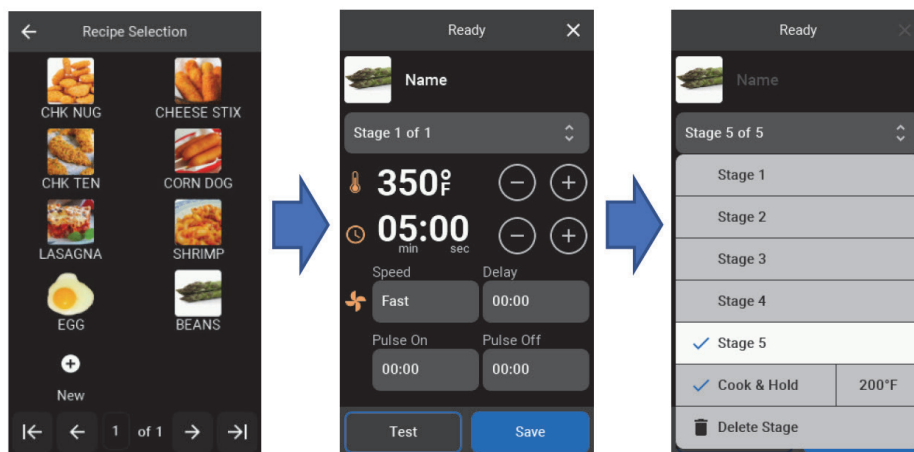

1. Click on New icon to create new recipe. If New icon is not present, select next page until it appears.
2. Click on the picture icon in top left and choose from the list of icons to represent the new recipe item. Click the back button and write the name of the recipe in Name. Hit enter when done.
3. Choose the parameters for Stage 1 just as in Manual Cooking Setup.
4. Press Test to run the recipe to ensure the recipe is accurate if necessary.

- If finished, press the Save button. Otherwise, press the Stage drop-down menu to add more stages. If Save button is not pressed a prompt will pop up asking to save changes when exiting setup page.
- Press Add Stage to add another stage for setup.
- Repeat steps 2-5 for up to 5 stages. A cook and hold can be added at the end of the recipe without it counting as one of the stages.

NOTICE

After recipe has been created, returning to the recipe from the selection menu allows the user to edit the recipe unless this option has been locked. Clicking on the Stage drop-down menu while editing will reveal the Delete Recipe button.

RECIPE RUN

- Select Recipe from Cooking Mode page.
- Select the desired recipe from the list in selection menu.
- All stages will be previewed showing the time of each stage, temperature, blower speed, any delays, any pulse times, and the total cook time.
- If the temperature is too low the top ribbon will read Preheating and Cook button will not be available until reaching the cook temperature. If the temperature is too hot the top ribbon will read Too Hot and Cook button will not be available until the internal temperature cools to cook temperature.
- After pressing Cook, the run page appears like Manual Cooking Cycle and can be altered in the same way unless locked. The cook time will show total time while the stage number and time remaining for that stage will appear below.

Figure 18

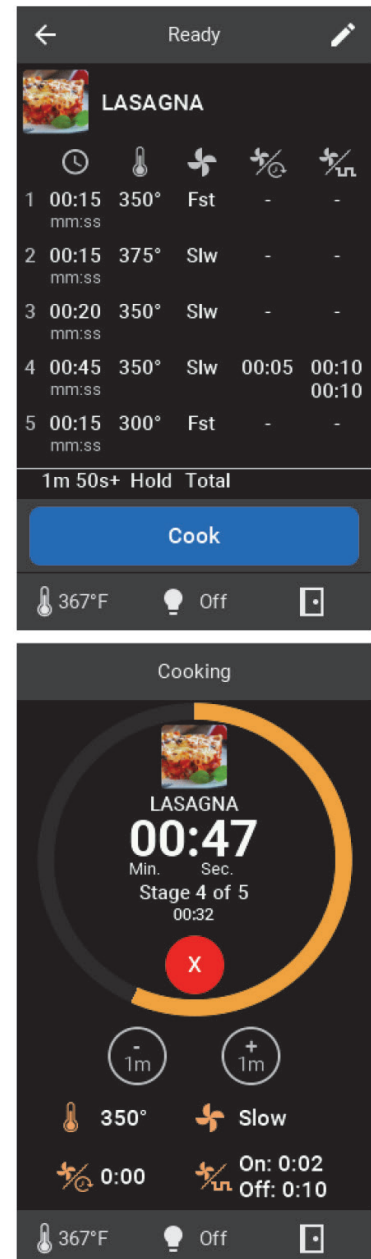

RACK COOKING

Rack Cooking is used to cook recipes of similar cooking temperature and fan speed (Rack Group) simultaneously. Recipes need to be created ahead of time to make Rack Groups. Similar recipe cooking temperature is defined within the limits of the Group Temp Allowance temperature added to the cook temperature of the first item in the group (see example). Recipes that have multiple stages cannot be included in Rack Groups. See Settings in Configuration to change the Group Temp Allowance.

Example: With a Group Temp Allowance of 10 °F, a recipe that cooks at 350 °F can be grouped with a recipe that cooks at 340 °F and/or a recipe that cooks at 360 °F. If the first recipe chosen though is 340 °F cook temperature, then the 360 °F recipe will not appear during group creation.

RACK SETUP

1. Choose the edit button in the top right corner.
2. A New square will appear on the screen in the next available space on the final Group Selection page. Once identified press the square.
3. Enter desired group name and press the blue arrow button to accept.
4. Selecting a recipe from the next page will show the cook temperature and fan speed as well as all other recipes that are similar (Figure A). Pressing each different recipe will highlight them with a green box. If only one recipe is selected, pressing the highlighted box will return all available recipes. If two items are selected, deselecting the first recipe chosen will change the group parameters to the new “first” selection and may reveal more similar recipes (see written example above and Figure B). When more than two selections are made, deselecting the first recipe selection does not change the group similarity parameters (Figure C).

Figure 19



Figure 20

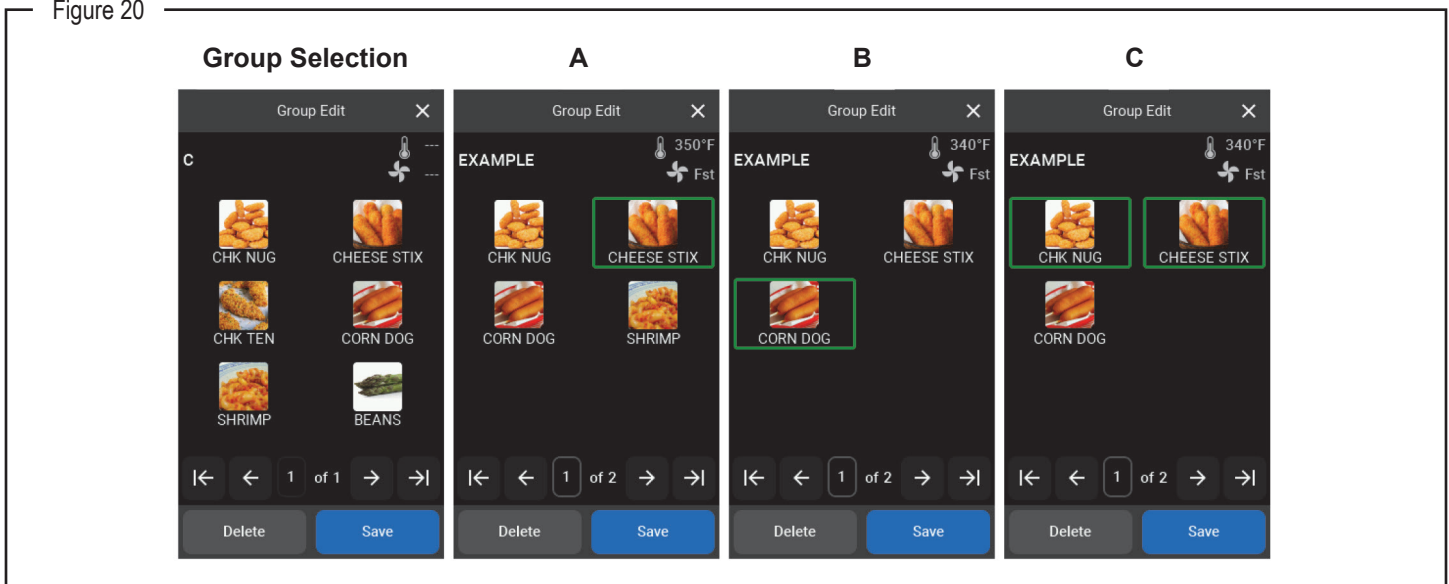

5. Once all desired recipes are chosen, press the save button.
6. The rack can be deleted at any time during creation or editing.
7. The group image will show the first three recipe icons with the total number of group recipes available numerically represented in the last space.

RACK RUN

1. Select Rack from Cooking Mode page.
2. Select the recipe group from Group Selection page.
3. If internal temperature is lower than the group temperature the top ribbon will read Preheating and if above, it will read Too Hot.
4. After reaching the correct internal temperature, the blower speed will be adjusted to the group speed.
5. The group will show Not Assigned spaces initially. To add recipes, choose the top right 9 square button. This will show all available recipes for this group as defined during creation in the selection menu or imported prior.
6. Choose a recipe and it will return to the previous page.
7. By pressing on a rack space, the icon will be attached to that space and show a timer, additional time button, and start button. Empty racks will remain empty until a recipe is placed in that space.

Figure 21

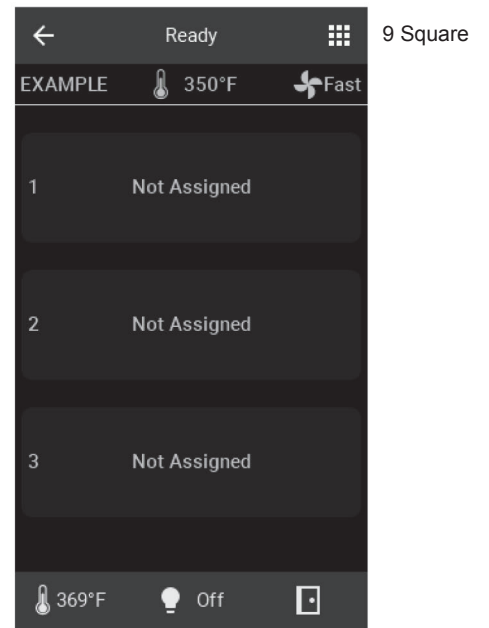
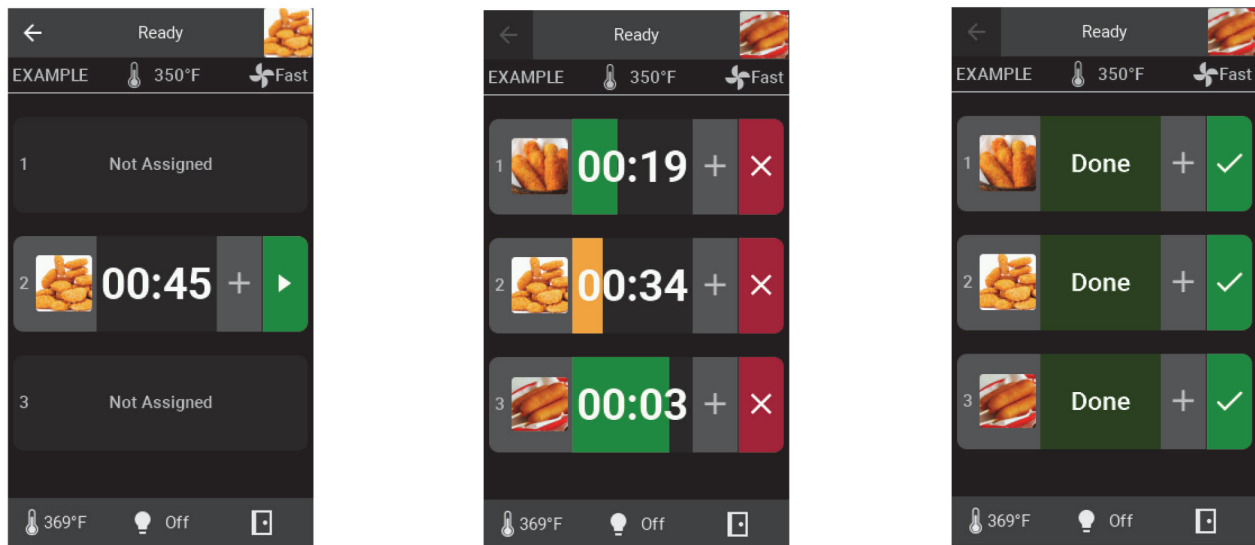

Figure 22



8. Choosing the start button will start the recipe and time can be added in one-minute increments. A progress bar depicts the time left. The bar starts as an amber indicator and changes to green at 20 seconds.
9. When finished, the progress bar will blink alternatively a lighter and darker green and say DONE. Press the green check mark to stop and reset recipe. Pressing the check mark will also allow access to exit Rack Group which is not accessible with running and/or completed recipes.
10. Pressing the red X during the run will also stop the recipe and reset the time back to the programmed cook time.
11. Repeat steps 5-7 to fill racks with different recipes. The recipe icon in the top right shows which recipe is in the queue to add to racks. Pressing it allows selection of the other recipes. Recipes are overwritten when the rack is chosen with a different recipe. Racks that are currently cooking or completed cannot be overwritten until reset.
12. Returning to the Rack Group Selection page will clear all racks.

CONFIGURATION

SERVICE ONLY USB ACCESS

The access to the USB port to import/export recipes, update software versions, and add Icons is located on the back of the control panel. Remove the two screws securing the control panel and pull out. Underneath the digital display you will find the USB port. If importing files, make sure that the unit is off before inserting USB drive and then turn on. There will be a slight delay compared to normal operation and the file(s) will automatically load. Created Icons must be bitmap file type. Recipes will need to be created on the touchscreen prior to export.

SETTINGS

1. **Back Button** – Returns to previous screen.
2. **Setup** – Passcode protected parameter configurator. Manager passcode allows owners to change limited unit variables.
3. **Service** – Passcode protected unit health and I/O test panel with current input readings.

NOTICE

As in normal operation, blower speed must be activated prior to turning on heat. The door may be open or closed to function.

Figure 23

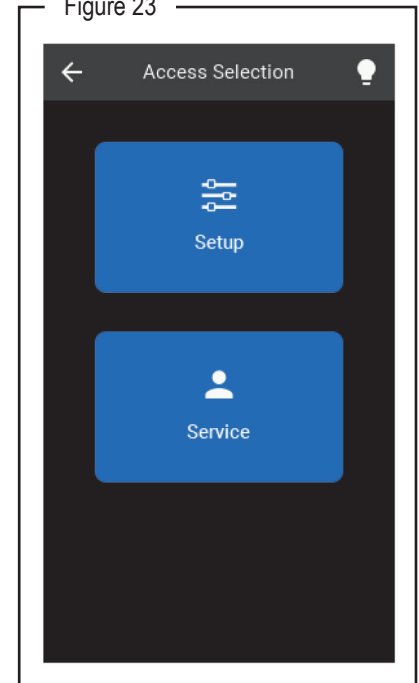

NUMBER PAD

- Entering a new value will start from the right and move left.
- Continuing to enter new numbers will shift the furthest left characters out.
- Press the bottom right arrow button to enter value
- Clear all values back to 0000 with bottom left clear button

Figure 24



SETUP

Enter manager provided code to enter Setup Parameters page.

Figure 25

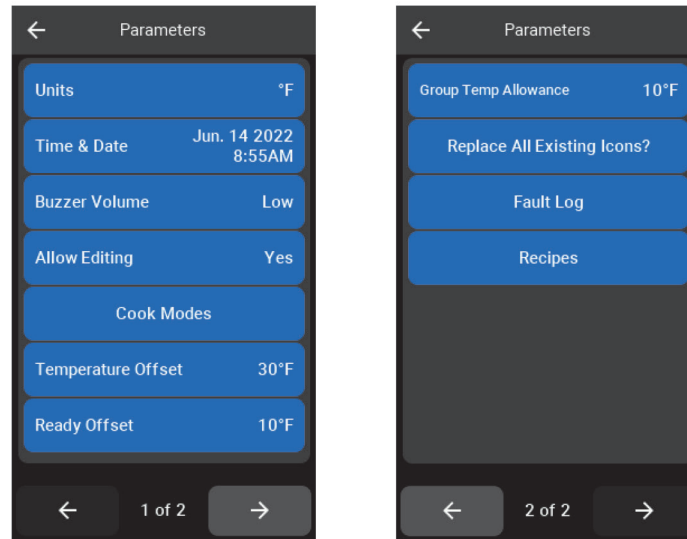

1. **Units** – Toggles between °F and °C
2. **Time & Date** – Used to record faults
3. **Buzzer Volume** – Toggle between High, Medium, and Low
4. **Allow Editing** – Toggle between Yes, Passcode, and No. This setting is in reference to editing recipes and groups. Selecting Passcode will require manager code to edit while selecting No will remove edit button from pages.
5. **Cook Modes** – Chooses which cooking modes will be active on Cooking Mode page.
6. **Ready Offset** – The oven will allow cook start operations if cavity temperature is within the offset value from cook setpoint.
7. **Group Temp Allowance** – Recipes can be grouped if their setpoints differ by allowance value or less.

Figure 26



8. **Replace All Existing Icons?** – Deletes current icons for recipes and uploads new ones if USB is inserted into USB slot.

- 9. **Fault Log** – Displays all faults that have occurred along with date and time they occurred until cleared. When a temperature warning is active the only options are to Turn Off the unit or go into Cool Down mode. The warning is only available if blower or heat source is already on, otherwise a ribbon with Cavity/Controls Too Hot is visible and does not allow activation of any cooking modes. The message will go away when the Temperature falls below 630°F. Probe warnings activate related message ribbon and do not allow cooking modes until the problem is fixed.

NOTICE

If Turn Off option from pop up is selected but the main power switch is still engaged the unit will simply reset and return to main screen.

Figure 27

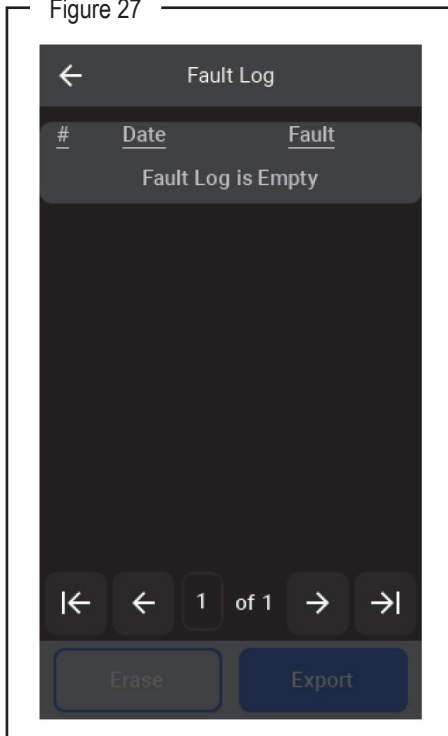

MESSAGE	DESCRIPTION
Open Probe	Averaged ADC readings indicate that the RTD is open
Shorted Probe	Averaged ADC readings indicate that the RTD is shorted
Cavity Too Hot	Averaged cavity temperature reading is 650 °F or higher. Temperature must fall below 630 °F to clear the fault.
Controls Too Hot	Averaged control cavity temperature reading is 176 °F or higher. Temperature must fall below 166 °F to clear the fault. This measurement is measured internally on the microcontroller.

- 10. **Recipes** – Allows Import and Export from USB to keep and manage recipes. Another option is to delete all recipes from unit. Deleting all recipes will also delete them from Rack Groups.

SERVICE

Service Screen supplies current input values and allows service agents to test outputs.

1. **Temperature** – RTD measured cavity temperature
2. **Probe Amp** – Used to determine open or shorted temperature probes
3. **Probe No Amp** – Used to determine open or shorted temperature probes
4. **CPU Temp** – Temperature of the display circuit board
5. **Door** – Open or closed
6. **Heat source**, blower and lights can all be toggled (fan must be on for heat to be active).
7. **0-10V Output** – Not in use.

Figure 28

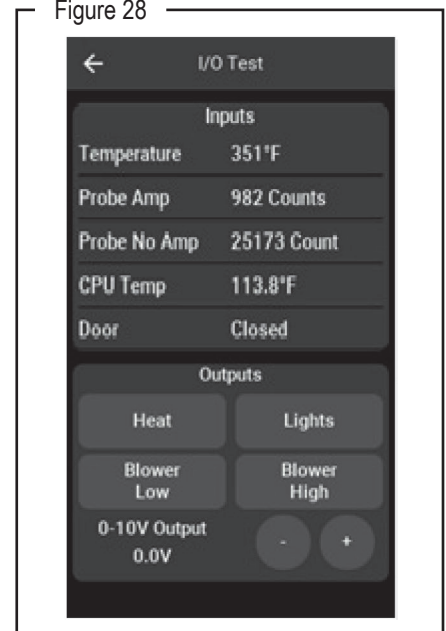



COOKING HINTS

In a standard (non-convection) oven, the air is relatively still and an insulating layer of moisture surrounds the cooking food product. In a convection oven, the fan-blow circulates air strips away this insulating layer allowing the heat to generate faster for quicker baking and roasting. Hence, in a convection oven cooking procedures and techniques may require some modification for successful results. As a general rule, the cooking time will be shorter and the cooking temperature will be 25 °F to 75 °F lower than those called for in recipes for a standard oven.

TIME & TEMPERATURE

Time and temperature are important. The "Guide to Times and Temperatures" later in this section is a starting point. The actual best cooking time and temperature will depend on such factors as size of load and mixture of recipe (particularly moisture). Once an appropriate time and temperature has been established for a particular product and load, you will find the result of succeeding loads to be similar.

OVERLOADING

Do NOT overload the oven. The size of the load that can be cooked satisfactorily depends largely on the particular product. As a rule, five racks can be successfully used for shallow cakes, cookies, pies, etc. For deeper cakes (such as angel food), use only three racks because of the size of the pan and the space required for rising. For hamburger patties, fish sticks, cheese sandwiches, etc., a full complement of racks and pans is usually satisfactory.

HELPFUL SUGGESTIONS

Here are some suggestions that will assist in getting the best possible performance from a convection oven:

- Pre-heat the oven thoroughly before use.
- When re-thermalizing frozen products, pre-heat the oven to 50 °F higher than the planned cooking temperature. After loading, reduce the temperature setting to the appropriate cooking temperature.
- Space the racks and pans as evenly as possible to allow air circulation.
- Center the load on the racks to allow for proper air circulation around the sides. Do not cover the racks completely with pans.
- Do not use a deep pan for shallow cakes or cookies, etc. Air circulation across the surface of the product is essential.

WARNING

THE USE OF ALUMINUM FOIL CAN CAUSE HEAT DISTRIBUTION PROBLEMS IN OVENS. EXTREME CARE MUST BE USED WHEN PLACING ALUMINUM FOIL IN THE OVEN TO ENSURE THAT IT DOES NOT BLOCK OR CHANGE THE AIR FLOW. THE USE OF ALUMINUM FOIL MAY VOID THE PRODUCT WARRANTY IF ITS USE IS ASCERTAINED TO BE A PROBLEM.

HOLDING FOOD BEFORE SERVING

Any food item prepared in steam table pans can be held until being served by setting the Hold thermostat to 160°F. Examples include stuffed pork chops, oysters Rockefeller, and any vegetable entree.

COOKING PROBLEMS AND SOLUTIONS

If...	then...
Cakes are dark on the sides and not done in the center...	lower oven temperature
Cake edges are too brown...	reduce number of pans or lower oven temperature.
Cakes have a light outer color...	raise temperature.
Cakes settle slightly in the center...	bake longer or raise oven temperature slightly. Do not open doors except to load or unload product..
Cakes ripple...	do not overload pans or use batter that is too thin.
Cakes are too coarse...	lower oven temperature.
Pies have uneven color...	reduce number of pies per rack or eliminate use of bake pans
Brown sugar topping or meringue blows off...	after oven is preheated, turn off oven and put product in oven until topping sets, then turn oven back on..
Rolls have uneven color...	reduce number or size of pans.
Meats are browned and not done in center...	lower oven temperature and roast longer..
Meats are well done and not browned...	raise temperature. Limit amount of moisture.
Meats develop hard crust...	reduce temperature or place pan of water in oven.
Excessive meat shrinkage occurs...	lower oven temperature..

GUIDE TO TIMES AND TEMPERATURES

As a guide, set oven temperatures 25 °F to 75 °F lower than called for in recipes for non-convection ovens, (i.e., range or deck ovens).

Time and temperature will vary depending upon load, mix, size, portion, initial temperature of food, and other factors. Use the following chart as a starting point to develop your own cooking techniques. Rack loading and position may affect results. Experimentation may be necessary to suit individual requirements.

	Cooking Time	Temperature	Number of Racks
Meat and Fish			
Top Round, 18-20 lbs. (medium)	5 hours	275 °F	1
Prime Ribs (rare)	4 hours	225 °F	1
Burger Patties, 4 oz.	10 hours	350 °F	5
Fish Cakes	10-12 min.	375 °F	5
Turkey, 10-12 lbs.	3 hr. 20 min.	225 °F	1

	Cooking Time	Temperature	Number of Racks
Baked Goods			
Bread, 2 lb. loaf	35 min.	375 °F	3
Biscuits	5-10 min.	400 °F	5
Cornbread.	18 min.	400 °F	5
French Bread	10 min.	375 °F	5
Sheet Cake	18-20 min.	300 °F	5
Cream Puffs	20 min.	375 °F	5
Brown & Serve Rolls	6 min.	400 °F	5
Ginger Bread	18 min.	300 °F	5
Yeast Rolls, sheet pan	16-18 min.	325 °F	5
Pineapple Upside Down Cake	25-30 min.	325 °F	5
Apple Turnovers	15-18 min.	350 °F	5
Fruit Cobbler	22-25 min.	375 °F	5
Brownies	15 min.	350 °F	5
Danish Pastry	12 min.	325 °F	5
Pie Shells	12 min.	350 °F	5
Fresh Fruit Pies	25-30 min.	350 °F	5
Pumpkin Pies	25-30 min.	275 °F	5
Fresh Apple Pies	35 min.	375 °F	5
Frozen Berry Pies	40 min.	375 °F	5
Frozen Fruit Pies	45 min.	375 °F	5
Potatos			5
Baked Potatoes, 10 oz.	50-55 min.	450 °F	5
Baked Potatoes, 6-8 oz.	40-45 min.	450 °F	5
Scalloped Potatoes	35 min.	325 °F	5
Miscellaneous			
Macaroni and Cheese	30 min.	350 °F	5
Stuffed Peppers	18 min.	350 °F	5
Toasted Cheese Sandwiches	8 min.	375 °F	5

CLEANING

Southbend equipment is sturdily constructed of the best materials and is designed to provide durable service when treated with ordinary care. To expect the best performance, your equipment must be maintained in good condition and cleaned daily. Naturally, the periods for this care and cleaning depend on the amount and degree of usage. Following daily and periodic maintenance procedures will enhance long life for your equipment. Climatic conditions (such as salt air) may require more thorough and frequent cleaning or the life of the equipment could be adversely affected. The oven interior is finished with a porcelain enamel coating. "Spillovers" should be cleaned from the interior bottom surface as soon as possible to prevent carbonizing and a burnt-on condition. Grease or any residue should be cleaned from interior surfaces as soon as it accumulates.



FOR YOUR SAFETY, DISCONNECT THE POWER SUPPLY TO THE APPLIANCE BEFORE CLEANING. WHEN CLEANING THE BLOWER WHEEL, BE SURE TO HAVE THE POWER SWITCH IN THE "OFF" POSITION.

DAILY CLEANING AND MAINTENANCE

1. Turn the power switch to OFF and allow the oven to cool.
2. Remove the oven-interior racks and rack slide frames. (The rack slide frames are readily removable by merely raising to disengage them from their sockets.) Wash the racks and rack slides in a sink with mild detergent and warm water. Dry them thoroughly with a clean cloth.
3. Look to see if any foreign matter has accumulated on the blades of the blower wheel (which will reduce air circulation). If necessary, remove the rear lining of the oven, which is secured by thumbscrews near each corner. Use a stiff brush to remove accumulations from the blower blades, then wash with soap and water.
4. Wash the interior surfaces with mild detergent and warm water. Rinse with clean water, and dry thoroughly with a clean cloth. For stubborn accumulations of grease and carbon build up, use a commercial Non-Caustic Oven and Grill Cleaner. Use of cleaners not specified as Non-Caustic may damage the unit.
5. Clean the control panel with warm water and mild soap. Never use cleaning solvents with a hydrocarbon base.
6. Wipe the other exterior surfaces with a clean damp cloth. If the exterior surfaces require more thorough cleaning, see "Cleaning Stainless Steel Surfaces" on the next page.
7. Return the rack slides and racks to their appropriate locations inside the oven.
8. LEAVE THE DOOR OPEN AT NIGHT AFTER CLEANING. This allows the oven to dry thoroughly after cleaning and also prolongs the life of the door gasket.

MONTHLY CLEANING

Clean around rear of motor (where the vent screen is located), louvered panels, and primary air holes in the rear of the oven where grease or lint may have accumulated.

SEMI-ANNUAL CLEANING

At least twice a year have your Southbend Authorized Service Agency or another qualified service technician clean and adjust the unit for maximum performance.

At least twice a year the oven's venting system should be examined and cleaned.

CLEANING STAINLESS STEEL SURFACES

To remove normal dirt, grease and product residue from stainless steel that operates at LOW temperature, use ordinary soap and water (with or without detergent) applied with a sponge or cloth. Dry thoroughly with a clean cloth.

To remove grease and food splatter, or condensed vapors, that have BAKED on the equipment, apply cleanser to a damp cloth or sponge and rub cleanser on the metal in the direction of the polishing lines on the metal. Rubbing cleanser, as gently as possible, in the direction of the polished lines will not mar the finish of the stainless steel. NEVER RUB WITH A CIRCULAR MOTION. Soil and burnt deposits which do not respond to the above procedure can usually be removed by rubbing the surface with SCOTCH-BRITE scouring pads or STAINLESS scouring pads. DO NOT USE ORDINARY STEEL WOOL, as any particles left on the surface will rust and further spoil the appearance of the finish. NEVER USE A WIRE BRUSH, STEEL SCOURING PADS (EXCEPT STAINLESS), SCRAPER, FILE OR OTHER STEEL TOOLS. Surfaces which are marred collect dirt more rapidly and become more difficult to clean. Marring also increases the possibility of corrosive attack. Refinishing may then be required.

To remove heat tint – Darkened areas sometimes appear on stainless steel surfaces where the area has been subjected to excessive heat. These darkened areas are caused by thickening of the protective surface of the stainless steel and are not harmful. Heat tint can normally be removed by the foregoing, but tint which does not respond to this procedure calls for a vigorous scouring in the direction of the polish lines, using SCOTCH-BRITE scouring pads or a STAINLESS scouring pad in combination with a powered cleanser. Heat tint action may be lessened by not applying, or by reducing heat to equipment during slack periods.

ADJUSTMENTS

GAS CONVECTION OVENS

ADJUSTMENTS

WARNING

ADJUSTMENTS AND SERVICE WORK MAY BE PERFORMED ONLY BY A QUALIFIED TECHNICIAN WHO IS EXPERIENCED IN, AND KNOWLEDGEABLE WITH, THE OPERATION OF COMMERCIAL COOKING EQUIPMENT. HOWEVER, TO ASSURE YOUR CONFIDENCE, CONTACT YOUR AUTHORIZED SERVICE AGENCY FOR RELIABLE SERVICE, DEPENDABLE ADVICE OR OTHER ASSISTANCE, AND FOR GENUINE FACTORY PARTS.

NOTICE

Warranty will be void and the manufacturer is relieved of all liability if service work is performed by other than a qualified technician, or if other than genuine Southbend replacement parts are installed.

LUBRICATION

The door chains and sprockets have been lubricated at the factory with high temperature "Never Seeze" lubricant. After each six months of usage, lubricate the door chains and sprockets with the same type of lubricant.

Motor lubrication information can be found on permanent label located on motor.

ADJUSTING GAS PRESSURE REGULATOR

The pressure regulator is factory set at 4.0" W.C. for natural gas and 11" W.C. for propane gas. To check the manifold pressure:

1. Turn all thermostats and burner valves to "OFF" position.
2. Turn main gas valve to entire unit off.
3. Remove valve panels and locate 1/8" plug in manifold.
4. Remove plug and install a fitting appropriate to connect a manometer.
5. Turn on main gas to unit and light pilots.
6. Turn all burners and ovens to full "ON" position and read manometer.
7. If manometer does not read 4.0" W.C. for natural gas, or 11" W.C. for propane gas, adjust regulator (if gas pressure is O.K. go to Step 10).
8. Remove cap from top of regulator.
9. With a screwdriver rotate regulator adjustment screw clockwise to increase, or counterclockwise to decrease, pressure until manometer shows correct reading.
10. Repeat steps 1 and 2.
11. Remove manometer fitting and replace plug in manifold.
12. Repeat step 5.
13. Replace valve panels.

ADJUSTING DOOR CHAIN MECHANISM

The door chain mechanism causes the left and right doors to open and close together. To adjust the door chain mechanism, do the following:

1. Remove lower front panel that covers the door chain mechanism (shown below).
2. Close both doors.
3. Check the positioning of the chain on the sprockets. There should be five regular links and one master link visible on the front side of each chain. If not, open the turnbuckles and reposition the chain over the sprockets.
4. Adjust the turnbuckles so that the right door closes about 1/4" to 1/2" inch ahead of the left door. The left door should be pushed tight over the friction catch so both doors are completely closed against the frame.
5. Secure the turnbuckles by tightening their locknuts.

Figure 29

Door Chain Adjustment

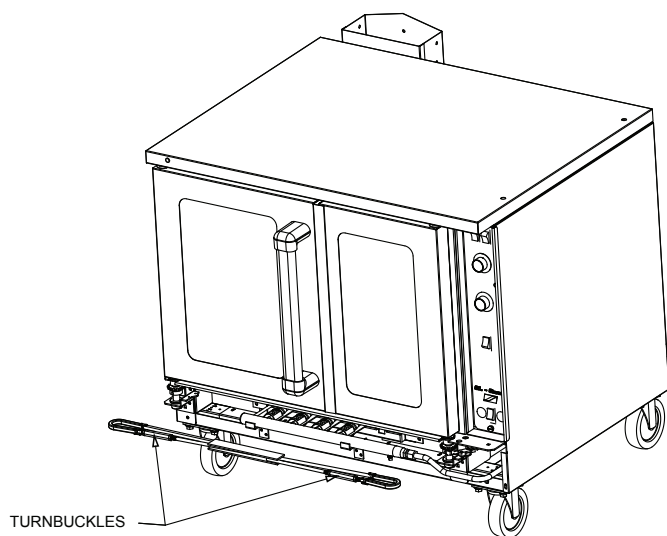

TEMPERATURE CONTROLLER (Standard-Control Models Only)

The calibration of the temperature controller should not be changed until sufficient experience with cooking results has definitely proved that the temperature controller is not maintaining proper oven temperatures. Before any recalibration is attempted, the oven temperature should be checked by the following procedure:

1. Remove all trays and pans from the oven.
2. Place a thermocouple or a reliable mercury oven-type thermometer at the center of the middle rack.
3. Turn the oven ON and set the temperature control knob to 400 °F.
4. The amber "heat on" light will go out when the oven temperature is reached.
5. Allow three cycles for the temperature to stabilize.
6. Read the thermocouple or thermometer immediately after the light goes out for the third time, and again immediately after it comes on the next time.
7. If the average of these readings varies by more than 10 °F from the dial setting, recalibrate by the following procedure.
Recalibration should be attempted only by a competent service technician.

Use the following procedure to recalibrate the oven:

1. Loosen the two set screws that secure the temperature-control knob to the temperature-control shaft.
2. Remove the knob from the shaft, being careful not to rotate the knob or shaft.
3. Replace the knob on the shaft so that the indicator mark on the knob points directly at the temperature that was measured at the center of the oven.
4. Re-check the oven calibration.

FAHRENHEIT OR CELSIUS DISPLAY (Cycle/Cook & Hold Models Only)

Ovens with Cycle/Cook & Hold controls can be configured to display temperatures using the Fahrenheit or the Celsius scales. To change the choice, change the position of the blue jumper "J3" on the rear of the control panel circuit board.

TROUBLESHOOTING

ADJUSTMENTS AND SERVICE WORK MAY BE PERFORMED ONLY BY A QUALIFIED TECHNICIAN WHO IS EXPERIENCED IN, AND KNOWLEDGEABLE WITH, THE OPERATION OF COMMERCIAL COOKING EQUIPMENT. HOWEVER, TO ASSURE YOUR CONFIDENCE, CONTACT YOUR AUTHORIZED SERVICE AGENCY FOR RELIABLE SERVICE, DEPENDABLE ADVICE OR OTHER ASSISTANCE, AND FOR GENUINE FACTORY PARTS.



Warranty will be void and the manufacturer is relieved of all liability if service work is performed by other than a qualified technician, or if other than genuine Southbend replacement parts are installed.

NOTICE

In case of problems in operation at initial installation, check type of gas and manifold pressure and compare with information listed on the serial plate. The serial plate is located inside the lower front panel.

PERFORMANCE STANDARD

The typical time for the oven to heat from 75 ° F to 350 ° F is 5 to 6 minutes for ovens using natural gas, and 7 to 8 minutes for ovens using propane.

The burners should come on when the actual oven temperature drops to 10 ° F below the temperature setting.

TROUBLESHOOTING GUIDE

The left column of the following table lists symptoms that indicate a problem, while the center and right columns list the possible causes and appropriate corrective action. Note that the recommendations of this table assume that the wiring connections are good. When checking a component, always check the wiring attached to the component as well.

Symptom	Possible Cause	Check or Replace
Oven will not hold correct temperature.	Temperature probe not working.	Resistance across temperature probe leads at room temperature (70°F) should be approximately 1096 ohms.
	Temperature control not calling for heat.	When heat is required, there should be continuity between terminals 6 and 7 on temperature control.
	Undersized gas supply line	Oven requires 3/4" ID gas line.
	Low gas pressure.	Oven requires 7" manifold water column pressure for natural gas, 11" for propane.
	Inadequate or improper ventilation.	Check ventilation hood. Verify draw and make up air adjustment.
	Out of calibration.	Recalibrate temperature
Hot surface ignitor glows red but burners do not come on when thermostat calls for heat (cooking light is on).	No power to gas valve.	Check for 24V from ignition box to gas valve.
	Faulty main gas solenoid.	Replace gas valve.
	Faulty ignition module.	Replace ignition module.
	Manual shutoff valve closed	Open all shut-off valve.
	Manual valve on gas valve turned off.	Open manual valve on gas valve.
	Hot surface ignitor not in front of rear end of burner.	Re-position hot surface ignitor to be in front of rear end of burner.
Hot surface ignitor does not glow red.	No power to ignitor.	Check that voltage from ignitor module to ignitor is 24V. Ignitor draws approximately 3.35 amps at start as it heats up resistance goes down. Gas valve opens approximately 1.8 amps.
	Ignitor broken or cracked.	Should read continuity between leads on ignitor.
	No power to ignition module.	Should be 24V from transformer to ignition module.
	Check power to transformer.	Should be voltage stamped on serial plate. Check between 3 and 6 on terminal strip.
	Check blower motor. Motor should turn when power switch is turned on and temperature control calls for heat.	Motor has centrifugal switch. Motor must be turning before ignition circuit is energized. Power for motors come through contactors. Check contactors (one for high speed, one for low speed).
	Temperature control does not call for heat	Must read continuity between 6 and 7 on temperature control when calling for heat.
	No power out of power switch..	Check that unit power cord is plugged into power supply. Check switch for continuity when switch is closed.
First burner next to ignitor lights, but flame will not carry across to other burners	Burners not aligned.	Check burner carry over wings for proper mating.
	Burner and orifice out of alignment.	Orifice must inject gas down center of burner.
	Gas pressure to low.	Oven requires 7" manifold water column pressure for natural gas, 11" for propane.
	Burner orifices clogged.	Make sure burner orifices are clear.

Table continues on next page.

Symptom	Possible Cause	Check or Replace
Burners light but go out within a few seconds. (Ignitor will glow approximately 4 seconds. If burner does not ignite, ignition module will try 3 times and then lock out.)	Bad flame switch.	Check in series on micro amps. Minimum is 0.75 amps, no maximum.
	Bad gas valve.heat.	Check gas valve. Should be 24 volts from ignition module on wires 46 and 47.
Blower motor will not come on.	No incoming electric power.	Check incoming power.
	Loose wire connections.	Check wire connections.
	Bad contactors.	Contactors pull in and supply power to motor. Verify contactor pulling in.
	Motor bad.	If power is being supplied but motor will not turn, replace motor.
	Shut down switch.	All power except for motor supply come through shut down switch. Check for continuity.

BLOWER WHEEL REPLACEMENT

To replace the blower wheel, do the following:

1. Remove racks and rack guides.
2. Remove rear air baffle in front of blower wheel.
3. Loosen the two square heads on blower wheel hub.
4. Pull blower wheel from motor shaft. If blower wheel is difficult to pull off, use puller disk (available from Southbend Technical Service Department as part number [1179100](#)).

CONTROL PANEL ACCESS AND SHUT-OFF SWITCH

To access the control panel components, remove the two thumbs screws at the top and bottom of the control panel and slide the control panel out (see 1ST picture on next page). A wiring diagram for the oven is located on the side of the control panel assembly. **When the control panel is slid out, all power to the control panel is cut off by a shut down switch that is located directly inside the opening and below the control panel** (see 2ND picture on next page). To re-energize the controls for troubleshooting, pull the plunger on the shut down switch up.

To fully remove Control Panel, disconnect temp probe wires and harness connectors prior to pulling up on slide release levers and removing.

Figure 30

Accessing Control Panel Components

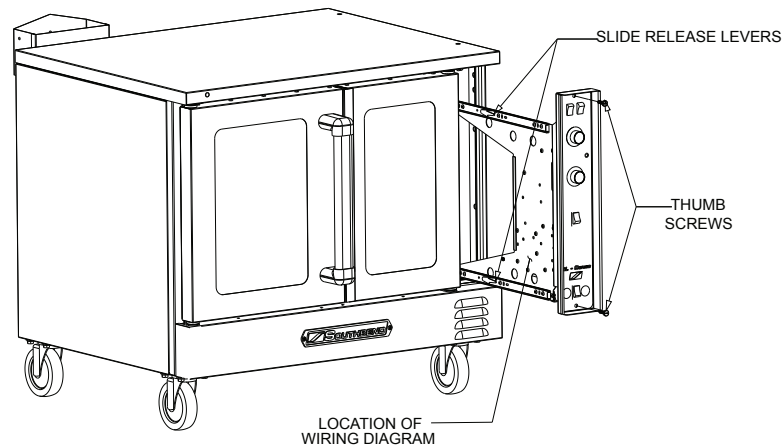
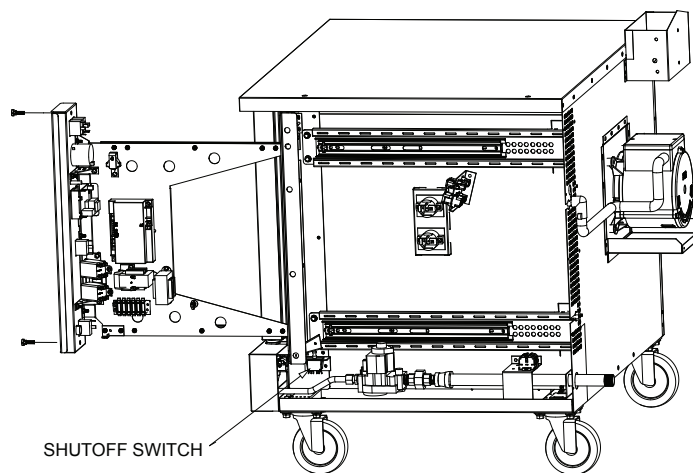

Figure 31

Accessing Control Panel Components



WIRING DIAGRAMS

A wiring diagram is located on the side of the control panel assembly. Wiring diagrams also appear on the following pages of this manual. Which wiring diagram is appropriate depends on the voltage and type of controls.

Index of Wiring Diagrams

Page Number	Voltage and Type of Controls
Page 50	120 Volt Models with Standard Controls
Page 51	208-240 Volt Models with Standard Controls
Page 52	120 Volt Models with Cycle/Cook & Hold Controls
Page 53	208-240 Volt Models with Cycle/Cook & Hold Controls
Page 54	120 Volt Models with Touchscreen Controls
Page 55	208-240 Volt Models with Touchscreen Controls

Figure 32

Wiring Diagram for 120 Volt Models with Standard Controls

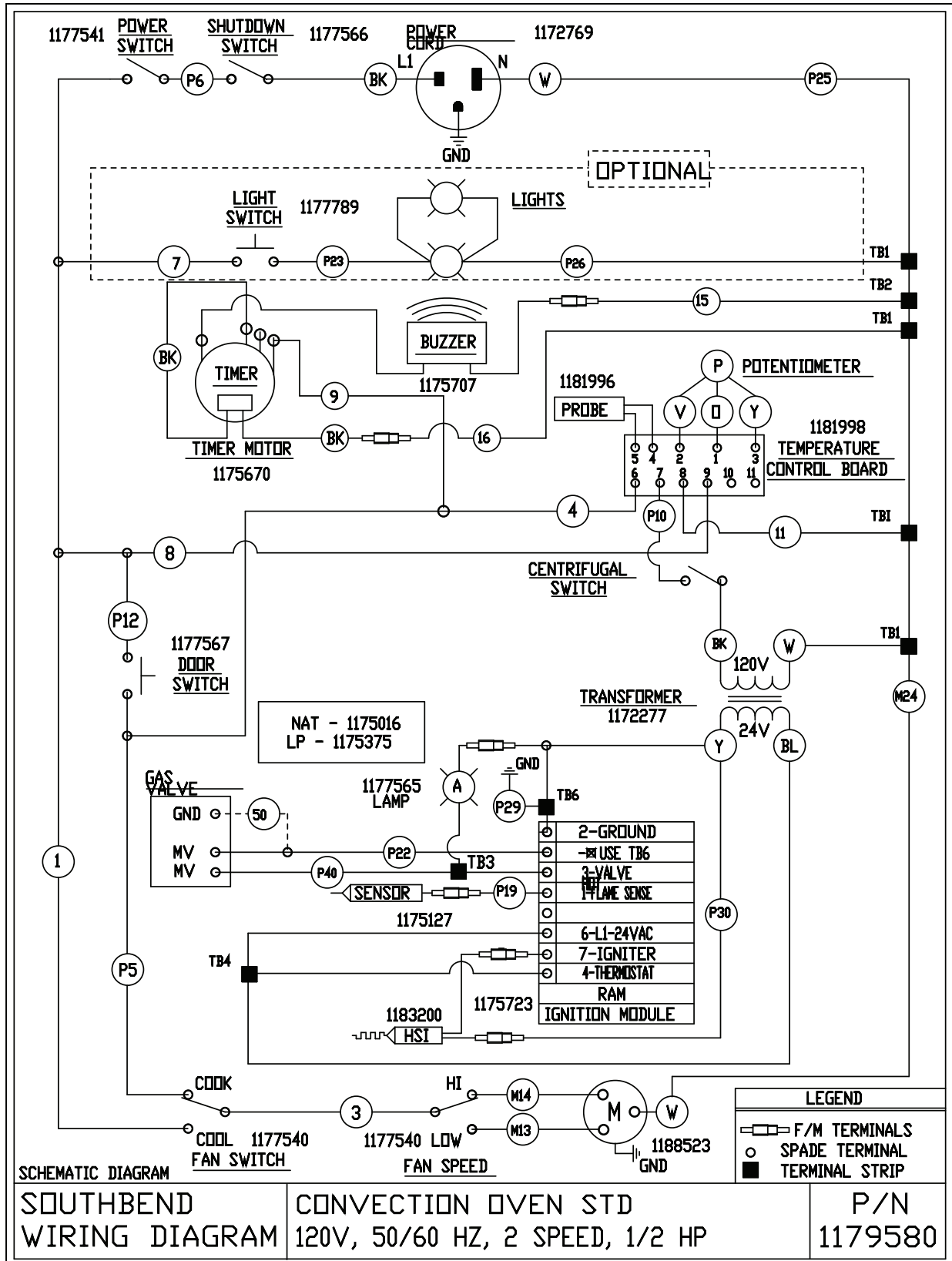

Figure 33

Wiring Diagram for 208-240 Volt Models with Standard Controls

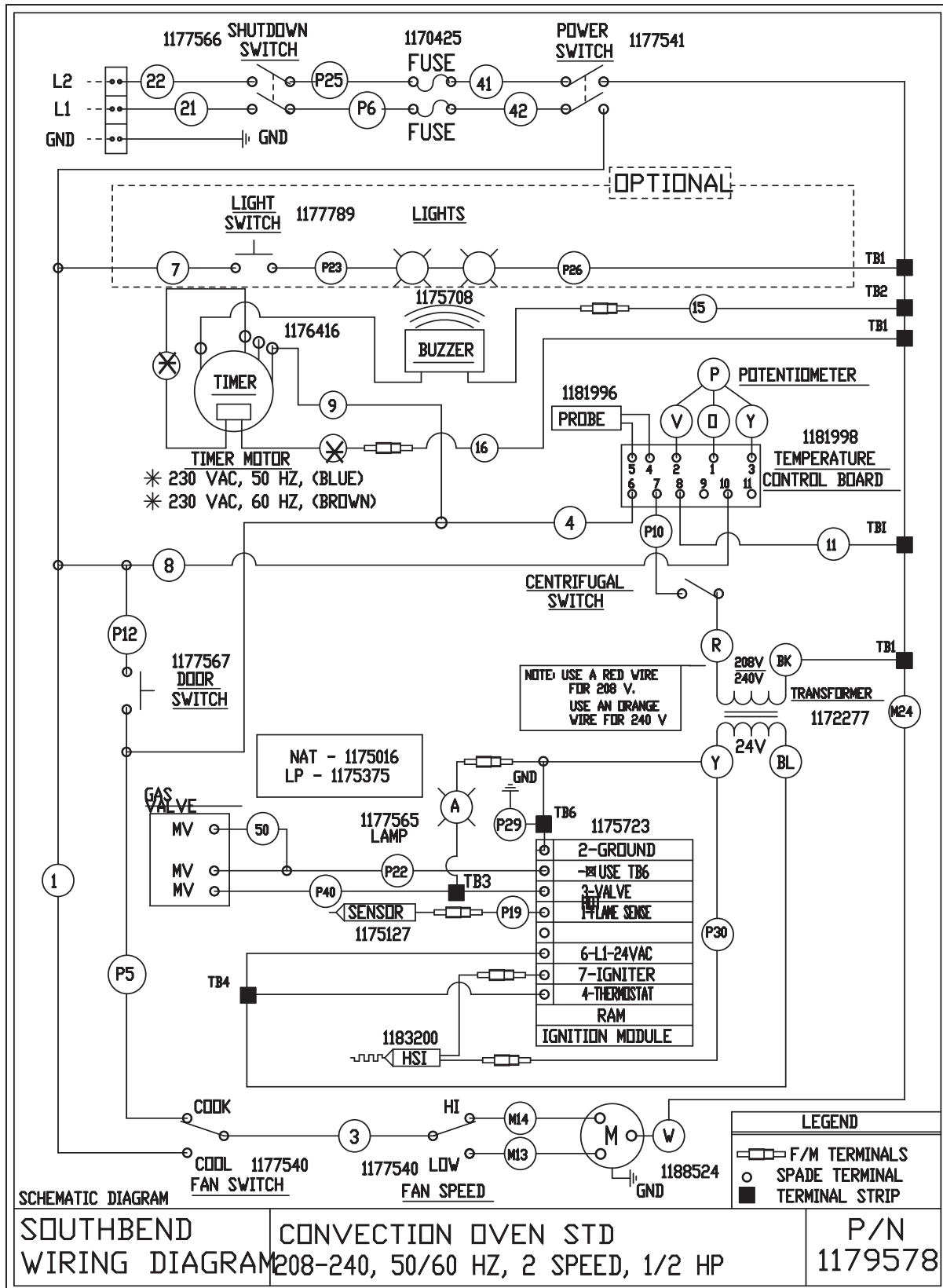

Figure 34

Wiring Diagram for 120 Volt Models with Cycle/Cook and Hold Controls

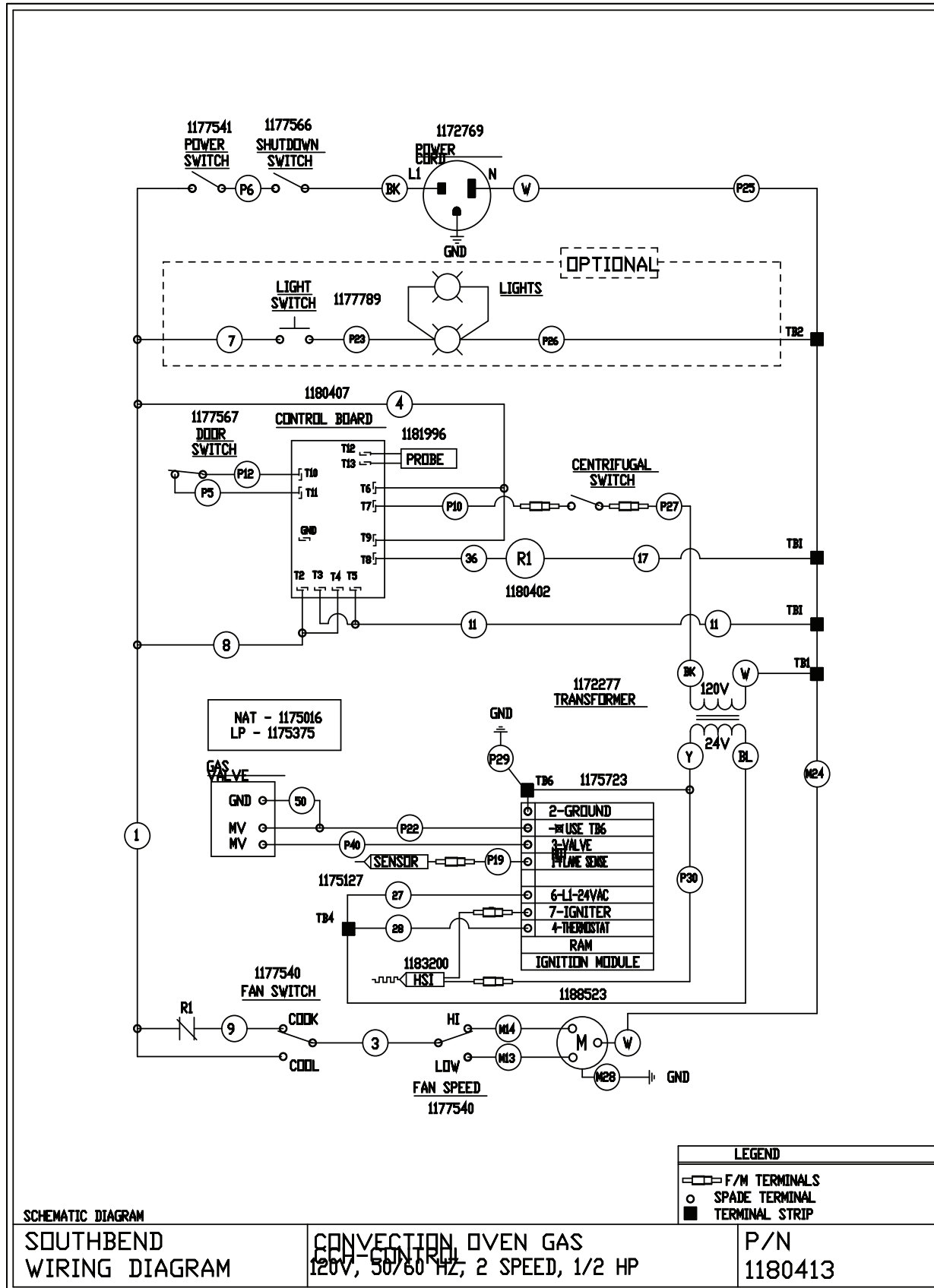

Figure 35

Wiring Diagram for 208-240 Volt Models with Cycle/Cook and Hold Control

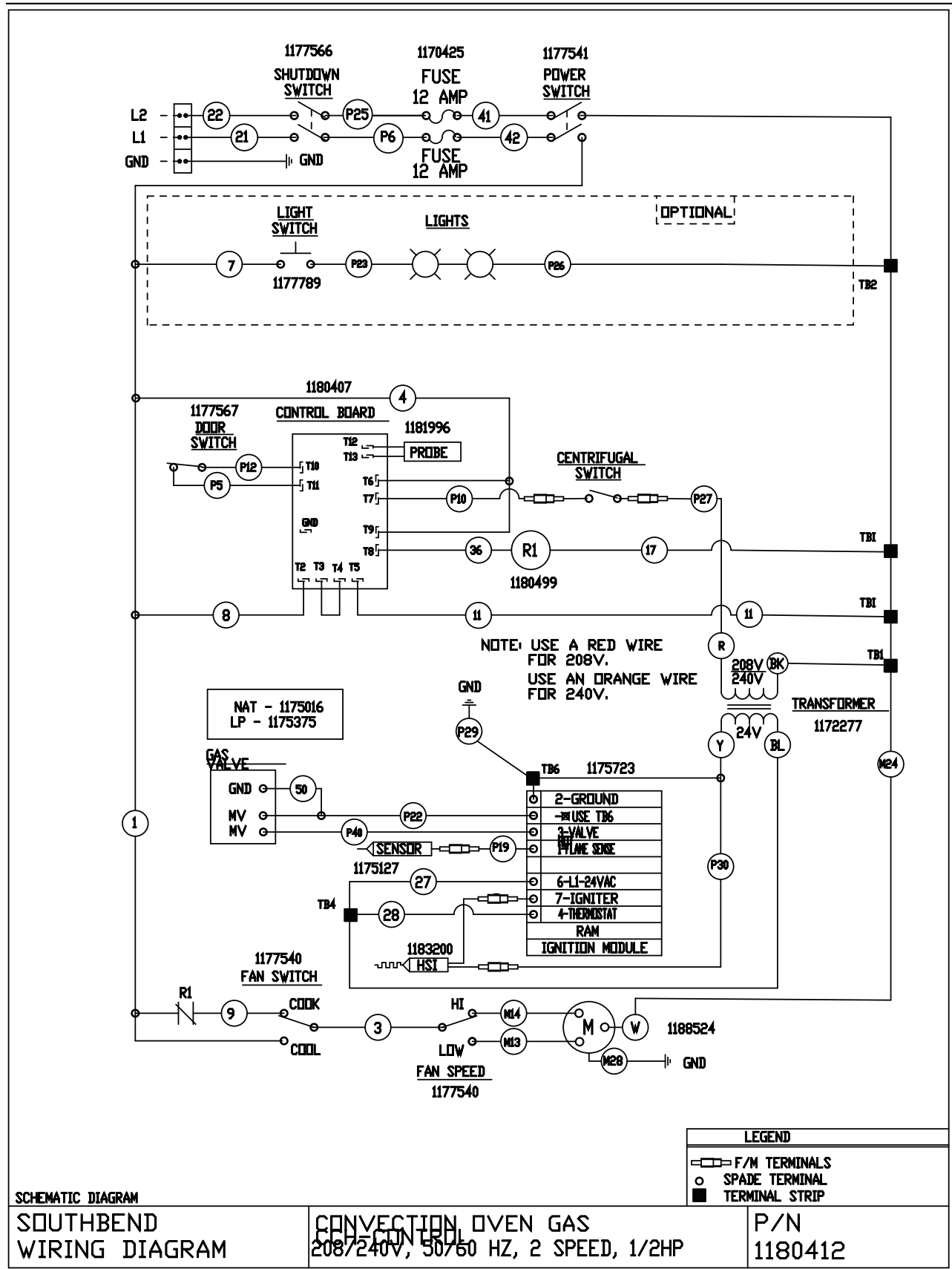
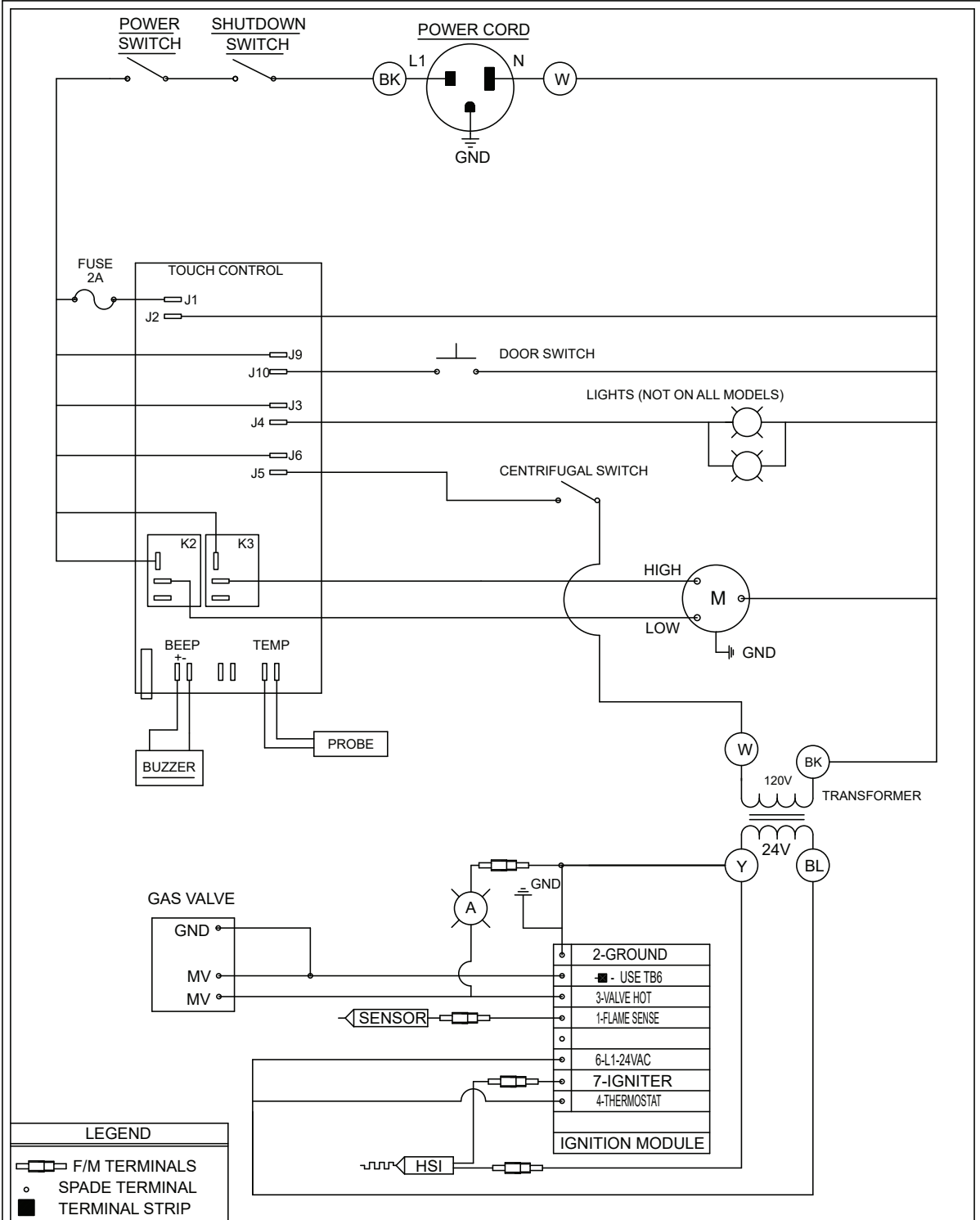

Figure 36

Wiring Diagram for 120 Volt Models with Touchscreen Controls



<p>SOUTHBEND WIRING DIAGRAM</p>	<p>SCHEMATIC, TOUCHSCREEN 120V GAS</p>	<p>REV -</p>	<p>P/N 1407914</p>
--	--	------------------	------------------------

Figure 37

Wiring Diagram for 208-240 Volt Models with Touchscreen Controls

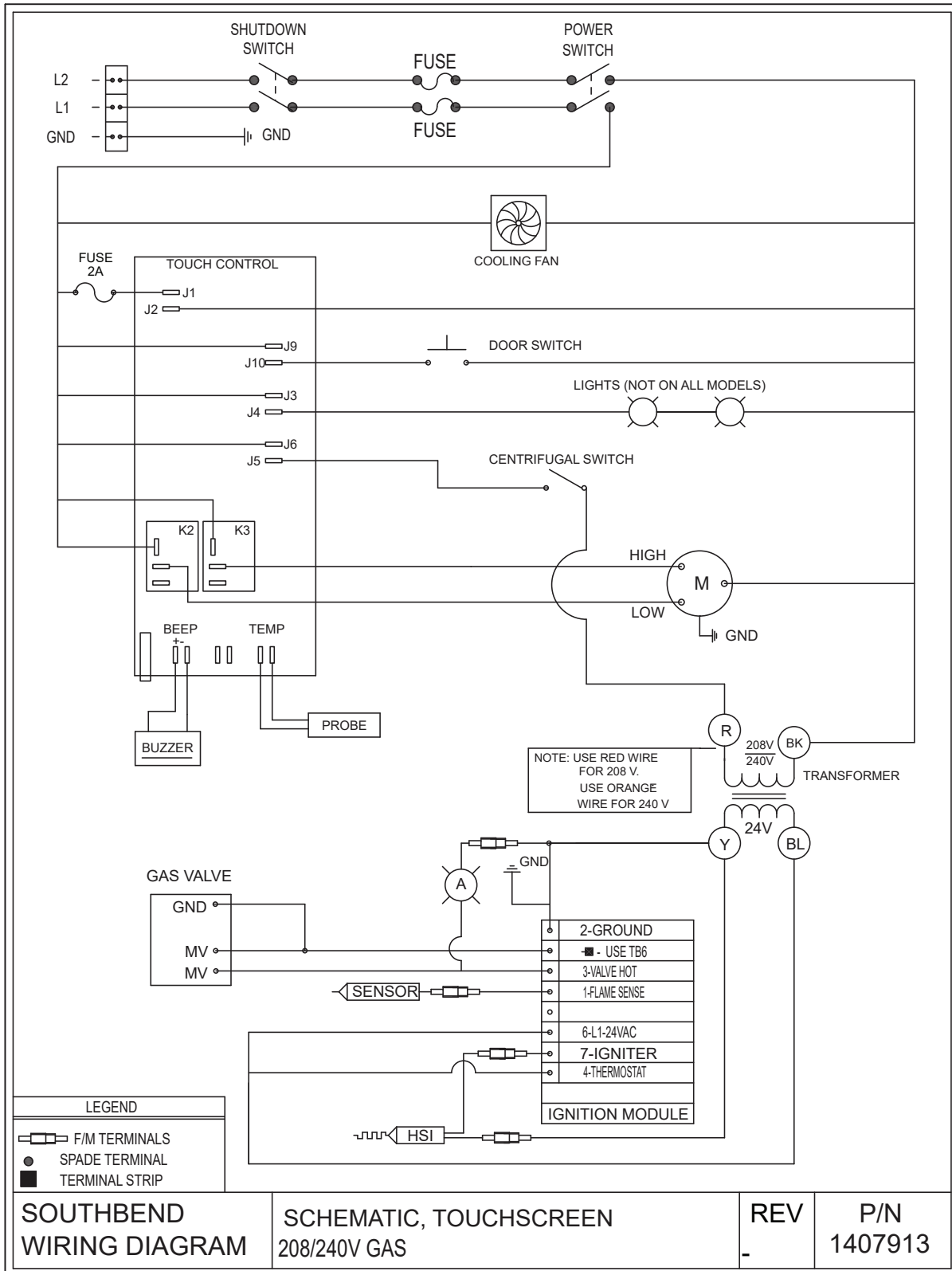

G-SERIES, SL-SERIES & B-SERIES GAS CONVECTION OVENS



A product with the Southbend name incorporates the best in durability and low maintenance. We all recognize, however, that replacement parts and occasional professional service may be necessary to extend the useful life of this appliance. When service is needed, contact a Southbend Authorized Service Agency, or your dealer. To avoid confusion, always refer to the model number, serial number, and type of your appliance.



SOUTHBEND
 **MIDDLEBY** A Middleby Company
 1100 Old Honeycutt Road Fuquay-Varina, North Carolina 27526 USA
www.southbendnc.com