

Engineered to Perform, Built to Last.
SOUTHBEND
Installation & Operations Manual

IMPORTANT FOR FUTURE REFERENCE
Please complete this information and retain
this manual for the life of the equipment
Model #: _____
Serial #: _____
Date Purchased: _____

Oven Range

Model SE36

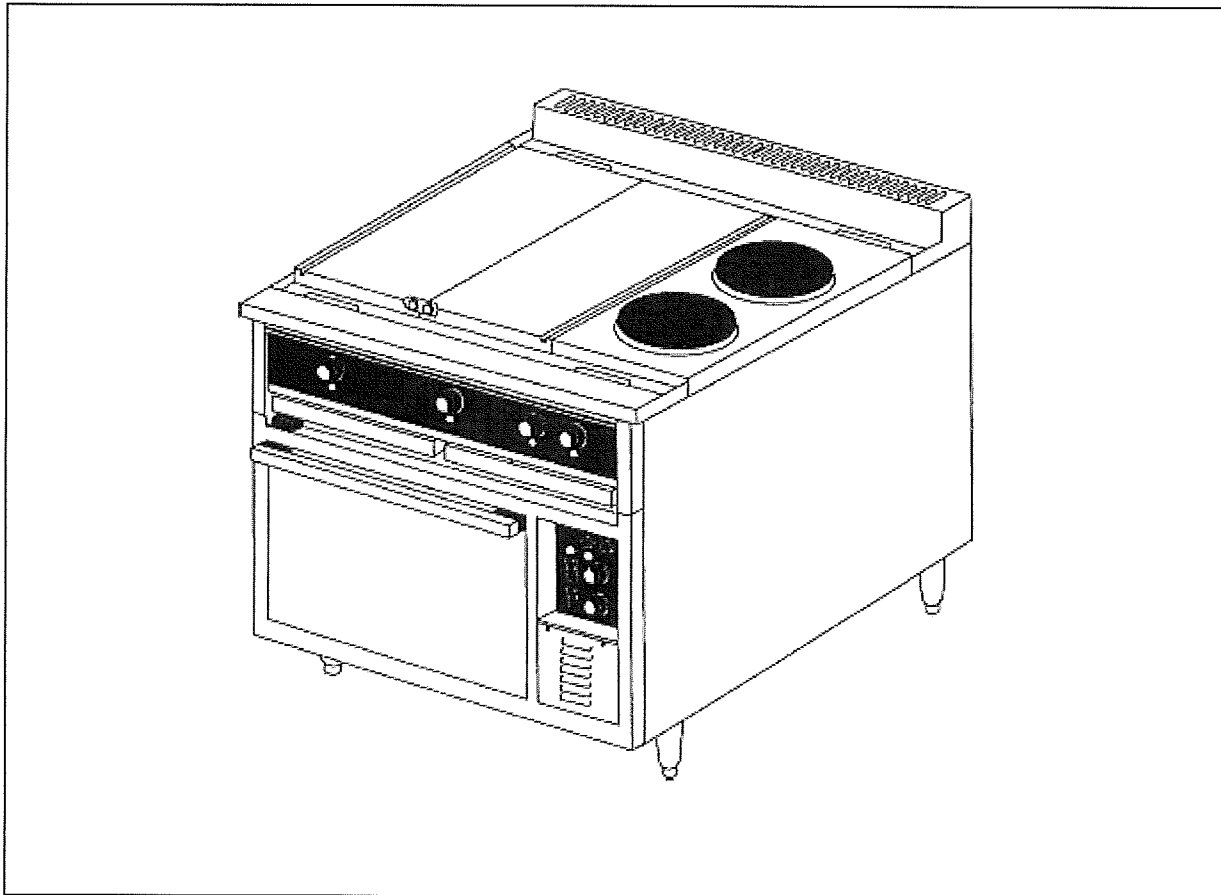

This page intentionally left blank

IN CASE OF FIRE

De-energize oven range at disconnect switch. This will cut off power to the heating elements allowing oven range to cool. This reduces the temperature making it easier to stop the fire.

CAUTION:

Do not attempt to fight a grease fire by pointing the nozzle of the fire extinguisher directly on the burning grease. The force will cause the burning grease to be sprayed to adjoining equipment making it difficult to contain the fire. Use a fire extinguisher filled with CO₂ only which is for liquids and oils and suitable for electric powered equipment.

RETAIN THIS MANUAL FOR FUTURE REFERENCE

This manual provides detailed information for installation and operation of your new oven range. It also contains some information to assist the operator in diagnosing problems in the event of a malfunction. This manual is an important tool for the operator and should be kept readily available.

**FOR YOUR SAFETY
DO NOT STORE OR USE GASOLINE
OR OTHER FLAMMABLE VAPORS OR LIQUIDS
IN THE VICINITY OF THIS OR ANY OTHER APPLIANCE**

NOTICE

Using any parts other than genuine Southbend factory supplied parts relieves the manufacturer of all liability.

NOTICE

Southbend (Manufacturer) reserves the right to change specifications and product design without notice. Such revisions do not entitle the buyer to corresponding changes, improvements, additions or replacements for previously purchased equipment.

TABLE OF CONTENTS

SECTION 1	
DESCRIPTION	1
A. Oven Base	1
B. Range	2
C. Specifications	7
SECTION 2	
INSTALLATION	9
A. Inspect For Shipping Damage	9
B. Installation of Oven Range	10
C. Assembling the Oven and Range Modules	11
D. Electrical Connection	11
E. Initially Cleaning the Griddle and/or Hot Plates	11
F. Testing the Installation	12
G. Marine Oven Range Installation On Curb	12
H. Dimension Drawings	13-14
SECTION 3	
OPERATION	15
I. Component Function and Location	15
II. Control Functions and Locations	16
III. Operation	19
IV. Time and Temperature Charts	24
SECTION 4	
PARTS LIST	29
Overall Drawing Parts List	30
Convection Oven	32
Deck Oven	34
Vents and Marine Rails	36
SECTION 5	
SCHEMATICS	39
Electrical Schematics & Wiring	39-59

SECTION 1

DESCRIPTION

I. Description

Southbend Model SE36 electric oven ranges are rated heavy duty for commercial use. The oven range consists of a range top fastened to an oven base. There is a marine kit available which qualify it for shipboard use. The marine features are an oven door latch, grease tray latch, bolt-down legs, range top adjustable sea rails and a grab bar across the front.

A. OVEN BASE

The oven base can be either a deck oven or a convection oven.

1. Deck Oven ("D" in Model #, example SE36D-HHH)

The deck oven base has an aluminized steel inner lining, removable deck of rigidized steel, vent with damper and fully gasketed landing shelf type stainless steel lined door. The oven is insulated on all sides and is equipped with one slide-in rack. Heating is accomplished with top and bottom formed tubular heating elements which are each controlled by a 3-heat (low, medium and high) switch. The deck oven has a thermostatic control with a temperature range of 200°F to 550°F (93°C to 287°C). The oven will preheat to 450°F (232°C) in 20 minutes.

2. Convection Oven ("A" in Model #, example SE36A-HHH)

The convection oven has removable stainless steel oven liners, vent with damper and fully gasketed landing shelf type stainless steel lined door. The oven is insulated on all sides. Removable rack supports can accommodate six racks. The heating element is enclosed in the side of the oven cavity and encircles the oven blower fan. The convection oven has a thermostatic control with a temperature range of 150°F to 450°F (65°C to 232°C). The oven will preheat to 450°F (232°C) in 15 minutes.

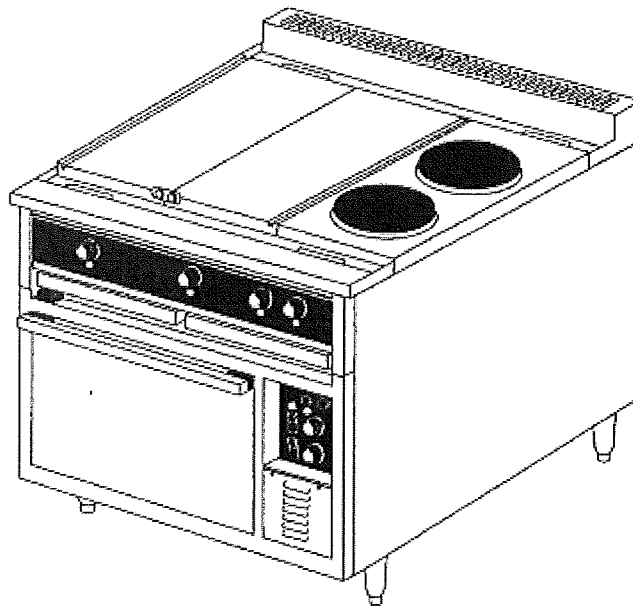

Figure 1-1

SECTION 1 - DESCRIPTION

B. RANGE

The range can consist of up to 3 different components and the components can be configured in six ways. Troughs with drip chutes are located at the front and rear for drainage into two wide drawer type receptacles.

1. Range Components Descriptions

- a. **Griddle** for griddling. The griddle can be either 24" x 24" or 24" x 36". The griddles are controlled by thermostats. The 24" x 24" griddle has a thermostat control for each of two 12" x 24" zones and the 24" x 36" griddle has a thermostat control for each of four 9" x 24" zones. The griddles zones have a temperature range of 150°F to 450°F (65°C to 232°C) and will preheat to 400°F (204°C) in 12 minutes.

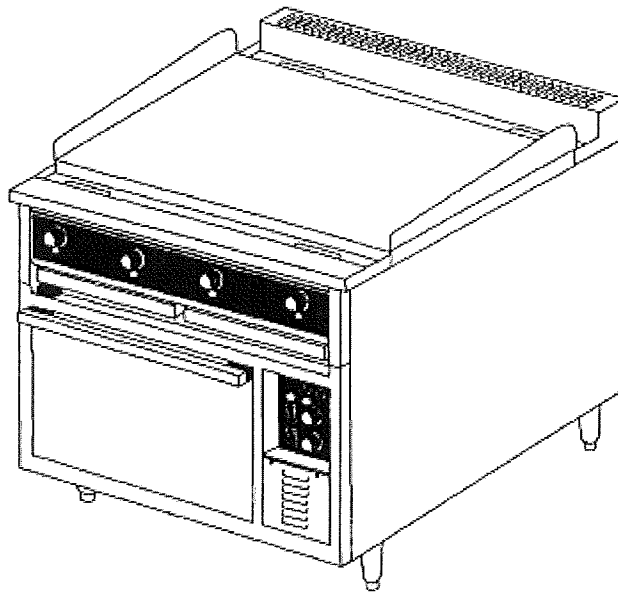

**Figure 1-2
Griddle**

SECTION 1 - DESCRIPTION

- b. 12" x 24" **Hot Plate** for stock pot cooking (Not recommended for griddling). The hot plates are thermostatically controlled and have a temperature range of 250°F to 850°F (121°C to 454°C) and will preheat to 400°F (204°C) in 12 minutes.

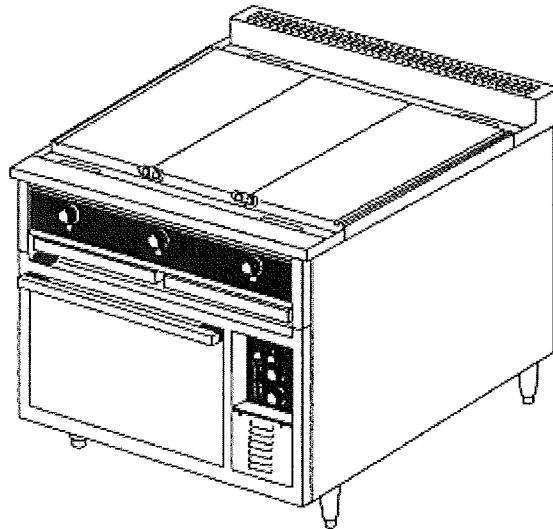

Figure 1-3
Hot Plate

- c. **Round Hot Plate** for stock pot cooking. The twin hot plates have a 9" diameter and are controlled by 6 position heat switch, ranging from Hi to Low heat settings.

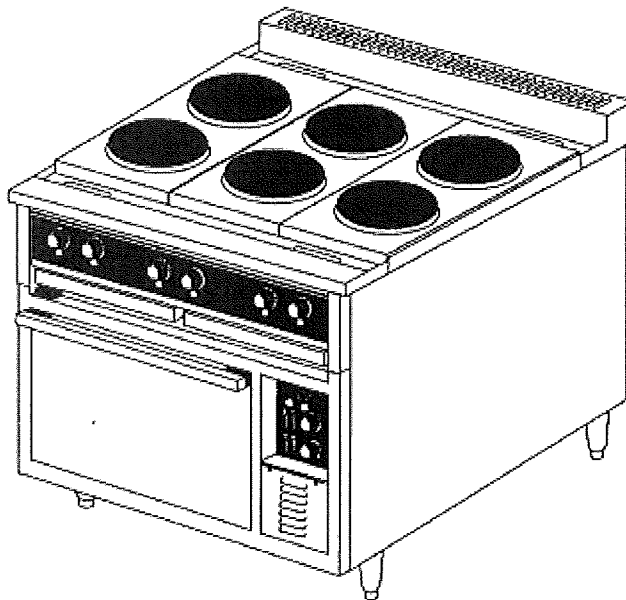

Figure 1-4
Round Hot Plate

SECTION 1 - DESCRIPTION

2. Range Top Configurations

- a. **All Purpose Top SE36D/A-HHH.** The all purpose top consists of three 12" x 24" hot plates. The all purpose top is not recommended for griddling.

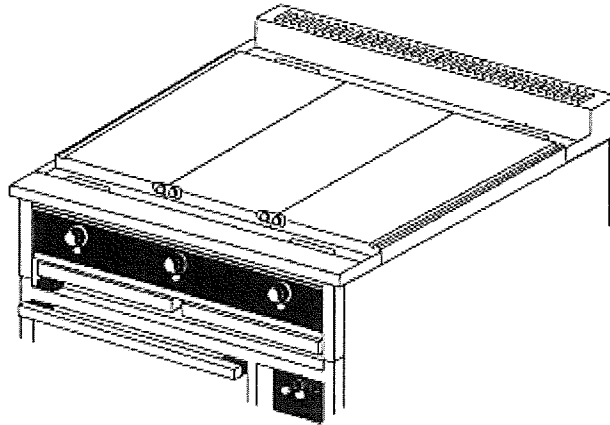

Figure 1-5
All Purpose Top

- b. **Multi-Purpose Top SE36D/A-HHB.** The multi-purpose top consists of two 12" x 24" hot plates and two 9" round hot plates. The multi-purpose top is not recommended for griddling.

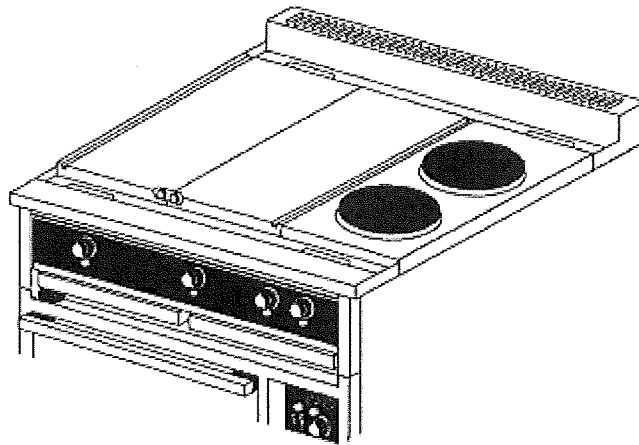
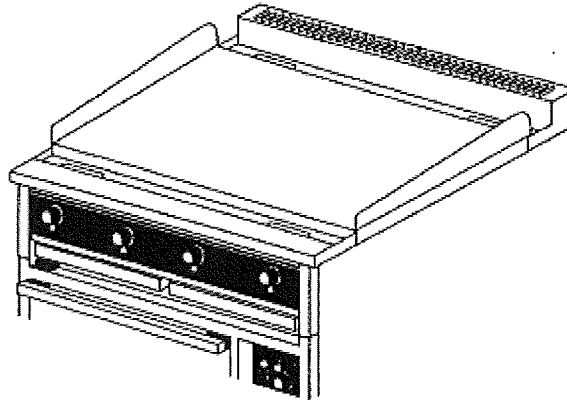

Figure 1-6
Multi-Purpose Top

SECTION 1 - DESCRIPTION

c. Griddle Top SE36D/A-TTT. The griddle top consists of one 36" x 24" griddle plate.



**Figure 1-7
Griddle Top**

d. Round Hot Plate Top SE36D/A-BBB. The round hot plate top consists of six 9" hot plates.

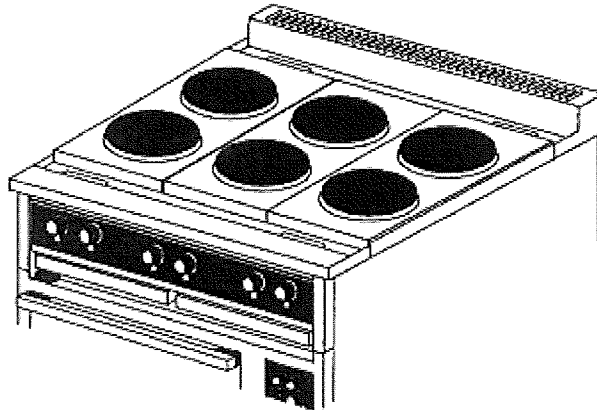

**Figure 1-8
Round Hot Plate**

SECTION 1 - DESCRIPTION

- e. **Griddle/Round Hot Plate Top SE36D/A-TTB.** The griddle/round hot plate top consists of one 24" x 24" griddle and two 9" round hot plates.

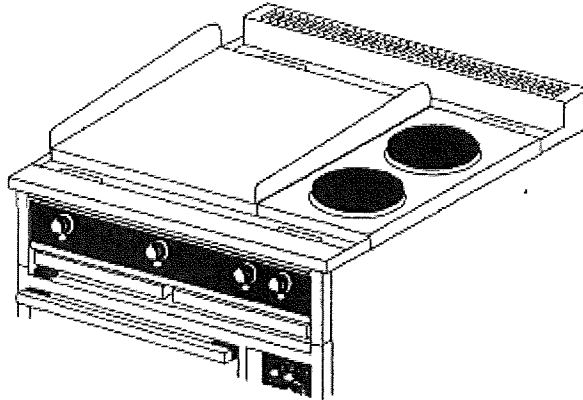

Figure 1-9
Griddle/Round Hot Plate

- f. **Griddle/12" x 24" Hot Plate Top SE36D/A-TTH.** The griddle/12" x 24" hot plate top consists of one 24" x 24" griddle and one 12" x 24" hot plate.

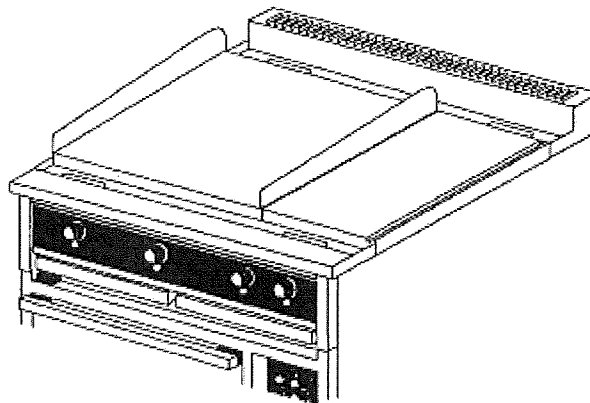

Figure 1-10
Griddle/Hot Plate

C. SPECIFICATIONS

OVEN RANGE MODELS	RH36	MH36
Overall Dimensions:		
Width	36"(91.5 cm)	36"(91.5 cm)
Depth	38-3/4"(98.4 cm)	40"(101.6 cm)
Height	38-1/4"(97 cm)	38-1/4"(97 cm)
Net Weight		
Model SE36A-HHH	669 lb (268 kg)	669 lb (268 kg)
Model SE36A-HHB	515 lb (234 kg)	515 lb (234 kg)
Model SE36A-TTT	588 lb (267 kg)	588 lb (267 kg)
Model SE36A-BBB	455 lb (207 kg)	455 lb (207 kg)
Model SE36A-TTB	515 lb (234 kg)	515 lb (234 kg)
Model SE36A-TTH	545 lb (247 kg)	545 lb (247 kg)
Model SE36D-HHH	669 lb (268 kg)	669 lb (268 kg)
Model SE36D-HHB	515 lb (234 kg)	515 lb (234 kg)
Model SE36D-TTT	588 lb (267 kg)	588 lb (267 kg)
Model SE36D-BBB	497 lb (226 kg)	497 lb (226 kg)
Model SE36D-TTB	515 lb (234 kg)	515 lb (234 kg)
Model SE36D-TTH	545 lb (247 kg)	545 lb (247 kg)
Shipping Weight		
Model SE36A-HHH	610 lb (277 kg)	610 lb (277 kg)
Model SE36A-HHB	570 lb (259 kg)	570 lb (259 kg)
Model SE36A-TTT	610 lb (277 kg)	610 lb (277 kg)
Model SE36A-BBB	485 lb (220 kg)	485 lb (220 kg)
Model SE36A-TTB	570 lb (259 kg)	570 lb (259 kg)
Model SE36A-TTH	545 lb (247 kg)	545 lb (247 kg)
Model SE36D-HHH	669 lb (268 kg)	669 lb (268 kg)
Model SE36D-HHB	515 lb (234 kg)	515 lb (234 kg)
Model SE36D-TTT	588 lb (267 kg)	588 lb (267 kg)
Model SE36D-BBB	497 lb (226 kg)	497 lb (226 kg)
Model SE36D-TTB	515 lb (234 kg)	515 lb (234 kg)
Model SE36D-TTH	545 lb (247 kg)	545 lb (247 kg)
Construction	-----Welded Angle Iron-----	
Finish:	-----Stainless Steel Front Sides and Top----- -----Aluminized Steel Back-----	
Electrical Specifications	Refer to Section 5	

NOTICE

Southbend (Manufacturer) reserves the right to change specifications and product design without notice. Such revisions do not entitle the buyer to corresponding changes, improvements, additions or replacements for previously purchased equipment.

SECTION 1 - DESCRIPTION

NOTES

SECTION 2

INSTALLATION

A. Inspect for Shipping Damage

All shipping containers should be examined for damage before and during unloading. This equipment was carefully inspected and packaged at the factory. The freight carrier has assumed responsibility for its safe transit and delivery. If equipment is received in damaged condition, either apparent or concealed, a claim must be made with the delivering carrier.

1. Apparent Damage or Loss - If damage or loss is apparent it must be noted on the freight bill or express receipt at the time of delivery, and it must be signed by the carrier's agent (driver). If this is not done, the carrier may refuse the claim. The carrier will supply the necessary claim forms.

2. Concealed Damage or Loss - If damage or loss is NOT apparent until after equipment is unpacked, a request for inspection of concealed damage must be made with carrier within 15 days. The carrier will make an inspection and will supply necessary claim forms. Be certain to retain all contents plus external and internal packaging materials for inspection.

SECTION 2 - INSTALLATION

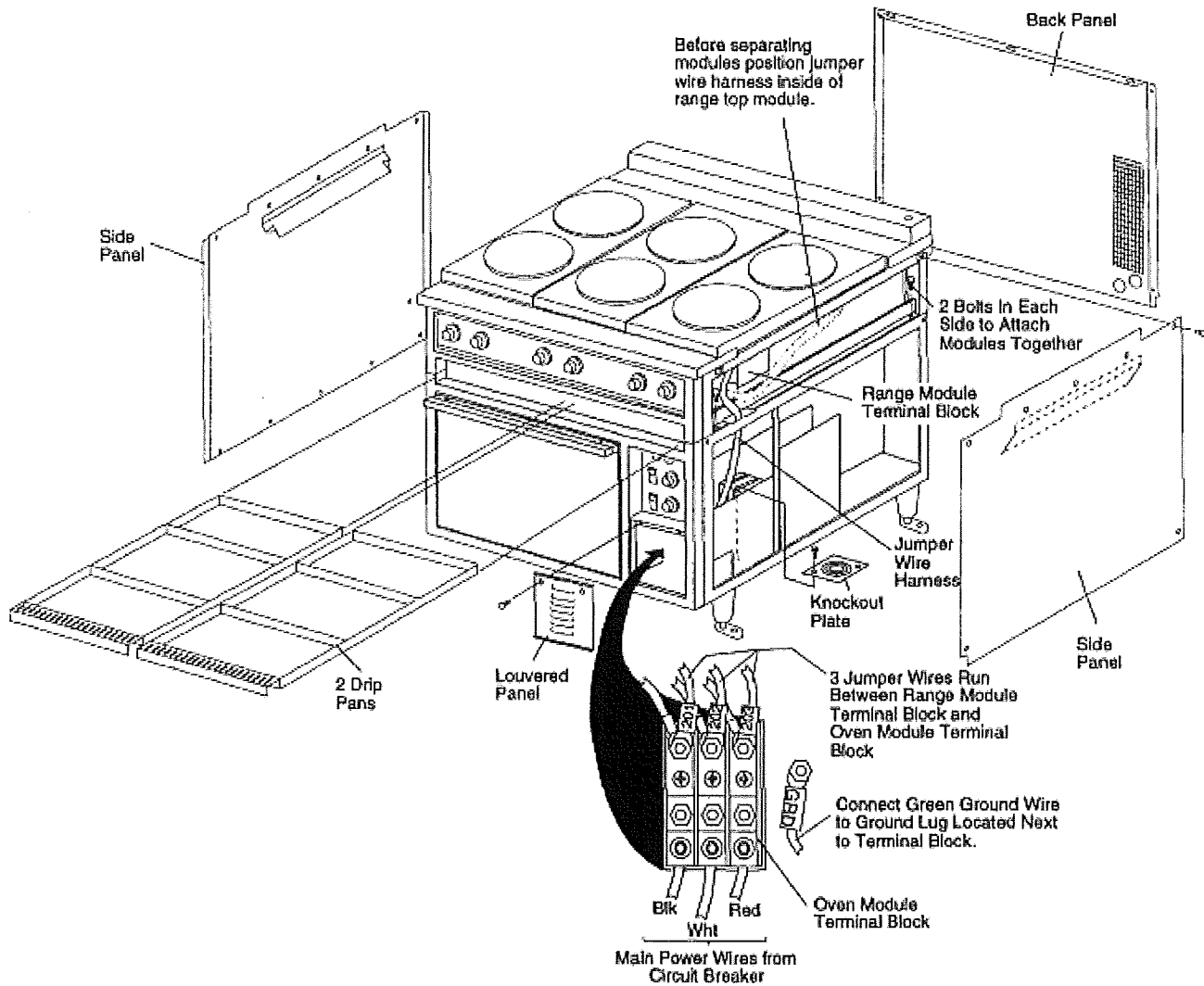

Figure 2-1

B. Installation of Oven Range

The oven range can be shipped assembled or the range top module and the oven module can be packed in separate cartons. If the oven range is shipped assembled simply remove the metal banding straps and packing materials and move it to the permanent location.

If the ovenrange is packed in two separate cartons and must be moved through a narrow passage follow the Pre-Installation Instructions located on the outside of the carton. If the oven range does not have to be moved through a narrow doorway then simply remove the metal banding straps and packing materials and move each carton to the permanent location. Use the following procedure to assemble the range top and oven modules.

SECTION 2 - INSTALLATION

C. Assembling (Stacking) the Oven Module and Range Module.

1. Move the range top module and the oven module to the area of their permanent location as directed in the previous Paragraph "B" or the Pre-Installation Instructions on the outside of the shipping carton.
2. Remove the following (refer to Figure 2-1):
 - Two drip pans
 - Two side panels
 - Back cover
 - Front louvered panel located below control panel
3. Place range top module in position on oven module.
4. Attach range top to oven using two 5/16" hex bolts on each side of oven (4 bolts total, furnished). Refer to Figure 2-1.
5. Thread jumper wire harness from range top through oven base frame opening and connect wires marked 201, 202 and 203 to terminal block as shown in Figure 2-1.
6. Remove all remaining packing materials.
7. On Marine Oven Ranges bolt the oven range to the floor/deck using the leg brackets.

D. Electrical Connection

1. Remove the right side panel and the front louvered panel located below the control panel if they have not already been removed.
2. Remove knockout plate located below terminal block on oven floor as shown in Figure 2-1. Knockout desired hole in knockout plate. Reassemble knockout plate to floor of oven.
3. Connect main power wires from circuit breaker to terminal block as shown in Figure 2-1.
4. Reinstall all panels and drip pans that were removed.

E. Initially Clean the Griddle and/or 12" x 24" Hot Plate(s)

1. Remove the rust preventive material from the surface with a non-flammable grease solvent.
2. Wash the surface with warm water and a mild detergent.
3. Rinse with a damp cloth and wipe dry.
4. Griddle must then be seasoned immediately. Refer to Section 3, Operation, for procedure to follow.

SECTION 2 - INSTALLATION

F. Testing the Installation

1. Turn all range and oven controls to the OFF position.
2. Turn main power disconnect switch to ON.
3. Check range top components by turning one control on at a time starting at the left side of the control panel. Check that the component is starting to heat and then turn it off.
4. Check the oven controls.
 - a. Deck oven - Set thermostat control at 300°F (149°C). Turn both the upper and lower heating element switches to LOW. Check that both the upper and lower elements are starting to heat and then turn them to OFF.
 - b. Convection oven - Set thermostat control to 300°F (149°C). Push fan switch LOW position. Turn oven power switch ON. After a few minutes open oven door and check for heat. If oven is heating turn all controls to OFF.

G. Marine Oven Range Installation on Curb

1. Installation of Oven Range on metal curb (shipped separately)
 - a. Bolt or weld base flange of metal curb (R/N33669) to floor of ship. See figure 2-2.
 - b. Position oven range on curb as shown in Figure 2-3.
 - c. Remove oven side covers and use existing mounting holes to bolt oven range to top flange of curb.
2. Installation of Oven Range on existing curb.
 - a. Existing curb must be ventilated as shown on metal curb in Figure 2-3. The opening for circulation must equal 8 square ft.(0.74 square meters)
 - b. Remove oven side covers and use existing mounting holes to bolt oven range to top of curb.

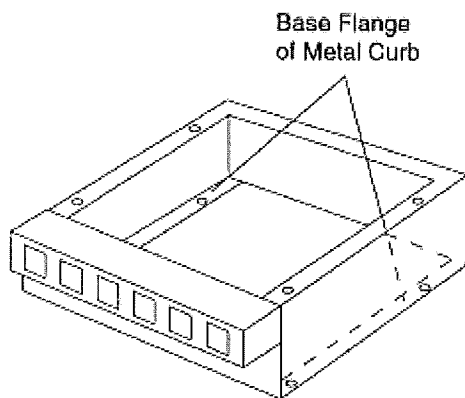

Fig. 2-2
Metal curb

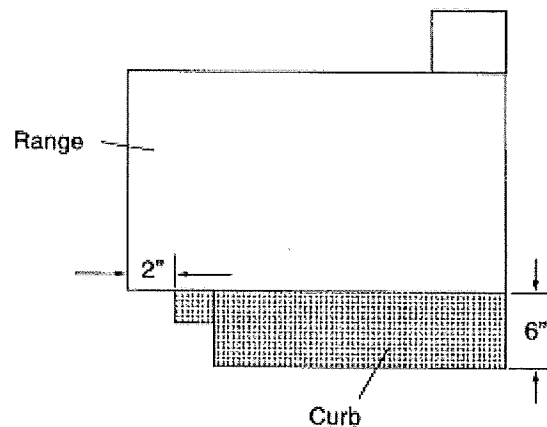

Fig. 2-3
Oven range on curb

H. Dimension Drawings

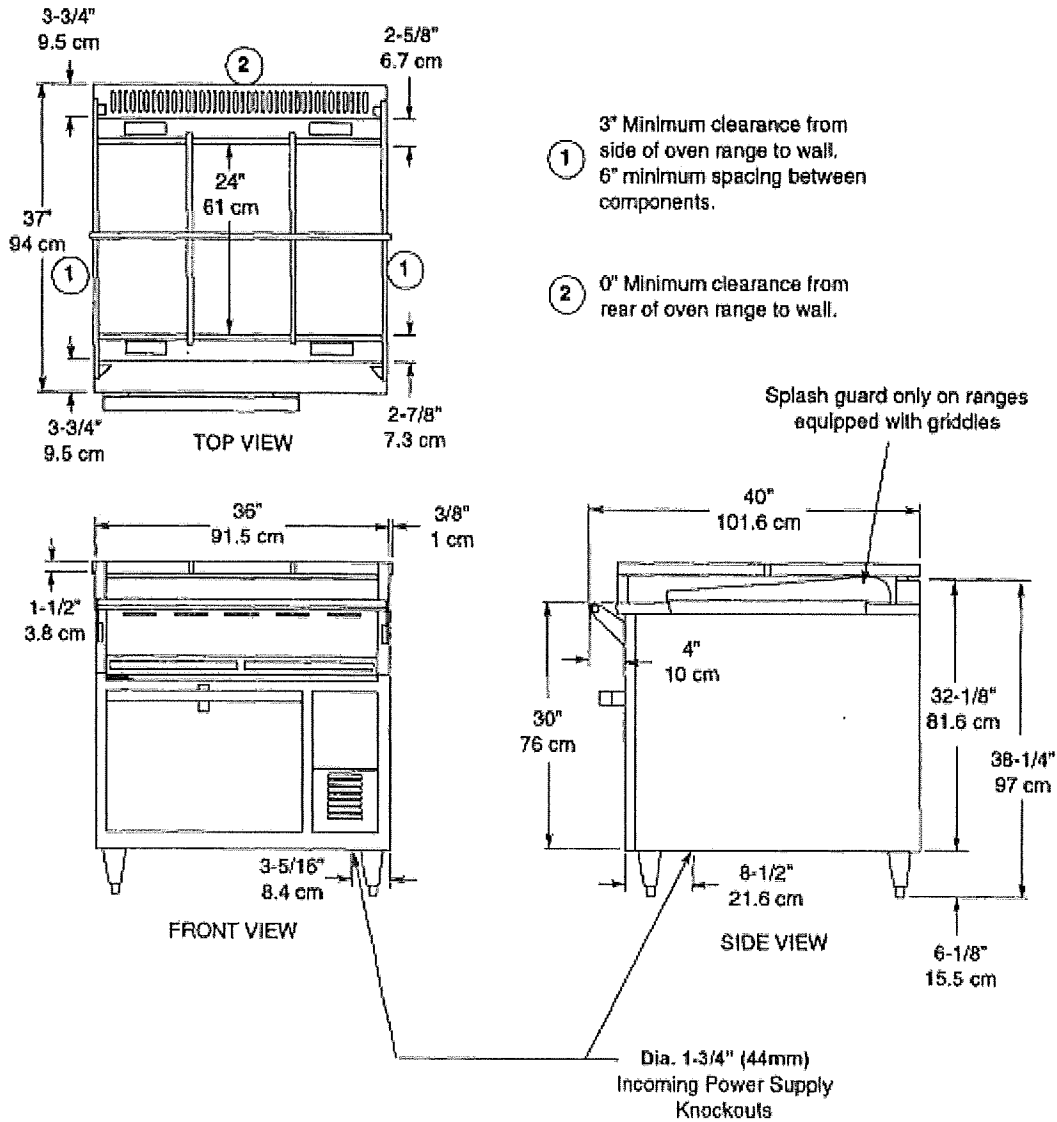

Figure 2-4

SECTION 2 - INSTALLATION

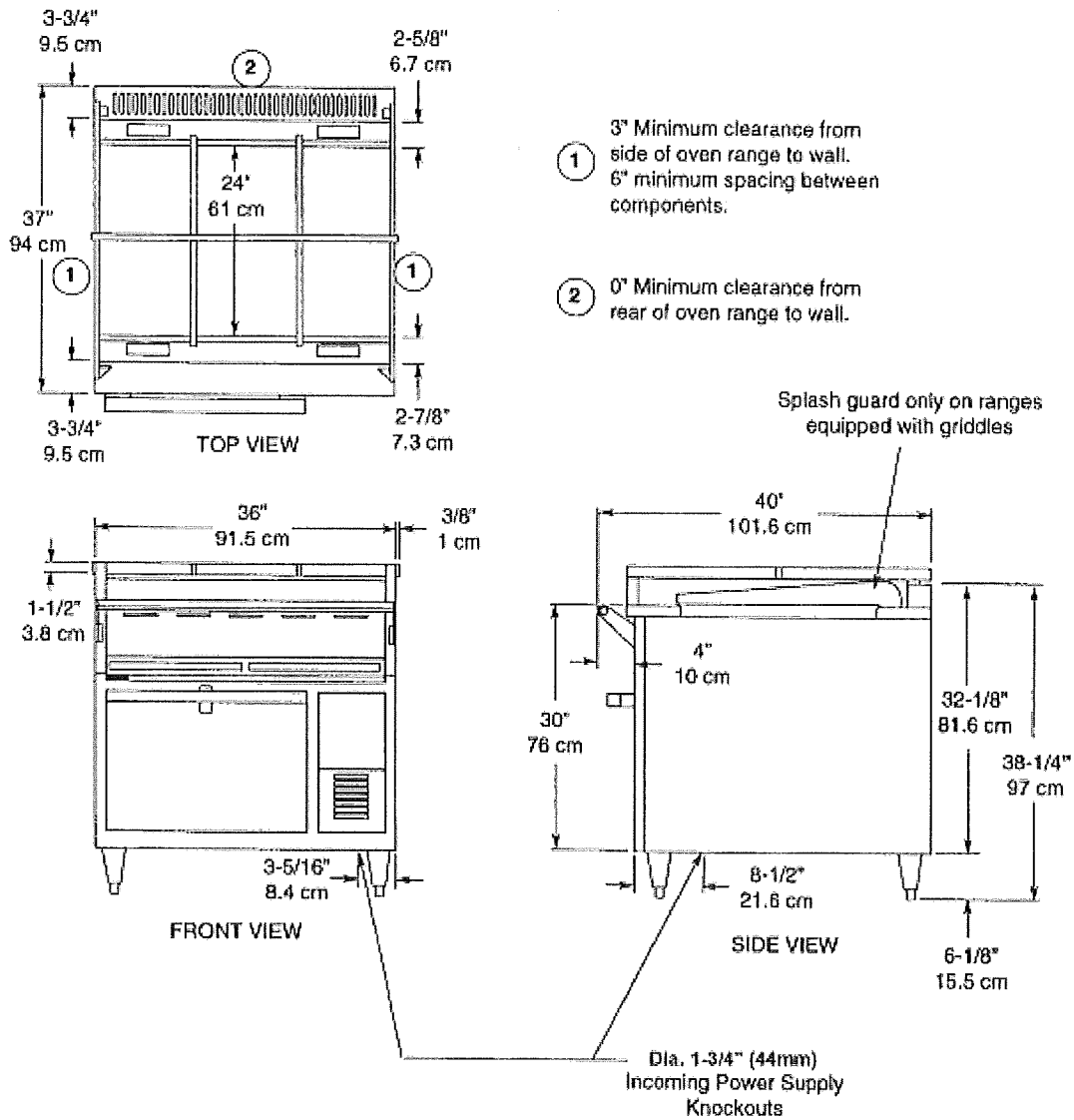

Figure 2-5

SECTION 3

OPERATION

I. Component Function and Location

- A. **Oven Base** - either a convection or a deck oven base.
Convection Oven heating element located on side of oven cavity with the blower fan.
Deck Oven has a heating element at both the top and bottom of the oven cavity.
- B. **Oven Base Control Panel** - contains all operator controls for oven operation.
- C. **Range Top** - is configured six different ways which consist of griddles, round hot plate and/or 12" x 24" hot plates.
- D. **Range Top Control Panel** - contains all operator controls for range operation.
- E. **Grease Troughs (Front & Back)** - catch grease from the range top griddles and hot plates.
- F. **Grease Drawers** - grease is drained from the grease troughs through grease chutes and into the grease drawers.
- G. **Vent Damper Control** - controls the amount of moisture that can be vented from the oven.

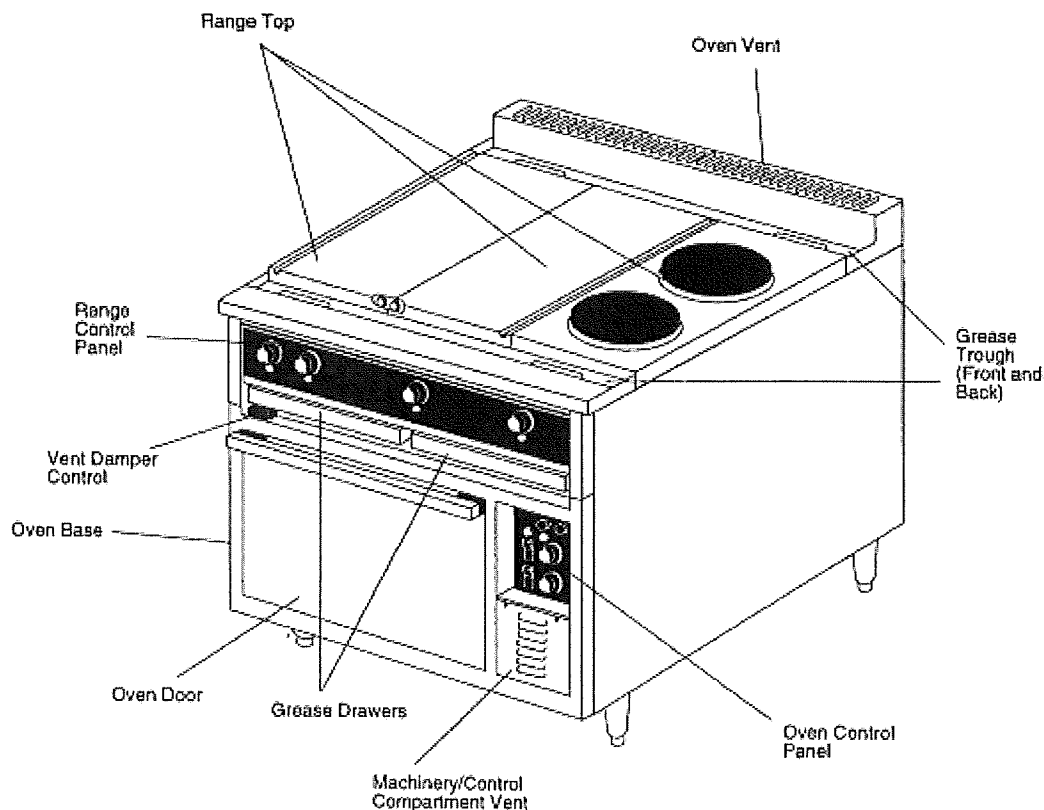

Figure 3-1
Convection

SECTION 3 - OPERATION

II. Control Functions and Locations

A. Convection Oven Control Panel

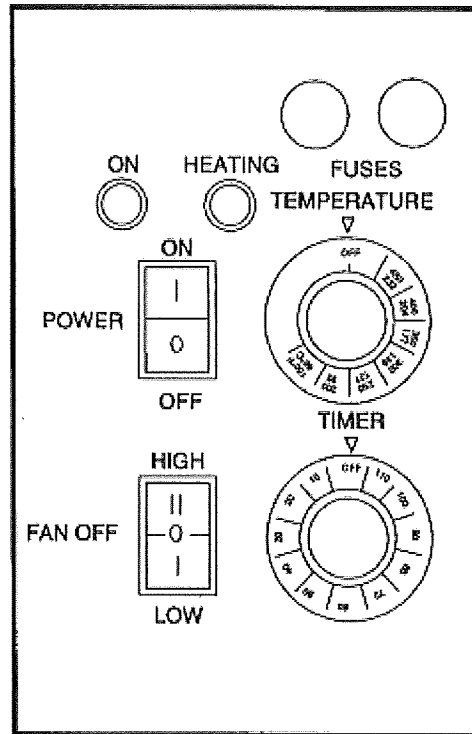

Figure 3-2
Convection Control Panel

1. **Temperature Thermostat Control** - adjustable from 150°F to 450°F (65°C to 232°C). The thermostat is also provided with ON/OFF position. The oven will preheat to 450°F (232°C) in 15 minutes.
2. **Heating Light** - Amber light signals when oven is coming up to set temperature and heating element is on.
3. **Power Switch** - turns oven ON or OFF.
4. **On Light** - Green light signals when power is on.
5. **Timer** - adjustable from 6 to 120 minutes.
6. **Fan Switch** - turns fan to LOW or HIGH speed and turns fan OFF. If fan switch is turned OFF the heating element will not heat. Fan switch must be positioned in LOW or HIGH for oven to heat up.
7. **Fuse Holders** - contain amp fuse and amp fuses.

B. Deck Oven Control Panel

Figure 3-3
Deck Control Panel

1. **Temperature Thermostat Control** - adjustable from 200°F to 500°F(93°C to 287°C). The thermostat is also provided with ON/OFF position. The oven will preheat to 450°F(232°C) in 20 minutes.
2. **Upper and Lower Heating Element Switches** - are 3 position switches which adjust the heating elements at low, medium or high. The heating element switches also have an OFF position.
3. **Heating Light** - Amber light signals when oven is coming up to set temperature and heating element switches are energized. If the heating element switches are "OFF" the oven will not heat, even though the light the light is on.
4. **Timer** - Adjustable from 6 to 120 minutes.

Section 3 - OPERATION

C. Range Top Controls

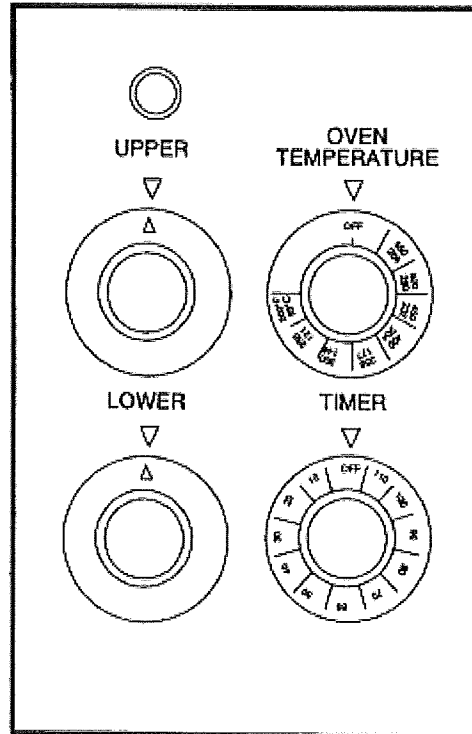
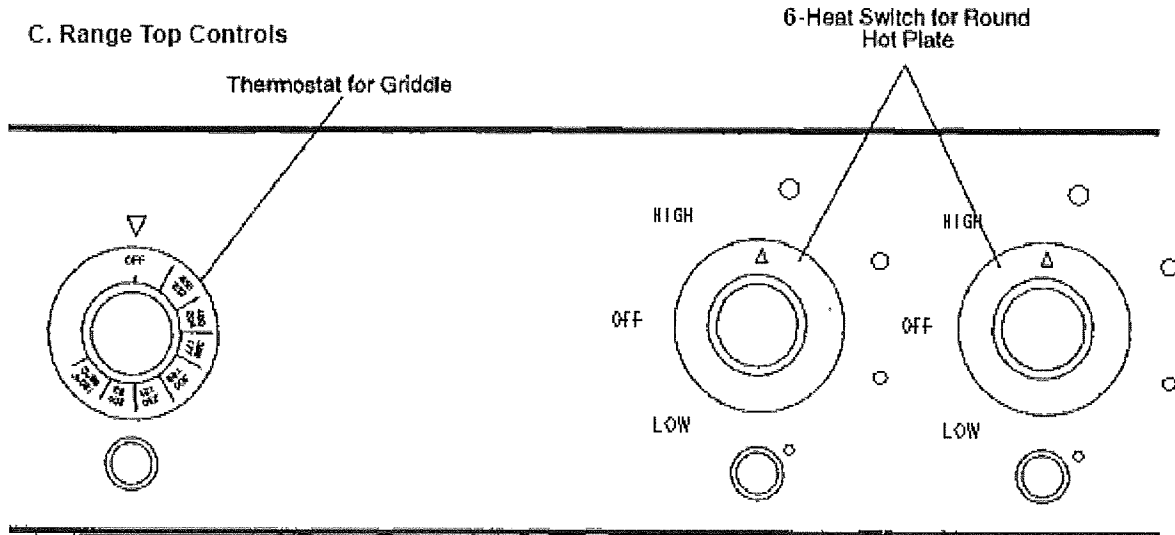

Figure 3-4

Range Top with Griddle Control

1. Griddle is controlled by a Temperature Thermostat Control (see Figure 3-4) adjustable from 150°F to 450°F (65°C to 232°C). The griddle will preheat to 400°F (204°C) in 12 minutes. Adjacent green light remains on while heating elements are energized and griddle is coming up to set temperature.

Griddles have independent heat zones each with its own heating element and temperature control. The 24" x 24" griddle has two 12" heat zones and the 24" x 36" griddle has four 9" heat zones.

2. 12" x 24" Hot Plate is controlled by a Temperature Thermostat Control (see Figure 3-5) adjustable from 250°F to 850°F (121°C to 455°C). The 12" x 24" hot plate will preheat to 400°F (204°C) in 12 minutes. Adjacent green light remains on while heating elements are energized and griddle is coming up to set temperature.
3. Round Hot Plate is controlled by a 6-heat switch. The switch positions are LOW, HIGH and OFF. Adjacent green light is always on while hot plate is on.

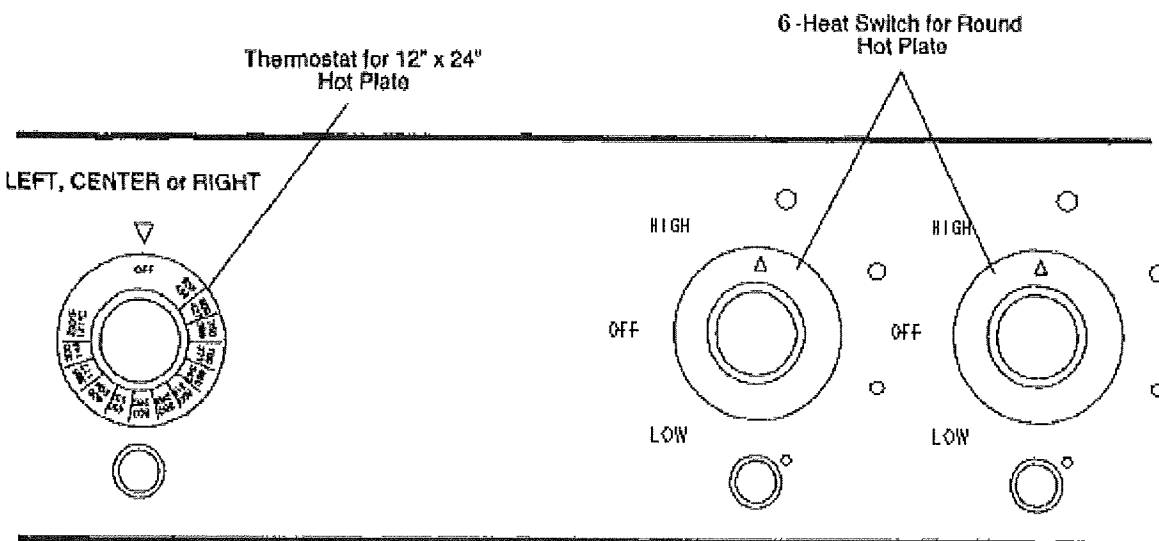

Figure 3-5

Range Top with Hot Plate Control

III. Operation

A. Convection Oven Operation

1. Set temperature control knob to the desired temperature.
2. Push the oven power switch to the ON position.
3. Push the fan switch to the HIGH or LOW position. The LOW fan speed should be used for delicate products or products with loose toppings such as pepperoni on a pizza. Use HIGH fan speed for all other products that will not be affected by a fast air movement.
4. Allow oven to preheat to the set temperature. The amber signal light will remain on until the set temperature has been reached.
5. Place pans containing food products into oven and set timer for desired cook time. Refer to the Time and Temperature Charts on the following pages for suggested cook times and temperatures. When placing pans in oven do not block air flow on sides or in back of oven cavity. Blocking the air flow can cause uneven cooking.

Opening the oven door too often will also cause uneven cooking. Keep oven door closed except for necessary checking of food products.

6. Flue vent damper should be opened when cooking high moisture content foods. Pull the flue vent handle to open the vent damper.
7. When timer signals that cooking time has elapsed remove food product and turn power switch, temperature control and fan switch to OFF.

8. CONVECTION OVEN CLEANING

- a. At the end of the day's operation be sure the oven is turned off.
- b. Open the oven door and allow it to cool down.
- c. Remove the oven racks.
- d. Remove the oven rack hangers by lifting up and off of the screw studs holding them in place.
- e. Remove the baffle surrounding the fan by removing the three screws on the front and pulling the baffle forward.
- f. All racks, rack hangers and fan baffle can be washed in warm soapy water, rinsed and wiped dry.
- g. Wash the blower wheel.
- h. Using a stiff brush (not wire), clean the interior of baked on food particles. Using a mild detergent and damp sponge wipe down the inside of the oven and the oven door. Rinse and wipe dry. If these procedures are followed daily, it will prevent food particles from building up and creating hard to remove stains. Do not use strong abrasives as they will scratch the finish.

SECTION 3 - OPERATION

B. Deck Oven Operation

1. Set temperature control knob to the desired temperature.
2. Turn both Upper and Lower element switches to HIGH.
3. Allow oven to preheat to the set temperature. The amber signal light will remain on until the set temperature has been reached.
4. After oven is preheated set Upper and Lower element switches to desired setting (LOW, MEDIUM or HIGH).

When roasting, the best results are obtained by using balanced heat with both the Upper and Lower element switches on HIGH. A measured top heat provides excellent coloring and a caramelized finish to the meats, but where a seared or browned appearance is not desired, as in roasting fowl, the upper oven element switch should be set on MEDIUM, LOW or OFF.

5. Place pans containing food products into oven. For baking and roasting, pans should be placed on the intermediate rack. When roasting and baking pans are on both the deck and the rack the pans should be rotated halfway through the cooking cycle.

When placing pans in oven do not block air flow on sides or in back of oven cavity. Blocking the air flow can cause uneven cooking.

Opening the oven door too often will also cause uneven cooking. Keep oven door closed except for necessary checking of food products.

6. Set timer for desired cook time. Refer to the Time and Temperature charts on the following pages for suggested cook times and temperatures.
7. Flue vent damper should be opened when cooking high moisture content foods. Pull the flue vent handle to open the vent damper.
8. When the timer signals that cooking time has elapsed remove food product and turn temperature control and Upper and Lower element switches to OFF.

9. DECK OVEN CLEANING

- a. At the end of the day's operation be sure the oven is turned OFF.
- b. Open the oven door and allow it to cool down.
- c. Remove the oven rack and the oven deck at the bottom of the oven.
- d. Oven rack and deck can be washed in warm soapy water, rinsed and wiped dry.
- e. Using a stiff brush (not wire), clean the interior of baked on food particles. Using a mild detergent and damp sponge wipe down the inside of the oven and the oven door. Rinse and wipe dry. If these procedures are followed daily, it will prevent food particles from building up and creating hard to remove stains. Do not use strong abrasives as they will scratch the finish.

SECTION 3 - OPERATION

C. Griddle Operation

IMPORTANT: Do not turn griddle on before seasoning procedure has been completed.

IMPORTANT: If your griddle is new you must remove the rust preventive material before turning the griddle on. Refer to Section 2, Installation, Paragraph E.

1. Griddle Seasoning Procedure

- a. Preheat the griddle to 300°F (149°C) and spread a light film of unsalted cooking oil or fat over the surface with a soft cloth.
- b. Allow griddle to stand this way for two minutes to give the oil an opportunity to work into the pores of the metal and to form a smooth coating over the outside.
- c. Wipe off excess oil and repeat Steps 1 and 2 at 350°F (175°C).
- d. After the second step is complete wipe off excess cooking oil, set thermostat control knob for desired temperature. The griddle is now ready for use.

2. Operating Hints and Safety

Although the finest materials, engineering planning and manufacturing facilities have provided for safety and trouble-free operation only proper used and maintenance will assure personnel safety and long life of the equipment. The following are a few precautions and operating suggestions for use of the griddle.

- a. Disconnect power to the griddle at the disconnect switch at the end of each day of operation.
- b. Do not leave griddle in operation without an attendant.
- c. Turn thermostat dials down to 200°F (93°C) during idle periods. It takes only a few minutes to regain operating temperatures.
- d. Do not heat the entire griddle for cooking small amounts of food.
- e. Various kinds of food can be cooked at the same time by setting each section of the griddle at different temperatures.
- f. Use a spatula to push excess grease into grease trough after each load of food is cooked. This will reduce smoking of hot grease and carbonizing.
- g. Do not leave griddle at high temperature when not in use or during idle periods. This will cause food particles and grease film to carbonize.

3. Daily Griddle Operation And Maintenance

Daily Pre-Operation:

- a. Season the griddle before operation daily as described in Step 1 above.
- b. Turn the temperature controls to the desired temperature and allow 15 minutes of preheat time before loading griddle with food. Green signal light will remain on while heating elements are energized and griddle is coming up to set temperature. This will allow time for the griddle surface to be saturated with heat. Failure to allow sufficient preheat time will result in unsatisfactory cooking of the first load. The following chart indicates cooking time and temperature for various type of food.
- c. If a portion of the griddle is to be used for holding then set the temperature controls for different temperatures.

SECTION 3 - OPERATION

Daily Post-Operation:

a. Cleaning the Griddle Surface

AA. Good cooking requires clean equipment. To provide evenly cooked and perfectly browned foods, keep the griddle surface free of carbonized grease. Carbonized grease on griddle surface hinders the transfer of heat from the griddle surface to the food. This also results in spotty browning, loss of cooking efficiency, and worst of all, carbonized grease tends to cling to the griddled foods, giving them a highly unsatisfactory and unappetizing appearance.

BB. At the end of each day of operation or at the end of each shift thoroughly clean the front and rear grease troughs and the chutes into grease drawers.

CC. Clean the griddle surface with a pumice or griddle stone by rubbing with the grain of the metal while the griddle surface is still warm. Wipe griddle clean of residue from the griddle stone.

b. Cleaning - Wipe down sides of griddle and all areas around griddle to keep them free of splashed grease.

AA. Clean all surrounding surfaces of the griddle with warm water and a mild detergent daily.

BB. Rinse and wipe off excess water.

CC. Polish with a dry soft cloth.

***NOTE:** This simple treatment not only keeps the equipment dirt free and sparkling, it also eliminates the danger of grease accumulation forming hard to remove stains.*

c. Cleaning the grease drawer - Empty each grease drawer as often as necessary, but they must be emptied at the end of each day of operation or the end of each shift. Also wash out grease drawers with hot water and a mild detergent. Wipe dry and replace in range. **NOTE:** Marine ranges are equipped with a grease drawer latch which must be held depressed as the grease drawers are removed.

SECTION 3 - OPERATION

D. 12" x 24" Hot Plate Operation

IMPORTANT: If your hot plate is new you must remove the rust preventive material before turning the griddle on. Refer to Section 2, Installation, Paragraph E.

1. Turn the temperature controls to the desired temperature and allow 15 minutes of preheat time before using hot plate. The green signal light will remain on while the heating elements are energized and the hot plate is coming up to set temperature.
2. When hot plate is preheated place pots or vessels onto hot plate for cooking.
3. HOT PLATE CLEANING
 - a. Wash range with warm soapy water, rinse and wipe dry.
 - b. Be sure to clean all surfaces around and on the hot plates.
 - c. Polish with a soft dry cloth.

E. Round Hot Plate Operation

1. Turn the 6-heat switch to the desired setting. Allow the hot plate to preheat for 10 minutes and then place pots or vessels onto hot plate for cooking.
2. Green signal light will remain on until 6-heat switch is turned to the OFF position.
3. ROUND HOT PLATE CLEANING
 - a. Wash range with warm soapy water, rinse and wipe dry.
 - b. Be sure to clean all surfaces around and on the hot plates.
 - c. Polish with a soft dry cloth.

F. Marine Ranges

Marine ranges are provided with a full width grab bar, 6" marine bolt-down legs, an oven door latch and sea rails to prevent movement of pots on range top.

The range top sea rails may have to be repositioned when various size pots or vessels are used.

SECTION 3 - OPERATION

IV. Time and Temperature Charts

DECK OVEN BAKING TIME AND TEMPERATURE

PRODUCT	TEMPERATURE	TOP SWITCH	BOTTOM SWITCH	TIME IN MINUTES
Two Crust Pies	400°F to 425°F (204°C to 218°C)	Medium	High	40-60
Open Face Pies	400°F to 425°F (204°C to 218°C)	Medium	High	35-50
Pumpkin Pies	375°F to 400°F (190°C to 204°C)	Medium	Medium	35-50
Custard Pies	375°F to 400°F (190°C to 204°C)	Medium	Medium	35-50
Meringue Pie (Brown)	425°F to 450°F (218°C to 232°C)	High	Off	5-6
Pie Shells	400°F to 425°F (204°C to 218°C)	Medium	Medium	20-30
Parker House Rolls	400°F to 425°F (204°C to 218°C)	Medium	Medium	20-30
Whole Wheat Rolls	375°F to 400°F (190°C to 204°C)	Medium	Medium	20-30
Danish Rolls	375°F to 400°F (190°C to 204°C)	Medium	Medium	20-30
Sweet Rolls	375°F to 400°F (190°C to 204°C)	Medium	Medium	20-30
Kolacky	375°F to 400°F (190°C to 204°C)	Medium	Medium	10-15
Tea Biscuits	375°F to 400°F (190°C to 204°C)	Medium	Medium	20-25
Corn Bread	400°F to 425°F (204°C to 218°C)	Medium	Medium	25-35
Cup Cakes	400°F to 425°F (204°C to 218°C)	Medium	Medium	15-20
Layer Cakes	350°F to 375°F (176°C to 190°C)	Medium	Medium	20-30
Loaf Cakes	350°F to 375°F (176°C to 190°C)		Medium	45-60
Angel Food Cakes	300°F to 325°F (149°C to 163°C)	Medium	Medium	40-50
Puddings	325°F to 375°F (163°C to 190°C)	Medium	Medium	35-60
Baked Apples	300°F to 325°F (149°C to 163°C)	Low	Low	60-70

* Used when the crust and filling are baked as a unit. When the crust is pre-baked most bakers use a temperature of approximately 300°F to 350°F (149°C to 176°C).

NOTE: The data in this chart is of a general nature and is suggested for use as a guide only. Experience will, of course, dictate variations that best fit your baking requirement.

DECK OVEN ROASTING TIME AND TEMPERATURE

	PRODUCT	CONTROL SETTING	INTERNAL MEAT TEMPERATURE	MINUTES PER POUND
Beef	Standing Rib. 3 Rib. 6-8 pounds	300°F (149°C)	Rare 140°F (60°C)	20
			Med. 160°F (71°C)	25
			Well 170°F (77°C)	30
	Standing Rib. 7 Rib. 20-25 pounds	300°F (149°C)	Rare 125°F (52°C)	13
			Med. 140°F (60°C)	15
			Well 150°F (65°C)	17
Rolled Rib. 7 Rib. 16-18 pounds	250°F (121°C)	Well 150°F (65°C)	25	
Rump or Chuck. 8-23 pounds	300°F (149°C)	140°F to 170°F (60°C to 77°C)	20 to 30	
Round Rump, Shank off. 50 pounds	300°F (149°C)	140°F to 170°F (60°C to 77°C)	12 to 16	
Lamb	Leg. 7-8 pounds	300°F (149°C)	180°F (82°C)	30 to 35
	Leg. 15-20 pounds	300°F (149°C)	160°F (71°C)	20 to 30
	Shoulder	300°F (149°C)	180°F (82°C)	40 to 45
	Breast, Stuffed	300°F (149°C)	175°F to 180°F (79°C to 82°C)	30 to 35
Pork	Ham Leg. 15 pounds	350°F (176°C)	185°F (85°C)	30 to 35
	Ham Leg. 25 pounds	350°F (176°C)	185°F (85°C)	30 to 35
	Ham Boned. 15 pounds	350°F (176°C)	185°F (85°C)	30 to 35
	Loin	350°F (176°C)	185°F (85°C)	
	Boston Butt	350°F (176°C)	185°F (85°C)	45 to 50
	Ham, Cured. 20 pounds	300°F (149°C)	160°F (71°C)	15 to 18
Veal	Leg. 16 pounds	300°F (149°C)	170° (77°C)	22
	Leg. 25 pounds	300°F (149°C)	170° (77°C)	18 to 20
	Shoulder. 15 pounds	300°F (149°C)	170° (77°C)	25
	Shoulder. Rolled. 15 pounds	300°F (149°C)	170° (77°C)	35 to 40
	Loin. 10 pounds	300°F (149°C)	170° (77°C)	25 to 30
Fowl	Chicken. Dressed. 4-6 pounds	250°F to 300°F (121°C to 149°C)	190°F (88°C)	35 to 40
	Duck. Dressed. 5-8 pounds	300°F (149°C)	190°F (88°C)	25 to 30
	Turkey. Dressed. 14-19 pounds	300°F (149°C)	190°F (88°C)	20 to 25
	Turkey. Dressed. 27-33 pounds	300°F (149°C)	190°F (88°C)	15 to 20

NOTE: The above data is of a general nature. Many factors such as size of bone, thickness of meat, temperature at time of roasting, individual taste as to degree of doneness, seasoning, etc., must be taken into consideration. Pan selection and cooking times will also be governed by total weight, number of pieces in load. Preheating for roasting is unnecessary.

SECTION 3 - OPERATION

**CONVECTION OVEN BAKING
TIME & TEMPERATURE**

This chart provides recommended temperature and time settings plus number of racks used per oven for specific food products. The times and temperatures may, however, vary considerable due to weight of load, type of utensils and recipe.

PRODUCT	SIZE OF PAN	NO. OF RACKS	YIELD	TEMP. SETTING	TIME SETTING
Frozen Berry Pies, 22 oz.	9" diameter	3	18	350°F (176°C)	34 min.
Frozen Fruit Pies, 46 oz.	9" diameter	3	12	350°F (176°C)	45-50 min.
Fresh Apple Pies, 22 oz.	9" diameter	3	18	350°F-375°F(176°C-190°C)	25-30 min.
Sheet Cake	18" x 26"	3	3	335°F (168°C)	16-18 min.
Corn Bread	18 x 26"	3	3	335°F (168°C)	25 min.
Bread, 1 lb. Loaves		2	16	340°F (171°C)	30 min.
Sugar Cookies, 3" diameter	18" x 26"	3	144	300°F (149°C)	15 min.
Brownies	12" x 20" x2"	3	6	350°F (176°C)	15 min.
Beef Pot Pies, 5" diameter	5" diameter	3	60	400°F (204°C)	30-35 min.
Turkey or Chicken Pot Pies	5" diameter	3	60	400°F (204°C)	30-35 min.
Stuffed Peppers		2		350°F (176°C)	15-20 min.
Toasted Cheese Sandwiches	12" x 20"	3	90	400°F (204°C)	8 min.
Hamburger Patties, 5 per lb.	18" x 26"	6	144	400°F (204°C)	8-10 min.
Chicken, Qtrd. (2-1/2 lb. Avg.)	18" x 26"	3	75	350°F (176°C)	30 min.
Chicken Breast - Thigh	18" x 26"	3		350°F (176°C)	40 min.
Individual Pizza (Frozen)	5" diameter	3	60	450°F (232°C)	5 min.
Halibut Steaks (5 oz. Frozen)	18" x 26"	3	90	350°F (176°C)	20 min.
Rolled Roast Beef (20 lb. Avg.)		2	80	300°F (149°C)	4 hours
Meat Loaf		2		325°F 163°C)	40-45 min.
Idaho Potatoes (8 oz. Avg.)	20 per rack	3	60	400°F (204°C)	50 min.

GRIDDLE TIME & TEMPERATURE

NOTE: All cooktimes are approximate.

PRODUCT	CONTROL SETTING	TIME IN MINUTES	ADVANCE PREPARATIONS
Canadian Bacon	350°F (176°C)	3 to 4	Slice (not too far in advance as meat will darken) - Split edges to prevent curling.
Hamburgers	350°F (176°C)	3 to 4	Prepare recipe - Form patties - Separate with waxed paper - Refrigerate.
Cheeseburgers	350°F (176°C)	3 to 4	A hamburger patty plus melt a slice of cheese on top just before serving.
Corned Beef Patties	375°F(190°C)	3 to 4	Open both ends of can - Slide out contents of can - Cut into 3/8" slices.
Sausage Patties	350°F (176°C)	3 to 4	Form patties - Separate with waxed paper - Refrigerate.
Sausage Links	350°F(176°C)	3	Refrigerate for best results.
Potato Patties	375°F(190°C)	3 to 4	Cook - Mash - Season - Form patties using 1/4 cup measure.
American Fried Potatoes	375°F(190°C)	3 to 4	Cook - Slice - Season.
French Toast	400°F(204°C)	4 to 5	Prepare egg batter.
Scrambled Eggs	300°F(149°C)	3 to 4	Prepare recipe.
Pancakes	375°F(190°C)	2	Prepare recipe.
Frankfurters	375°F(190°C)	2 to 5	
Minute Steaks	400°F(204°C)	3 to 4	
Club Steaks	400°F(204°C)	3 to 5	
Ham Steaks	400°F(204°C)	10	
Beef Tenderloin	400°F(204°C)	5 to 7	
Boiled Ham	375°F(190°C)	2	
Bacon	350°F(176°C)	6	
Hard Fried Eggs	300°F(149°C)	3	
Soft Fried Eggs	300°F(149°C)	2	
Sunny-Side-Up Eggs	300°F(149°C)	3	

SECTION 3 - OPERATION

NOTES

SECTION 4

PARTS LIST

**Order parts by calling your local authorized
Southbend Parts Distributor.
They have a complete inventory of parts for all
Toastermaster equipment.**

SECTION 4 - PARTS LIST

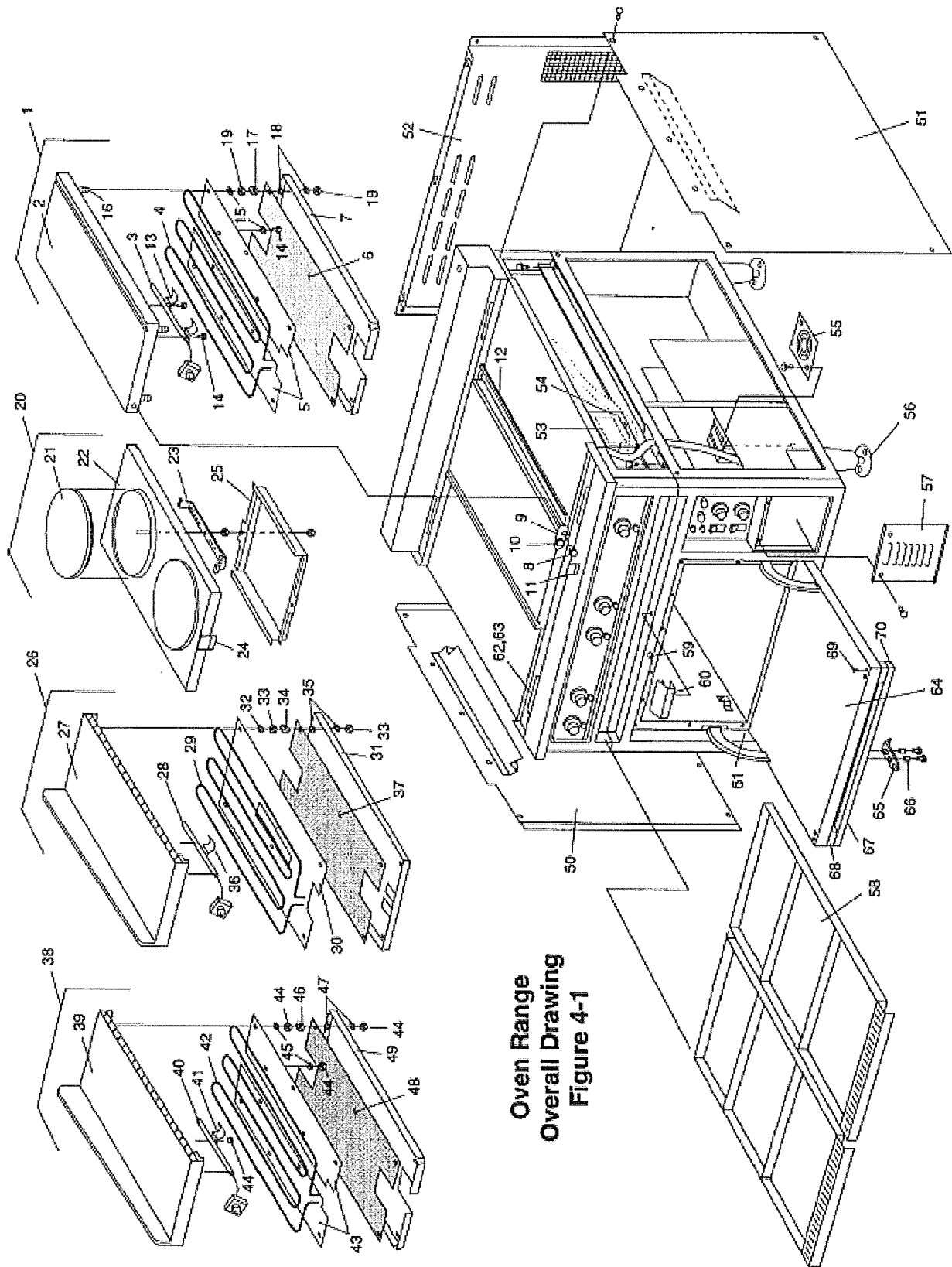

Oven Range
Overall Drawing
Figure 4-1

Oven Range Overall Parts List



SECTION 4 - PARTS LIST

ITEM NO	QTY	PART NO.	DESCRIPTION	ITEM NO	QTY	PART NO.	DESCRIPTION
1	1	7600083	12 x 24 PLATE COMPLETE - RIGHT DRAIN 208V	29	4	7D1E1	ELEMENT 208V
1	1	7600084	12 x 24 PLATE COMPLETE - RIGHT DRAIN 240V	29	4	7D1E29	ELEMENT 240V
1	1	7600085	12 x 24 PLATE COMPLETE - RIGHT DRAIN 480V	29	4	7D1E28	ELEMENT 480V
1	1	7600087	12 x 24 PLATE COMPLETE - LEFT DRAIN 208V	30	4	20G1A37	ELEMENT CLAMP PLATE
1	1	7600088	12 x 24 PLATE COMPLETE - LEFT DRAIN 240V	31	4	20G1A38	ELEMENT BAFFLE
1	1	7600090	12 x 24 PLATE COMPLETE - LEFT DRAIN 480V	32	24	F706A8809	WASHER 11/32 x 1-1/4
1	1	7600074	12 x 24 PLATE COMPLETE - CENTER 208V	33	48	F706A8807	HEX NUT, BRASS 1/4-20
1	1	7600075	12 x 24 PLATE COMPLETE - CENTER 240V	34	24	F706A8811	SPACER
1	1	7600077	12 x 24 PLATE COMPLETE - RIGHT DRAIN 480V	35	28	F706A8805	WASHER 1/4"
1	1	7601872	12 x 24 PLATE COMPLETE - DRAIN BOTH SIDES 208V (USED ON MODELS SE380D/A-TTH)	36	4	7002270	THERMOSTAT BULB CLAMP
1	1	7601873	12 x 24 PLATE COMPLETE - DRAIN BOTH SIDES 240V (USED ON MODELS SE380D/A-TTH)	37	4	8500079	INSULATION
1	1	7601875	12 x 24 PLATE COMPLETE - DRAIN BOTH SIDES 480V (USED ON MODELS SE380D/A-TTH)	38	1	7603538	24 X 24 GRIDDOLE PLATE COMPLETE 208V
2	1	200A1G1	12 x 24 PLATE ONLY DRAIN BOTH SIDES	38	1	7603539	24 X 24 GRIDDOLE PLATE COMPLETE 240V
2	2	20A2G3	12 x 24 PLATE ONLY RIGHT OR LEFT	38	1	7603541	24 X 24 GRIDDOLE PLATE COMPLETE 480V
2	2	20A2G9	12 x 24 PLATE ONLY CENTER	39	1	7603536	24 X 24 GRIDDOLE ONLY
3	3	300A2B1	(USED ON MODELS SE380D/A-TTH)	40	2	300A257	THERMOSTAT
4	3	2100094	12 x 24 PLATE ONLY DRAIN BOTH SIDES	41	4	2100059	THERMOSTAT KNOB 150°F (66°C)-450°F (232°C)
4	3	F706A8703	12 x 24 PLATE ONLY RIGHT OR LEFT	42	2	F706A8703	THERMOSTAT BULB CLAMP
4	3	F706A8731	THERMOSTAT	42	2	F706A8731	ELEMENT 208V
4	3	F706A8729	THERMOSTAT KNOB 250°F (121°C)- 850°F (454°C)	42	2	F706A8729	ELEMENT 240V
5	6	20A2G1	ELEMENT 208V	43	4	20A2G1	ELEMENT CLAMP PLATE
5	6	F706A8729	ELEMENT 240V	44	26	5301A8617	HEX NUT 1/4-20
6	3	8500079	ELEMENT 480V	45	20	F706A8809	WASHER 1-1/4" OD
7	3	F706A1017	ELEMENT CLAMP PLATE	46	8	F706A8811	SPACER
8	4	20A2G7	INSULATION	47	16	F706A8805	WASHER 1/4"
8	4	20A2G6	BAFFLE	48	2	8500079	INSULATION
9	4	20A1G7	LATCH SCREW	49	2	F706A1017	BAFFLE
10	4	20A1G7	LATCH PLATE	50	1	33817	WELDMENT, EXT. PANEL, LEFT HAND
11	4	342B4	LATCH PIN	51	1	33818	WELDMENT, EXT. PANEL, RIGHT HAND
12	2	20A1G8	CLIP, RETAINING 12 x 24 HOTPLATE	52	1	33849	REAR PANEL
13	6	F706A1013	KEY STRIP	53	1	30905	TERMINAL BLOCK, 3 POLE
14	27	F716A8803	BULB CLAMP	54	1	33816	FLATE COVER
15	30	F706A8809	CAP SCREW 1/4-20 x 3/8	55	1	7007442	KNOCKOUT PLATE
16	12	2001184	WASHER 1-1/4"	56	4	MALG06F	KIT, MARINE LEG 6" SS ADJ.
17	12	F706A8811	STUD 1/4-20 x 1-5/8	57	1	7007392	ACCESS PANEL
18	30	F706A8805	SPACER	58	2	7601840	GREASE DRAWER, HANDLE & ASSEMBLY
19	24	F706A8807	WASHER 1/4"	59	1	32691	LATCH, MARINE
20	103	34797	HEX NUT 1/4-20, BRASS	60	2	34743	LATCH, GREASE DRAWER
20	103	33850	TWIN PLATE ASSEMBLY 208V, 2600W	61	2	34741	RECEIVER FOR LATCH
20	103	34278	TWIN PLATE ASSEMBLY 240V, 2600W	62	4	7610657	DOOR BUSHING
21	206	1132B8701	SOLID ROUND HEATING UNIT 208V ECO-2600W	62	4	2700090	WELDMENT, SPOUT GREASE
21	206	1132B8703	SOLID ROUND HEATING UNIT 240V ECO-2600W	63	4	33893	GASKET, SPOUT GREASE
21	206	34127	SOLID ROUND HEATING UNIT 480V ECO-2600W	64	1	33893	ASSEMBLY, DOOR
22	103	7610114	TWIN PLATE PANEL	65	1	32692	FLATE, LATCH
23	103	1132B8601	RETAINER BAR MOUNTING BRACKET	66	2	34681	SPACER, STEPPED - MARINE LATCH
24	206	34265	RETAINING CLIP	67	1	32572	ASSEMBLY, HANDLE DOOR
25	103	30969	BOTTOM, PLATE	68	2	3103164	SPACER, DOOR & DRAWER HANDLE
26	1	20G1A32	36 x 24 GRIDDOLE PLATE COMPLETE 208V	69	4	2000320	HANDLE SCREWS 10/32 x 3-1/2
26	1	20G1A306	36 x 24 GRIDDOLE PLATE COMPLETE 240V	70	2	3000058	BLACK HANDLE PLUG
26	1	20G1A306	36 x 24 GRIDDOLE PLATE COMPLETE 480V				
27	1	20G1A36	36 x 24 GRIDDOLE PLATE ONLY				
28	4	300A257	THERMOSTAT				
		2100059	THERMOSTAT KNOB 150°F (66°C)-450°F (232°C)				

DECAL RH36C2, RH36D4 CONTROL PANEL (Not Shown)
 DECAL RH36C2/C2, RH36D2/D8 CONTROL PANEL (Not Shown)
 DECAL RH36C1/C3, RH36D1/D7 CONTROL PANEL (Not Shown)
 CONTROL PANEL RH36D4
 CONTROL PANEL RH36C3
 CONTROL PANEL RH36C4

SECTION 4 - PARTS LIST

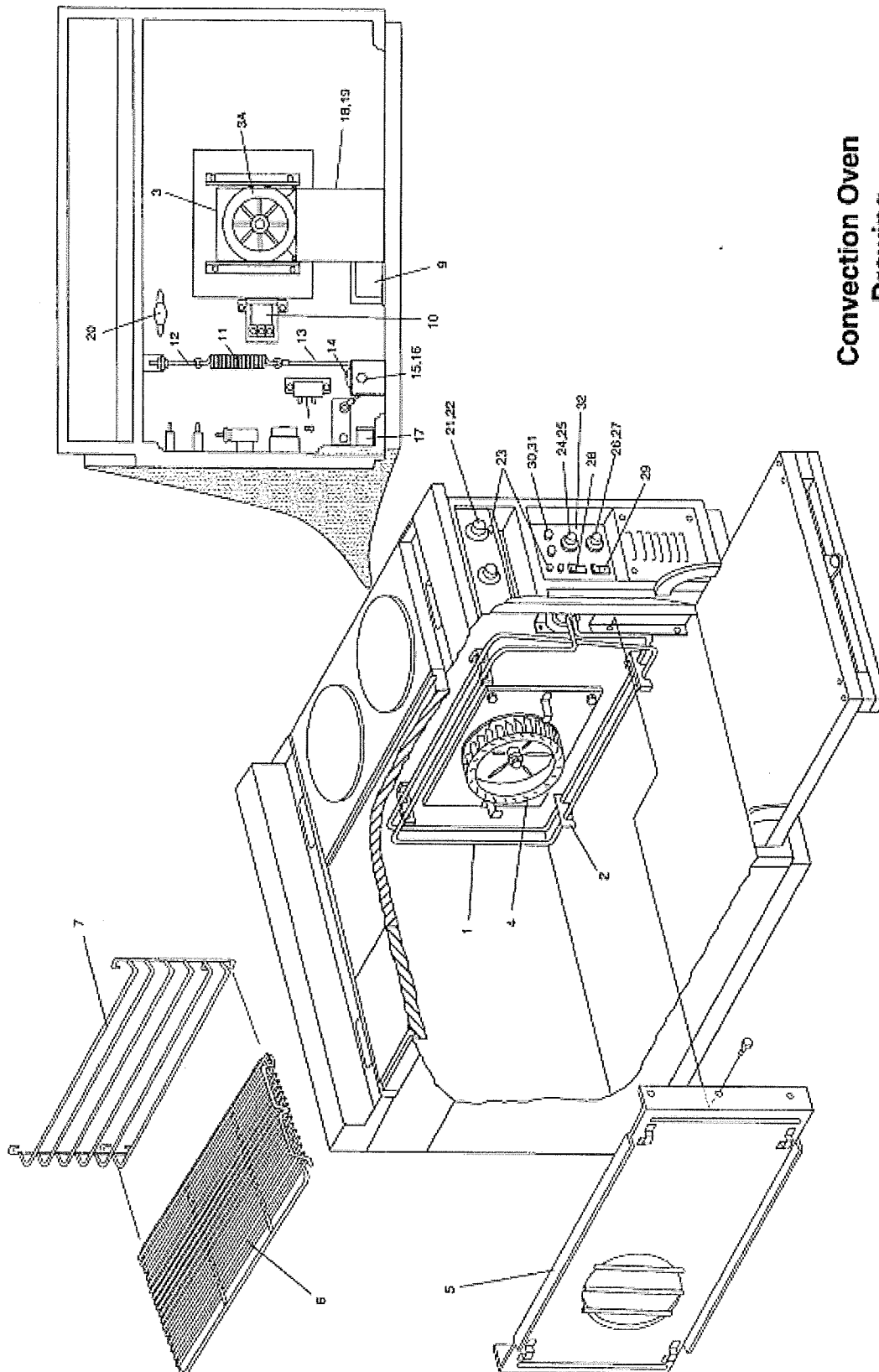

Convection Oven
Drawing
Figure 4-2

**Convection Oven
Parts List**

ITEM NO	QTY	PART NO.	DESCRIPTION
1	1	3027A8701	ELEMENT 6000W-208V
1	1	3027A8711	ELEMENT 6000W-240V
1	1	3027A8709	ELEMENT 6000W-480V
2	4	3027A3083	ELEMENT SUPPORT
3	1	30819	MOTOR BLOWER & ASSEMBLY 240V-480V
3A	1	30D2761	BLOWER MOTOR ONLY 208V-240V
4	1	31D3902	BLOWER WHEEL
5	1	7610513	ELEMENT COVER, BLOWER BAFFLE
6	3	3102541	SHLEF ASSEMBLY
7	2	3102540	SIDE RACK
8	1	30905	TERMINAL BLOCK, 3 POLE
9	1	28082-0010	TRANSFORMER 480V ONLY
10	1	34401	CONTACTOR 208V-240V COIL
11	1	30368	DOOR SPRING
12	1	49685	EYE BOLT
13	1	30369	CABLE ASSEMBLY
14	1	7007809	PULLEY
15	1	30359	AXLE
16	2	3102937	RETAINER RING
17	1	3003770	MICRO SWITCH
18	1	32762	MOTOR DUCT
19	1	34404	MOTOR DUCT SEAL
20	1	30519	HIGH LIMIT SENSOR
21	A/R	1192770	SWITCH, 7-POSITION
22	A/R	1192769	KNOB, 7-POSITION
23	A/R	33413	SIGNAL LIGHT, GREEN 250V
23	A/R	33414	SIGNAL LIGHT, AMBER 250V
23	A/R	33415	SIGNAL LIGHT, WHITE 250V
23	A/R	33417	SIGNAL LIGHT, GREEN 480V
23	A/R	33418	SIGNAL LIGHT, AMBER 480V
23	A/R	33419	SIGNAL LIGHT, WHITE 480V
24	1	2662A8701	THERMOSTAT, C.O. OVEN 150°F (66°C)-450°F (232°C)
25	1	A710E8771	THERMOSTAT KNOB, C.O. OVEN 150°F (66°C)-450°F (232°C)
26	1	3004536	TIMER
27	1	2100088	OVEN TIMER KNOB
28	1	33436	SWITCH, ROCKER, DP/ST
29	1	33437	SWITCH, ROCKER DP/DT
30	2	1455A0341	FUSE HOLDER ASSEMBLY 480V
30	2	1455A0339	FUSE HOLDER ASSEMBLY 240V
31	2	1455A8793	FUSE 240V-10A
31	2	1455A8794	FUSE 480V-10A
32	1	31783	DECAL CONTROL PANEL (Not Shown)

SECTION 4 - PARTS LIST

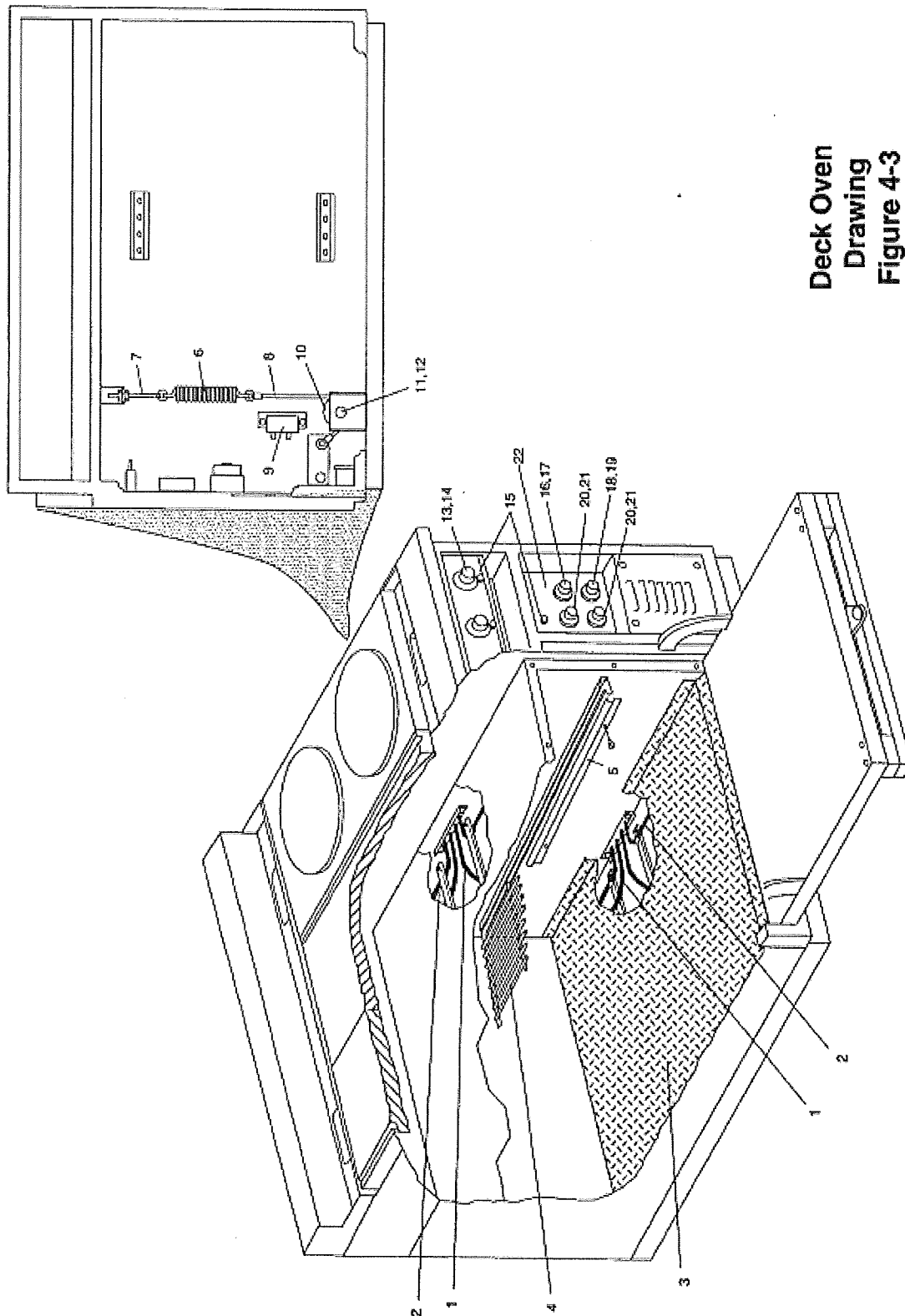

Deck Oven
Drawing
Figure 4-3

SECTION 4 - PARTS LIST

DeckOven
Parts List

ITEM NO	QTY	PART NO.	DESCRIPTION
1	2	3001761	INNER ELEMENT 1500W-208V
1	2	3001762	INNER ELEMENT 1500W-240V
1	2	3001764	INNER ELEMENT 1500W-480V
2	2	3001765	OUTER ELEMENT 1500W-208V
2	2	3001766	OUTER ELEMENT 1500W-240V
2	2	3001768	OUTER ELEMENT 1500W-480V
3	1	30692	OVEN DECK
4	1	30372	OVEN SHELF
5	1	3024A3217	GUARD THERMOSTAT BULB
6	1	30368	SPRING, DOOR
7	1	43685	EYEBOLT
8	1	30369	CABLE ASSEMBLY
9	1	30905	TERMINAL BLOCK, 3 POLE
10	1	7007809	SHEAVE, 3/16 DIA. CABLE (PULLEY)
11	1	30359	AXLE
12	2	3102937	RETAINER RING
13	2to5	1192770	SWITCH,7-POSITION
14	2to5	1192769	KNOB,7-POSITION
15	A/R	33413	SIGNAL LIGHT, GREEN 250V
15	A/R	33414	SIGNAL LIGHT, AMBER 250V
15	A/R	33417	SIGNAL LIGHT, GREEN 480V
15	A/R	33418	SIGNAL LIGHT, AMBER 480V
16	1	3004238	THERMOSTAT DECK OVEN
17	1	A710E8739	THERMOSTAT KNOB DECK OVEN 200°F-550°F
18	1	3004536	TIMER
19	1	210088	KNOB, TIMER
20	2	1192774	SWITCH,4-POSITION
21	2	1194025	KNOB,4-POSITION
22	1	31784	DECAL CONTROL PANEL DECK OVEN

SECTION 4 - PARTS LIST

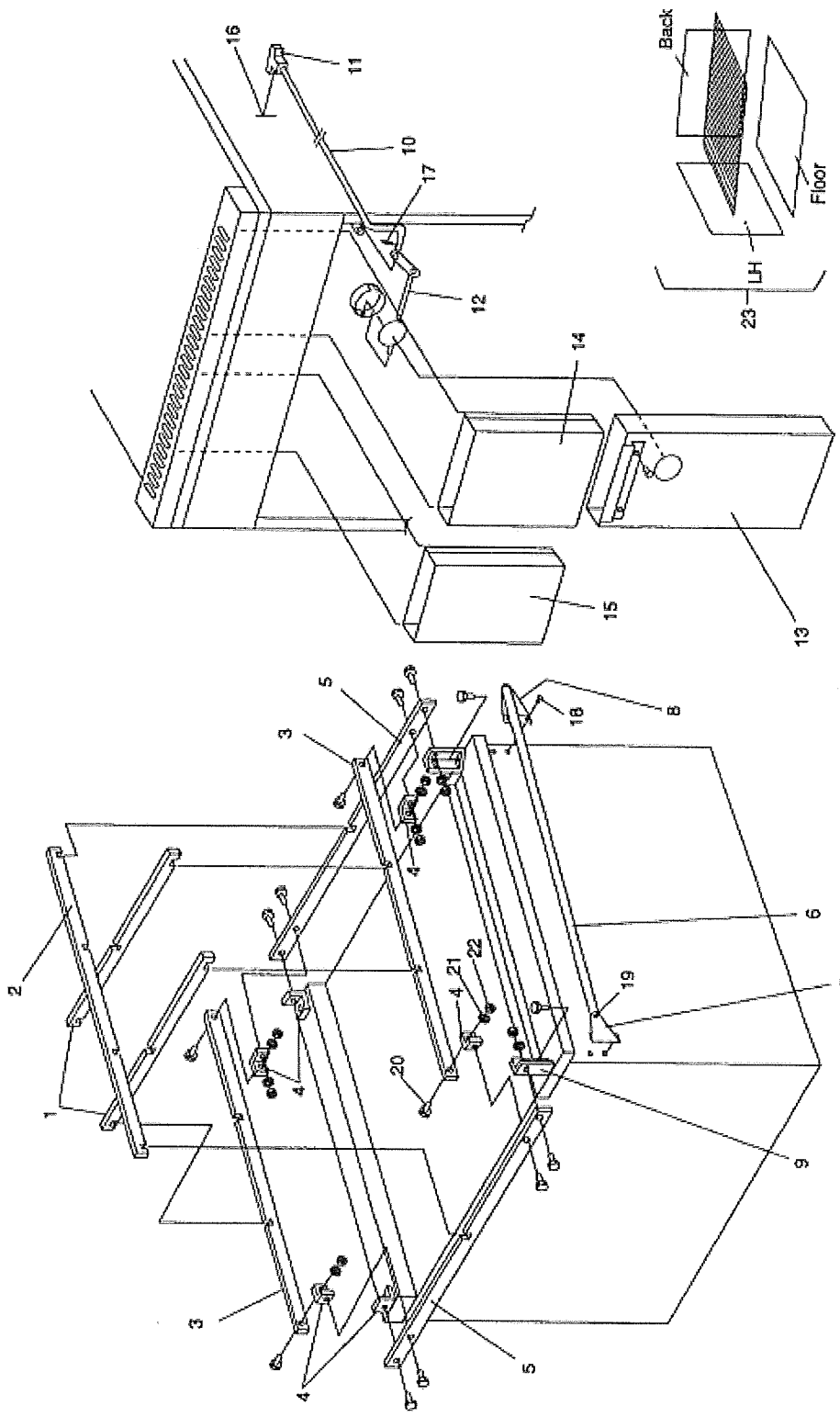

Vents & Marine Rails
 Drawing
 Figure 4-4

Vents & Marine Rails Parts List

ITEM NO	QTY	PART NO.	DESCRIPTION
1	2	33194	RAIL, SEA FRONT TO BACK LOOSE
2	1	33195	RAIL, SEA LEFT TO RIGHT LOOSE
3	2	20A2C77	RAIL, SEA FIXED RIGHT LEFT
4	6	20A2C76	ANGLE, SEA RAIL SECURITY
5	2	20A2C75	RAIL, SEA FIXED FRONT BACK
6	1	20A2C82	RAIL, HAND
7	1	7001408	BRACKET, RAIL LT MARINE
8	1	7001409	BRACKET, RAIL RT MARINE
9	2	7004267	POST, SEA RACKS
10	1	7000071	ROD, VENT RA
11	1	2100053	KNOB, VENT T PULL/OPEN
12	1	7610705	WELDMENT, FLAP VENT
13	1	30412	WELDMENT, FLUE - OVEN SECTION
14	1	30415	WELDMENT, FLUE - TOP SECTION
15	1	32792	WELDMENT, FLUE - TOP SECTION
16	1	2002305	VENT KNOB PIN
17	1	18A12	COTTER PIN
18	4	2000552	SCREW 5/16-18 x 3/4
19	2	4113A8801	SCREW FHM 1/4-20 X 1/2
20	16	2281	SCREW 5/16-18 x 7/16
21	16	4039A8803	LOCKWASHER 5/16
22	12	1411D8815	HEX NUT 5/16-18
23	1	34518	STAINLESS STEEL LINER KIT

SECTION 4 - PARTS LIST

NOTES

SECTION 5

SCHEMATICS

SECTION 5 - SCHEMATICS

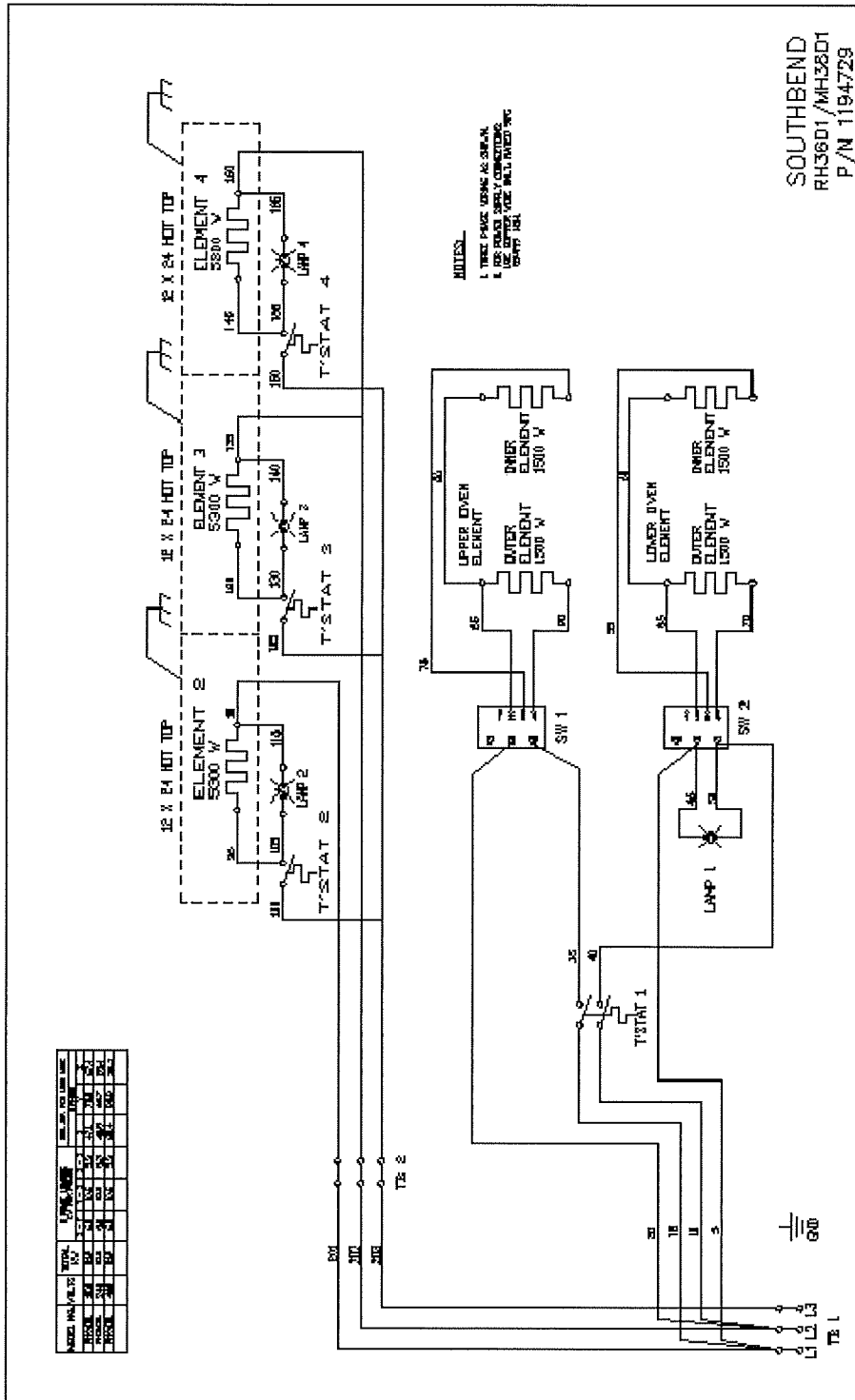

SE36D-HHH WIRING DIAGRAM
208/240V

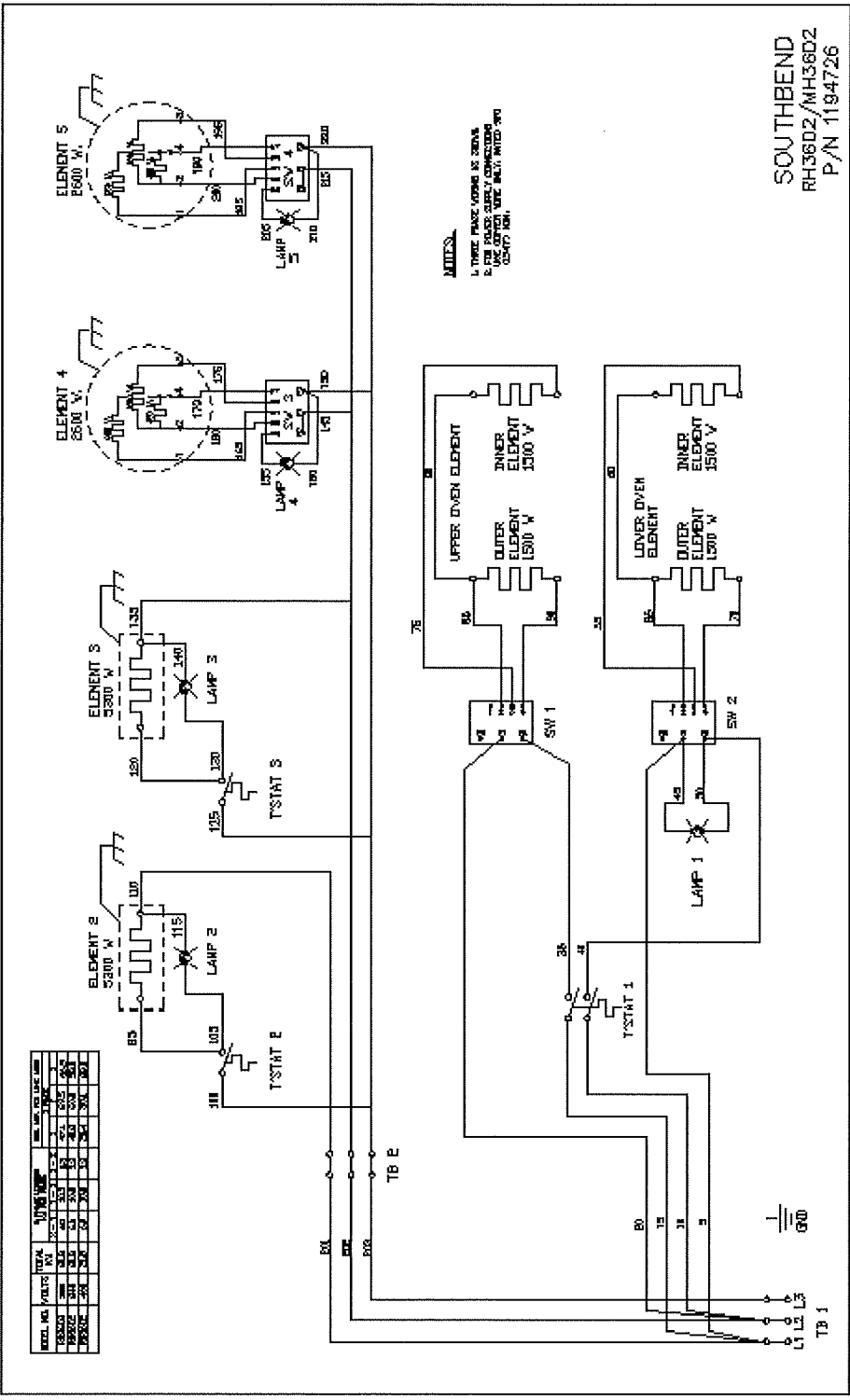

SE36D-HHB WIRING DIAGRAM
 208/240V

SOUTHBEND
 RH36D2/MH36D2
 P/N 1194726

SECTION 5 - SCHEMATICS

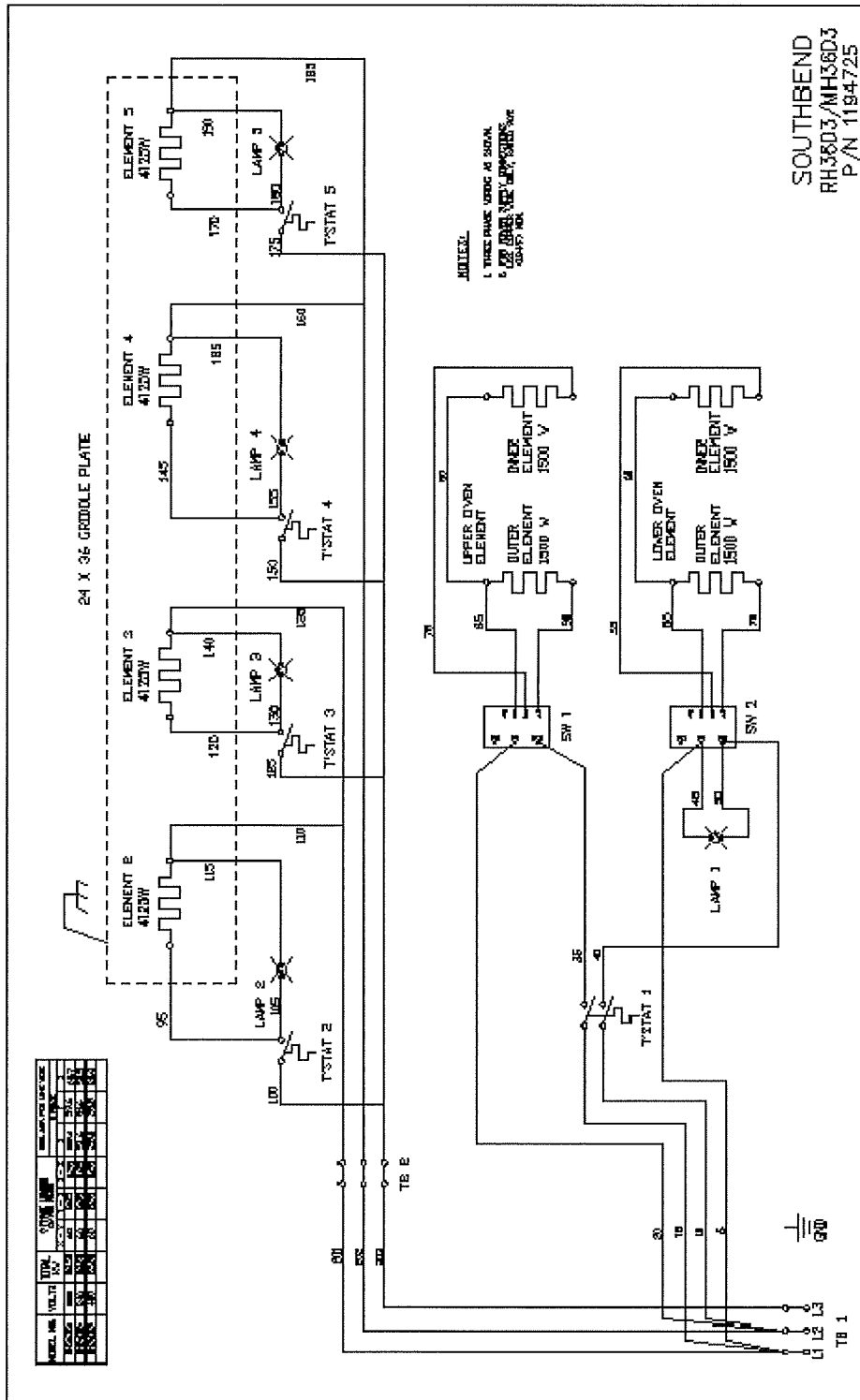

SE36D-ITT WIRING DIAGRAM
 208/240V

SECTION 5 - SCHEMATICS

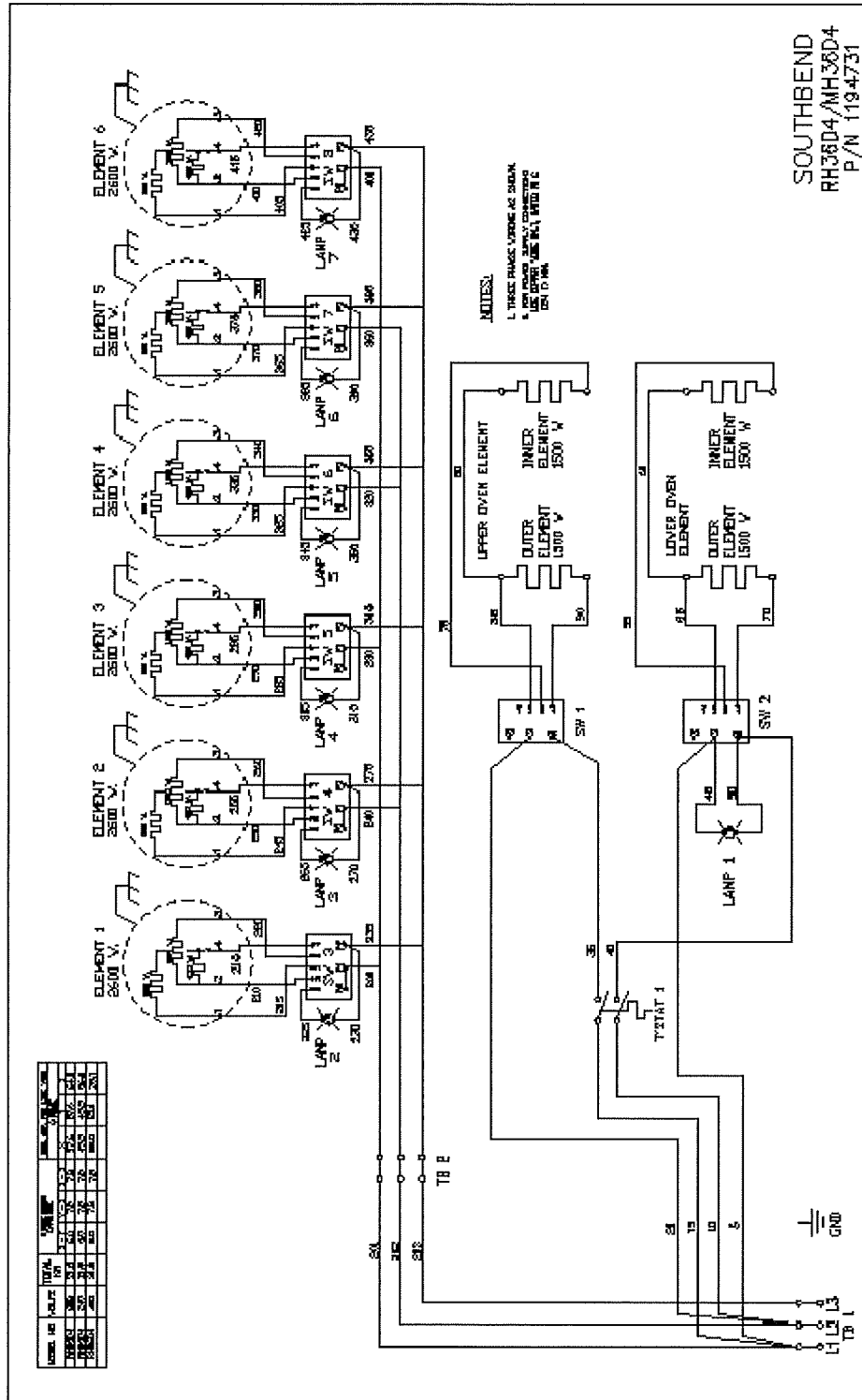

SE36D-BBB WIRING DIAGRAM
 208/240V

SECTION 5 - SCHEMATICS

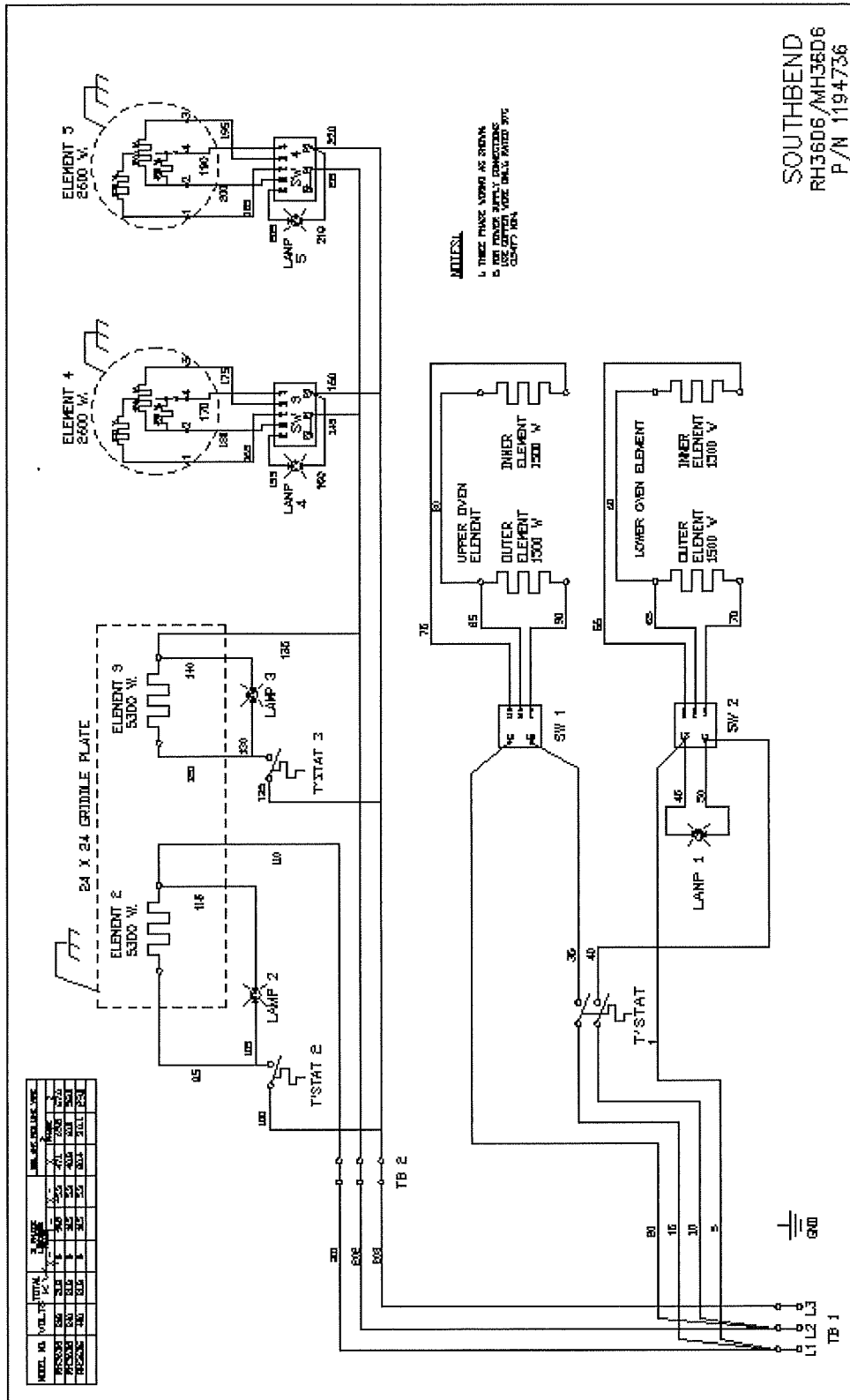

SE36D-TTT WIRING DIAGRAM
208/240V

SECTION 5 - SCHEMATICS

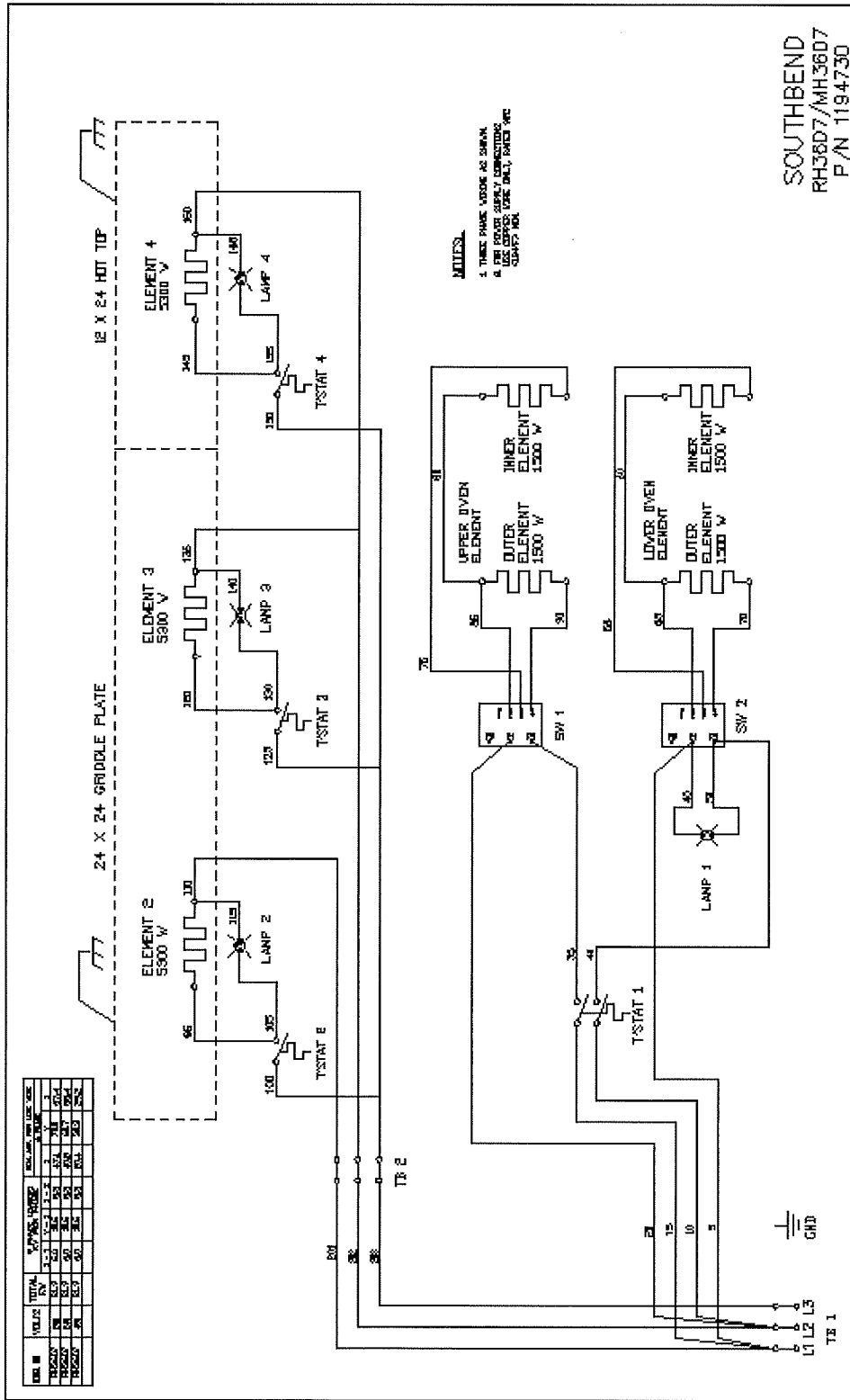

SE36D-TTH WIRING DIAGRAM
 208/240V

SECTION 5 - SCHEMATICS

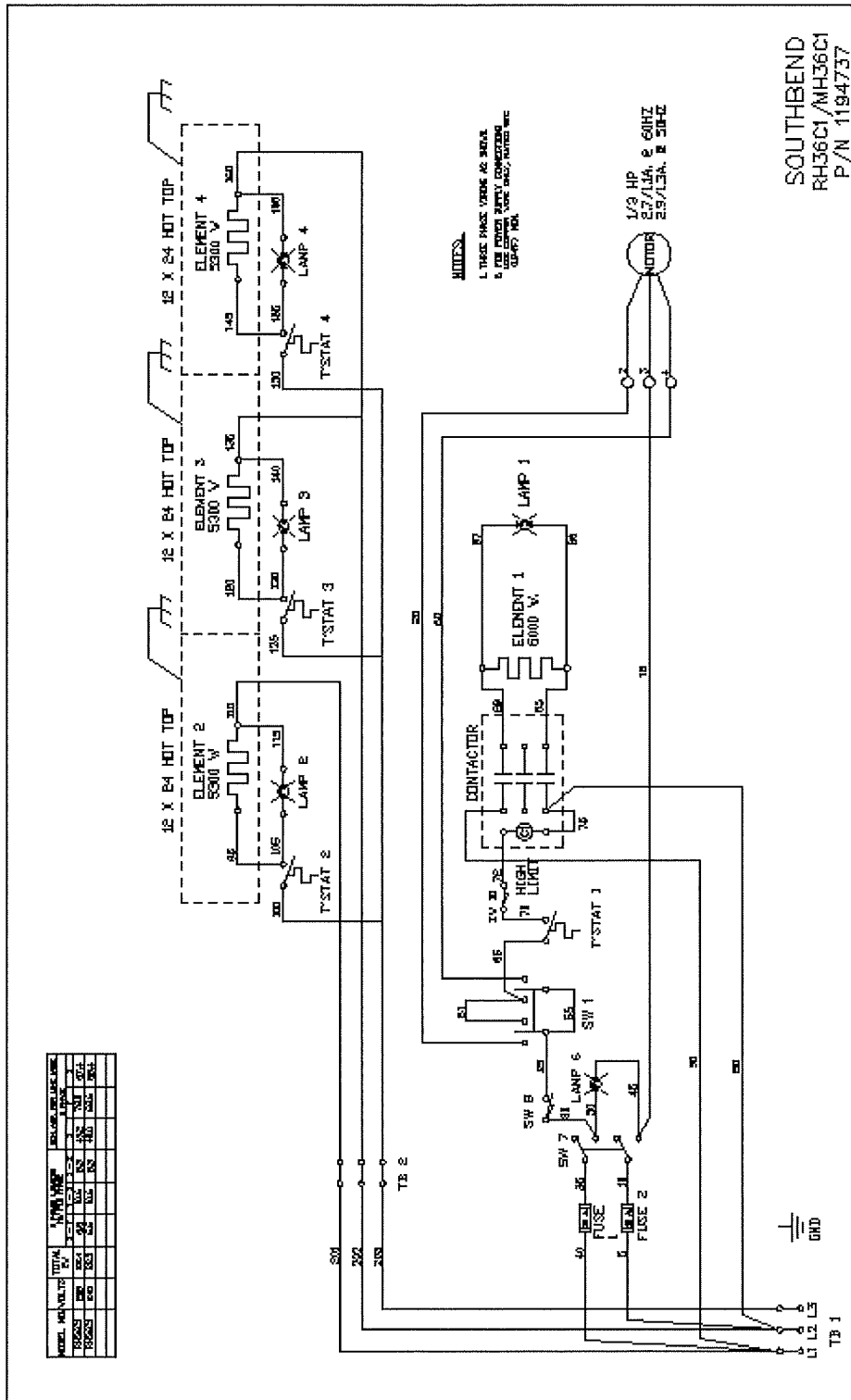

SE36A-HHH WIRING DIAGRAM
 208/240V

SECTION 5 - SCHEMATICS

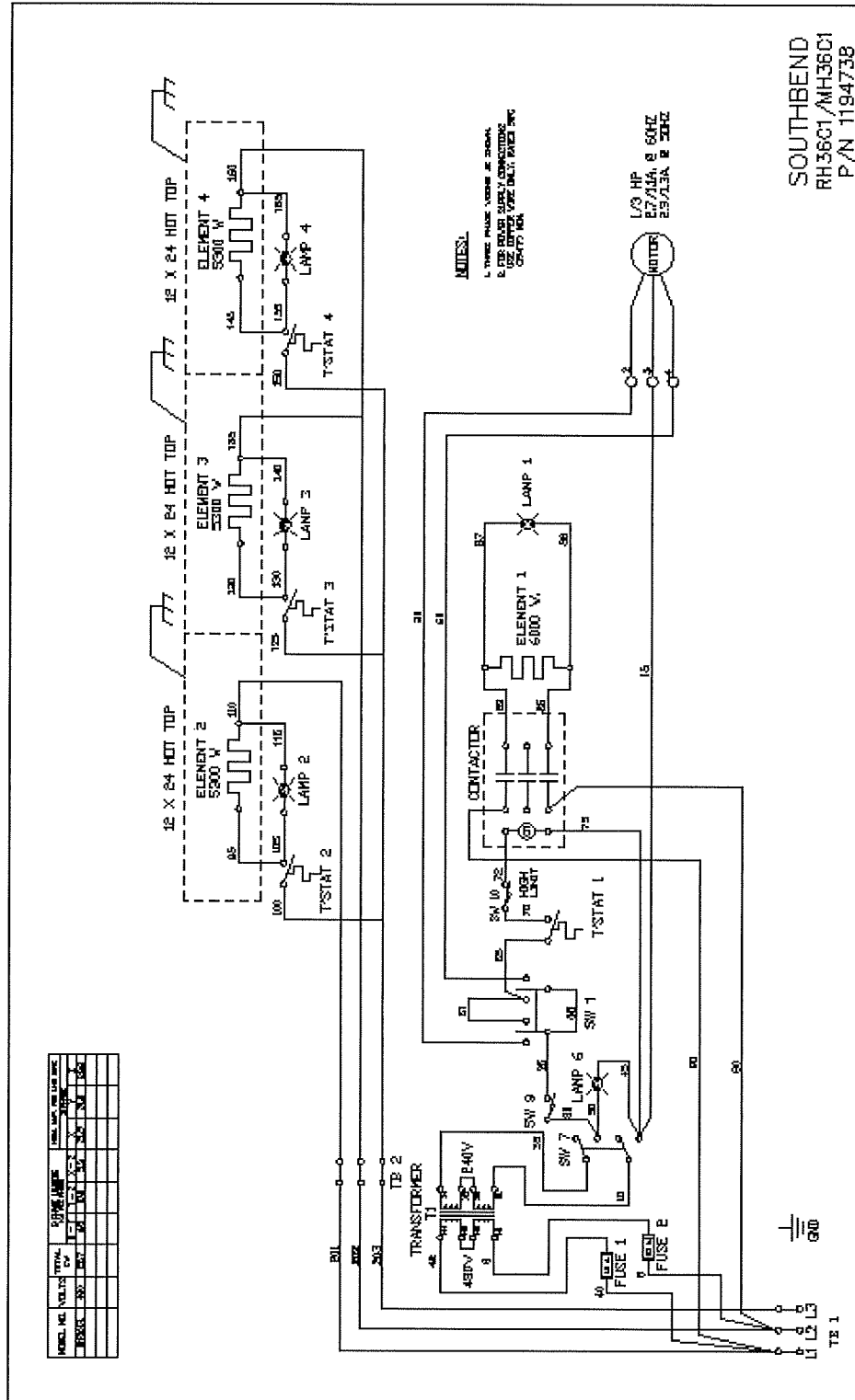

SOUTHBEND
 RH36C1/MH36C1
 P/N 1194738

SE36A-HHH WIRING DIAGRAM
 480V

SECTION 5 - SCHEMATICS

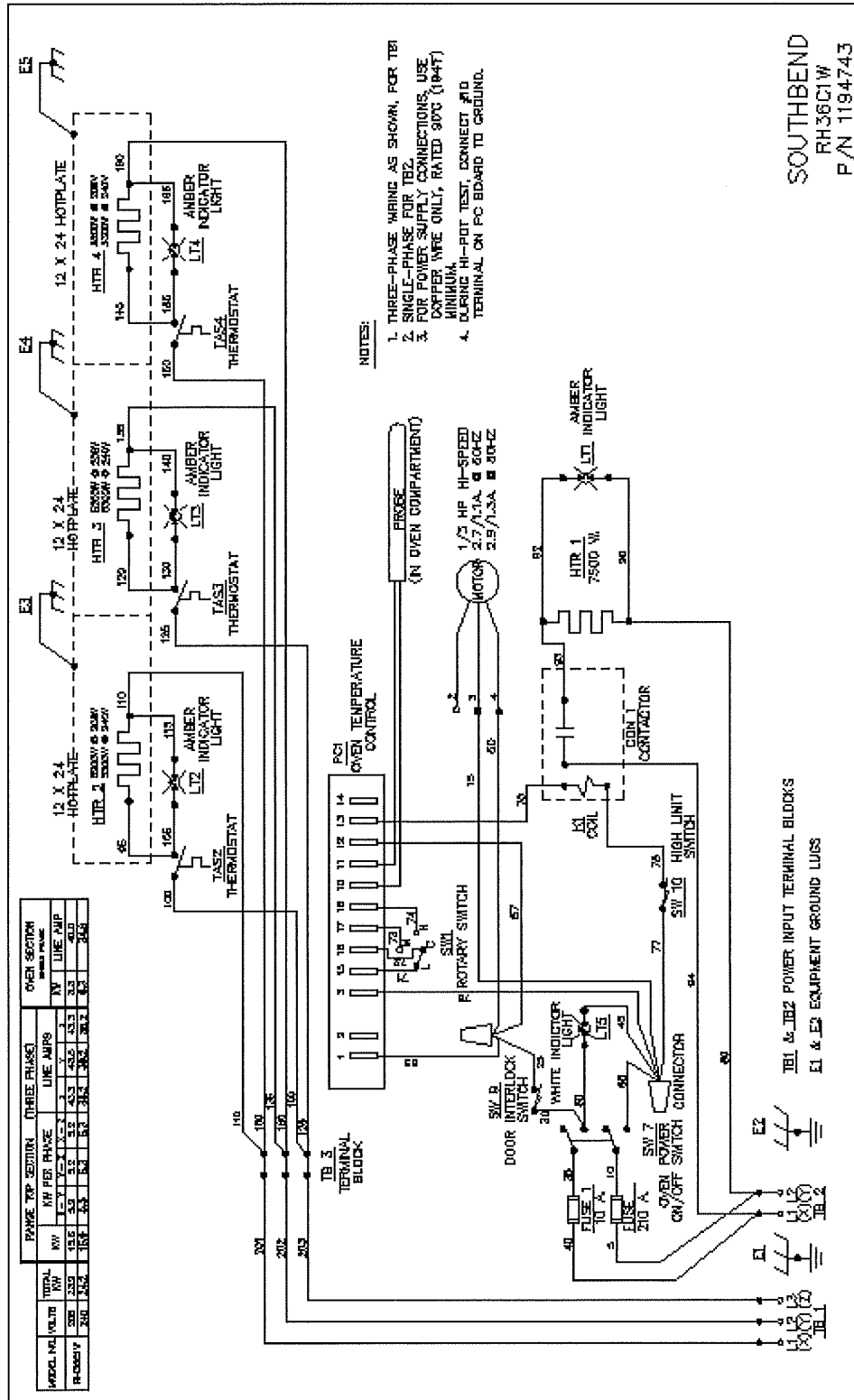

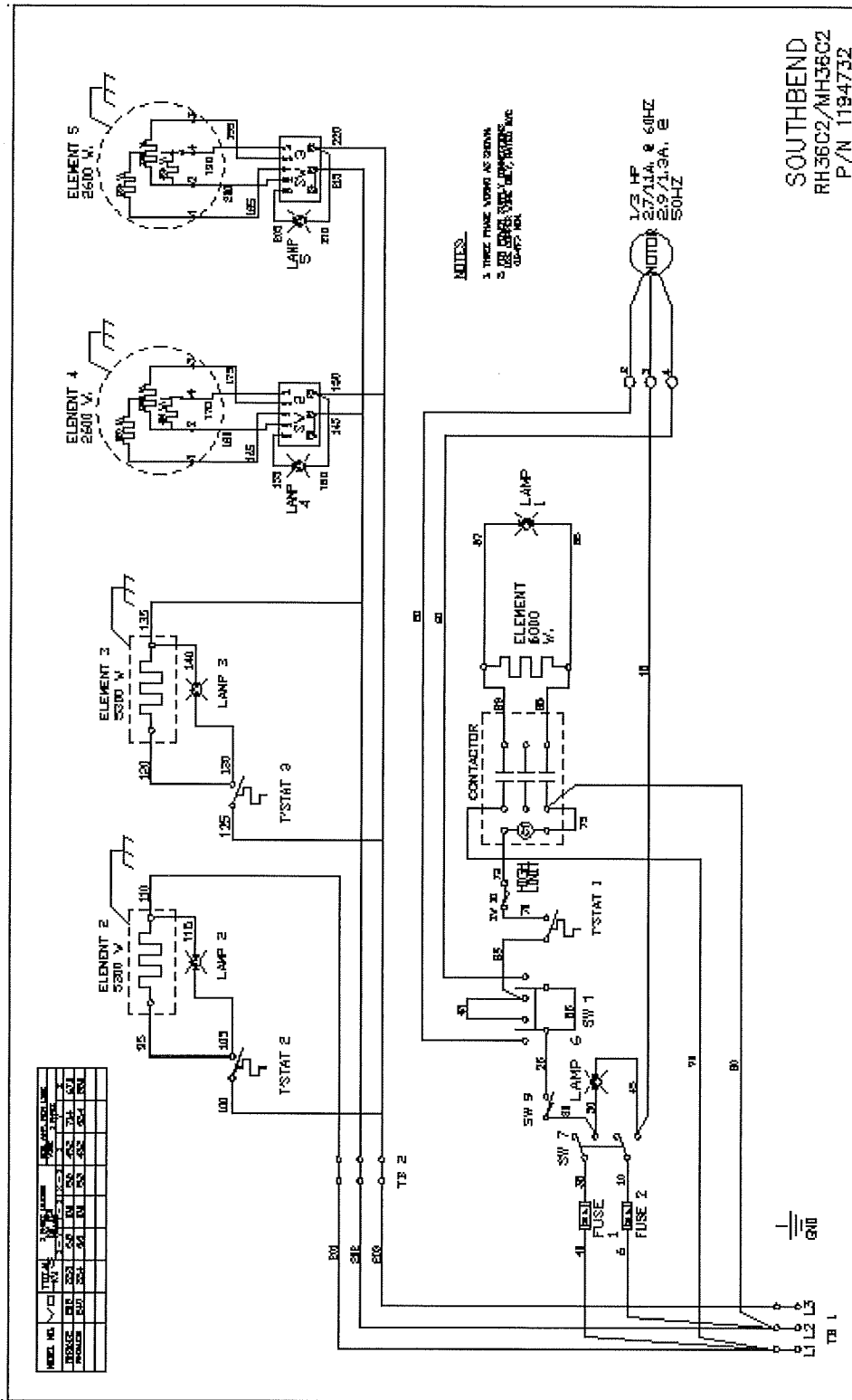

SOUTHBEND
RH36C2/MH36C2
P/N 1194752

SE36A-HHB WIRING DIAGRAM
208/240V

SECTION 5 - SCHEMATICS

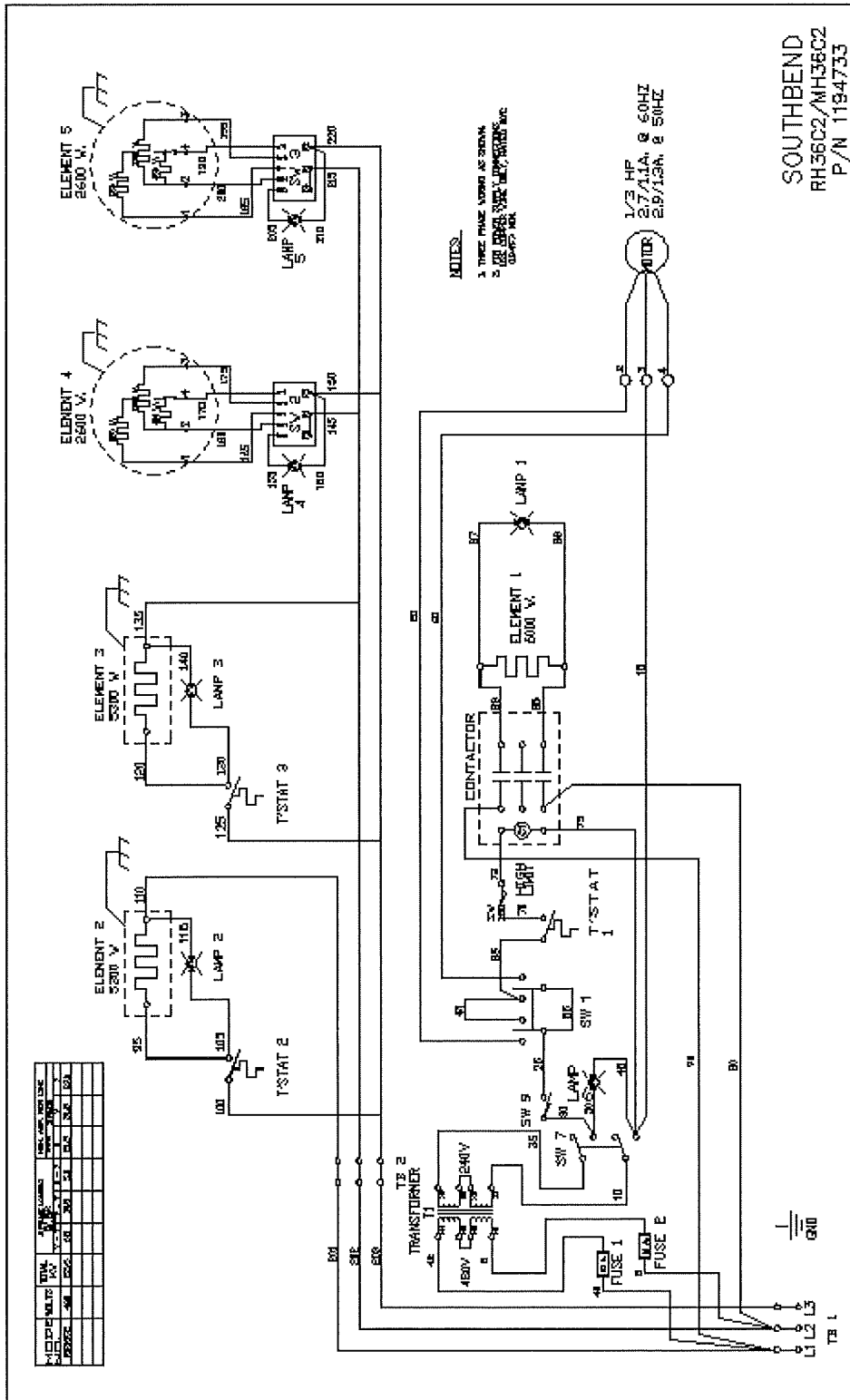

SE36A-HHB WIRING DIAGRAM
480V

SECTION 5 - SCHEMATICS

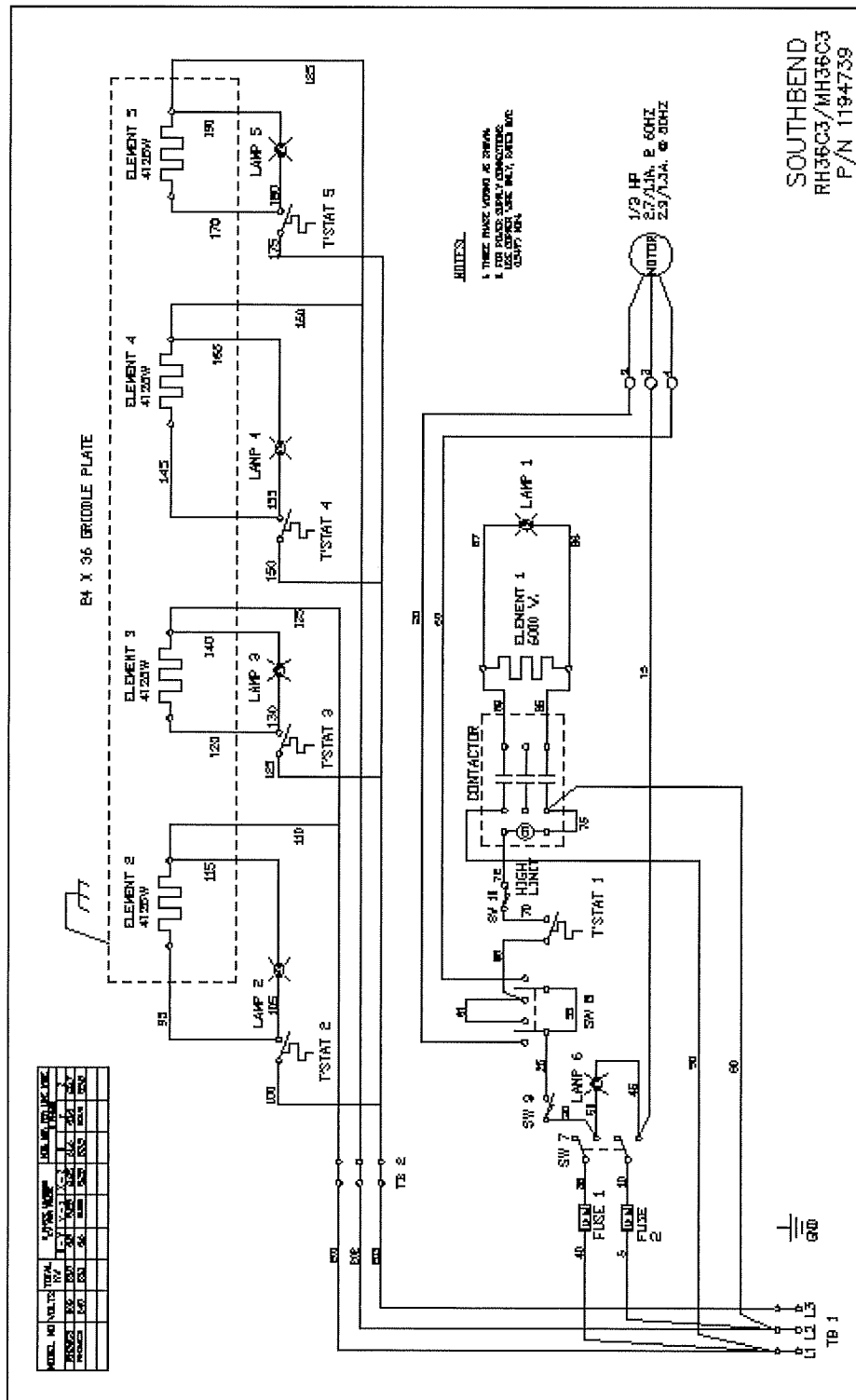

SE36A-ITT WIRING DIAGRAM
208/240V

SECTION 5 - SCHEMATICS

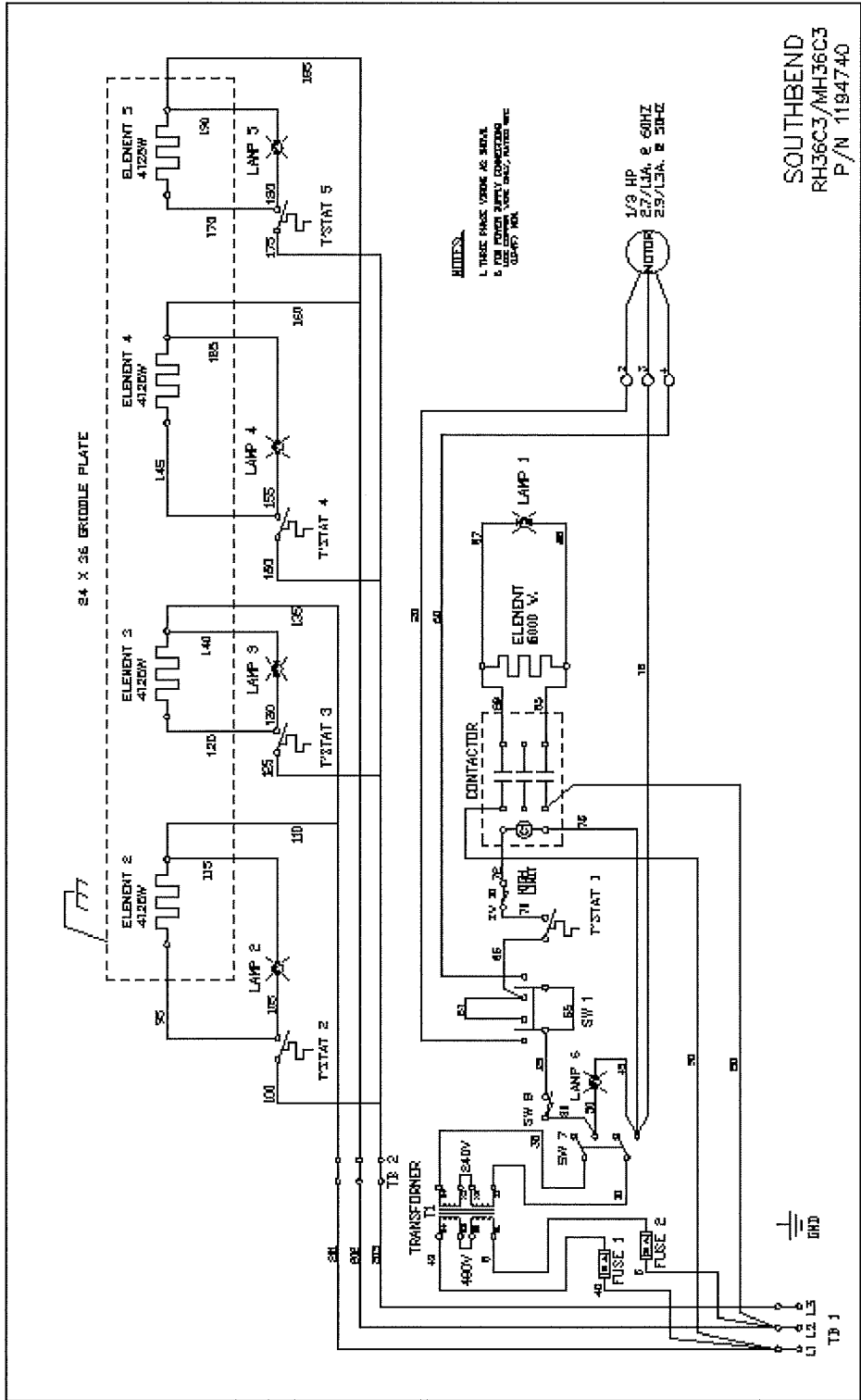

SOUTHBEND
 RH36C3/MH36C3
 P/N 1194740

SE36A-TTT WIRING DIAGRAM
 480V

SECTION 5 - SCHEMATICS

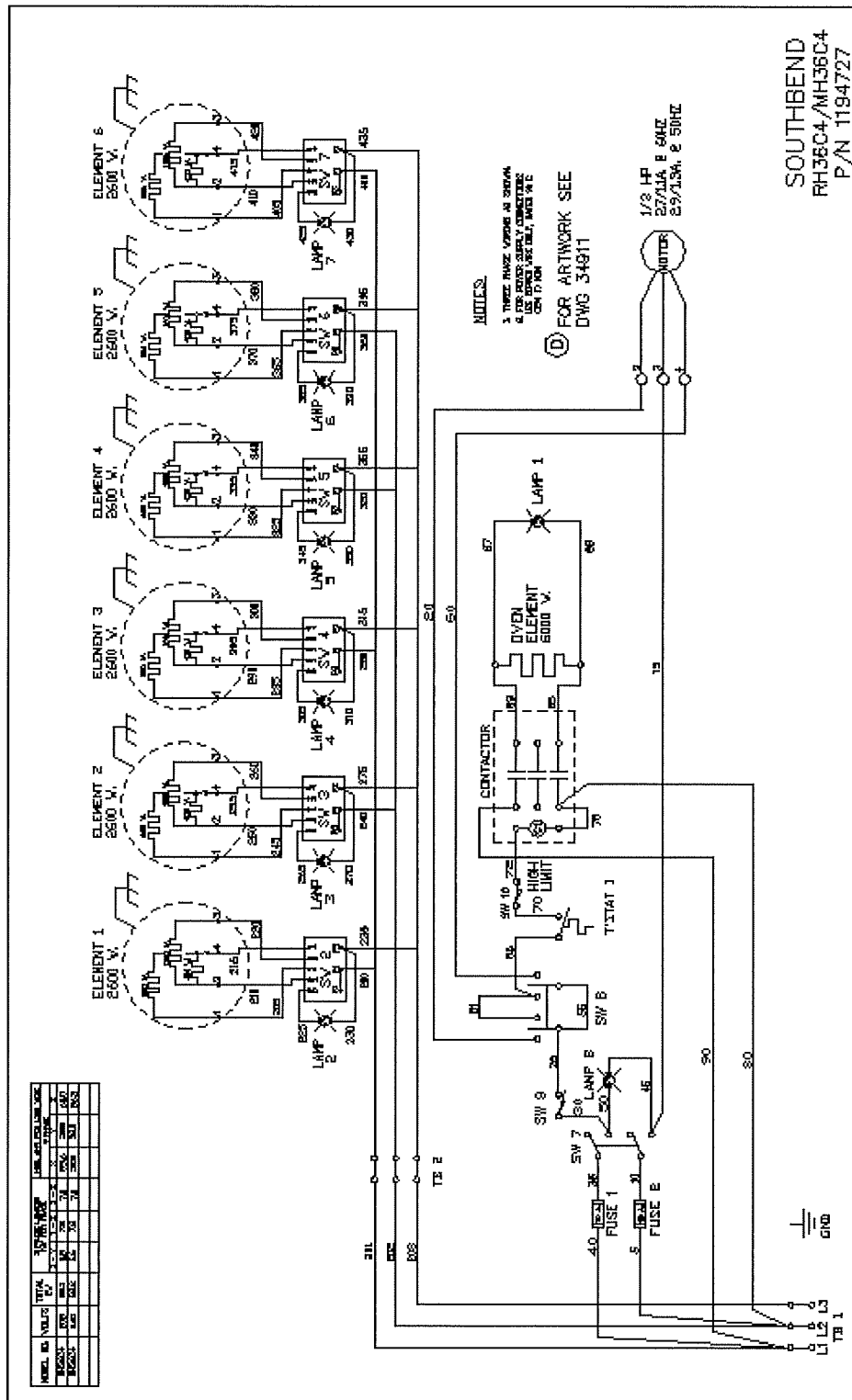

SECTION 5 - SCHEMATICS

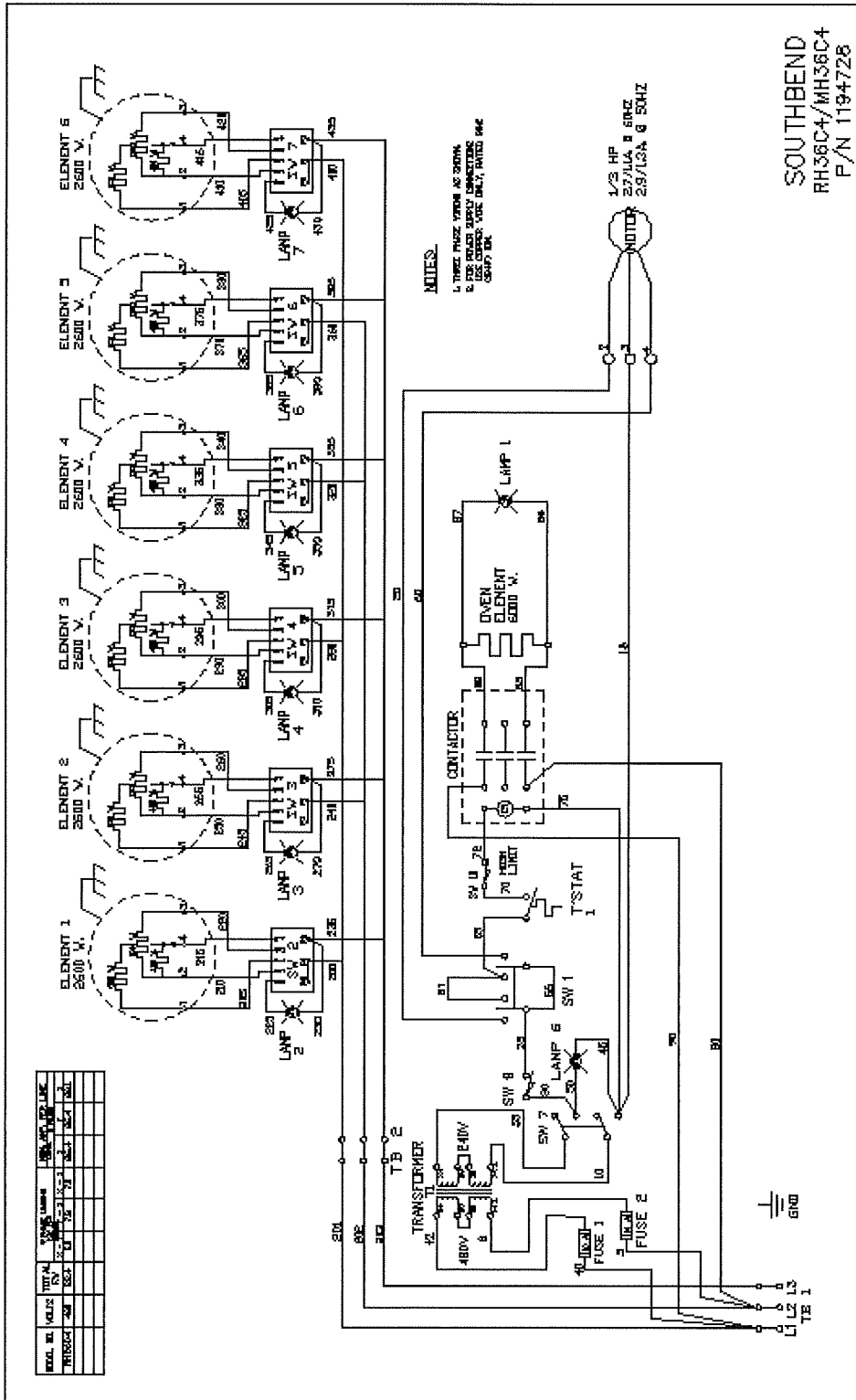

SE36A-BBB WIRING DIAGRAM
 480V

SOUTHBEND
 RH36C4/MH36C4
 P/N 1194726

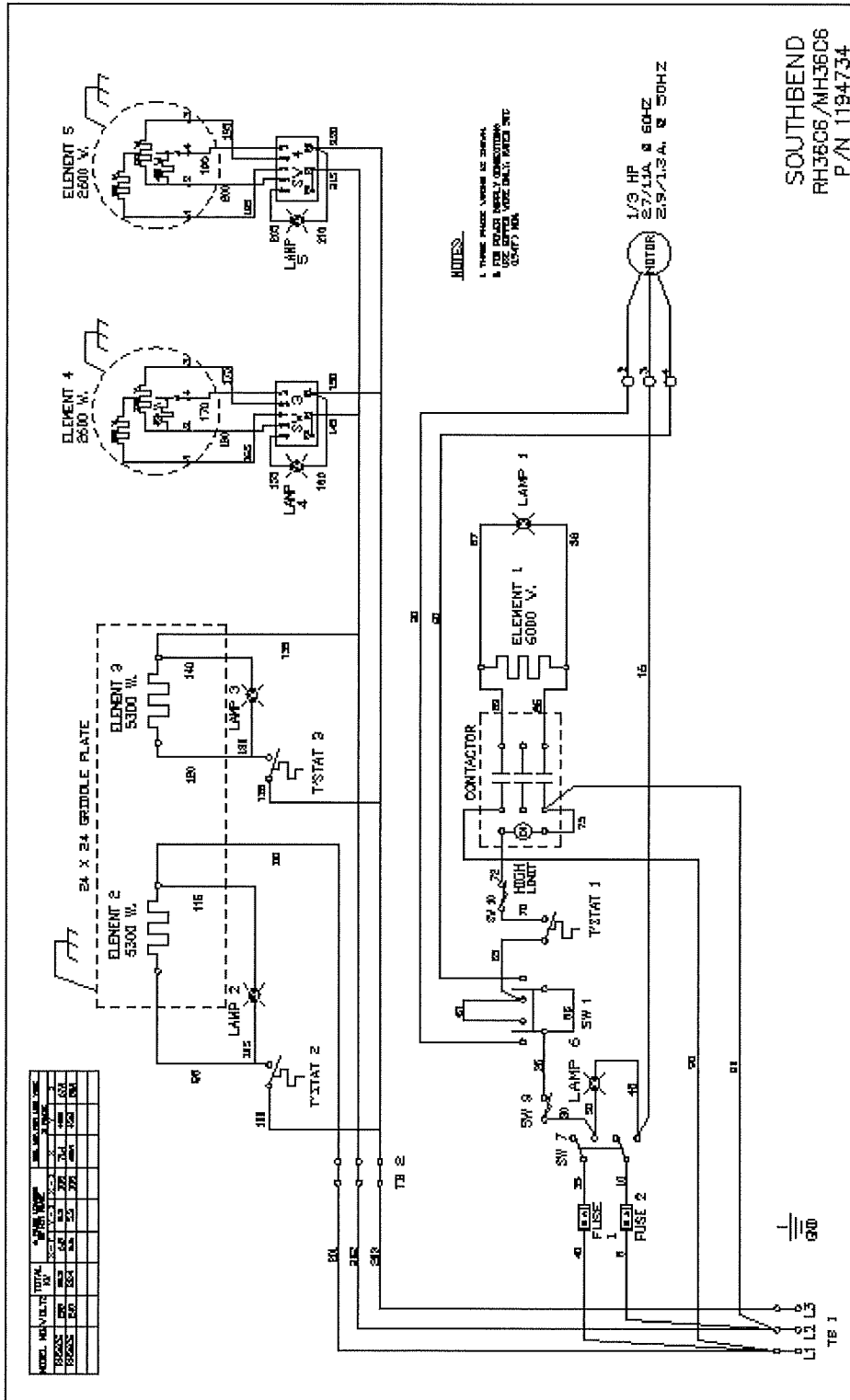

SE36A-TTB WIRING DIAGRAM
208/240V

SECTION 5 - SCHEMATICS

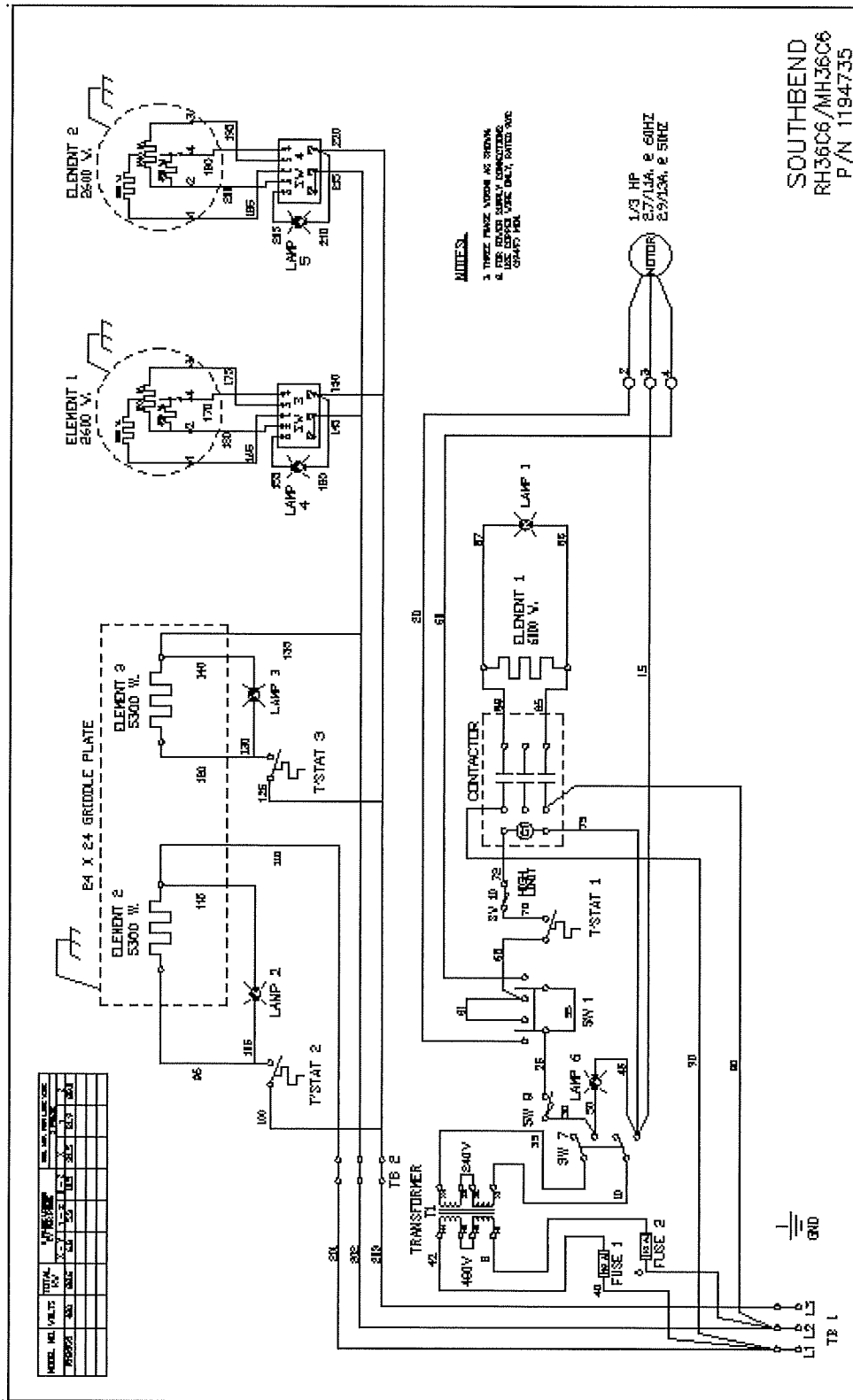

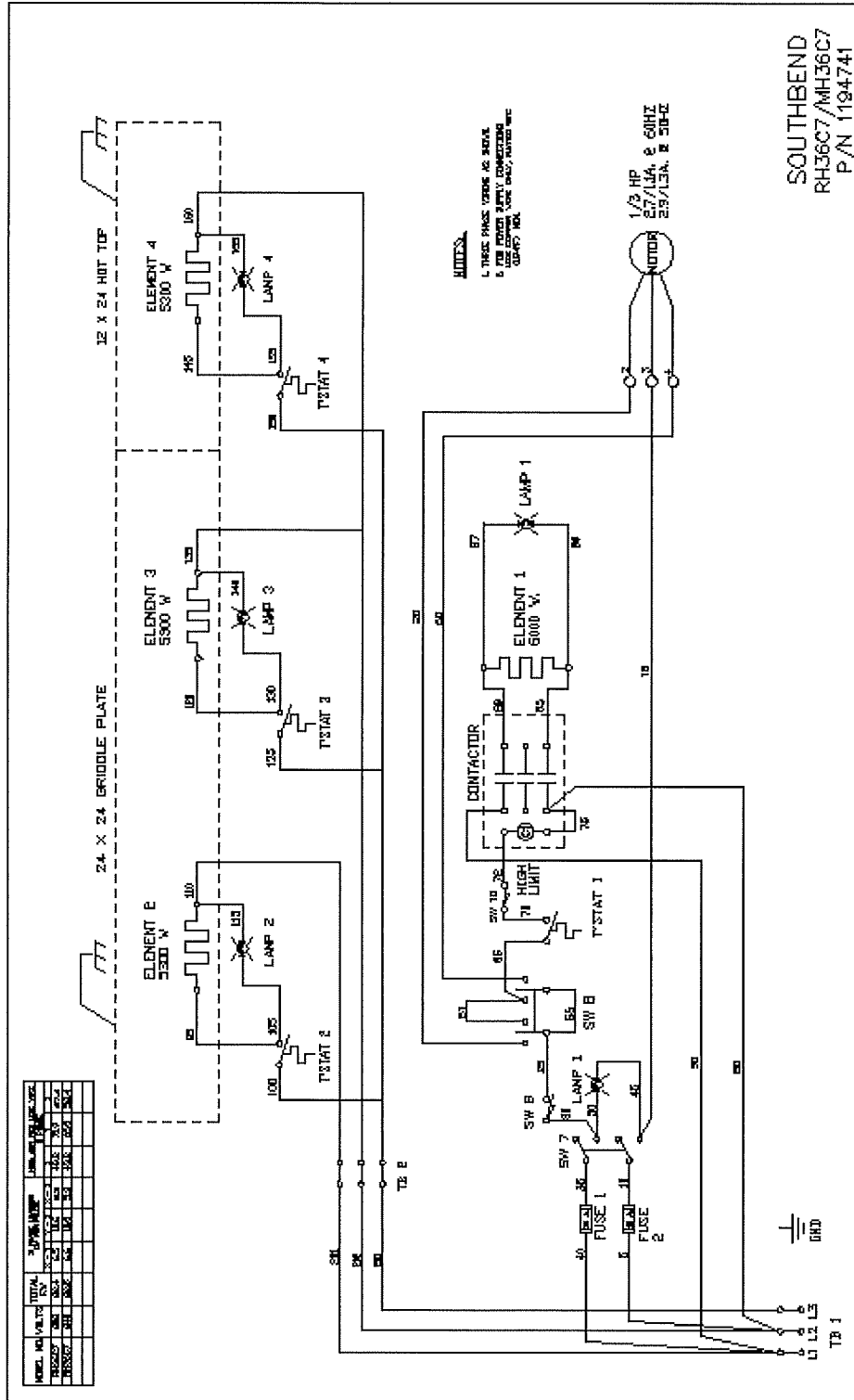

SE36A-TTH WIRING DIAGRAM
 208/240V

SECTION 5 - SCHEMATICS

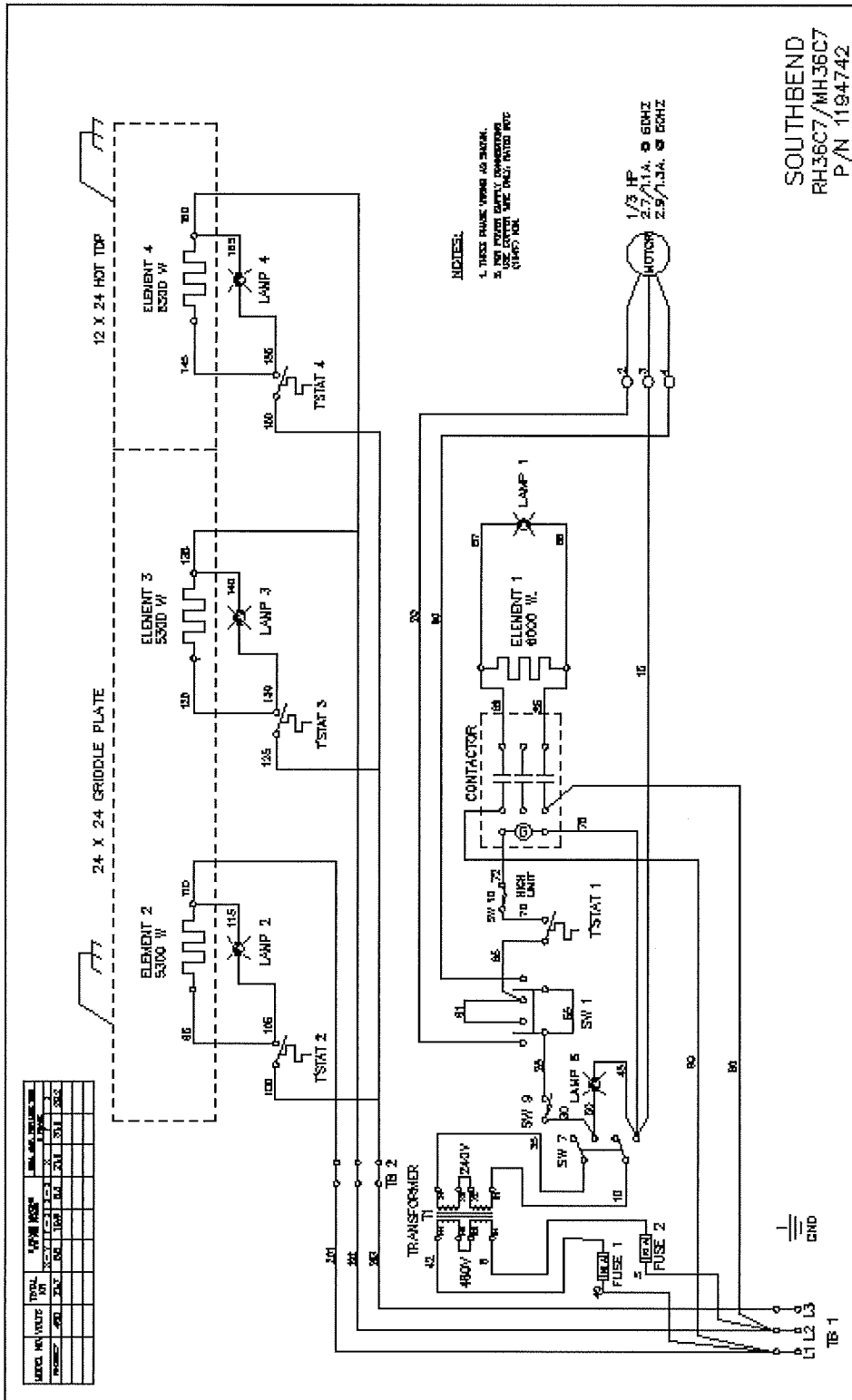

SOUTHBEND
RH36C7/MH36C7
P/N 1194742

SE36A-TTH WIRING DIAGRAM
480V

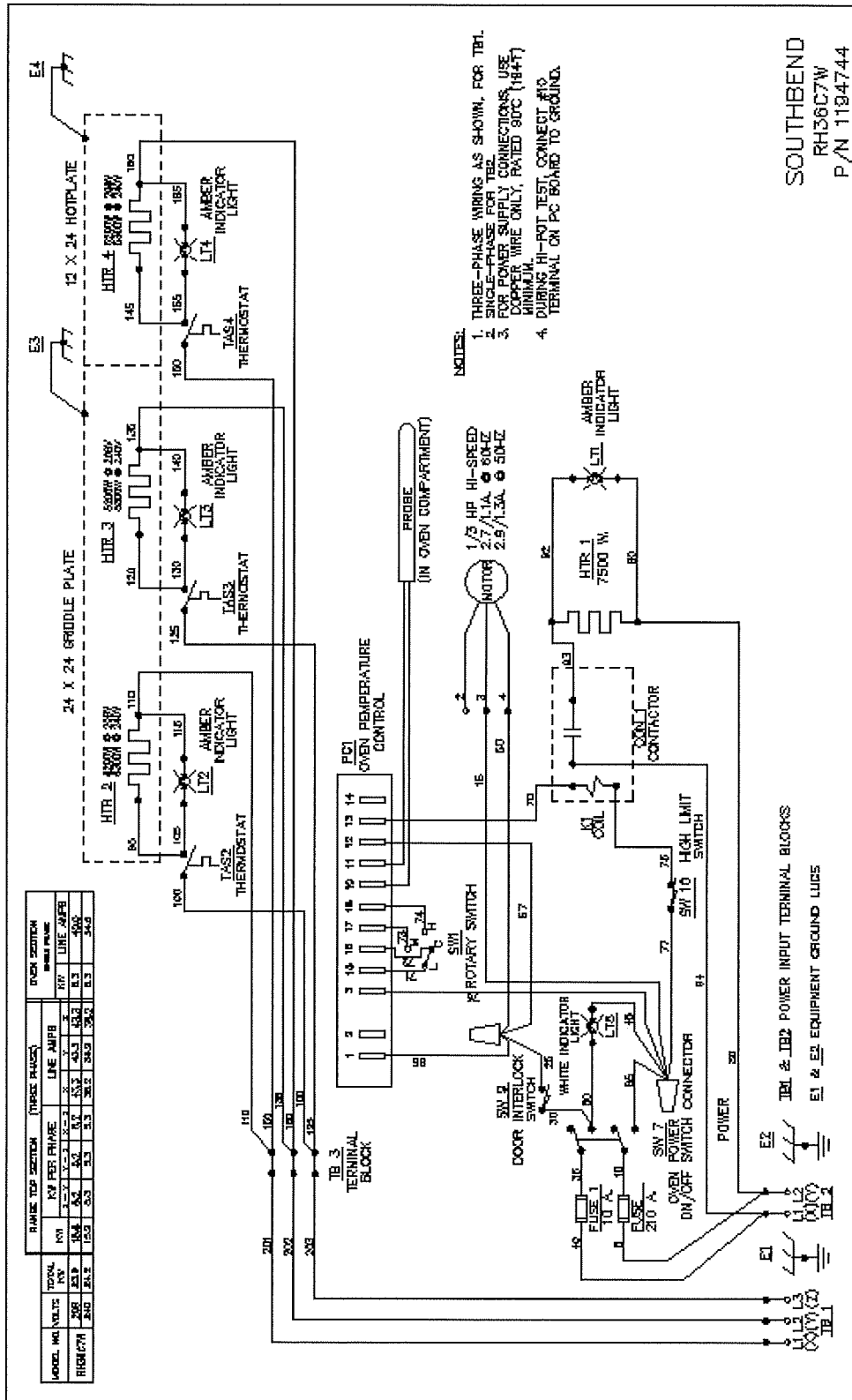

SOUTHBEND
RH36C7W
P/N 1194744

SE36A-TTH WIRING DIAGRAM
208/240V

Oven Range

Model SE36



Commercial Food Equipment Service Association



A product with the Southbend name incorporates the best in durability and low maintenance. We all recognize, however, that replacement parts and occasional professional service may be necessary to extend the useful life of this appliance. When service is needed, contact a Southbend Authorized Service Agency, or your dealer. To avoid confusion, always refer to the model number, serial number, and type of your appliance.



Southbend
1100 Old Honeycutt Road, Fuquay-Varina, NC 27526
www.Southbend nc.com