



IMPORTANT FOR FUTURE REFERENCE
Please complete this information and retain this manual for the life of the equipment:

Model #: _____
Serial #: _____
Date Purchased: _____

Owner's Manual

Radiant Broilers



234R



P32D-3240

⚠ WARNING

Improper installation, adjustment, alteration, service or maintenance can cause property damage, injury or death. Read the installation, operating and maintenance instructions thoroughly before installing or servicing this equipment.

1100 Old Honeycutt Road Fuquay-Varina, North Carolina 27526 USA
www.southbendnc.com

SAFETY PRECAUTIONS

Before installing and operating this equipment, be sure everyone involved in its operation is fully trained and aware of precautions. Accidents and problems can be caused by failure to follow fundamental rules and precautions.

The following symbols, found throughout this manual, alert you to potentially dangerous conditions to the operator, service personnel, or to the equipment.



DANGER

This symbol warns of immediate hazards that will result in severe injury or death.



WARNING

This symbol refers to a potential hazard or unsafe practice that could result in injury or death.



CAUTION

This symbol refers to a potential hazard or unsafe practice that could result in injury, product damage, or property damage.

NOTICE

This symbol refers to information that needs special attention or must be fully understood, even though not dangerous.

 **WARNING**
FIRE HAZARD
FOR YOUR SAFETY

Do not store or use gasoline or other flammable vapors and liquids in the vicinity of this or any other appliance. Keep area around cooking appliances free and clear of combustibles.

Purchaser of equipment must post in a prominent location detailed instructions to be followed in the event the operator smells gas. Obtain the instructions from the local gas supplier.

 **WARNING**
BURN HAZARD

Contact with hot surfaces will cause severe burns. Always use caution when operating cooking appliances.

 **WARNING**
EXPLOSION AND ASPHYXIATION HAZARD

In the event a gas odor is detected, shut down equipment at the main gas shut-off valve and immediately call the emergency phone number of your gas supplier.

Improper ventilation can result in headaches, drowsiness, nausea, and could result in death. Do not obstruct the flow of combustion and ventilation air to and from cooking appliances.

 **WARNING**
ELECTRIC SHOCK HAZARD

For appliances that use electric power, disconnect the power to the appliance before cleaning. Do not remove panels that require tools to remove. Disconnect power before opening kick panel below oven.

NOTICE

This appliance is intended for commercial use, and is only for professional use. It shall be used by trained, qualified people.

Warranty will be void if service work is performed by other than a qualified technician, or if other than genuine Southbend replacement parts are installed.

Give this Owner's Manual and important papers to the proper authority to retain for future reference.

Congratulations! You have purchased one of the finest pieces of heavy-duty commercial cooking equipment on the market.

You will find that your new equipment, like all Southbend equipment, has been designed and manufactured to meet the toughest standards in the industry. Each piece of Southbend equipment is carefully engineered and designs are verified through laboratory tests and field installations. With proper care and field maintenance, you will experience years of reliable, trouble-free operation. **For best results, read this manual carefully.**

RETAIN THIS MANUAL FOR FUTURE REFERENCE.

Table of Contents

Specifications	5
Installation	9
Operation	15
Cleaning	21
Adjustments	23
Troubleshooting	27

Read these instructions carefully before attempting installation. Installation and initial startup should be performed by a qualified installer. Unless the installation instructions for this product are followed by a qualified service technician (a person experienced in and knowledgeable with the installation of commercial gas an/or electric cooking equipment) then the terms and conditions on the Manufacturer's Limited Warranty will be rendered void and no warranty of any kind shall apply.

In the event you have questions concerning the installation, use, care, or service of the product, contact:

Southbend
1100 Old Honeycutt Road
Fuquay-Varina, North Carolina 27526 USA

The serial plate is located on the interior side of the lower front panel, as shown below.

The serial plate is located on the interior side of the lower front panel, as shown below.

Figure 1

Broiler Serial Plate Location

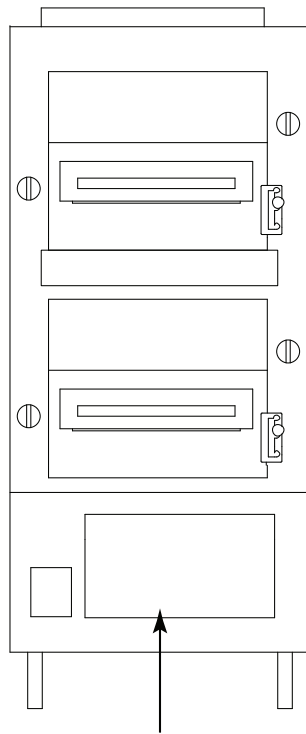

The serial plate is located behind the access panel.
To remove the panel, lift it straight up and pull it out at the bottom.

Figure 2

Oven Serial Plate Locations

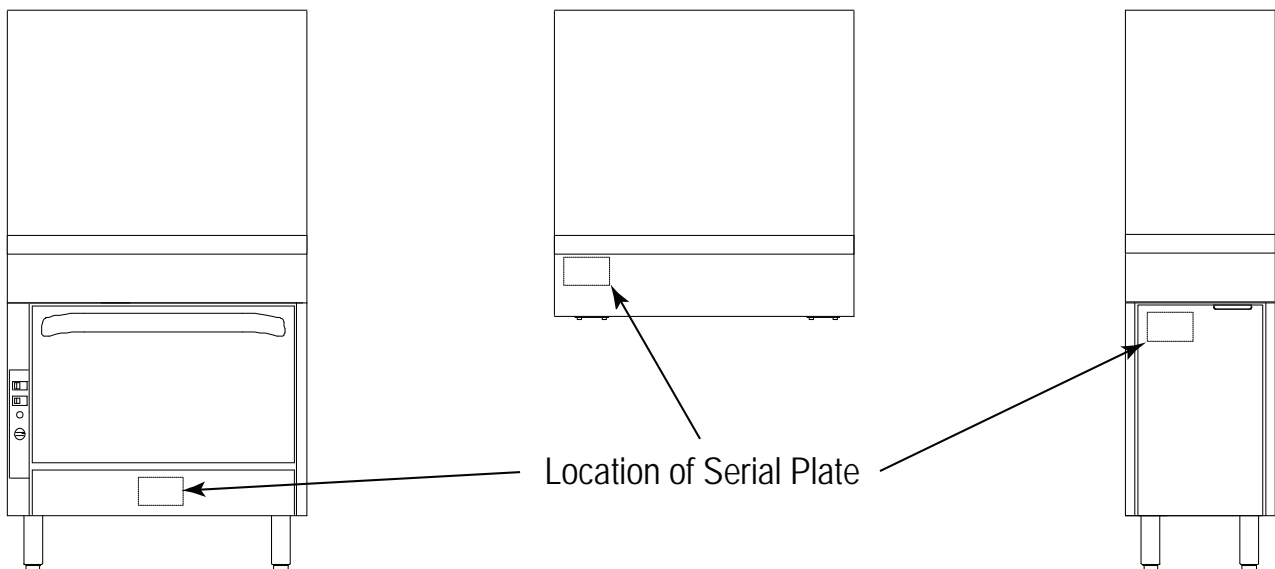

Location of Serial Plate

SPECIFICATIONS

NOTICE

Local codes regarding installation vary greatly from one area to another. The National Fire Protection Association, Inc. states in its NFPA 96 latest edition that local codes are the “authority having jurisdiction” when it comes to installation requirements for equipment. Therefore, installations should comply with all local codes.

Southbend reserves the right to change specifications and product design without notice. Such revisions do not entitle the buyer to corresponding changes, additions, or replacements for previously purchased equipment. This product is intended for commercial use only, not for household use.

The installation must conform with local codes, or in the absence of local codes, with the *National Fuel Gas Code, ANSI Z223.1, Natural Gas Installation Code, CAN/CGA-B149.1*, or the *Propane Installation Code CAN/CGA-B149.2*, as applicable, including:

1. The appliance and its individual shutoff valve must be disconnected from the gas supply piping system during any pressure testing of that system at test pressures in excess of 1/2 psi (3.45 kPa).
2. The appliance must be isolated from the gas supply piping system by closing its individual manual shutoff valve during any pressure testing of the gas supply piping system at test pressures equal to or less than 1/2 psi (3.45 kPa).

CLEARANCES

WARNING

MINIMUM CLEARANCES FROM COMBUSTIBLE CONSTRUCTION

Minimum clearance from combustible surfaces is 6” on the sides and back. Minimum clearance from non-combustible surfaces is 0” on the sides and back.

Adequate clearance must be provided in the aisle in front of the broiler to permit operation (including pulling out of broiler racks and removal of the drippings drawers), as well as for servicing. No additional clearance is required for servicing as the broiler is serviceable from the front.

The high-temperature flue products flow out through the top of the broiler. Installation under a vented hood is recommended.

Units have 6” legs or casters, and may be installed on combustible floors.

VENTILATION

WARNING

Improper ventilation can result in personal injury or death. Ventilation which fails to properly remove flue products can cause headaches, drowsiness, nausea, or could result in death.

All units must be installed in such a manner that the flow of combustion and ventilation air is not obstructed. Provisions for adequate air supply must be provided. Do not obstruct the front of the unit at the bottom where the air filter is located or below the oven door as combustion air enters at these locations.

NOTICE

Proper ventilation is the owner's responsibility. Any problem due to improper ventilation will not be covered by the warranty.

Be sure to inspect and clean the ventilation system according to the ventilation equipment manufacturer's instructions.

If a ventilation canopy is used, it is recommended that the canopy extend 152.4 mm (6"), past the appliance and that the bottom edge be located 1981 mm (6'6") from the floor. Filters should be installed at an angle of 45° or more from the horizontal. This position prevents dripping grease and facilitates collecting the run-off grease in a drip pan, unusually installed with a filter.

A strong exhaust fan tends to create a vacuum in the room and may interfere with burner performance or may extinguish pilot flames. Fresh air openings approximately equal to the fan area will relieve such a vacuum. The exhaust fan should be installed at least 609.6 mm (24"), above the vent opening at the top of the unit.

NOTICE

Due to the variety of problems encountered by outside weather conditions, venting by canopies or wall fans is preferred over any type of direct venting.

If the unit is connected directly to an outside flue, a CSA design certified down draft diverter must be installed.

In case of unsatisfactory performance on any appliance, check the appliance with the exhaust fan turned OFF. Do this only long enough to check whether doing so corrects any problems with equipment performance. Then turn the exhaust fan back on and let it run to remove any exhaust that may have accumulated during the test.

FREE STANDING BROILERS

GAS SUPPLY

The broiler is design-certified for operation on natural or propane gases. The broiler is shipped configured and adjusted for the type of gas specified by the purchaser, which is indicated on the serial plate (see Figure 1). Connect the broiler ONLY to the type of gas for which it is configured and adjusted.

The broiler has a 3/4" rear gas connection with a male NPT connector and an internal shut-off valve. Minimum supply pressure is 7" W.C. for natural gas, 11" W.C. for propane. The broiler has an internal pressure regulator that is set for 4" W.C. pressure for natural gas or 10" W.C. pressure for propane gas. If using a flexible-hose gas connection, the inside diameter of the hose must not be smaller than the connector on the broiler, and must comply with ANSI Z21.69 (or CSA 6.16). Provide an adequate means of restraint to prevent undue strain on the gas connection.

If applicable, the vent line from the gas appliance pressure regulator shall be installed to the outdoors in accordance with local codes, or in the absence of local codes, with the National Fuel Gas Code, ANSI Z223.1/NFPA 54 or the Natural Gas and Propane Installation Code CSA B149.1, as applicable.

An adequate gas supply is imperative. Undersized or low pressure lines will restrict the volume of gas required for satisfactory performance. Fluctuations of more than 25% on natural gas or 10% on propane gas will create problems and affect burner operating characteristics. A 1/8" pressure tap is located adjacent to the pressure regulator to measure the pressure. The supply line to the broiler should have an inside diameter no smaller than 3/4".

OVEN BASE BROILER

ELECTRICITY SUPPLY

Broilers with convection-oven bases with optional electronic ignition require electric power (50Hz or 60Hz single-phase AC). 120V models have a 7-foot (2134 mm) power cord with a grounded plug (1.0 amps for “D” Models and 4.8 amps for “A” Models). The 208/240V models have a terminal block for connection to a single-phase 208/240V source (1.0 amps for “D” Models and 2.6 amps for the “A” Models).

The appliance, when installed, must be electrically grounded in accordance with local codes, or in the absence of local codes, with the *National Electrical Code, ANSI/NFPA 70, or the Canadian Electrical Code, CSA C22.2*, as applicable. An electrical diagram is located on the rear of the oven, near the motor.

GAS SUPPLY

Southbend cooking equipment is design-certified for operation on natural or propane gases. Southbend cooking equipment is shipped configured and adjusted for the type of gas specified by the purchaser, which is indicated on the serial plate (see Figure 1 and Figure 2). Connect the Southbend cooking equipment ONLY to the type of gas for which it is configured and adjusted.

Oven base broiler has a 1-1/4” front gas manifold that can be coupled to adjacent section(s). Sections can be ordered with an optional 1” rear gas connection with a male NPT connector. Minimum supply pressure is 17.436 mbar (7” W.C.) for natural gas, 27.4 mbar (11” W.C.) for propane. An external pressure regulator and shut off valve must be provided. If using a flexible-hose gas connection, the I.D. of the hose must not be smaller than the connector on the unit and must comply with ANSI Z21.69. Provide an adequate means of restraint to prevent undue strain on the gas connection.

If applicable, the vent line from the gas appliance pressure regulator shall be installed to the outdoors in accordance with local codes, or in the absence of local codes, with the *National Fuel Gas Code, ANSI Z223.1, Natural Gas Installation Code, CAN/CGA-B149.1, or the Propane Installation Code CAN/CGA-B149.2, as applicable.*

An adequate gas supply is imperative. Undersized or low pressure lines will restrict the volume of gas required for satisfactory performance. Fluctuations of more than 25% on natural gas or 10% on propane gas will create problems and affect burner operating characteristics. A 1/8” pressure tap is located on the manifold to measure the manifold pressure. The supply line to the sectional unit should be no smaller than the inside diameter of the pipe on the equipment to which it is connected.

To ensure optimum unit operation the pressure in the main supply line, when all units are operating simultaneously, should not drop below 17.436 mbar (7” W.C.) for natural gas and 27.4 mbar (11” W.C.) for propane gas.

Figure 3

Free Standing Broiler Pressure Tap Location

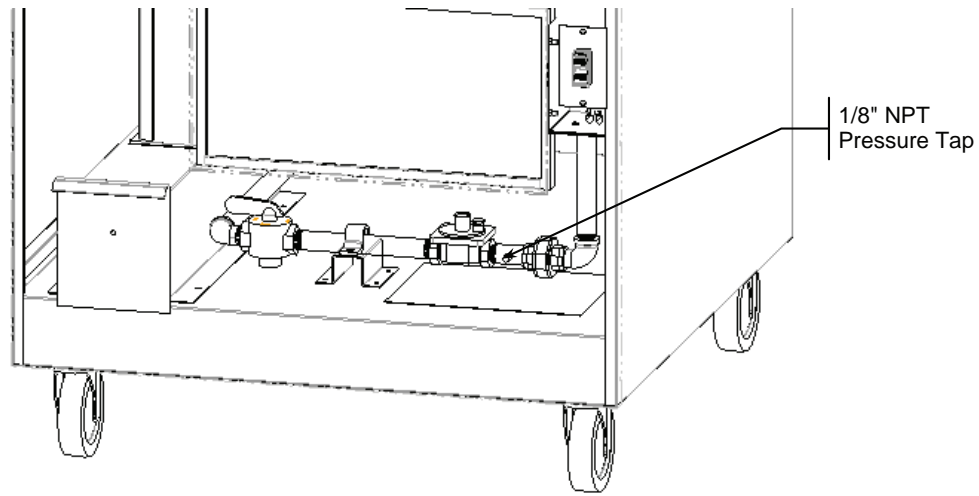
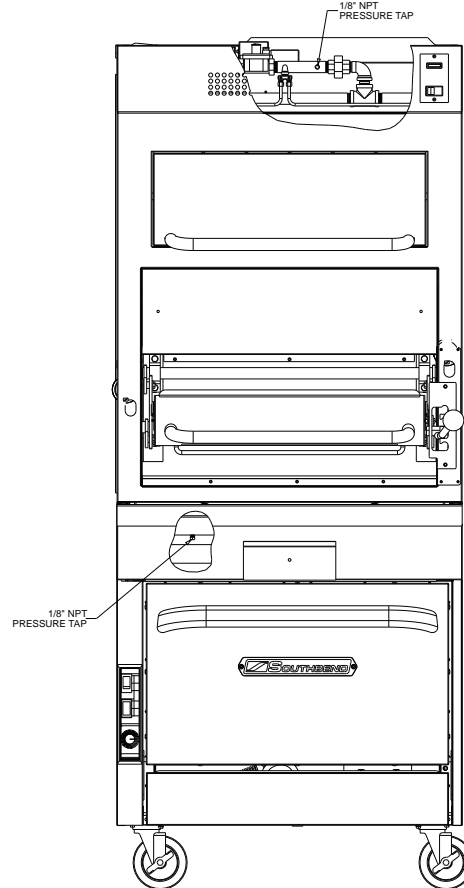

Figure 4

Oven Base Broilers Pressure Tap Locations



INSTALLATION

NOTICE

These installation procedures must be followed by qualified personnel or warranty will be void.

Local codes regarding installation vary greatly from one area to another. The National Fire Protection Association, Inc. states in its NFPA 96 latest edition that local codes are the “authority having jurisdiction” when it comes to installation requirements for equipment. Therefore, installations should comply with all local codes.

The installation must conform with local codes, or in the absence of local codes, with the *National Fuel Gas Code, ANSI Z223.1, Natural Gas Installation Code, CAN/CGA-B149.1*, or the *Propane Installation Code CAN/CGA-B149.2*, as applicable, including:

1. The appliance and its individual shutoff valve must be disconnected from the gas supply piping system during any pressure testing of that system at test pressures in excess of 1/2 psi (3.45 kPa) or 35 mbar (14” W.C).
2. The appliance must be isolated from the gas supply piping system by closing its individual manual shutoff valve during any pressure testing of the gas supply piping system at test pressures equal to or less than 1/2 psi (3.45 kPa) 35 mbar (14” W.C).

NOTICE

EXHAUST FANS AND CANOPIES: It is recommended that the Southbend equipment be installed under a ventilation hood. Consult local codes for proper installation of hoods. Proper ventilation is the owner’s responsibility. Any problem due to improper ventilation will not be covered by warranty.

NOTICE

In the Commonwealth of Massachusetts all gas appliances vented by either mechanical systems or ventilation hoods shall comply with 248 CMR interlocking requirements.

STEP 1: UNPACKING

IMMEDIATELY INSPECT FOR SHIPPING DAMAGE

All containers should be examined for damage before and during unloading. The freight carrier has assumed responsibility for its safe transit and delivery. If damaged equipment is received, either apparent or concealed, a claim must be made with the delivering carrier.

Apparent damage or loss must be noted on the freight bill at the time of delivery. The freight bill must then be signed by the carrier representative (Driver). If the bill is not signed, the carrier may refuse the claim. The carrier can supply the necessary forms.

A request for inspection must be made to the carrier within 15 days if there is concealed damage or loss that is not apparent until after the equipment is uncrated. The carrier should arrange an inspection. Be certain to hold all contents plus all packing material.

For each section, do the following:

1. Cut the banding straps and remove the corrugated cardboard surrounding the Southbend product. Do not remove any tags or labels attached to the equipment until the unit is installed and working properly.
2. Cut the banding strap holding the equipment to the wooden skid.
3. Unbolt the shipping hold-down brackets from the skid, then remove the brackets from the appliance.
4. If the equipment is to be installed on 6” legs, go to Step 2a.
If the equipment is to be installed on 6” casters, go to Step 2b.

STEP 2A: ATTACH LEGS

A set of four legs is packed with equipment ordered with legs. (For units ordered with casters, go to Step 2b.)

1. Raise equipment sufficiently to allow legs to be attached. For safety, "shore up" and support the equipment with an adequate blocking arrangement strong enough to support the load.
2. Screw the legs into the leg pad holes, located on bottom at each corner. The legs should be fully screwed into the leg pads.
3. Lower unit gently onto a level surface. Never drop or allow the unit to fall.
4. Go on to Installation Step 3.

Figure 5

Installation of Legs

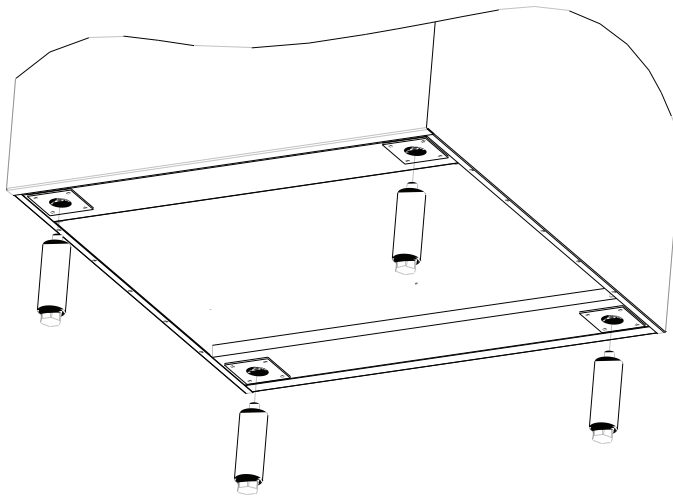

STEP 2B: ATTACH CASTERS

NOTICE

For an appliance equipped with casters, (1) the installation shall be made with a connector that complies with the *Standard for Connectors for Movable Gas Appliances, ANSI Z21.69* or *Connectors for Moveable Gas Appliances, CAN/CGA-6.16*, and a quick-disconnect device that complies with the *Standard for Quick-Disconnect Devices for Use With Gas Fuel, ANSI Z21.41*, or *Quick Disconnect Devices for Use with Gas Fuel, CAN1-6.9*, (2) adequate means must be provided to limit the movement of the appliance without depending on the connector and the quick-disconnect device or its associated piping to limit the appliance movement, and (3) the restraining means should be attached to a frame member on the back of the unit.

A set of four casters is packed with equipment ordered with casters (instead of legs).

A threaded leg pad is fastened to the base frame at each corner. Each caster has a corresponding mating thread. The casters can be adjusted to overcome a slightly uneven floor. Casters are provided with a fitting for proper lubrication when required.

1. Raise unit sufficiently to allow the casters to be attached. For safety, "shore up" and support the unit with an adequate blocking arrangement strong enough to support the load.
2. Screw the casters into the holes in the centers of the leg pads. Install the casters that have a locking brake under the front of the unit.
3. Lower the unit gently onto a level surface. Never drop or allow the unit to fall.
4. Go to Installation Step 3.

Figure 6

Installation of Casters

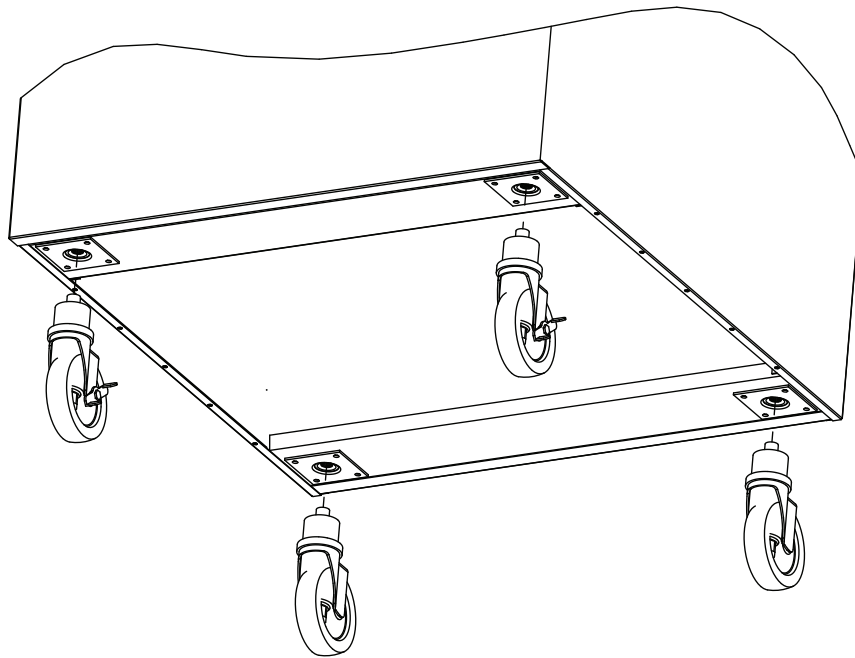

STEP 3: ATTACH RESTRAINT

NOTICE

For an appliance equipped with casters, (1) the installation shall be made with a connector that complies with the *Standard for Connectors for Movable Gas Appliances, ANSI Z21.69* or *Connectors for Moveable Gas Appliances, CAN/CGA-6.16*, and a quick-disconnect device that complies with the *Standard for Quick-Disconnect Devices for Use With Gas Fuel, ANSI Z21.41*, or *Quick Disconnect Devices for Use with Gas Fuel, CAN1-6.9*, (2) adequate means must be provided to limit the movement of the appliance without depending on the connector and the quick-disconnect device or its associated piping to limit the appliance movement, and (3) the restraining means should be attached to a frame member on the back of the unit.

Install the restraint cable to an appliance mounted on casters using the following procedure:

1. Secure the restraining device bracket (item "B" in the following illustration) to a wall stud located as close as possible to the appliance connector inlet and outlet connections. Use four #12 screws (item "C") and plastic anchors (item "A") if necessary.
2. Install eye-bolt (item "F") to a frame member on the rear of the equipment. After checking carefully behind the frame member for adequate clearance, drill a 1/4" hole through the frame member.
3. Thread hex nut (item "G") and slide the washer (item "H") onto the eye-bolt. Insert the eye-bolt through the 1/4" drilled hole and secure with a washer (item "H") and nylon lock nut (item "I").
4. Using the spring-loaded snap hooks, attach the restraining device to the bracket and the eye-bolt.
5. Using the cable clamp (item "D"), adjust the restraining device extended length to prevent over-bending or kinking of the appliance connector.

Figure 7

Installation of Restraint

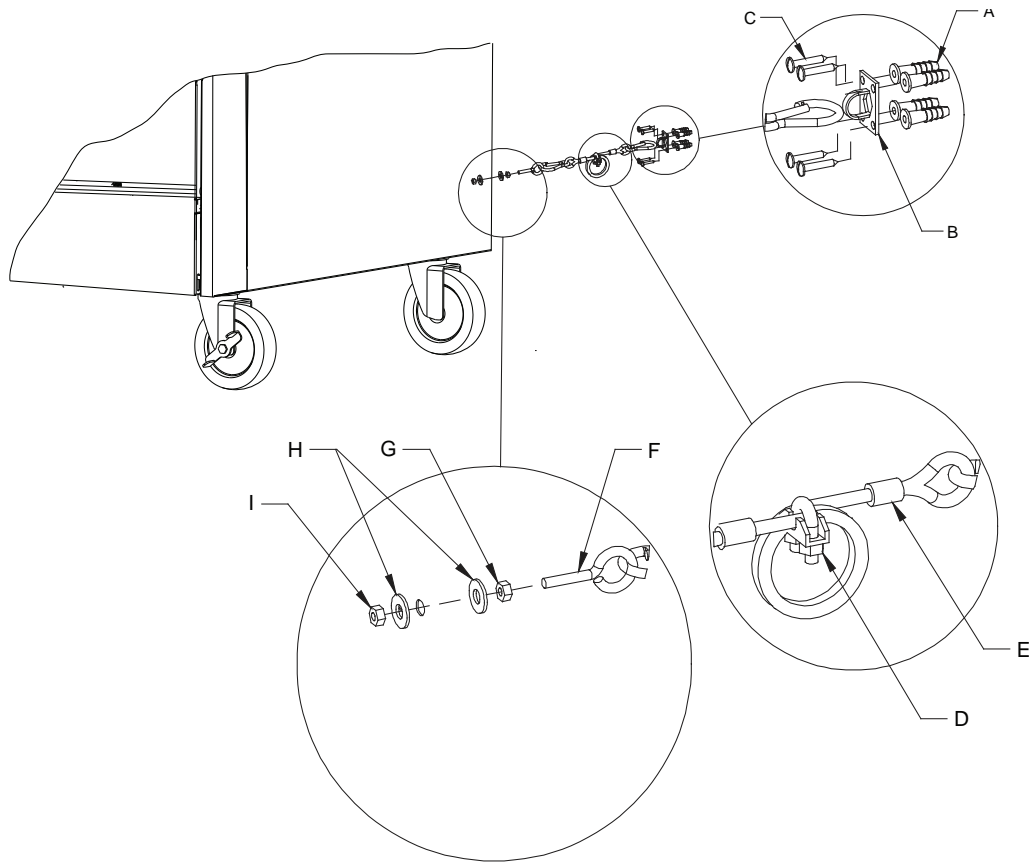

Be sure all controls are turned off prior to disconnecting. After reconnecting, be sure all controls are turned off and all pilots are lit.

NOTICE

Adequate means must be provided to limit the movement of the appliance without depending on the connector and the quick-disconnect device or its associated piping to limit the appliance movement.

The restraining means should be attached to a frame member on the back of the unit.

STEP 3: INSTALL BROILER CERAMICS

The broiler ceramic tiles must be installed before operating the broiler. Do the following for each of the two broiler compartments:

1. Locate and unwrap 20 of the 40 ceramic tiles shipped with the broiler.
2. Lift the front of the burner baffle up, then pull the baffle forward and out of the broiler.
3. Position the ceramic tiles on both sides of both burners. The tile edges will rest on burner lips and side supports. Be certain tiles are installed with cone-shaped projections pointing downward.
4. Replace the burner baffle.

STEP 4: CONNECT BATTERY SECTIONS (OVEN BASE ONLY)

If the unit is part of a battery, and the battery was shipped partially disassembled, connect the battery sections using the following procedure.

1. Remove valve panels from all sections. Mark them so that they can be returned to their respective section.
2. Position the center section of the battery and carefully level that unit. Use a long spirit level four ways; across front top rail and the rear edge, and along each side edge.
3. If not already in place, attach pipe-union to front manifold of the battery. Screw it in far enough to be able to slide the adjacent section into position.
4. Bring up adjacent section and level it using the same method and by using the center unit as reference. Match front rails and rear edge. When a battery is set on a masonry base and legs are not used, shims may be used. Special attention should be given to griddle tops to allow proper drainage.
5. Bolt the frames of the sections together.
6. Connect the front manifolds using the pipe-union.
7. Attach the trim-strip between the section tops.
8. Install the continuous front-rail, if ordered.
9. Slide control knobs onto their shafts (to operate the sections during the installation procedure), but do not yet reattach valve panels or front-panel trim pieces.

STEP 5: CONNECT ELECTRICITY (OVEN BASE)

A wiring diagram is located behind the kick panel of the oven-base. Be sure that the input voltage and phase match the requirements shown on the serial plate.

Oven-bases ordered with a 115V, 60Hz, single-phase electrical rating are factory-supplied with a three-wire cord with a three-prong plug that fits any standard three-prong grounded receptacle. Each standard oven requires a 15 ampere supply, while each convection oven requires a 20 ampere supply.

Oven-bases ordered with a 208/236V, 60Hz, single- or three-phase electrical rating are factory-equipped with a two-pole terminal block located behind cover plate located on the rear of the unit. To connect the supply wires, remove the cover plate. Route the supply wires and the grounding wire through the strain relief fitting to the terminal block. Insert the supply wires, one each, into the two poles of the terminal block and tighten the screws. Insert the ground wire into the grounding lug and tighten the screw. Re-attach the cover plate.

Three phase units are wired as above, using only two supply wires. The third wire is not used and must be properly terminated.

All units are shipped wired as specified by factory order. Conversion between single-phase and three-phase can be accomplished by referring to phase loading and line amperes chart on the wiring diagram for wire size and ampere requirements.

STEP 7: CONNECT GAS SUPPLY

If the Southbend equipment is being installed at over 2,000 feet altitude and that information was not specified when ordered, contact the appropriate authorized Southbend Service Representative or the Southbend Service Department. Failure to install with proper orifice sizing will result in poor performance and may void the warranty.

Southbend equipment is design-certified for operation on natural or propane gases. The units are shipped configured and adjusted for the type of gas specified by the purchaser, which is indicated on the serial plate (see Figure 1 and Figure 2). Connect the equipment ONLY to the type of gas for which it is configured and adjusted.

Minimum supply pressure is 7" W.C. for natural gas, 11" W.C. for propane. An external pressure regulator and shut off valve are provided. If using a flexible-hose gas connection, the I.D. of the hose must not be smaller than the connector on the equipment, and must comply with ANSI Z21.69. Provide an adequate means of restraint to prevent undue strain on the gas connection.

If applicable, the vent line from the gas pressure regulator shall be installed to the outdoors in accordance with local codes, or in the absence of local codes, with the National Fuel Gas Code, ANSI Z223.1, Natural Gas Installation Code, CAN/CGA-B149.1, or the Propane Installation Code CAN/CGA-B149.2, as applicable.

An adequate gas supply is imperative. Undersized or low pressure lines will restrict the volume of gas required for satisfactory performance. Fluctuations of more than 25% on natural gas or 10% on propane gas will create problems and affect burner operating characteristics. A 1/8" pressure tap is located on the manifold to measure the manifold pressure. The supply line to the unit should be no smaller than the inside diameter of the pipe on the equipment to which it is connected.

 **CAUTION**

ALL PIPE JOINTS AND CONNECTIONS MUST BE TESTED THOROUGHLY FOR GAS LEAKS. USE ONLY SOAPY WATER FOR TESTING ON ALL GASES. NEVER USE AN OPEN FLAME TO CHECK FOR GAS LEAKS. ALL CONNECTIONS MUST BE CHECKED FOR LEAKS AFTER THE EQUIPMENT HAS BEEN PUT INTO OPERATION. TEST PRESSURE SHOULD NOT EXCEED 1/2 psi (3.45 kpa) or 35 mbar (14" W.C.).

STEP 8: CHECK THE INSTALLATION

1. Check that all screws and bolts are tightened.
2. Check electrical connection(s).
3. Check gas connection(s).
4. Move the appliance into the final position at which it will be operated.
5. Check that the appliance is level. If not, adjust the legs or casters.
6. Check that the appropriate minimum clearances are satisfied (see page 5).
7. Check that there is sufficient clearance to fully open all doors and pull-out all broiler grid(s) and drippings drawer(s).
8. Check that adequate ventilation (fresh air supply and hood exhaust) is available.
9. Wipe clean all cooking surfaces.
10. Check that nothing is obstructing the air intake openings and/or the combustion-exhaust openings.

STEP 9: CHECK BROILER OPERATION

1. Turn gas supply on. Immediately check all gas connections for leaks using soapy water.
2. Light all pilots (see Operation section). Check all pilots for correct flame height.
3. Turn on each of the four broiler burners one at a time and check for correct flame appearance and height at both the LOW and HIGH settings.
4. Turn all four broiler burners to the HIGH setting at the same time and check for correct flame appearance and height.
5. Turn-off all burners and allow the broiler to cool.

STEP 10: SHUT-DOWN AND WIPE-CLEAN

1. Wipe clean all surfaces.
2. Unless the broiler is to be placed in service immediately, shut off the gas and electricity supplies.
3. Make sure that a copy of this manual will be available to the people who will operate and maintain the broiler.

OPERATION

 **DANGER**
EXPLOSION HAZARD

In the event a gas odor is detected, shut down equipment at the main gas shut-off valve and immediately call the emergency phone number of your gas supplier.

Improper ventilation can result in headaches, drowsiness, nausea, and could result in death. Do not obstruct the flow of combustion and ventilation air to and from cooking appliances.

 **CAUTION**

To eliminate gas build up which could result in an explosion, in the event of a burner ignition failure a five minute purge period must be observed prior to re-establishing ignition source.

NOTICE

This appliance is not intended for use by persons (including children) with reduced physical, sensory or mental capabilities, or lack of experience and knowledge, unless they have been given supervision or instruction concerning use of the appliance by a person responsible for their safety. Children should be supervised to ensure that they do not play with the appliance.

NOTICE

Southbend Infrared broilers cook food in about half the time of conventional broilers, so adjust cooking times accordingly.

LIGHTING AFTER GAS HAS BEEN SHUT OFF

When turning on the main gas supply after it has been shut off, do the following:

1. Make sure that all four burner control knobs are in the OFF position.
2. Turn on the main gas supply valve(s).
3. Light the four pilots located near the front of the burners. The pilot flames should be steady and about 1/2" high.

OPERATION OF BROILER

Each broiler grid is 24-1/2" wide by 28" deep, and rolls out 17-1/4". The front 3" of the grid receives less heat, and so can be used as a holding area. As food cooks, drippings drain into a collection drawer that is out of the heat zone. To operate the broiler, do the following:

1. Light the constant-burning pilots located near the front of the broiler burners (unless the pilots are already lit)
2. Turn the burner controls to HIGH and visually check that the burners have ignited. When the burners ignite, a blue flame will carry across the ceramic tiles. Flames may lift from the burner until temperatures stabilize. When the burner control is set to HIGH, the ceramic tips will glow red across the entire tile. When the burner control is set to LOW, the ceramic tips will glow red across 2/3 of each tile. (If the flame continues to lift after 10 minutes, or if the flame remains yellow and sooting occurs, the broiler requires adjustment by a service technician.)
3. Raise or lower the broiler rack to the height appropriate for the food to be cooked.
4. Pull out the broiler rack and place on the grate the food to be cooked. The front 3" of the grate receives less heat and so can be used as a holding area.

5. When done broiling, turn the burner control knobs OFF (the constant-burning pilots will remain lit).
6. When done broiling, turn the burner controls to OFF. (To keep the broiler rack hot in order to mark food with sear marks without preheating, turn the burner controls to LOW and move the broiler rack to its highest position.)

LIGHTING BROILER PILOTS

The pilots should burn continuously unless the broiler is to be completely shut down. Each broiler cavity has two pilots, each near the front of a pair of burners. If the pilots are extinguished, the pilot gas supply is automatically interrupted. To light the pilots, do the following:

1. Turn all broiler burner valves to the OFF position.
2. Verify the main gas supply valve is turned "ON".
3. Visually locate the pilots and light with long stem lighter or kitchen match.
4. Turn all broiler knobs to the "HIGH" position.

SHUTDOWN OF BROILER

To place the broiler in a standby state (ready for use), turn all burner control valves & blower switch to OFF.

(The pilots will remain lit.)

To completely shut down the equipment for an extended period (or prior to disconnecting the gas supply), do the following:

1. Turn all burner control knobs & blower switch to OFF.
2. Turn OFF the manual shut-off valves of all gas supply connections. (This will extinguish all pilots.)

Figure 8

Controls

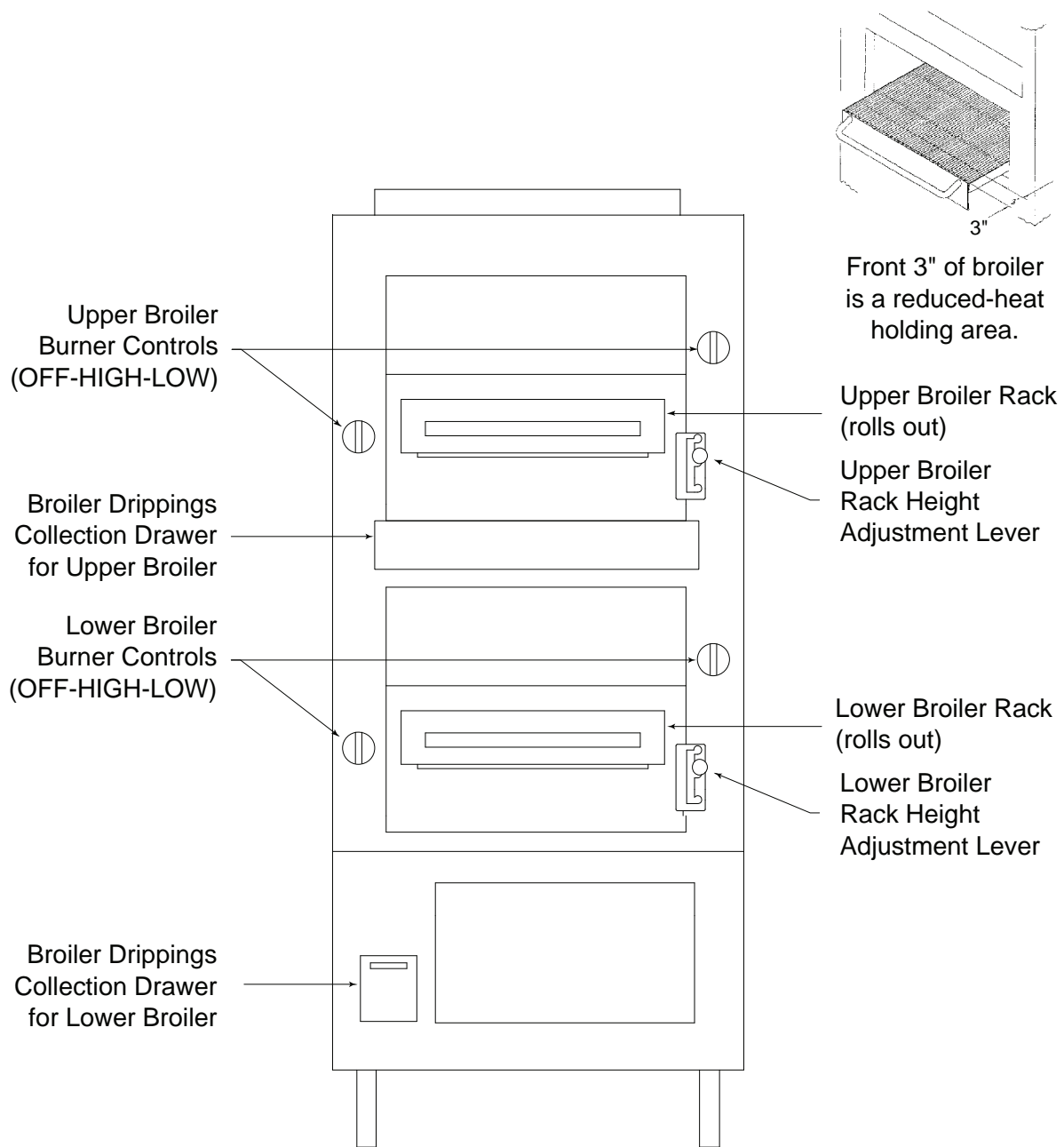

Figure 9

Operation of Oven

Each oven has a thermostatic control that can be set in the oven 175°F to 550°F (66°C to 260°C). Convection ovens have a fan that can be set to HI speed or LO speed.

For advice on using a convection oven, see the information on the following two pages of this manual.

While cooking, if the door is opened on a convection oven, the fan will temporarily stop until the door is closed.

Do not allow excessive drippings and/or debris to accumulate on the interior of the oven. When necessary, pull out and clean the oven-bottom tray.

To light and start cooking, do the following:

FOR UNITS WITH A STANDING PILOT

1. Open kick panel and locate knob on valve assembly.
2. Turn the knob to PILOT and press inward. While holding the knob inward, light the pilot with an appropriate lighter.
3. Hold knob in the inward position for 30 seconds and release. The pilot should remain lit.
4. Turn the knob to ON and close kick panel.
5. Select on the thermostat the cooking temperature appropriate for the food to be cooked.
6. For convection ovens, select the fan speed appropriate for the food to be cooked.

FOR UNITS WITH ELECTRONIC IGNITION

1. Set the Oven Power Switch to ON. The pilot will light automatically (You will hear a “snapping” sound until the pilot ignites.)
2. Select on the thermostat the cooking temperature appropriate for the food to be cooked.
3. For convection ovens, select the fan speed appropriate for the food to be cooked.
4. On units with a cooking light, the light will go out when the oven reaches the set temperature.

When done cooking, turn the Oven Power Switch to OFF.

Controls for Ovens with Standing Pilot

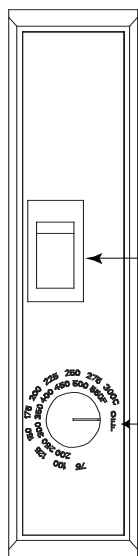

Controls for Ovens with Electronic Ignition

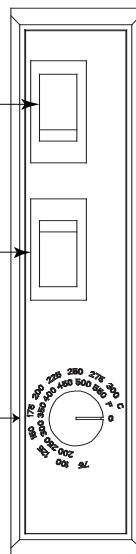

Oven Power Switch

Fan-Speed Switch
(for Convection Ovens)

Oven Thermostat

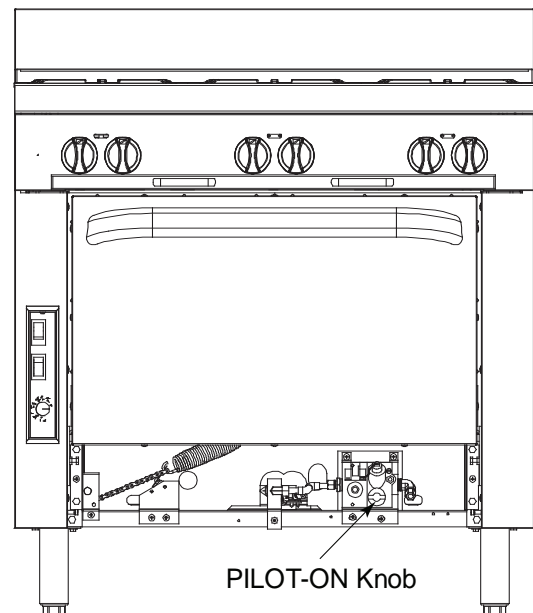

PILOT-ON Knob

WARNING

THE USE OF ALUMINUM FOIL CAN CAUSE HEAT DISTRIBUTION PROBLEMS IN OVENS. EXTREME CARE MUST BE USED WHEN PLACING ALUMINUM FOIL IN THE OVEN TO ENSURE THAT IT DOES NOT BLOCK OR CHANGE THE AIR FLOW. THE USE OF ALUMINUM FOIL MAY VOID THE PRODUCT WARRANTY IF ITS USE IS ASCERTAINED TO BE A PROBLEM.

SUGGESTIONS FOR COOKING USING A CONVECTION OVEN

As a guide, set oven temperatures 25 to 50 degrees lower than called for in recipes using conventional (non-convection) ovens.

FROZEN ENTREE PRODUCTS: Punch holes in lid before heating. Tent lid if product has a tendency to stick, i.e., lasagna or macaroni and cheese. Use manufacturer's convection oven directions for time and temperature or reduce conventional oven temperature 50 degrees for a 6-1/2 size pan load. Some products may cook in 10 to 15 minutes less time than recommended for convection ovens if prepared from frozen in a 6 pan load.

Time and temperatures will vary depending upon load, mix, size of portion, and other factors. Use the following chart to develop your own cooking techniques:

Product	Timing (minutes)	Temperature Setting	Number of Racks Used	Count per Pan/Rack
Hamburger buns, 3 oz. - 4"	18	375°	3	24
Yeast rolls - 1 oz. Use temperature and time recommended by manufacturer for convection ovens for a 3 pan load.	10	400°	3	48
Fruit pies, 46 oz. frozen Use temperature and time from manufacturer's directions for convection ovens for a 12 pie load placed on 3 bun pans.	50	375°	3	4
Egg custard pies, 44 oz. frozen	60	325°	3	4
Dutch apple pies, 46 oz. frozen	50	350°	3	4
Baked potatoes, 8 oz. Wash and wrap in potato foil. Place 30 potatoes on 18 x 24 bun pan — 3 pans per load. Bake in 400°F oven for 1 hour.	60	400°	3	30 (wrapped)
Pre-blanch potatoes, frozen Spread on ungreased bun pans, 3 pans per load. Bake at 400°F, stirring once, for 15 to 18 minutes	16	400°	3	5lb.
Fish portions, pre-cooked, breaded, 3 oz. Use manufacturer's recommended temperature and time for convection oven for a 3 pan load.	16	400°	3	32
Macaroni & cheese, 6 lbs. - 40° temp.	45	400°	3	2-6lbs.
Lasagna w/meat sauce, 6 lb. - 40° temp.	60	350°	3	2-6lbs.
Lasagna w/meat sauce, 6 lb. - frozen	75	350°	3	2-6lbs.
Salisbury steak w/gravy, 6 lb. - 40° temp.	45	400°	3	2-6lbs.
Top round of beef No. 168				
14 lb. - rare	140° internal 14 min./lbs.	250°	1	1-2
14 lb. - medium	150° internal 14 min./lbs.	250°	1	1-2
14 lb. - well done	160° internal 14 min./lbs.	250°	1	1-2

CORRECTING PROBLEMS WHEN COOKING WITH A CONVENTION OVEN

If...	Then...
Cakes are dark on the sides and not done in the center...	lower oven temperature
Cake edges are too brown...	reduce number of pans or lower oven temperature
Cakes have light outer color...	raise temperature
Cake settles slightly in the center...	bake longer or raise oven temperature slightly. Do not open doors too often for long periods.
Pies have uneven color...	reduce number of pies per rack.
Meats are browned, but not done in center...	lower oven temperature and roast longer
Meats are well done and not browned...	raise temperature. Limit amount of moisture
Cakes ripple...	pans are overloaded or batter is too thin
There is excessive meat shrinkage...	lower oven temperature.
Cakes are too coarse...	lower oven temperature

TROUBLESHOOTING BY OPERATOR

The following table lists the possible causes and solutions of problems that may occur during operation.

Problem	Possible Causes and Solutions
A top burner will not light.	<ul style="list-style-type: none"> - Check pilot position. - Check and light the burner's pilot. - Check gas supply to unit.
Oven will not heat up.	<ul style="list-style-type: none"> - Check and light the oven pilot. - Check gas supply to unit.
Blower of convection oven is not running.	<ul style="list-style-type: none"> - Check that the oven's blower control switch is in ON position. - Check electricity supply to unit.
Pilot(s) will not remain lit.	<ul style="list-style-type: none"> - Check gas supply to unit. - Check pilot adjustment.

If other appliances connected to the same source of gas or electricity are also not operating correctly, the problem is likely not within the equipment.

If the problem only occurs for the Southbend equipment, and if the above solutions do not solve the problem, call for repair service.

WARNING

THE USE OF ALUMINUM FOIL CAN CAUSE HEAT DISTRIBUTION PROBLEMS IN OVENS. EXTREME CARE MUST BE USED WHEN PLACING ALUMINUM FOIL IN THE OVEN TO ENSURE THAT IT DOES NOT BLOCK OR CHANGE THE AIR FLOW. THE USE OF ALUMINUM FOIL MAY VOID THE PRODUCT WARRANTY IF ITS USE IS ASCERTAINED TO BE A PROBLEM.

CLEANING

WARNING

Disconnect the power supply to the appliance before cleaning. Do not remove panels that require tools to remove.

WARNING

Adjustments and service work should be performed only by a qualified technician who is experienced in, and knowledgeable with the operation of commercial gas cooking equipment. To assure confidence, contact your authorized service agency for reliable service, advice and other assistance with your appliance. Insist upon genuine factory parts to be used for any repair or service of your appliance.

Southbend appliances are sturdily constructed of the best materials and are designed to provide durable service when treated with ordinary care. To expect the best performance, your equipment must be maintained in good condition and cleaned daily. Naturally, the periods for this care and cleaning depend on the amount and degree of usage.

Following daily and periodic maintenance procedures will enhance long life for your equipment. Climatic conditions (such as salt air) may require more thorough and frequent cleaning or the life of the equipment could be adversely affected.

Keep exposed, cleanable areas clean at all times.

DAILY CLEANING AND MAINTENANCE

The daily cleaning procedure is as follows:

1. Remove, empty, and clean drippings collection drawer(s)
2. Clean drippings drain chute.
3. Thoroughly wash grease hopper below rack(s)
4. Thoroughly wash rack(s)
5. Remove and clean all oven racks and oven-bottom trays. Wipe clean the interior of the oven.
6. Wipe clean all exterior surfaces.
7. Replace the cleaned and dried drippings trays, grease drawers, and oven components.

The following tasks should be performed monthly:

1. Clean around burners, pilots, and orifices if debris has accumulated.
2. Visually assure proper pilot operation.
3. Inspect and lubricate valves and bearings as needed

VENT SYSTEM:

At least twice a year the unit venting should be examined and cleaned.

STAINLESS-STEEL SURFACES

To remove normal dirt, grease and product residue from stainless steel surfaces that operate at LOW temperature, use ordinary soap and water (with or without detergent) applied with a sponge or cloth. Dry with a clean cloth.

To remove BAKED-ON grease and food splatter, or condensed vapors; apply cleanser to a damp cloth or sponge and rub cleanser on the metal in the direction of the polishing lines on the metal.

Rubbing cleanser, as gently as possible, in the direction of the polished lines will not mar the finish of the stainless steel. NEVER RUB WITH A CIRCULAR MOTION. Soil and burnt deposits which do not respond to the above procedure can usually be removed by rubbing the surface with SCOTCH-BRITE scouring pads or STAINLESS scouring pads. DO NOT USE ORDINARY STEEL WOOL as any particles left on the surface will rust and further spoil the appearance of the finish. NEVER USE A WIRE BRUSH, STEEL SCOURING PADS (EXCEPT STAINLESS), SCRAPER, FILE OR OTHER STEEL TOOLS. Surfaces which are marred collect dirt more rapidly and become more difficult to clean. Marring also increases the possibility of corrosive attack. Refinishing may then be required.

“Heat tint” is darkened areas that sometimes appear on stainless steel surfaces where the area has been subjected to excessive heat. These darkened areas are caused by thickening of the protective surface of the stainless steel and are not harmful. Heat tint can normally be removed by the foregoing, but tint which does not respond to this procedure calls for a vigorous scouring in the direction of the polish lines using SCOTCH-BRITE scouring pads or a STAINLESS scouring pad in combination with a powered cleanser. Heat tint may be lessened by reducing heat to equipment during slack periods.

BROILER

To prevent excess smoking, the grids, rack drip pan, and the other broiler components must be kept clean of food remnants. Use a wire brush or similar scraping utensil. DO NOT use steel wool or similar scrub pad that will leave small particles, which can get into food. The cleaning procedure is as follows:

1. Move the broiling rack to the low position. Pull out the rolling broiler rack.
2. Lift out the broiler grid and clean it with a wire brush or non-toxic solvent.
3. Remove the rack pan and clean.
4. With rolling rack pulled-out to its “stop,” raise front handle so rack’s rollers will come through the notches in the raising and lowering frame. Clean all parts where residue can collect.
5. Clean all parts of the raising and lowering frame.
6. Clean entire hopper section of all caked grease and residue.
7. Lubricate bearings with cooking oil.
8. Reverse procedure to reassemble broiling rack mechanism.

OVEN INTERIOR

WARNING

FOR YOUR SAFETY, DISCONNECT THE POWER SUPPLY TO THE SOUTHBEND EQUIPMENT BEFORE CLEANING THE OVEN. WHEN CLEANING THE BLOWER WHEEL OF A CONVECTION OVEN, BE SURE TO HAVE THE POWER SWITCH IN THE “OFF” POSITION.

To clean the oven interior, first allow the oven to cool. Remove oven bottom and clean it by rubbing with strong detergent and a Brillo pad or similar scrubber. “Spillovers” should be cleaned from the bottom as soon as possible to prevent carbonizing and a “burnt-on” condition. For stubborn accumulations, commercial oven cleaners are recommended.

The porcelain oven door lining can be cleaned in a similar manner. The side, rear and top lining should be wiped only with a cloth dampened with a mild detergent and water. Avoid using excessive amounts of water, as this may drip into burner compartment and deteriorate the metal in that area. Do not use strong commercial cleaners or abrasive pads on the side, rear or top linings, as they may damage the finish or leave gray residue

BLACK BAKED-ENAMEL SURFACES

Allow appliance to cool somewhat after use and wash black baked-enamel surfaces with a hot, mild detergent or soap solution. In particular, clean off all grease deposits. Dry thoroughly with a dry cloth.

ADJUSTMENTS

WARNING

ADJUSTMENTS AND SERVICE WORK MAY BE PERFORMED ONLY BY A QUALIFIED TECHNICIAN WHO IS EXPERIENCED IN, AND KNOWLEDGEABLE WITH, THE OPERATION OF COMMERCIAL COOKING EQUIPMENT. HOWEVER, TO ASSURE YOUR CONFIDENCE, CONTACT YOUR AUTHORIZED SERVICE AGENCY FOR RELIABLE SERVICE, DEPENDABLE ADVICE OR OTHER ASSISTANCE, AND FOR GENUINE FACTORY PARTS.

NOTICE

Warranty will be void and the manufacturer is relieved of all liability if service work is performed by other than a qualified technician, or if other than genuine Southbend replacement parts are installed.

ACCESS TO SERVICEABLE COMPONENTS

To open the kick panel below the oven door, lift the kick panel straight up and pull the top edge away from the oven. The kick panel is hinged at the bottom corners.

To remove the valve panel, first remove the knobs. Then remove the two screws on the bottom of the valve panel (except on modular-countertop base models). Pull the bottom of the valve panel away from the range. The top edge of the valve panel has two small slots that hook over tabs on the frame.

To access the rear of the oven control panel, first remove the valve panel. Then remove the screw that holds the top of the oven control panel in place. Tilt the top of the oven control panel outward, being careful not to damage the wires or the thermostat sensor.

To service the blower motor from the front of the oven, first remove the blower baffle from the rear of the oven cavity (lift it up and out). Then disconnect the motor-mount plate by removing the eight hex nuts that secure it to the oven interior back. Pull the mount-plate, with motor attached, into the oven cavity.

ADJUSTMENT OF BROILER PILOTS

The pilots are adjusted at the factory. If the flame is leaving its port, or “blowing off,” the result is an unstable condition in which the pilot may extinguish. Re-adjustment is necessary, adjust each burner’s pilot using the following procedure:

1. If necessary, light the pilots.
2. Locate the pilot adjustment fitting that connects the pilot gas supply tubes to the gas manifold. For each of the two pilots, turn the pilot adjustment screw to the left to increase the size of the pilot flame, or to the right to decrease the size of the pilot flame. The flame should be about 1/2” high with a slight yellow tip. The maximum pilot flame height is 3/4”. The flame is too high if the yellow tip is producing black streaks of carbon.

Figure 10

ADJUSTMENT OF OVEN THERMOSTAT

The oven thermostat is carefully calibrated at the factory so that the dial setting matches the actual oven temperature. Field recalibration is seldom necessary, and should not be resorted to unless considerable cooking experience definitely proves that the control is not maintaining the temperatures to which the dial is set.

Obtain a test instrument or a reliable mercury thermometer, then do the following:

1. Place the thermocouple of test instrument or the thermometer in the middle of the oven.
2. Turn on the oven and set the thermostat to 400°F.
3. After the oven has been on about 20 minutes check oven temperature. The oven door should be open for as short a time as possible. Use a flashlight, if necessary, to see the thermometer clearly.
4. Continue to check the temperature at 5-minute intervals until two successive readings are within 5 degrees of each other.

The thermostat should be recalibrated if the reading is not within 20 degrees of the dial setting (400°F). If calibration is required, adjust the thermostat, as follows:

5. Remove the oven temperature control knob. Be careful to not turn the stem (which would change the temperature setting).
6. While holding the stem in place, turn the calibration screw (see drawing below). If the actual measured temperature is lower than the dial setting, turn the screw counterclockwise. If the measured temperature is higher than the dial setting, turn the screw clockwise. Replace the control knob.
7. Set the oven temperature to 450°F. After about 20 minutes, check the oven temperature. Continue to check the temperature at 5-minute intervals until two successive readings are within 5 degrees of each other. If the actual oven temperature is not within 20 degrees of the dial setting (450°F), replace the thermostat.

Remove oven thermostat control knob.

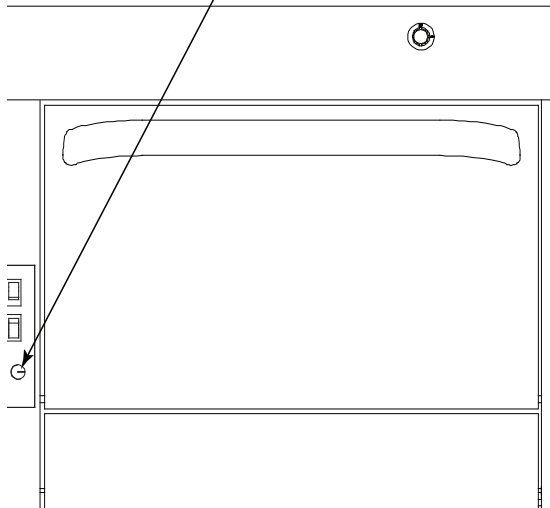

With the control knob removed, the control shaft will extend out of the control panel.

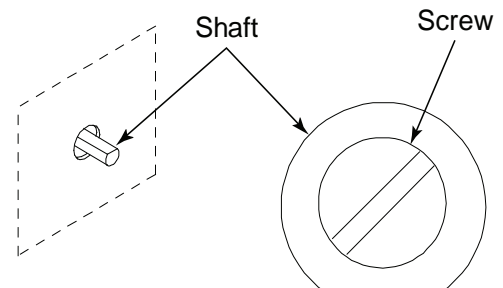

Calibrate the thermostat by holding the shaft in place while turning the screw counterclockwise to increase the temperature, or clockwise to decrease the temperature.

Figure 11

ADJUSTMENT OF OVEN PILOT AND BURNER

The burner orifice is of the fixed type, sized for the type of gas and the operating altitude. To adjust the burner air-gas mixture, loosen the screw that secures the air shutter on the mixer face and rotate the mixer cap to obtain a clear, stable blue flame with a distinct inner cone at each port. Excessive primary air causes "blowing" (the flames leaving the ports), while insufficient primary air causes a soft or yellow tipped flame.

The oven pilot flame is adjusted by using a screwdriver to turn the adjusting screw on the pilot line valve (see drawing below). The pilot line valve is located behind the kick panel below the oven door. To gain access, lift the kick panel straight up and pull the top edge out.

UNITS WITH ELECTRONIC IGNITION

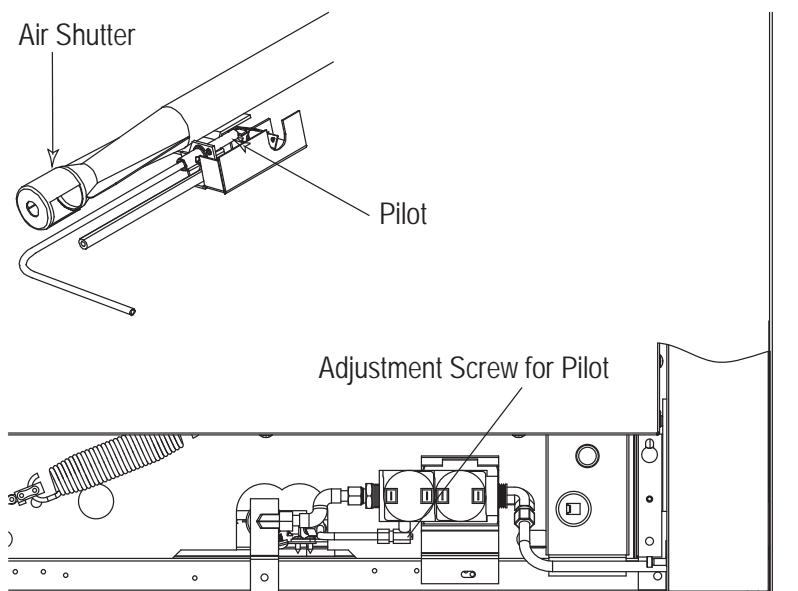

UNITS WITH STANDING PILOT

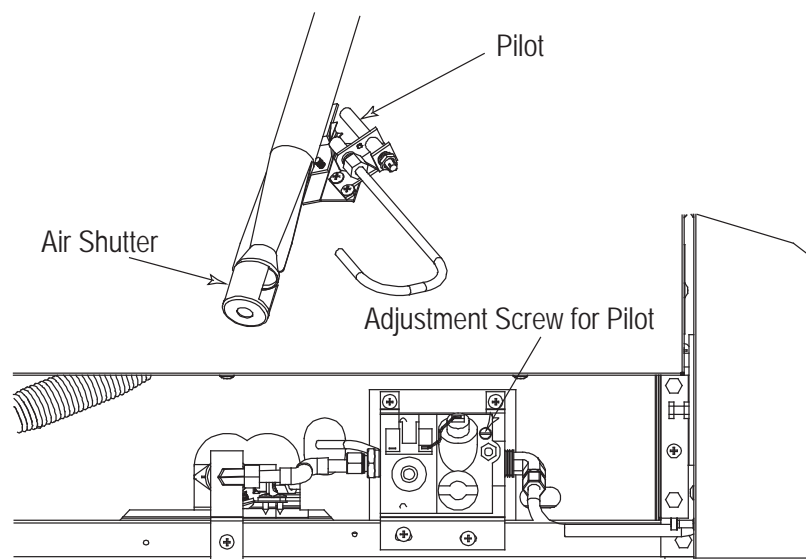

ADJUSTMENT OF MANIFOLD GAS PRESSURE (OVEN BASE)

There is not an internal pressure regulator. The external pressure regulators supplied by Southbend are factory set at 6" W.C. for natural gas and 10" W.C. for propane gas. To check the manifold pressure, do the following:

1. Turn OFF all thermostats, burner controls, gas shut-off valves, and the external gas supply connection(s).
2. Remove the valve panel and locate the 1/8" plug in the front manifold furthest from the gas connection location. Remove the plug and install a fitting appropriate to connect a manometer.
3. Turn ON all gas supply valves and light all pilots.
4. Turn all burners and ovens to full ON position and read manometer.
5. If manometer does not read 6" W.C. for natural gas (or 10" W.C. for propane gas) adjust regulator by removing the cap from the top of regulator. Use a screwdriver to rotate the regulator adjustment screw clockwise to increase pressure, or counterclockwise to decrease pressure, until manometer shows correct reading.
6. Turn OFF all thermostats, burner controls, gas shut-off valves, and the external gas supply connection(s).
7. Remove manometer fitting and replace plug in manifold.
8. Turn ON all gas valves and light all pilots.
9. Replace valve panel.

ADJUSTMENT OF MANIFOLD GAS PRESSURE (BROILER)

ADJUSTMENT OF PRESSURE REGULATOR

The pressure regulator is factory set at 4" W.C. for natural gas and 10" W.C. for propane gas. To check and/or adjust the pressure, do the following:

1. Locate the pressure regulator and 1/8" pressure tap, which are located in the service compartment at the bottom of the broiler (which is accessed through a removable panel on the front of the broiler, see Figure 4). The tap is located just after the pressure regulator. A manual gas shut-off valve is located just before the pressure regulator.
2. Turn all burner control valves to the OFF position, then turn the manual gas shut-off valve to the OFF position.
3. Remove the 1/8" plug from the pressure tap and connect the manometer.
4. Turn the manual gas shut-off valve to the ON position.
5. Light the pilots.
6. Turn all burner control knobs to the HIGH position. Verify that the burners ignite.
7. Check whether the manometer reads 4" W.C. for natural gas (or 10" W.C. for propane gas). If it does, skip to Step 11, otherwise continue with the next step.
8. Remove the cap from the top of the pressure regulator.
9. Using a screwdriver, turn the regulator adjustment screw clockwise to increase, or counterclockwise to decrease, the pressure until the manometer shows the correct pressure.
10. Put the cap back on top of the pressure regulator.
11. Turn all burner control valves to the OFF position, then turn the manual gas shut-off valve to the OFF position.
12. Disconnect the manometer and replace the 1/8" plug into the pressure tap.
13. Replace the removable filter on the front of the broiler.
14. Turn the manual gas shut-off valve to the ON position.
15. Light the pilots.
16. Turn on the broiler burners and check for normal flame appearance.

TROUBLESHOOTING

WARNING

ADJUSTMENTS AND SERVICE WORK MAY BE PERFORMED ONLY BY A QUALIFIED TECHNICIAN WHO IS EXPERIENCED IN, AND KNOWLEDGEABLE WITH, THE OPERATION OF COMMERCIAL COOKING EQUIPMENT. HOWEVER, TO ASSURE YOUR CONFIDENCE, CONTACT YOUR AUTHORIZED SERVICE AGENCY FOR RELIABLE SERVICE, DEPENDABLE ADVICE OR OTHER ASSISTANCE, AND FOR GENUINE FACTORY PARTS.

NOTICE

Warranty will be void and the manufacturer is relieved of all liability if service work is performed by other than a qualified technician, or if other than genuine Southbend replacement parts are installed.

Replacement parts (including parts not listed in this manual) may be ordered either through a Southbend Authorized Parts Distributor or a Southbend Authorized Service Agency.

When ordering parts, please supply the Model Number, Serial Number, Part Number, and Part Description.

In case of problems in operation at initial installation, check type of gas and manifold pressure and compare with information listed on the serial plate.

TROUBLESHOOTING FLOWCHARTS, PROCEDURES, AND WIRING DIAGRAMS

Find the symptom below that corresponds to the malfunction, then turn to the corresponding page. Follow the flowchart on that page until the problem is solved.

NOTICE

This section contains troubleshooting flowcharts, procedures, and electric schematics to assist a qualified service technician in the servicing of Southbend cooking equipment. Information in the troubleshooting section is intended only as a guideline to isolate and test components. Before performing repair or ordering parts contact a Southbend Technical Service representative at 919-762-1000 option 2.

Troubleshooting Flowchart, Procedure, or Wiring Diagram	Page
Troubleshooting Oven Pilot	35
120 Volt Electronic Ignition (Option)	36
Convection-Oven Blower Runs Intermittently	37
Convection-Oven Blower Does Not Run	38
Wiring Diagram for 120V Oven Bases with Electronic Ignition	40
Wiring Diagram for Oven Base with Standing Pilot	41

TROUBLESHOOTING BROILER

The following table lists the possible causes of oven-related problems that may occur

Problem	Look for - 1
Not enough heat	<ul style="list-style-type: none"> - Restriction in valve. - Restriction in gas supply. - Misalignment of orifice tube. - Clogged orifice. - Incorrect orifice. - Low pressure on gas supply. - Incorrect gas type.
Too much heat	<ul style="list-style-type: none"> - Incorrect orifice. - Defective or incorrectly set pressure regulator. - Incorrect gas type.
Slow burner ignition	<ul style="list-style-type: none"> - Incorrect pilot flame length. - Incorrect pilot alignment. - Clogged pilot orifice.
Pilot will not remain lit	<ul style="list-style-type: none"> - Clogged pilot orifice. - Draft condition. - Incorrect pilot orifice. - Incorrectly adjusted pilot. - Air in gas line.
No gas to burner	<ul style="list-style-type: none"> - Gas supply is turned off.

TROUBLESHOOTING OVEN

CAUTION

Proper and efficient operation of oven is dependent on correct installation and function of components. Always verify that components are in place and functioning as intended.

The following table lists the possible causes of oven-related problems that may occur

Problem	Look for - 1
Oven will not come on.	<ul style="list-style-type: none"> - Oven gas shut-off valve is OFF - Power switch is OFF - Problem with power switch - Problem with pilot solenoid - Problem with main gas solenoid - Problem with wiring - Problem with spark ignition module - Problem with flame sensor switch
Oven pilot will not light	<ul style="list-style-type: none"> - Oven gas shut-off valve is OFF - Problem with power switch - Problem with pilot solenoid - Problem with wiring - Problem with spark ignition module
Convection blower motor will not run	<ul style="list-style-type: none"> - Problem with fan speed switch - Problem with door switch - Problem with blower motor - Problem with wiring
Oven will not maintain set temperature	<ul style="list-style-type: none"> - Problem with oven thermostat - Problem with door switch
Oven door too difficult to lift	<ul style="list-style-type: none"> - Problem with door spring - Problem with door roller assembly

SERVICING CONVECTION OVEN BLOWER MOTOR

WARNING

Before attempting to service or replace any electrical component, make sure that the power source has been disconnected.

CAUTION

When changing motor or servicing unit, always verify that blower wheel rotation is clockwise when looking into the oven cavity.

The motor is serviceable from the front of the unit through the oven cavity.

Motor lubrication information can be found on the permanent label located on the motor.

If the blower does not run at all, consult the wiring diagrams in this manual (beginning Figure 17), or behind the oven kick plate.

If the blower runs intermittently, consult the corresponding flowchart. (See Figure 14).

TROUBLESHOOTING BASE OVEN

! CAUTION

Proper and efficient operation of oven is dependent on correct installation and function of components. Always verify that components are in place and functioning as intended.

Consult the following table and the flowchart that begins on the following page.

Problem	Look for -
Oven will not come on.	- Oven pilot is out.
Oven pilot will not stay ignited	- Pilot gas not adjusted properly. - Bad thermopile. - Bad thermopile connections at safety valve. - Bad safety valve. - Clogged orifice. - Dirty pilot - Draft condition. - Improper ventilation system. - Air in gas line.

Figure 12

Troubleshooting Oven Pilot

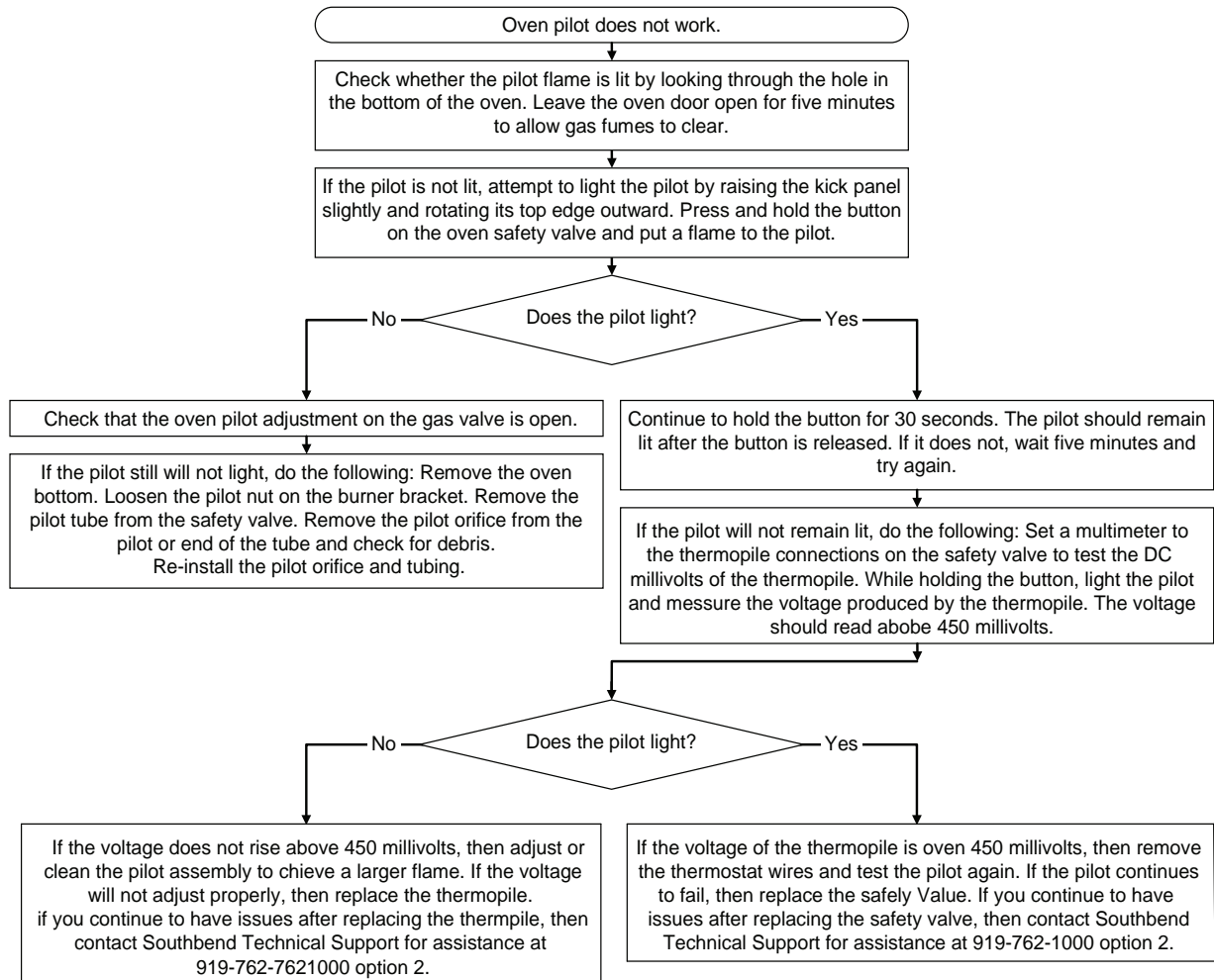
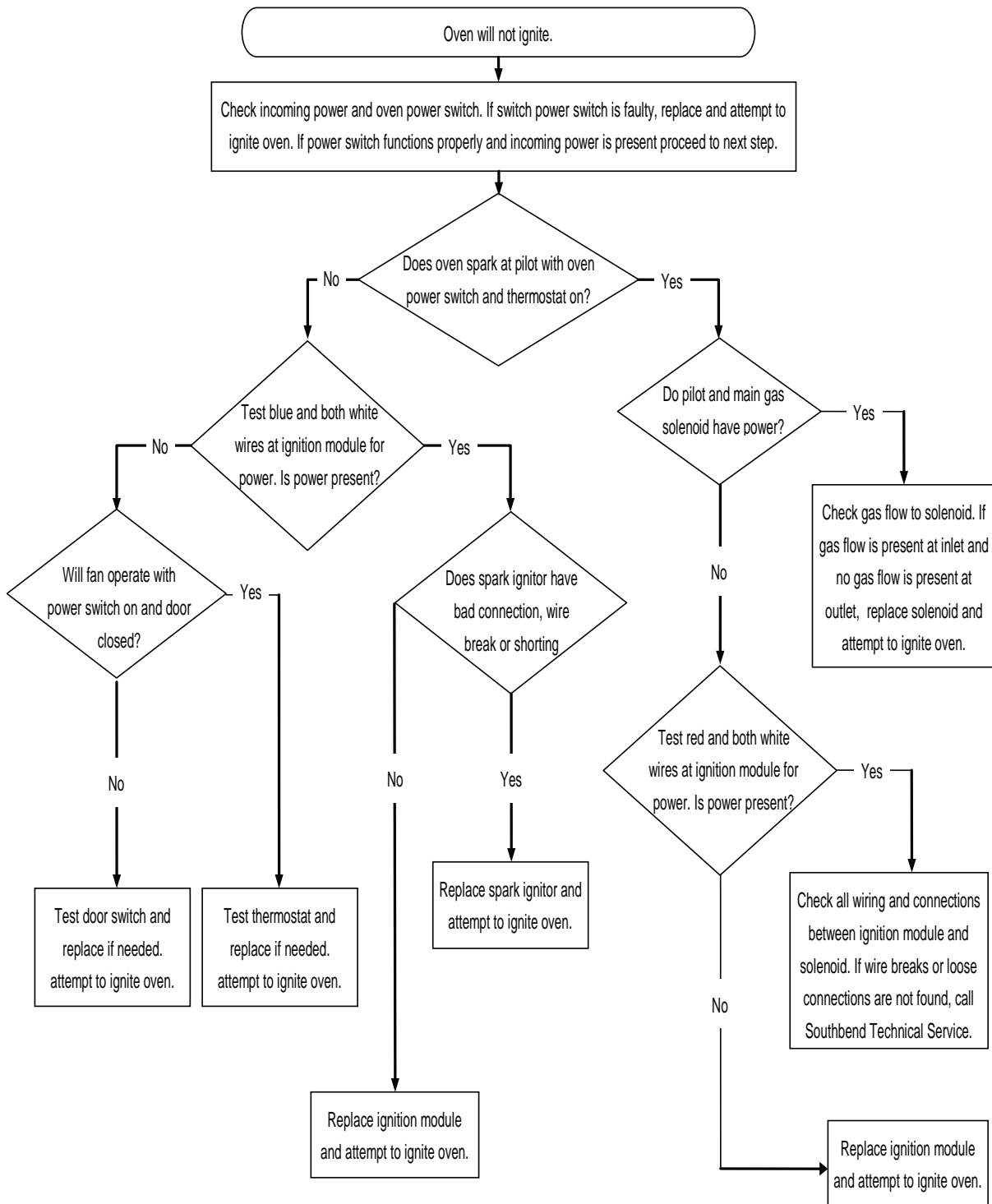

Figure 13

120 Volt Electronic Ignition (Option)



TROUBLESHOOTING CONVECTION-OVEN BLOWER

⚠ WARNING

Before attempting to service or replace any electrical component, make sure power source has been disconnected.

⚠ CAUTION

When changing motor or servicing oven, always verify that blower wheel rotation is clockwise when looking into the oven cavity.

If the blower does not run at all, consult the flowchart that begins on the next page. If the blower runs intermittently, consult the flowchart on this page.

The appropriate wiring diagram for the oven can be found on the rear of the oven (as well as at the end of this section of this manual).

Figure 14

Convection-Oven Blower Runs Intermittently

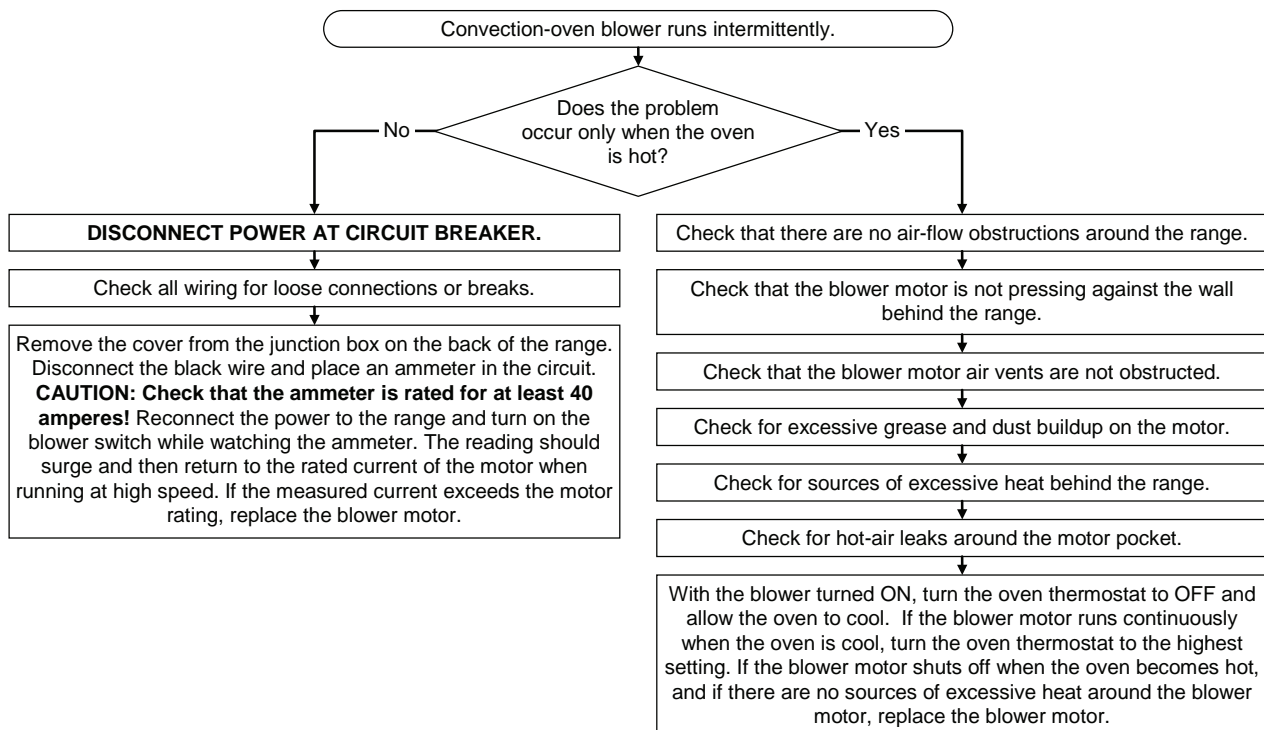

Figure 15

Convection-Oven Blower Does Not Run

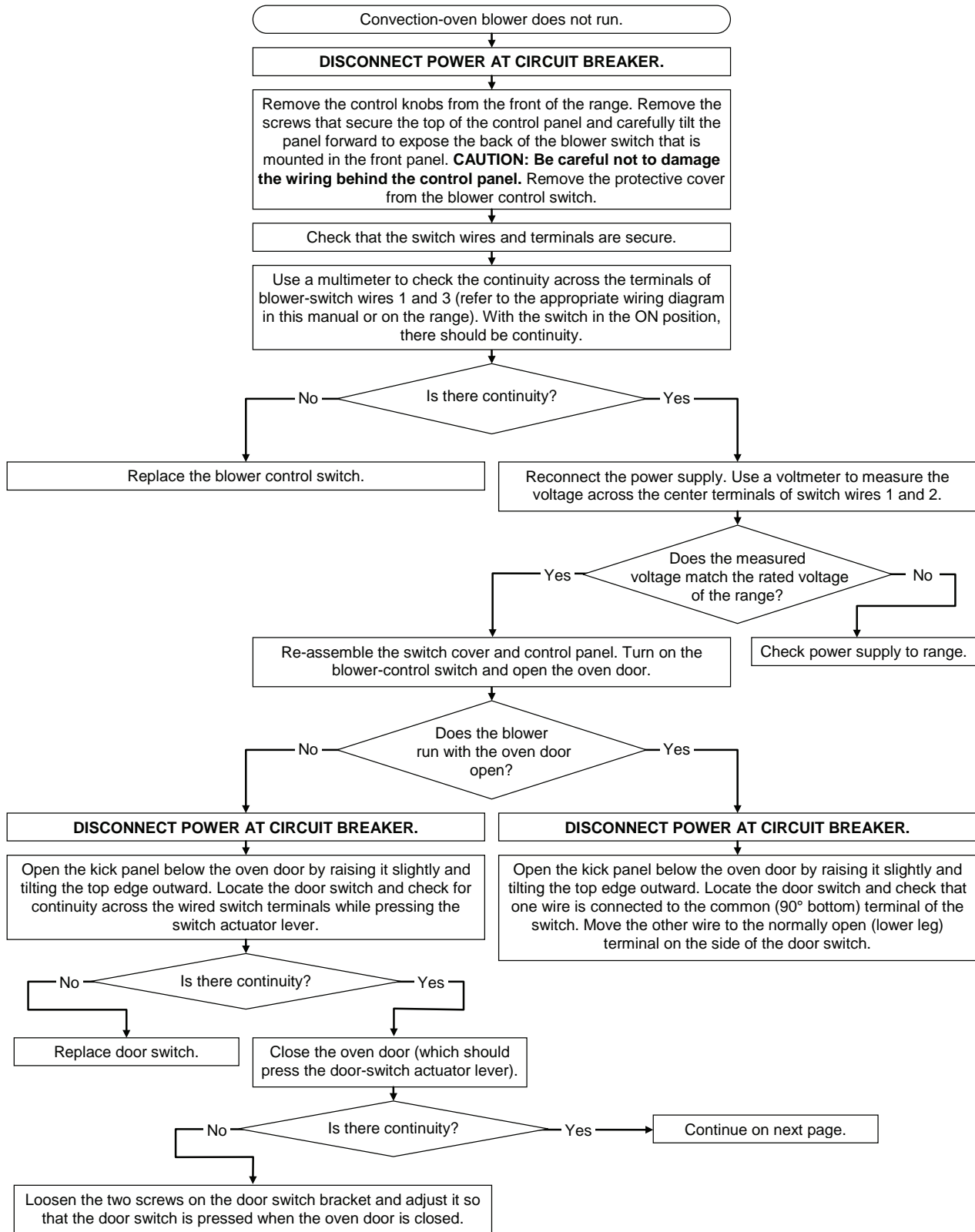

Figure 16

Convection-Oven Blower Does Not Run, Continued

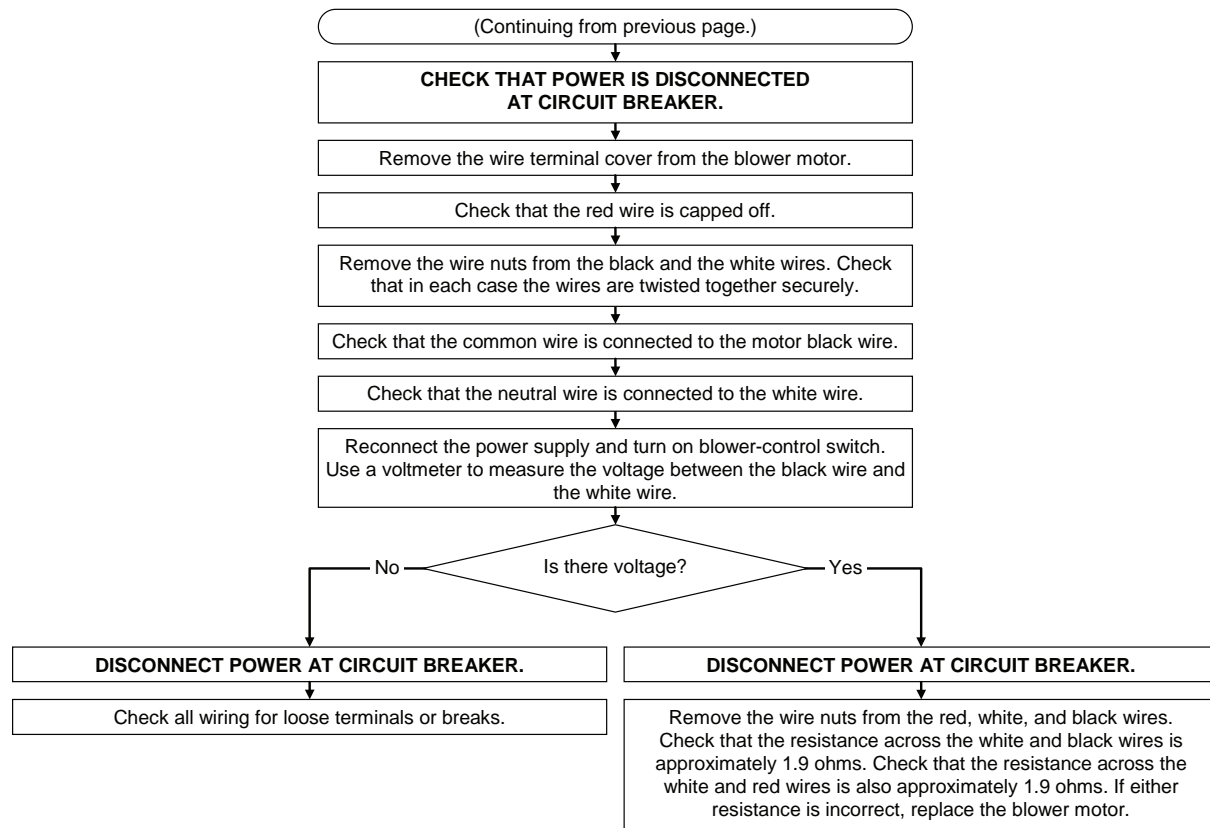

Figure 17

Wiring Diagram for 120 Volt Oven Bases with Electronic Ignition

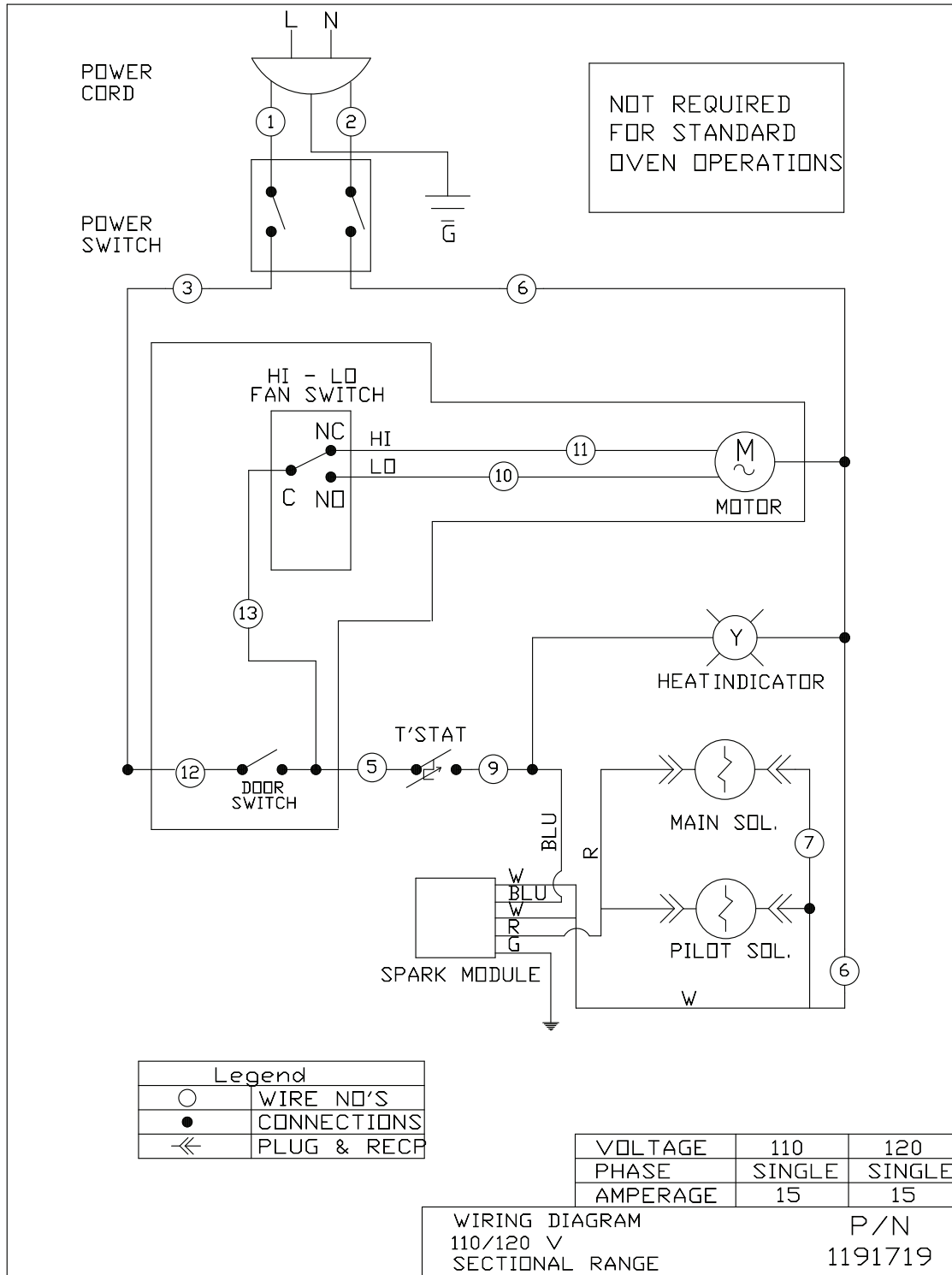

Figure 18

Wiring Diagram for Oven Base with Standing Pilot

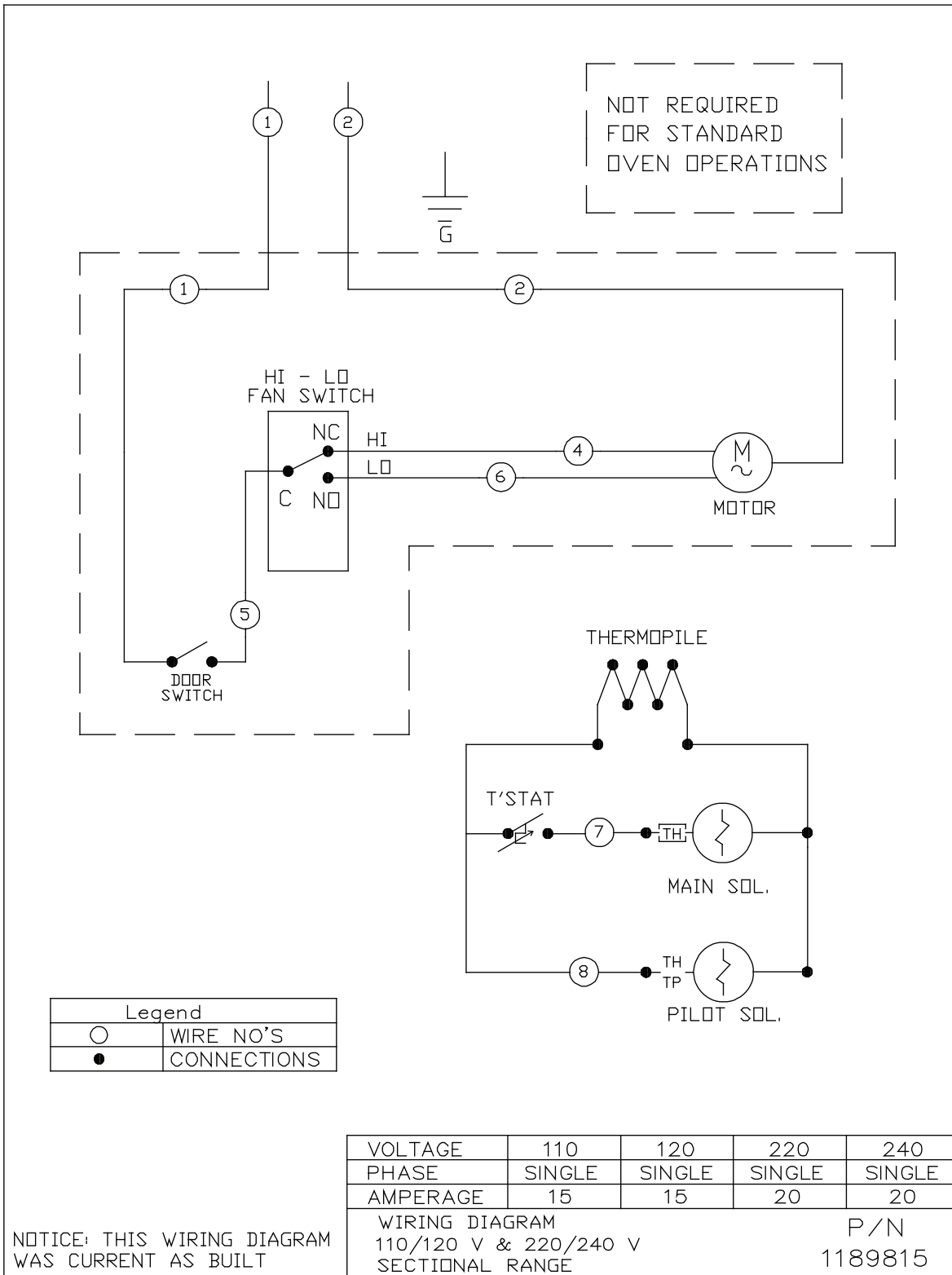
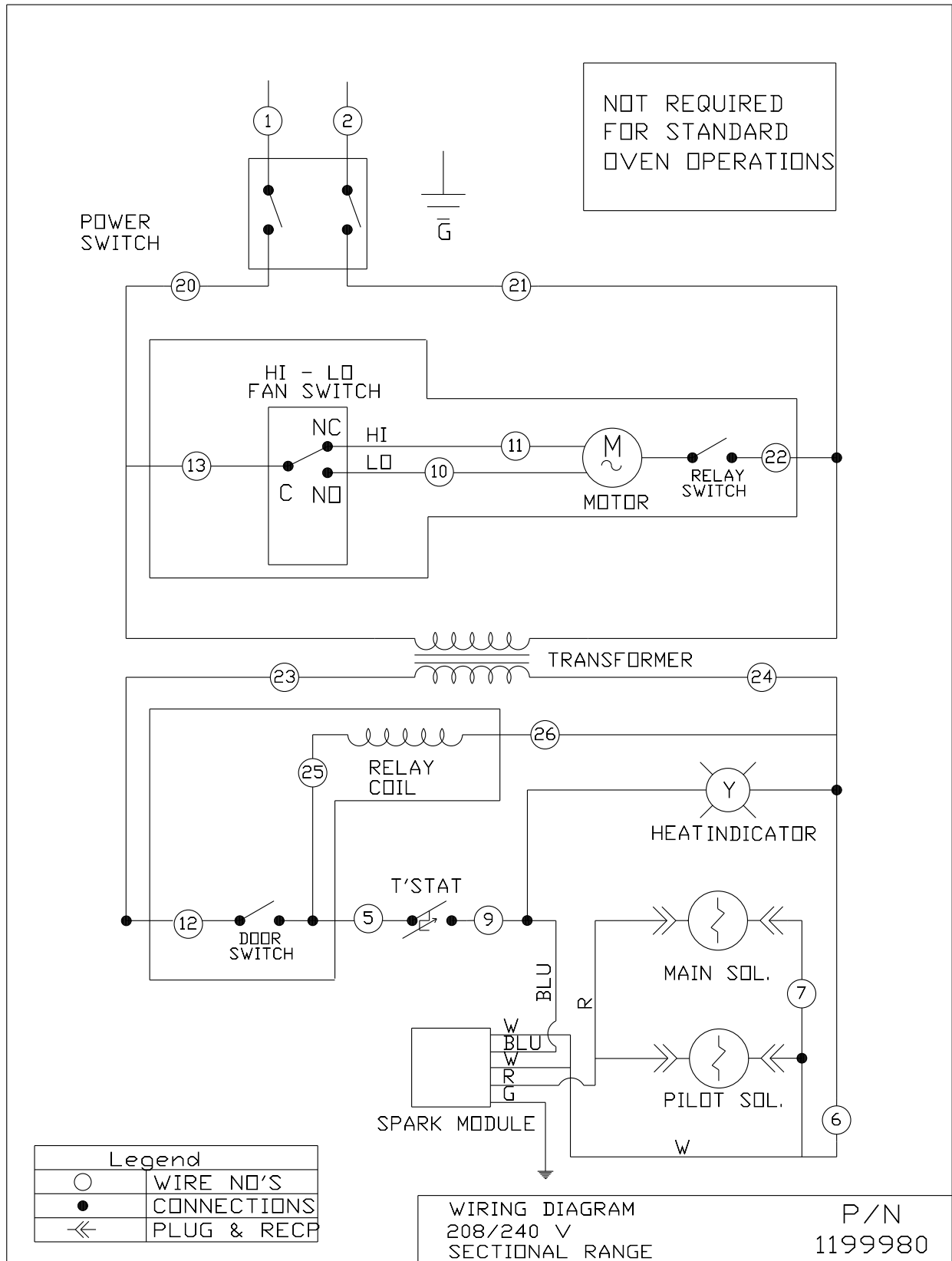

Figure 19

Wiring Diagram 240V Oven Base with Electronic Ignition



Notes:

Notes:

RADIANT BROILERS



A product with the Southbend name incorporates the best in durability and low maintenance. We all recognize, however, that replacement parts and occasional professional service may be necessary to extend the useful life of this appliance. When service is needed, contact a Southbend Authorized Service Agency, or your dealer. To avoid confusion, always refer to the model number, serial number, and type of your appliance.



Southbend
1100 Old Honeycutt Road Fuquay-Varina, North Carolina 27526 USA
www.southbendnc.com