

## 1. External Parts

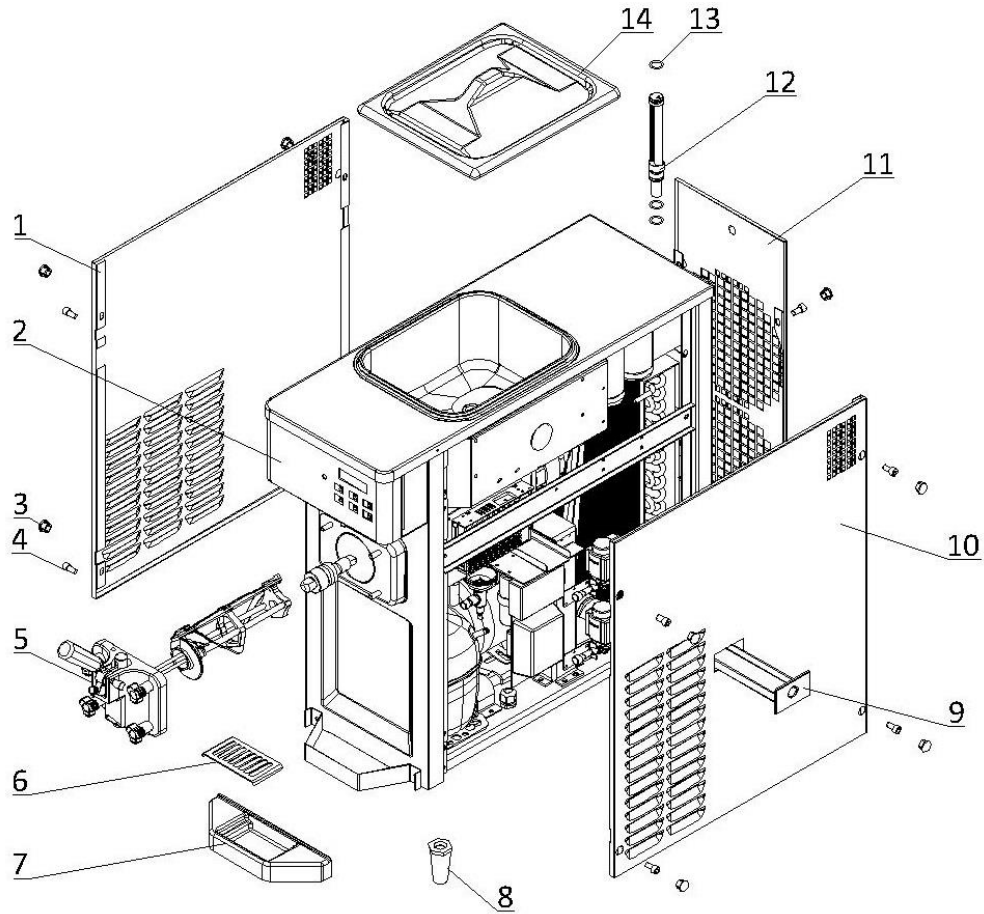

## 1. External Parts

Item	Part Number	Description	Qty.
1	<a href="#">2.3.4.28.026</a>	Panel - Left - 6210-C	1
2	Page 6	Draw Switch and Front Control Panel	1
3	3.4.07.01.001	Bolt Hole Cover	12
4	3.6.11.041	Panel Screw - M8x16	12
5	Page 5	Dispensing Door and Beater	1
6	2.3.6.03.024	Splash Shield - Front Drip Tray - 25.5 mm	1
7	<a href="#">3.4.04.01.004</a>	Front Drip Tray - 25.5 mm	1
8	3.3.05.03.005	Leg - 68mm	4
9	<a href="#">3.4.04.02.003</a>	Internal Drip Tray - 25mm	1
10	<a href="#">2.3.4.30.025</a>	Panel - Right - 6210-C	1
11	<a href="#">2.3.4.23.044</a>	Panel - Rear - 6210-C	1
12	<a href="#">2.1.3.39.0010</a>	Air Tube - SS - Short - V3	1
13	3.4.08.01.002	O-Ring - 18x2.2	3
14	<a href="#">3.4.03.01.001</a>	Hopper Lid - 8L	1

**2. Internal Parts**

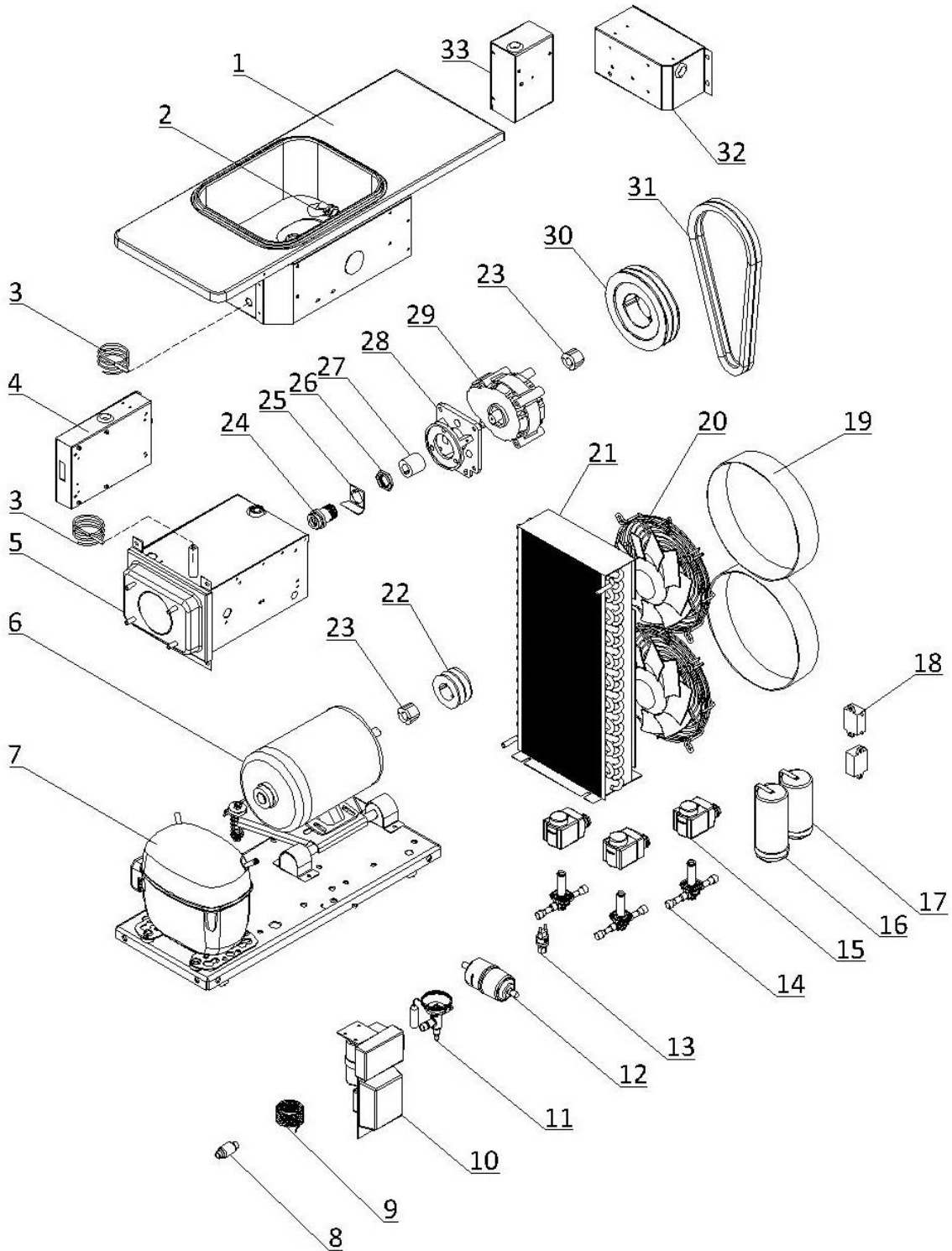

## 2. Internal Parts

Item	Part Number	Description	Qty.
1	2.1.1.02.0061	Hopper Assembly - 6210-C	1
2	920.1.04.0002	Mix Low Sensor Assembly	1
3	3.1.02.13.020	Temperature Probe - PT100 (With Cap-φ6)	2
4	Page 7	Control Box	1
5	2.1.1.06.0115	Cylinder Assembly - 6210-C	1
6	3.3.01.07.011	Motor - 115/60/1 - 450W - K56AC67F41	1
7	3.2.01.02.028.A	Primary Compressor - SC18CLX.2	1
8	3.2.04.05.009	Copper Strainer Filter - φ9.52	1
9	3.2.05.01.008	Capillary Tube - 2.07×1.07	1
10	3.2.01.04.014	Start Component - Compressor - SC18CLX.2	1
11	3.2.04.01.001	Thermal Expansion Valve - T2	1
12	3.2.04.05.002	Filter Drier - Cylinder - DML083S	1
13	3.2.04.06.004	High Pressure Switch - 350~500psi	1
14	3.2.04.04.001	Solenoid Valve Body - EVR6 - 10W	3
15	3.2.04.04.016	Solenoid Coil - AC110V	3
16	3.1.02.22.063	Capacitor - Start - 165V - 416.5μF	1
17	3.1.02.22.010	Capacitor - Running - 370V - 50μF	1
18	3.2.03.04.007-2	Capacitor - Fan Motor - 450V - 5μF - MKPS	2
19	2.1.3.50.0074	Fan Shroud - 75 mm	2
20	3.2.03.04.007	Fan Motor - 110-60-1 - YWF4E200S-92/15-GBB-01	2
21	3.2.02.01.023	Main Condenser - Single - 5m <sup>2</sup> - 6210-C	1
22	3.3.04.02.001	Pulley - Beater Motor - SPA63-2-1008	1
23	3.3.04.01.005	Bushing - 1008-16	2
24	3.3.02.02.001	Rear Shell Bearing - SS - 1.3/1.8qt	1
25	2.3.6.04.029	Lock Plate - Rear Shell Bearing - 39mm	1
26	3.3.02.02.010	Nut - Rear Shell Bearing	1
27	3.3.02.04.005	Coupling Drive - 1.3-1.8qt - 20mm	1
28	2.1.3.15.0009	Bracket - Gear Box - 1.3-1.8qt - 89mm	1
29	3.3.02.01.025	Gear Box - SS - 75*20 Shaft - 89mm	1
30	3.3.04.02.021	Pulley - SPA155-2-1008	1
31	3.3.03.01.022	Belt - Motor to Beater - V-XPA850	1
32	Page 8	Electrical Box #1	1
33	Page 9	Electrical Box #2	1

### 3. Dispensing Door and Beater

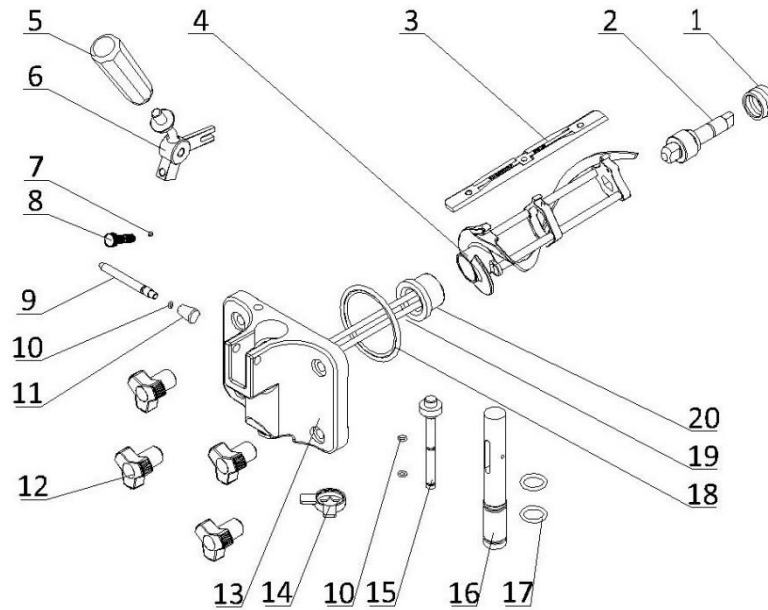

Item	Part Number	Description	Qty.
1	<a href="#">3.4.07.05.002</a>	Gasket - Drive Shaft	1
2	<a href="#">2.1.3.25.0001</a>	Drive Shaft - SS - 1.3-1.8qt	1
3	<a href="#">3.4.02.01.004</a>	Scraper Blade - Large - V2	1
4	<a href="#">2.1.1.10.0019</a>	Beater - SS - Small - 1.3qt - V2	1
5	<a href="#">3.4.05.01.001</a>	Handle - Dispensing - SS	1
6	<a href="#">2.1.3.26.0004</a>	Seat - Handle - 1F - 1.3-1.8qt	1
7	3.4.08.01.012	O-Ring - 3x1.5	1
8	3.6.39.008	Adjustment Screw - Handle - 34mm	1
9	<a href="#">2.1.3.27.0001</a>	Retention Pin - Handle - 1F - 1.3-1.8qt	1
10	3.4.08.01.013	O-Ring - 5.2x1.9	3
11	2.1.3.27.0025	Nut - Retention Pin - Handle	1
12	3.4.05.02.012	Hand Screw - Small - Dispensing	4
13	2.1.3.14.0002	Dispensing Door - SS - 1F - 1.3-1.8qt	1
14	3.4.05.03.004	Design Cap - Double Triangle - 31mm	1
15	2.1.3.02.0015	Prime Plug - SS - Standard	1
16	<a href="#">2.1.3.01.0013</a>	Draw Valve - SS - 1F - 6210/6220	1
17	3.4.08.01.006	O-Ring - 16.8x2.4	2
18	3.4.08.02.007	Door Gasket - SS - 1.3-1.8qt	1
19	2.1.1.11.0003	Beater Rod - SS - Small - 1.3qt (With O-ring)	1
20	3.4.01.03.007	Beater Guide - SS - 1.3-1.8qt - V2	1

## 4. Draw Switch and Front Control Panel

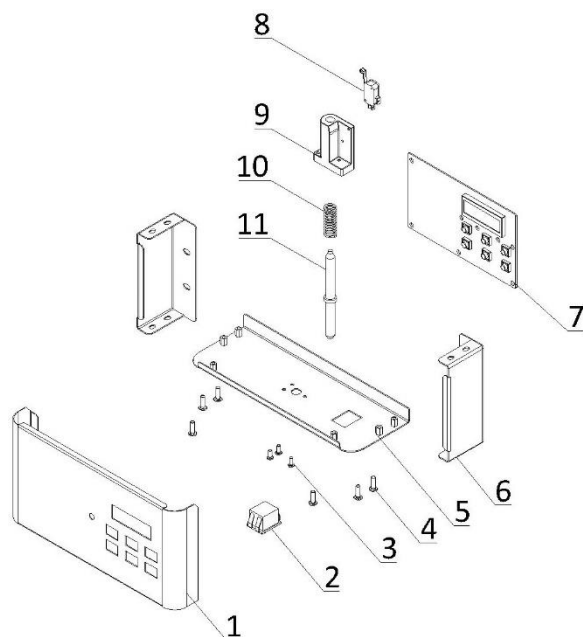

Item	Part Number	Description	Qty.
<b>1</b>	<a href="#">2.3.4.36.033</a>	Panel - Overhead Front - 6210-C 430	<b>1</b>
<b>2</b>	<a href="#">3.1.03.03.003</a>	Power Switch - KCD2-2	<b>2</b>
<b>3</b>	3.6.22.005	Screw - M4×10	<b>3</b>
<b>4</b>	3.6.22.011	Screw - M5×16	<b>6</b>
<b>5</b>	<a href="#">2.3.4.39.052</a>	Panel - Overhead Bottom - 6210-C	<b>1</b>
<b>6</b>	<a href="#">2.3.4.37.041</a>	Panel - Overhead Left & Right - 6210-C	<b>2</b>
<b>7</b>	<a href="#">920.1.01.0006</a>	Control Board - SS - V2.152 - Horizontal - V2	<b>1</b>
<b>8</b>	<a href="#">3.1.03.01.002</a>	Micro Switch - KW-7-2	<b>1</b>
<b>9</b>	<a href="#">3.4.07.06.008</a>	Bracket - Micro Switch & Shaft & Spring	<b>1</b>
<b>10</b>	<a href="#">3.6.03.012</a>	Spring - Shaft - Draw Switch	<b>1</b>
<b>11</b>	<a href="#">2.1.3.50.0073</a>	Shaft - Draw Switch - 6210-C	<b>1</b>

## 5. Control Box

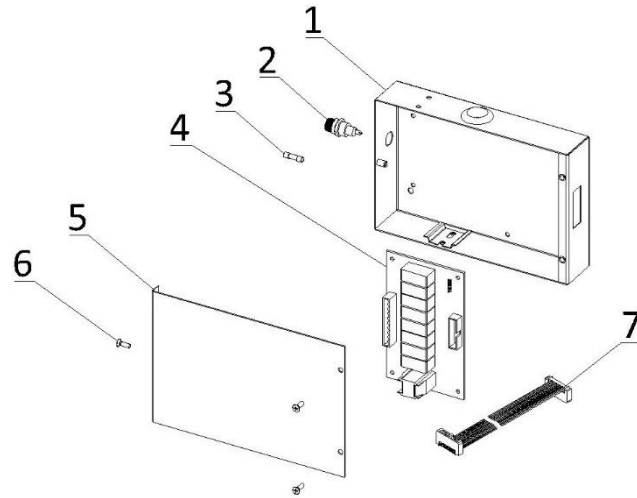

Item	Part Number	Description	Qty.
1	2.2.4.17.0088	Control Box - 6210-C	1
2	<a href="#">3.1.02.08.012</a>	Seat - Fuse - 250V	1
3	<a href="#">3.1.02.08.001</a>	Fuse - 1A	1
4	<a href="#">2.2.1.01.0007</a>	Power Board - SS - V2.152	1
5	2.2.4.20.0076	Cover - Control Box - 6210-C	1
6	3.6.19.002	Screw - M4×10	3
7	<a href="#">3.1.04.01.003</a>	Ribbon Cable - 20 Pin	1

## 6. Electrical Box 1

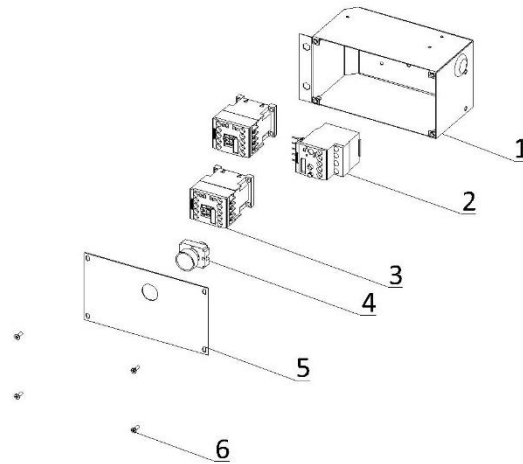

Item	Part Number	Description	Qty.
1	2.2.4.17.0087	Electrical Box 1 - 6210-C	1
2	<a href="#">3.1.01.02.012</a>	Thermal Overload Relay - 3RU6116-1HB0	1
3	<a href="#">3.1.01.01.011</a>	Contactor - 3RT6017-1AF01	2
4	<a href="#">3.1.03.04.002</a>	Reset Button - Thermal Overload	1
5	2.2.4.20.0075	Cover - Electrical Box 1 - 6210-C	1
6	3.6.19.002	Screw - M4×10	4

## 7. Electrical Box 2

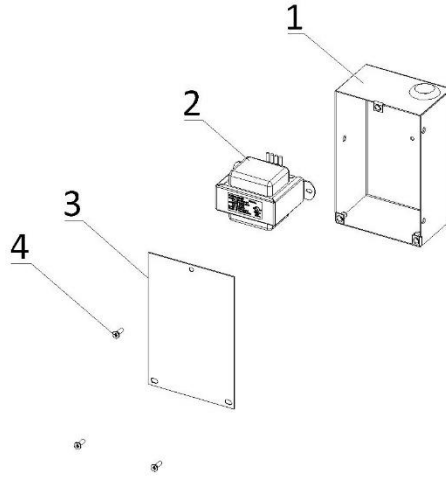

Item	Part Number	Description	Qty.
1	2.2.4.17.0089	Electrical Box 2 - 6210-C	1
2	<a href="#">3.1.01.04.007</a>	Transformer - 50W - 50313MW232	1
3	2.2.4.20.0077	Cover - Electrical Box 2 - 6210-C	1
4	3.6.19.002	Screw - M4×10	3