

1. External Parts

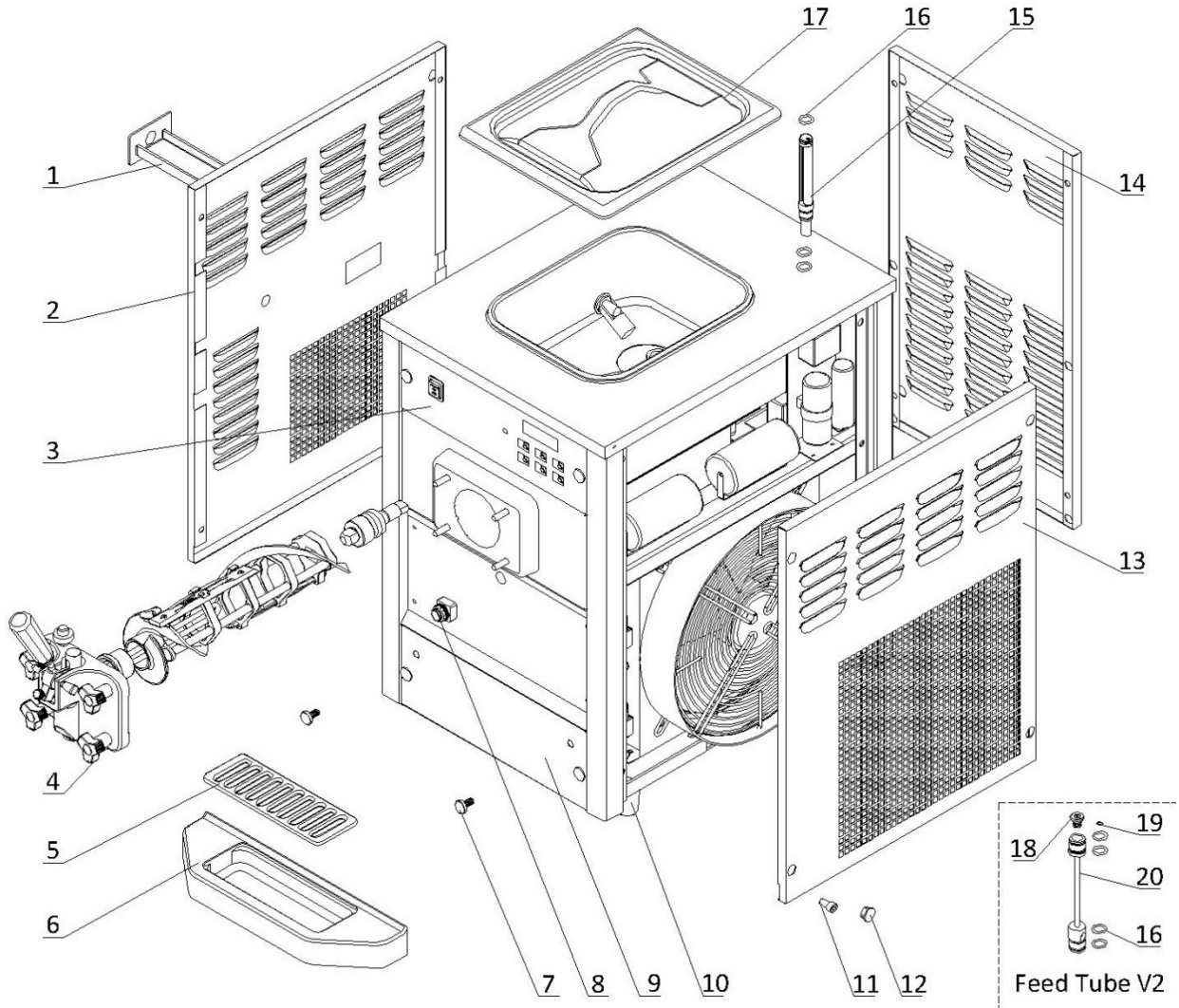

1. External Parts

Item	Part Number	Description	Qty.
1	3.4.04.02.003	Internal Drip Tray - 25mm	1
2	2.3.4.18.001	Panel - Left - 6220	1
3	2.3.4.07.001	Panel - Draw Switch - 6220	1
4	Page 5	Dispensing Door and Beater	1
5	3.4.04.01.002-1	Splash Shield - Front Drip Tray - 37.2mm	1
6	3.4.04.01.002	Front Drip Tray - 37.2mm	1
7	3.6.39.004	Drip Tray Mounting Bolt	2
8	3.1.03.04.004	Draw Switch Sensor - R18-10PB-OND	1
9	2.3.4.17.002	Panel - Lower Front - 6220	1
10	3.3.05.03.001	Leg - 45mm	4
11	3.6.11.041	Screw - Hex - Socket - M8x16	16
12	3.4.07.01.001	Bolt Hole Cover	16
13	2.3.4.20.001	Panel - Right - 6220	1
14	2.3.4.13.001	Panel - Rear - 6220	1
15	2.1.3.39.0010	Air Tube - SS - Short - V3	1
16	3.4.08.01.002	O-Ring - 18x2.2	3
17	3.4.03.01.001	Hopper Lid - 8L	1
18	2.1.3.23.0001	Air Tube Cap - SS - Small (Old Version)	1
19	3.4.08.01.028	O-Ring - 6.2x1.9 (Old Version)	1
20	3.4.07.04.021	Air Tube - SS - Short - V2 (Old Version)	1

2. Internal Parts

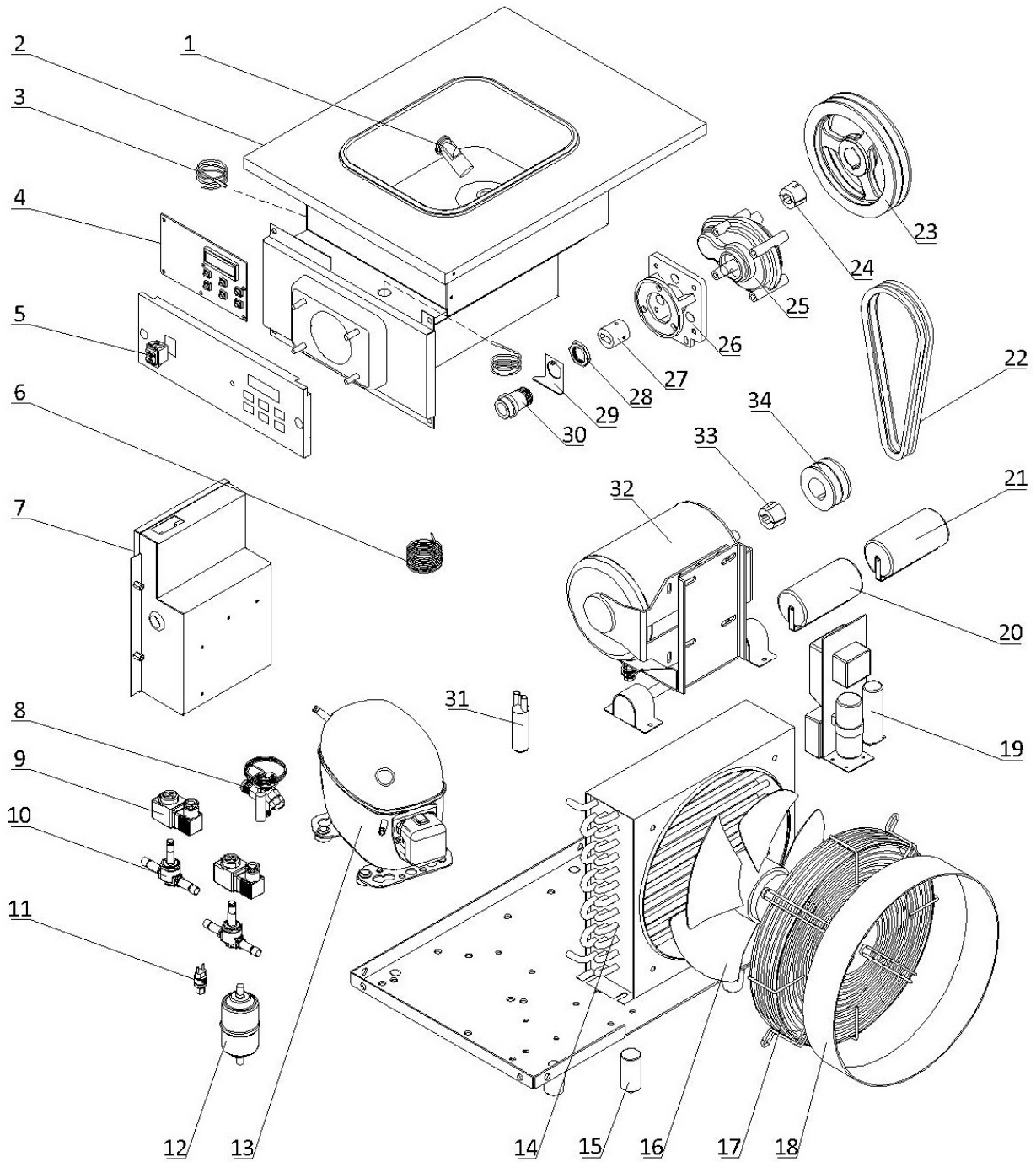

2. Internal Parts

Item	Part Number	Description	Qty.
1	920.1.04.0002	Mix Low Sensor Assembly	1
2	2.1.1.01.0023	Hopper & Cylinder Assembly - 6220	1
3	3.1.02.13.020	Temperature Probe - PT100	2
4	2.2.1.01.0009-1	Control Board - SS - V2.152 - 6220	1
5	3.1.03.03.003	Power Switch - KCD2-2	1
6	3.2.05.01.008	Capillary Tube - 2.07×10.7 (Since 192156)	1
7	Page 6	Electrical Box	1
8	3.2.04.01.014	Thermal Expansion Valve - TUB2129 (Since 192148)	1
9	3.2.04.04.016	Solenoid Coil - EVR6	2
10	3.2.04.04.001	Solenoid Valve Body - EVR6	2
11	3.2.04.06.004	High Pressure Switch - 350~500psi	1
12	3.2.04.05.002	Filter Drier - Cylinder - DML083S	1
13	3.2.01.02.028.A	Primary Compressor - SC18CLX.2	1
14	3.2.02.01.003	Main Condenser - Single - 5m ² - 375x325x100	1
15	3.2.03.04.003-2	Capacitor - Fan Motor - 450V - 10μF - CBB60	1
16/17	3.2.03.04.003	Fan Motor - 110-60-1 - YWF4E-300S	1
18	2.1.3.50.0001	Fan Shroud - 155mm	1
19	3.2.01.04.014	Start Component - Compressor - SC18CLX.2	1
20	3.1.02.22.063	Capacitor - Start - 165V - 416.5μF	1
21	3.1.02.22.010	Capacitor - Running - 370V - 50μF	1
22	3.3.03.01.019	Belt - Motor to Beater - V-XPA900	2
23	3.3.04.02.007	Pulley - Gear Box - SPA182-2-1008	1
24	3.3.04.01.005	Bushing - 1008-16	1
25	3.3.02.01.023	Gear Box - SS - 45*20 Shaft - 89mm (Since 190181)	1
26	2.1.3.15.0009	Bracket - Gear Box - 1.3-1.8qt - 89mm	1
27	3.3.02.04.005	Coupling Drive - 1.3-1.8qt - 20mm	1
28	3.3.02.02.010	Nut - Rear Shell Bearing	1
29	2.3.6.04.029	Lock Plate - Rear Shell Bearing - 39mm	1
30	3.3.02.02.001	Rear Shell Bearing - SS - 1.3/1.8qt	1
31	3.2.04.07.002	Suction Accumulator - 30×155×10	1
32	3.3.01.07.011	Motor - 115/60/1 - 450W - K56AC67F41	1
33	3.3.04.01.006	Bushing - 1108-16	1
34	3.3.04.02.003	Pulley - Beater Motor - SPA71-2-1108	1

3. Dispensing Door and Beater Assembly

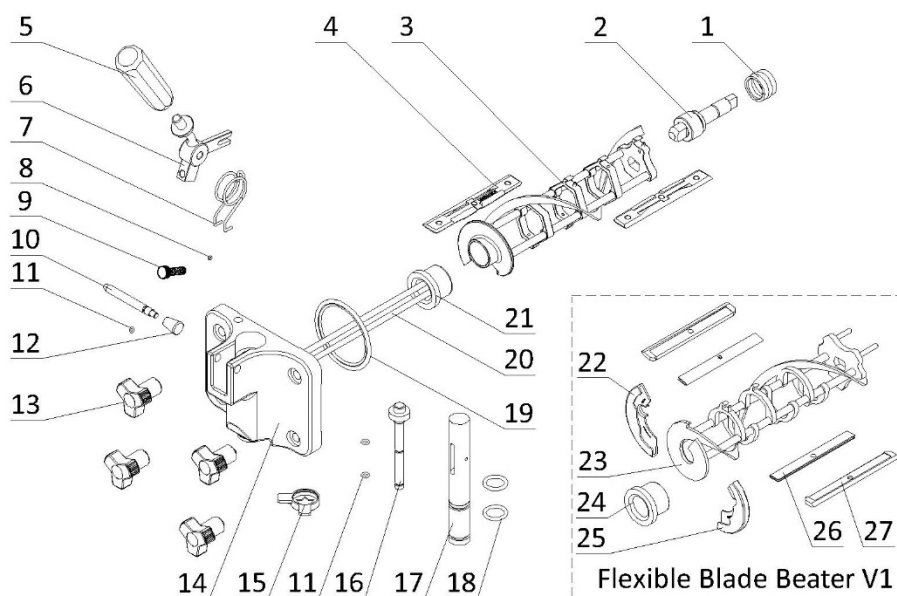

Item	Part Number	Description	Qty.
1	3.4.07.05.002	Gasket - Drive Shaft	1
2	2.1.3.25.0001	Drive Shaft - SS - 1.3-1.8qt	1
3	2.1.1.10.0017	Beater - SS - Medium - 1.8qt - V2	1
4	3.4.02.01.005	Scraper Blade - Small - V2	2
5	3.4.05.01.001	Handle - Dispensing - SS	1
6	2.1.3.26.0004	Seat - Handle - 1F - 1.3-1.8qt	1
7	3.6.03.011	Spring - Handle - 6210/6220	1
8	3.4.08.01.012	O-Ring - 3x1.5	1
9	3.6.39.009	Adjustment Screw - Handle - 22mm	1
10	2.1.3.27.0001	Retention Pin - Handle - 1F - 1.3-1.8qt	1
11	3.4.08.01.013	O-Ring - 5.2x1.9	3
12	2.1.3.27.0025	Nut - Retention Pin - Handle	1
13	3.4.05.02.012	Hand Screw - Small - Dispensing	1
14	2.1.3.14.0002	Dispensing Door - SS - 1F - 1.3-1.8qt	1
15	3.4.05.03.004	Design Cap - Double Triangle - 31mm	1
16	2.1.3.02.0015	Prime Plug - SS - Standard	1
17	2.1.3.01.0013	Draw Valve - SS - 1F - 6210/6220	1
18	3.4.08.01.006	O-Ring - 16.8x2.4	2
19	3.4.08.02.007	Door Gasket - SS - 1.3-1.8qt	1
20	2.1.1.11.0001	Beater Rod - SS - 1.8qt	1
21	3.4.01.03.007	Beater Guide - SS - 1.3-1.8qt - V2	1
22	3.4.01.01.002	Shoe - Left Small - 1.3-1.8qt (Old Version)	1
23	2.1.1.10.0002	Beater - SS - Medium - 1.8qt (Old Version)	1
24	3.4.01.03.001	Beater Guide - SS - 1.3-1.8qt (Old Version)	1
25	3.4.01.02.002	Shoe - Right Small - 1.3-1.8qt (Old Version)	1
26	2.3.4.04.001	Clip - Scraper Blade - 1.8qt (Old Version)	1
27	3.4.02.01.002	Plastic - Scraper Blade - 1.8qt (Old Version)	1

4. Electrical Box

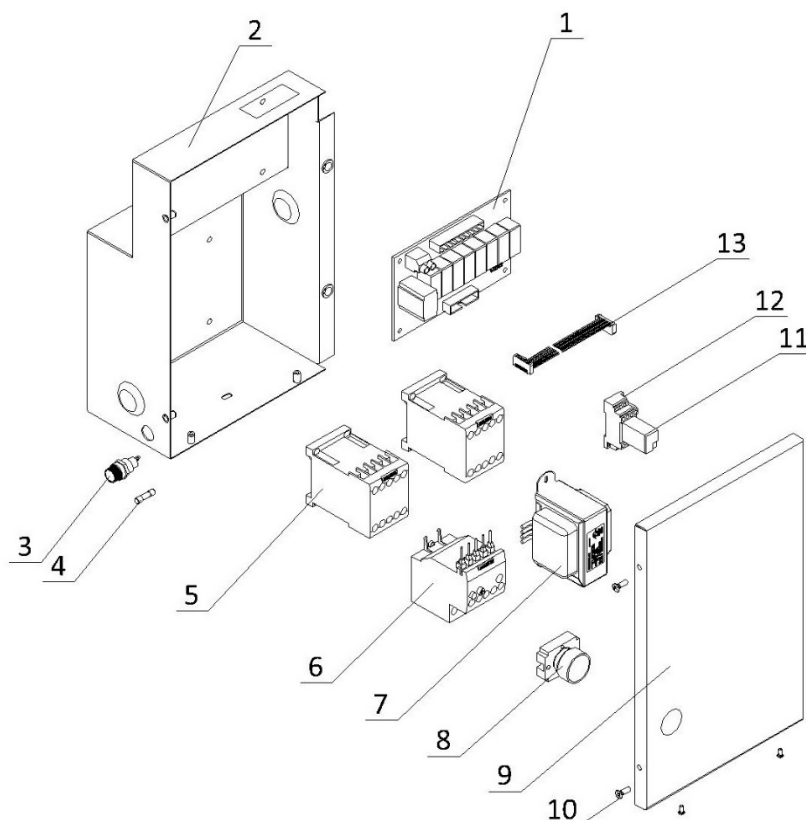

Item	Part Number	Description	Qty.
1	2.2.1.01.0007	Power Board - SS - V2.152	1
2	2.2.4.17.0004	Electrical Box - 6220	1
3	3.1.02.08.012	Seat - Fuse - 250V	1
4	3.1.02.08.001	Fuse - 1A	1
5	3.1.01.01.011	Contactor - 110V - 3RT6017-1AF01	2
6	3.1.01.02.012	Thermal Overload Relay - 3RU6116-1HB0	1
7	3.1.01.04.007	Transformer - 50W - 50313MW232	1
8	3.1.03.04.002	Reset Button - Thermal Overload	1
9	2.2.4.20.0004	Cover - Electrical Box - 6220	1
10	3.6.19.001	Screw - M4×8	4
11	3.1.01.03.032	Intermediate Relay - AC110V - HH54P-L	1
12	3.1.01.03.031	Base - Relay - TP514X1-E	1
13	3.1.04.01.003	Ribbon Cable - 20 Pin	1