

1. External Parts

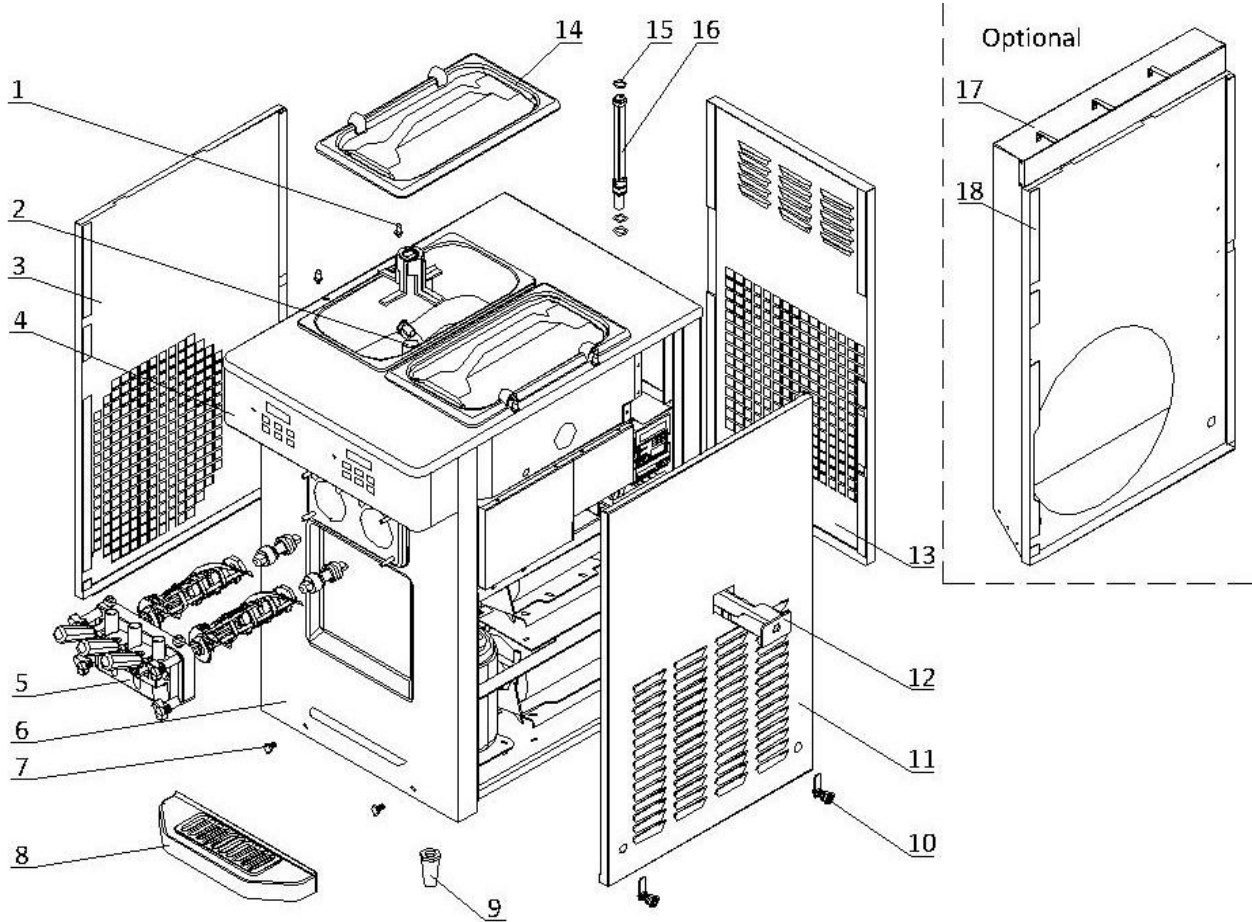

1. External Parts

Item	Part Number	Description	Qty.
1	3.6.39.011	Hopper Lid Holder	4
2	Page 7	Hopper Agitator	2
3	2.3.4.18.054	Panel - Left - 6235-C/6235A-C	1
4	Page 6	Draw Switch and Front Control Panel	1
5	Page 5	Dispensing Door and Beater	1
6	2.3.4.16.052	Panel - Lower Front - 6235-C/6235A-C	1
7	3.6.39.004	Drip Tray Mounting Bolt	2
8	3.4.04.01.002	Front Drip Tray - 37.2mm	1
9	3.3.05.03.005	Leg - 68mm	4
10	8.1.07.001	Panel Lock Assembly	12
11	2.3.4.20.045	Panel - Right - 6235-C/6235A-C	1
12	3.4.04.02.001	Internal Drip Tray - 45mm	1
13	2.3.4.13.044	Panel - Rear - 6235-C/6235A-C	1
14	3.4.03.01.004	Hopper Lid - 12-15L	2
15	2.1.3.39.0011	Air Tube - SS - Long - V3	2
16	3.4.08.01.002	O-Ring - 18x2.2	6
17	2.3.4.34.043	Air Chute - 6235-C/6235A-C (Optional)	1
18	2.3.4.18.059	Panel - Left - Air Chute - 6235-C/6235A-C (Optional)	1

2. Internal Parts

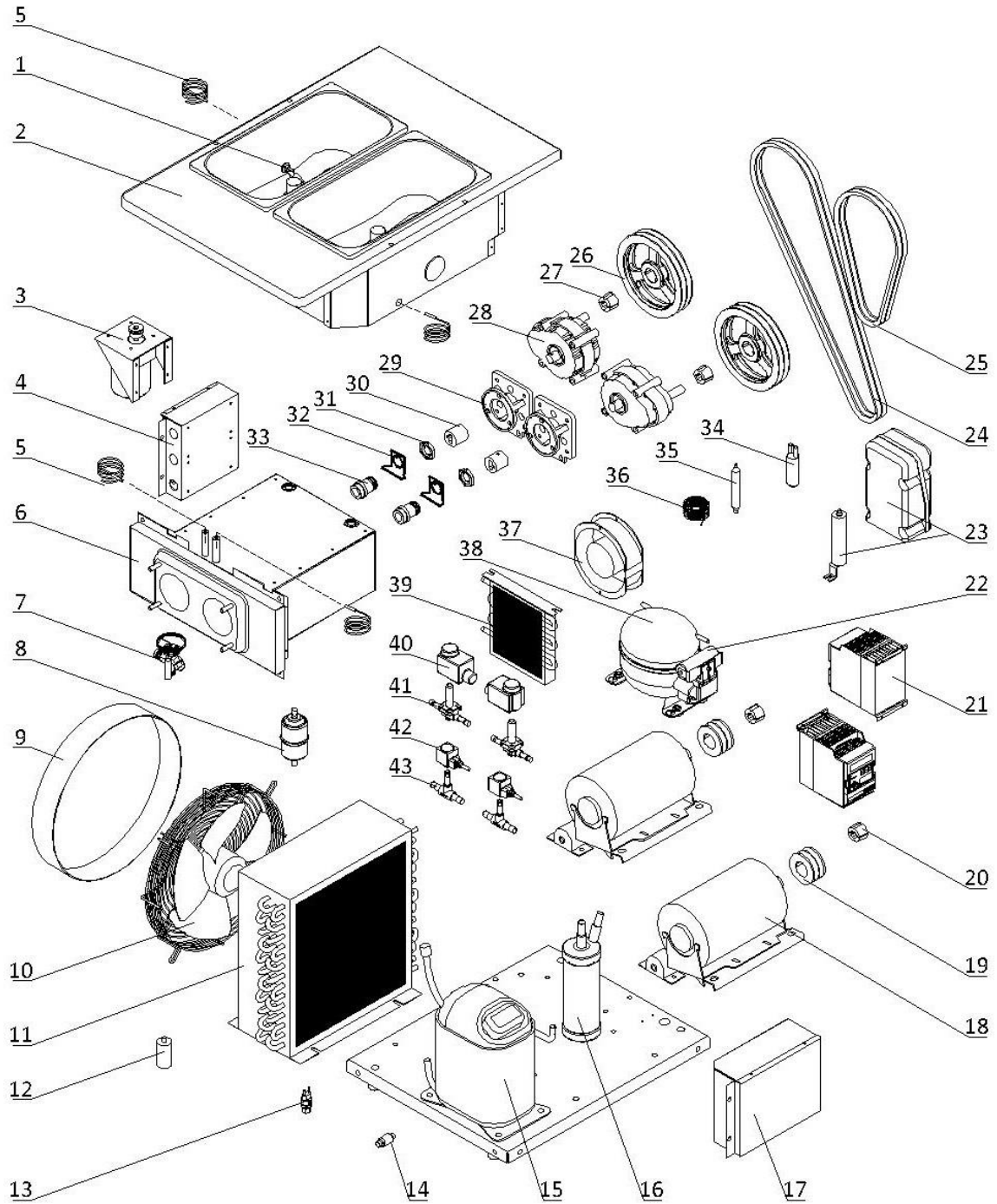

2. Internal Parts

Item	Part Number	Description	Qty.
1	920.1.04.0002	Mix Low Sensor Assembly	2
2	2.1.1.03.0054	Hopper Assembly - 6235-C/6250-C	1
3	Page 7	Agitator Motor Assembly	1
4	Page 8	Control Box	1
5	3.1.02.13.020	Temperature Probe - PT100	4
6	2.1.1.06.0104	Cylinder Assembly - 2F - 1.8qt	1
7	3.2.04.01.012	Thermal Expansion Valve - TUB2132	1
8	3.2.04.05.002	Filter Drier - Cylinder - DML083S	1
9	2.1.3.50.0002	Fan Shroud - 120mm	1
10	3.2.03.04.001	Fan Motor - 220/60/1 - YWF4E-350S	1
11	3.2.02.01.007	Main Condenser - Single - 10m ²	1
12	3.2.03.04.001-2	Capacitor - Fan Motor - 450V - 5μF - CBB60	1
13	3.2.04.06.004	High Pressure Switch - 350~500psi	1
14	3.2.04.05.010	Copper Strainer Filter - φ12	1
15	3.2.01.02.005.A	Primary Compressor - CAJ2464Z	1
	3.2.01.02.042.A	Primary Compressor - CAJ4519Z (Alternative)	1
16	3.2.04.08.001	liquid Receiver - 76x280	1
17	Page 9	Electrical Box	1
18	3.3.01.04.005	Motor - 750W/3Ph - P56AH60F41	2
19	3.3.04.02.003	Pulley - Beater Motor - SPA71-2-1108	2
20	3.3.04.01.006	Bushing - 1108-16	2
21	3.1.01.08.006	Inverter - 0.75kW - EFC3610-0K75-1P2-MDA	2
22	3.2.01.01.010-1	Start Component - Compressor - PL35G	1
23	3.2.01.04.004	Start Component - Compressor - CAJ2464Z	1
	3.2.01.04.024	Start Component - Compressor - CAJ4519Z (Alternative)	1
24	3.3.03.03.016	Belt - Motor to Beater - A1321	2
25	3.3.03.03.008	Belt - Motor to Beater - A750	2
26	3.3.04.02.007	Pulley - Gear Box - SPA182-2-1008	2
27	3.3.04.01.005	Bushing - 1008-16	2
28	3.3.02.01.023	Gear Box - SS - 45*20 Shaft - 89mm	2
29	2.1.3.15.0009	Bracket - Gear Box - 1.3-1.8qt - 89mm	2
30	3.3.02.04.005	Coupling Drive - 1.3-1.8qt - 20mm	2
31	3.3.02.02.010	Nut - Rear Shell Bearing	2
32	2.3.6.04.029	Lock Plate - Rear Shell Bearing - 39mm	2
33	3.3.02.02.001	Rear Shell Bearing - SS - 1.3/1.8qt	2
34	3.2.04.07.001	Suction Accumulator - 25×100×0.6	1
35	3.2.04.05.001	Filter Drier - Hopper - 16×2.2×120	1
36	3.2.05.01.002	Capillary Tube - 2×0.7	1
37	3.2.03.01.001	Fan Motor - BT220-15050S2HL	1
	3.2.03.01.005	Fan Motor - UF-1751B22H (Alternative)	1
38	3.2.01.01.010.A	Auxiliary Compressor - PL35G	1
39	3.2.02.01.001	Auxiliary Condenser - Single - 0.7m ²	1
40	3.2.04.04.015	Solenoid Coil - 1068	2
41	3.2.04.04.002	Solenoid Valve Body - 1068	2
42	3.2.04.04.020	Solenoid Coil - 220V/6W	2
43	3.2.04.04.004	Solenoid Valve Body - EVU6 - 6W	2

3. Dispensing Door and Beater

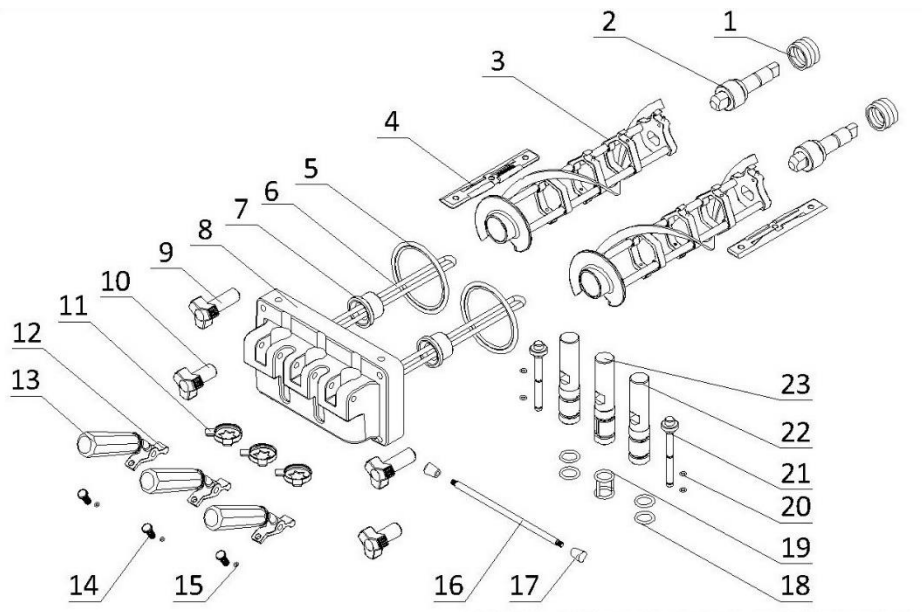

Item	Part Number	Description	Qty.
1	3.4.07.05.002	Gasket - Drive Shaft	2
2	2.1.3.25.0001	Drive Shaft - SS - 1.3-1.8qt	2
3	2.1.1.10.0017	Beater - SS - Medium - 1.8qt - V2	2
4	3.4.02.01.005	Scraper Blade - Small - V2	4
5	3.4.08.02.007	Door Gasket - SS - 1.3-1.8qt	2
6	2.1.1.11.0001	Beater Rod - SS - 1.8qt (With O-ring)	2
7	3.4.01.03.007	Beater Guide - SS - 1.3-1.8qt - V2	2
8	2.1.3.14.0003	Dispensing Door - SS - 2F - 1.8qt	1
9	3.4.05.02.010	Hand Screw - Long - Dispensing - 1.8qt	2
10	3.4.05.02.008	Hand Screw - Short - Dispensing - 1.8qt	2
11	3.4.05.03.005	Design Cap - Double Triangle - 37mm	3
12	2.1.3.26.0001	Seat - Handle - 2F - 1.3-1.8qt	3
13	3.4.05.01.001	Handle - Dispensing - SS	3
14	3.6.39.009	Adjustment Screw - Handle - 22mm	3
15	3.4.08.01.012	O-Ring - 3x1.5	3
16	2.1.3.27.0002	Retention Pin - Handle - 2F - 1.8qt	1
17	2.1.3.27.0025	Nut - Retention Pin - Handle	2
18	3.4.08.01.011	O-Ring - 19x3	4
19	3.4.08.01.019	H-Ring - 19x3x2	1
20	3.4.08.01.013	O-Ring - 5.2x1.9	4
21	2.1.3.02.0015	Prime Plug - SS - Standard	2
22	2.1.3.01.0009	Draw Valve - SS - 2F - 1.8qt - Side	2
23	2.1.3.02.0003	Draw Valve - SS - 2F - 1.8qt - Middle	1

4. Draw Switch and Front Control Panel

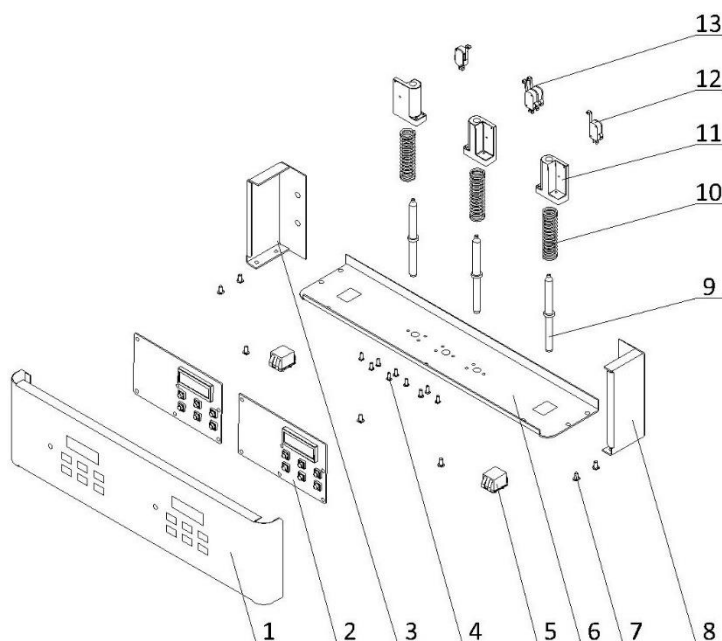

Item	Part Number	Description	Qty.
1	2.3.4.33.029	Panel - Overhead Front - 2F - 1.8qt	1
2	920.1.01.0006	Control Board - SS - V2.152 - Horizontal - V2	2
3	2.3.4.37.025	Panel - Overhead Left - 2F -1.8qt	1
4	3.6.22.028	Screw - M4×12	9
5	3.1.03.03.003	Power Switch - KCD2-2	2
6	2.3.4.39.044	Panel - Overhead Bottom - 2F - 1.8qt	1
7	3.6.22.010	Screw_ M5×10	7
8	2.3.4.38.025	Panel - Overhead Right - 2F - 1.8qt	1
9	2.1.3.50.0066	Shaft - Draw Switch - 2F - 1.8qt	3
10	3.6.03.012	Spring - Shaft - Draw Switch	3
11	3.4.07.06.008	Bracket - Micro Switch & Shaft & Spring	3
12	3.1.03.01.002	Micro Switch - KW-7-2	2
13	3.1.03.01.005	Micro Switch - KW-7-2X2	1

5. Hopper Agitator

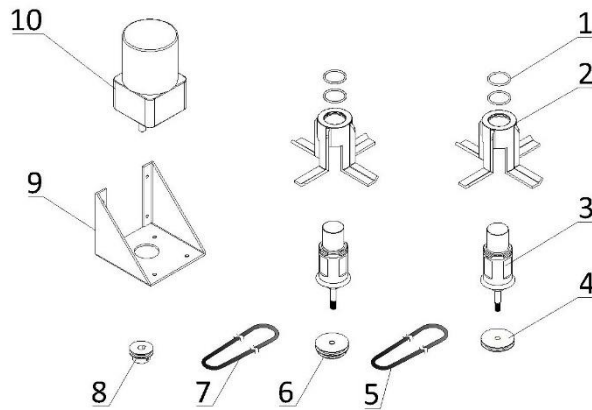

Item	Part Number	Description	Qty.
1	3.4.08.01.034	O-Ring - 31x2	4
2	2.1.1.23.0002	Blade - Hopper Agitator - Standard - V2	2
3	2.1.1.12.0003	Agitator Assembly - 124mm	2
4	2.1.4.02.015	Pulley - Hopper Agitator - Single - 53mm	1
5	2.1.4.08.003	Belt - Hopper Agitator - 600mm	1
6	2.1.4.02.016	Pulley - Hopper Agitator - Double - 53mm	1
7	2.1.4.08.023	Belt - Hopper Agitator - 265mm	1
8	3.3.04.04.006	Pulley - Hopper Agitator - Drive - 30mm	1
9	2.3.4.45.007	Bracket - Agitator Motor - 110mm	1
10	3.3.01.01.006	Motor - Agitator - 220V - YN80-25-6G	1

6. Control Box

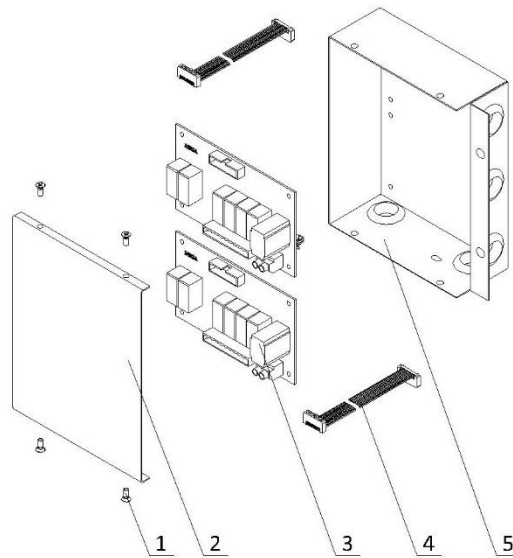

Item	Part Number	Description	Qty.
1	3.6.19.001	Screw - M4x8	4
2	2.2.4.23.0062	Cover - Control Box - 6235-C/6235-AC	1
3	2.2.1.01.0007	Power Board - SS - V2.152	2
4	3.1.04.01.003	Ribbon Cable - 20 Pin	2
5	2.2.4.23.0061	Control Box - 6235-C/6235-AC	1

7. Electrical Box

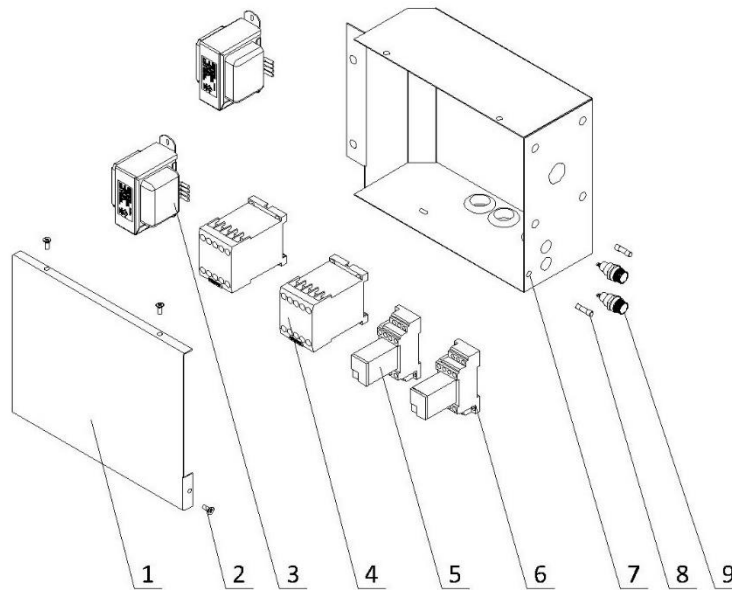

Item	Part Number	Description	Qty.
1	2.2.4.22.0012	Cover - Electrical Box 1 - 6235-C/6235-AC	1
2	3.6.19.001	Screw - M4x8	3
3	3.1.01.04.007	Transformer - 50W - 50313MW-32	2
4	3.1.01.01.010	Contactor - 220V - 3RT6017-1AN21	2
5	3.1.01.03.029	Intermediate Relay - AC220V - HH54P-L	2
6	3.1.01.03.031	Base - Relay - TP514X1-E	2
7	2.2.4.19.0007	Electrical Box 1 - 6235-C/6235-AC	1
8	3.1.02.08.002	Fuse - 0.5A	2
9	3.1.02.08.012	Seat - Fuse - 250V	2