

**1. External Parts**

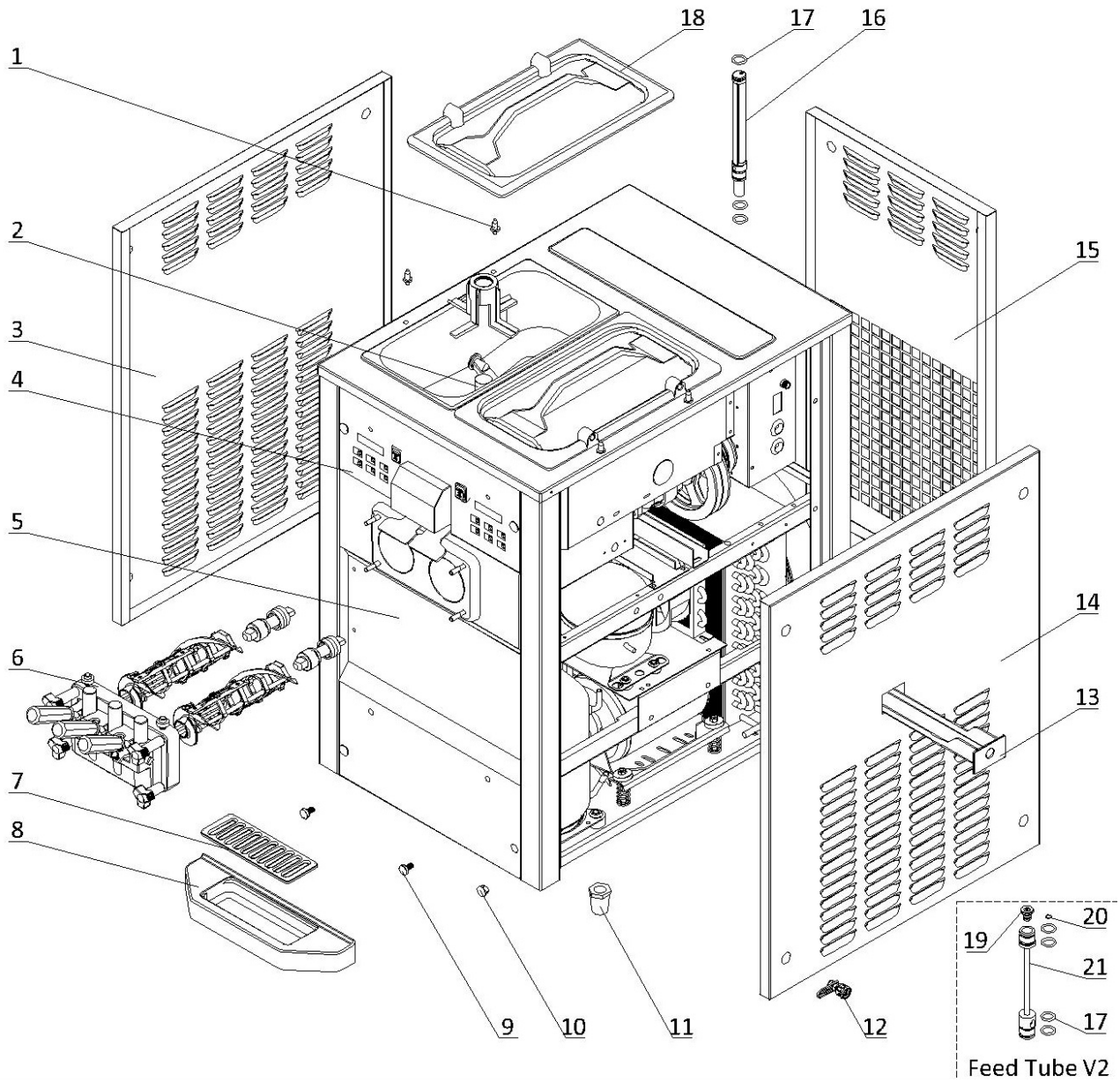

## 1. External Parts

Item	Part Number	Description	Qty.
1	3.6.39.011	Hopper Lid Holder	4
2	Page 8	Hopper Agitator	2
3	2.3.4.18.008	Panel - Left - 6235/6235A	1
4	Page 7	Draw Switch and Front Control Panel	1
5	2.3.4.17.011	Panel - Lower Front - 6235/6235A	1
6	Page 5	Dispensing Door and Beater	1
7	3.4.04.01.002-1	Splash Shield - Front Drip Tray - 37.2mm	1
8	<a href="#">3.4.04.01.002</a>	Front Drip Tray - 37.2mm	1
9	3.6.39.004	Drip Tray Mounting Bolt	2
10	3.4.07.01.001	Bolt Hole Cover	4
11	3.3.05.03.001	Leg - 45mm	4
12	8.1.07.001	Panel Lock Assembly	12
13	<a href="#">3.4.04.02.001</a>	Internal Drip Tray - 45mm	1
14	2.3.4.20.008	Panel - Right - 6235/6235A	1
15	2.3.4.13.008	Panel - Rear - 6235/6235A	1
16	<a href="#">2.1.3.39.0011</a>	Air Tube - SS - Long - V3	2
17	3.4.08.01.002	O-Ring - 18x2.2	3
18	<a href="#">3.4.03.01.004</a>	Hopper Lid - 12-15L	2
19	2.1.3.23.0001	Air Tube Cap - SS - Small (Old Version)	2
20	3.4.08.01.028	O-Ring - 6.2x1.9 (Old Version)	2
21	<a href="#">3.4.07.04.020</a>	Air Tube - SS - Long - V2 (Old Version)	2

**2. Internal Parts**

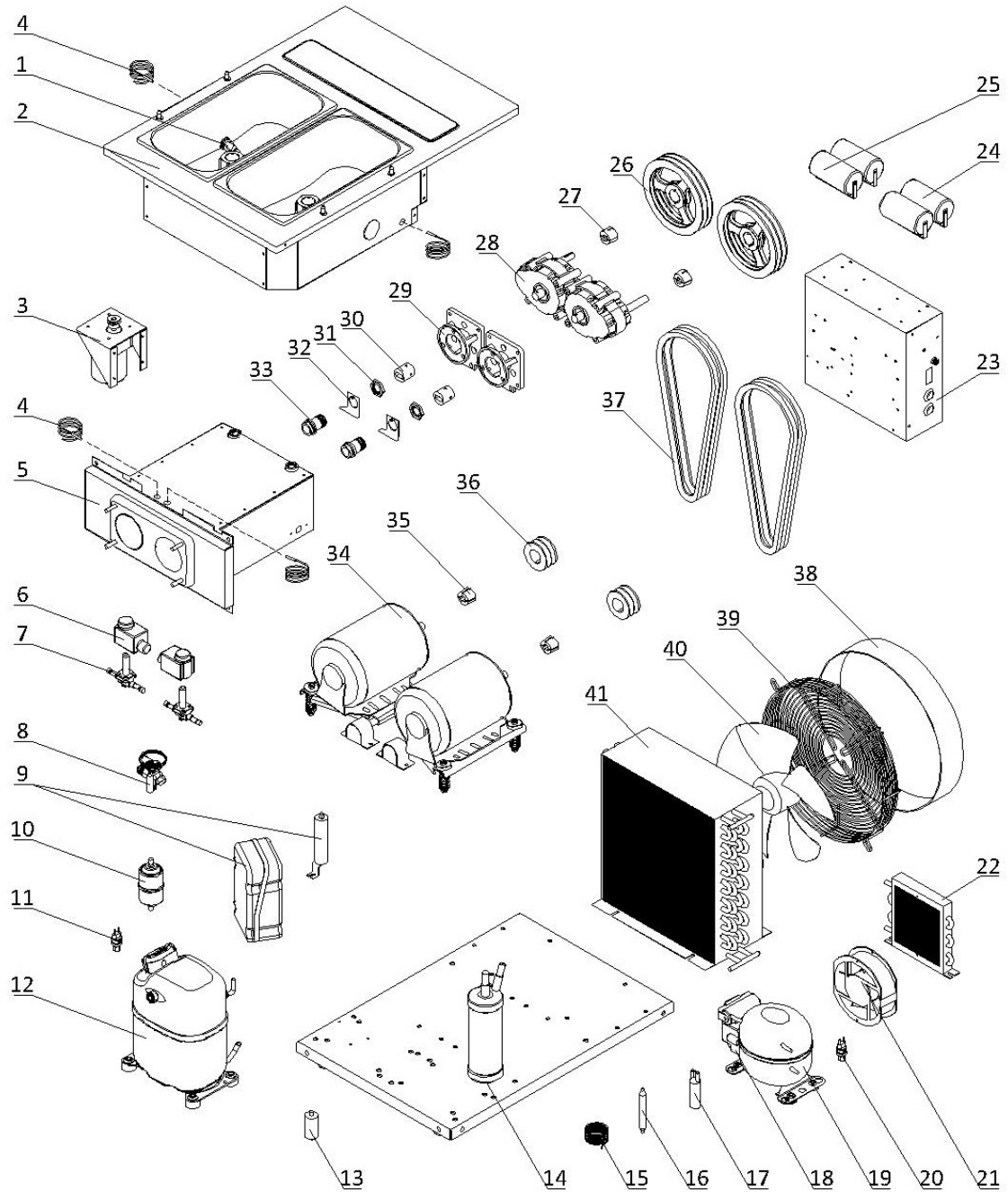

## 2. Internal Parts

Item	Part Number	Description	Qty.
1	920.1.04.0002	Mix Low Sensor Assembly	2
2	2.1.1.03.0050	Hopper Assembly - 6235	1
3	Page 8	Agitator Motor Assembly	1
4	3.1.02.13.020	Temperature Probe - PT100	4
5	2.1.1.06.0025	Cylinder Assembly - 6235/6235A/6250/6250A	1
6	3.2.04.04.015	Solenoid Coil - 1068	2
7	3.2.04.04.002	Solenoid Valve Body - 1068	2
8	3.2.04.01.012	Thermal Expansion Valve - TUB2132 (Since 192148)	1
9	3.2.01.04.004	Start Component - Compressor - CAJ2464Z	1
10	3.2.04.05.002	Filter Drier - Cylinder - DML083S	1
11	3.2.04.06.004	High Pressure Switch - 350~500psi	1
12	3.2.01.02.005.A	Primary Compressor - CAJ2464Z	1
13	3.2.03.04.001-2	Capacitor - Fan Motor - 450V - 5µF - CBB60	1
14	3.2.04.08.001	liquid Receiver - 76x280	1
15	3.2.05.01.002	Capillary Tube - 2x0.7	1
16	3.2.04.05.001	Filter Drier - Hopper - 16x2.2x120	1
17	3.2.04.07.001	Suction Accumulator - 25x100x0.6	1
18	3.2.01.01.002-1	Start Component - Compressor - EM30HHR	1
19	3.2.01.01.002.A	Auxiliary Compressor - EM30HHR	1
20	3.2.04.06.003	High Pressure Switch - 250~350psi	1
21	3.2.03.01.001	Fan Motor - BT220-15050S2HL	1
22	3.2.02.01.001	Auxiliary Condenser - Single - 0.7m <sup>2</sup>	1
23	Page 9	Electrical Box	1
24	3.1.02.22.061	Capacitor - Start - 330V - 267.5µF	2
25	3.1.02.22.009	Capacitor - Running - 370V - 25µF	2
26	3.3.04.02.007	Pulley - Gear Box - SPA182-2-1008	2
27	3.3.04.01.005	Bushing - 1008-16	2
28	3.3.02.01.023	Gear Box - SS - 45*20 Shaft - 89mm (Since 190181)	2
29	2.1.3.15.0009	Bracket - Gear Box - 1.3-1.8qt - 89mm	2
30	3.3.02.04.005	Coupling Drive - 1.3-1.8qt - 20mm	2
31	3.3.02.02.010	Nut - Rear Shell Bearing	2
32	2.3.6.04.029	Lock Plate - Rear Shell Bearing - 39mm	2
33	3.3.02.02.001	Rear Shell Bearing - SS - 1.3/1.8qt	2
34	3.3.01.05.003	Motor - 220/60/1 - 900W - K56AC63F41	2
35	3.3.04.01.006	Bushing - 1108-16	2
36	3.3.04.02.003	Pulley - Beater Motor - SPA71-2-1108	2
37	3.3.03.01.017	Belt - Motor to Beater - V-XPA1232	4
38	2.1.3.50.0002	Fan Shroud - 120mm	1
39/40	3.2.03.04.001	Fan Motor - 220/60/1 - YWF4E-350S	1
41	3.2.02.01.007	Main Condenser - Single - 10m <sup>2</sup>	1

### 3. Dispensing Door and Beater

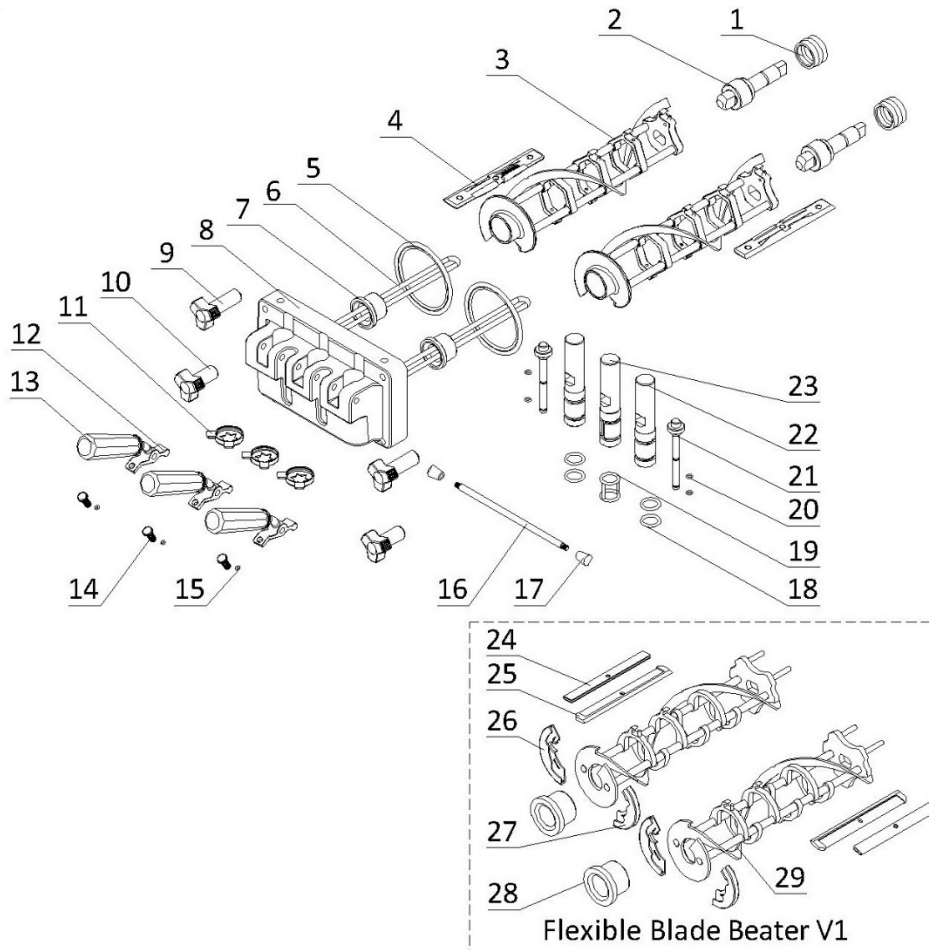

### 3. Dispensing Door and Beater

Item	Part Number	Description	Qty.
1	3.4.07.05.002	Gasket - Drive Shaft	2
2	2.1.3.25.0001	Drive Shaft - SS - 1.3-1.8qt	2
3	2.1.1.10.0017	Beater - SS - Medium - 1.8qt - V2	2
4	3.4.02.01.005	Scraper Blade - Small - V2	4
5	3.4.08.02.007	Door Gasket - SS - 1.3-1.8qt	2
6	2.1.1.11.0001	Beater Rod - SS - 1.8qt	2
7	3.4.01.03.007	Beater Guide - SS - 1.3-1.8qt - V2	2
8	2.1.3.14.0003	Dispensing Door - SS - 2F - 1.8qt	1
9	3.4.05.02.010	Hand Screw - Long - Dispensing - 1.8qt	2
10	3.4.05.02.008	Hand Screw - Short - Dispensing - 1.8qt	2
11	3.4.05.03.005	Design Cap - Double Triangle - 37mm	3
12	2.1.3.26.0001	Seat - Handle - 2F - 1.3-1.8qt	3
13	3.4.05.01.001	Handle - Dispensing - SS	3
14	3.6.39.009	Adjustment Screw - Handle - 22mm	3
15	3.4.08.01.012	O-Ring - 3x1.5	3
16	2.1.3.27.0002	Retention Pin - Handle - 2F - 1.8qt	1
17	2.1.3.27.0025	Nut - Retention Pin - Handle	2
18	3.4.08.01.011	O-Ring - 19x3	4
19	3.4.08.01.019	H-Ring - 19x3x2	1
20	3.4.08.01.013	O-Ring - 5.2x1.9	4
21	2.1.3.02.0015	Prime Plug - SS - Standard	2
22	2.1.3.01.0009	Draw Valve - SS - 2F - 1.8qt - Side	2
23	2.1.3.02.0003	Draw Valve - SS - 2F - 1.8qt - Middle	1
24	2.3.4.04.001	Clip - Scraper Blade - 1.8qt (Old Version)	4
25	3.4.02.01.002	Plastic - Scraper Blade - 1.8qt (Old Version)	4
26	3.4.01.01.002	Shoe - Left Small - 1.3-1.8qt (Old Version)	2
27	3.4.01.02.002	Shoe - Right Small - 1.3-1.8qt (Old Version)	2
28	3.4.01.03.001	Beater Guide - SS - 1.3-1.8qt (Old Version)	2
29	2.1.1.10.0002	Beater - SS - Medium - 1.8qt (Old Version)	2

#### 4. Draw Switch and Front Control Panel

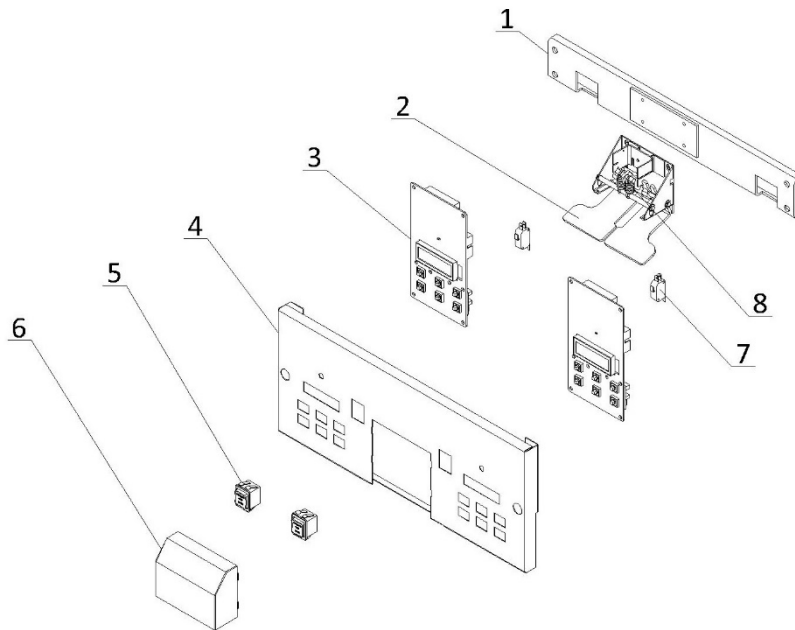

Item	Part Number	Description	Qty.
1	2.2.4.24.0003	Bracket - Draw Switch Assembly - 2F/3F -1.8qt	1
2	2.1.1.19.0004	Draw Switch Assembly - 2F	1
3	<a href="#">2.2.1.01.0004</a>	Control Board - SS - V2.152 - Standard	2
4	2.3.4.08.002	Panel - Draw Switch - 2F - 1.8qt	1
5	<a href="#">3.1.03.03.003</a>	Power Switch - KCD2-2	2
6	<a href="#">3.4.07.07.004</a>	Switch Cover - Standard	1
7	<a href="#">3.1.03.01.004</a>	Micro Switch - KW-7-9	2
8	3.6.02.002	Spring - Draw Switch Assembly	2

## 5. Hopper Agitator

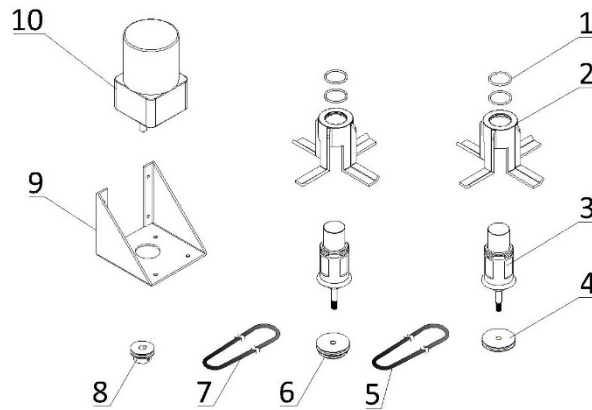

Item	Part Number	Description	Qty.
1	3.4.08.01.034	O-Ring - 31x2	4
2	2.1.1.23.0002	Blade - Hopper Agitator - Standard - V2	2
3	2.1.1.12.0003	Agitator Assembly - 124mm	2
4	2.1.4.02.015	Pulley - Hopper Agitator - Single - 53mm	1
5	2.1.4.08.003	Belt - Hopper Agitator - 600mm	1
6	2.1.4.02.016	Pulley - Hopper Agitator - Double - 53mm	1
7	2.1.4.08.023	Belt - Hopper Agitator - 265mm	1
8	3.3.04.04.006	Pulley - Hopper Agitator - Drive - 30mm	1
9	2.3.4.45.007	Bracket - Agitator Motor - 110mm	1
10	3.3.01.01.006	Motor - Agitator - 220V - YN80-25-6G	1

## 6. Electrical Box

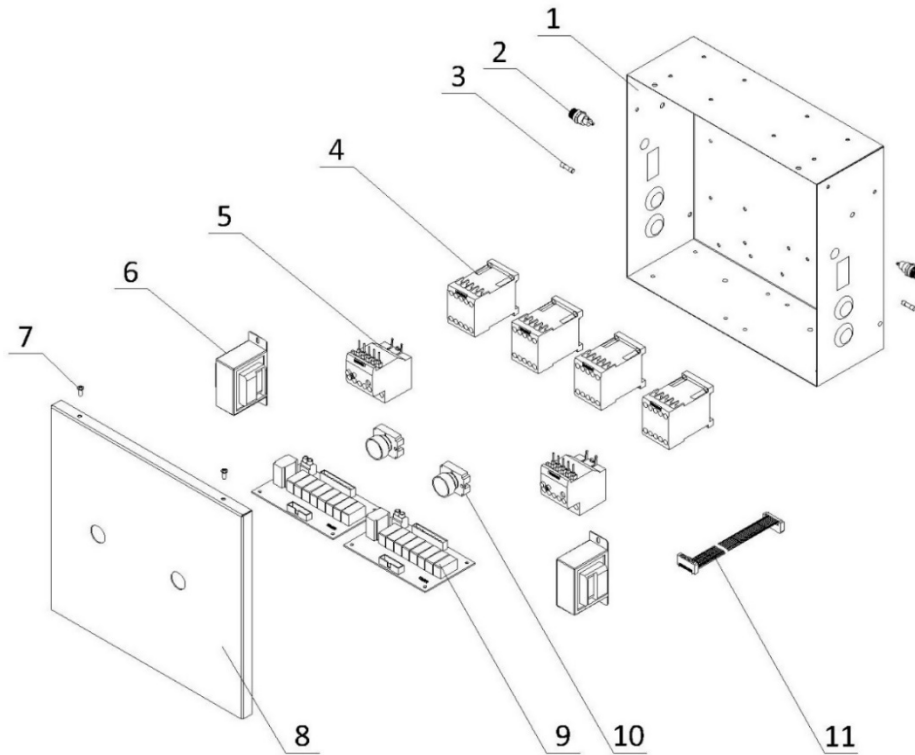

Item	Part Number	Description	Qty.
1	2.2.4.17.0002	Electrical Box - 6235/6235A	1
2	3.1.02.08.012	Seat - Fuse - 250V	2
3	3.1.02.08.002	Fuse - 0.5A	2
4	3.1.01.01.010	Contactor - 220V - 3RT6017-1AN21	4
5	3.1.01.02.011	Thermal Overload Relay - 3RU6116-1GB0	2
6	3.1.01.04.007	Transformer - 50W - 50313MW232	2
7	3.6.19.001	Screw - M4x8	2
8	2.2.4.20.0002	Cover - Electrical Box - 6235/6235A	1
9	2.2.1.01.0007	Power Board - SS - V2.152	1
10	3.1.03.04.002	Reset Button - Thermal Overload	2
11	3.1.04.01.003	Ribbon Cable - 20 Pin	1