

1. External Parts

Item	Part Number	Description	Qty.
1	3.4.03.01.004	Hopper Lid - 12-15L	1
2	Page 7	Hopper Agitator	1
3	3.6.39.011	Hopper Lid Holder	2
4	2.3.4.18.027	Panel Left - 6236-C/6236-AC	1
5	Page 6	Draw Switch and Front Control Panel	1
6	2.3.4.16.019	Panel Lower Front - 6236-C/6236-AC	1
7	Page 5	Dispensing Door and Beater	1
8	3.4.04.01.002	Front Drip Tray - 37.2mm	1
9	3.6.39.004	Drip Tray Mounting Bolt	2
10	3.3.05.03.005	Leg - 68mm	4
11	3.6.11.042	Panel Screw - M8x20	12
12	3.4.07.01.001	Bolt Hole Cover	12
13	3.4.04.02.003	Internal Drip Tray - 25mm	1
14	2.3.4.20.027	Panel Right - 6236-C/6236-AC	1
15	2.3.4.13.004	Panel Rear - 6236-C/6236-AC	1
16	2.1.3.39.0011	Air Tube - SS - Long - V3	1
17	3.4.08.01.002	O-Ring - 18x2.2	3
18	2.3.4.34.042	Air Chute - 6236-C/6236-AC (Optional)	1
19	2.3.4.18.032	Panel - Left - Air Chute - 6236-AC/6236-AC (Optional)	1

2. Internal Parts

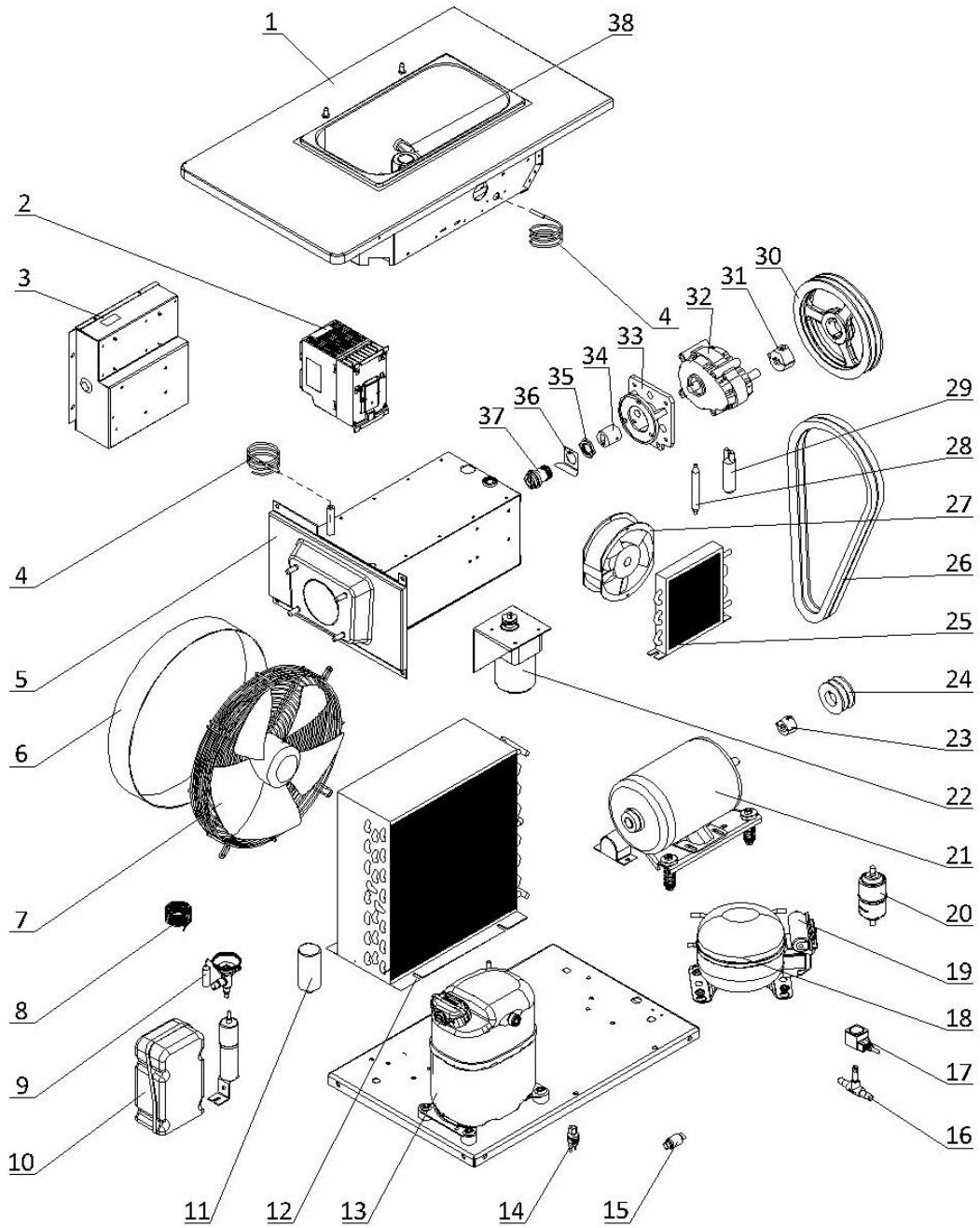

2. Internal Parts

Item	Part Number	Description	Qty.
1	2.1.1.03.0069	Hopper Assembly - 6236-C	1
2	3.1.01.08.006	Inverter - 0.75kW - EFC3610-0K75-1P2-MDA	1
3	Page 8	Electrical Box	1
4	3.1.02.13.020	Temperature Probe - PT100	2
5	2.1.1.06.0038	Cylinder Assembly - 6236-C/6236-AC	1
6	2.1.3.50.0002	Fan Shroud - 120mm	1
7	3.2.03.04.001	Fan Motor - 220/60/1 - YWF4E-350S	1
8	3.2.05.01.002	Capillary Tube - 2x0.7	1
9	3.2.04.01.012	Thermal Expansion Valve - TUB2132	1
10	3.2.01.04.004	Start Component - Compressor - CAJ2464Z	1
	3.2.01.04.024	Start Component - Compressor - CAJ4519Z (Alternative)	1
11	3.2.03.04.001-2	Capacitor - Fan Motor - 450V - 5μF - CBB60	1
12	3.2.02.01.005	Main Condenser - Single - 8m ² - 410x410x150	1
13	3.2.01.02.005.A	Primary Compressor - CAJ2464Z	1
	3.2.01.02.042.A	Primary Compressor - CAJ4519Z (Alternative)	1
14	3.2.04.06.004	High Pressure Switch - 350~500psi	1
15	3.2.04.05.010	Copper Strainer Filter - φ12	1
16	3.2.04.04.004	Solenoid Valve Body - EVU6 - 6W	1
17	3.2.04.04.020	Solenoid Coil - 230V - 6W	1
18	3.2.01.01.010.A	Auxiliary Compressor - PL35G	1
19	3.2.01.01.010-1	Start Component - Compressor - PL35G	1
20	3.2.04.05.002	Filter Drier - Cylinder - DML083S	1
21	3.3.01.04.005	Motor - 220/60/3 - 750W - P56AH60F41	1
22	Page 7	Agitator Motor Assembly	1
23	3.3.04.01.005	Bushing - 1008-16	1
24	3.3.04.02.001	Pulley - Beater Motor - SPA63-2-1008	1
25	3.2.02.01.001	Auxiliary Condenser - Single - 0.7m ²	1
26	3.3.03.01.016	Belt - Motor to Beater - V-XPA1180	2
27	3.2.03.01.001	Fan Motor - BT220-15050S2HL	1
	3.2.03.01.005	Fan Motor - UF-1751B22H (Alternative)	1
28	3.2.04.05.001	Filter Drier - Hopper - 16x2.2x120	1
29	3.2.04.07.001	Suction Accumulator - 25x100x0.6	1
30	3.3.04.02.008	Pulley - Gear Box - SPA212-2-1210	1
31	3.3.04.01.007	Bushing - 1210-16	1
32	3.3.02.01.023	Gear Box - SS - 45*20 Shaft - 89mm	1
33	2.1.3.15.0004	Bracket - Gear Box - 3.4-7.3qt - 89mm	1
34	3.3.02.04.006	Coupling Drive - 3.4qt-4.0qt-7.3qt - 20mm	1
35	3.3.02.02.010	Nut - Rear Shell Bearing	1
36	2.3.6.04.004	Lock Plate - Rear Shell Bearing - 42mm	1
37	3.3.02.02.002	Rear Shell Bearing - SS (3.4qt) + FB	1
38	920.1.04.0002	Mix Low Sensor Assembly	1

3. Dispensing Door and Beater

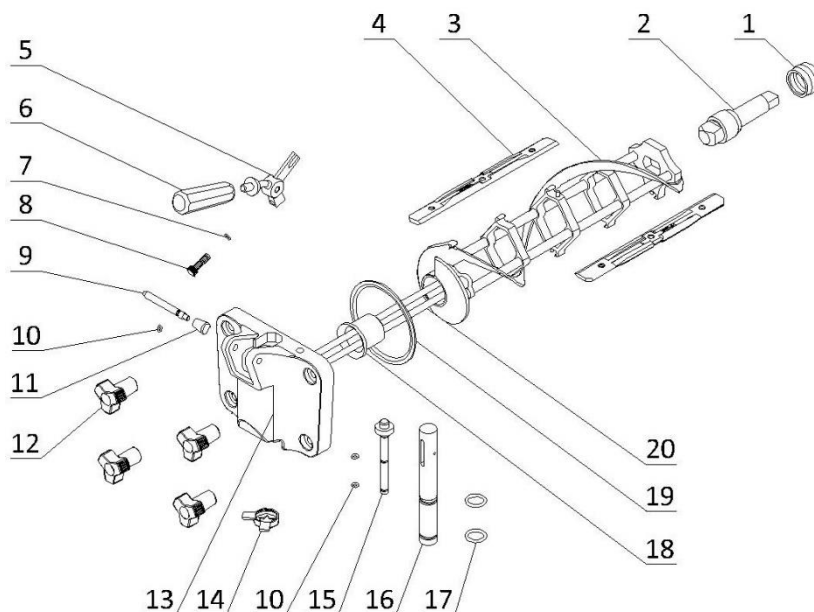

Item	Part Number	Description	Qty.
1	3.4.07.05.002	Gasket - Drive Shaft	1
2	2.1.3.25.0002	Drive Shaft - SS - 3.4qt	1
3	2.1.1.10.0018	Beater - SS - Large - 3.4qt - V2	1
4	3.4.02.01.007	Scraper Blade - Medium - V2	2
5	2.1.3.26.0005	Seat - Handle - 1F - 3.4qt	1
6	3.4.05.01.001	Handle - Dispensing - SS	1
7	3.4.08.01.012	O-Ring - 3x1.5	1
8	3.6.39.008	Adjustment Screw - Handle - 34mm	1
9	2.1.3.27.0004	Retention Pin - Handle - 1F - 3.4qt	1
10	3.4.08.01.013	O-Ring - 5.2x1.9	3
11	2.1.3.27.0025	Nut - Retention Pin - Handle	1
12	3.4.05.02.007	Hand Screw - Medium - Dispensing	4
13	2.1.3.14.0004	Dispensing Door - SS - 1F - 3.4qt	1
14	3.4.05.03.004	Design Cap - Double Triangle - 31mm	1
15	2.1.3.02.0015	Prime Plug - SS - Standard	1
16	2.1.3.01.0012	Draw Valve - SS - 1F - 6236/6236A	1
17	3.4.08.01.006	O-Ring - 16.8x2.4	2
18	3.4.01.03.008	Beater Guide - SS - 3.4qt - V2	1
19	3.4.08.02.008	Door Gasket - SS - 3.4qt	1
20	2.1.1.11.0002	Beater Rod - SS - Large - 3.4qt (With O-Ring)	1

4. Draw Switch and Front Control Panel

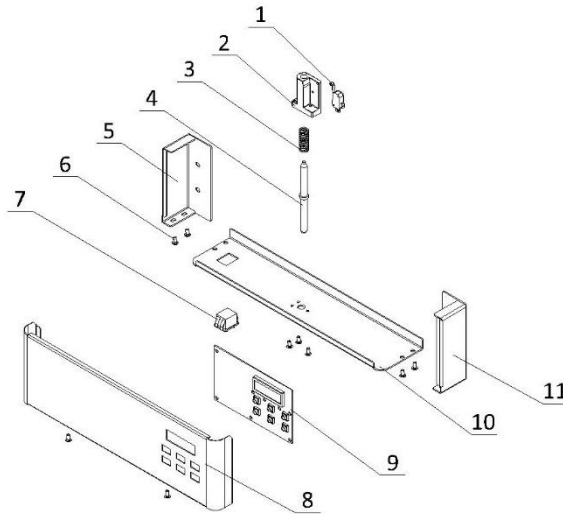

Item	Part Number	Description	Qty.
1	3.1.03.01.002	Micro Switch - KW-7-2	1
2	3.4.07.06.008	Bracket - Micro Switch & Shaft & Spring	1
3	3.6.03.012	Spring - Shaft - Draw Switch	1
4	2.1.3.50.0080	Shaft - Draw Switch - 6236-C/6236-AC	1
5	2.3.4.37.003	Panel - Overhead Left - 6228-C/6228-AC/6236-C/6236-AC	1
6	3.6.22.010	Screw - M5x10	9
7	3.1.03.03.003	Power Switch - KCD2-2	1
8	2.3.4.33.010	Panel - Overhead Front - 6236-C/6236-AC	1
9	920.1.01.0006	Control Board - SS - V2.152 - Horizontal - V2	1
10	2.3.4.39.059	Panel - Overhead Bottom - 6236-C/6236-AC	1
11	2.3.4.38.003	Panel - Overhead Right - 6228-C/6228-AC/6236-C/6236-AC	1

5. Hopper Agitator

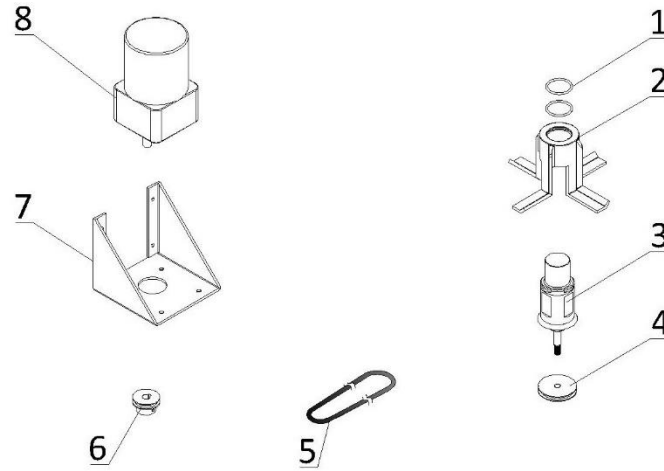

Item	Part Number	Description	Qty.
1	3.4.08.01.034	O-Ring - 31x2	2
2	2.1.1.23.0002	Blade - Hopper Agitator - Standard - V2	1
3	2.1.1.12.0001	Agitator Assembly - 129mm	1
4	2.1.4.02.017	Pulley - Hopper Agitator - Single - 47.6mm	1
5	2.1.4.08.041	Belt - Hopper Agitator - 400mm	1
6	3.3.04.04.006	Pulley - Hopper Agitator - Drive - 30mm	1
7	2.3.4.45.007	Bracket - Agitator Motor - 110mm	1
8	3.3.01.01.006	Motor - Agitator - 220V - YN80-25-6G	1

6. Electrical Box

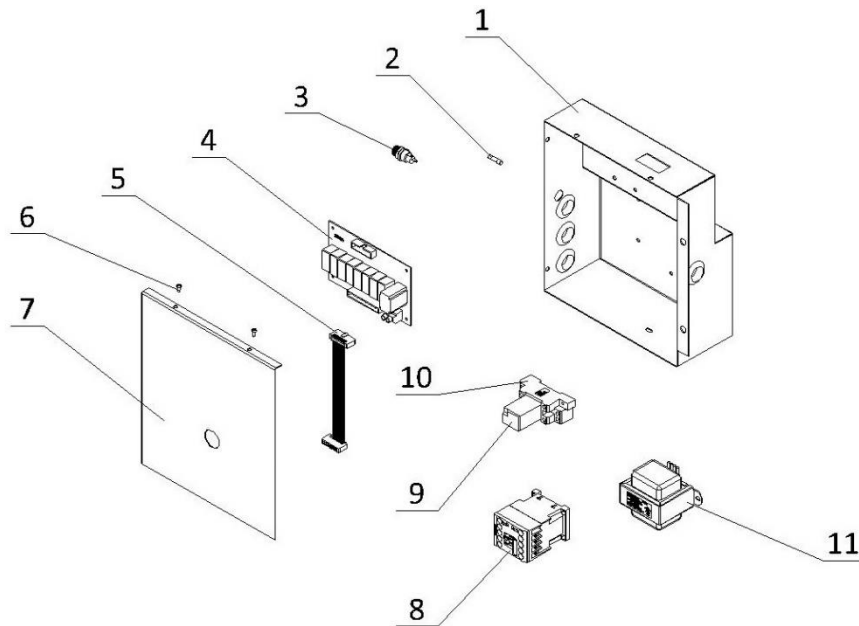

Ite	Part Number	Description	Qty.
1	2.3.1.15.004	Electrical Box - 6236	1
2	3.1.02.08.002	Fuse - 0.5A	1
3	3.1.02.08.012	Seat - Fuse - 250V	1
4	2.2.1.01.0007	Power Board - SS - V2.152	1
5	3.1.04.01.003	Ribbon Cable - 20 Pin	1
6	3.6.06.072	Screw - M4x10	2
7	2.3.1.18.006	Cover - Electrical Box - 6236	1
8	3.1.01.01.010	Contactor - 220V - 3RT6017-1AN21	1
9	3.1.01.03.029	Intermediate Relay - AC220V - HH54P-L	1
10	3.1.01.03.031	Base - Relay - TP514X1-E	1
11	3.1.01.04.007	Transformer - 50W - 50313MW-32	1