

1. External Parts

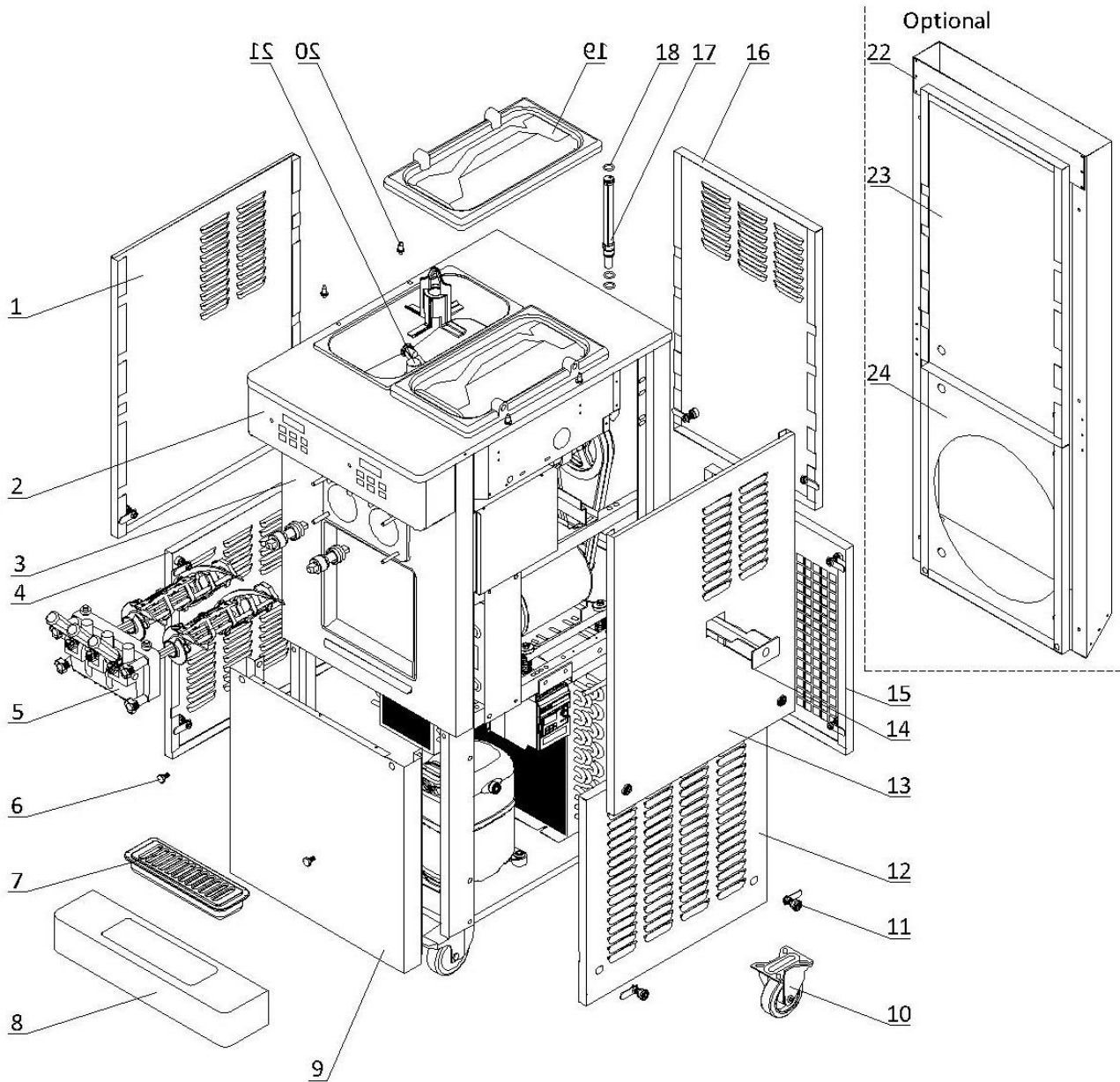

1. External Parts

| Item | Part Number | Description | Qty. |
|------|-------------------------------|--|------|
| 1 | 2.3.4.29.007 | Panel - Upper Left - 6250-C/6250-AC | 1 |
| 2 | Page 6 | Draw Switch and Front Control Panel | 1 |
| 3 | 2.3.4.26.038 | Panel - Upper Front - 6250-C/6250-AC | 1 |
| 4 | 2.3.4.32.016 | Panel - Lower Left - 6250-C/6250-AC | 1 |
| 5 | Page 5 | Dispensing Door and Beater | 1 |
| 6 | 3.6.39.004 | Drip Tray Mounting Bolt | 2 |
| 7 | 3.4.04.01.006 | Front Drip Tray - 30mm | 1 |
| 8 | 2.3.4.45.353 | Support - Front Drip Tray - V2 | 1 |
| 9 | 2.3.4.27.032 | Panel - Lower Front - 6250-C/6250-AC | 1 |
| 10 | 3.3.05.02.001 | Caster Swivel - 100X34 | 4 |
| 11 | 8.1.07.001 | Panel Lock Assembly | 18 |
| 12 | 2.3.4.32.004 | Panel - Lower Right - 6250-C/6250-AC | 1 |
| 13 | 2.3.4.31.010 | Panel - Upper Right - 6250-C/6250-AC | 1 |
| 14 | 3.4.04.02.001 | Internal Drip Tray - 45mm | 1 |
| 15 | 2.3.4.25.032 | Panel - Lower Rear - 6250-C/6250-AC | 1 |
| 16 | 2.3.4.24.025 | Panel - Upper Rear - 6250-C/6250-AC | 1 |
| 17 | 2.1.3.39.0011 | Air Tube - SS - Long - V3 | 2 |
| 18 | 3.4.08.01.002 | O-Ring - 18x2.2 | 6 |
| 19 | 3.4.03.01.004 | Hopper Lid - 12-15L | 2 |
| 20 | 3.6.39.011 | Hopper Lid Holder | 4 |
| 21 | Page 7 | Hopper Agitator | 2 |
| 22 | 2.3.4.34.044 | Air Chute - 6250-C/6250-AC (Optional) | 1 |
| 23 | 2.3.4.24.026 | Panel - Upper Rear - Air Chute - 6250-C/6250-AC (Optional) | 1 |
| 24 | 2.3.4.25.034 | Panel - Lower Rear - Air Chute - 6250-C/6250-AC (Optional) | 1 |

2. Internal Parts

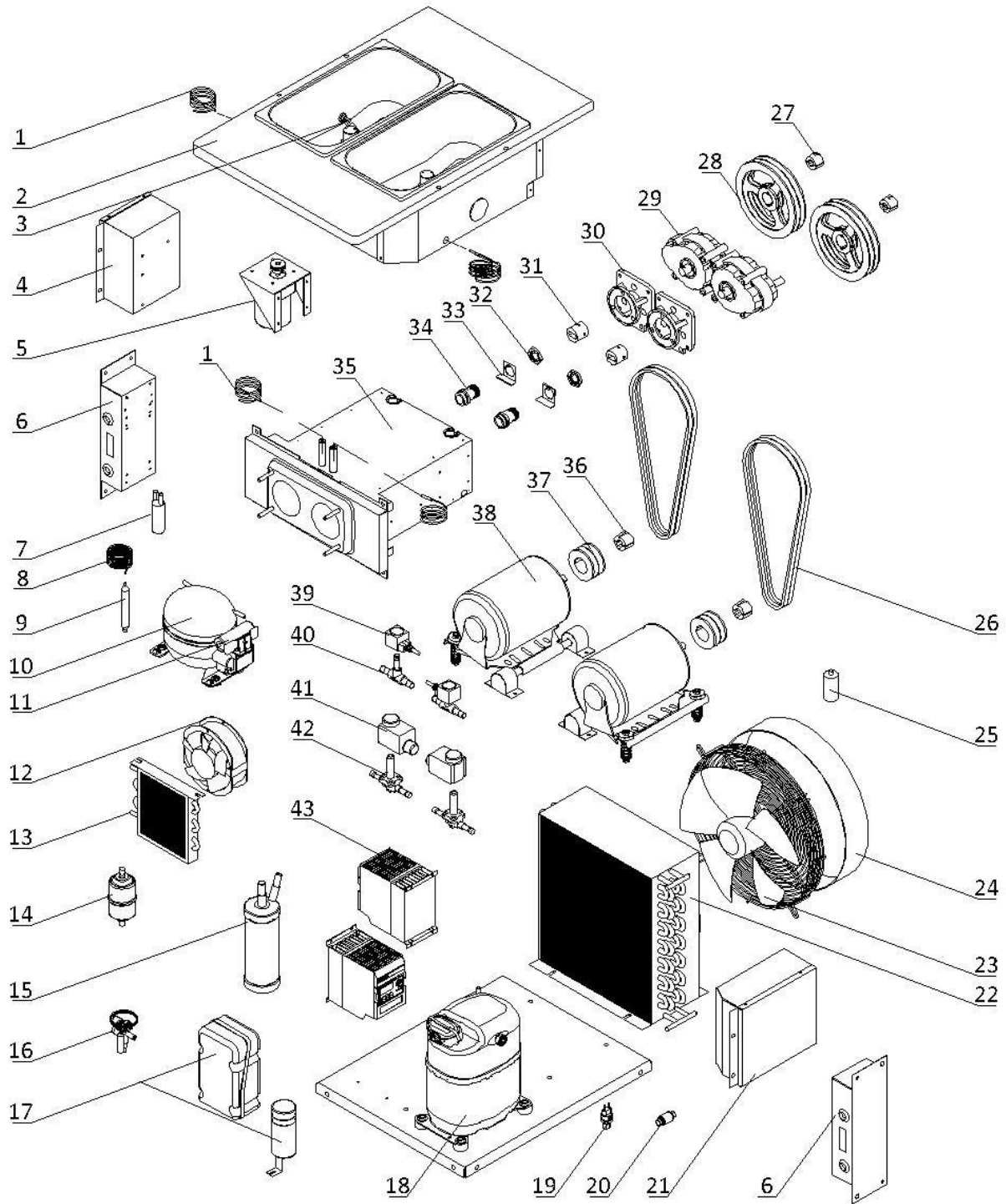

| Item | Part Number | Description | Qty. |
|------|-------------------------------|---------------------------------|------|
| 1 | 3.1.02.13.020 | Temperature Probe - PT100 | 4 |
| 2 | 2.1.1.03.0054 | Hopper Assembly - 6235-C/6250-C | 1 |
| 3 | 920.1.04.0002 | Mix Low Sensor Assembly | 2 |
| 4 | Page 9 | Electrical Box - Left | 1 |
| 5 | Page 7 | Agitator Motor Assembly | 2 |

| | | | |
|----|-----------------|--|---|
| 6 | Page 8 | Control Box | 2 |
| 7 | 3.2.04.07.001 | Suction Accumulator - 25×100×0.6 | 1 |
| 8 | 3.2.05.01.003 | Capillary Tube - 2.2×0.9 | 1 |
| 9 | 3.2.04.05.001 | Filter Drier - Hopper - 16×2.2×120 | 1 |
| 10 | 3.2.01.01.005.A | Auxiliary Compressor - TL3G | 1 |
| 11 | 3.2.01.01.005-1 | Start Component - Compressor - TL3G | 1 |
| 12 | 3.2.03.01.001 | Fan Motor - BT220-15050S2HL | 1 |
| | 3.2.03.01.005 | Fan Motor - UF-1751B22H (Alternative) | 1 |
| 13 | 3.2.02.01.001 | Auxiliary Condenser - Single - 0.7m ² | 1 |
| 14 | 3.2.04.05.002 | Filter Drier - Cylinder - DML083S | 1 |
| 15 | 3.2.04.08.001 | liquid Receiver - 76×280 | 1 |
| 16 | 3.2.04.01.012 | Thermal Expansion Valve - TUB2132 | 1 |
| | 3.2.04.01.001 | Expansion Valve - T2 (Adapters included) (Alternative) | 1 |
| 17 | 3.2.01.04.004 | Start Component - Compressor - CAJ2464Z | 1 |
| | 3.2.01.04.024 | Start Component - Compressor - CAJ4519Z (Alternative) | 1 |
| 18 | 3.2.01.02.005.A | Primary Compressor - CAJ2464Z | 1 |
| | 3.2.01.02.042.A | Primary Compressor - CAJ4519Z (Alternative) | 1 |
| 19 | 3.2.04.06.004 | High Pressure Switch - 350~500psi | 1 |
| 20 | 3.2.04.05.010 | Copper Strainer Filter - φ12 | 1 |
| 21 | Page 9 | Electrical Box - Right | 1 |
| 22 | 3.2.02.01.007 | Main Condenser - Single - 10m ² | 1 |
| 23 | 3.2.03.04.001 | Fan Motor - 220/60/1 - YWF4E-350S | 1 |
| 24 | 2.1.3.50.0002 | Fan Shroud - 120mm | 1 |
| 25 | 3.2.03.04.001-2 | Capacitor - Fan Motor - 450V - 5μF - CBB60 | 1 |
| 26 | 3.3.03.01.013 | Belt - Motor to Beater - XPA1060 | 4 |
| 27 | 3.3.04.01.005 | Bushing - 1008-16 | 2 |
| 28 | 3.3.04.02.007 | Pulley - Gear Box - SPA182-2-1008 | 2 |
| 29 | 3.3.02.01.023 | Gear Box - SS - 45*20 Shaft - 89mm | 2 |
| | 3.3.02.01.028 | Gear Box - SS - 45*20 Shaft - 89mm (Alternative) | 2 |
| 30 | 2.1.3.15.0009 | Bracket - Gear Box - 1.3-1.8qt - 89mm | 2 |
| 31 | 3.3.02.04.008 | Coupling Drive - 1.3-1.8qt - 20mm - V2 | 2 |
| 32 | 3.3.02.02.010 | Nut - Rear Shell Bearing | 2 |
| 33 | 2.3.6.04.029 | Lock Plate - Rear Shell Bearing - 39mm | 2 |
| 34 | 3.3.02.02.001 | Rear Shell Bearing - SS - 1.3/1.8qt | 2 |
| 35 | 2.1.1.06.0104 | Cylinder Assembly - 2F - 1.8qt | 1 |
| | 2.1.1.06.0093 | W.E. Cylinder Assembly - 2F - 1.8qt (Alternative) | 1 |
| 36 | 3.3.04.01.006 | Bushing - 1108-16 | 2 |
| 37 | 3.3.04.02.003 | Pulley - Beater Motor - SPA71-2-1108 | 2 |
| 38 | 3.3.01.04.005 | Motor - 750W/3Ph - P56AH60F41 | 2 |
| 39 | 3.2.04.04.020 | Solenoid Coil - 220V/6W | 2 |
| 40 | 3.2.04.04.004 | Solenoid Valve Body - EVU6 - 6W | 2 |
| 41 | 3.2.04.04.015 | Solenoid Coil - 1068 | 2 |
| 42 | 3.2.04.04.002 | Solenoid Valve Body - 1068 | 2 |
| 43 | 3.1.01.08.006 | Inverter - 0.75kW - EFC3610-0K75-1P2-MDA | 2 |

2. Dispensing Door and Beater

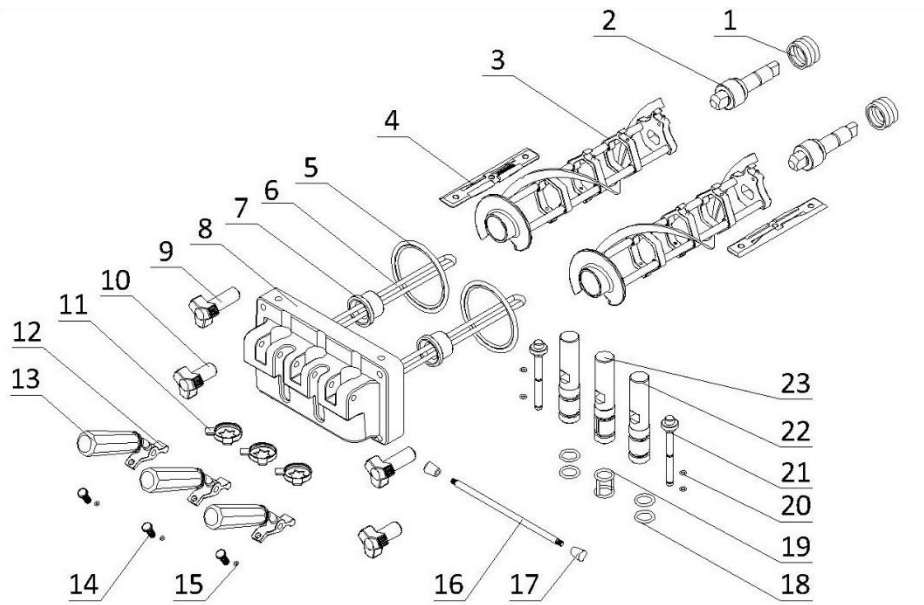

| Item | Part Number | Description | Qty. |
|------|-------------------------------|--|------|
| 1 | 3.4.07.05.002 | Gasket - Drive Shaft | 2 |
| 2 | 2.1.3.25.0001 | Drive Shaft - SS - 1.3-1.8qt | 2 |
| 3 | 2.1.1.10.0017 | Beater - SS - Medium - 1.8qt - V2 | 2 |
| 4 | 3.4.02.01.005 | Scraper Blade - Small - V2 | 4 |
| 5 | 3.4.08.02.007 | Door Gasket - SS - 1.3-1.8qt | 2 |
| 6 | 2.1.1.11.0005 | Beater Rod - SS - 1.8qt - V2 (With O-Ring) | 2 |
| 7 | 3.4.01.03.007 | Beater Guide - SS - 1.3-1.8qt - V2 | 2 |
| 8 | 2.1.3.14.0024 | Dispensing Door - SS - 2F - 1.8qt - V2 | 1 |
| 9 | 3.4.05.02.010 | Hand Screw - Long - Dispensing - 1.8qt | 2 |
| 10 | 3.4.05.02.008 | Hand Screw - Short - Dispensing - 1.8qt | 2 |
| 11 | 3.4.05.03.005 | Design Cap - Double Triangle - 37mm | 3 |
| 12 | 2.1.3.26.0001 | Seat - Handle - 2F - 1.3-1.8qt | 3 |
| 13 | 3.4.05.01.001 | Handle - Dispensing - SS | 3 |
| 14 | 3.6.39.009 | Adjustment Screw - Handle - 22mm | 3 |
| 15 | 3.4.08.01.012 | O-Ring - 3x1.5 | 3 |
| 16 | 2.1.3.27.0002 | Retention Pin - Handle - 2F - 1.8qt | 1 |
| 17 | 2.1.3.27.0025 | Nut - Retention Pin - Handle | 2 |
| 18 | 3.4.08.01.011 | O-Ring - 19x3 | 4 |
| 19 | 3.4.08.01.019 | H-Ring - 19x3x2 | 1 |
| 20 | 3.4.08.01.013 | O-Ring - 5.2x1.9 | 4 |
| 21 | 2.1.3.02.0015 | Prime Plug - SS - Standard | 2 |
| 22 | 2.1.3.01.0009 | Draw Valve - SS - 2F - 1.8qt - Side | 2 |
| 23 | 2.1.3.02.0003 | Draw Valve - SS - 2F - 1.8qt - Middle | 1 |

3. Draw Switch and Front Control Panel

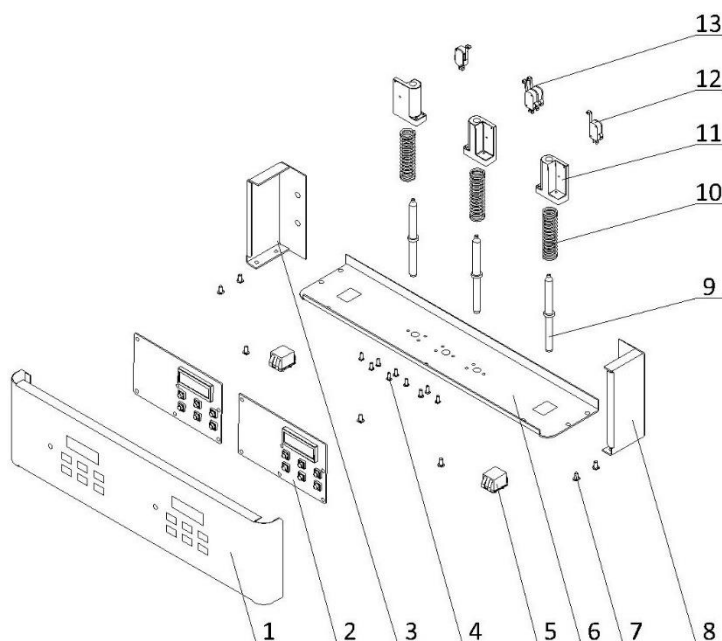

| Item | Part Number | Description | Qty. |
|------|-------------------------------|---|------|
| 1 | 2.3.4.36.024 | Panel - Overhead Front - 2F - 1.8qt | 1 |
| | 3.1.06.05.019 | Sticker - 2F - 1.8qt | 1 |
| 2 | 920.1.01.0006 | Control Board - SS - V2.152 - Horizontal - V2 | 2 |
| 3 | 2.3.4.37.044 | Panel - Overhead Left - 6250-C/6250A-C | 1 |
| 4 | 3.6.22.028 | Screw - M4×12 | 9 |
| 5 | 3.1.03.03.003 | Power Switch - KCD2-2 | 2 |
| 6 | 2.3.4.39.042 | Panel - Overhead Bottom - 2F - 1.8qt | 1 |
| 7 | 3.6.22.010 | Screw_ M5×10 | 7 |
| 8 | 2.3.4.38.042 | Panel - Overhead Right - 6250-C/6250A-C | 1 |
| 9 | 2.1.3.50.0066 | Shaft - Draw Switch - 2F - 1.8qt | 3 |
| 10 | 3.6.03.012 | Spring - Shaft - Draw Switch | 3 |
| 11 | 3.4.07.06.008 | Bracket - Micro Switch & Shaft & Spring | 3 |
| 12 | 3.1.03.01.002 | Micro Switch - KW-7-2 | 2 |
| 13 | 3.1.03.01.005 | Micro Switch - KW-7-2X2 | 1 |

4. Hopper Agitator

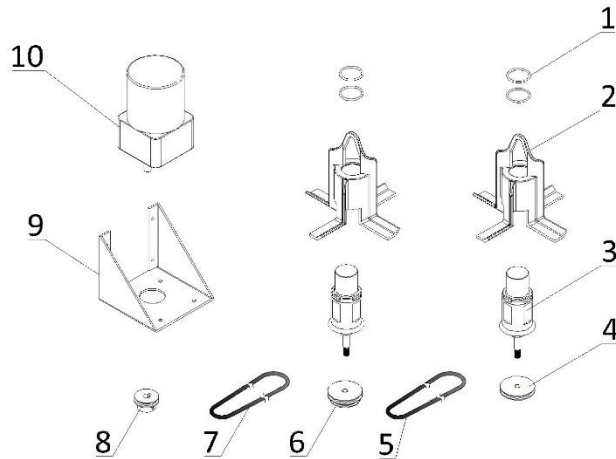

| Item | Part Number | Description | Qty. |
|------|-------------------------------|--|------|
| 1 | 3.4.08.01.034 | O-Ring - 31x2 | 4 |
| 2 | 2.1.1.23.0002 | Blade - Hopper Agitator - Standard - V2 | 2 |
| 3 | 2.1.1.12.0003 | Agitator Assembly - 124mm | 2 |
| 4 | 2.1.4.02.015 | Pulley - Hopper Agitator - Single - 53mm | 1 |
| 5 | 2.1.4.08.003 | Belt - Hopper Agitator - 610mm | 1 |
| 6 | 2.1.4.02.016 | Pulley - Hopper Agitator - Double - 53mm | 1 |
| 7 | 2.1.4.08.023 | Belt - Hopper Agitator - 260mm | 1 |
| 8 | 3.3.04.04.006 | Pulley - Hopper Agitator - Drive - 30mm | 1 |
| 9 | 2.3.4.45.007 | Bracket - Agitator Motor - 110mm | 1 |
| 10 | 3.3.01.01.006 | Motor - Agitator - 220V - YN80-25-6G | 1 |

5. Control Box

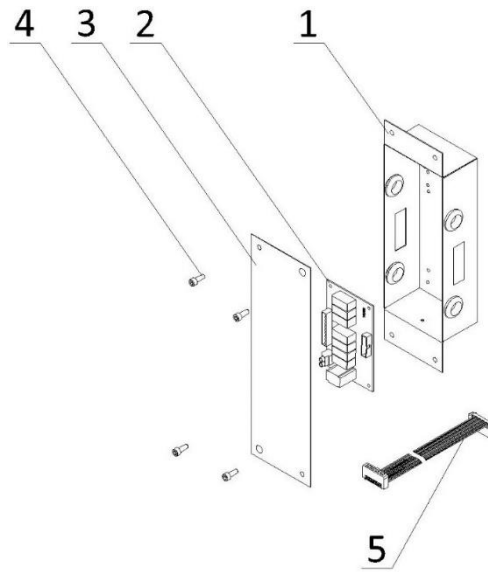

| Item | Part Number | Description | Qty. |
|------|-------------------------------|--------------------------------------|------|
| 1 | 2.2.4.23.0001 | Control Box - 6250-C/6250-AC | 2 |
| 2 | 2.2.1.01.0007 | Power Board - SS - V2.152 | 2 |
| 3 | 2.2.4.23.0002 | Cover - Control Box - 6250-C/6250-AC | 2 |
| 4 | 3.6.11.021 | Screw - M6×16 | 8 |
| 5 | 3.1.04.01.003 | Ribbon Cable - 20 Pin | 2 |

6. Electrical Box

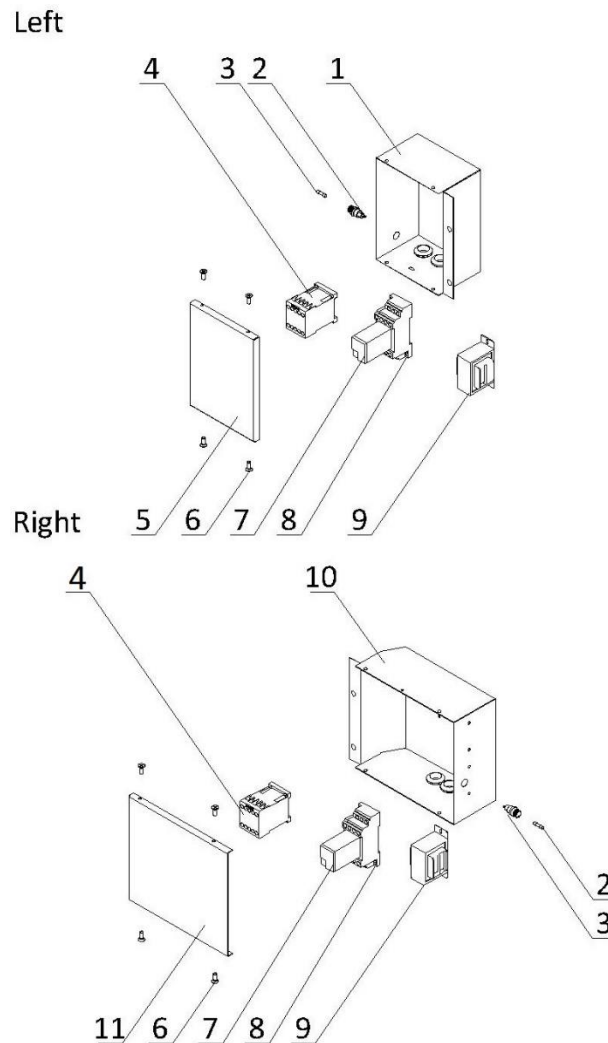

| Item | Part Number | Description | Qty. |
|------|-------------------------------|---|------|
| 1 | 2.2.4.18.0001 | Electrical Box Left - 6250-C/6250-AC | 1 |
| 2 | 3.1.02.08.012 | Seat - Fuse - 250V | 2 |
| 3 | 3.1.02.08.002 | Fuse - 0.5A | 2 |
| 4 | 3.1.01.01.010 | Contactor - 220V - 3RT6017-1AN21 | 2 |
| 5 | 2.2.4.21.0001 | Cover - Electrical Box Left - 6250-C/6250-AC | 1 |
| 6 | 3.6.19.001 | Screw - M4x8 | 8 |
| 7 | 3.1.01.03.029 | Intermediate Relay - AC220V - HH54P-L | 2 |
| 8 | 3.1.01.03.031 | Base - Relay - TP514X1-E | 2 |
| 9 | 3.1.01.04.007 | Transformer - 50W - 50313MW-32 | 2 |
| 10 | 2.2.4.19.0001 | Electrical Box Right - 6250-C/6250-AC | 1 |
| 11 | 2.2.4.22.0001 | Cover - Electrical Box Right - 6250-C/6250-AC | 1 |