

### 1. External Parts

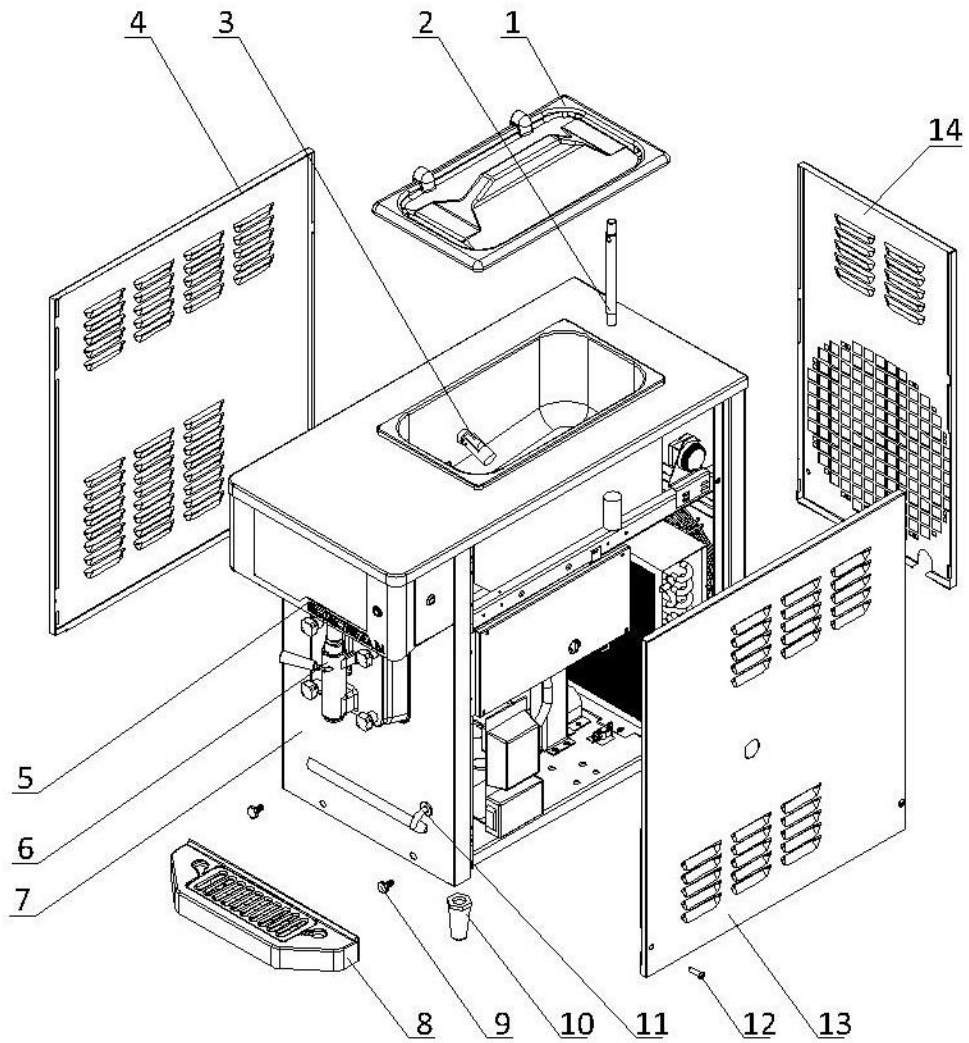

## 1. External Parts

Item	Part Number	Description	Qty.
1	3.4.03.01.004	Hopper Lid - 12-15L	1
2	2.1.3.39.0006	Air Tube - FB	1
3	920.1.04.0002	Mix Low Sensor Assembly	1
4	2.3.4.28.092	Panel - Left - 6450-CL	1
5	Page 6	Draw Switch and Front Control Panel	1
6	Page 5	Dispensing Door and Beater	1
7	2.3.4.26.088	Panel - Lower Front - 6450-CL	1
8	3.4.04.01.018	Front Drip Tray - 372mm - V3	1
9	3.6.39.004	Drip Tray Mounting Bolt	2
10	3.3.05.03.005	Leg - 68mm	4
11	2.1.1.20.0124	Drain Nozzle - Front	1
12	3.6.22.030	Screw - M6x25	6
13	2.3.4.30.076	Panel - Right - 6450-CL	1
14	2.3.4.23.103	Panel - Rear - 6450-CL	1

**2. Internal Parts**

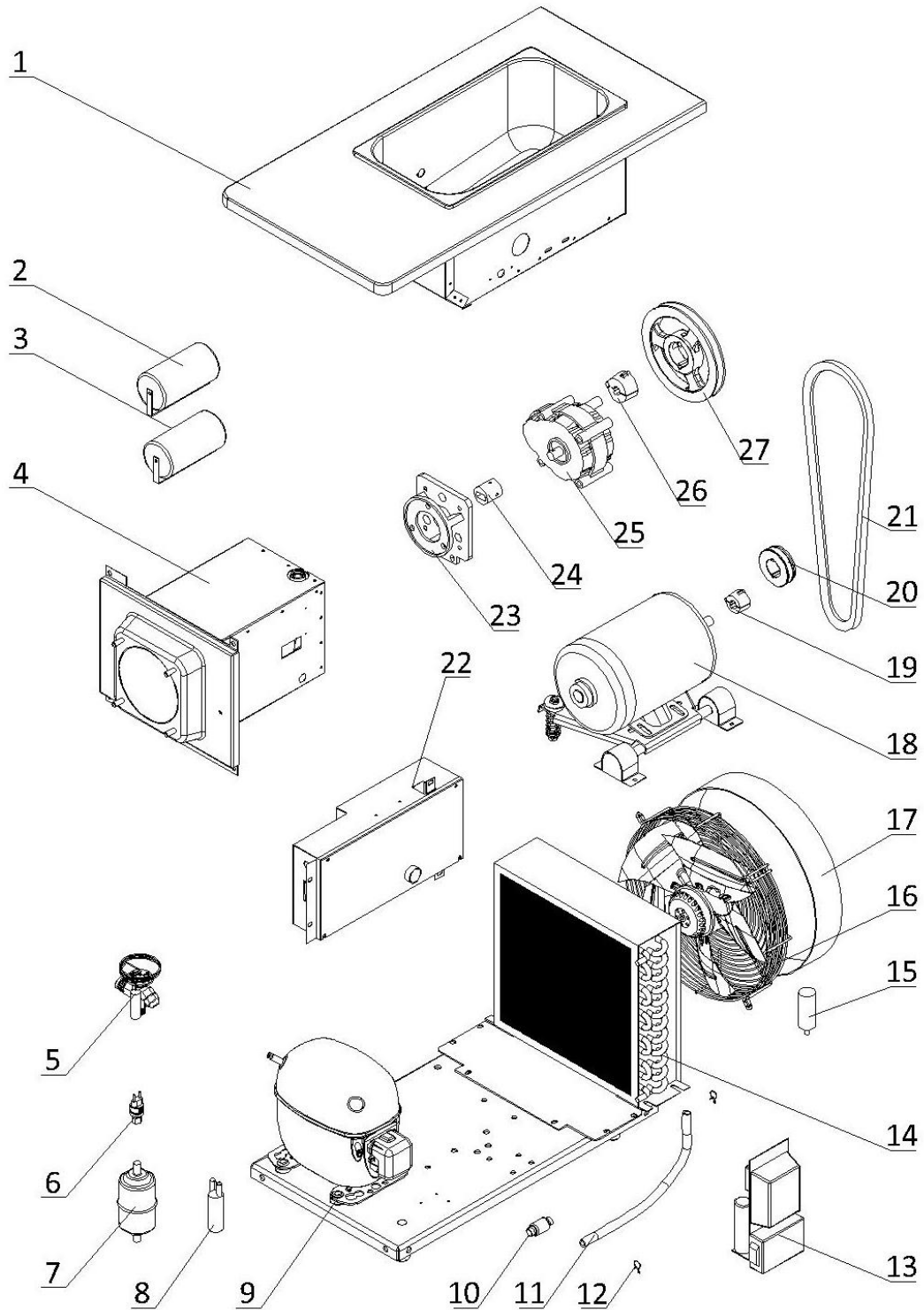

## 2. Internal Parts

Item	Part Number	Description	Qty.
1	2.1.1.02.0080	Hopper Assembly - 6450-CL	1
2	3.1.02.22.008	Capacitor - Running - 250V - 100~120μF	1
3	3.1.02.22.060	Capacitor - Start - 330V - 30μF	1
4	2.1.1.06.0160	Cylinder Assembly - 6450-CL	1
5	3.2.04.01.011	Thermal Expansion Valve - TUB2131	1
6	3.2.04.06.004	High Pressure Switch - 350~500psi	1
7	3.2.04.05.002	Filter Drier - Cylinder - DML083S	1
8	3.2.04.07.002	Suction Accumulator - 30×155×10	1
9	3.2.01.02.028.A	Primary Compressor - SC18CLX.2	1
10	3.2.04.05.012	Copper Strainer Filter - φ9.52	1
11	3.7.06.025-1	Drain Hose - φ9×14 - 330mm	1
12	3.6.05.024	Squeeze Clamp - Drain Hose - M13	2
13	3.2.01.04.014	Start Component - Compressor - SC18CLX.2	1
14	3.2.02.01.003	Main Condenser - Single - 5m <sup>2</sup> - 375x325x100	1
15	3.2.03.04.003-2	Capacitor - Fan Motor - 450V - 10μF - CBB60	1
16	3.2.03.04.003	Fan Motor - 110/60/1 - YWF4E-300S	1
17	2.1.3.50.0001	Fan Shroud - 108cm	1
18	3.3.01.07.008	Motor - 110/60/1 - 1/4HP	1
19	3.3.04.01.002	Bushing - 1008-14	1
20	3.3.04.02.012	Pulley - Beater Motor - SPA63-1-1008	1
21	3.3.03.03.017	Belt - Motor to Beater - V-A737	1
22	Page 7	Electrical Box	1
23	2.1.3.15.0003	Bracket - Gear Box - 3.4-7.3qt - 79mm	1
24	3.3.02.03.006	Coupling Drive - 3.4qt-4.0qt-7.3qt - 20mm - V3	1
25	3.3.02.01.024	Gear Box - 1:4.94 - 45*20 Shaft - 79mm	1
26	3.3.04.01.008	Bushing - 1610-16	1
27	3.3.04.02.020	Pulley - Gear Box - SPA160-1-1610	1

### 3. Dispensing Door and Beater

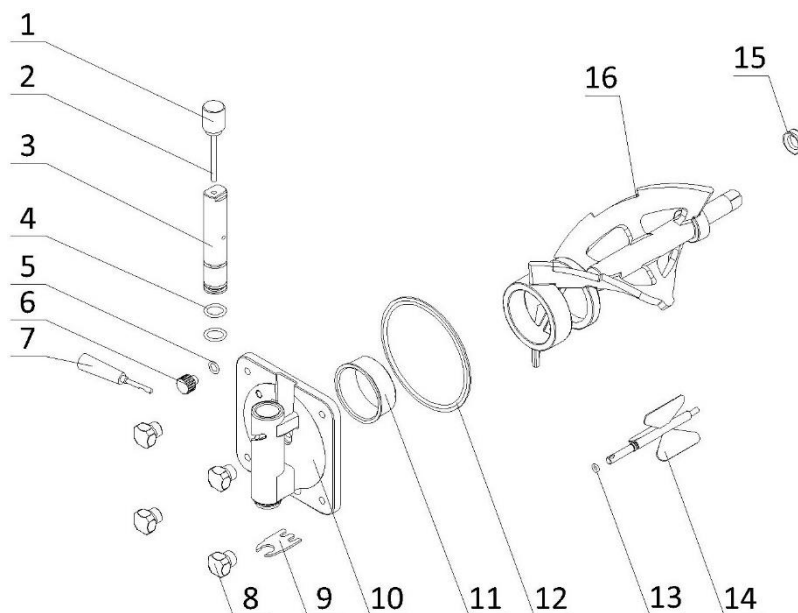

Item	Part Number	Description	Qty.
1	<a href="#">2.1.3.36.0004</a>	Weight - Draw Valve - FB	1
2	<a href="#">2.1.3.36.0003</a>	Pin - Draw Valve - FB	1
3	<a href="#">2.1.3.01.0006</a>	Draw Valve - FB	1
4	<a href="#">3.4.08.01.036</a>	O-Ring - 19x3.55	2
5	<a href="#">3.4.08.01.008</a>	O-Ring - 11.5x2.5	1
6	<a href="#">3.4.07.08.001</a>	Prime Plug - FB	1
7	<a href="#">3.4.05.01.002</a>	Handle - Dispensing - FB	1
8	<a href="#">2.1.3.32.0004</a>	Hand Screw - Dispensing - FB	4
9	<a href="#">2.1.4.04.014</a>	Ice Buster - Dispensing - FB	1
10	<a href="#">2.1.3.14.0006</a>	Dispensing Door - FB	1
11	<a href="#">3.4.01.03.016</a>	Beater Guide - FB - V3	1
12	<a href="#">3.4.08.02.012</a>	Door Gasket - FB - V2	1
13	<a href="#">3.4.08.01.017</a>	O-Ring - 11x2.4	1
14	<a href="#">2.1.1.31.0008</a>	Torque Rotor - FB - V4	1
15	<a href="#">3.4.07.05.007</a>	Gasket - Beater - φ35	1
16	<a href="#">2.1.1.25.0018</a>	Beater - FB - 4.0qt - V3	1

## 4. Draw Switch and Front Control Panel

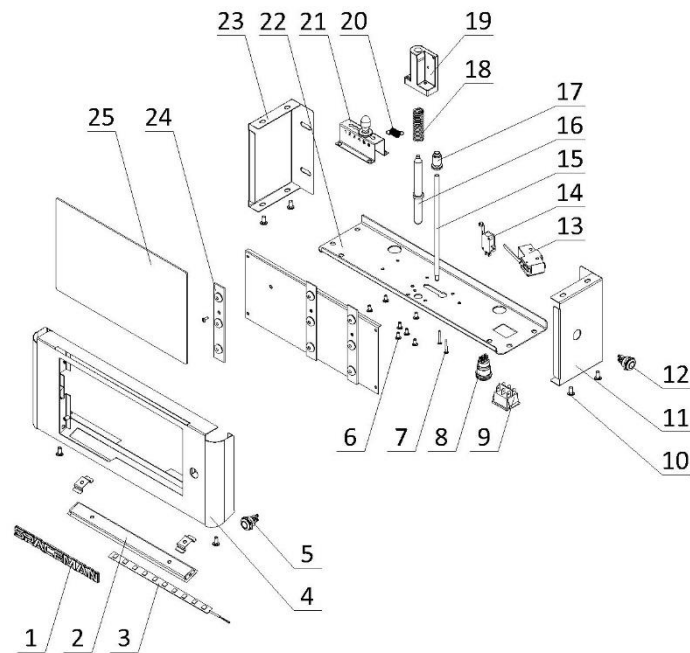

Item	Part Number	Description	Qty.
1	3.1.06.09.003	Emblem - SPACEMAN - 170x16	1
2	3.6.42.005	Bracket - LED Light Strip - 1707A - 231	1
3	3.1.02.14.020	LED Light Strip - STH-2835W-120D-12V-12W - 6000K	1
4	2.1.1.20.0149	Panel - Overhead Front - 6450/6650-CL	1
5	3.1.02.14.014	RGB Light - YM16/ZST/12V/3S+	1
6	3.6.22.028	Screw - M4x12	7
7	3.6.22.027	Screw - M4x30	2
8	3.1.03.04.039	Button Switch - QN19-C7	1
9	<a href="#">3.1.03.03.009</a>	Rocker Switch - RK1-01 2X3	1
10	3.6.22.010	Screw - M5x10	6
11	2.3.4.37.070	Panel - Overhead Side - 6450/6455/6650-CL	1
12	3.1.03.04.046	Button Switch - QN16-A3	1
13	<a href="#">3.1.03.02.002</a>	Micro Switch - Torque Lever	1
14	<a href="#">3.1.03.01.002</a>	Micro Switch - KW-7-2	1
15	2.1.4.04.025	Torque Arm - 185mm	1
16	<a href="#">2.1.3.50.0088</a>	Shaft - Draw Switch - 120.3mm	1
17	<a href="#">2.1.4.04.024</a>	Bracket - Spring - FB	1
18	<a href="#">3.6.03.012</a>	Spring - Shaft - Draw Switch	1
19	<a href="#">3.4.07.06.008</a>	Bracket - Micro Switch&Shaft&Spring	1
20	3.6.02.005	Spring - Viscosity - 0.7mm	1
21	<a href="#">920.1.03.0004</a>	Control Levers - Viscosity Adjustment - V2	1
22	2.3.4.39.100	Panel - Overhead Bottom - 6450/6650-CL	1
23	2.3.4.37.069	Panel - Overhead Side - 6450/6650-CL	1
24	3.1.02.14.025	LED Light Bar - STH-B12T130W3B170 - 6500K - 12V	3
25	3.4.07.10.005	Flavor Panel - 264x160	1

## 5. Electrical Box

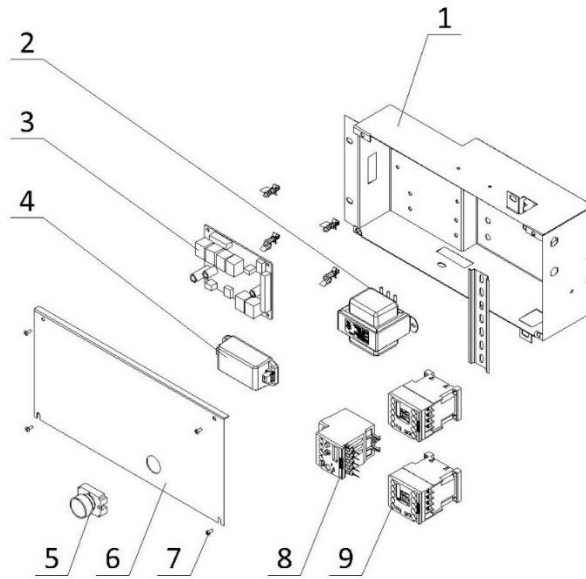

Item	Part Number	Description	Qty.
1	2.2.4.17.0119	Electrical Box - 6450/6650-CL	1
2	3.1.01.04.014	Transformer - 50W - LTT5032OF-31	1
	<a href="#">3.1.01.04.007</a>	Transformer - 50W - 50313MW-32 (Alternative)	1
3	2.2.1.01.0051	Control Board - FB - F5	1
4	3.1.01.05.034	Power Supply - MPM-30-12ST	1
5	<a href="#">3.1.03.04.002</a>	Reset Button - Thermal Overload	1
6	2.2.4.20.0104	Cover - Electrical Box - 6450/6650-CL	1
7	3.6.19.001	Screw - M4x8	4
8	<a href="#">3.1.01.02.012</a>	Thermal Overload Relay - 3RU6116-1HB0	1
9	<a href="#">3.1.01.01.011</a>	Contactor - 3RT6017-1AF01	2