

1. External Parts

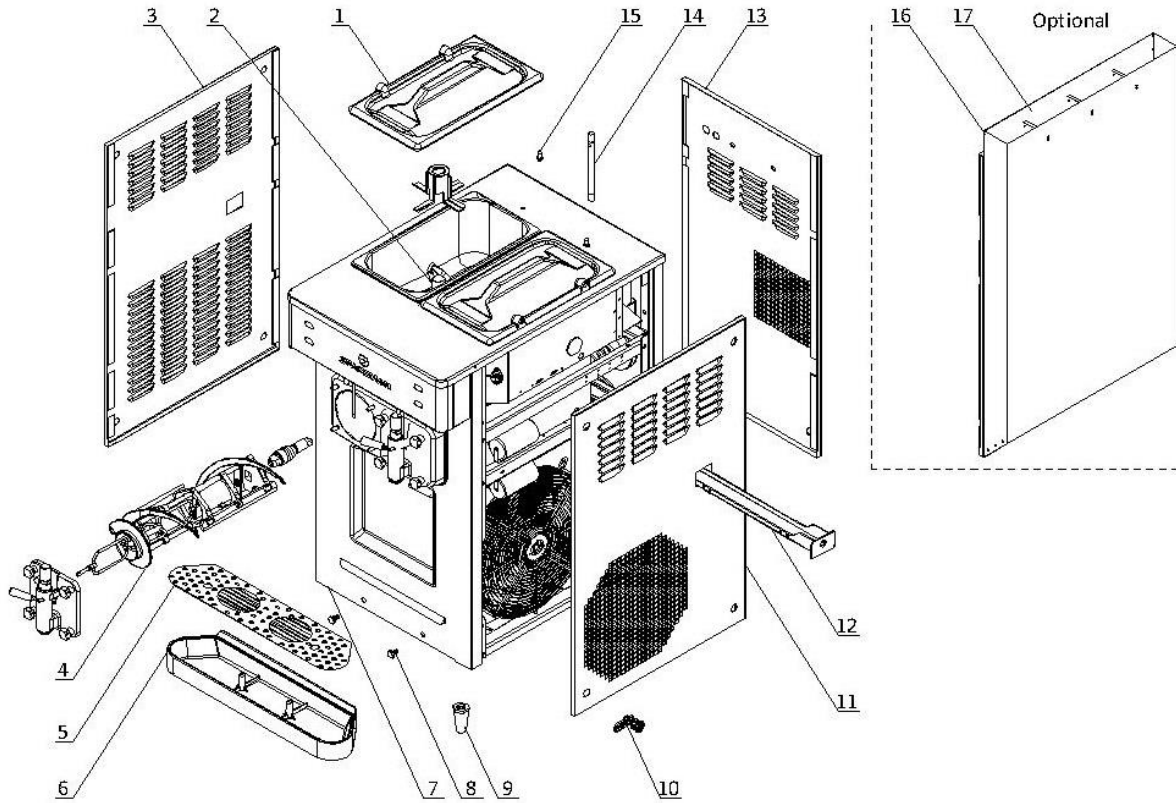

1. External Parts

Item	Part Number	Description	Qty.
1	3.4.03.01.004	Hopper Lid - 12-15L	2
2	Page 7	Hopper Agitator	2
3	2.3.4.18.046	Panel - Left - 6695-C	1
4	Page 5	Dispensing Door and Beater	2
5	2.3.4.45.304	Splash Shield - Front Drip Tray - 58mm - White - D	1
6	3.4.04.01.010	Front Drip Tray - 58mm - White	1
7	2.3.4.16.048	Panel - Lower Front - 6695-C	1
8	3.6.39.004	Drip Tray Mounting Bolt	2
9	3.3.05.03.005	Leg - 68mm	4
10	8.1.07.001	Panel Lock Assembly	12
11	2.3.4.20.039	Panel - Right - 6695-C	1
12	3.4.04.02.001	Internal Drip Tray - 45mm	1
13	2.3.4.13.013	Panel - Rear - 6695-C	1
14	2.1.3.39.0006	Air Tube - FB	2
15	3.6.39.011	Hopper Lid Holder	2
16	2.3.4.20.042	Panel - Right - Air Chute - 6695-C (Optional)	1
17	2.3.4.34.025	Air Chute - 6695-C (Optional)	1

2. Internal Parts

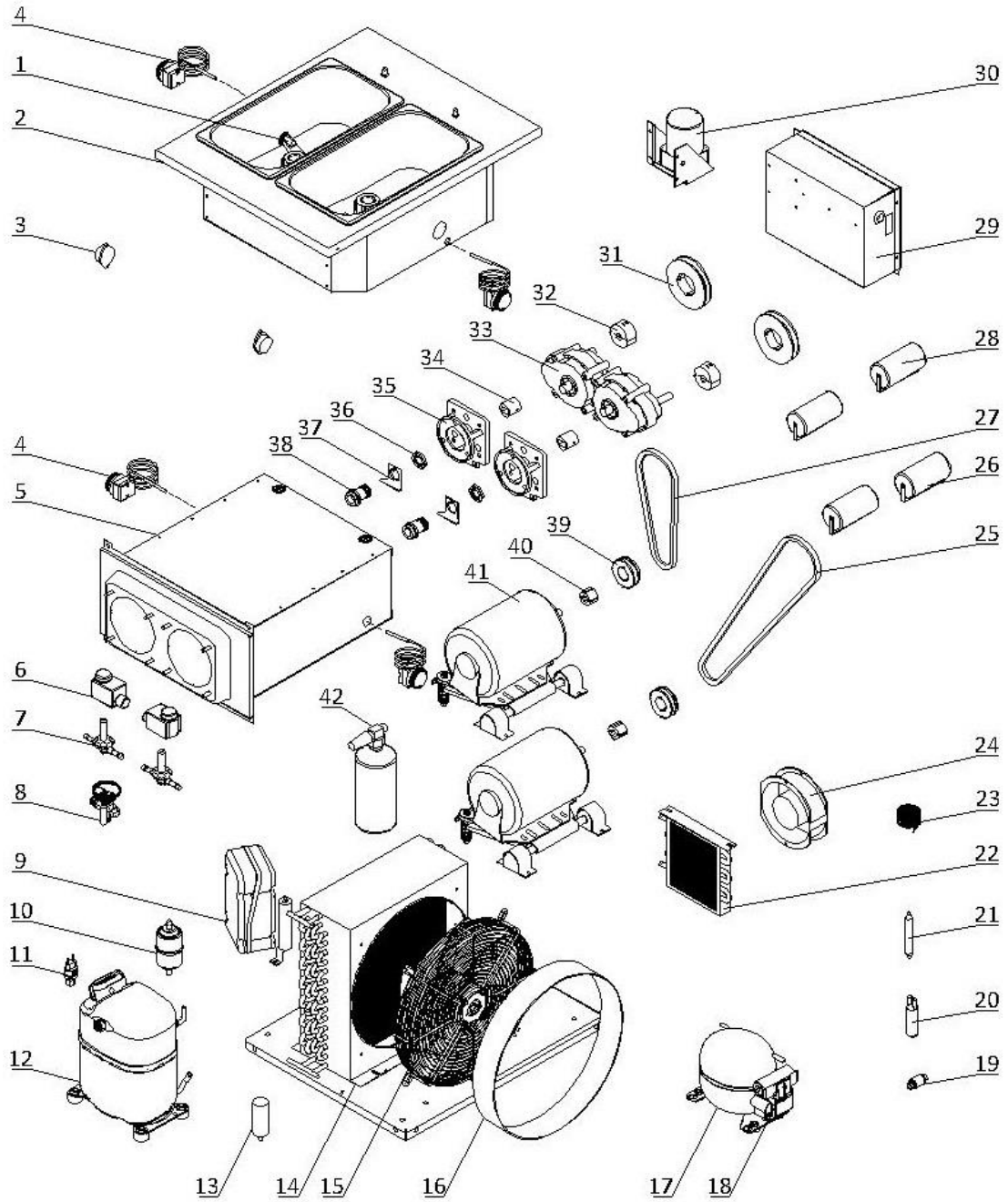

2. Internal Parts

Item	Part Number	Description	Qty.
1	920.1.04.0002	Mix Low Sensor Assembly	2
2	2.1.1.03.0053	Hopper Assembly - 6695-C	1
3	3.1.02.15.003	Alarm - Low Mix - DC3-24V	2
4	3.1.01.07.003	Thermostat - 0-40°C	4
5	2.1.1.06.0119	Cylinder Assembly - 6695-C	1
6	3.2.04.04.015	Solenoid Coil - 1068	2
7	3.2.04.04.002	Solenoid Valve Body - 1068	2
8	3.2.04.01.013	Thermal Expansion Valve - TUB2134	1
9	3.2.01.04.004	Start Component - Compressor - CAJ2464Z	1
	3.2.01.04.024	Start Component - Compressor - CAJ4519Z (Alternative)	1
10	3.2.04.05.002	Filter Drier - Cylinder - DML083S	1
11	3.2.04.06.004	High Pressure Switch - 350~500psi	1
12	3.2.01.02.005.A	Primary Compressor - CAJ2464Z	1
	3.2.01.02.042.A	Primary Compressor - CAJ4519Z (Alternative)	1
13	3.2.03.04.001-2	Capacitor - Fan Motor - 450V - 5µF - CBB60	1
14	3.2.02.01.007	Main Condenser - Single - 10m ²	1
15	3.2.03.04.001	Fan Motor - 220/60/1 - YWF4E-350S	1
16	2.1.3.50.0002	Fan Shroud - 120mm	1
17	3.2.01.01.002.A	Auxiliary Compressor - EM30HHR	1
18	3.2.01.01.002-1	Start Component - Compressor - EM30HHR	1
19	3.2.04.05.010	Copper Strainer Filter - φ12	1
20	3.2.04.07.001	Suction Accumulator - 25×100×0.6	1
21	3.2.04.05.001	Filter Drier - Hopper - 16×2.2×120	1
22	3.2.02.01.001	Auxiliary Condenser - Single - 0.7m ²	1
23	3.2.05.01.003	Capillary Tube - 2.2×0.9	1
24	3.2.03.01.001	Fan Motor - BT220-15050S2HL	1
	3.2.03.01.005	Fan Motor - UF-1751B22H (Alternative)	1
25	3.3.03.03.019	Belt - Motor - Beater - V-A1245	1
26	3.1.02.22.062	Capacitor - Start - 330V - 160µF	2
27	3.3.03.03.015	Belt - Motor - Beater - V-A660	1
28	3.1.02.22.009	Capacitor - Running - 370V - 25µF	2
29	Page 8	Electrical and Power Control Box	1
30	Page 7	Agitator Motor Assembly	1
31	3.3.04.02.006	Pulley - Gear Box - SPA112-1-1610	2
32	3.3.04.01.008	Bushing - 1610-16	2
33	3.3.02.01.024	Gear Box - FB - 45*20 Shaft - 79mm	2
34	3.3.02.04.009	Coupling Drive - 3.4qt-4.0qt-7.3qt - 20mm - V2	2
35	2.1.3.15.0003	Bracket - Gear Box - 3.4-7.3qt - 79mm	2
36	3.3.02.02.010	Nut - Rear Shell Bearing	2
37	2.3.6.04.004	Lock Plate - Rear Shell Bearing - 42mm	2
38	3.3.02.02.002	Rear Shell Bearing - SS (3.4qt) + FB	2
39	3.3.04.02.012	Pulley - Beater Motor - SPA63-1-1008	2
40	3.3.04.01.005	Bushing - 1008-16	2
41	3.3.01.07.010	Motor - 220/60/1 - 450W - K56AC66AF41	2
42	3.2.04.08.001	liquid Receiver - 76x280	1

3. Dispensing Door and Beater

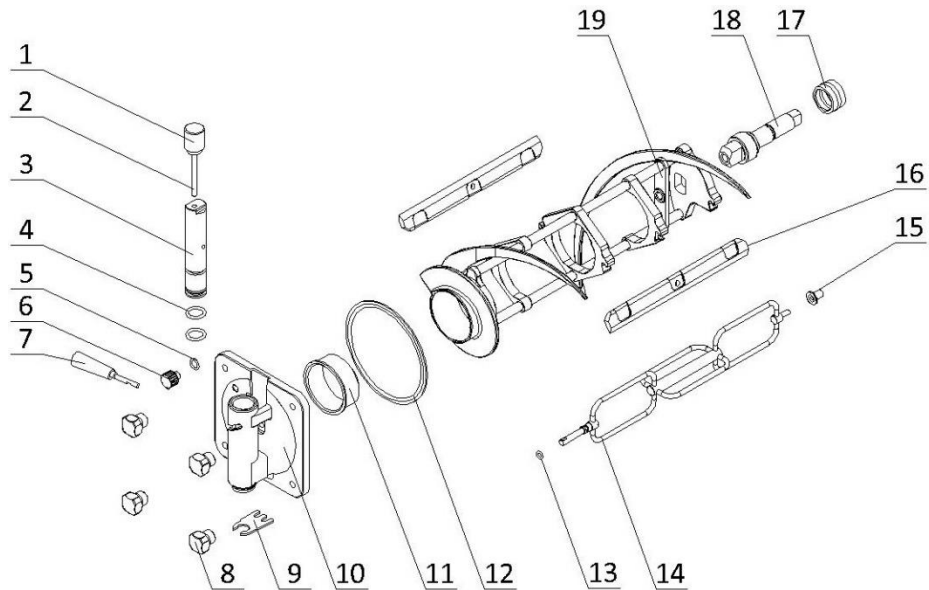

Item	Part Number	Description	Qty.
1	2.1.3.36.0004	Weight - Draw Valve - FB	2
2	2.1.3.36.0003	Pin - Draw Valve - FB	2
3	2.1.3.01.0006	Draw Valve - FB	2
4	3.4.08.01.036	O-Ring - 19x3.55	4
5	3.4.08.01.008	O-Ring - 11.5x2.5	2
6	3.4.07.08.001	Prime Plug - FB	2
7	3.4.05.01.002	Handle - Dispensing - FB	2
8	2.1.3.32.0004	Hand Screw - Dispensing - FB	8
9	2.1.4.04.014	Ice Buster - Dispensing - FB	2
10	2.1.3.14.0006	Dispensing Door - FB	2
11	3.4.01.03.003	Beater Guide - FB	2
12	3.4.08.02.005	Door Gasket - FB	2
13	3.4.08.01.017	O-Ring - 11x2.4	2
14	2.1.1.31.0003	Torque Rotor - 7.3qt - V2	2
15	3.4.01.03.012	Torque Guide - V2	2
16	3.4.02.01.006	Scraper Blade - FB - V2	4
17	3.4.07.05.002	Gasket - Drive Shaft	4
18	2.1.3.25.0003	Drive Shaft - FB	2
19	2.1.1.10.0020	Beater - FB - Standard - V2	2

4. Draw Switch and Front Control Panel

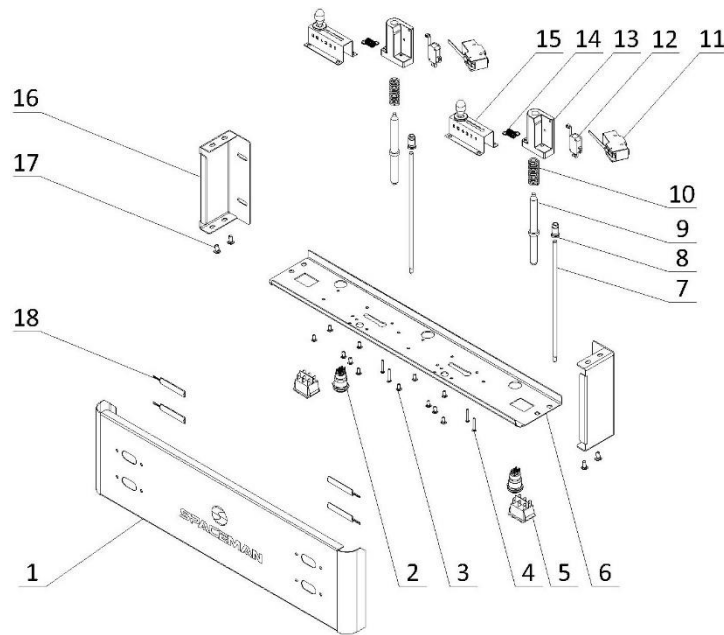

Item	Part Number	Description	Qty.
1	2.3.4.33.040	Panel - Overhead Front - 6695-C	1
2	3.1.03.04.035	Switch - FT19QB-H22Z/S-K13P0	2
3	3.6.22.028	Screw - M4x12	12
4	3.6.22.027	Screw - M4x30	4
5	3.1.03.03.009	Power Switch - RK1-01 2X3	2
6	2.3.4.39.065	Panel - Overhead Bottom - 6695-C	1
7	2.1.4.04.025	Torque Arm - 185mm	2
8	2.1.4.04.024	Bracket - Spring - 6690-C	2
9	2.1.3.50.0088	Shaft - Draw Switch - FB - 120.3mm	2
10	3.6.03.012	Spring - Shaft - Draw Switch	2
11	3.1.03.02.002	Micro Switch - Torque Lever	2
12	3.1.03.01.002	Micro Switch - KW-7-2	2
13	3.4.07.06.008	Bracket - Micro Switch & Shaft & Spring	2
14	3.6.02.005	Spring - Viscosity 0.7mm	2
15	920.1.03.0004	Control Levers - Viscosity Adjustment - V2	2
16	2.3.4.37.045	Panel - Overhead Side - FB	2
17	3.6.22.010	Screw - M5x10	4
18	3.1.02.14.005	LED Light - XGJ	4

5. Hopper Agitator

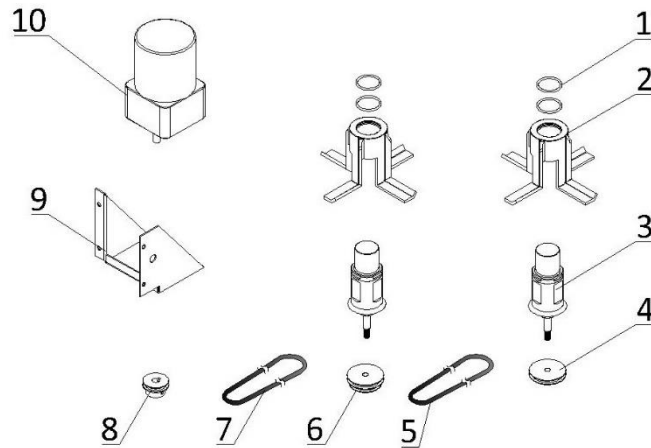

Item	Part Number	Description	Qty.
1	3.4.08.01.034	O-Ring - 31×2	4
2	2.1.1.23.0002	Blade - Hopper Agitator - Standard - V2	2
3	2.1.1.12.0001	Agitator Assembly - 129mm	2
4	2.1.4.02.015	Pulley - Hopper Agitator - Single - 53mm	1
5	2.1.4.08.003	Belt - Hopper Agitator - 600mm	1
6	2.1.4.02.016	Pulley - Hopper Agitator - Double - 53mm	1
7	2.1.4.08.051	Belt - Hopper Agitator - 880mm	1
8	3.3.04.04.006	Pulley - Hopper Agitator - Drive - 30mm	1
9	2.3.4.45.339	Bracket - Agitator Motor - 6695/6695-C	1
10	3.3.01.01.006	Motor - Agitator - 220V - YN80-25-6G	1

6. Electrical and Power Control Box

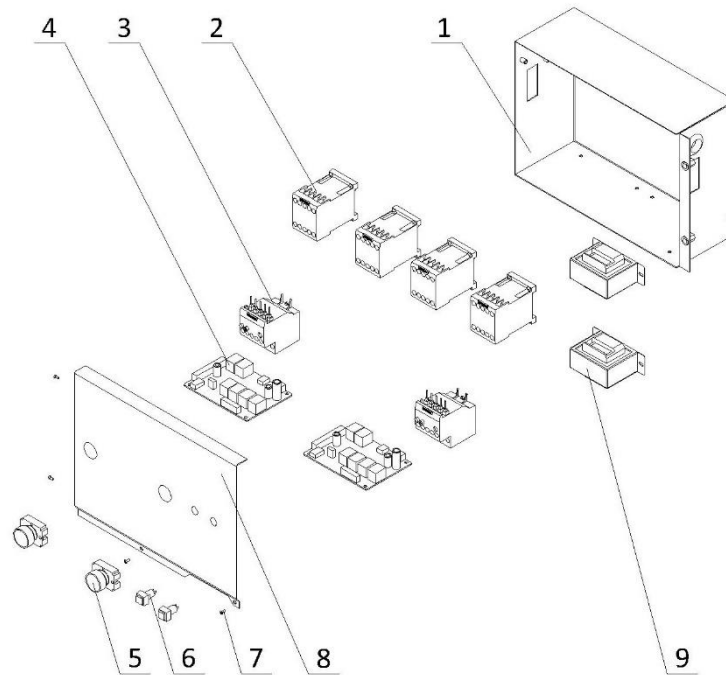

Ite	Part Number	Description	Qty.
1	2.2.4.17.0027	Electrical Box - 6695/6695-C	1
2	3.1.01.01.010	Contactor - 220V - 3RT6017-1AN21	4
3	3.1.01.02.010	Thermal Overload Relay - 3RU6116-1EB0	2
4	2.1.1.30.0012	Control Board - FB	2
5	3.1.03.04.002	Reset Button - Thermal Overload	2
6	3.1.03.04.003	Switch - FB - Low Mix Alarm - Green Square	2
7	3.6.22.005	Screw - M4X10	4
8	2.2.4.20.0027	Cover - Electrical Box - 6695/6695-C	1
9	3.1.01.04.007	Transformer - 50W - 50313MW-32	2