

1. External Parts

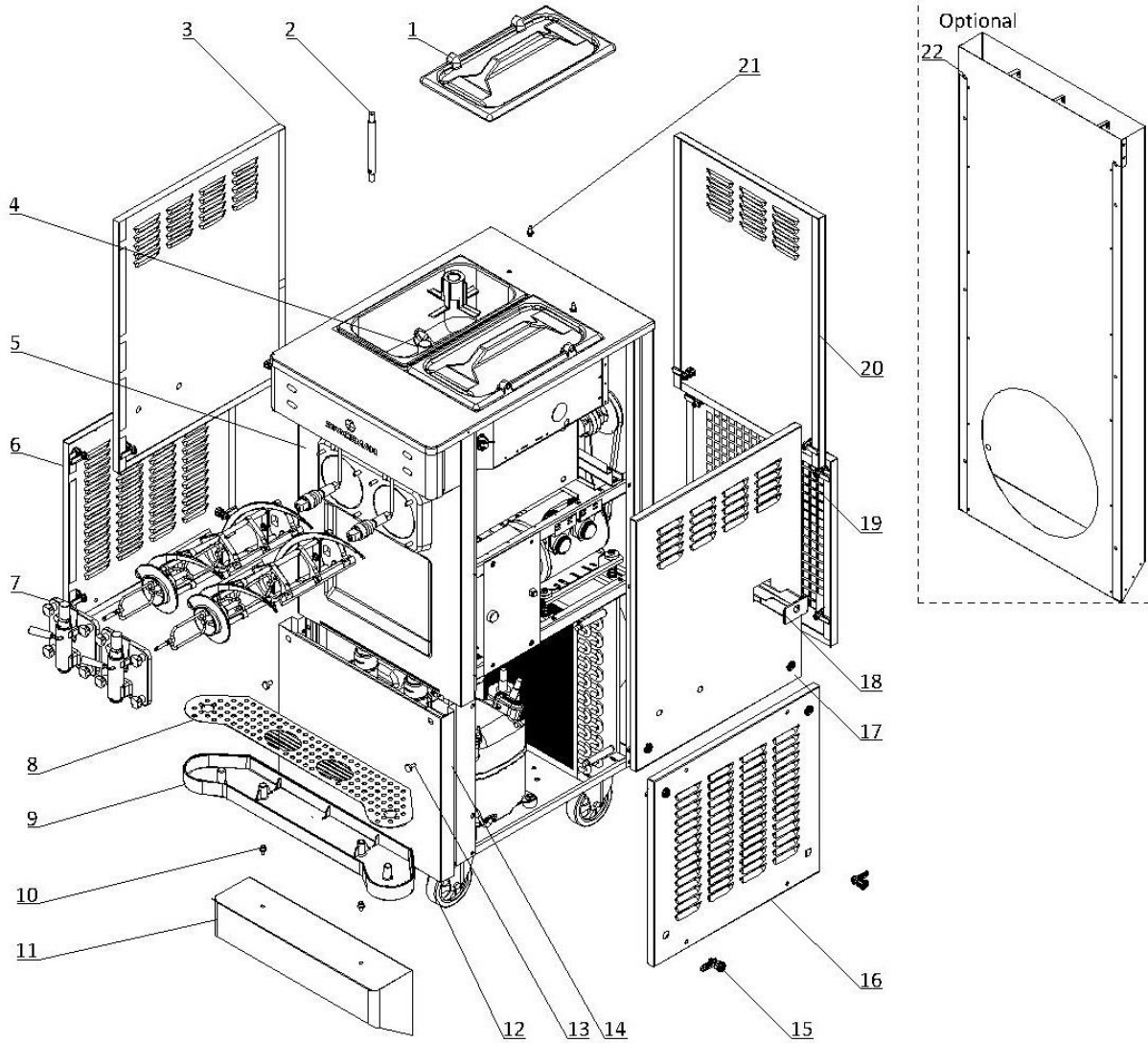

1. External Parts

Item	Part Number	Description	Qty.
1	3.4.03.01.004	Hopper Lid - 12-15L	2
2	2.1.3.39.0006	Air Tube - FB	2
3	2.3.4.19.010	Panel - Upper Left - 6795-C	1
4	Page 7	Hopper Agitator	2
5	2.3.4.16.001	Panel - Middle Front - 6795-C	1
6	2.3.4.35.004	Panel - Lower Left - 6795-C	1
7	Page 5	Dispensing Door and Beater	2
8	2.3.4.45.089	Splash Shield - Front Drip Tray - 68mm	1
9	3.4.04.01.009	Front Drip Tray - 68mm	1
10	3.6.39.003	Mounting Bolt - Support - Front Drip Tray - 6795-C	2
11	2.3.4.45.087	Support - Front Drip Tray - 6795-C	1
12	3.3.05.02.002	Caster Swivel - 125X34	4
13	3.6.39.004	Drip Tray Mounting Bolt	2
14	2.3.4.17.019	Panel - Lower Front - 6795-C	1
15	8.1.07.001	Panel Lock Assembly	18
16	2.3.4.22.006	Panel - Lower Right - 6795-C	1
17	2.3.4.21.006	Panel - Upper Right - 6795-C	1
18	3.4.04.02.001	Internal Drip Tray - 45mm	1
19	2.3.4.15.004	Panel - Lower Rear - 6795	1
20	2.3.4.14.004	Panel - Upper Rear - 6795	1
21	3.6.39.011	Hopper Lid Holder	2
22	2.3.4.34.008	Air Chute Assembly - 6795-C (Optional)	1

2. Internal Parts

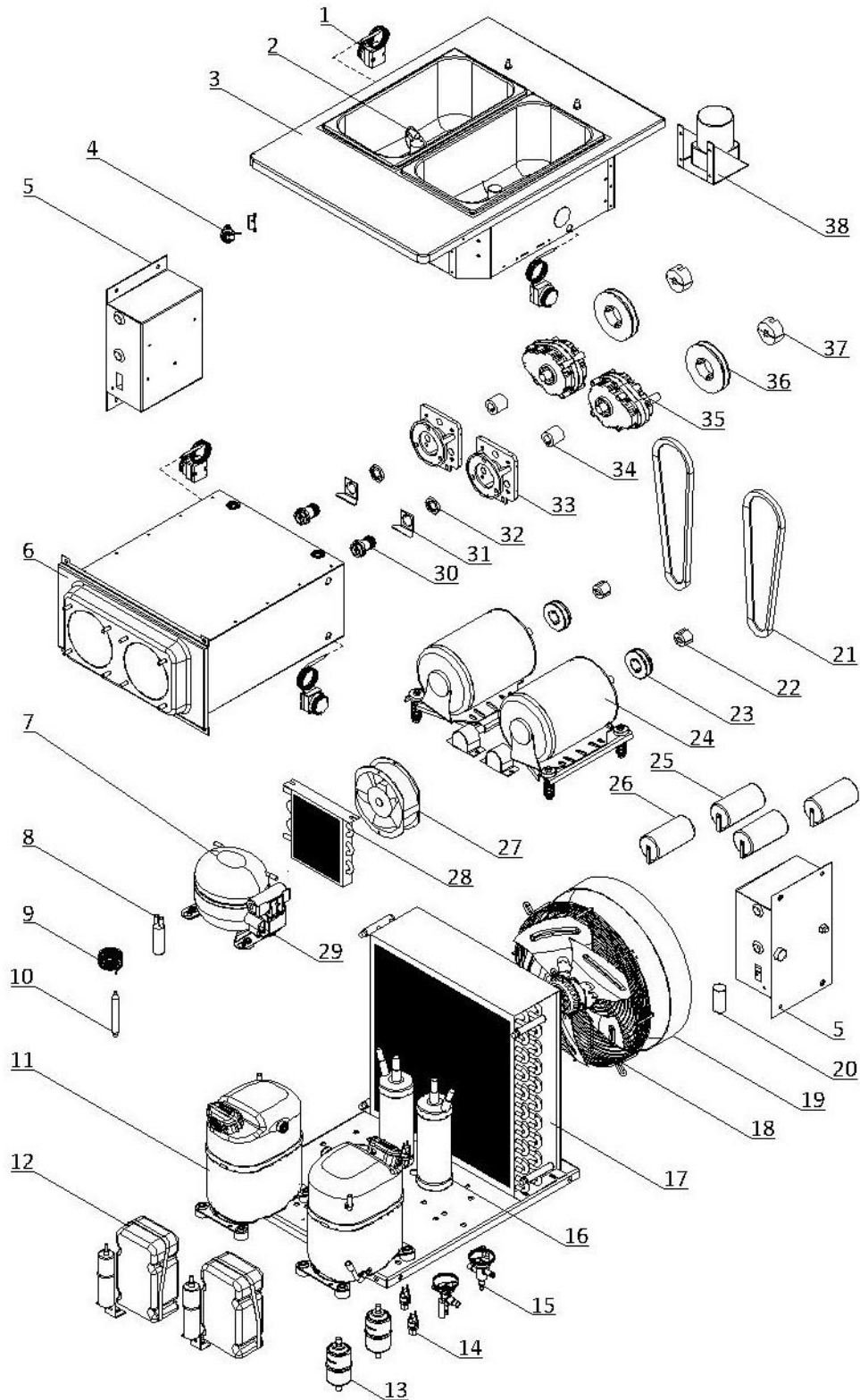

2. Internal Parts

Item	Part Number	Description	Qty.
1	3.1.01.07.003	Thermostat - 0-40°C	4
2	920.1.04.0002	Mix Low Sensor Assembly	2
3	2.1.1.03.0085	Hopper Assembly - 6795-C	1
4	3.1.02.15.003	Alarm - Low Mix - DC3-24V	2
5	Page 8	Electrical Box	2
6	2.1.1.06.0034	Cylinder Assembly - 6795-C	1
7	3.2.01.01.002.A	Auxiliary Compressor - EM30HHR	1
8	3.2.04.07.001	Suction Accumulator - 25×100×0.6	1
9	3.2.05.01.003	Capillary Tube - 2.2×0.9	1
10	3.2.04.05.001	Filter Drier - Hopper - 16×2.2×120	1
11	3.2.01.02.005.A	Primary Compressor - CAJ2464Z	2
12	3.2.01.04.004	Start Component - Compressor - CAJ2464Z	2
13	3.2.04.05.002	Filter Drier - Cylinder - DML083S	2
14	3.2.04.06.004	High Pressure Switch - 350~500psi	2
15	3.2.04.01.013	Thermal Expansion Valve - TUB2134	2
16	3.2.04.08.001	liquid Receiver - 76x280	2
17	3.2.02.01.011	Main Condenser - Dual - 20m ²	1
18	3.2.03.04.001	Fan Motor - 220/60/1 - YWF4E-350S	1
19	2.1.3.50.0002	Fan Shroud - 120mm	1
20	3.2.03.04.001-2	Capacitor - Fan Motor - 450V - 5μF - CBB60	1
21	3.3.03.01.018	Belt - Motor to Beater - V-XPA982	2
22	3.3.04.01.005	Bushing - 1008-16	2
23	3.3.04.02.012	Pulley - Beater Motor - SPA63-1-1008	2
24	3.3.01.07.010	Motor - 220/60/1 - 450W - K56AC66AF41	2
25	3.1.02.22.062	Capacitor - Start - 330V - 160μF	2
26	3.1.02.22.009	Capacitor - Running - 370V - 25μF	2
27	3.2.03.01.001	Fan Motor - BT220-15050S2HL	1
28	3.2.02.01.001	Auxiliary Condenser - Single - 0.7m ²	1
29	3.2.01.01.002-1	Start Component - Compressor - EM30HHR	1
30	3.3.02.02.002	Rear Shell Bearing - SS (3.4qt) + FB	2
31	2.3.6.04.004	Lock Plate - Rear Shell Bearing - 42mm	2
32	3.3.02.02.010	Nut - Rear Shell Bearing	2
33	2.1.3.15.0003	Bracket - Gear Box - 3.4-7.3qt - 79mm	2
34	3.3.02.04.009	Coupling Drive - 3.4qt-4.0qt-7.3qt - 20mm - V2	2
35	3.3.02.01.024	Gear Box - FB - 45*20 Shaft - 79mm	2
36	3.3.04.02.011	Pulley - Gear Box - SPA 168-1-1210	2
37	3.3.04.01.007	Bushing - 1210-16	2
38	Page 7	Agitator Motor Assembly	1

3. Dispensing Door and Beater

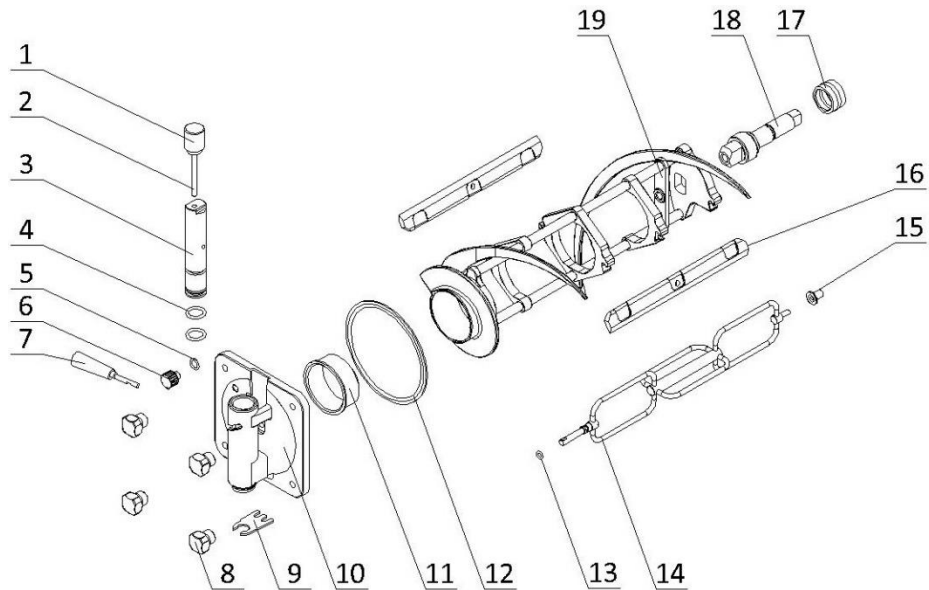

Item	Part Number	Description	Qty.
1	2.1.3.36.0004	Weight - Draw Valve - FB	2
2	2.1.3.36.0003	Pin - Draw Valve - FB	2
3	2.1.3.01.0006	Draw Valve - FB	2
4	3.4.08.01.036	O-Ring - 19x3.55	4
5	3.4.08.01.008	O-Ring - 11.5x2.5	2
6	3.4.07.08.001	Prime Plug - FB	2
7	3.4.05.01.002	Handle - Dispensing - FB	2
8	2.1.3.32.0004	Hand Screw - Dispensing - FB	8
9	2.1.4.04.014	Ice Buster - Dispensing - FB	2
10	2.1.3.14.0006	Dispensing Door - FB	2
11	3.4.01.03.003	Beater Guide - FB	2
12	3.4.08.02.005	Door Gasket - FB	2
13	3.4.08.01.017	O-Ring - 11x2.4	2
14	2.1.1.31.0003	Torque Rotor - 7.3qt - V2	2
15	3.4.01.03.012	Torque Guide - V2	2
16	3.4.02.01.006	Scraper Blade - FB - V2	4
17	3.4.07.05.002	Gasket - Drive Shaft	4
18	2.1.3.25.0003	Drive Shaft - FB	2
19	2.1.1.10.0020	Beater - FB - Standard - V2	2

4. Draw Switch and Front Control Panel

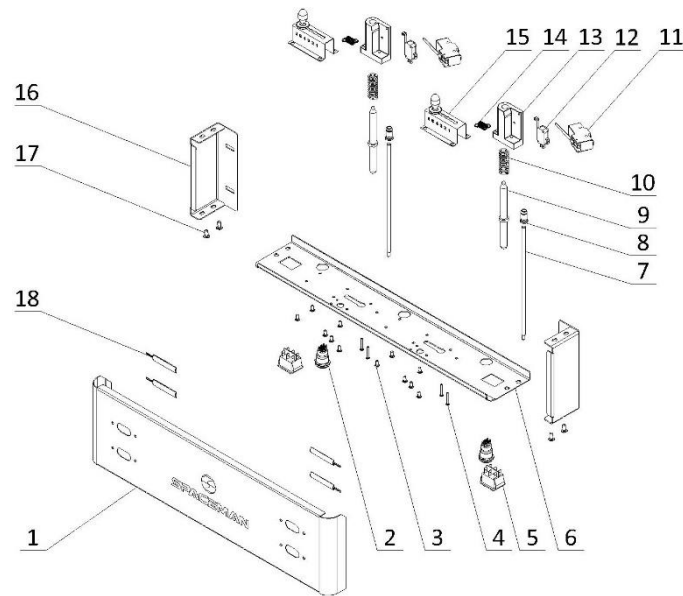

Item	Part Number	Description	Qty.
1	2.3.4.33.014	Panel - Overhead Front - 6795-C/6695-C	1
2	3.1.03.04.035	Switch - FT19QB-H22Z/S-K13P0	2
3	3.6.22.028	Screw - M4x12	14
4	3.6.22.027	Screw - M4x30	4
5	3.1.03.03.009	Power Switch - RK1-01 2X3	2
6	2.3.4.39.015	Panel - Overhead Bottom - 6795-C/6695-C	1
7	2.1.4.04.025	Torque Arm - 185mm	2
8	2.1.4.04.024	Bracket - Spring - 6690-C	2
9	2.1.3.50.0073	Shaft - Draw Switch - FB - 120.3mm	2
10	3.6.03.012	Spring - Shaft - Draw Switch	2
11	3.1.03.02.002	Micro Switch - Torque Lever	2
12	3.1.03.01.002	Micro Switch - KW-7-2	2
13	3.4.07.06.008	Bracket - Micro Switch & Shaft & Spring	2
14	3.6.02.005	Spring - Viscosity 0.7mm	2
15	920.1.03.0004	Control Levers - Viscosity Adjustment - V2	2
16	2.3.4.37.045	Panel - Overhead Side - FB	2
17	3.6.22.010	Screw - M5x10	4
18	3.1.02.14.005	LED Light - XGJ	4

5. Hopper Agitator

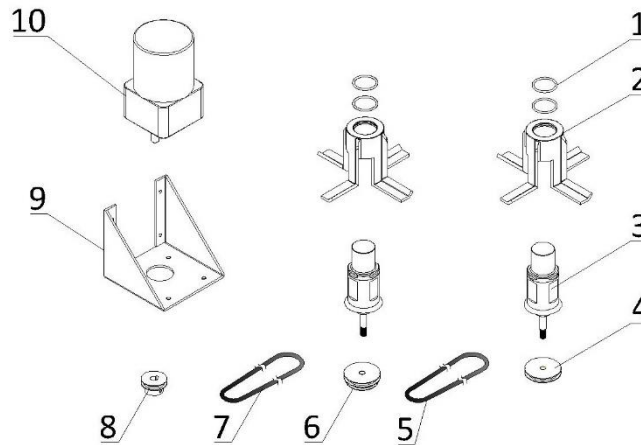

Item	Part Number	Description	Qty.
1	3.4.08.01.034	O-Ring - 31x2	4
2	2.1.1.23.0002	Blade - Hopper Agitator - Standard - V2	2
3	2.1.1.12.0001	Agitator Assembly - 129mm	2
4	2.1.4.02.015	Pulley - Hopper Agitator - Single - 53mm	1
5	2.1.4.08.003	Belt - Hopper Agitator - 600mm	1
6	2.1.4.02.016	Pulley - Hopper Agitator - Double - 53mm	1
7	2.1.4.08.050	Belt - Hopper Agitator - 660mm	1
8	3.3.04.04.006	Pulley - Hopper Agitator - Drive - 30mm	1
9	2.3.4.45.082	Bracket - Agitator Motor - 115mm	1
10	3.3.01.01.006	Motor - Agitator - 220V - YN80-25-6G	1

6. Electrical Box

Right

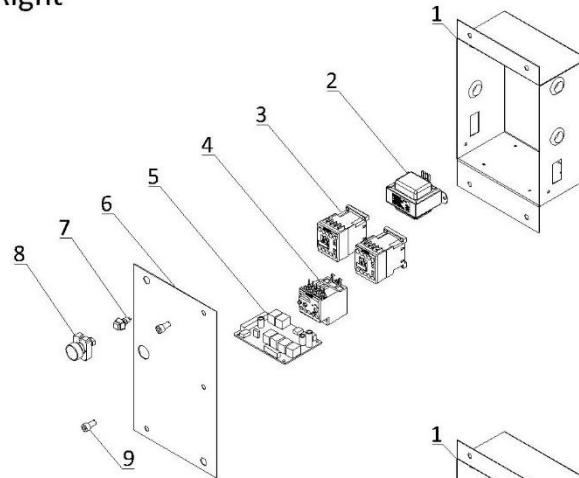

Left

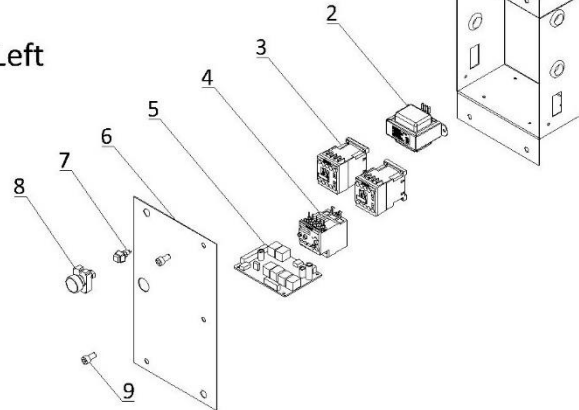

Ite	Part Number	Description	Qty.
1	2.2.4.17.0019	Electrical Box - 6795	2
2	3.1.01.04.007	Transformer - 50W - 50313MW-32	2
3	3.1.01.01.010	Contactors - 220V - 3RT6017-1AN21	4
4	3.1.01.02.010	Thermal Overload Relay - 3RU6116-1EBO	2
5	2.1.1.30.0012	Control Board - FB	2
6	2.2.4.20.0019	Cover - Electrical Box - 6795	2
7	3.1.03.04.003	Switch - FB - Low Mix Alarm - Green Square	2
8	3.1.03.04.002	Reset Button - Thermal Overload	2
9	3.6.11.041	Screw - M8x16	4