

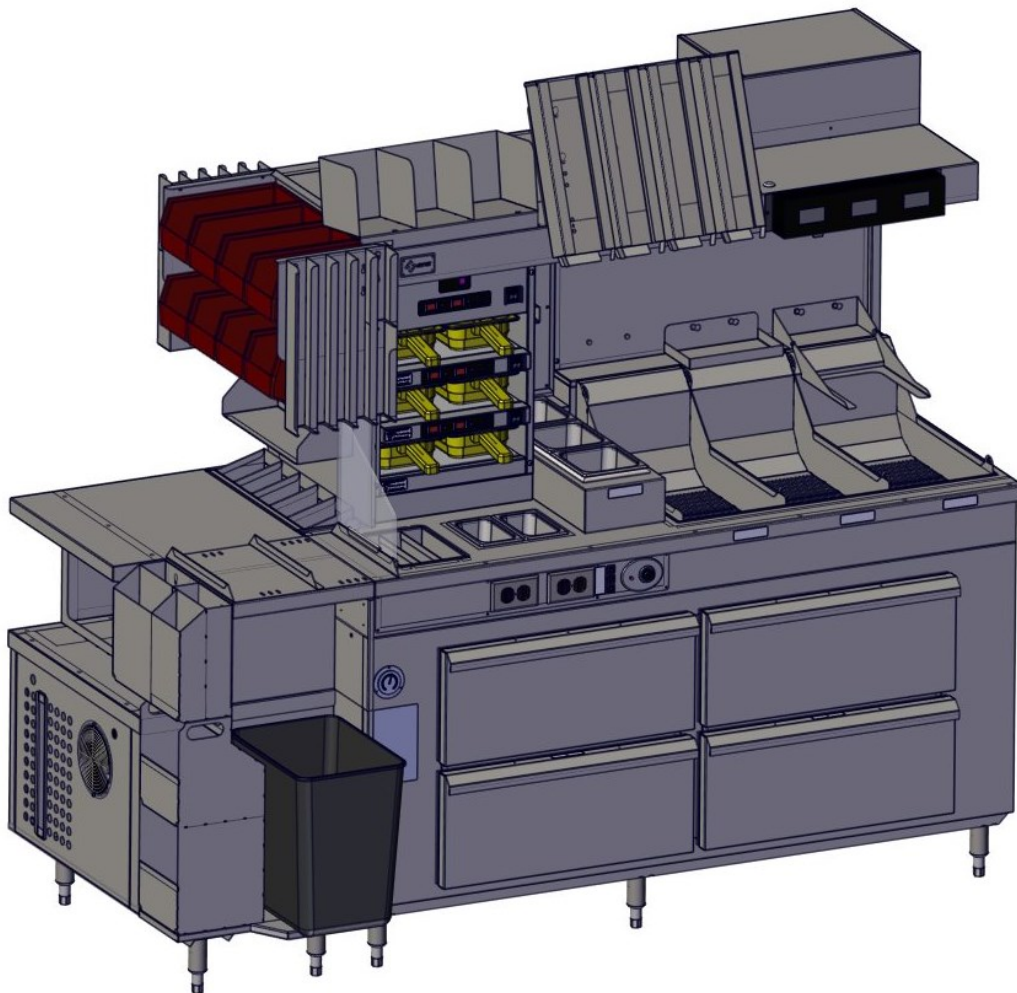

# Hot & Crisp Fry Station

MG3 Model E0703-FD018108



## Owner's Manual

(KEEP THIS MANUAL IN A SAFE PLACE AND RETAIN FOR FUTURE USE)

# FOR YOUR SAFETY



**DO NOT STORE OR USE GASOLINE OR OTHER FLAMMABLE VAPORS OR LIQUIDS IN THE VICINITY OF THIS OR ANY OTHER APPLIANCE.**



**WARNING: IMPROPER INSTALLATION, ADJUSTMENT, ALTERATION, OR MAINTENANCE CAN CAUSE INJURY OR DEATH. READ THE INSTALLATION, OPERATION AND MAINTENANCE INSTRUCTIONS THOROUGHLY BEFORE INSTALLING OR SERVICING THIS EQUIPMENT.**

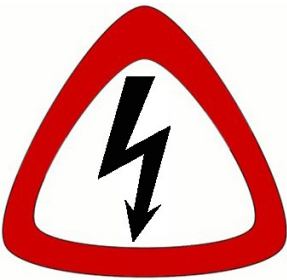

**WARNING SHOCK HAZARD: ALL SERVICE REQUIRING ACCESS TO NON-INSULATED ELECTRICAL COMPONENTS MUST BE PERFORMED BY A FACTORY AUTHORIZED TECHNICIAN**



**WARNING HOT SURFACES: EXPOSED SURFACES CAN BE HOT TO THE TOUCH AND MAY CAUSE BURNS ALLOW TIME FOR THE UNIT TO COOL DOWN BEFORE SERVICING**

**KEEP THIS MANUAL IN A SAFE**  
**PLACE AND RETAIN FOR FUTURE**  
**USE**



# TABLE OF CONTENTS



REPLACEMENT PART UNIT ASSIGNMENTS	5
REPLACEMENT PARTS FOR CONDENSING CABINET EXTERIOR	6-7
REPLACEMENT PARTS FOR DRAWER ASSEMBLY INSERT	8-9
REPLACEMENT PARTS FOR FRY HEATING & STAGING AREA	10-11
REPLACEMENT PARTS LIST	12
COMMON REFRIGERATION & HEATING PARTS	13-14
REFRIGERATION COMPONENTS DIAGRAM	15
QUICK START GUIDE	16-17
DAILY MAINTENANCE	18-21
WEEKLY MAINTENANCE	22
MONTHLY MAINTENANCE	23-25
PROGRAMMING GUIDE FOR TEMP. CONTROL UNIT	26-28
TEMPERATURE CONTROL ALARM CODES	29
TROUBLESHOOTING GUIDE	30-33
COMPONENT ACCESS GUIDE FOR SERVICE TECHS.	34-41
• CONDENSING CABINET	34
• LED LIGHTS AND TRANSFORMER	35
• FRY LANE HEATER INSERTS	36
• EVAPORATORS/EXPANSION VALVE	37-38
• HPM6 WARMER	39
ELECTRICAL REQUIREMENTS / WIRING SCHEMATICS	40-46
OVERALL DIMENSIONS	47
NOTES AND SERVICE LOG	48-52

# REPLACEMENT PART UNIT ASSIGNMENTS

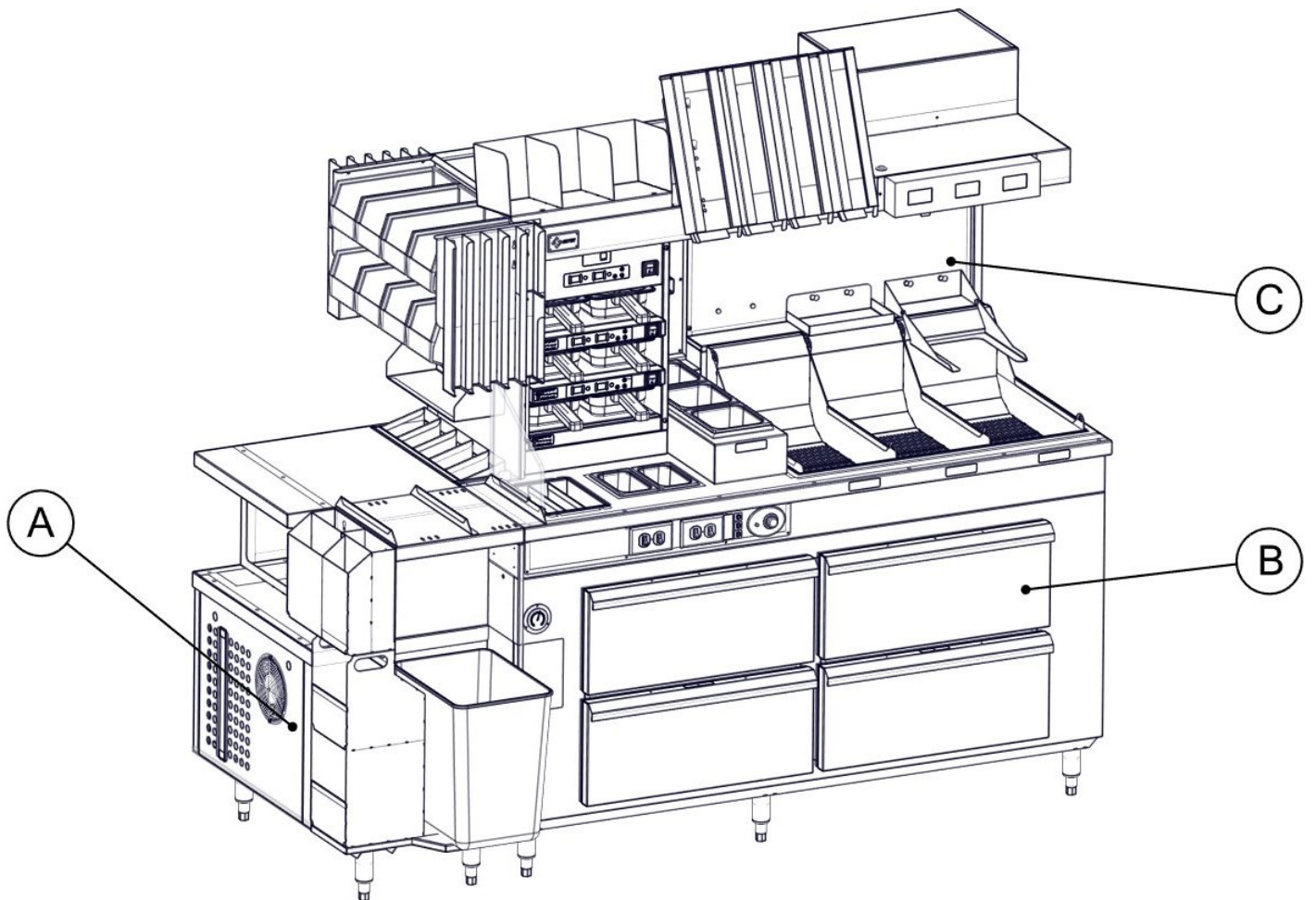

# REPLACEMENT PARTS FOR CONDENSING CABINET EXTERIOR

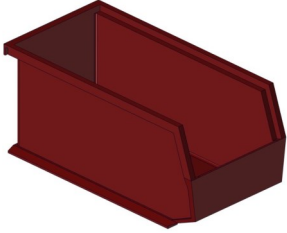
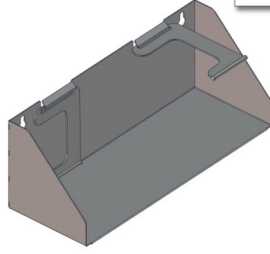
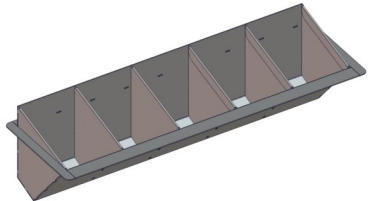
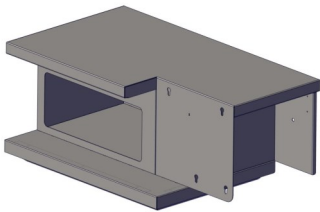
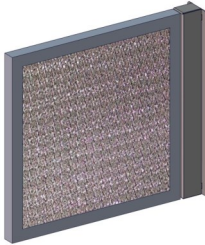
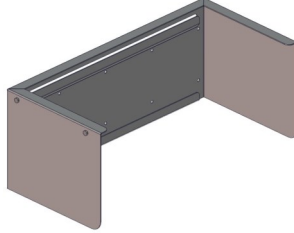
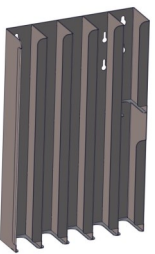
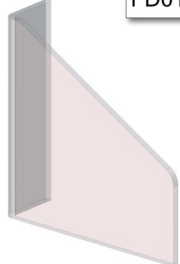
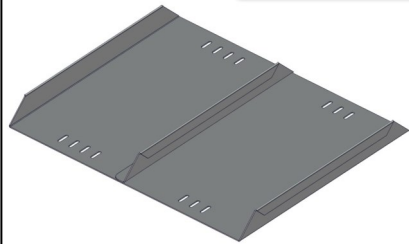
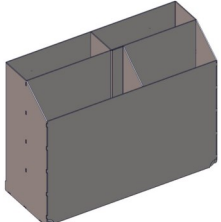
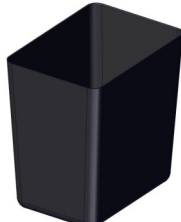
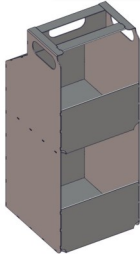
<p>Akro Bin 7000799 QTY-12</p>  <p><b>1</b></p>	<p>Napkin Holder FD018165 QTY-1</p>  <p><b>2</b></p>	<p>5 Compartment Condiment Holder FD018162 QTY-1</p>  <p><b>3</b></p>
<p>Prep Shelf FD018108-160 QTY-1</p>  <p><b>4</b></p>	<p>Condenser Fan Filter 7000732-13 QTY-1</p>  <p><b>5</b></p>	<p>Top Corner Akro Bin Bracket FD018167 QTY-1</p>  <p><b>6</b></p>
<p>5 Slot Nugget Sauce Dispenser FD018161-VALU6 QTY-2</p>  <p><b>7</b></p>	<p>3/8" Plexiglass Shield FD018129 QTY-1</p>  <p><b>8</b></p>	<p>2 Row Sandwich Slide FD018168 QTY-1</p>  <p><b>9</b></p>
<p>4 Compartment Bag Holder FD018163 QTY-1</p>  <p><b>10</b></p>	<p>Trash Bin 7000798-23BLK QTY-1</p>  <p><b>11</b></p>	<p>2 Compartment Kids Toy Holder FD018164 QTY-1</p>  <p><b>12</b></p>

# CONDENSING CABINET EXTERIOR REPLACEMENT PARTS DIAGRAM

(A)

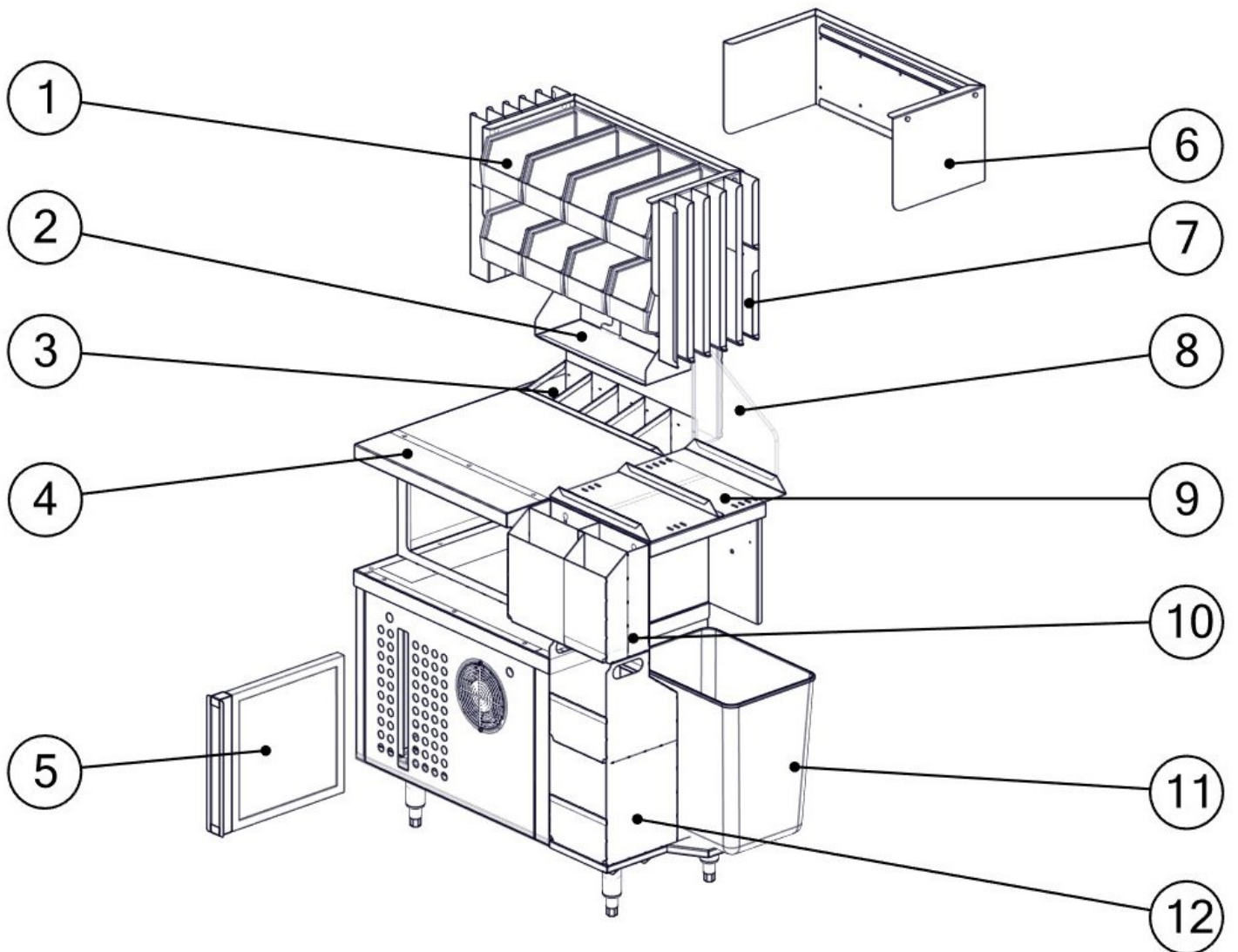

# REPLACEMENT PARTS FOR DRAWER

## ASSEMBLY INSERT

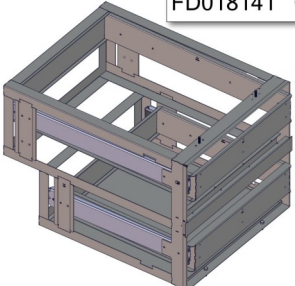
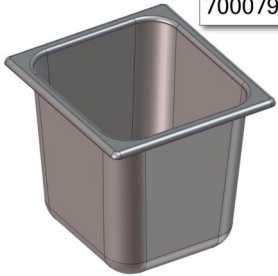
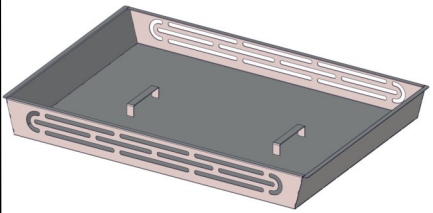
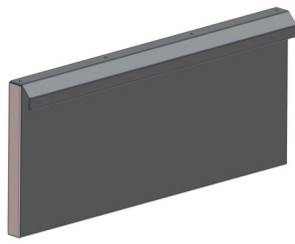
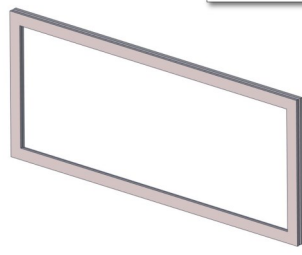
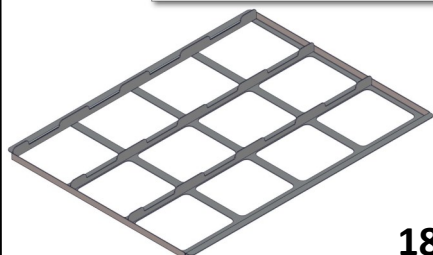
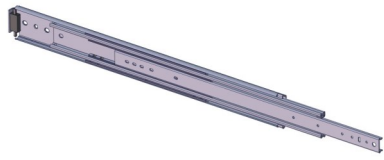
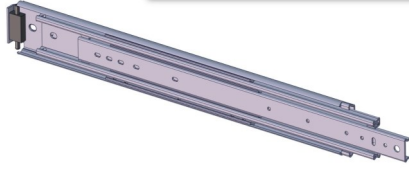
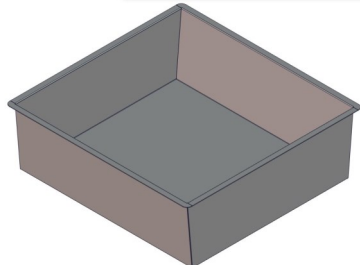
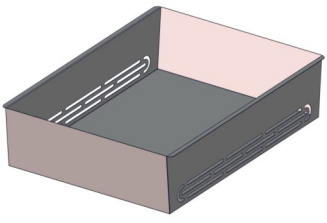



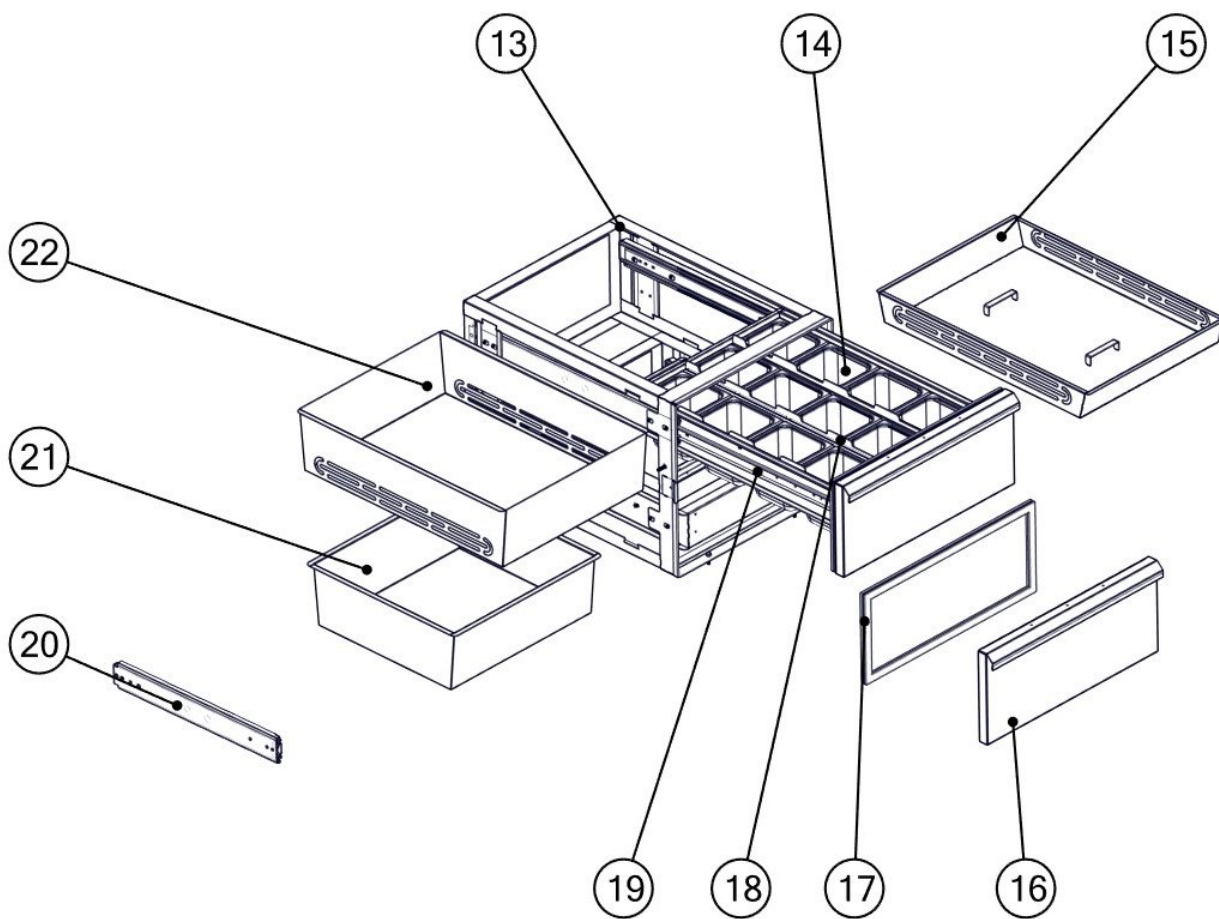

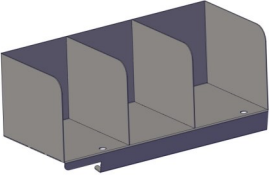
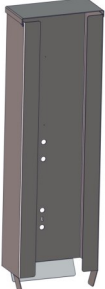

 <p>Drawer Assembly Insert FD018141 QTY-2</p> <p><b>13</b></p>	 <p>1/6th Size Pan 7000796 QTY-15</p> <p><b>14</b></p>	 <p>Fry Portioning Pan- Top Drawer FD018146 QTY-1</p> <p><b>15</b></p>
 <p>Drawer Front FD018141-DF QTY-4</p> <p><b>16</b></p>	 <p>Drawer Gasket 7000272-14 QTY-4</p> <p><b>17</b></p>	 <p>Pan Insert-(12) 1/6th Size Pans FD018142 QTY-1</p> <p><b>18</b></p>
 <p>28" Heavy Duty Drawer Slide 7000486-03320028 QTY-4 Top Drawer</p> <p><b>19</b></p>	 <p>22" Heavy Duty Drawer Slide 7000486-03320022 QTY-4 Bottom Drawer</p> <p><b>20</b></p>	 <p>Bulk Storage Pan-Bottom Drawer FD018144 QTY-2</p> <p><b>21</b></p>
	 <p>Bulk Storage Pan- Top Drawer FD018143 QTY-1</p> <p><b>22</b></p>	

# DRAWER ASSEMBLY INSERT REPLACEMENT PARTS DIAGRAM (B)

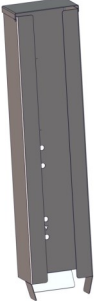

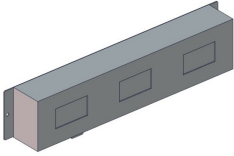
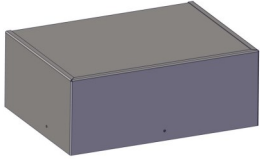
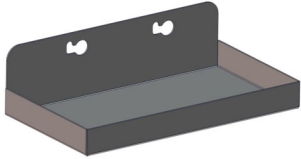
# REPLACEMENT PARTS FOR FRY HEATING AND STAGING AREA

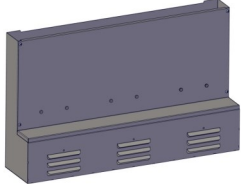
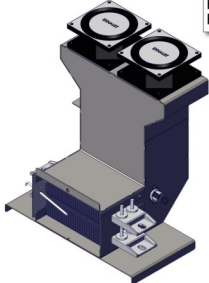
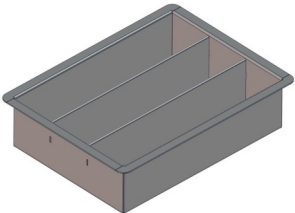

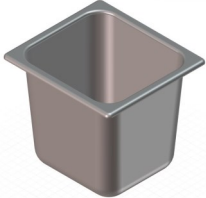
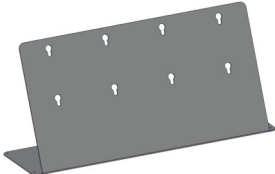
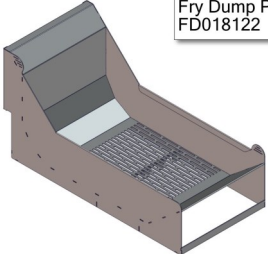
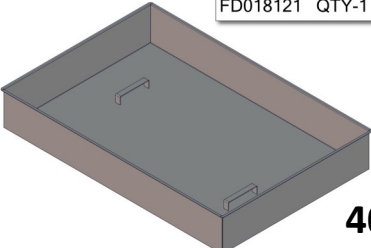
<p>Chili Cheese Fry Tray &amp; Lid Holder FD018127-3WIDE QTY-1</p>  <p><b>23</b></p>	<p>Fry Carton Dispenser - Large Size FD018126-L QTY-1</p>  <p><b>24</b></p>	<p>Fry Carton Dispenser- Small Size FD018126-S QTY-1</p>  <p><b>25</b></p>
<p>Fry Carton Dispenser- Value Size FD018126-V QTY-1</p>  <p><b>26</b></p>	<p>Fry Carton Dispenser- Medium Size FD018126-M QTY-1</p>  <p><b>27</b></p>	<p>Electrical Chase FD018130 QTY-1</p>  <p><b>28</b></p>
<p>Henny Penny Timer QTY-1</p>  <p><b>29</b></p>	<p>Fry Lane Heater Control Box FD018108-119 QTY-1</p>  <p><b>30</b></p>	<p>Fry Dump Double Salt Shelf FD018131 QTY-1</p>  <p><b>31</b></p>
<p>Nugget Holding Pan Bracket FD018132 QTY-1</p>  <p><b>32</b></p>	<p>Fry Lane Heater Box FD018108-123 QTY-1</p>  <p><b>33</b></p>	<p>Fry Lane Heater Insert FD018108-124 QTY-3</p>  <p><b>34</b></p>
<p>3 Row Fry Staging Ribbon FD018128 QTY-1</p>  <p><b>35</b></p>	<p>1/9 th Size Pan 7000797 QTY-2</p>  <p><b>36</b></p>	<p>1/6 th Size Pan 7000796 QTY-15</p>  <p><b>37</b></p>
<p>Fry Carton Bracket FD018125 QTY-1</p>  <p><b>38</b></p>	<p>Fry Dump Pan FD018122 QTY-3</p>  <p><b>39</b></p>	<p>Fry Lane Holding Pan FD018121 QTY-1</p>  <p><b>40</b></p>

# FRY HEATING & STAGING AREA REPLACEMENT PARTS DIAGRAM

(C)

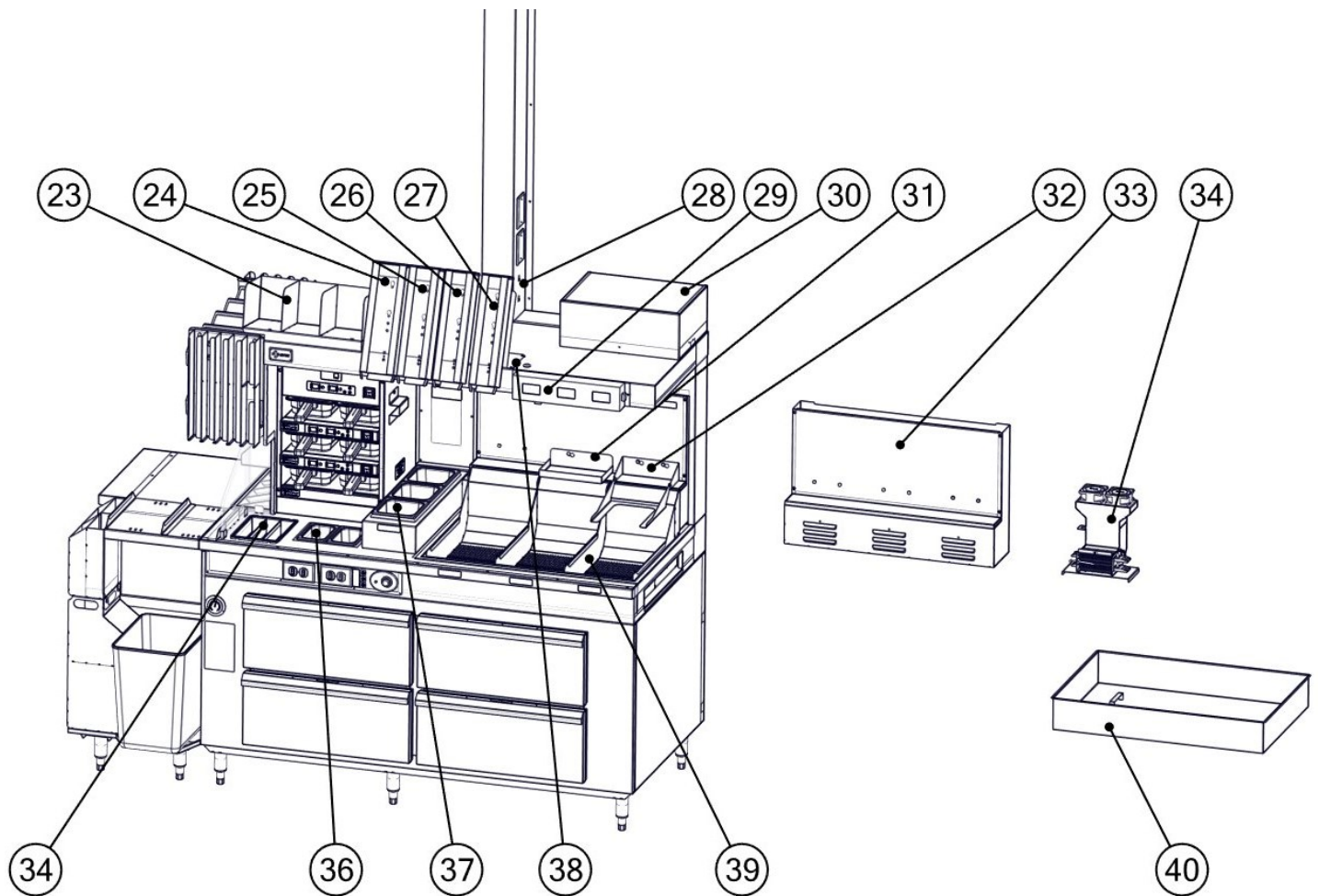



# PARTS LIST FOR UNITS A,B,C

ID#	NAME	PART#	QTY	UNIT ID
1	AKRO BIN	7000799	12	A
2	NAPKIN HOLDER	FD018165	1	A
3	5 COMPARTMENT CONDIMENT HOLDER	FD018162	1	A
4	PREP SHELF	FD018108-160	1	A
5	CONDENSER FAN FILTER	7000732-13	1	A
6	TOP CORNER AKRO BIN BRACKET	FD018167	1	A
7	5 SLOT NUGGET SAUCE DISPENSER	FD018161	2	A
8	3/8" PLEXIGLASS SHIELD	FD018129	1	A
9	2 ROW SANDWICH SLIDER	FD018168	1	A
10	4 COMPARTMENT BAG HOLDER	FD018163	1	A
11	TRASH BIN	700798-23BLK	1	A
12	KIDS TOY HOLDER	FD018164	1	A
13	DRAWER ASSEMBLY INSERT	FD018141	2	B
14	1/6TH SIZE PAN	7000796	15	B
15	FRY PORTIONING PAN-TOP DRAWER	FD018146	1	B
16	DRAWER FRONT	FD018141-DF	4	B
17	DRAWER GASKET	7000272-14	4	B
18	PAN INSERT FOR 12 1/6TH SIZE PANS	FD018142	1	B
19	28" HEAVY DUTY DRAWER SLIDE-TOP DRAWER	7000486-03320028	4	B
20	22" HEAVY DUTY DRAWER SLIDE-BOTTOM DRAWER	7000486-03320022	4	B
21	BULK STORAGE PAN-BOTTOM DRAWER	FD018144	2	B
22	BULK STORAGE PAN-TOP DRAWER	FD018143	1	B
23	CHILI CHEESE FRY TRAY AND LID HOLDER	FD018127-WIDE	1	C
24	FRY CARTON DISPENSER-LARGE SIZE	FD018126-L	1	C
25	FRY CARTON DISPENSER-MEDIUM SIZE	FD018126-M	1	C
26	FRY CARTON DISPENSER-SMALL SIZE	FD018126-S	1	C
27	FRY CARTON DISPENSER-VALUE SIZE	FD018126-V	1	C
28	ELECTRICAL CHASE	FD018130	1	C
29	HENNY PENNY TIMER	FD018188	1	C
30	FRY LANE HEATER CONTROL BOX	FD018108-119	1	C
31	FRY DUMP DOUBLE SALT SHELF	FD018131	1	C
32	NUGGET HOLDING PAN BRACKET	FD018132	1	C
33	FRY LANE HEATER BOX	FD018108-123	1	C
34	FRY LANE HEATER INSERT	FD018108-124	3	C
35	3 ROW FRY STAGING RIBBON	FD018128	1	C
36	1/9TH SIZE PAN	7000797	2	C
37	1/6TH SIZE PAN	7000796	15	C
38	FRY CARTON BRACKET	FD018125	1	C
39	FRY DUMP PAN	FD018122	3	C
40	FRY LANE HOLDING PAN	FD018121	1	C

# COMMON REFRIGERATION & HEATING PARTS

Sofasco Axial Fan  
Model #: sA17251V1MBT  
7000328-6 QTY-1



1

Copeland Condensing Unit 1/2 hp  
Model #: M4FL-H051-IAA-272  
7000568-H051 QTY-1

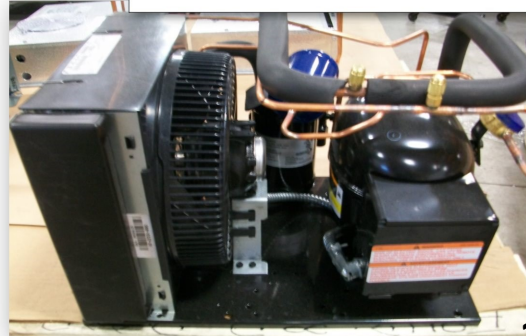

2

Johnson Controls Dual Pressure Control  
Model #: P70MA-1  
7000016 QTY-1



3

Carlo Gavazzi Contactor  
Model #: GDP251S  
7000976 QTY-1



4

Sporlan Temp. Control  
Model #: PSK204N9  
7000977 QTY-1



5

Component Hardware  
Condensate Evap. Pan  
Model #: T12-5000  
7000023-72 QTY- 2



6

# COMMON REFRIGERATION & HEATING PARTS

Distributer Valve  
7000823 QTY-1



7

Sporlan Expansion Valve  
Model #: 109933  
7000111 QTY-1

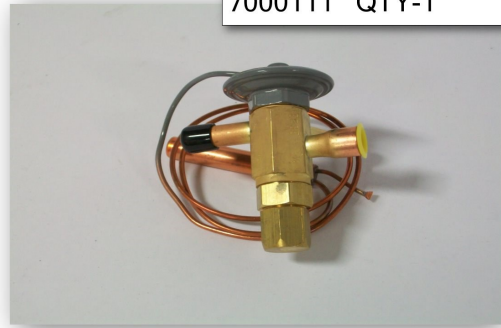

8

Heatcraft Evaporator Coil  
Model #: BBL10AG  
7000048-No Bracket QTY-2



9

Evaporator Drain Pan  
7000023 QTY-2



10

Drain Heater  
7000733 QTY-2



11

# REFRIGERATION COMPONENTS DIAGRAM

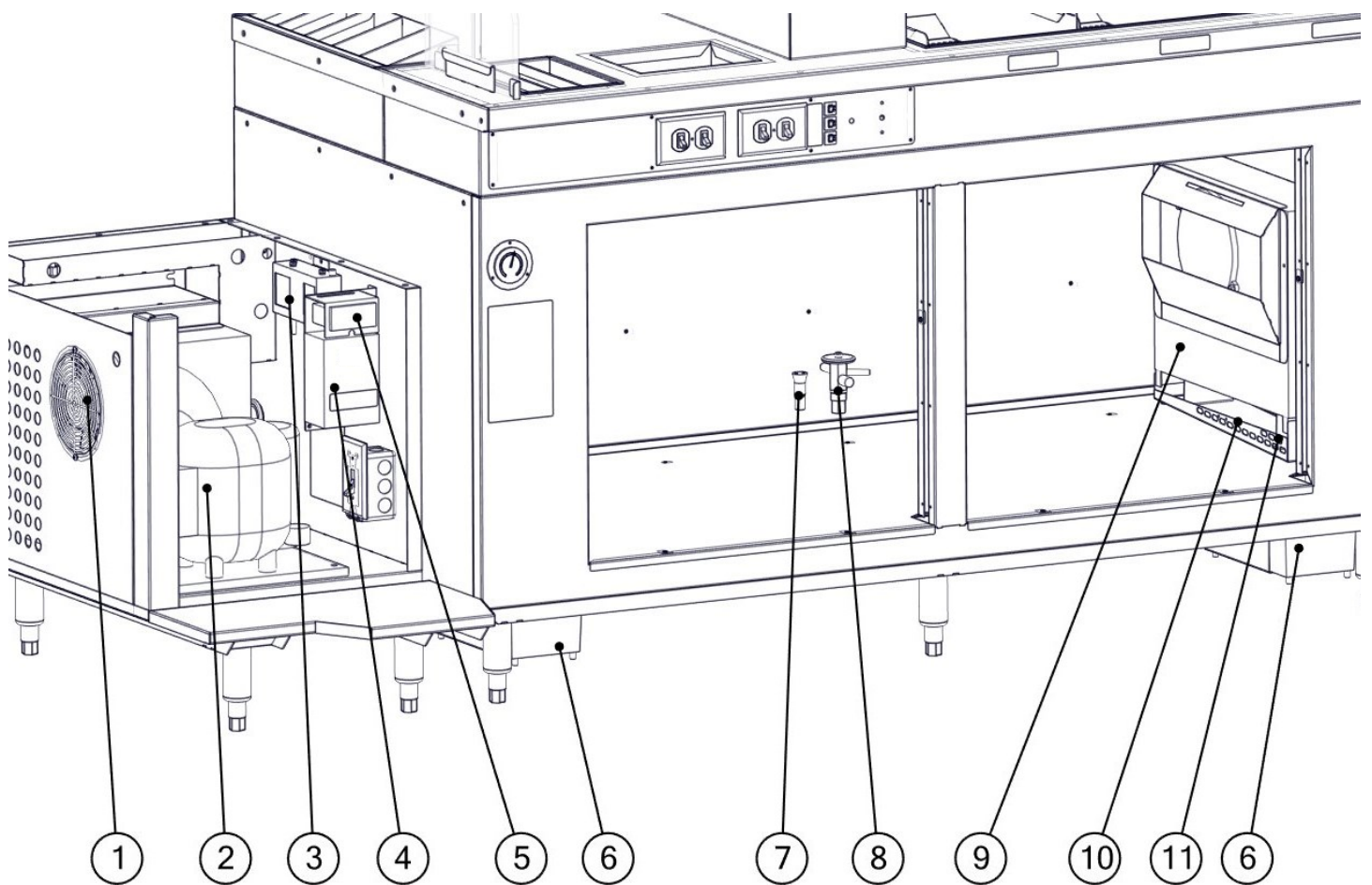

## QUICK START GUIDE FOR OPENING MANAGERS

1. Turn on all switches in the front of the unit “on” this will activate the 3 heaters, the LED lights and the Henny Penny timer.

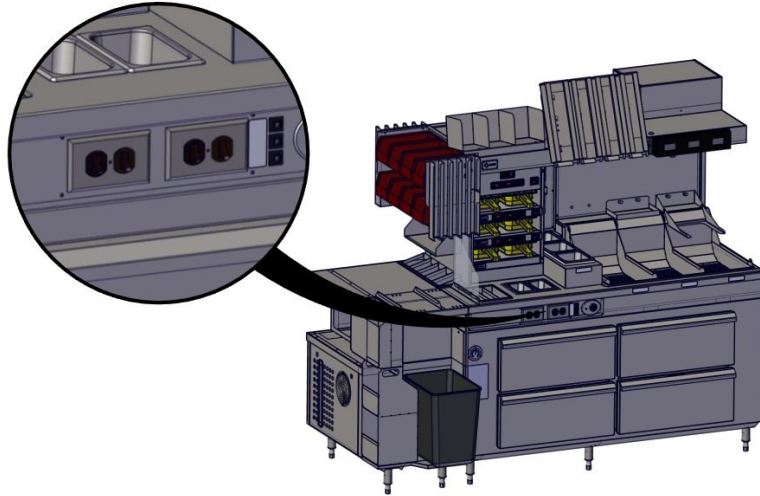

If the Henny Penny timer does not turn on check the on/off switch on the right side of the timer.



2. Set the Henny Penny timer for the appropriate mode by pressing and holding the timer button next to any display for 15 seconds. When done correctly the left display will read “SLCT” and show up in green. The middle display will show the currently set menu. Finally the right display will read “EXIT” and show up in red.



3. Using the middle timer button, press until desired menu mode shows in the middle display.



# QUICK START GUIDE FOR OPENING MANAGERS

Below are the three available settings for the Henny Penny timer.

## BREAKFAST



## LUNCH



## DUAL-SERVE



3. Press the timer button next to the left display reading "SLCT" to confirm your menu mode option.



4. Once the appropriate menu mode has been selected press and hold the right timer button next to the "EXIT" display for 10 seconds. This will end set up mode and the Henny Penny timer is ready for use.



## NOTE:

**Henny Penny Timer model #: TLT-3**

**Henny Penny Tech support #: 1-800-417-8405**

## DAILY MAINTENANCE HOT & CRISP FRY STATION

1. Turn off the unit using the four brown switches in the front to allow unit to cool down and avoid any electrical shock..

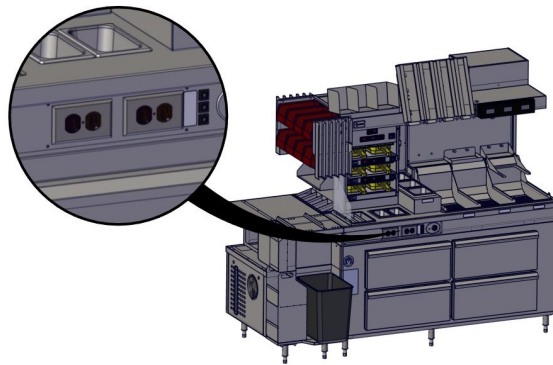

2. Turn off the WELLS HMP-6 food warmer and allow time to cool.
3. Once the fry station has had time to cool down, remove the Double Salt Shelf, Nugget Holding Pan Bracket and Fry Dump Pans (3) for cleaning.

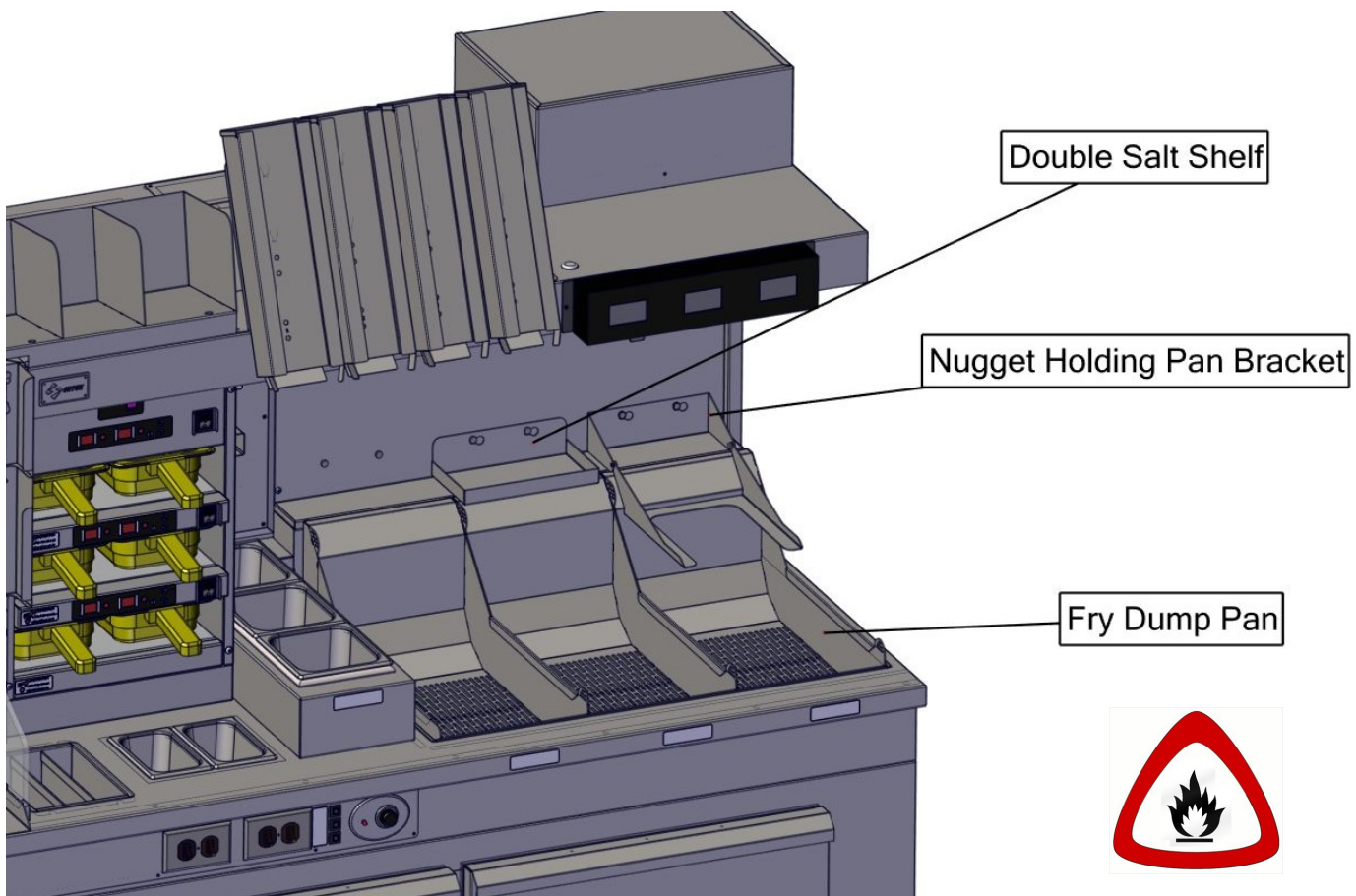

## DAILY MAINTENANCE HOT & CRISP FRY STATION

4. Remove the Fry Lane Holding Pan for cleaning.
5. Once both the Fry Dump Pans (3) and Fry Lane Holding Pan are removed clean area of all debris using a damp cloth and Wendy's approved cleaning agent.

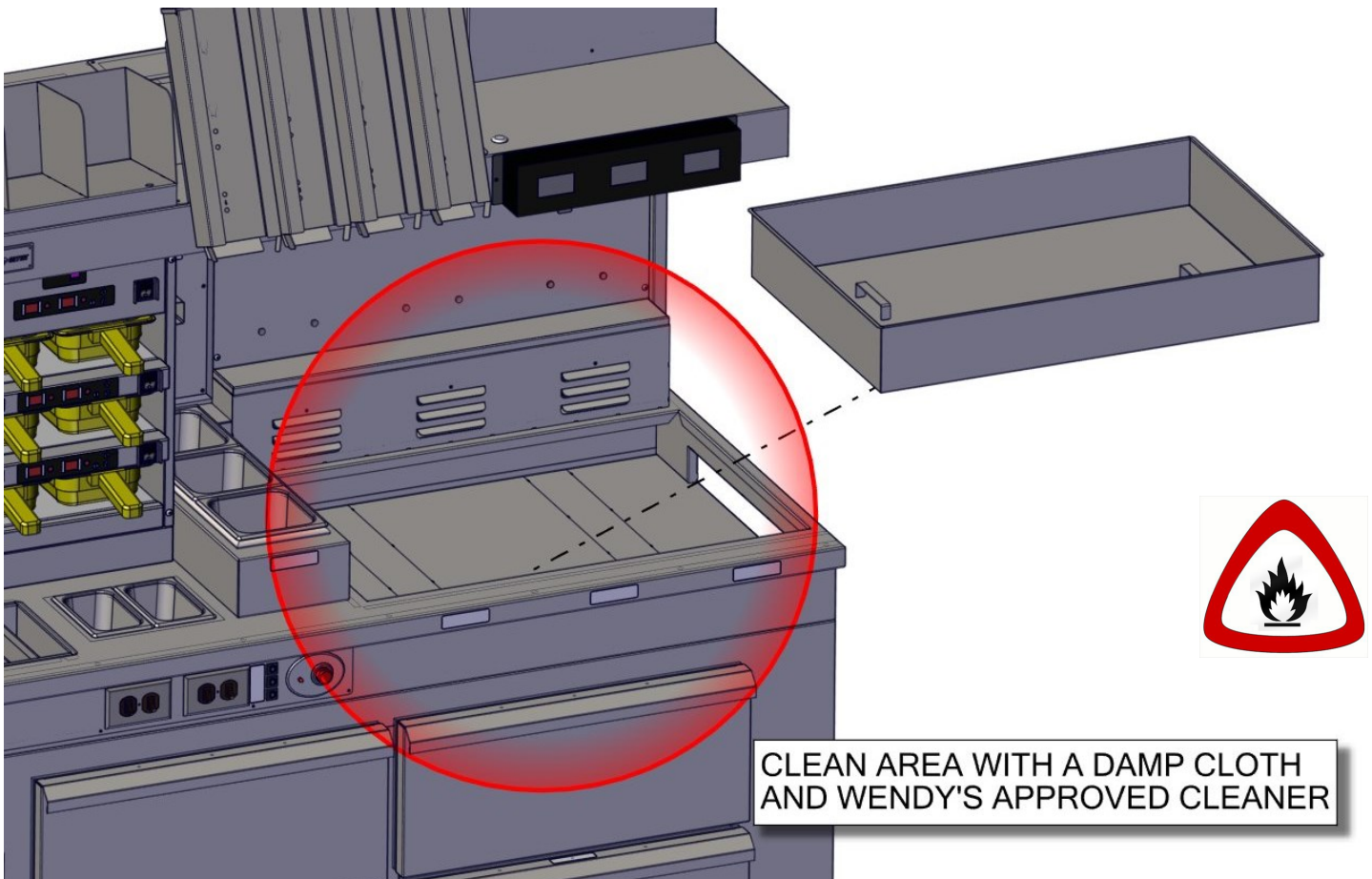

## DAILY MAINTENANCE HOT & CRISP FRY STATION

6. Remove the 3 Row Fry Staging Ribbon, Nugget Tong Holder, and (2) 1/9 Size Pans for daily cleaning.
7. Remove the (12) 1/6th size pans from the portioning drawer for cleaning.
8. After the wells HMP6 food warmer has cooled down remove the (3) 1/6 Size Pans for cleaning. Remove any remaining water and any food debris from the well.

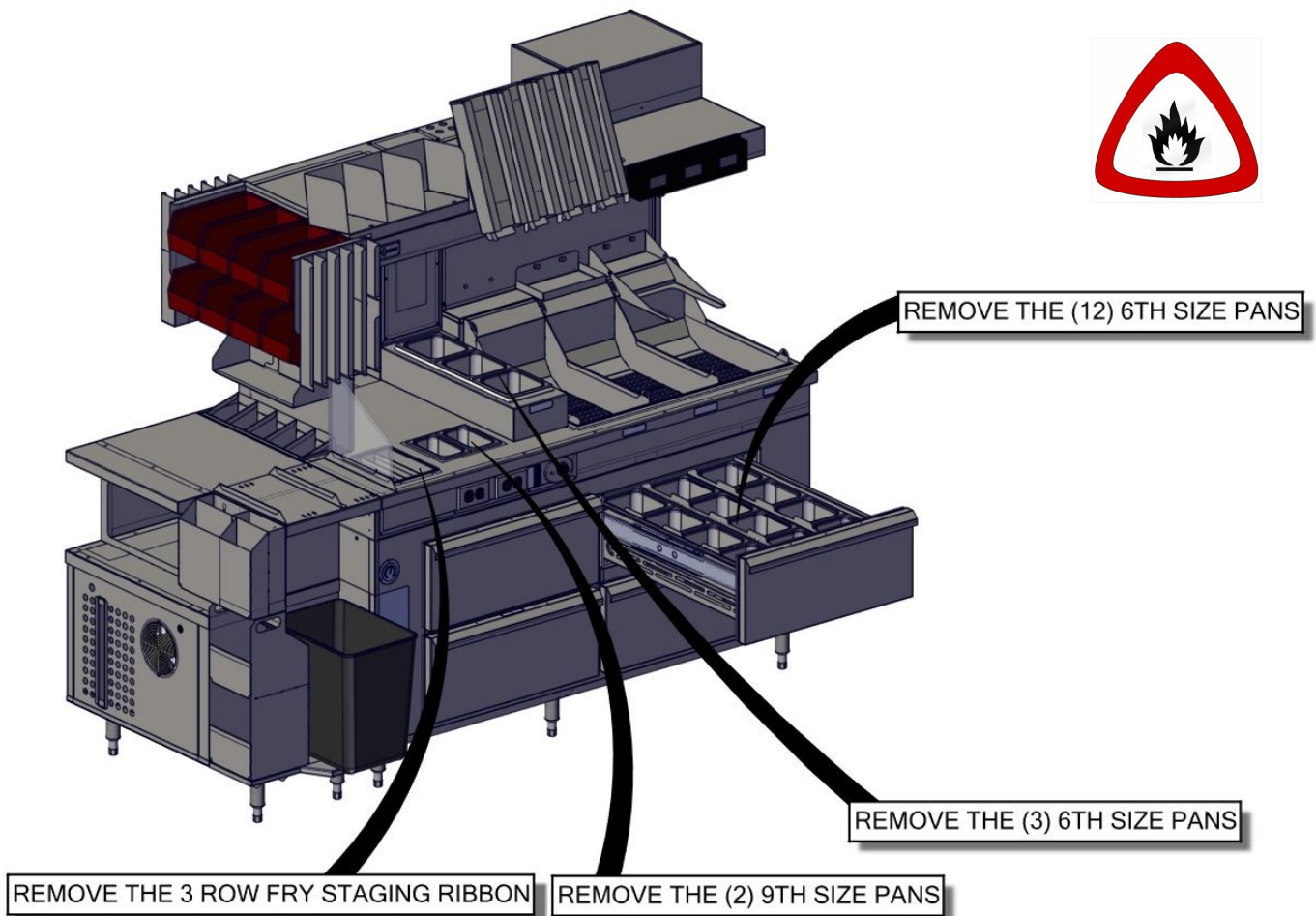

## DAILY MAINTENANCE HOT & CRISP FRY STATION

9. Clean out bottom of cheese holding area.
10. Make sure there are no obstructions blocking the air intake axial fan by the condensing unit on the side.
11. Make sure all drawer gaskets are in good repair.
12. Wipe down the entire unit with a damp cleaning towel using a Wendy's approved cleaner.
13. Evaluate the unit to make sure everything is working and no parts are missing.

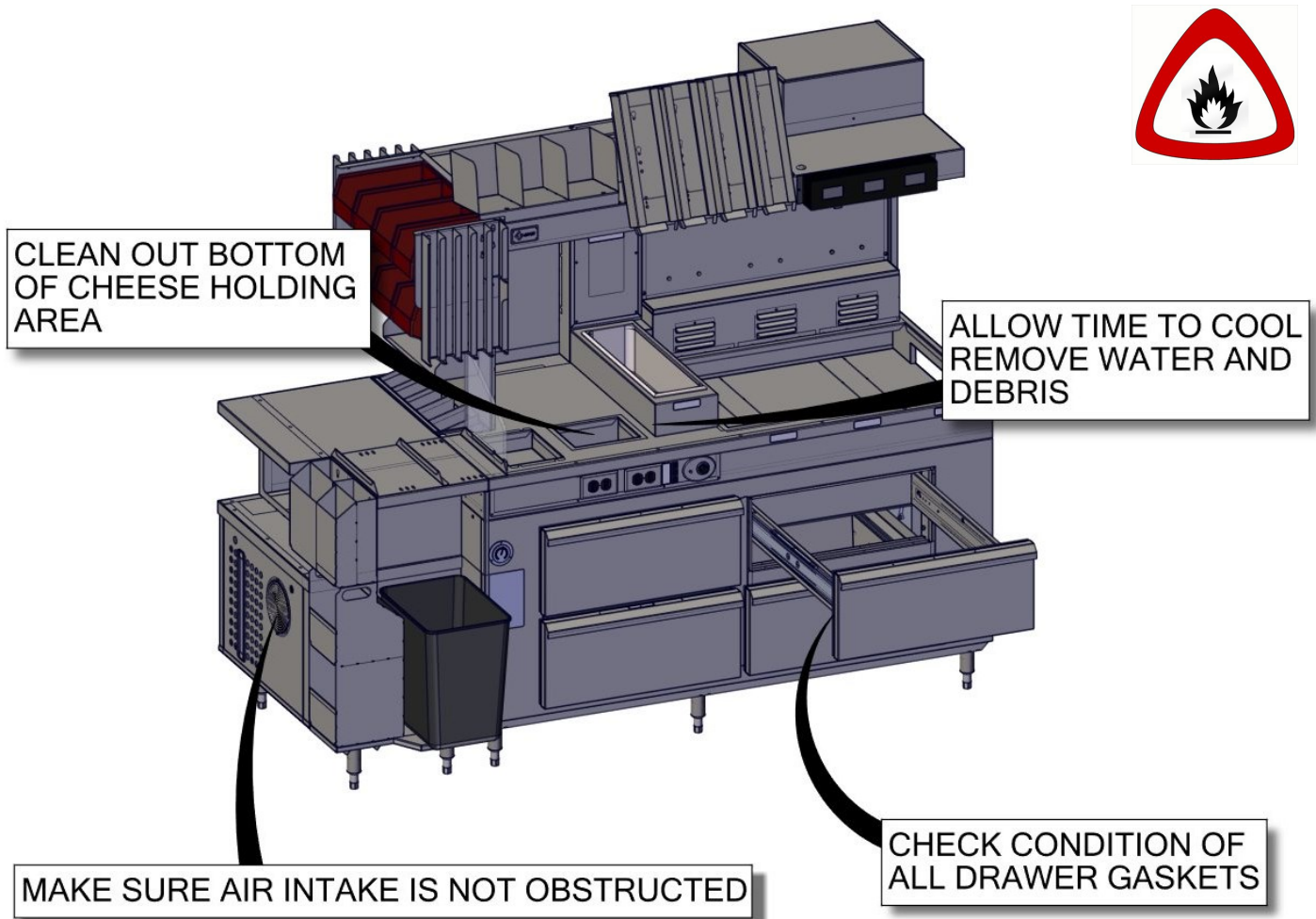

## WEEKLY MAINTENANCE HOT & CRISP FRY STATION

1. Perform daily maintenance .
2. Remove and clean condenser fan filter.
3. Remove all debris from drawer gaskets.

REMOVE AND CLEAN  
CONDENSER FAN  
FILTER

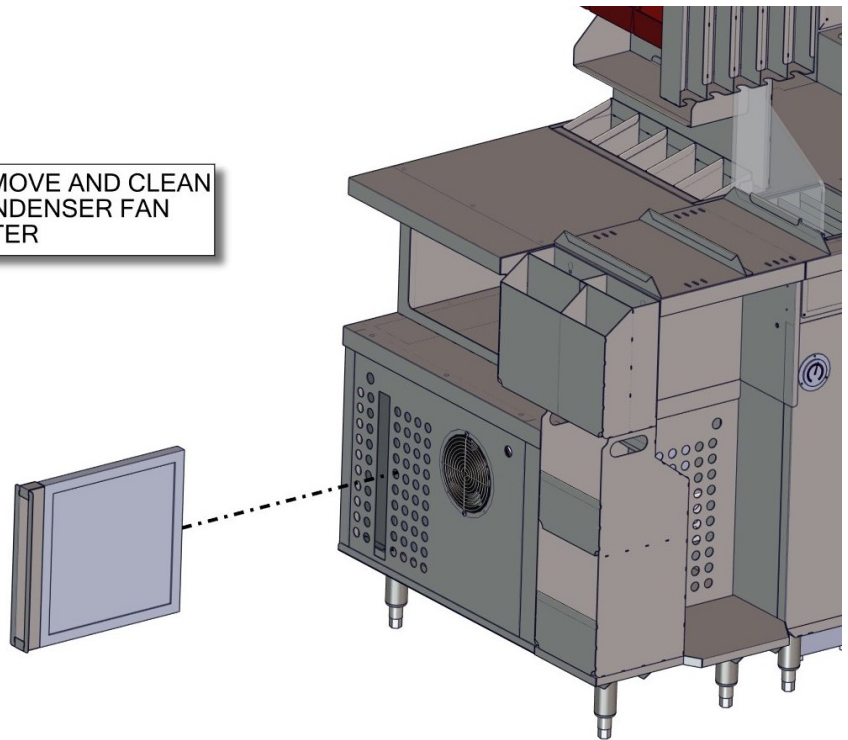

REMOVE ALL DEBRIS FROM DRAWER GASKETS

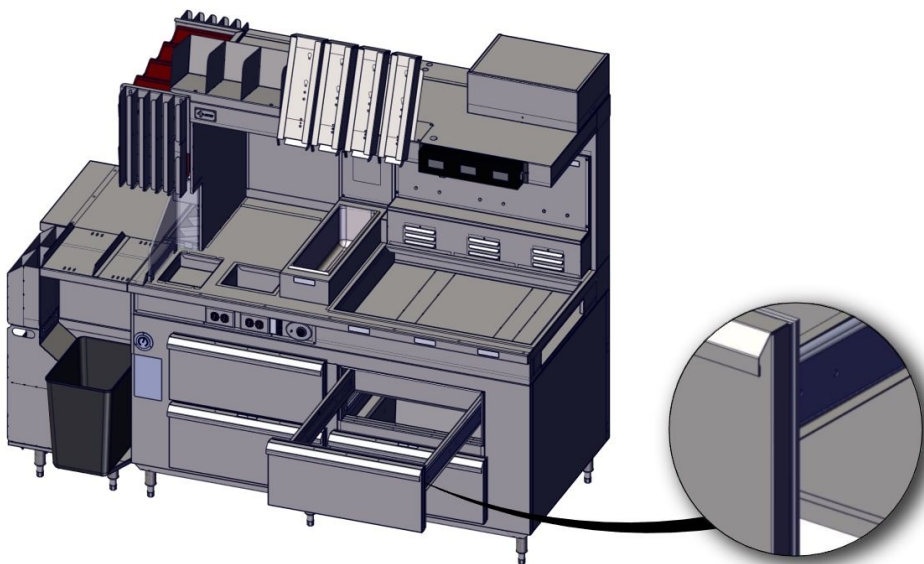

# MONTHLY MAINTENANCE HOT & CRISP FRY STATION



1. Perform daily maintenance.
2. Perform weekly maintenance.
3. Clean condensing unit coil.
  - I. First you must remove the panel located on the back of the unit's condenser cabinet **MAKE SURE THE UNIT IS OFF** If there is no access to the back panel in the first figure refer to the next page.

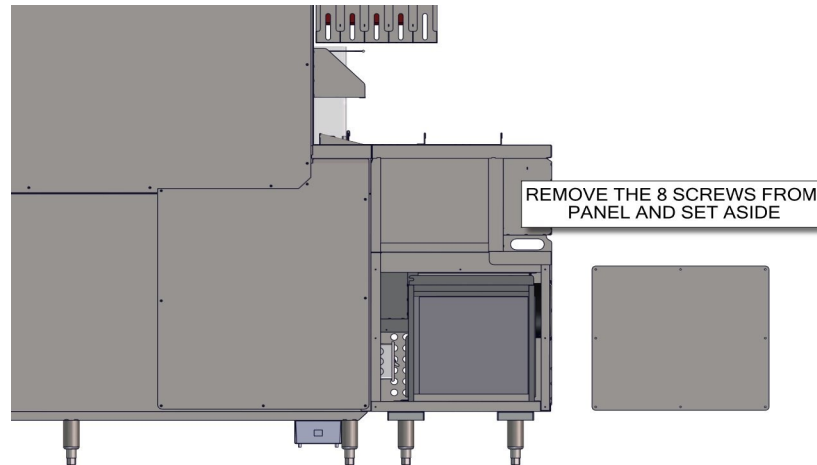

- II. Next remove the Condenser fan filter and filter bracket.

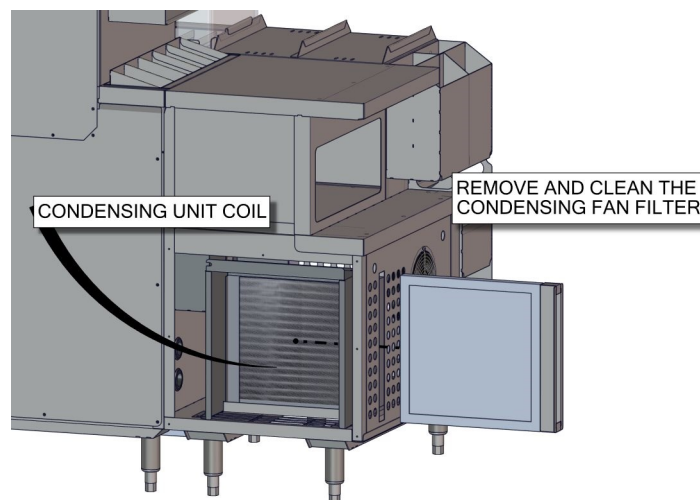

- III. Clean the condensing unit coil with a Wendy's approved cleaning agent.

# MONTHLY MAINTENANCE HOT & CRISP FRY STATION

- IV. Remove the condenser fan filter and set aside for cleaning. Next remove the side panel from the condenser cabinet and set aside. **BE MINDFUL OF THE FAN'S WIRING.**

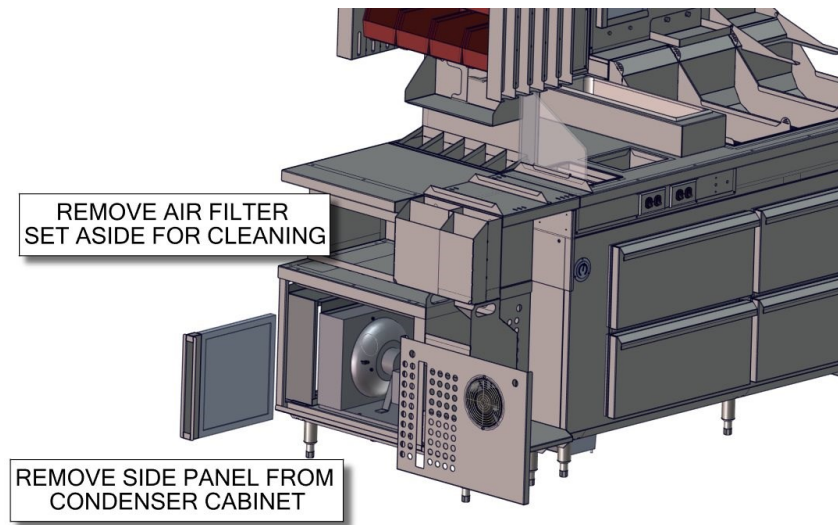

- V. There is one screw holding the Condenser Filter Bracket in place, remove the 1/4" hex head screw so that the bracket can be removed.

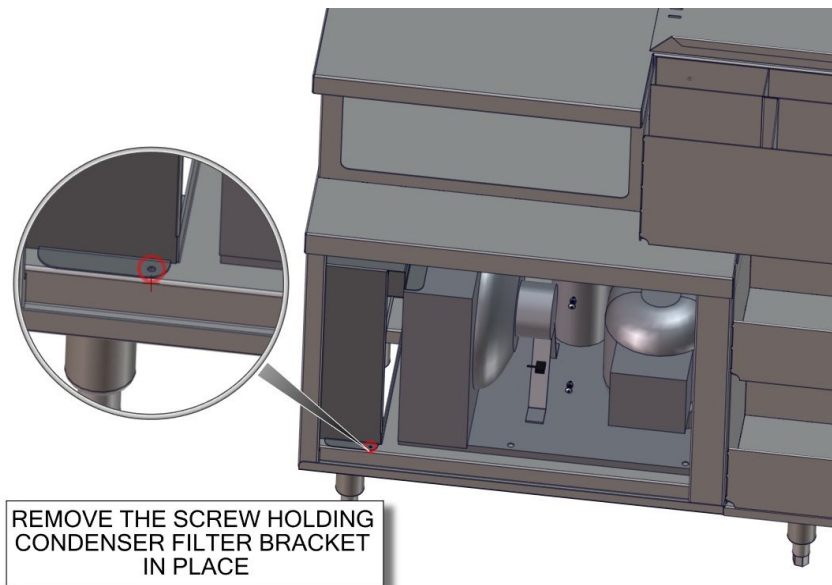

## MONTHLY MAINTENANCE HOT & CRISP FRY STATION

VI. Remove the Air Filter Bracket and set aside.

VII. Clean the condensing coil with a soft brush.

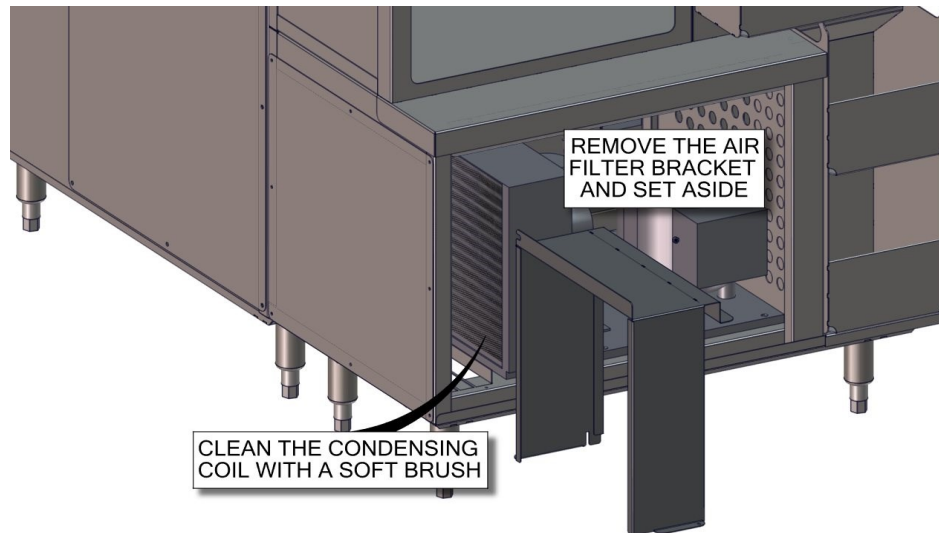

4. Clean any debris in the Drawer Slide Tracks.

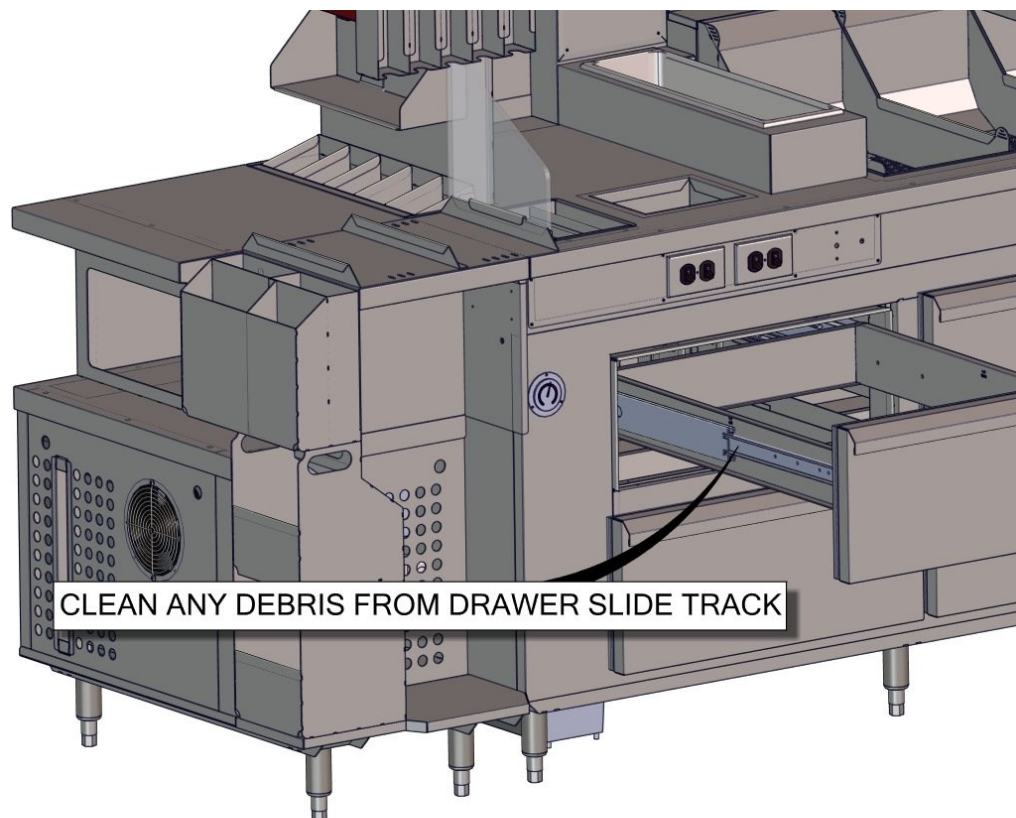

# SPORLAN PSK204N9 QUICK REFERENCE PROGRAMMING GUIDE:

## FREEZER SETTINGS **FD018108**

### Programming the Control

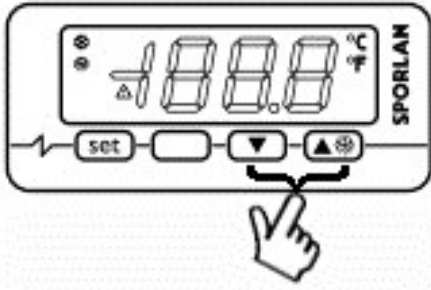

1. Press and hold both arrow buttons simultaneously for 4 seconds if done correctly the display will read "PA".

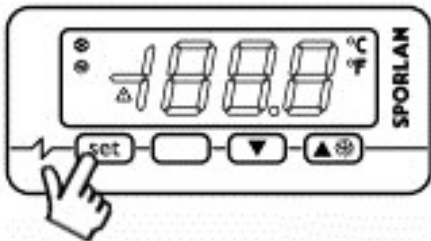

2. Press set the display should read "0"

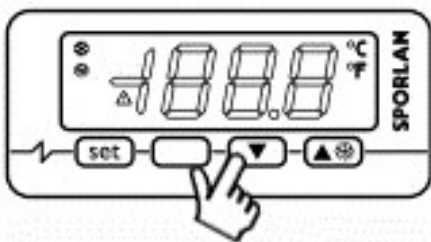

3. Use the down arrow to adjust the value to "-19"

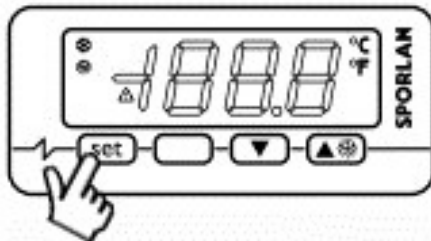

4. Press set

Continued on next page

## Programming the Control

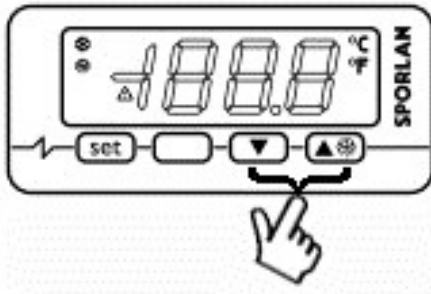

5. Press and hold both arrow buttons simultaneously for 4 seconds if done correctly the display will read “SP”.

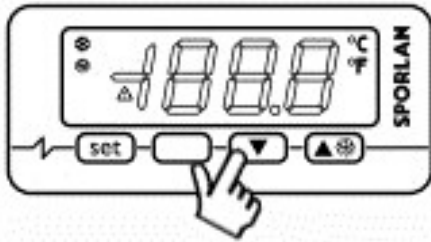

6. Use the arrow keys to cycle through the different parameter groups.

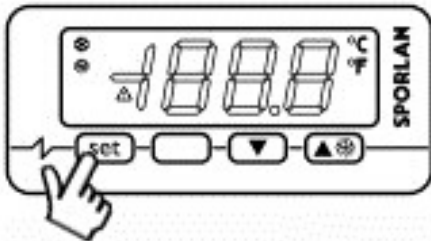

7. Once the desired parameter is found press the “set” button enter the parameter’s value.

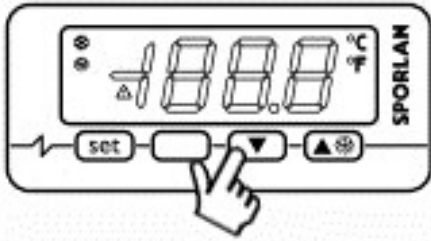

8. Use the arrow keys to adjust the value of the parameter.

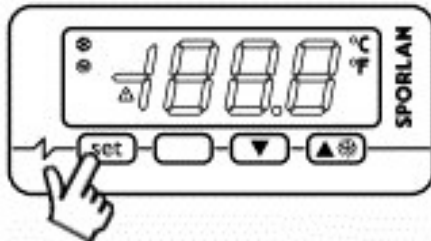

9. Once the proper value has been found press “set” to confirm the new setting.

Continued on next page

## Programming the Control

The Parameters shown below need to be changed from factory defaults. The “SP” or set point parameter shown in yellow below should be set last to avoid any Celsius to Fahrenheit conversion issues. NOTE: **these are FD018108 freezer settings!**

SETTING	DISPLAY CODE
7*	SP
1*	P2
2*	P3
0*	P4
0*	r1
15*	r2
0*	C1

SETTING	DISPLAY CODE
1*	C2
0*	C10
5*	d0
55° F*	d2
35*	d3
8*	d7
0*	A2

SETTING	DISPLAY CODE
40*	A4
0*	A5
3*	F0
35*	F1
1*	F3
0*	L0
1*	L5
7*	U1

### Changing the set point

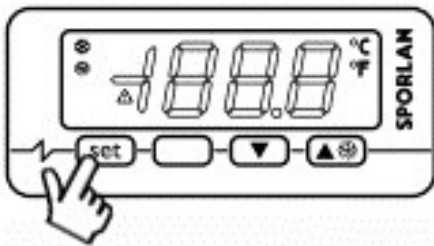

1. Press and hold “set” until the set point is displayed.

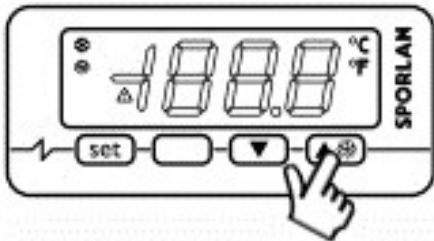

2. Press up or down to adjust the set point value. (The set point should be set for 7°f.)

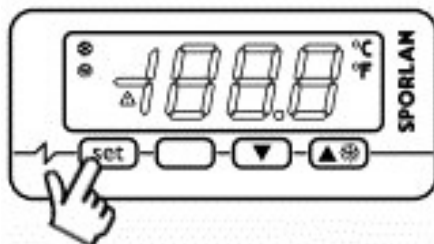

3. Once the desired set point is found press “set” or do not push any buttons for 15 seconds, the unit will return to normal operation.

## Temperature Control Alarm and Fault Display Codes

Display Code	Meaning	Remedies
AL	Minimum temperature alarm.	<ul style="list-style-type: none"> <li>• Check alarm temperature</li> <li>• Check parameters A0,A1, and A2, ensure they are at the proper setting.</li> </ul>
AH	Maximum temperature alarm	<ul style="list-style-type: none"> <li>• Check alarm temperature</li> <li>• Check parameters A3, A4, and A5, ensure they are at the proper setting.</li> </ul>
iD	Microport input alarm	<ul style="list-style-type: none"> <li>• Check the causes which activated the input.</li> <li>• Check parameters i0, i1, and i4.</li> <li>• Effects of alarm can be disabled by setting parameter i0 to "0".</li> </ul>
PF	Power failure alarm	<ul style="list-style-type: none"> <li>• Turn the unit off and back on after approximately 3 minutes.</li> </ul>
iA	Multipurpose input alarm	<ul style="list-style-type: none"> <li>• Check the condition and connections of the defrost heaters this alarm may signal a dysfunctional defrost heater.</li> </ul>
iSd	Device blocked alarm (only if parameter P4 is set to 3)	<ul style="list-style-type: none"> <li>• Check the causes which activated the input.</li> <li>• Check parameters i5, i6,i7,i8, and i9.</li> </ul>
COH	Condenser overheating alarm	<ul style="list-style-type: none"> <li>• Turn the unit off and back on after approximately 3 minutes.</li> </ul>
CSd	Compressor blocked alarm	<ul style="list-style-type: none"> <li>• Turn the unit off and back on after approximately 3 minutes.</li> </ul>
Pr1	Cabinet probe error	<ul style="list-style-type: none"> <li>• Check connections on the probe</li> </ul>
Pr2	Evaporator probe error	<ul style="list-style-type: none"> <li>• Check connections on the probe</li> </ul>
Pr3	Auxiliary probe error	<ul style="list-style-type: none"> <li>• Set parameter P4 to "0"</li> </ul>
Rtc	Clock error	<ul style="list-style-type: none"> <li>• Reset the unit's date and time (this alarm does not effect the operation of the unit"</li> </ul>

## TROUBLESHOOTING GUIDE (TOTAL STATION & WARMER)

PROBLEM	POSSIBLE CAUSE	SOLUTION
<p><b>UNIT WILL NOT RUN</b></p>	<ul style="list-style-type: none"> <li>• Breakers could be turned off</li> <li>• Partial electrical power to building</li> </ul>	<ul style="list-style-type: none"> <li>• Turn breakers off and back on to see if unit comes on.</li> <li>• Check to make sure other equipment is working. If so and the fry station is not running call the Sertek service line (877-277-7221).</li> <li>• If you are experiencing problems with other equipment as well call your maintenance provider.</li> </ul>
<p><b>FRIES NOT STAYING WARM</b></p>	<ul style="list-style-type: none"> <li>• Breakers could be turned off</li> <li>• On/Off switches for heating lanes not turned on</li> </ul>	<ul style="list-style-type: none"> <li>• Turn breakers off and back on to see if unit comes on.</li> <li>• Check to make sure that the on/off switches located at the front left side of the station are on.</li> <li>• If breakers and on off switch are both on, and the unit is still not running call the Sertekservice line.</li> </ul>
<p><b>AN INDIVIDUAL FRY LANE OF THE FRY DUMP HEATER IS BLOWING AIR AND NOT KEEPING FRIES WARM</b></p>	<ul style="list-style-type: none"> <li>• Heating unit not working properly</li> </ul>	<ul style="list-style-type: none"> <li>• Allow time (15 minutes) for warmer to heat up, after 15 minutes if there is no hot air blowing at this time call the Sertek service line.</li> </ul>

## TROUBLESHOOTING GUIDE (TOTAL STATION & WARMER)

PROBLEM	POSSIBLE CAUSE	SOLUTION
<p><b>AN INDIVIDUAL FRY LANE OF THE FRY DUMP HEATER IS NOT BLOWING ANY AIR OR HEATING UP</b></p>	<ul style="list-style-type: none"> <li>• Heating unit not working</li> <li>• On/Off switches turned off</li> </ul>	<ul style="list-style-type: none"> <li>• Turn breaker(s) off and back on to see if unit comes on.</li> <li>• Check to make sure all the On/Off switches located on the front of the unit are turned on.</li> <li>• Make sure that none of the in line breakers on the front of the unit have been tripped. If so reset the breaker.</li> <li>• If the breaker and On/Off switches are both on and the unit is still not working call the Sertek service line for service.</li> </ul>

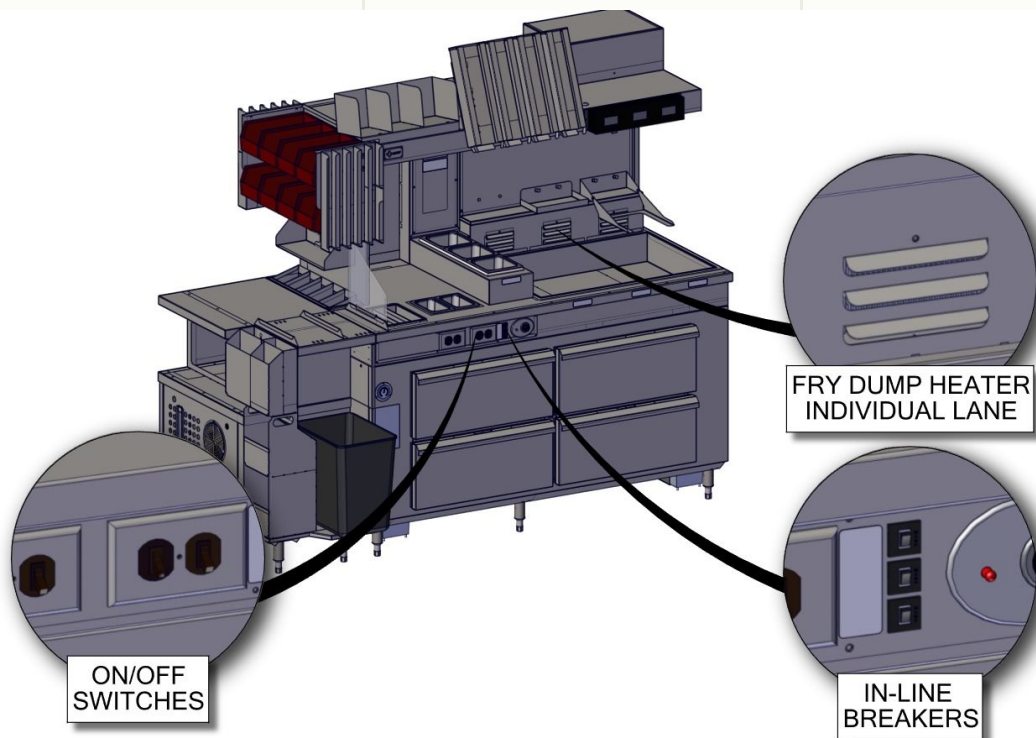

## TROUBLESHOOTING GUIDE (REFRIGERATION)

PROBLEM	POSSIBLE CAUSE	SOLUTION
CONDENSING UNIT IS NOT RUNNING	<ul style="list-style-type: none"> <li>• Breakers could be turned off</li> <li>• On/Off switch to condensing unit could be turned off</li> </ul>	<ul style="list-style-type: none"> <li>• Turn the breaker(s) off and back on to see if the unit comes back on.</li> <li>• Check to make sure the condensing unit's On/Off switch is turned on. To gain access to the switch remove the panel shown in the drawing below.</li> <li>• If the breaker and the power switch are both on and the unit is still not running call the Sertek service line.</li> </ul>

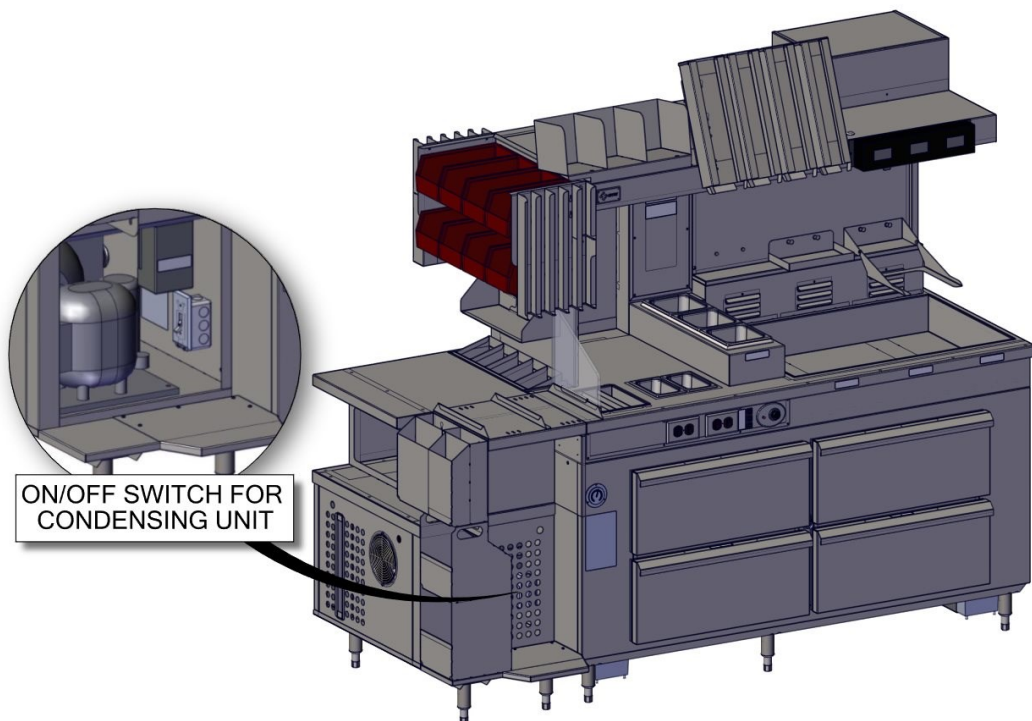

## TROUBLESHOOTING GUIDE (REFRIGERATION)

PROBLEM	POSSIBLE CAUSES	SOLUTION
<p>THE FANS ON THE INSIDE OF THE REFRIGERATION BOX ARE RUNNING BUT IT IS NOT KEEPING THE PRODUCT FROZEN OR THE TEMPERATURE IS TOO HIGH</p>	<ul style="list-style-type: none"> <li>• Air filter for the compressor condensing unit may be plugged up not allowing enough air to pass through condensing coil causing unit to overheat</li> <li>• Dual pressure control high side pressure switch may have tripped, causing the condensing unit to shut down</li> </ul>	<ul style="list-style-type: none"> <li>• Clean the air filter with a Wendy's approved cleaning agent.</li> <li>• Turn the power off and back on to the unit using the switch shown in the diagram on the previous page.</li> <li>• Looking on the back side of the condensing unit, you will see a 3"x6" gray or white plastic box with 2 clear windows on it, on the right window there is a push button. Push this button in and listen for the click. When the button clicks you have reset the control. Replace all the covers for the unit and switch the power back on. If the unit still does not run call the Sertek line for service.</li> </ul>

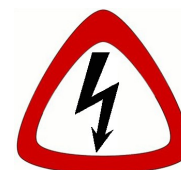
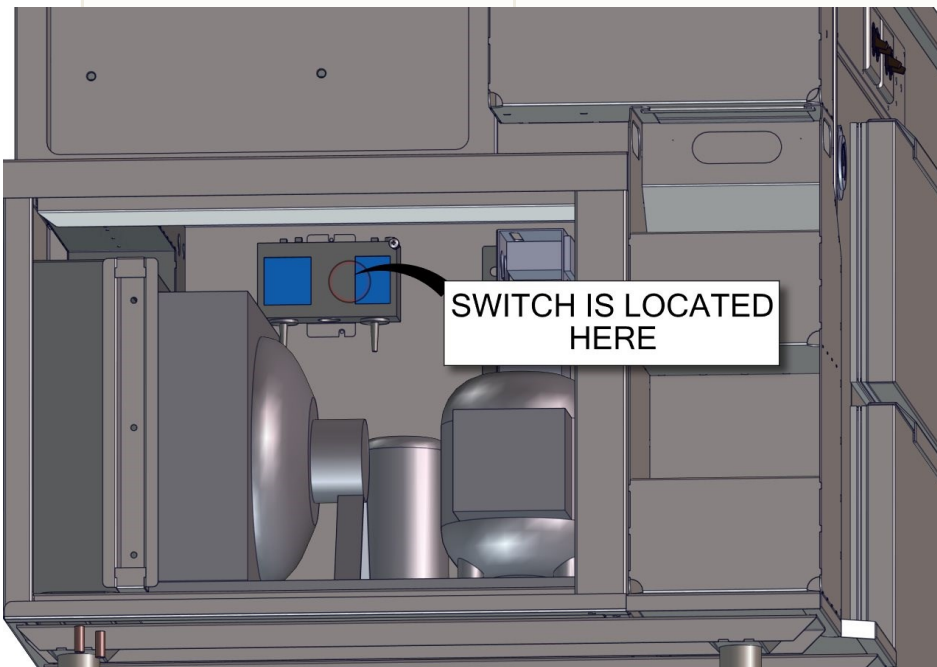

## ACCESS GUIDE FOR SERVICE TECHNICIANS

### Accessing the condensing cabinet

There are several points of access in the condensing cabinet. The first two points of access are the removable panels on the side and front of the cabinet.

**CAUTION: DISCONNECT POWER FROM THE UNIT BEFORE REMOVING SHELF.**

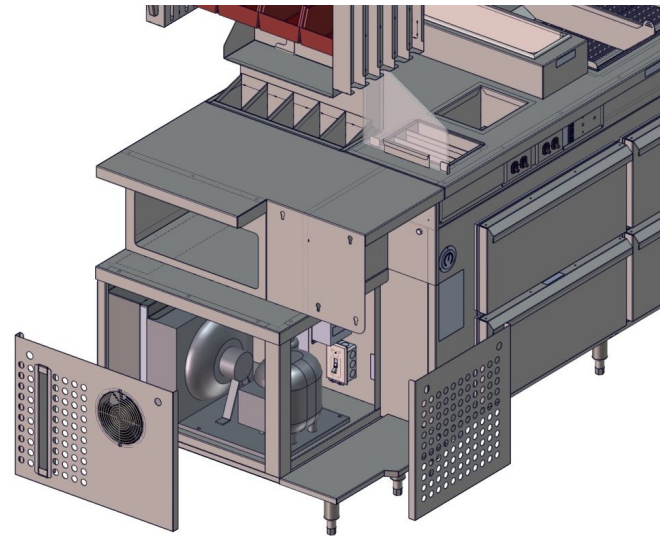

Removable Panels

The prep shelf is also removable. There are eight 7/16" hex head bolts fastening the shelf to the Fry Dump as well as two 7/16" cap nuts on the condensing cabinet frame. Remove all eight bolts and the lift up on the shelf to disconnect it from the Fry Dump.

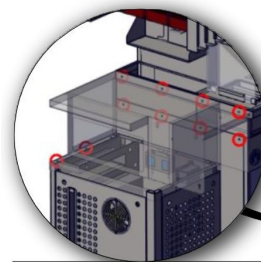

Eight 7/16" Hex Bolts  
Two 7/16" Cap Nuts

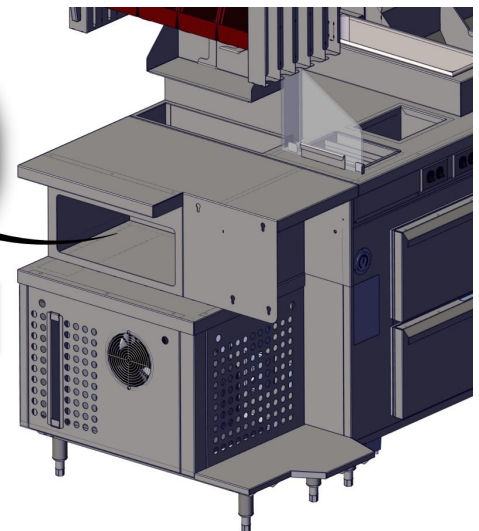

Lift off to remove

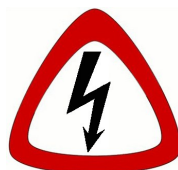
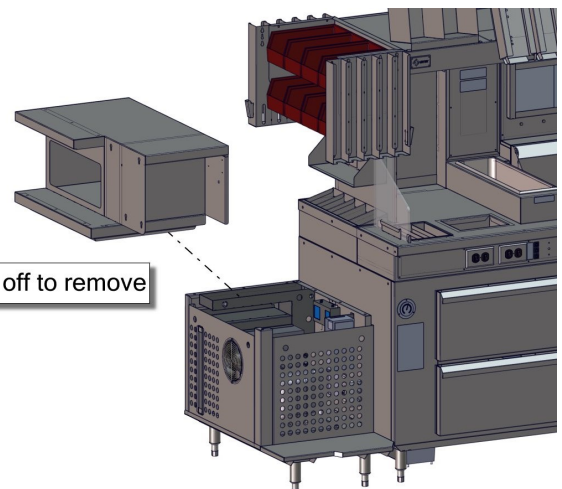

# ACCESS GUIDE FOR SERVICE TECHNICIANS

## ACCESSING THE L.E.D LIGHT PANEL AND TRANSFORMER

The L.E.D lights and Henny Penny Timer receive power from a transformer located in the top back section of the fry dump. To access this transformer you will need to remove an access panel on the top of the unit.

**CAUTION SHOCK HAZARD: BEFORE REMOVING THIS PANEL ENSURE THE UNIT IS OFF AND ALL PROPER LOCK-OUT TAG-OUT PROCEDURES HAVE BEEN PERFORMED**

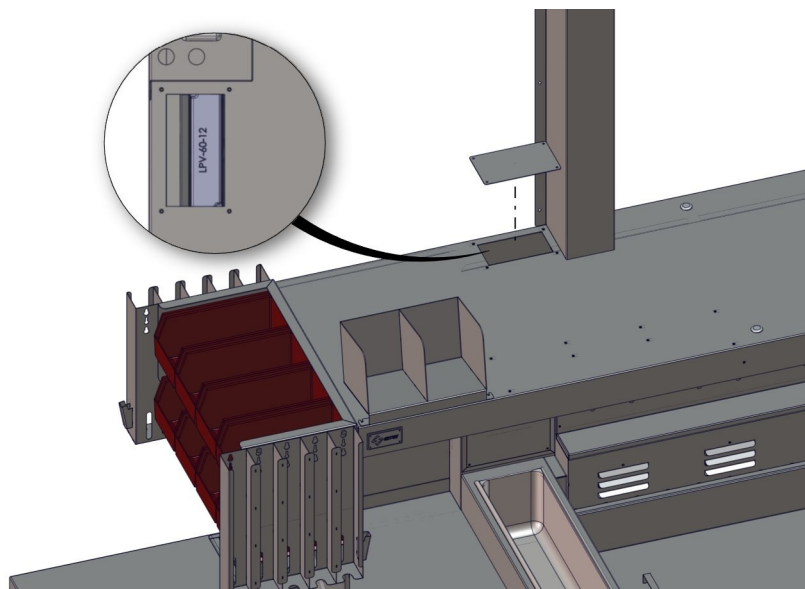

There are two phillips-head screws holding the L.E.D light strip panel in place. Remove these screws and the panel can be pulled down for servicing.

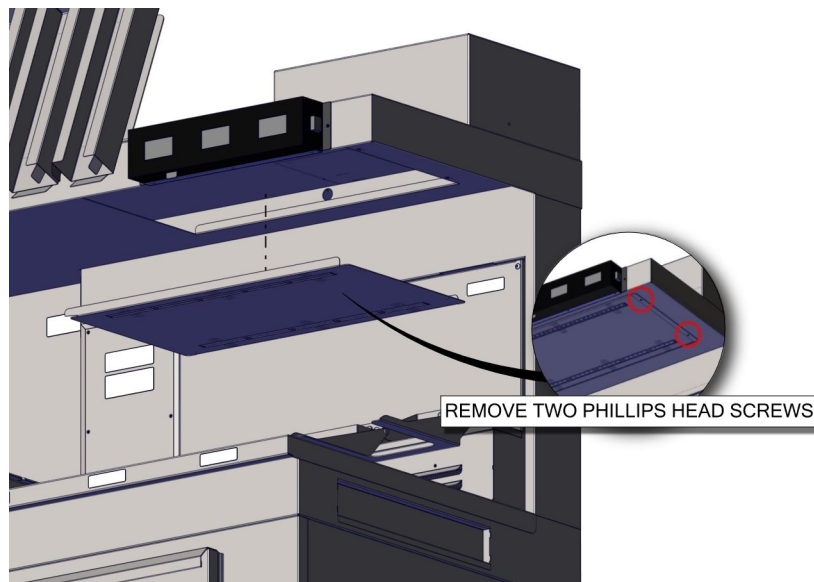

# ACCESS GUIDE FOR SERVICE TECHNICIANS

## ACCESSING THE FRY LANE HEATER INSERTS

There are three fry lane heater inserts in the Hot and Crisp fry dump. Each insert plugs into its own outlet and they can be turned off using the left most three brown switches in the front of the unit. To gain access to the heater inserts remove the fry lane pans, salt shelf, and nugget holding bracket. Next remove the four phillips-head screws holding the cover panel in place and the three screws holding the individual heater assemblies in place. With the screws removed the panel can now be lifted off and set aside.

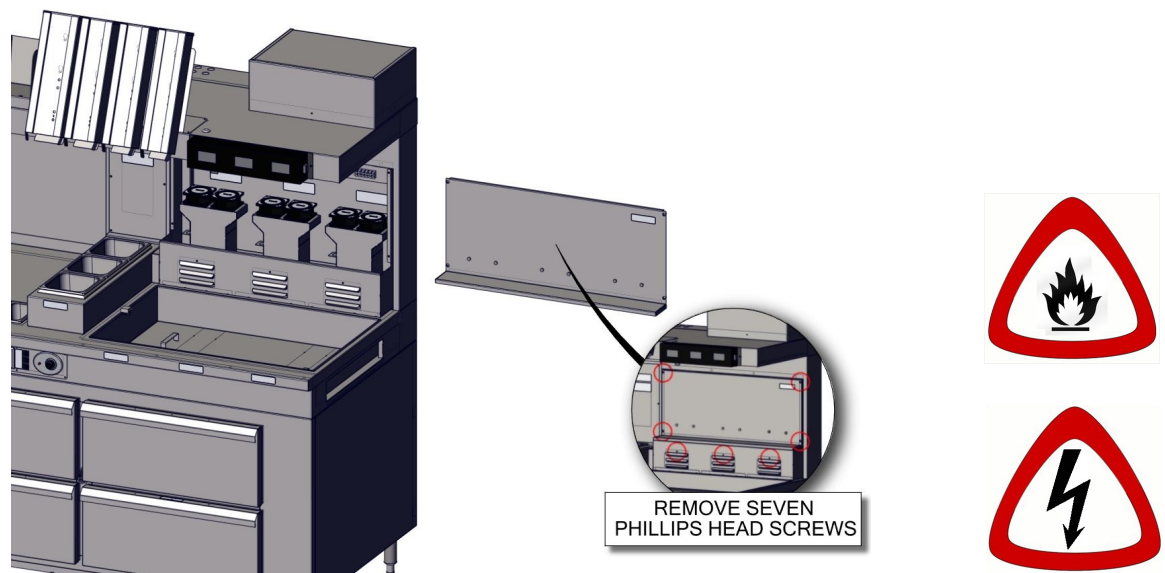

With all the screws removed and the front panel taken off you now have clear access to the heater assemblies. Disconnect the heater insert's wiring from the terminal block then lift the heater up and out for servicing.

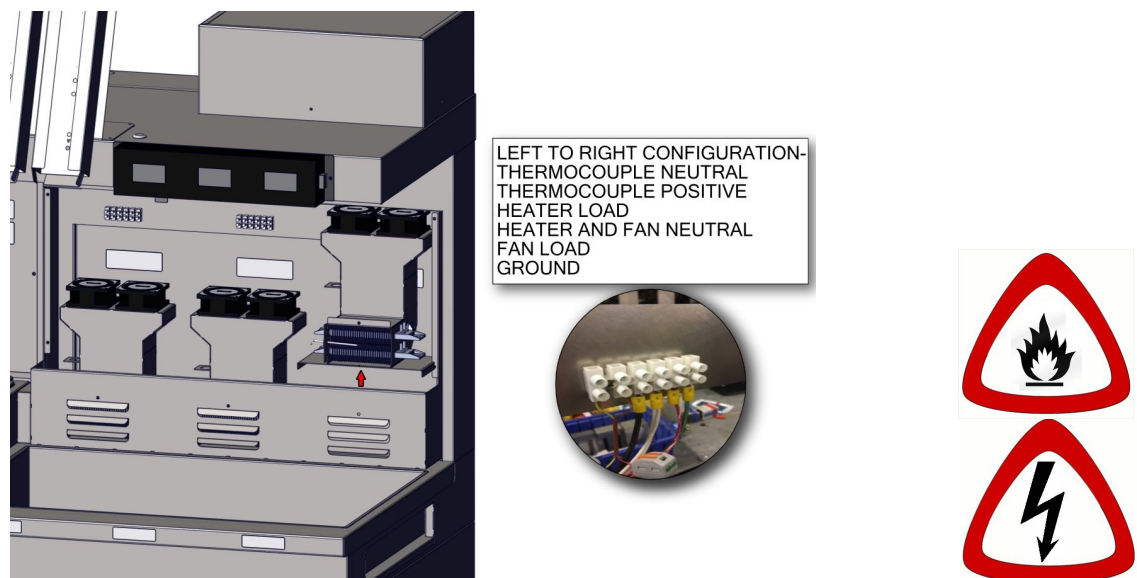

## ACCESS GUIDE FOR SERVICE TECHNICIANS

### ACCESSING THE EVAPORATORS AND EXPANSION VALVE.

In order to reach the evaporators and expansion valve you will need complete access to the freezer bay. To accomplish this you will need to remove the drawer assembly inserts. First remove all the pans from the drawer slides. Next remove the four 7/16" bolts securing the inserts to the freezer bay.

The top two bolts are located on the sides of the chassis as shown below.

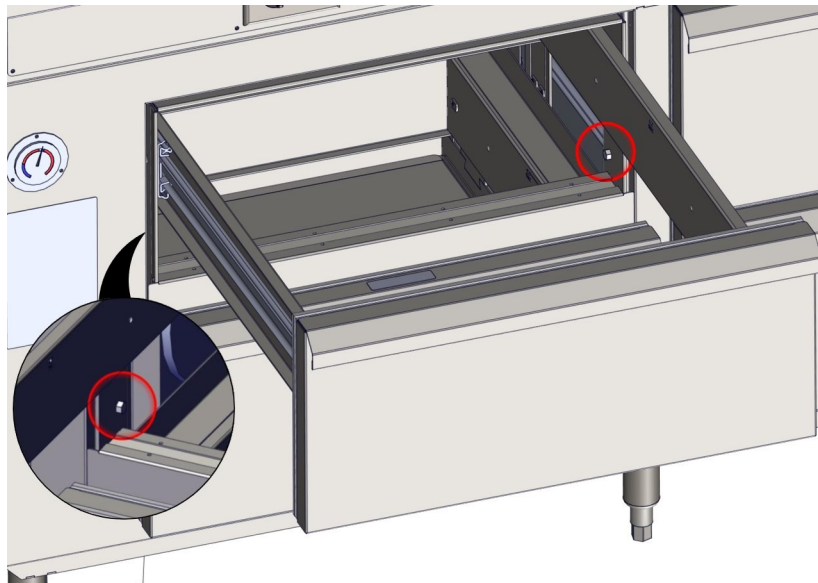

Remove the two bolts from the bottom and the drawer assembly insert can be pulled out of the freezer bay.

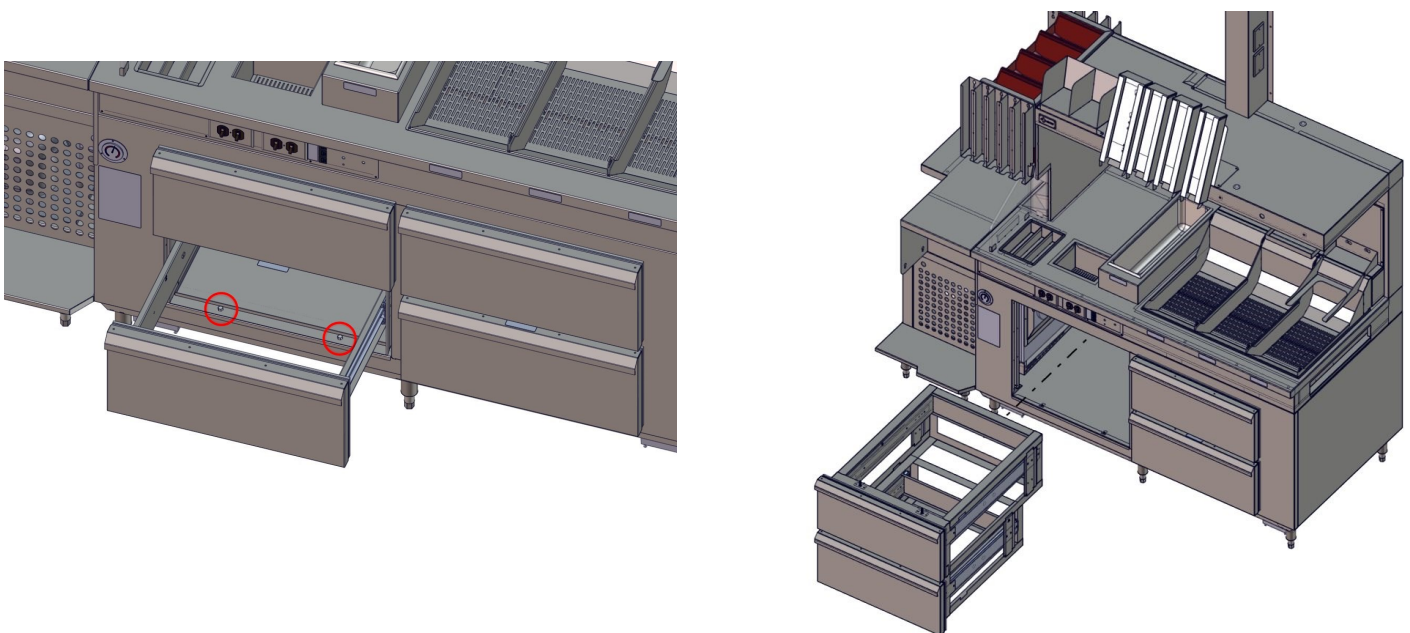

## ACCESS GUIDE FOR SERVICE TECHNICIANS

### ACCESSING THE EVAPORATORS AND EXPANSION VALVE.

With the drawer assemblies removed from the unit you now have complete access to both the evaporators.

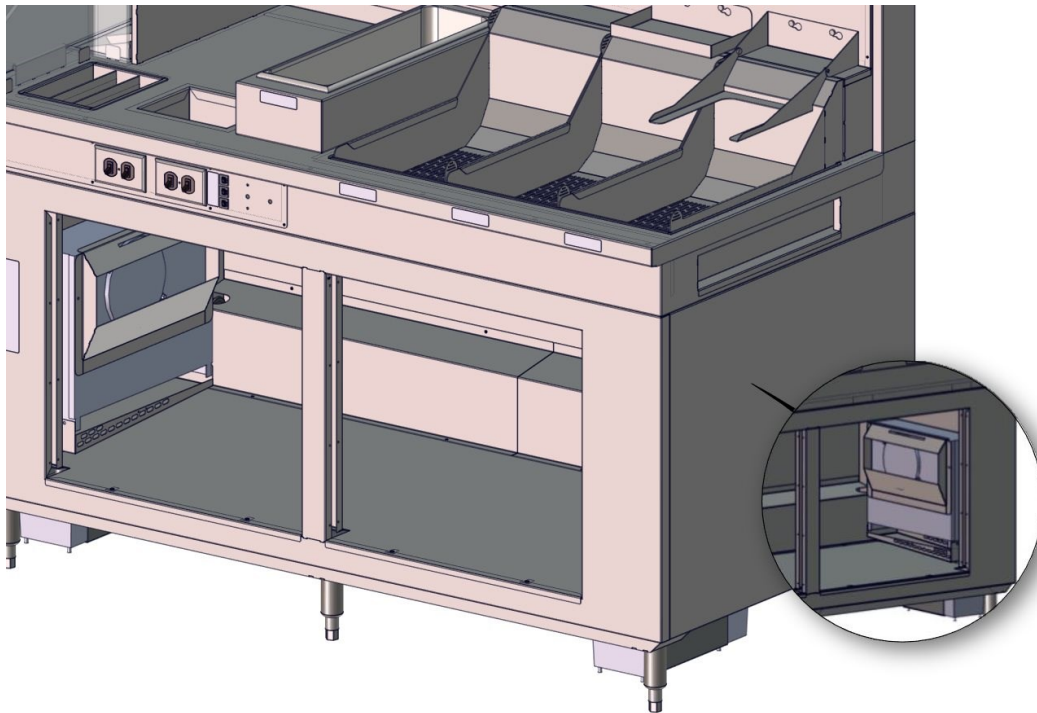

To access the expansion valve, remove the housing in the back of the freezer bay by taking out the eight phillips-head screws holding the two panels in place.

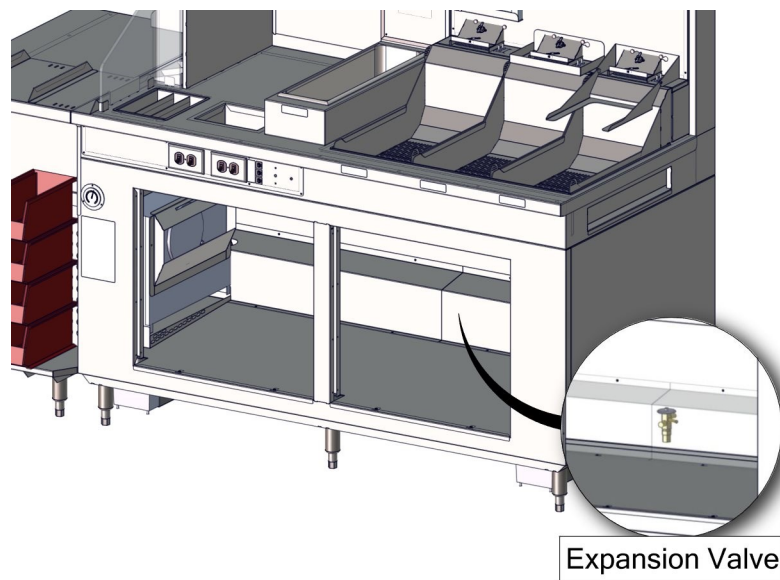

# ACCESS GUIDE FOR SERVICE TECHNICIANS

## ACCESSING THE HPM6 WARMER HEATING ELEMENT

To access the Wells HPM6 food warmer's heating element you will first need to remove the panel on the front of the Fry Dump. This panel is held in place with eight phillips-head screws. **CAUTION SHOCK HAZARD: BEFORE REMOVING THIS PANEL ENSURE THE UNIT IS OFF AND ALL PROPER LOCK-OUT TAG-OUT PROCEDURES HAVE BEEN PERFORMED**

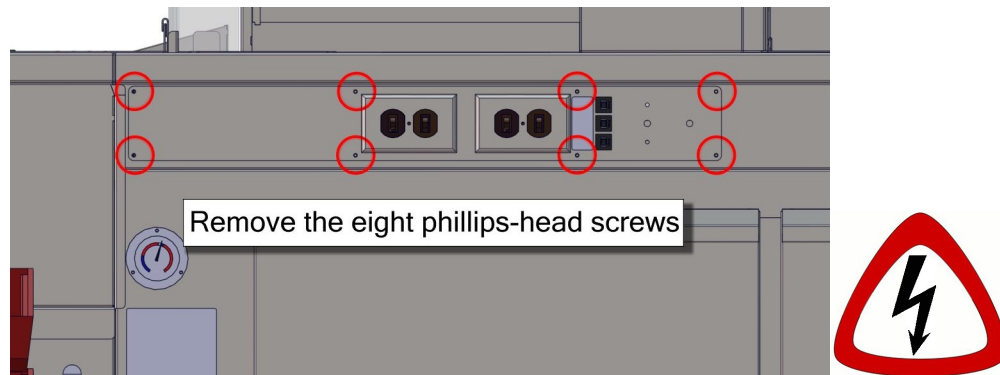

With the front panel removed you now have access to the bottom of the HPM6 warmer. There are two phillips-head screws holding the warmer in place, remove these two screws. Next cut the silicon that is sealing the base of the warmer to the shelf of the Fry Dump, keep in mind that this silicon will need to be replaced so it is a good idea to remove all the silicon debris at this time. With the two screws and bead of silicon removed the heater can now be pulled out of the unit and serviced.

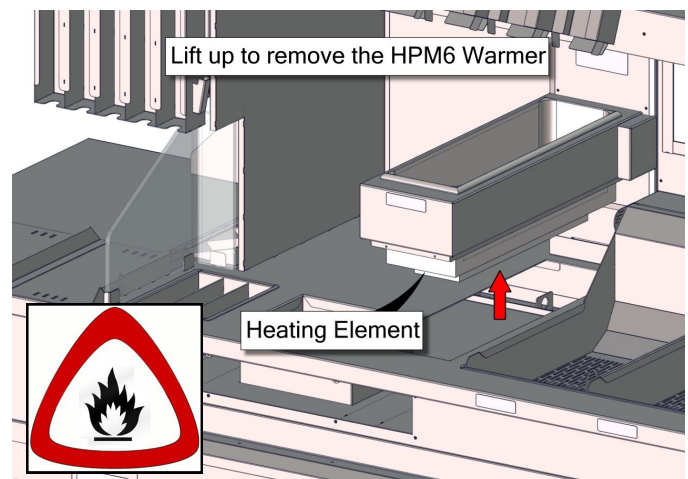
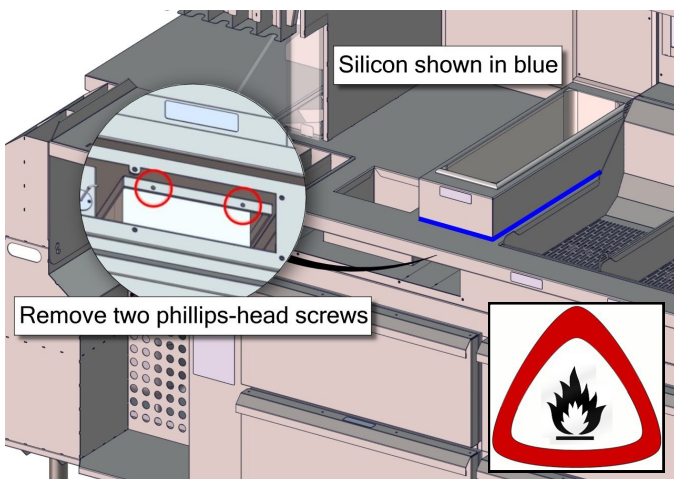

# ELECTRICAL REQUIREMENTS/ ELECTRICAL WIRING SCHEMATICS

120 Volt 20 Amp Service with a 20 Amp breaker

## CIRCUIT 1

- Marshall Air Unit
- Three Row Fry Staging Ribbon
- LED Lights
- Henny Penny Timer

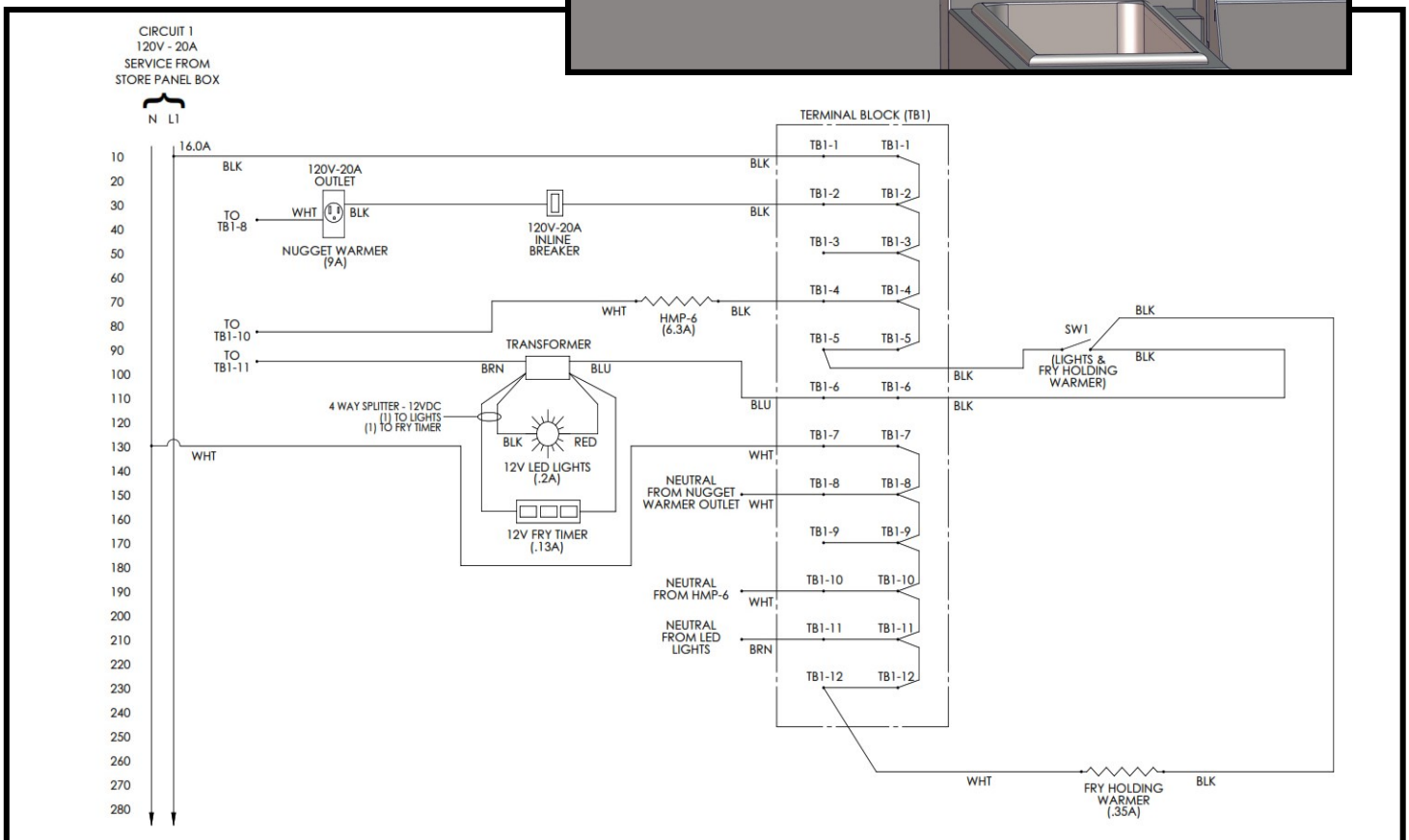
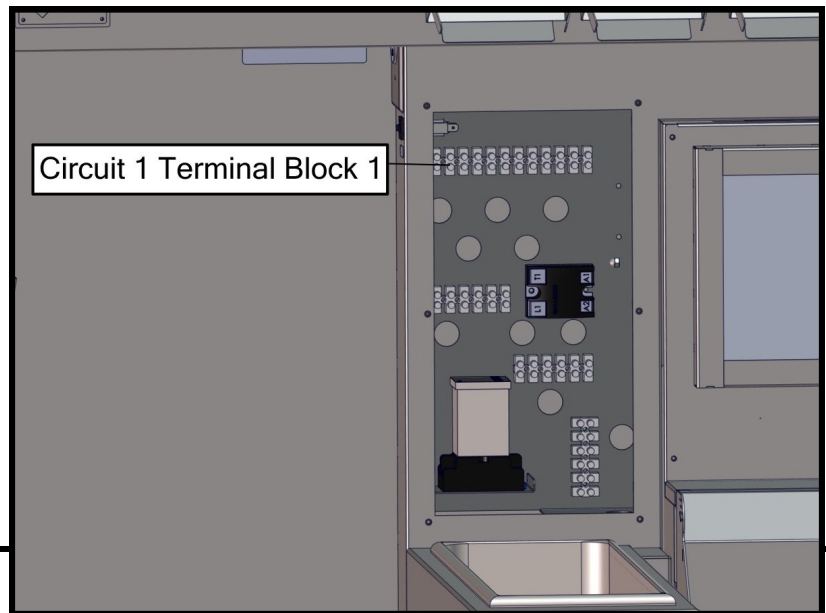

# ELECTRICAL REQUIREMENTS/ ELECTRICAL WIRING SCHEMATICS

120 Volt 30 Amp Service with a 30 Amp breaker

## CIRCUIT 2

- Fry Lanes 2 and 3

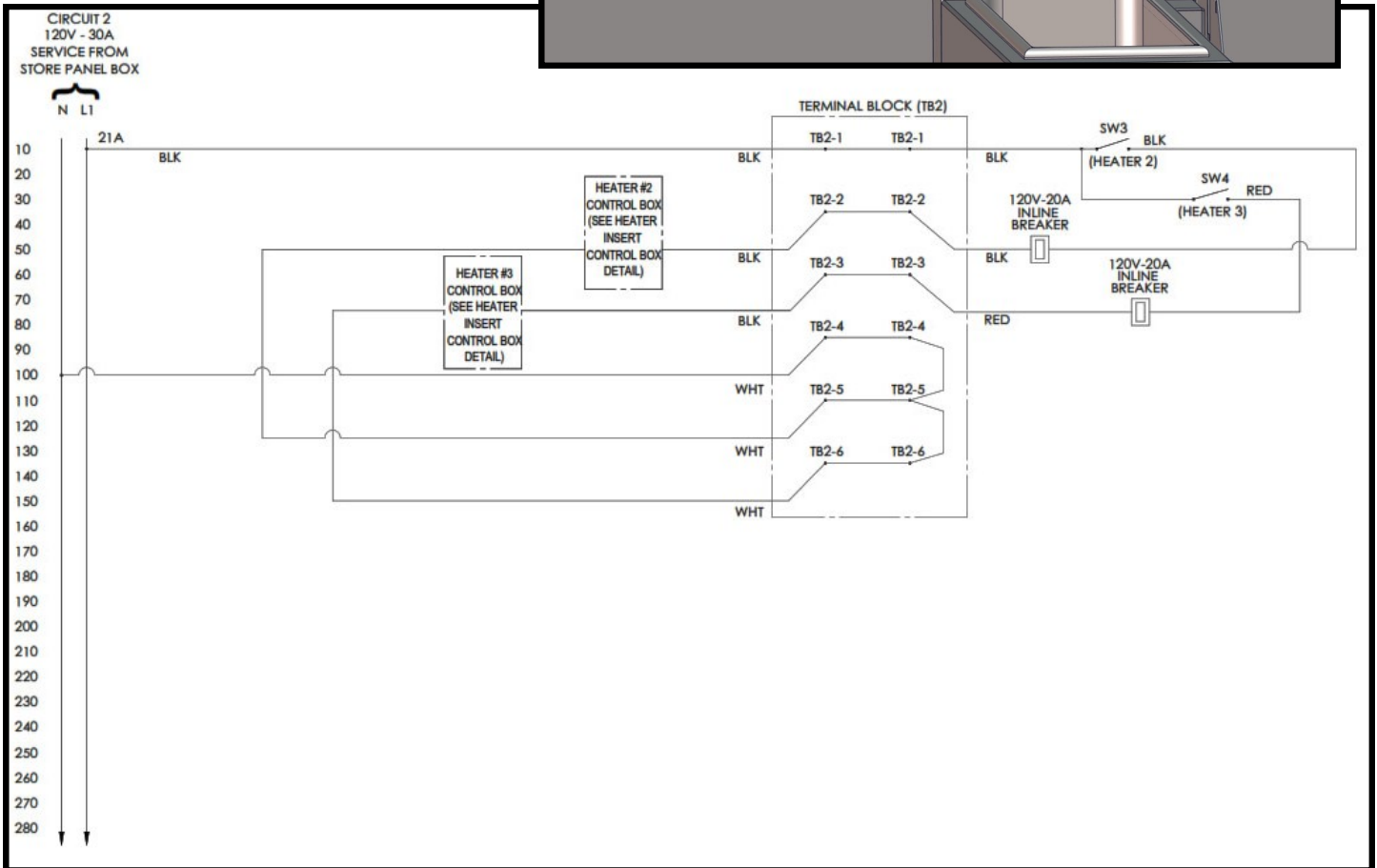
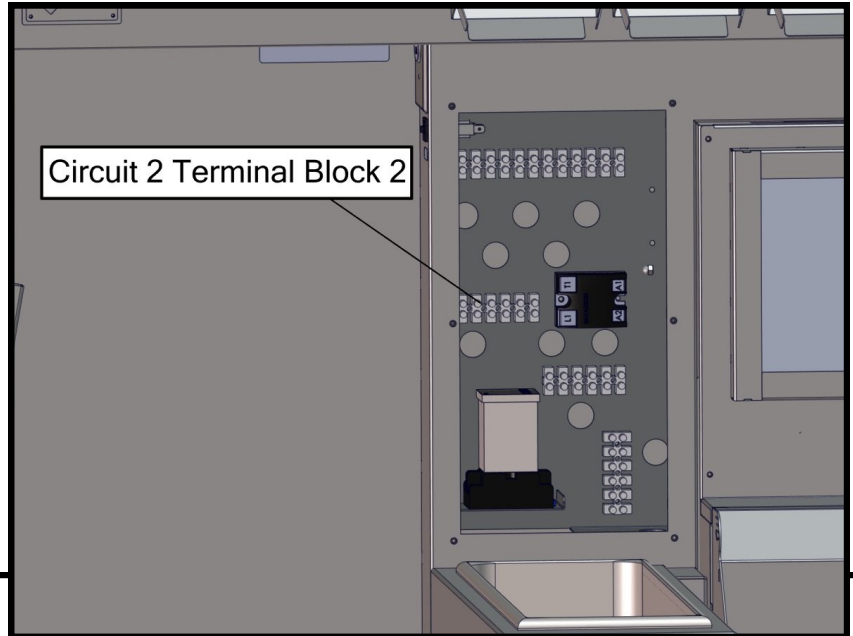

# ELECTRICAL REQUIREMENTS/ ELECTRICAL WIRING SCHEMATICS

120 Volt 20 Amp Service with a 20 Amp breaker

## CIRCUIT 3

- Fry lane 1

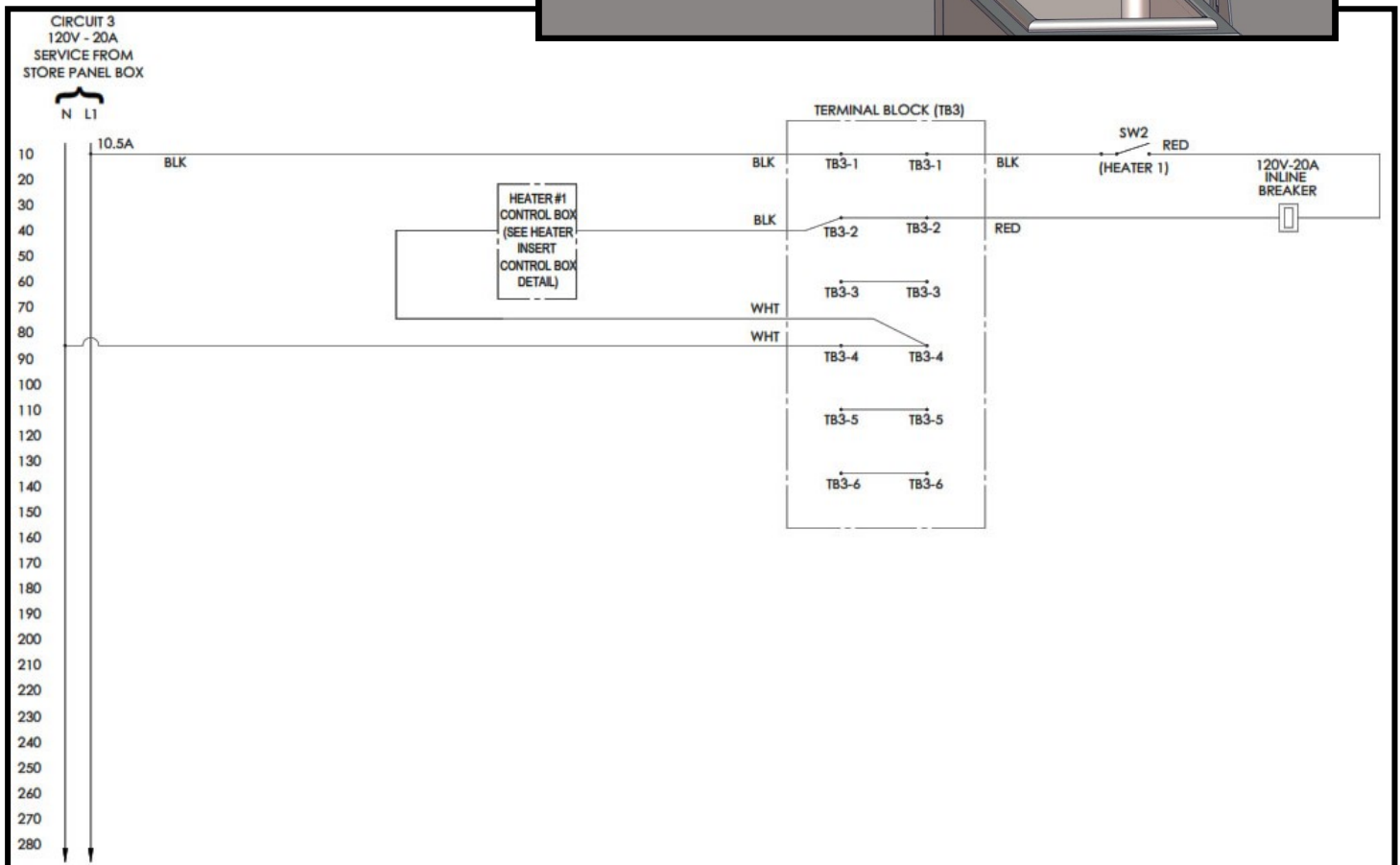
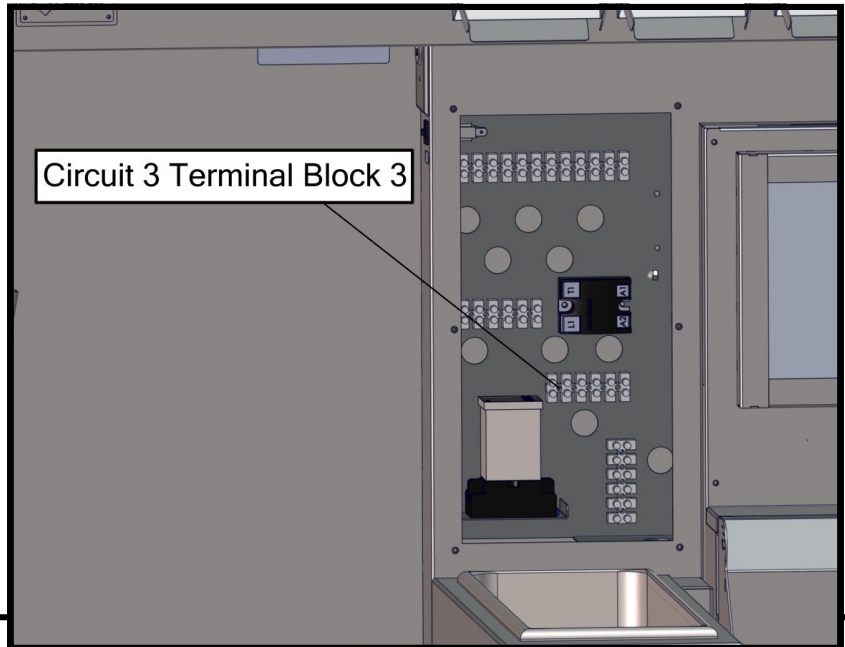



# RU0051 TEMPERATURE CONTROL



- Temperature Controller
- Contactor

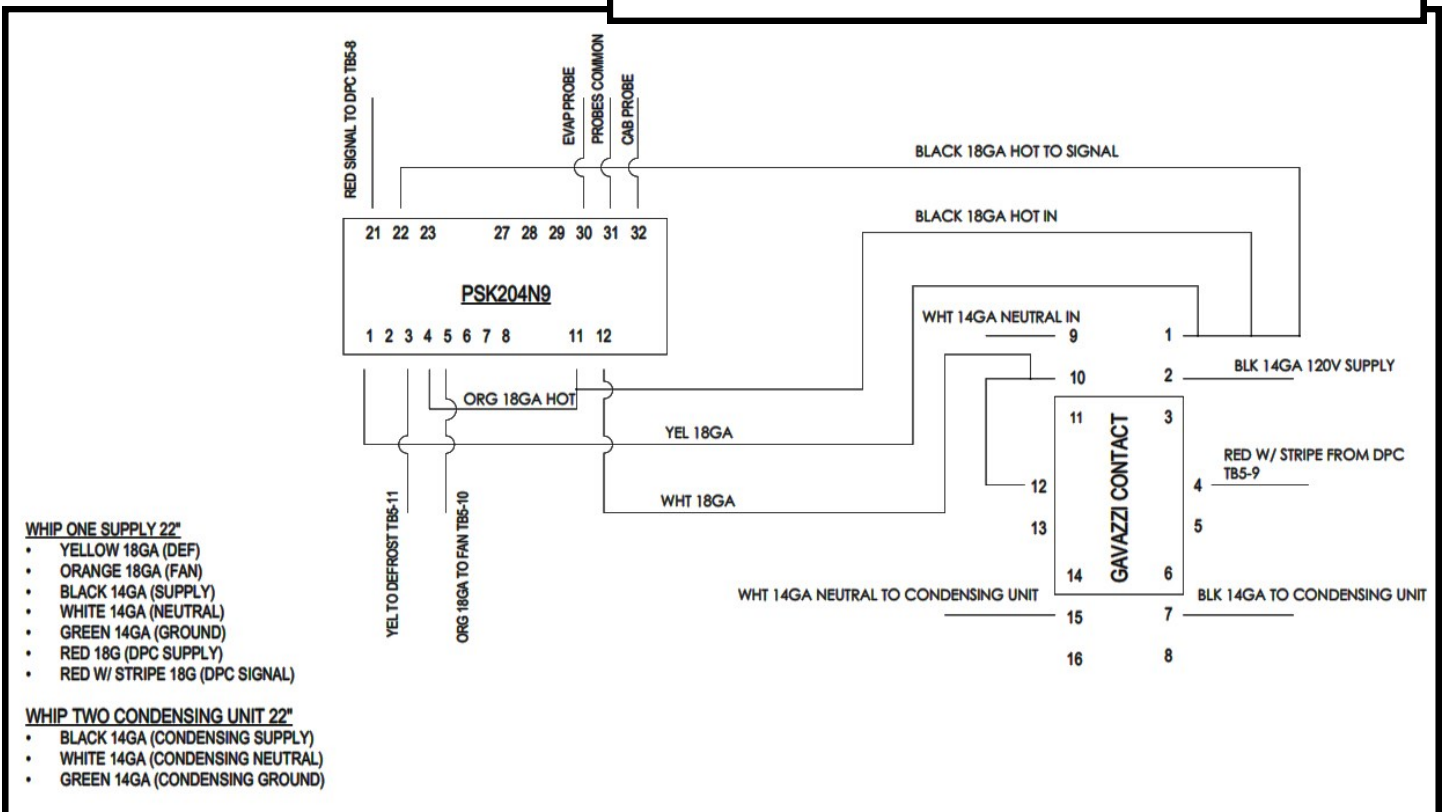
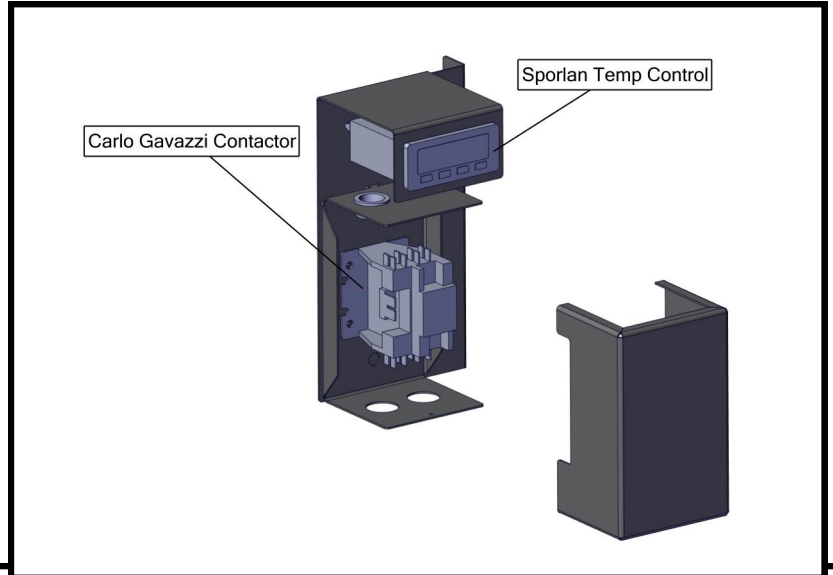



# FD018108-119 FRY LANE HEATER CONTROL BOX ELECTRICAL WIRING SCHEMATICS



- Terminal Block 6
- (3) Temperature Controllers
- (3) Solid State Relays
- (3) Time Delay Relays
- Pulls between 9.4-10.5 amps (each lane)

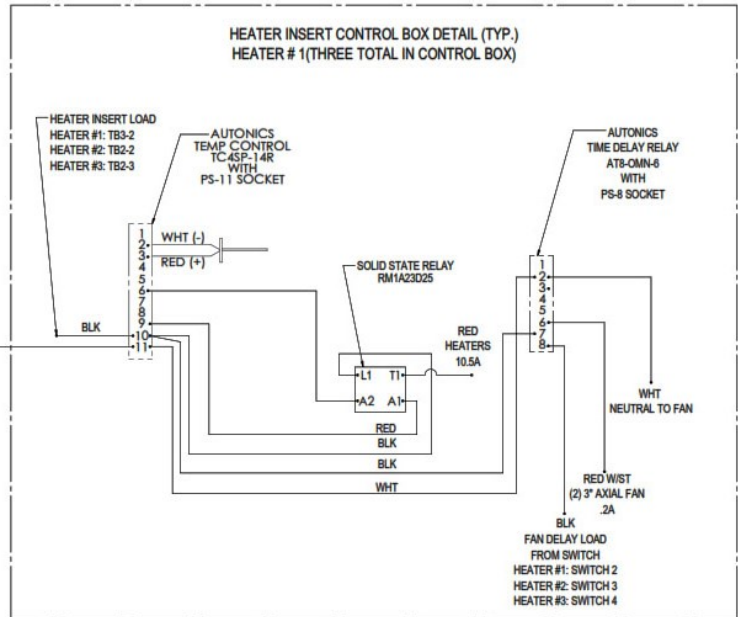
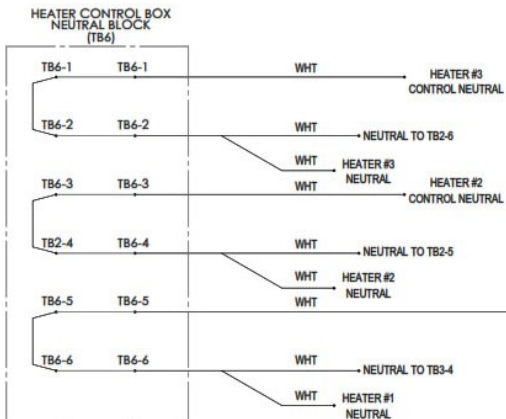
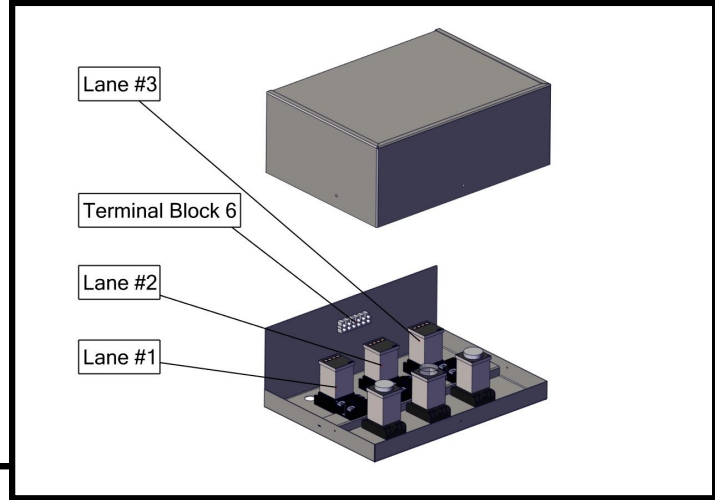

# TECHNICAL ILLUSTRATIONS

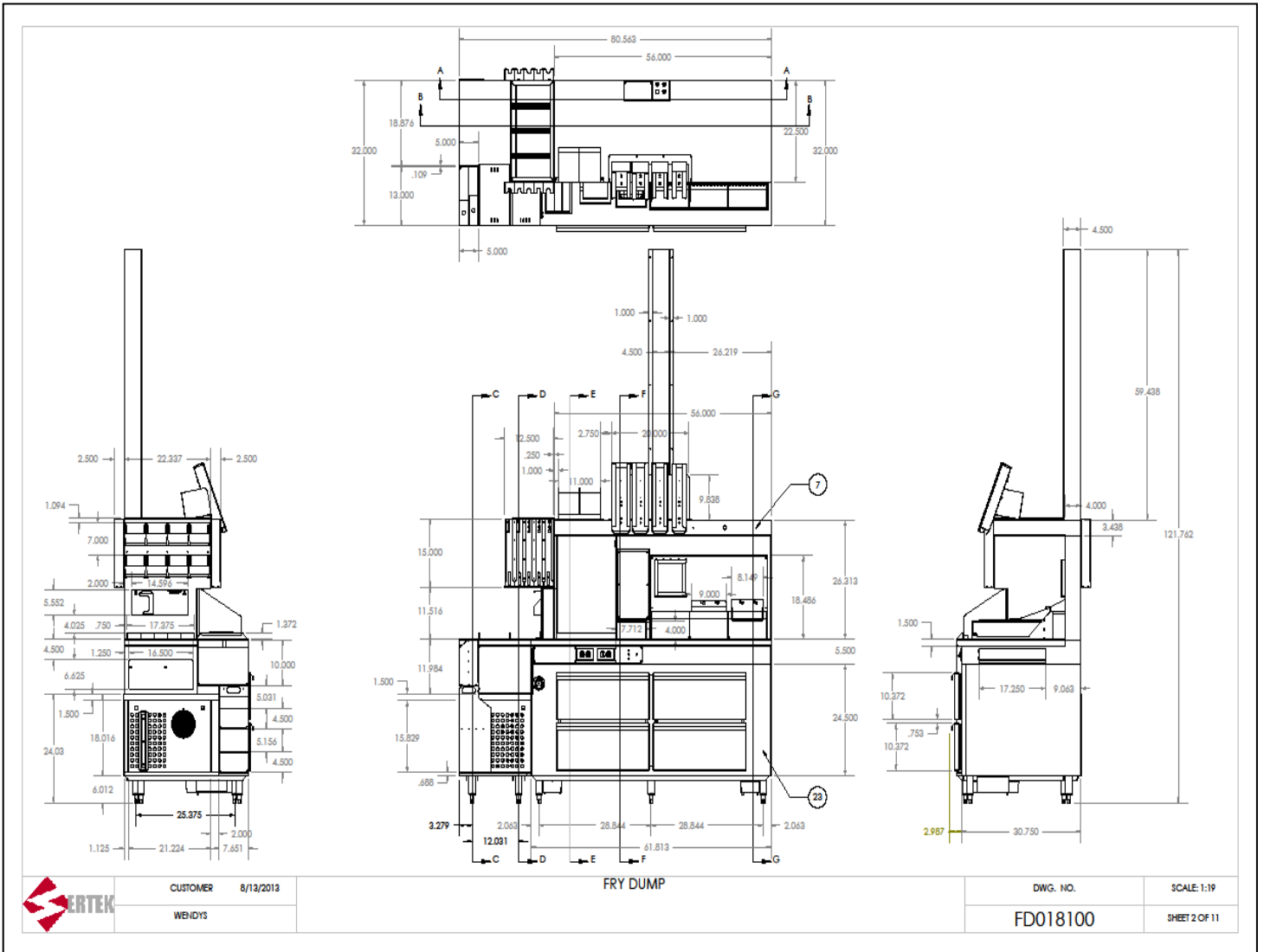











The latest in technology, the very best in service

SERTEK

HOT & CRISP FRY STATION

MODEL FD018108

OWNER'S MANUAL

7FD018108-MNL1.112217

R.S 11/22/17 V1