

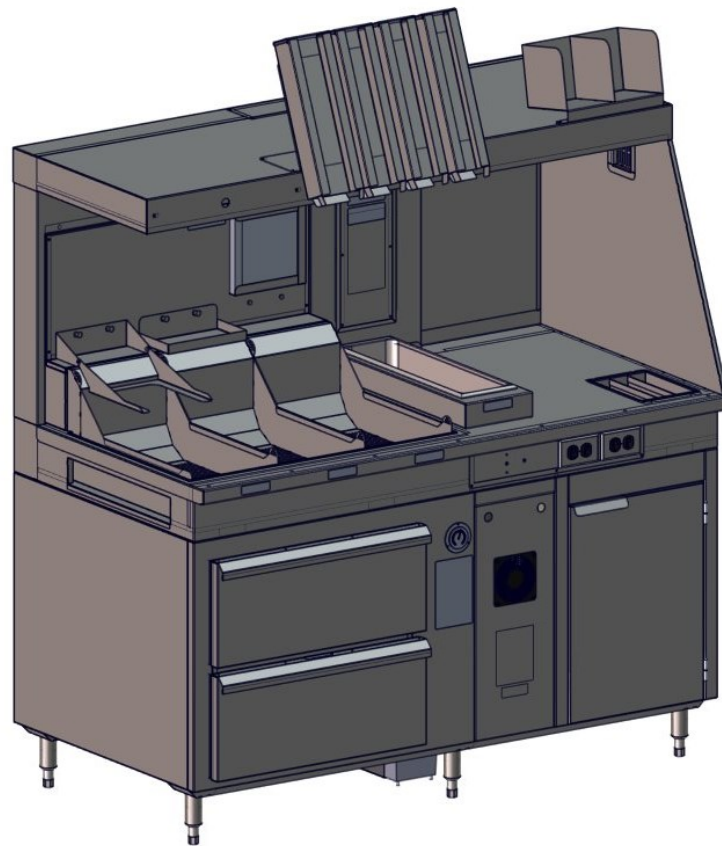

Hot & Crisp Fry Station

MG3 Model FD016000



Replacement Parts Catalog



PRODUCT DETAILS

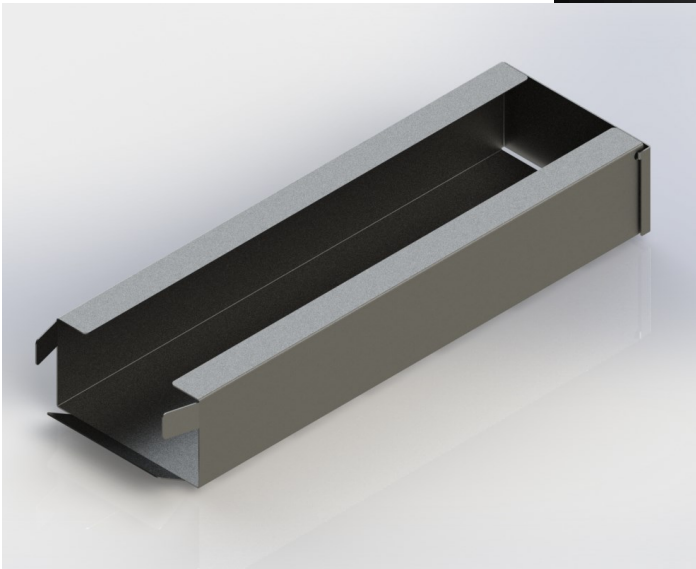

Function

- **Holds Large Size Fry Cartons**

Features

- **Easy to use keyhole style mounting system**
- **Easy load swing open top**

FD018126-L

Dimensions: 16" H x 4.93" W x 2.5" D

Weight: 1.7lbs

FD018126-L Fry Carton Dispenser



PRODUCT DETAILS

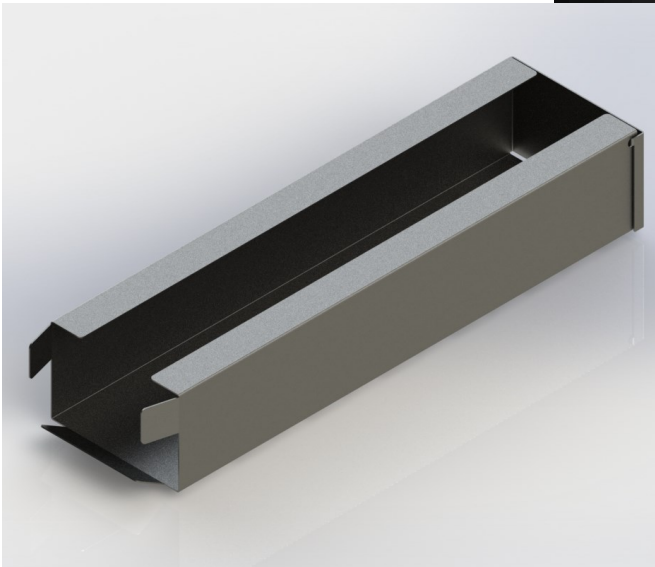

Function

- Holds Medium Size Fry Cartons

Features

- Easy to use keyhole style mounting system
- Easy load swing open top

FD018126-M

Dimensions: 16" H x 4.18" W x 2.75" D

Weight: 1.7lbs

FD018126-M Fry Carton Dispenser



PRODUCT DETAILS

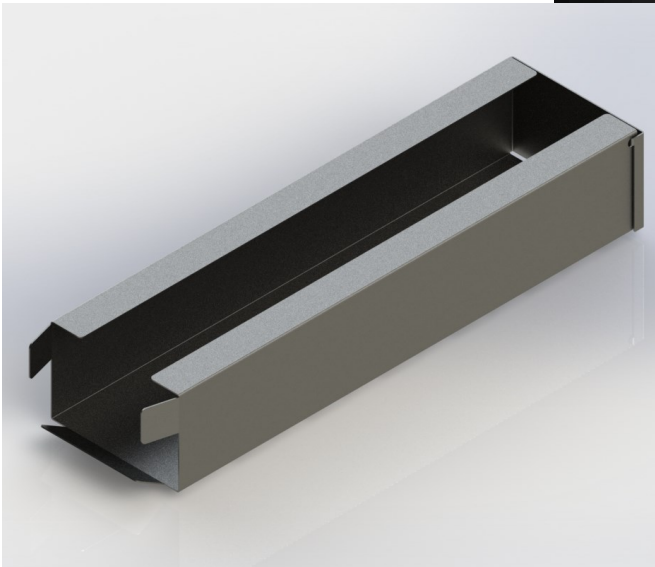

Function

- Holds Small Size Fry Cartons

Features

- Easy to use keyhole style mounting system
- Easy load swing open top

FD018126-S

Dimensions: 16" H x 4.18" W x 2.75" D

Weight: 1.7lbs

FD018126-S Fry Carton Dispenser

FD018126-V



PRODUCT DETAILS

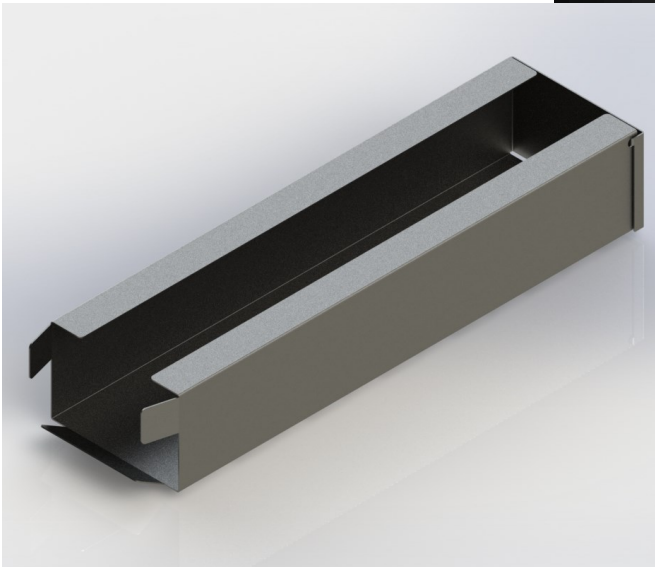

Function

- Holds Value Size Fry Cartons

Features

- Easy to use keyhole style mounting system
- Easy load swing open top

FD018126-V

Dimensions: 16" H x 4.18" W x 2.75" D

Weight: 1.7lbs

FD018126-V Fry Carton Dispenser



PRODUCT DETAILS

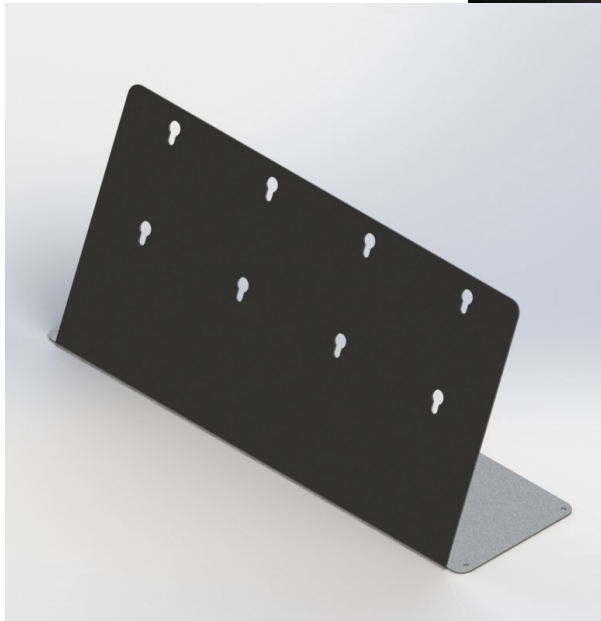

Function

- **Mounting Bracket For Fry Carton Dispensers**

Features

- **Easy to use keyhole style mounting system**
- **Fits large, medium, small, and value dispensers**

FD018125

Dimensions: 9.62" H x 21.5" W x 6.12" D

Weight: 7lbs

FD018125 Fry Carton Bracket

7000732-8



PRODUCT DETAILS

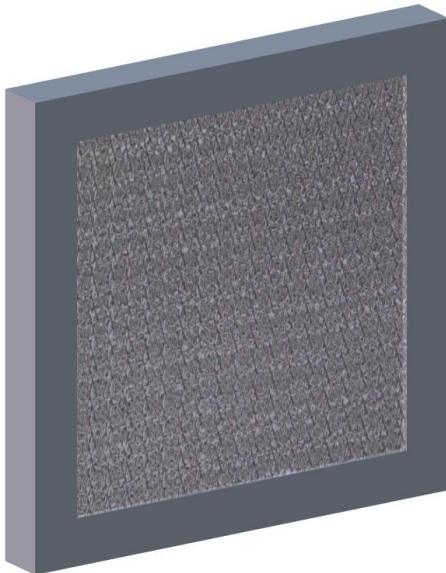

Function

- **8"x8" Air Filter**

Features

- **Wire mesh design for easy cleaning**

7000732-8

Dimensions: 8" H x 8" W x .5" D

Weight: .546lbs

7000732-8 8x8 Air Filter

FD018131



PRODUCT DETAILS



Function

- Fry Station Double Salt Shelf

Features

- Holds two salt shakers
- Easy to use keyhole mounting style

FD018131

Dimensions: 2.5" H x 9" W x 5" D

Weight: 1.4lbs

FD018131 Double Salt Shelf

FD018132



PRODUCT DETAILS

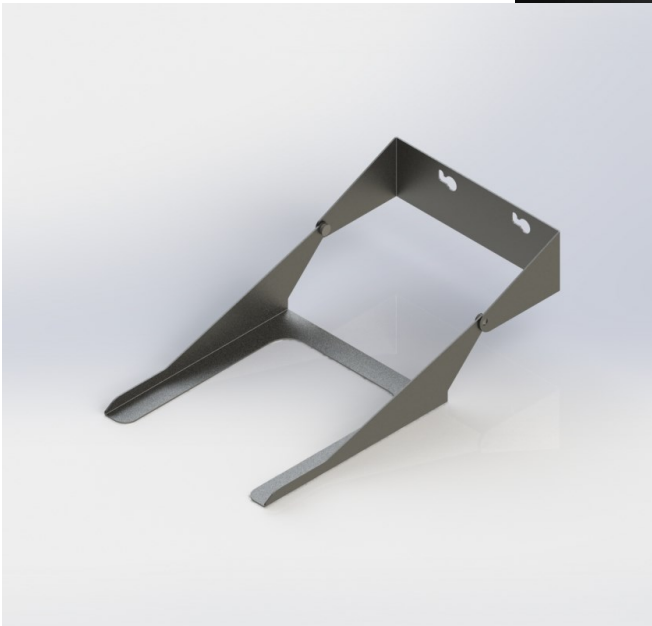

Function

- Holds Ready Chicken Nuggets

Features

- Easy to use keyhole style mounting system

FD018132

Dimensions: 3" H x 8" W x 15.12" D

Weight: 1.3lbs

***FD018132 Nugget Holding Pan
Bracket***



PRODUCT DETAILS

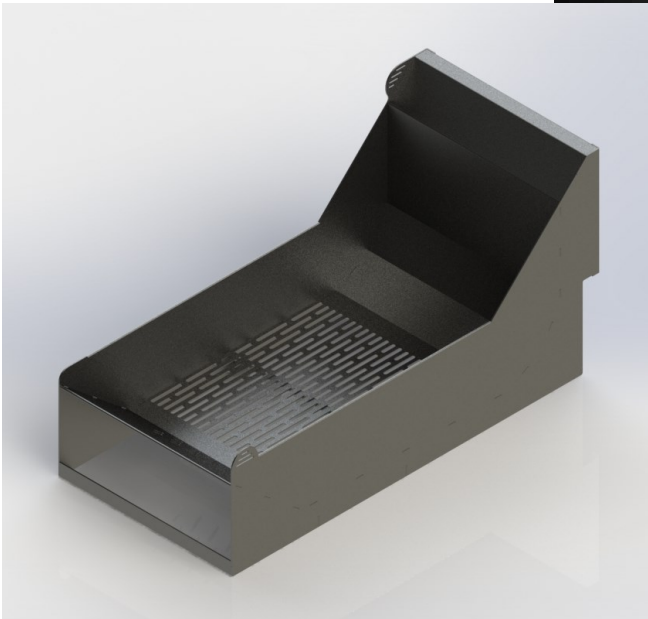

Function

- Holds Cooked Fries

Features

- Separates fries for consistency
- Holds one basket of fries

FD018122

Dimensions: 10.62" H x 10" W x 21.06" D

Weight: 9lbs

FD018122 Fry Dump Pan

FD014123



PRODUCT DETAILS

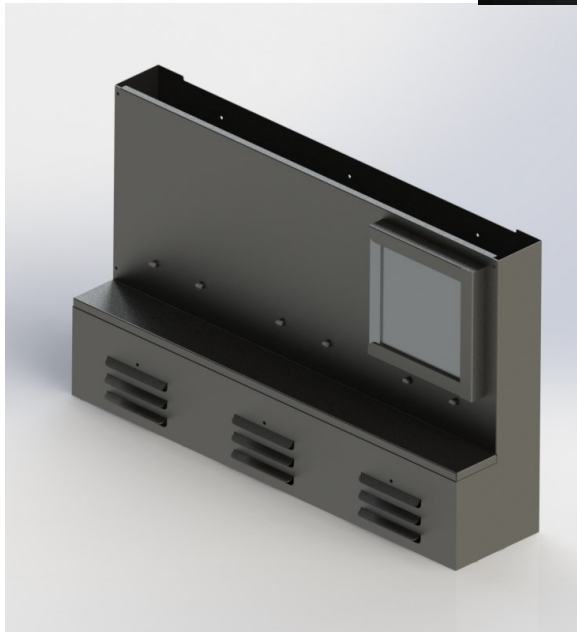

Function

- **Holding Box For Fry Lane Heater Inserts**

Features

- **Easy to remove filter**
- **Heats all three fry lanes**

FD014123

Dimensions: 18.31" H x 30.06" W x 6.81" D

Weight: 22lbs

FD014123 Fry Lane Heater Box



PRODUCT DETAILS

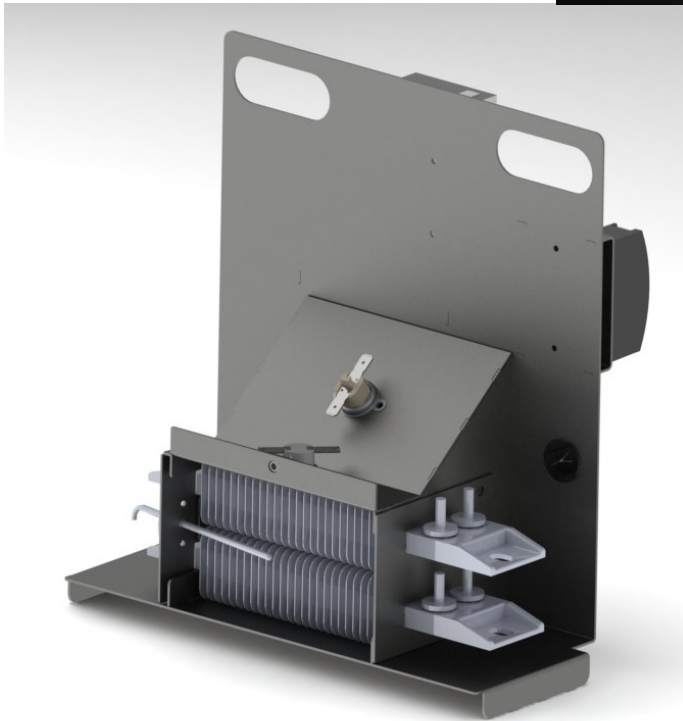

FD018124

Dimensions: 10.06" H x 9.7" W x 5.95" D

Weight: 6lbs

Operating Voltage

- **120 Volts, 10.5 Amp, 1250 Watt operation**

Function

- **Single lane forced air fry heating system**

Features

- **1250 watts of heating power**
- **Dual safety limits**
- **Programmable thermostat**

FD018121



PRODUCT DETAILS

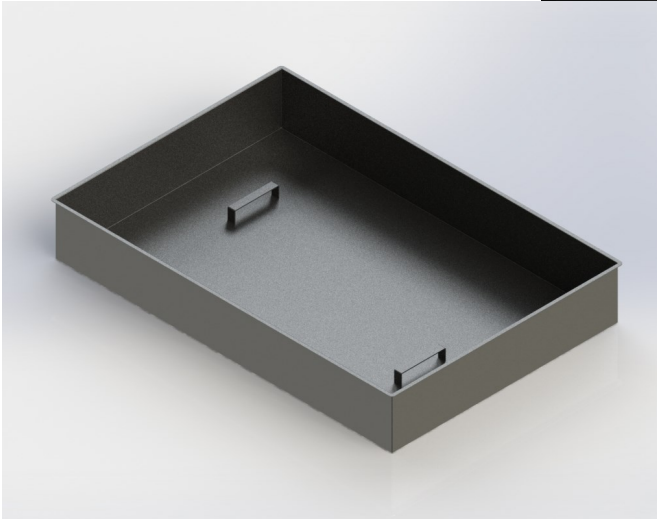

Function

- Holds (3) Fry Dump Pans

Features

- Easy lift handles for cleaning

FD018121

Dimensions: 4.62" H x 20.75" W x 30.62" D

Weight: 15lbs

FD018121 Fry Lane Holding Pan

FD018127



PRODUCT DETAILS

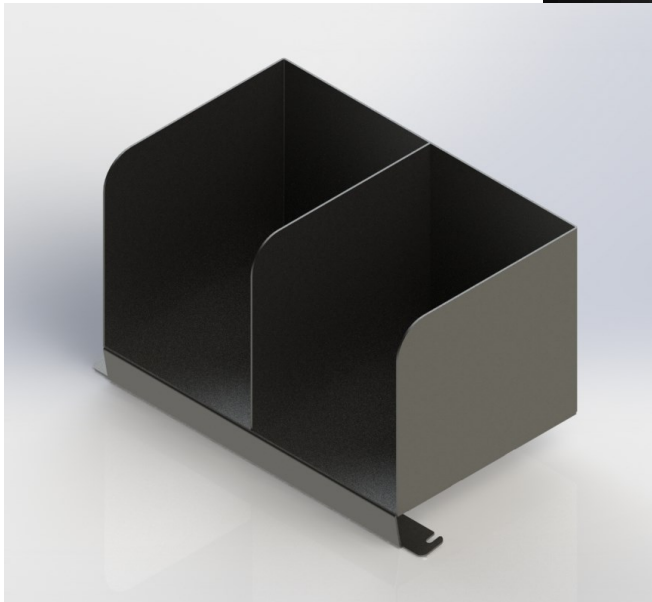

Function

- **Chili Cheese Fry Tray And Lid Holder**

Features

- **Holds both trays and lids for chili cheese fries**

FD018127

Dimensions: 7.18" H x 12.37" W x 6.75" D

Weight: 5lbs

***FD018127 Chili Cheese Fry
Tray & Lid Holder***

FD018128



PRODUCT DETAILS



Function

- Heated Fry Staging Ribbon

Features

- Heated fry holding
- 3 rows hold several ready orders of any size

FD018128

Dimensions: 2.31" H x 6.93" W x 9.18" D

Weight: 2.3lbs

FD018128 3 Row Fry Staging Ribbon

FD018142



PRODUCT DETAILS

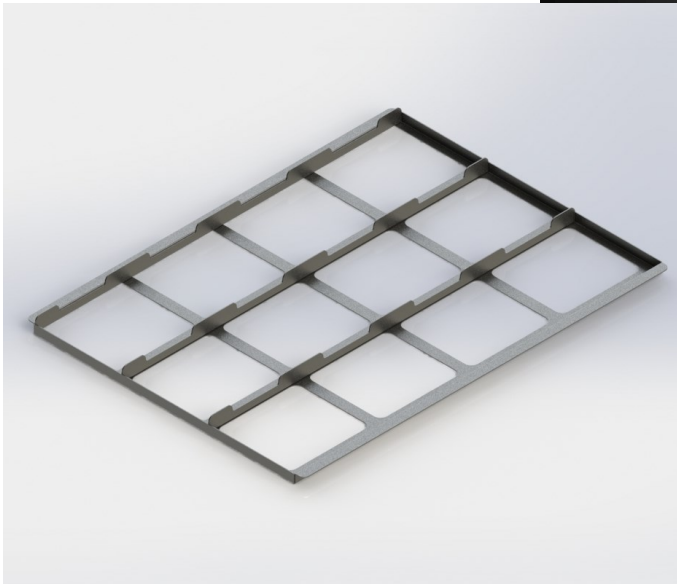

Function

- **Insert For Fry Station Portioning Pan**

Features

- **Holds (12) 1/6th size pans for fry portioning**
- **Easy removal for cleaning**

FD018142

Dimensions: 1.25" H x 21.25" W x 28" D

Weight: 6lbs

FD018142 Pan Insert

FD018146



PRODUCT DETAILS

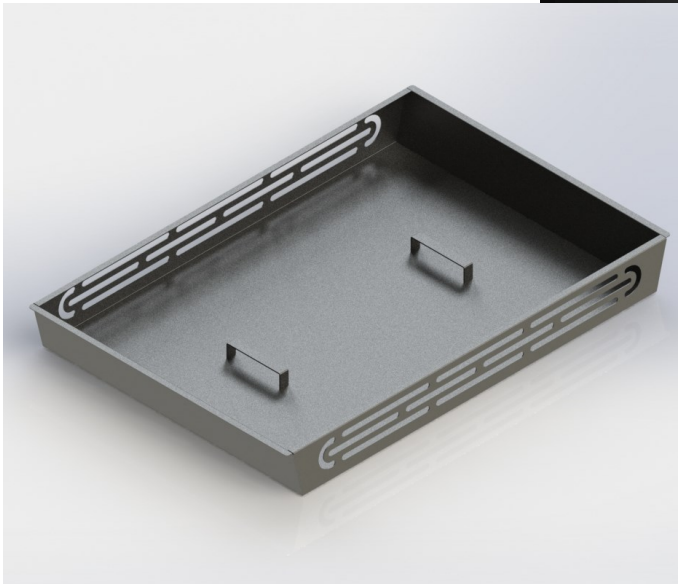

Function

- Fry Portioning Pan

Features

- Holds (12) 1/6th size pans
- Handles for easy removal and cleaning

FD018146

Dimensions: 3.12" H x 19.5" W x 28.56" D

Weight: 11lbs

FD018146 Fry Portioning Pan



PRODUCT DETAILS



Function

- **Front For Drawer Assembly**

Features

- **Insulated Drawer Front**
- **Magnetic Gasket**

FD018146

Dimensions: 10.75" H x 24" W x 1.875" D
Weight: 10lbs

FD018141-DF Drawer Front

FD016144



PRODUCT DETAILS



Function

- **Bottom Drawer Bulk Storage Pan**

Features

- **Convenient bulk fry storage**

FD016144

Dimensions: 6.625" H x 19.625" W x 23.81" D

Weight: 14lbs

FD016144 Bulk Storage Pan

FD016141



PRODUCT DETAILS

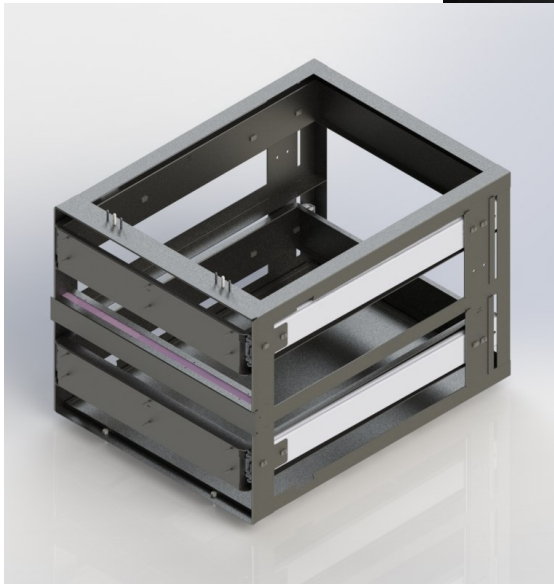

Function

- **Drawer Insert**

Features

- **(2) drawers for fry storage**
- **Large top drawer for portioning pans**
- **Heavy duty drawer slides**

FD016141

Dimensions: 19.62" H x 21.81" W x 29.25" D

Weight: 72lbs

***FD016141 Drawer Assembly
Insert***



PRODUCT DETAILS

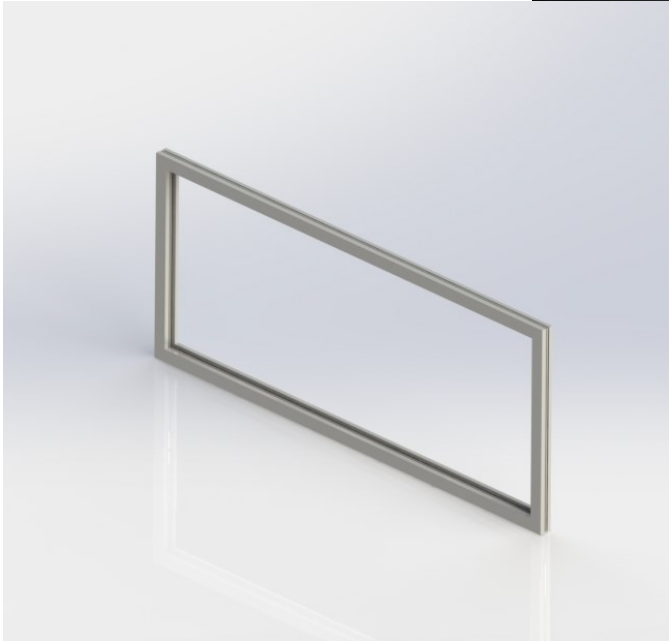

Function

- **Drawer Gasket**

Features

- **Magnetic**

7000272-14

Dimensions: 10.18" H x 23.75" W x .5" D

Weight: 1lb

7000272-14 Drawer Gasket

7000486-03320028



PRODUCT DETAILS



Function

- **28" Heavy Duty Drawer Slide**

Features

- **500lb capacity**

7000486-03320028

Dimensions: 3.18" H x .75" W x 28.18" D

Weight: 7lbs

**7000486-03320028 Heavy Duty
Drawer Slide**

7000732-13



PRODUCT DETAILS

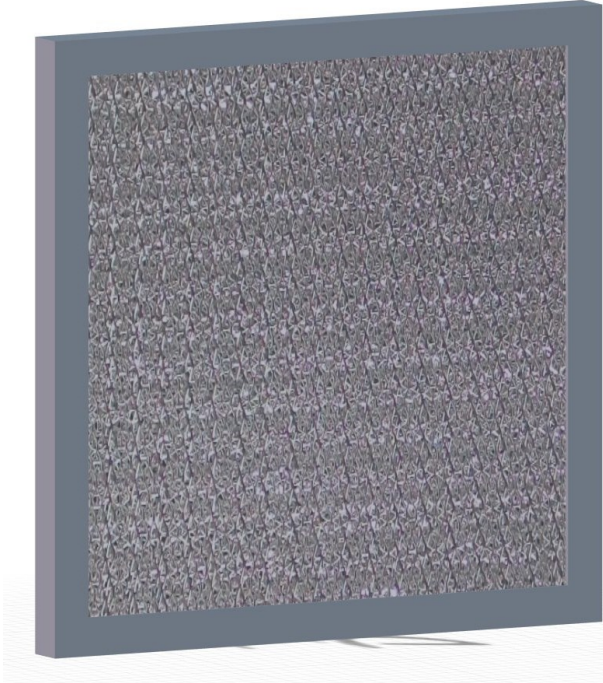

7000732-13

Dimensions: 13" H x 13" W x .5" D

Weight: .62lbs

Function

- **13"x13" Air Filter**

Features

- **Wire mesh design for easy cleaning**

7000732-13 13x13 Air Filter

7000015



PRODUCT DETAILS



7000015

Operating Voltage

- 120 volts, .1 amps

Function

- Refrigeration Temperature Control

Features

- Digital display
- Dual temperature probes

**MR4PMUHV-12 Johnson Controls
Temperature Control**

7000009



PRODUCT DETAILS



7000009

Function

- High Pressure Switch

Features

- SPDT type switch
- 100 PSIG to 400 PSIG Range
- 40 PSI to 150 PSI differential

**016-108 Ranco
High Pressure Control**

7000025



PRODUCT DETAILS



Operating Voltage

- 115 Volts, 5.3 Amps, 60 Hertz

Function

- 1/10 HP Compressor / Condensing Unit

7000025

**ASE12C4E-IAA-103 Copeland
Condensing Unit**

7000011



PRODUCT DETAILS



Function

- 1/4 ODF, 3/4 ODF Expansion Valve

7000011

***ACP1 Emerson
Expansion Valve***



PRODUCT DETAILS



Operating Voltage

- 120 volts, 3.5 amps

Function

- Evaporator coil

7000048-NOBRACKET

***BBL10AG Heatcraft
Evaporator Coil***

901692



PRODUCT DETAILS



Function

- Evaporator Drain Pan

901692

Dimensions: 4.43" H x 4.59" W x 16.64" D

901692 Evaporator Drain Pan

7000023-72



PRODUCT DETAILS



7000023-72

Operating Voltage

- 120 Volts, 2.5 Amps

Function

- Condensate Evaporator Pan

Pan and Power Cord can be purchased individually

T12-5000 Component Hardware
Condensate Evaporator Pan

7000733-180



PRODUCT DETAILS



Operating Voltage

- 120 Volts, .1 Amps

Function

- Drain Heating Wire

7000733-180

7000733-180 Drain Heater

7000737-330



PRODUCT DETAILS

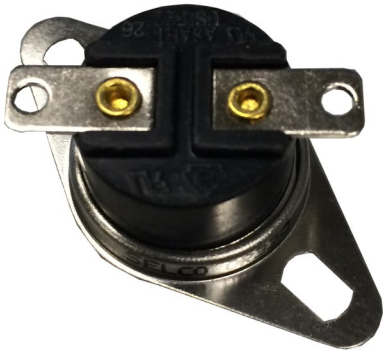

Function

- Safety Limit

Features

- 330° f setpoint
- Automatic reset

7000737-330

US-622
330° Snap Disc

7000737-400



PRODUCT DETAILS



Function

- Safety Limit

Features

- 400° f set-point
- Push to reset

7000737-400

**1NT08L-3663 Klixon
400° Snap Disc**

7000291-OYL



PRODUCT DETAILS



7000291-OYL

Operating Voltage

115 Volts, .1 Amp Operation

Function

- **Axial Fan**

**4600Z EBM-Papst
Axial Fan**

7000738



PRODUCT DETAILS



7000738

Function

- Solid State Relay

Features

- Green LED indicator
- Protective touch safe cover
- Built in MOV protection

***RM1A23D25 Carlos Gavazzi
Solid State Relay***



PRODUCT DETAILS



7000781-TEMPCO

Operating Voltage

- 120 Volts, 5.2 Amp, 625 Watt Operation

Function

- Heating Element For FD018124 Fry Lane Heating Insert

Features

- Finned casing for more efficiency
- 625 Watts of heating power

**CSF00747 Tempco
Heating Element**

7000786



PRODUCT DETAILS



7000786

Operating Voltage

- 100-240 Volts, 3 Watts

Function

- Temperature Control Unit

Features

- PID control
- Digital display screen
- 100ms High speed sampling
- Built in MOV protection

TC4SP-14R Autonics Temperature Controller

7000787



PRODUCT DETAILS

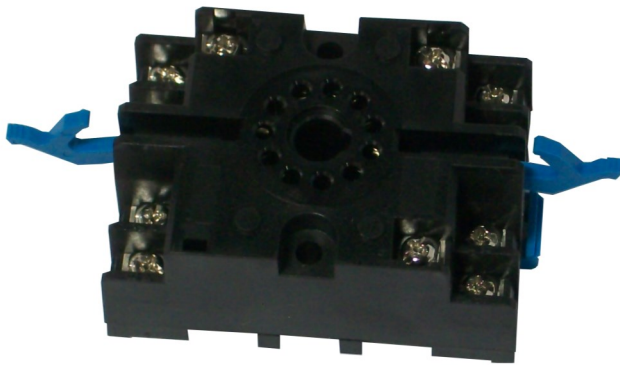

Function

- Socket For Temperature Controller

Features

- Din rail mounting system

7000787

***PS-11 Autonics
Temperature Control Socket***

7000796



PRODUCT DETAILS



Function

- Portioning Pan

7000796

Dimensions: 6" H x 6.87" W x 6.56" D

Weight: .94lbs

7000796 1/6th Size Pan

7000834



PRODUCT DETAILS

Function

- Temperature Probe

Features

- K type thermocouple



7000834

K Type Thermocouple



PRODUCT DETAILS

Operating Voltage

- **12 Volts DC, .13 Amps**



Function

- **(3) Lane Fry Timer**

Features

- **Breakfast, Lunch, and Dual Serve modes**
- **8 minute hold times**

FD018188

***TLT-3 Henny Penny
Timer***

7000748-2014



PRODUCT DETAILS



Operating Voltage

- 12 DC Volts, .2 Amps, 4 Watt Operation

Function

- LED Light Strip

7000748-2014

QS-AL-N-50CM
LED Light Strip

7000328-6



Operating Voltage

- 120 Volts, .23 Amps

Function

- Cooling Fan

7000328-6

**SA1725V1MBT Sofasco
Axial Fan**