

AC10-PC Refrigerated Liquid Dispensers



Service Manual

D-19-030RevA

Model	Products	Function	Button Panels	Weight	Dimensions	Capacity
AC10-PC	1	portion control	1, 3, 4, 5	60 lbs	17¾ x 9½ x 24	1 x 2½ gal (1 x 10 L)

NOTES: All Dimensions are in inches, with standard 1" legs installed.
 Power Supply – all dispensers: 120 VAC, 1 ph, 60 Hz, 3 amp

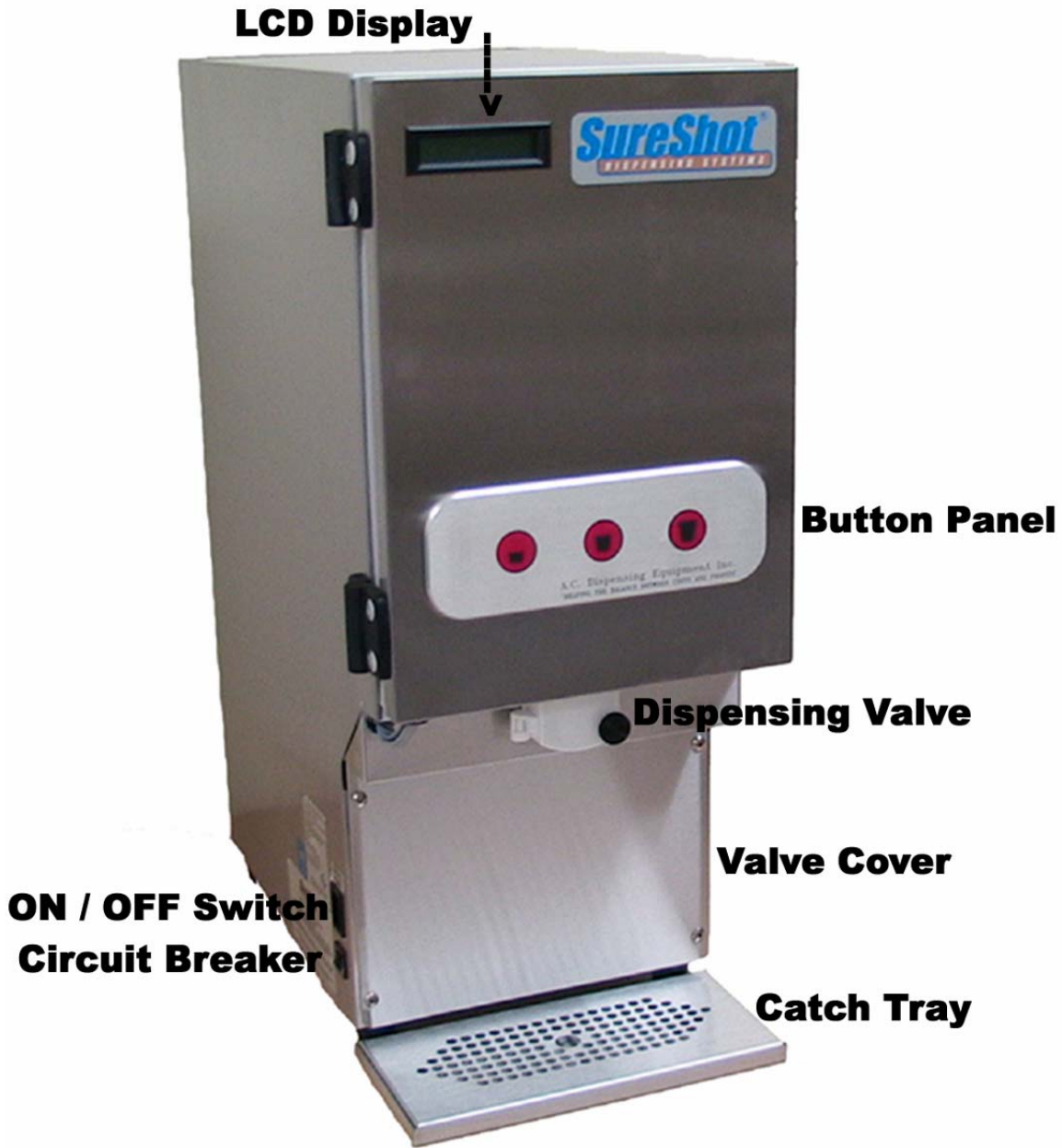

A.C. Dispensing Equipment Inc.
 100 Dispensing Way
 Sackville, Nova Scotia Canada
 B4C 4H2

Technical Assistance Center:
 1-888-777-9990 or 1-902-865-9602
 OR service@sureshotdispensing.com

Table of Contents

Dispenser Components	2	Remove & Replace Circuit Breaker	22
Specifications	2	Remove & Replace ON/OFF Switch	22
Safety Precautions	4	Remove & Replace Solenoid	23
Inspection for Damage	4	Remove & Replace Condenser Fan	24
Reshipment	4	Remove Back Panel	24
Uncrating the Dispenser	5	Replace Electrical Cord	24
Electrical Requirements	5		
Service – Electrical	5	6. CHECKS AND ADJUSTMENTS	
Service – Refrigeration	5	AC Outlet for 120 VAC	25
Installation of the Dispenser	5	AC 120 VAC input to Transformer	25
		AC 24/12 VAC output to PCB from Transformer	25
1. OPERATIONS		DC 2.8 → 3.8 VDC input of Valve Thermistor	26
Clean Before First Use	6	Resistance of Valve Thermistor	26
Starting the Dispenser	6	DC 2.8 → 3.8 VDC input of Display Thermistor	26
Loading the Dispenser	6	Resistance of Display Thermistor	26
Loading Product Bags	7	38 DVC output to Solenoid	27
To Remove an Empty Product Bag or Tank	8	38 DVC output to the Compressor Relay	27
To Dispense	8	120 VAC input to Compressor Back	27
Button Panels	8	Proximity Switch Continuity Check	28
Red Indicator Light	9	Quantity Volume Checks	28
LCD Display	9	To Adjust Dispense Amounts	28
		Displayed Temperature Offset Check	29
2. CLEANING		Displayed Temperature Adjustment	29
Recommended Cleaning Schedule	10	Gas Pressure Check	29
Cleaning – Catch Tray	10		
Cleaning – Valve Area	10	7. DIAGRAMS	
Cleaning – Exterior of Dispenser	10	Wiring Diagram	30
Cleaning – Dispensing Valve Area	11	Electrical System	31
Cleaning – Dispensing Valve Assembly	12	Circuit Board – labeled picture	32
Cleaning – Product Tanks & Caps	13	General Assembly	33
Cleaning – Product Case	13		
Cleaning – Refrigerated Compartment	13	8. PARTS LIST	34
Cleaning – Condenser	13		
3. REFRIGERATION SYSTEM	14	9. TROUBLESHOOTING	
Temperature Control Adjustment	14	Dispenser is not level	35
Dispenser Running Too Cold	15	No power at the plug	35
Dispenser Running Too Warm	15	Dispenser will not turn on	35
		Dispenser will not dispense product	35
4. MAINTENANCE		Dispenser is not dispensing proper amount of product	36
To Reset the Power on the Dispenser	16	Valve is sticky	36
General Maintenance	16	Valve door is broken	36
		Dispenser is warm on exterior	37
5. TECHNICAL SERVICE		Dispenser is warm on interior	37
Level Dispenser	17	Dispenser is too cold	37
Remove Valve Cover	17	Frost buildup in refrigeration compartment	37
Remove Dispenser Door	17	Dispenser is leaking product	38
Remove & Replace LCD Display	18	LCD does not come on	38
Remove & Replace Valve	19		
Remove & Replace Valve Thermistor	19	10. WARRANTY	39
Remove & Replace Display Thermistor	20		
Remove & Replace Circuit Board	20		
Remove & Replace Compressor Relay	21		
Remove & Replace Transformer	21		

Document # D-19-030 RevA



AC10-PC LIQUID DISPENSERS - OPERATIONS

The AC10-PC SureShot Dispensing Systems® Liquid Dispensers provide refrigerated liquids such as cream, whole milk, skim milk, in automatically controlled portions. Product selections are made using touch buttons on the front panel. Each button is pre-set independently at our factory to dispense a specified amount of refrigerated product in accurate, portion-controlled quantities to your company's specifications. The product is stored in a sanitary, refrigerated compartment within the dispenser.

The AC10-PC model will dispense a dairy product in up to five different sizes from touch buttons on the front of the dispenser.

Operating the dispenser is a simple two-step process:

1. Place cup under the product delivery tube.
2. Press button for the desired quantity of dairy product.

Safety Precautions

- Always plug the dispenser into an approved electrical outlet.
- The dispenser includes a microcontroller and must be operated on grounded electrical wiring at all times.
- Unplug the dispenser from its electrical source before servicing.
- Do not immerse the dispenser in water.
- Observe all safety precautions with this dispenser that you would with any electrical appliance.

INSPECTION FOR DAMAGE

When you receive the dispenser, inspect the exterior of the shipping container for damage. Note any damage in detail.

Uncrate the dispenser at once (see instructions below). Examine the dispenser for damage. Report any damage to the transportation company immediately. File a claim for damages promptly.

Your immediate inspection protects you against loss since A. C. Dispensing Equipment Inc. is not responsible for damages incurred during shipment.

RESHIPMENT

Packaging for re-shipment is done in the reverse order of uncrating. If packaging is not available, it can be purchased locally, or from our factory by request. Any damage occurring in transit of the returned goods caused by improper packaging is not considered a defect covered by Warranty.

NOTE: The Warranty will be null and void if the dispenser is serviced by unqualified personnel. Service under Warranty must be approved and dispatched by A. C. Dispensing Equipment Inc. before the service technician is dispatched. Contact the SureShot Dispensing Systems® Technical Assistance Center at 1-888-777-9990 or 1-902-865-9602 for approval. The customer is responsible for all costs not approved by A. C. Dispensing Equipment Inc.

UNCRATING THE DISPENSER

CAUTION: Always lift the dispenser from the bottom. Do **not** lift the dispenser by the door.

To uncrate:

1. Make sure the box is positioned with the arrow pointing upward.
2. Cut the packing straps at the top of the box.
3. Lift the top tray off the box.
4. Lift the center sleeve off the box.
5. Remove the protective corner inserts from the bottom tray.
6. Lift the dispenser by its bottom out of the tray. Always use two people to lift the dispenser.
7. Remove the plastic protective covering from the stainless steel exterior of the dispenser, by peeling it off. To peel, hold the dispenser firmly at the top and peel from top to bottom.
8. Prior to use, read the Operations Manual. Store it for future use.

NOTE: The carton top, sleeve, and bottom tray may be stored for future shipping.

ELECTRICAL REQUIREMENTS

Be sure the current at the power source receptacle is: 120 VAC, single phase, 3 Amp, 60 Hz.

The power cord is furnished with a UL-approved 3-prong attachment plug. This plug is designed to fit a receptacle with provisions for a grounding stud. The dispenser includes a microcontroller and must be operated on grounded electrical wiring at all times. Failure to do so will void the Warranty.

SERVICING - ELECTRICAL

Electrical servicing must be carried out by a qualified technician. The Warranty will be null and void if the dispenser is serviced by unqualified personnel. If you need assistance, call the SureShot Dispensing Systems® Technical Assistance Center at 1-888-777-9990 or 1-902-865-9602.

SERVICING - REFRIGERATION

Any servicing of the refrigeration system must be carried out by a qualified technician. The Warranty will be null and void if the refrigeration system is serviced by unqualified personnel. If you need assistance, call the SureShot Dispensing Systems® Technical Assistance Center at 1-888-777-9990 or 1-902-865-9602.

INSTALLATION AND LOCATION OF THE DISPENSER

1. Location of Dispenser:

- Place the dispenser where it will best serve your operation.
- Counters, platforms, or shelves should be strong enough to support the dispenser and full containers of product. The empty AC10-PC dispenser weighs 60 pounds.
- Place the dispenser at the appropriate serving height so that people drawing product from the dispenser can operate the buttons as well as easily place and remove cups.
- Leave clear space around the dispenser, approximately 1 inch (2.5 cm) on all sides.
- Do not place the dispenser too close to a source of heat or moisture. Allow a minimum 1 inch (2.5 cm) airspace between machines at all times. The performance and efficiency of the refrigeration system will be reduced if the dispenser is placed too close to a heat-generating machine, such as a coffeemaker.
- Do not block the vents at the top rear of the dispenser. The vents **must** be free and open to ensure proper operation of the ventilation system and to prevent over-heating and damage to the system.
- The dispenser **must** be placed on a level surface or leveled by adjusting the legs. Not all dispensers have adjustable legs. The dispenser must be level, left to right and front to back, to dispense accurate quantities and to ensure proper functioning of the refrigeration system.
- Do not remove the legs or rubber feet from the dispenser or allow the dispenser to sit flat on the counter. Airflow and circulation under the machine are essential for the proper operation of the refrigeration system. Make sure the legs at the four corners of the bottom of the dispenser are in place. If one has loosened during shipping, re-tighten it. Some dispenser models have adjustable legs and these legs are secure even though they may appear to be loose. Removal of the legs automatically voids the Warranty.

1. OPERATIONS

CLEAN BEFORE FIRST USE OF THE DISPENSER

- Make sure you clean the dispenser thoroughly. See Cleaning Instructions for the Exterior of the Dispenser and the Dispenser Components on pages 10 - 13.

CAUTION: Before starting the dispenser, make certain that all Installation instructions have been followed and that the dispenser has been sitting upright for a minimum of 3 hours.

STARTING THE DISPENSER

To start the dispenser:

1. Plug the power cord into the proper electrical outlet.
2. Turn the Power Switch "ON". The power switch is located at the lower left of the dispenser. Make sure the dispenser door is closed. Push one of the product buttons on the front panel and listen to hear the valve open and close. This confirms that the dispenser is operating. The button panel on the front of the dispenser may have a power LED which glows green when the dispenser is on.
3. Allow the dispenser to run empty for one hour to achieve a cold temperature before placing product containers in the dispenser. The temperature control has been pre-set at the factory. You can feel the cold temperature by placing your hand on the top or back wall of the refrigeration compartment.
4. If the dispenser does not appear to be getting cold, check to make sure that it is plugged in and that the power source is active. If the dispenser still does not operate, immediately call the SureShot Dispensing Systems® Technical Assistance Center Technical Assistance Center at 1-888-777-9990 or 1-902-865-9602.

LOADING THE DISPENSER

- Ensure the dispenser has achieved proper operating temperature by running empty for one hour before loading product to be dispensed.
- Product being placed inside the refrigeration compartment should be cooler than 41 °F or 5 °C.
- The product is supplied in sanitary pre-packaged bags with attached delivery tubes. The bags are placed in product cases that are placed within the refrigeration compartment.

LOADING: Product Bags

NOTE: Product may be loaded in bags, bags in boxes, or in tanks.

- All product tanks must be cleaned properly, sanitized with an approved sanitizing solution according to the manufacturer's specifications, and air-dried before they are loaded into dispensers. Follow cleaning instructions on page 13.
- Tanks are to be loaded into the dispenser with the power switch ON.
- Tanks should be filled with chilled product before they are loaded into the dispenser. Fill to the FULL level with product chilled to 41 °F (5 °C) or less.
- Sanitize your hands or wear clean gloves to install product tank, tank cover, and delivery tube.

Sanitize your hands or wear clean gloves to load the dispenser.

1. Place the bagged product in the product case provided with the dispenser. Make sure the bag fitment is positioned so the product delivery tube is inserted through the opening at the bottom front of the case and is perpendicular to the dispensing valve.
2. Open the door to the refrigerated product compartment.
3. Open the valve door by unscrewing the black knob in a counter-clockwise motion to loosen the screw.
4. Insert the product case into the refrigerated product compartment, with the tube facing out to the front.
5. Make sure there are no kinks or twists in the product delivery tube.
6. Remove the polyethylene film covering the product delivery tube.
7. Align the product delivery tube in the central vertical groove of the valve block.
Do not pull or stretch the product delivery tube.
8. Close the valve door, making sure the product delivery tube is in the vertical groove and is not kinked or pinched.
9. While holding the valve door closed with one hand, tighten the knob-screw in a clockwise motion until the door is snug.
Do not over- tighten the screw.
10. Close the refrigerated product compartment door.
11. Squeeze the product delivery tube just below the valve with all fingertips.
12. While squeezing the tube, press the "small" product quantity button on the front door button panel **once** only. This will cause the valve to operate once and relieve pressure in the tube.
13. Use sharp scissors or a sharp knife to carefully cut the product delivery tube at a 45° angle at a maximum length of 5/8" from the bottom of the valve block.
Discard the cut portion of the tube.

The dispenser is ready for use.



Loading product bag



Tube alignment

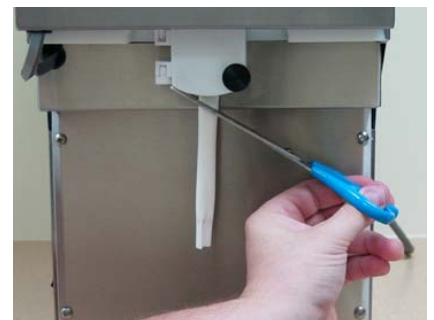

Cut tube

To Remove an Empty Product Bag or Tank:

1. Place a container under the dispensing valve to catch any residual product and to prevent spills.
2. Open the valve door by unscrewing the knob in a counter-clockwise motion.
3. Remove the empty bag or tank while pinching the product delivery tube so that it does not drip. Discard the empty product bag.
4. EMPTY TANK: Wash, rinse, sanitize and air-dry the product tank, using cleaning instructions on page 13.

OPERATING INSTRUCTIONS – AC10-PC Dispensers

- Make certain all initial Set-Up instructions have been followed before operating the dispenser.
- The product and volume to be dispensed are selected by pressing buttons on the Button Panel on the front door of the dispenser.
- Select buttons as required.

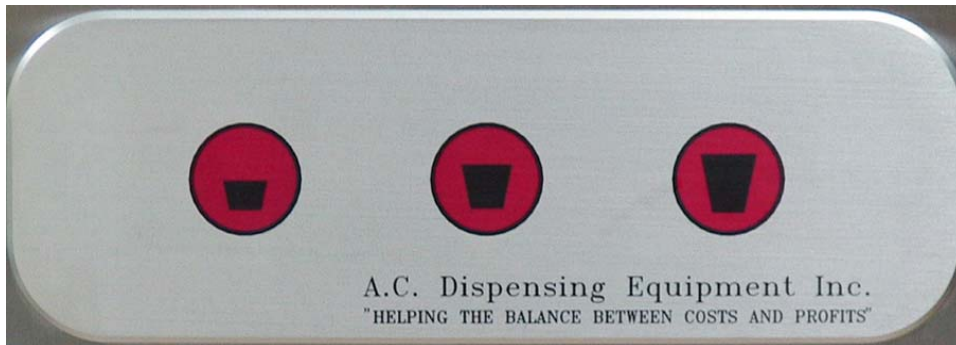

To Dispense Product:

1. Place cup under product delivery tube.
2. Press button to select product quantity to be dispensed.

BUTTON PANEL

Select the size button for the quantity to be dispensed.



One Size



Three Sizes: 1 2 3
 small medium large



Four Sizes: Small Medium Large X-Large

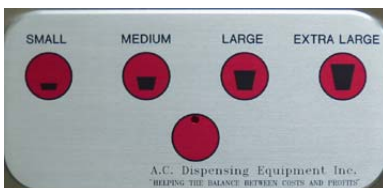

Five Buttons:

Four Sizes: TOP: Small Medium Large X-Large
 BOTTOM: Modifier Button

1. Press Modifier Button to dispense quantities for modifier amounts
2. Press top row button to select size of product dispensed

RED INDICATOR LIGHT

Some dispensers have a 5-button panel. The bottom row button is a Modifier Button for dispensing quantities for specialty Modifier amounts. The Modifier Button has a Red Indicator Light (red LED) at the top.

The Indicator Light will light for three seconds after the Modifier Button is pressed, to indicate that the size selected will be dispensed in Modifier amounts.

The Indicator Light will flash to indicate the Modifier Button is in program mode (see page 28).

LCD DISPLAY – AC10-PC Dispensers

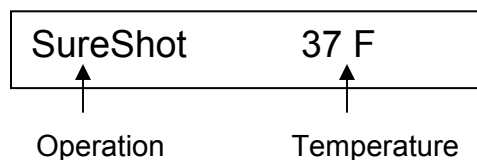

SureShot Dispensing Systems® liquid dispensers use a Liquid Crystal Display in the upper left corner of the dispenser door to show the current dispenser function.

Note: not all dispensers have an LCD.

Information is displayed in two parts:

Operation – shows the current operating function of the dispenser

Temperature – shows the internal temperature of the refrigeration compartment. (NOTE: this is the compartment temperature in Celsius or Fahrenheit degrees, not the product temperature.)

Temperature:

Continuously shows the internal temperature status of the refrigeration compartment in Celsius or Fahrenheit degrees, at your company's specifications. The display changes every 3 seconds.

Examples:

37 F	37 degrees Fahrenheit
(blank)	refrigeration system off
★	refrigeration system on
DEF	defrost cycle in progress

Operation:

Press the button to Select Product. The LCD shows the operational status of that product tank or case:

Display	Operational Status
SureShot 37 F	indicates the dispenser is ready to dispense and the internal compartment temperature is 37 °Fahrenheit
TR1	If the valve door is opened and closed, the dispenser resets the product level for the case or tank dispensed by that valve. This display shows that the level has been reset to Full for the tank/case.
Small Medium Large Extra Large	Indicates the size selected, if Size button is pressed. The LCD displays the size to be dispensed to your company's specification. Not all dispensers have the Extra Large option.

NOTES:

- Display returns to SureShot, the default display, after 3 seconds.

2. CLEANING

- **Cleaning of tanks is a 4-stage process: Rinse, wash, rinse, sanitize. All 4 stages must be followed, in sequence, to complete cleaning.**

Do not spray any liquid, such as a cleaner, in or around the valve area.
Liquid could damage electrical components located behind the valve.

RECOMMENDED CLEANING SCHEDULE:

DISPENSER PART	FREQUENCY	SEE PAGES
Catch Tray	Daily	10
Exterior	Daily	10
Valve area	Daily	10
Exterior	Daily	10
Dispensing valves - PC	Once a month, or as needed	11, 12
Product Case	Every time valve is cleaned, or as required	13
Refrigerated Product Compartment	Every time a new product bag or tank is loaded	13
Condenser	Every 6 months	13

CLEANING: Catch Tray

Note: Not all dispensers have a catch tray.

For some dispensers, the catch tray is a separate accessory placed at the front of the dispenser.

For some dispensers, the catch tray is attached at the front and must be removed for cleaning, by lifting it up and off.

1. Rinse the tray with lukewarm potable water.
2. Place the tray in a hot water wash at a minimum water temperature of 140 °F or 60 °C.
 - A good quality general cleaner should be added to the hot wash water at the concentrations recommended by the detergent supplier.
3. Wash thoroughly, using a bottle brush to reach all the corners and crevices.
 - If a dishwasher is available at the location, this step may be carried out by placing the tray in the dishwasher and washing on the pot cycle.
4. After washing, rinse the tray well with lukewarm potable water.
5. Turn the tray upside down. Air dry.

CLEANING: Valve Area

1. Turn the dispenser OFF.
2. Open the door to the refrigerated product compartment.
3. Thoroughly wipe the area around the valve with a warm, soapy cloth or a sanitized handwipe to remove any splashes or product build-up.
 - Keep the valve area clean for proper sanitation and to ensure proper product delivery.
 - If the valve area is not clean, the valve may stick and not deliver product accurately.
 - Clean the valve assembly once a week, when the tank is empty.
 - Wipe the valve area clean daily.
4. Wipe the area with a damp cloth to remove any soap residue.
5. Air dry thoroughly.
6. Close door to refrigerated product compartment.
7. Turn the dispenser ON.

CLEANING: Exterior of Dispenser

NOTE: Do not use any abrasive materials.

1. Use a soft, dry cloth to wipe down the exterior surfaces of the dispenser to maintain the lustre of the stainless steel finish.
2. Wash the stainless steel exterior surfaces of the dispenser with warm, soapy water.
3. Rinse with warm clear water.
 - If the water is hard, wipe the dispenser dry with a soft cloth to prevent water spotting.
 - Stainless steel polish may be used if it is sprayed on a cloth before the cloth is used to wipe down the exterior surfaces of the dispenser.
 - The front of the dispenser should be wiped clean **daily**.

CLEANING: Valve Area & Valves – Portion-Controlled Dispensers

- The area around the product delivery valve must be kept clean, for proper sanitation and for the proper delivery of calibrated product amounts. If the valve area is not clean, the valve may stick and not deliver product accurately, or at all.
- The area around the product delivery valve should be wiped clean daily.
- It is necessary to remove the valve from the dispenser and take the valve apart to clean it (we recommend once a month or as needed), but it is an easy process if you follow the steps outlined on the following pages.

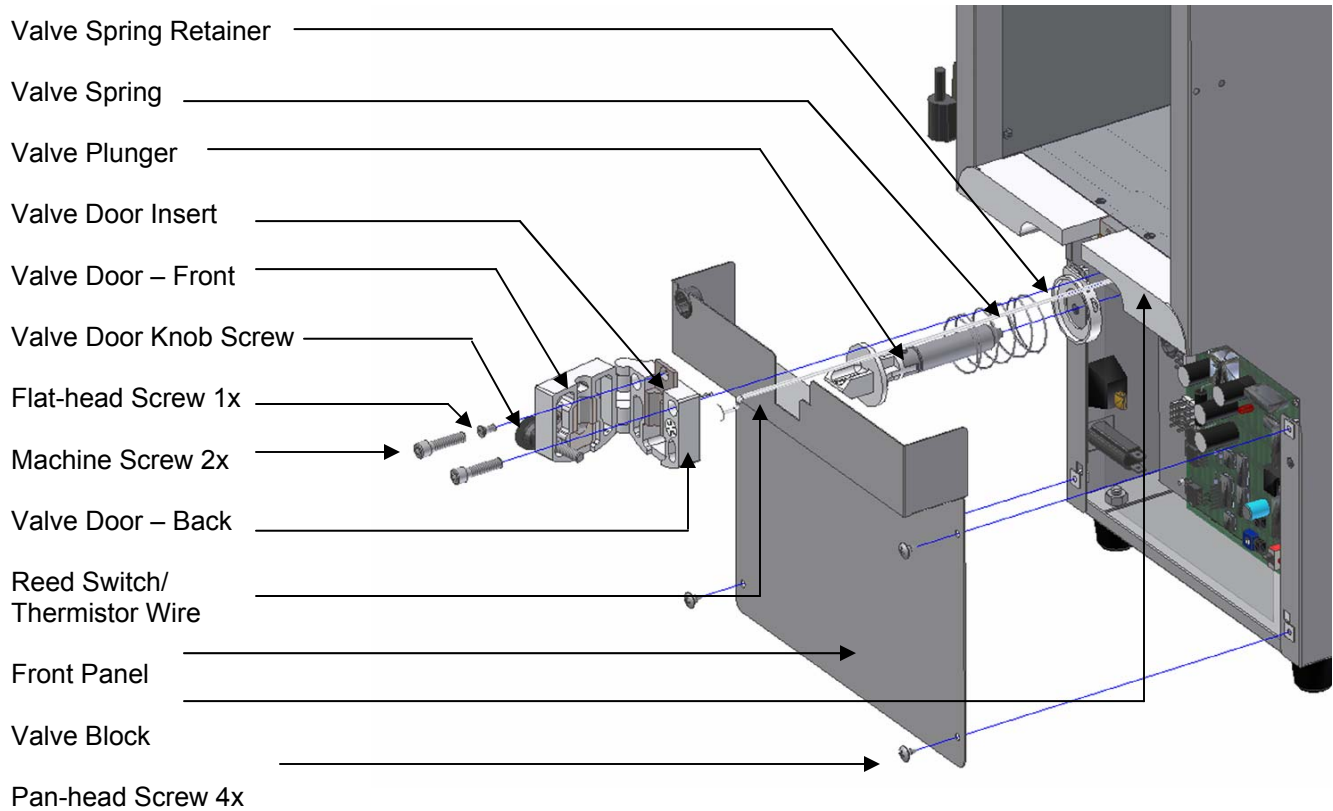

Valve Assembly

CLEANING: Remove & Clean Dispensing Valve Assembly

**NOTES: Prepare a container of warm, soapy water before you take the valve apart for cleaning.
Be careful not to dislodge the cable during cleaning.**

1. Turn the power to the dispenser OFF.
2. Open the dispenser door to the refrigerated product compartment.
3. Remove the product tanks by following the instructions on page ____.
4. Remove the catch tray (if applicable) by lifting it up and off.
5. Remove the 4 pan-head screws (+) that secure the front splash panel (valve cover) in place and carefully remove the panel. It is located below the white plastic valves that hold the product dispensing tubes. It is held in place by 4 phillips-head screws (+).
Thoroughly wash the splash panel.
6. Open the valve door: unscrew the black knob in a **counter-clockwise** motion.
7. Remove the phillips-head screw at the top of the metal valve insert. **Do not misplace the screw.** Wipe clean.
8. Remove the 2 phillips-head screws at the upper corners of the valve block. **Do not misplace the screws.** Wipe clean.
9. Gently remove the white valve body, using an even force.
Hold the valve carefully with one hand so that the thermistor wire will not be broken or damaged.
Do not let the valve dangle freely. Hold it in your hands.
NOTE: The valve body can only be moved the length of the thermistor wire.
10. Remove the plunger and spring.
Rinse, wash, rinse, sanitize, and air dry the plunger and the spring
11. Wipe the spring cup clean.
12. Clean the white plastic sections of the valve block, using a small brush with warm, soapy water.
Rinse, sanitize, and air dry the white plastic sections of the valve block with the plunger and spring. **Air dry thoroughly.**
13. Reassemble the spring, the plunger, and the valve body.
14. Align the valve body with the plunger. Move back into place.
15. Replace the 2 phillips-head screws. Tighten until snug.
Do not over-tighten the screws.
16. Replace phillips-head screw at the top of the metal valve insert.
This screw must fit snugly to ensure proper operation of the refrigeration system. **Do not over-tighten the screw.**
17. Close the valve door.
18. Secure the door by tightening the knob-screw in a **clockwise** motion until the door is snug. **Do not over-tighten the screw.**
19. Re-install 4 phillips-head screws to secure the front panel in place.
20. Wipe the product compartment clean.
21. Close the refrigerated product compartment door.
22. Turn dispenser ON.
23. Push any "size" button.
Listen for the valve door open and close to ensure that the valve is operating properly.
24. Load new product and dispense.

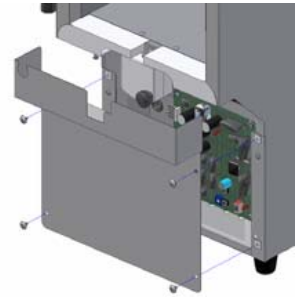

Step 5

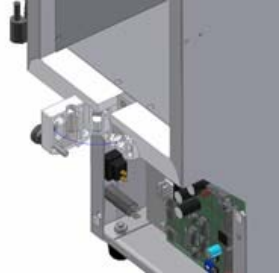

Step 6

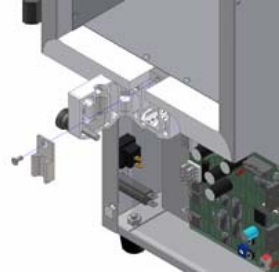

Step 7

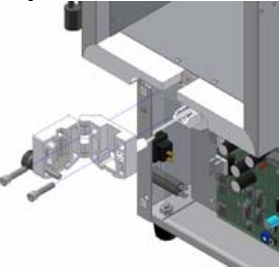

Step 9

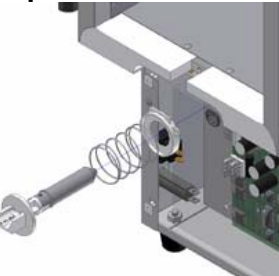

Step 10

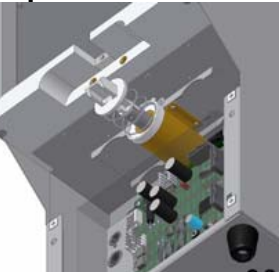

Step 13

CLEANING: Product Tanks and Caps

Product tanks and covers are made of either stainless steel or plastic. Tanks and caps may be washed in a dishwasher or by hand according to provincial and state regulations. If washing by hand, a pot brush is recommended.

Product tanks must be washed and sanitized in a dishwasher or by hand every time the tank is removed from the dispenser and placed in the dispenser. Cleaning requirements may be specified by company policy or local regulation. Comply with their specifications.

To clean the product tank:

1. When the product has run out, remove the tank from the dispenser. Remove the product delivery tube from the tank.
Discard the tube.
Rinse the tank, including the cover, with lukewarm potable water.
2. Place the tank and cover in a hot water wash at a minimum water temperature of 140 °F or 60 °C.
 - A good quality general cleaner should be added to the hot wash water at the concentrations recommended by the detergent supplier.Wash thoroughly, using a bottle brush to reach all the corners and crevices.
Wash the outlet spout area, using a small bottle brush.
 - If a dishwasher is available at the location, this step may be carried out by placing the tank and cover in the dishwasher and washing on the pot cycle.
3. After the tank and cover have been washed, rinse well with lukewarm potable water.
4. Turn the tank and cover upside down. Air dry.
5. Before refilling the tank with product, sanitize the tank and cover with mild sanitizer such as chlorine at 100 ppm, or a product recommended by your detergent supplier.
Let the tank and cover drain before filling with product. Do not rinse.
6. Just before filling the tank, apply a new white dairy tube to the outlet spout of the tank.
7. The tank may be pre-filled before it is required, but the tank and contents must be stored, with the cover on, in a refrigerator until placed in the dispenser.

CLEANING: Product Case

Product cases hold the pre-bagged product. The cases are made of a metal front, back, and bottom, with plastic sides. Cases must be washed by hand according to provincial or state regulations. When washing by hand, a pot brush is recommended.

Make sure the case is cleaned each time the valve is cleaned, or more frequently, if required.

To clean the product case:

1. Remove the product case from the refrigeration compartment of the dispenser.
2. Wash with hot, soapy water or an approved sanitary cleaning product, according to provincial or state regulations.
3. Rinse with hot, clear water to remove soap residue.
4. Dry thoroughly.

CLEANING: Refrigerated Product Compartment of Dispenser

Wipe the compartment clean each time a new product bag or tank is loaded. This will remove any condensation that may accumulate within the compartment.

1. Each time a new product bag or tank is loaded, check the refrigerated product compartment for ice build-up. If ice has accumulated in the refrigerated product compartment, gently remove and discard the ice. It will be easier to remove ice if you turn the dispenser off for 10 – 15 minutes.
2. Wipe the interior down with a soft cloth
3. Dry thoroughly.

CLEANING: The Condenser

Every 6 months, remove the back panel of the dispenser and inspect the condenser. If necessary, clean the condenser using a vacuum, to prevent any damage to the condenser coil.

3. REFRIGERATION SYSTEM AND TEMPERATURE ADJUSTMENT

REFRIGERATION SYSTEM

- The refrigeration system is a hermetically sealed system which uses environmentally friendly **R134-A refrigerant**.
- If recharging of the system is required, the refrigeration technician should refer to the A. C. Dispensing Equipment Inc. Machine Identification Label located on the left side of the dispenser for details on the quantity of refrigerant used.
- The condenser is located at the rear of the dispenser behind the back panel.
- The evaporator is incorporated within the stainless steel walls of the refrigerated product compartment, i.e. cold-wall evaporation system.
- The compressor is located below the storage compartment and is accessible through the back panel.

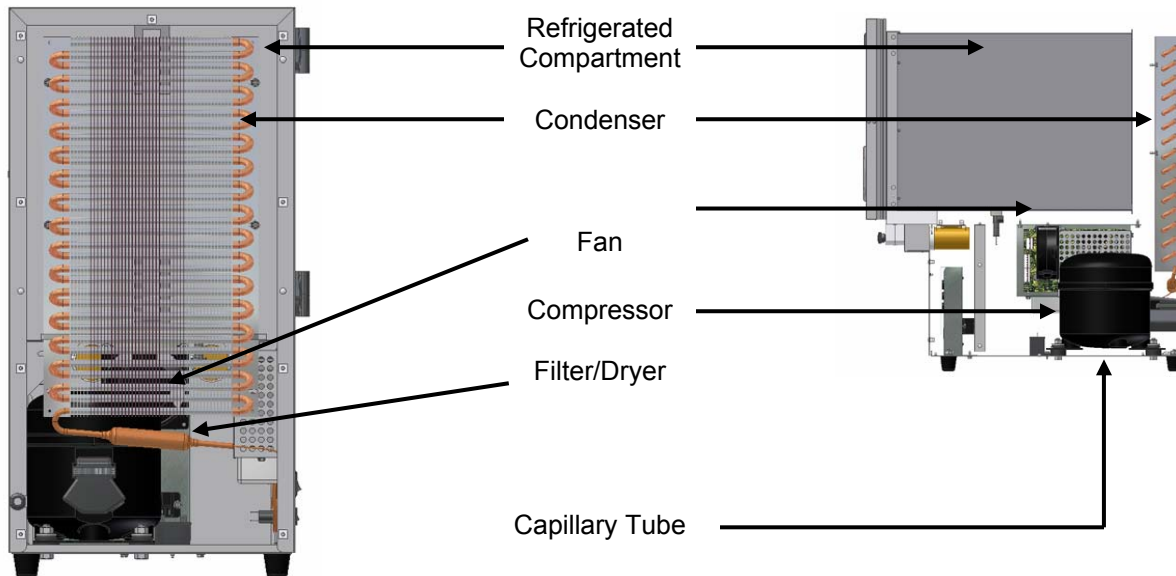

TEMPERATURE CONTROL ADJUSTMENT

Each SureShot Dispensing Systems® dispenser is pre-set at our factory to meet your operating standards. These settings should not require adjustment.

The temperature in the refrigerated product compartment is set at our factory for normal use in the North American food service industry. The temperature is set to maintain the product within the range of 35 °F to 40 °F (1.6 °C to 4.4 °C). The temperature is controlled by an adjustable thermostat. The adjustment pot for this thermostat is located at the middle of the right side of the circuit board. (See page 15)

1. Open the door to the refrigerated product compartment.
2. Remove the 4 pan-head screws that secure the front splash panel/valve cover in place and carefully remove the front splash panel/valve cover. It is located below the white plastic valves that hold the product tubes. It is held in place by 4 Phillips screws (+).
3. When this cover is removed, locate the Circuit Board that has electronic components on it. A red LED light should be (ON) indicating that there is power supplied to the board.
4. Locate the Temp. Adj. (R36 - Temperature adjustment) Pot, which is on the middle bottom of the circuit board. It is a blue plastic square, approximately ½” square. It has a white circular center with a slot.
5. From the factory, this Temp. Adj. slot adjustment would have been set vertical (at 12 and 6 o'clock if you were to compare it to hands on a clock).
6. Follow the instructions on page 15 for adjustments, depending on whether your dispenser is running too cold or too warm.

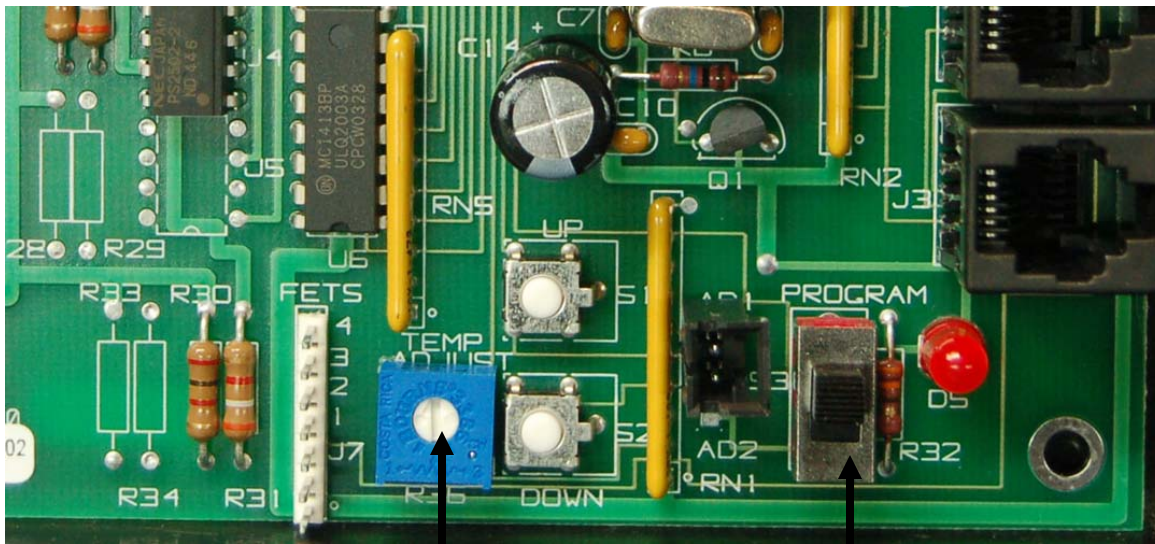
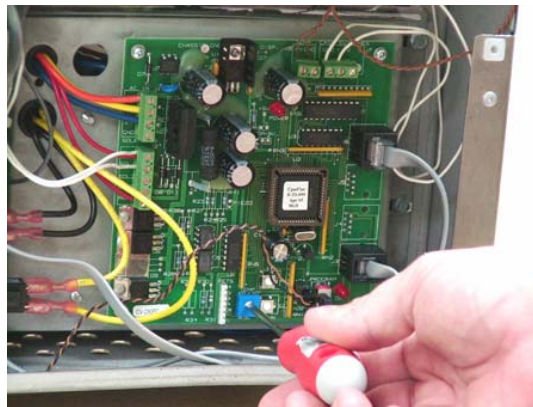

Temperature Adjust R 36

Program

If The Dispenser Is Running Too Cold:

To increase the temperature or to make it warmer, turn the white center slot left or counterclockwise 1 hour to 11 o'clock. Allow this adjustment to take effect for 3 hours.

If still not warm enough, adjust the Temperature Adjust to 10 o'clock and repeat the wait time. You can further adjust the temperature to 9 o'clock. Do **not** adjust further.

If, after these adjustments are made, your unit is still running too cold, please call SureShot Dispensing Systems® Technical Assistance Center at 1-888-777-9990 or 1-902-865-9602 during your 1-year warranty period or a qualified Refrigeration Technician after your warranty period has expired.

If The Dispenser Is Running Too Warm:

To decrease the temperature or to make it colder, turn the white center slot right or clockwise 1 hour to 1 o'clock. Allow this adjustment to take effect for 3 hours.

If still not cold enough, adjust the Temperature Adjust to 2 o'clock and repeat the wait time. You can further adjust the temperature to 3 o'clock. Do **not** adjust further.

If, after these adjustments are made, your unit is still running too warm, please call SureShot Dispensing Systems® Technical Assistance Center at 1-888-777-9990 or 1-902-865-9602 during your 1-year warranty period or a qualified Refrigeration Technician after your warranty period has expired.

4. MAINTENANCE

To Reset the Power on the Dispenser:

1. Locate the Power Control ON/OFF switch on the front left of the dispenser.
2. Turn **OFF** the Power Control ON/OFF switch.
3. Locate the 3 Amp circuit breaker above the Power Control on/off switch.
4. Depress the 3 Amp circuit breaker to make sure it has not popped.
 - No white should be showing. If white is showing on the top of the breaker, it is tripped.
 - It will make a clicking noise when depressed.
5. Turn back **ON** the Power Control ON/OFF switch.

General Maintenance

- Gently remove ice build-up, if any ice forms. Ice build-up could indicate an improper temperature setting or an improperly sealed door.
If the dispenser has accumulated ice or frost at the top of the refrigerated product compartment, it is best to remove it by hand during a defrost cycle, which runs automatically and will be indicated on the LCD display panel (DEF). Forming ice does not necessarily mean the temperature of the product is too cold.

Ice may be removed during a product change: unplug the dispenser. Leave the door open for about 15 minutes to allow the ice to soften. Remove the ice by hand.

If a temperature adjustment is required, follow the instructions on page 15. If further assistance is required, contact the SureShot Dispensing Systems® Technical Assistance Center at 1-888-777-9990 or 1-902-865-9602.

- If you have difficulty closing the door, check for ice buildup and remove to ensure proper operation.
- Check the door gaskets, to ensure there are no cuts or gaps. The door must close tightly to ensure proper refrigeration.

Check the operation of the fan, being careful not to cut or injure fingers. The fan is located on the right side of the dispenser, behind the front panel (See page 14). If the fan is not operating, call SureShot Dispensing Systems® Technical Assistance Center at 1-888-777-9990 or 1-902-865-9602 for assistance.

Caution: Keep the dispenser level at all times. Do not tip the dispenser while it is operating. Tipping will damage the compressor and prevent proper operation of the refrigeration system.

5. TECHNICAL SERVICE

Leveling Dispenser

- The dispenser **must** be placed on a level surface or leveled by adjusting the legs. The dispenser must be level to dispense accurate quantities and to ensure proper functioning of the refrigeration system. Not all dispensers have adjustable legs. Some models have plastic feet, which are not adjustable.
- Do not remove the legs or feet from the dispenser or allow the dispenser to sit flat on the counter. Airflow and circulation under the machine are essential for the proper operation of the refrigeration system. Make sure the legs or feet at the four corners of the bottom of the dispenser are in place. Some dispenser models have adjustable legs and these legs are secure even though they may appear to be loose. If one has loosened during shipping, re-tighten it.
- Removal of the legs automatically voids the Warranty.

1. Place the dispenser on the countertop.

2. Level the dispenser:

For dispensers with plastic feet: level the countertop.

For dispensers with adjustable legs: Adjust the legs by hand-turning them slightly until the dispenser is level.

- To ensure the dispenser is level, place a bubble level on the top of the dispenser to guide you during the adjustments.
- Do not allow the dispenser to be tilted backwards.



Level – left to right



Level – front to back

Remove Valve Cover

1. Remove the 4 Phillips screws holding the cover in place.
2. Pull the cover down and out.

Remove Dispenser Door

1. Turn the power switch OFF.
2. Remove the lower valve cover, by removing the 4 screws.
3. Unplug the door cord(s) – one or two cords, depending on the dispenser model.
4. Remove the ground wire.
5. Firmly grasp the dispenser door with two hands and lift the door straight up
6. Replace the door, using steps in the reverse order of the removal.
7. Turn the power switch back ON.



Step 1



Step 2



Step 3

Remove & Replace LCD Display

1. Turn the power switch OFF.
2. Open the dispenser door.
3. Lift the inside door gasket to expose the 10 hex-headed screws.
4. Remove the steel back panel from the door by removing the 10 screws.
5. Identify the display: it will be located under a piece of tape.
6. Lift the tape – do not discard tape.
7. Unplug the old Display Connector from the 10-Pin Header.
8. Remove the old Display.
9. Install and plug in the new display.
10. Place tape back over the display. Use UL-approved tape to completely cover the display back.
11. Re-install the steel back panel and gasket by replacing the 10 screws.
12. Restore the inside door gasket.
13. Install and close the dispenser door.
14. Turn the power switch back ON.



Step 3



Step 4



Step 5



Step 6



Step 7



Step 8



Step 9



Step 10



Step 11

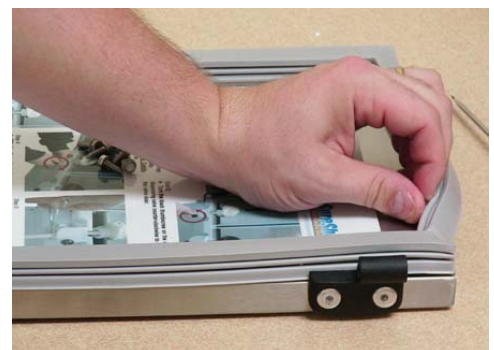

Step 12

Remove & Replace Valve

To Remove & Clean Valve Assembly – See Operations – Cleaning Valve, page ____ OR

1. Turn the power switch OFF.
2. Remove the valve cover by removing the 4 Phillips screws.
3. Open the valve front and remove the 3 Phillips pan-head screws.
4. Gently pull the valve forward. Be careful to extract any wires along with the valve.
5. Disconnect all wires from Circuit Board.
6. Pull the aluminum insert forward from the back of the valve. If wires are attached to the aluminum insert, pull these along with the insert when extracting.

NOTE: to resume use of the dispenser, you must replace the valve, following the reverse order of steps and then turn the power switch back ON.



Step 3



Step 4



Step 6

Remove & Replace Valve Thermistor

1. Turn the power switch OFF.
2. Remove the valve cover – remove the 4 Phillips screws.
3. Open the valve front - remove the 3 Phillips pan-head screws.
4. Gently pull the valve forward.
Be careful to extract any wires along with the valve.
5. Disconnect all thermistor wires from the Circuit Board.
6. Pull the aluminum insert that contains the thermistor forward from the back of the valve.
7. Replace the valve thermistor following the reverse order of steps.
8. Replace the valve cover.
9. Turn the power switch back ON.



Step 5

Remove & Replace Display Thermistor

1. Turn the power switch OFF and unplug dispenser.
2. Remove the valve cover – remove the 4 Phillips screws.
3. Locate and disconnect the 2 grey and black wires (or 2 black wires) coming from AD1 connector found at the lower right corner of the circuit board.
4. Follow the 2 wires back and locate the screw in the Display Thermistor.
5. Turn the lower section of the Display Thermistor counter-clockwise and extract.
6. Replace the Display Thermistor. Make sure it is tightened snugly by hand for proper contact to inner box.
7. Reconnect to Circuit Board
8. Replace the valve cover.
9. Plug in the dispenser.
- 10 Turn the power switch back ON.

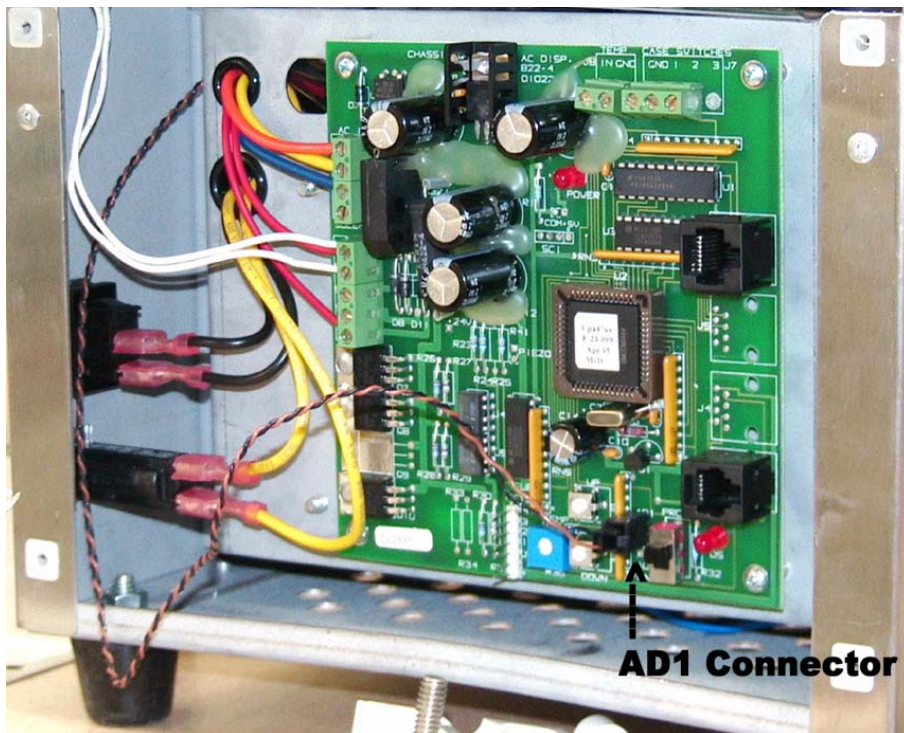

Step 3

Remove & Replace Circuit Board

1. Turn the power switch OFF and unplug dispenser.
2. Remove the valve cover – remove the 4 Phillips screws.
3. Locate the Circuit Board directly behind the valve cover.
4. Disconnect all wires. We recommend that you write down the location of each wire before disconnecting.
5. Remove the four (4) small Phillips screws that secure the Circuit Board to the Electrical Panel.
5. Replace the Circuit Board.
6. Reconnect all wires to their proper locations on the Circuit Board.
7. Check the Temperature Adjust Pot on the Circuit Board, to ensure it is in the 12 o'clock position.
8. Replace the valve cover.
9. Plug in the dispenser.
10. Turn the power switch back ON.
11. Check operation to ensure dispense buttons are working and the dispenser temperature is cooling properly.



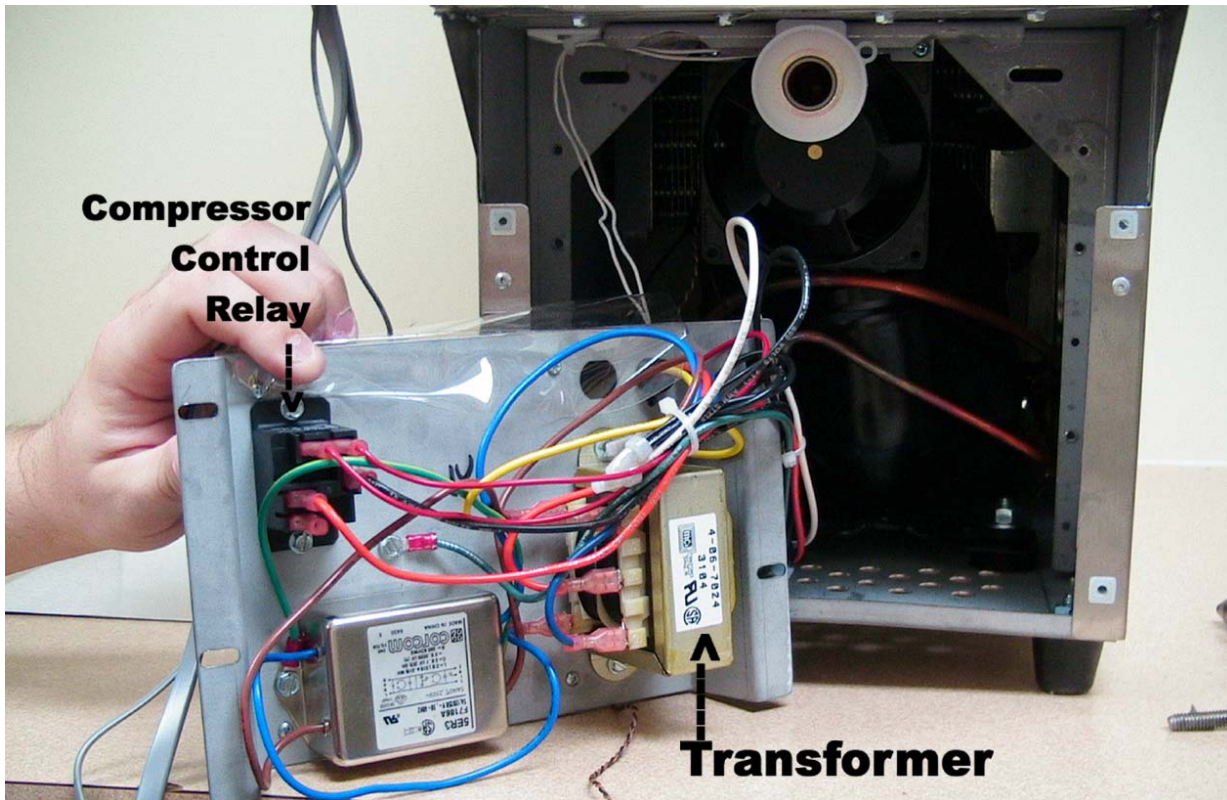

Remove & Replace Compressor Relay

1. Turn the power switch OFF and unplug dispenser.
2. Remove the valve cover – remove the 4 Phillips screws.
3. Locate the Electrical Panel holding the Circuit Board.
4. Unscrew and lower the Electrical Panel steel plate and gently turn it around – 4 hex/slot screws.
5. Locate the Compressor Relay on the back of the Electrical Panel, held in place by 2 hex/slot screws.
6. Remove the 2 screws and the wires attached. We recommend that you identify the wires for replacement before you remove them.
7. Replace the Compressor Relay.
8. Reconnect the wires and reinstall Electrical Panel steel plate.
9. Replace the valve cover.
10. Plug in the dispenser.
11. Turn the power switch back ON.

Remove & Replace Transformer

1. Turn the power switch OFF and unplug dispenser.
2. Remove the valve cover – remove the 4 Phillips screws.
3. Locate the Electrical Panel holding the Circuit Board.
4. Unscrew and lower the Electrical Panel steel plate and gently turn it around – 4 hex/slot screws.
5. Locate the Transformer on the back of the Electrical Panel, held in place by 2 hex/slot screws.
6. Remove the 2 screws and the wires attached. We recommend that you identify the wires and their locations before you remove them.
7. Remove the Transformer.
8. Replace the Transformer.
9. Reconnect the wires and reinstall Electrical Panel steel plate.
10. Replace the valve cover.
11. Plug in the dispenser.
12. Turn the power switch back ON.

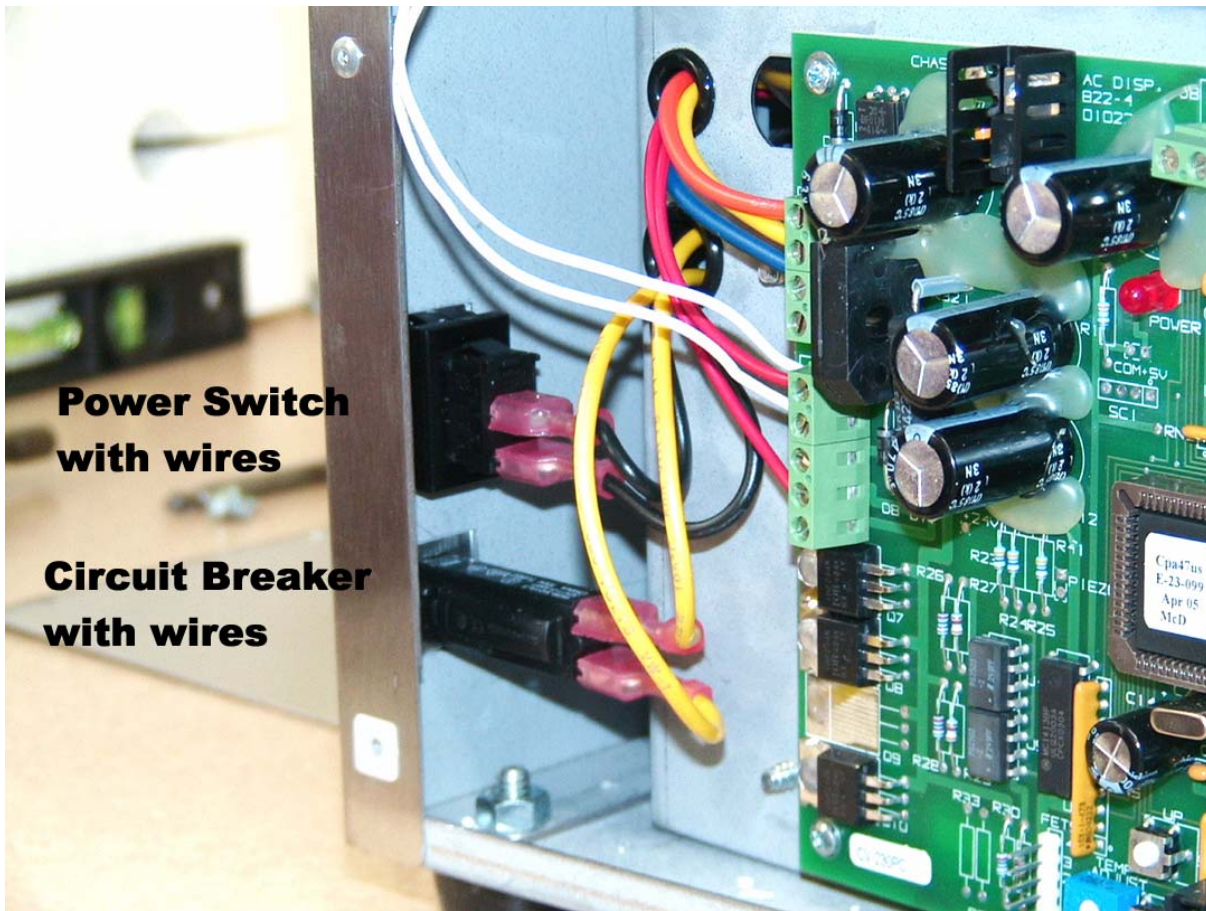

**Power Switch
with wires**

**Circuit Breaker
with wires**

Remove & Replace Circuit Breaker

1. Turn the power switch OFF and unplug dispenser.
2. Remove the valve cover – remove the 4 Phillips screws.
3. Locate the 3 Amp Circuit Breaker on the lower left side of the dispenser, toward the front.
4. Remove the 2 wires attached to the Circuit Breaker.
5. Pinch together the two tabs that retain the Circuit Breaker and push it out.
6. Replace with a new Circuit Breaker, using the reverse steps.
7. Replace the valve cover.
8. Plug in the dispenser.
9. Turn the power switch back ON.

Remove & Replace ON/OFF Switch

1. Turn the power switch OFF and unplug dispenser.
2. Remove the valve cover – remove the 4 Phillips screws.
3. Locate the ON/OFF switch on the lower left side of the dispenser, toward the front.
4. Remove the 2 wires attached to the On/OFF Switch.
5. Pinch together the two tabs that retain the ON/OFF Switch and push it out.
6. Replace with a new ON/OFF Switch, using the reverse steps.
7. Replace the valve cover.
8. Reconnect the AC power supply by plugging the dispenser in to the wall outlet.
9. Turn the power switch back ON.

Remove and Replace Solenoid

1. Remove valve cover.
2. Remove valve assembly, including the plunger and spring.
3. Disconnect the 2 white wires at the left side of the Circuit Board, at positions +24 and SOL1.
4. Remove the 4 Phillips screws holding the Solenoid bracket in place.
5. Remove the Solenoid.
6. Replace the Solenoid, following the reverse order of steps.

NOTE: During installation, do not tighten the screws holding the solenoid bracket until the valve is in place. Make sure the plunger is aligned properly in the valve and the plunger is not binding before tightening the bracket screws.



Step 2



Step 3



Step 4

Remove & Replace Condenser Fan

1. Turn the power switch OFF and unplug dispenser.
2. Remove the valve cover – remove the 4 Phillips screws.
3. Locate the Electrical Panel holding the Circuit Board.
4. Unscrew and lower the Electrical Panel steel plate – 4 hex/slot screws.
5. Locate the Condenser Fan attached to the bottom of the floor of the refrigerated compartment. It is held in place by 2 bolts and nuts.
6. Locate and cut the two wires attached to the fan and remove it.
7. Splice the wires from the new fan to the existing wires that were cut in Step 5. Use UL-approved marrettes to splice the wires together.
8. Reinstall the fan and the Electrical Panel steel plate.
9. Replace the valve cover.
10. Reconnect the AC power supply by plugging the dispenser in to the wall outlet
11. Turn the power switch back ON.

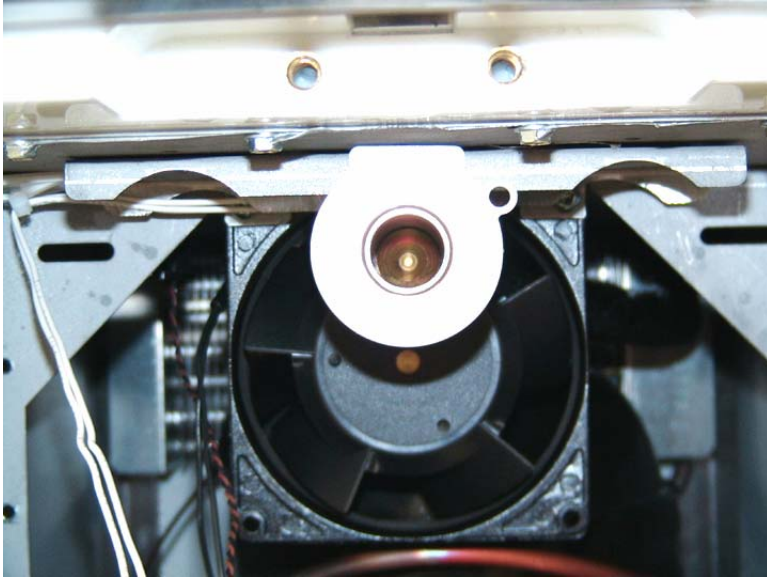

Remove Back Panel

1. Turn the dispenser around to access the back panel.
2. Remove the 10 screws holding the back panel.

Replace Electrical Cord

1. Turn the power switch OFF and unplug dispenser.
2. Remove the back panel by removing the 9 screws.
3. Using pliers, depress the plastic wire strain relief grommet where the cord enters the stainless steel body of the dispenser and turn it to the right.
4. Slide the cord out.
5. Remove the ground wire from the cord and from the grounding post.
6. Cut and splice the live and neutral wires from the AC power cord.
7. Reconnect with appropriate UL-approved marrettes. Do **not** use electrical tape.
8. Replace the strain relief.
9. Replace the back panel.
10. Reconnect the AC power supply by plugging the dispenser in to the wall outlet
11. Turn the power switch back ON.

6. CHECKS AND ADJUSTMENTS

AC Outlet for 120 VAC

1. Using a Digital Multi-Meter set to AC (~), place probes in the slotted sections of the wall outlet. The Digital Multi-Meter should read 110-120 VAC \pm 3 Volts. If this voltage is 0 Volts AC, this may indicate a tripped Circuit Breaker in the building's Electrical panel. If the voltage is outside the specified range, please contact a licensed electrician to investigate.

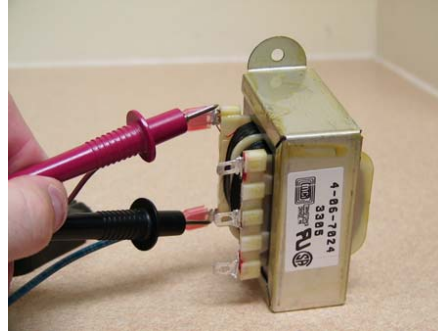

AC 120 VAC input to Transformer

Note: Turn the power off until you are ready to check.

1. Locate the Transformer on the back of the Electrical Panel. You will see 2 wires entering the Transformer. For location of Transformer, see page 21.
2. Carefully pull back the push-on connectors.
3. With Digital Multi-Meter set to AC (~), place probes on the posts of the Transformer. Your meter should read 110-120 VAC \pm 3 Volts.
4. Replace as necessary.

AC 24/12 VAC output to PCB from Transformer

Note: Turn the power off until you are ready to check.
ct = center tap

1. Locate the Transformer on the back of the Electrical Panel. You will see 3 wires from the Transformer.
2. Carefully pull back the push-on connectors.
3. With Digital Multi-Meter set to AC Volts (~), place the probes on the posts of the Transformer. Your meter should read:
 - Orange (ct) ~ Yellow = 12 VAC \pm 1 VAC
 - Orange (ct) ~ Blue = 12 VAC \pm 1 VAC
 - Yellow ~ Blue = 24 VAC \pm 1 VAC
4. If you do not get these voltages, check the input to the transformer and the Circuit Breaker for trip and/or continuity. NOTE: The power LED on the Circuit Board may still illuminate, even with the Circuit Breaker tripped.

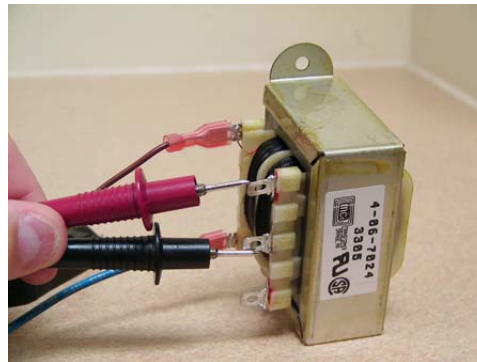

DC 2.8 → 3.8 VDC input of Valve Thermistor

Note: Turn the power off until you are ready to check.

1. Remove the valve cover – remove the 4 Phillips screws.
2. Locate the Valve Thermistor.
3. Check for +2.8 VDC → +3.8 VDC between Pin 1 (IN) and Pin 2 (Gnd) on (J8) of the 'TEMP.' terminal strip located at the top of the Circuit Board (corresponds to room temperature 75 °F to → 14 °F respectively).
4. If these voltages are not measured, replace the Thermistor. See page 11.
5. You can also check the resistance of this Thermistor – see below.



Resistance of Valve Thermistor

Note: Turn the power off until you are ready to check.

1. Disconnect both wires.
2. Check for approximately 10K – 50K ohms at the two wire leads of the thermistor.
3. If you do not get a similar reading, replace the valve thermistor.
To replace valve thermistor:
 - 5a. Disconnect Thermistor.
Dispenser goes into a default "ON" time of 6 minutes and an "OFF" time determined by the temperature adjust potentiometer located on the Circuit Board (R36).
 - 5b. Replace Thermistor immediately.

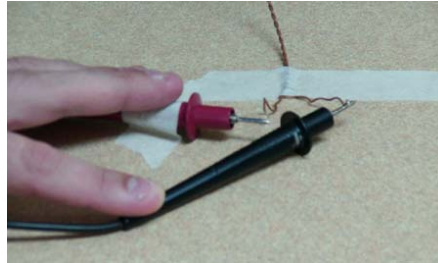

DC 2.8 → 3.8 VDC input of Display Thermistor

Note: Turn the power off until you are ready to check.

1. Remove the valve cover – remove the 4 Phillips screws.
2. Locate the Display Thermistor connector AD1 (2-pin connector) on the bottom right side of the Circuit Board.
3. With the Digital Multi-Meter set to DC Volts (---), check for +2.8 VDC → +3.8 VDC (corresponds to room temperature 75 °F to → 14 °F respectively).
4. If these voltages do not fit into this range, replace the Thermistor.
5. You can also check the resistance of this Display Thermistor – see below. disconnect the wires and check for approximately 10K – 50K ohms at the two wire leads of the thermistor. If you do not get a similar reading, replace the Display Thermistor.

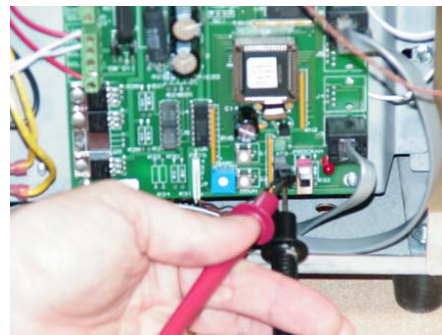

Resistance of Display Thermistor

Note: Turn the power off until you are ready to check.

1. Disconnect the wires.
2. Check for approximately 10K – 50K ohms at the two wire leads of the thermistor. If you do not get a similar reading, replace the Display Thermistor.
To replace Display Thermistor:
 - a. Disconnect Display Thermistor.
Dispenser goes into a default "ON" time of 6 minutes and an "OFF" time determined by the temperature adjust potentiometer located on the Circuit Board (R36).
 - b. Replace Display Thermistor immediately.



38 VDC output to Solenoid

Note: Turn the power off until you are ready to check.

1. Remove the valve cover – remove the 4 Phillips screws.
2. With the Digital Multi-Meter set to DC Volts, check for +24 → +38 VDC (\pm) between pin 1 (+24) and Pin 2 (SOL 1) on J2 terminal strip.
3. Press the Large size button.
4. If you are not getting the proper voltage at these test points, replace the Circuit Board.
If you are using a digital meter, the measurement may flash only momentarily on the display of the meter.



38 VDC output to Compressor Relay

1. Turn Power switch OFF.
2. Remove the valve cover.
3. Turn R36 Temp Adjust potentiometer to 5:00 o'clock on the Circuit Board.
4. Turn Power switch back ON.
5. Wait 2½ minutes. The compressor should start.
If not, with the Digital Multi-Meter set to DC Volts, check for approximately +38 VDC between Pin 1 (+24) and Pin 5 (REL) on the (J2) terminal strip (red wires).
6. If voltage is okay at these points, then the Circuit Board is okay.
If voltage is not apparent, change the Circuit Board.
See page 14, 15 for proper setup of temperature.
Do **not** leave the Temp Adj at 5 o'clock – that will freeze dairy product. See page 15.
7. Replace the valve cover.
8. Turn the Power Switch back ON.



120 VAC input to Compressor Back

Note: Turn the power off until you are ready to check.

1. Remove the back panel – remove the 9 Phillips screws holding it in place.
2. Remove the retaining clip holding the black plastic cover to the rear of the Compressor.
3. Remove the cover.
4. Gently pull back the connector to the Compressor without completely removing it.
5. With the Digital Multi-Meter set to AC Volts (\sim), check for 110-120 VAC \pm 3 Volts on the bottom two leads.
If you don't get this reading, check the wall outlet.
6. Replace the compressor cover.
7. Replace the back panel.

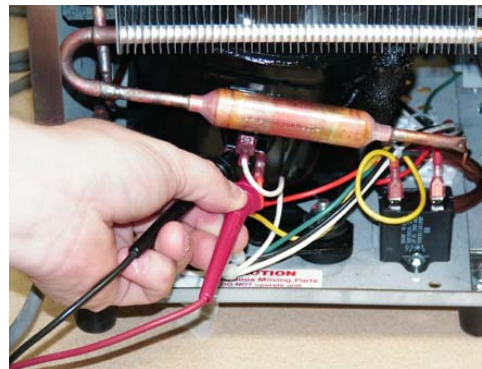

Proximity Switch Continuity Check

This switch activates the Reset function after full bags or tanks are loaded into the dispenser. The switch is located in the valve. The Check is done on the Circuit Board.

Note: Turn the power off until you are ready to check.

1. Check continuity of magnetic reed switch.

Test points are at terminal blocks at the top of the Circuit Board:
(At the J7 – Case Switch section of the Board, test Pin 1 = GND and Pin 2 = 1). See page 32.

With the valve door open, switch will read open.

With the valve door closed, the switch will read 'short' or 'closed circuit' (zero ± ohms).

2. If continuity reading indicates a short or closed circuit, whether or not the valve door is open, replace Proximity Switch.

Portion Programming is not being reset when a new bag or tank is loaded.

To replace Proximity Switch:

1. Remove valve cover – remove the 4 Phillips screws.
2. Remove the 3 valve screws
3. Disconnect wiring
4. Push out the switch
5. Install new switch. Ensure you route it through hole in spring retainer.
6. Connect wires.
7. Replace the 3 valve screws
8. Replace the valve cover – replace the 4 Phillips screws.



Quantity/Volume Checks: To Adjust Dispense Amounts

To Verify Dispense Amounts

1. Before attempting adjustment of the volume amounts, perform the following:
 - proximity switch continuity check
 - valve removed and cleaned
 - Insert a full bag of product, test and record all volumes
 - Ensure the product tube is not pinched
 - Ensure proper product temperature – do Product Temperature Check below

Product Temperature Check

1. It is imperative that your dispenser's temperature is stabilized for at least 24 hours before attempting an adjustment.
2. Place product or water at 38 °F in a container. Place the container in the refrigerated compartment for 24 hours.
3. Check the temperature of the fluid. Do not rely on the LCD displayed temperature found on the front door.
4. If the fluid is not under 40 degrees, perform the Product Temperature Adjustment on the Circuit Board. See Page 15.

To Adjust Dispense Amounts – Circuit Board

1. Enter Program Mode by sliding the program mode switch (S3) on the Circuit Board to the "down" position. (Page 15)
 2. Table selection can be accomplished for alternate products by pressing either the "UP" or "DOWN" buttons on the PCB for any of the following tables:
 - a. Table 0 Customer Specific Products (contact A. C. Dispensing Equipment Inc)
 - b. Table 1 Customer Specific Products (contact A. C. Dispensing Equipment Inc)
 - c. Table 2 Customer Specific Products (contact A. C. Dispensing Equipment Inc)
 - d. Table 3 Customer Specific Products (contact A. C. Dispensing Equipment Inc)
 3. If "Size" adjustments are required, they are accomplished by making a size selection on the Button Panel and adjusting using Circuit Board push buttons accordingly. Each press of either "UP" or "DOWN" push button is equal to 1% adjustment to the dispense volume.
 4. If dispenser is a DV model, the Modifier Button must be selected to facilitate Steps 2 and 3 for the DV function. When the S3 switch is down, the red LED on the Modifier Button will flash to indicate you are in Program Mode. While in Program Mode, pressing the Modifier Button toggles the LED between flashing and solid. If the Led is on solid, you are adjusting Modifier dispense amounts; if the red Led is strobing, you are adjusting coffee dispense amounts.
- NOTE: If dispenser is a DV model, the default product selection table needs to be identical to the DV table selection, ie. Coffee on Table 2 (18% Cream 2.5 US Gal) then DV needs to be Table 2 (18% Cream 2.5 US Gal).

Displayed Temperature Offset Check

1. It is imperative that your dispenser's temperature is stabilized for at least 24 hours before attempting an adjustment.
2. Place product or water at 38 °F in a container and place it in the refrigerated compartment for 24 hours.
3. Check the temperature of the fluid.
4. Compare it to the LCD-displayed temperature on the front door.
5. If the fluid is not correct at ± 2 degrees, perform the following:

Displayed Temperature Adjustment

1. Locate the Program Switch "S3" on the lower right corner of the Circuit Board.
2. Locate the 2 white or black buttons (S1 & S2) to the left of the Program Switch on the Circuit Board. "UP" and "DOWN" are written above and below these switches.
3. Depress and hold both switches at the same time as you slide the 'Program Switch' to the down position and continue to hold these buttons down until the display in the LCD on the door reads "MEMORY CONTENTS". Red LED will also turn on.
4. Release both "UP" and "DOWN" buttons.
5. Press the "DOWN" button until "TO or TEMP OFFSET" is displayed in the LCD.
6. Use the Small and Medium button location on the button panel to adjust the value that has been retrieved. "07" is the factory setting. Each increment/decrement will affect the displayed temperature by "2 °F" respective to the incremented or decremented value. The Small button lowers the displayed temperature by 2 °F. The Medium button increases the displayed temperature by 2 °F.
7. When you have adjusted the temperature setting the correct number of degrees, press the "L" button. If your dispenser has an XL button, it may be used for this procedure.
8. Turn off the 'Program Switch' (S3). This step completes the calibration of the Displayed Temperature.
9. Turn the Power OFF. Turn the Power back ON.
10. Verify that the display temperature matches the product temperature.

Displayed Temperature Adjustment for a one-button dispenser:

- Follow Steps 1 to 5 above.
- Press the button on the door. It will increase temperature in 2° F increments for each button press to the maximum temperature and then cycle back to the minimum temperature and continue increasing in 2° F increments. Continue pressing until you reach the desired temperature.
- Turn off the 'Program Switch' (S3). This step completes the calibration of the Displayed Temperature.
- Turn the Power OFF. Turn the Power back ON.
- Verify that the display temperature matches the product temperature.

Gas Pressure Check

1. Remove the back panel – remove the 9 Phillips screws holding it in place.
2. Turn the power switch OFF.
3. Locate the Schrader® valve (access valve) below the Condenser.
4. Remove the brass cap from the Schrader® valve.
5. Attach the 'low side' pressure gauge setup for 134A Refrigerant (preferably without hose, as shown in the picture) to the Schrader® valve.
6. Turn the power switch back ON. Wait for the compressor to start.
7. After the compressor starts, watch the gauge – note the suction pressure. The gauge should read 0 psi \pm 3 psi of vacuum. If it does not, add or remove refrigerant until the proper pressure is obtained. Do not remove the gauge until the compressor is turned off and the suction pressure is above 5 PSI.
8. Wait until the dispenser stabilizes before leaving the site.
9. Replace the back panel.



7. DIAGRAMS

WIRING DIAGRAM:

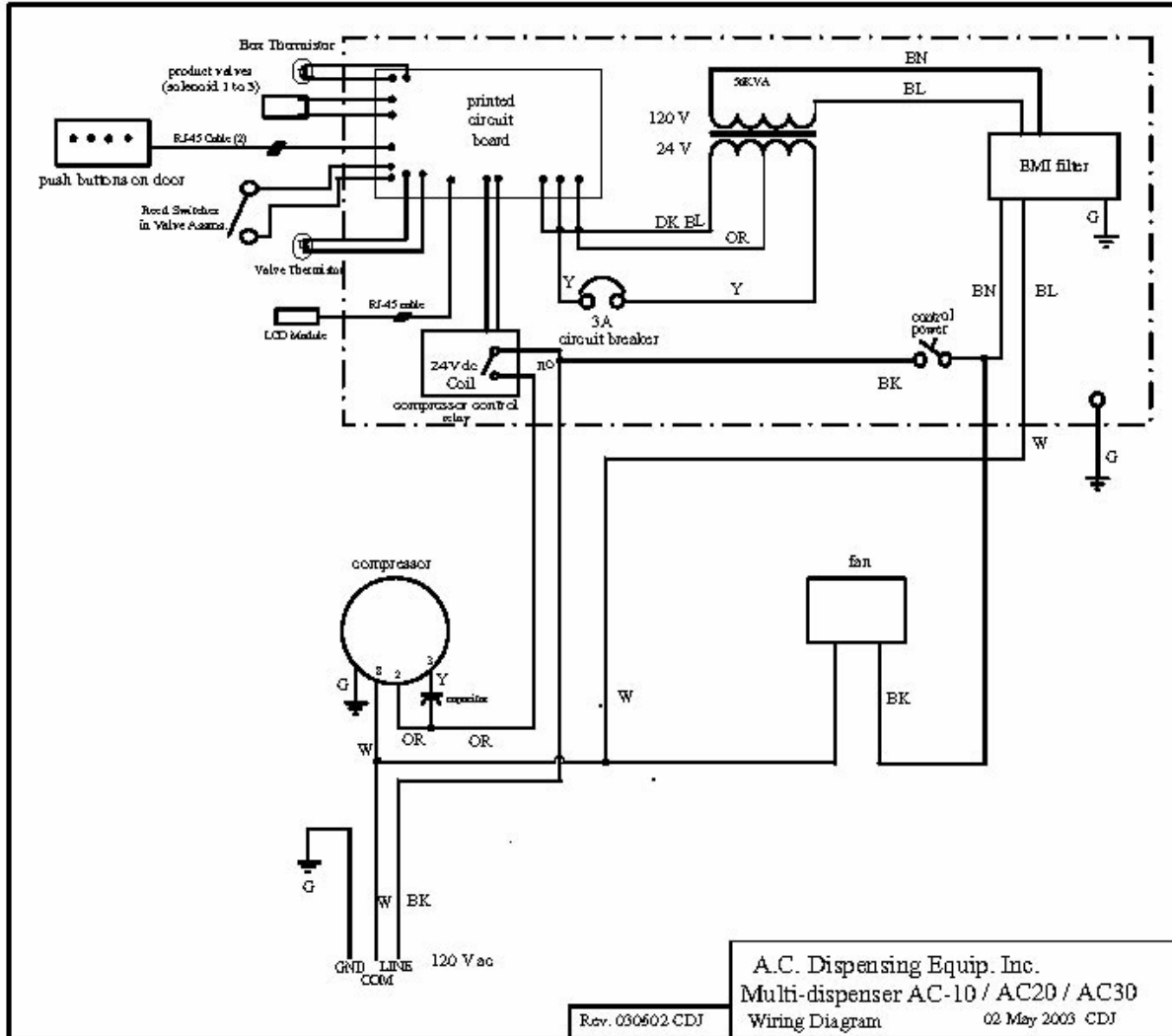

ELECTRICAL SYSTEM:

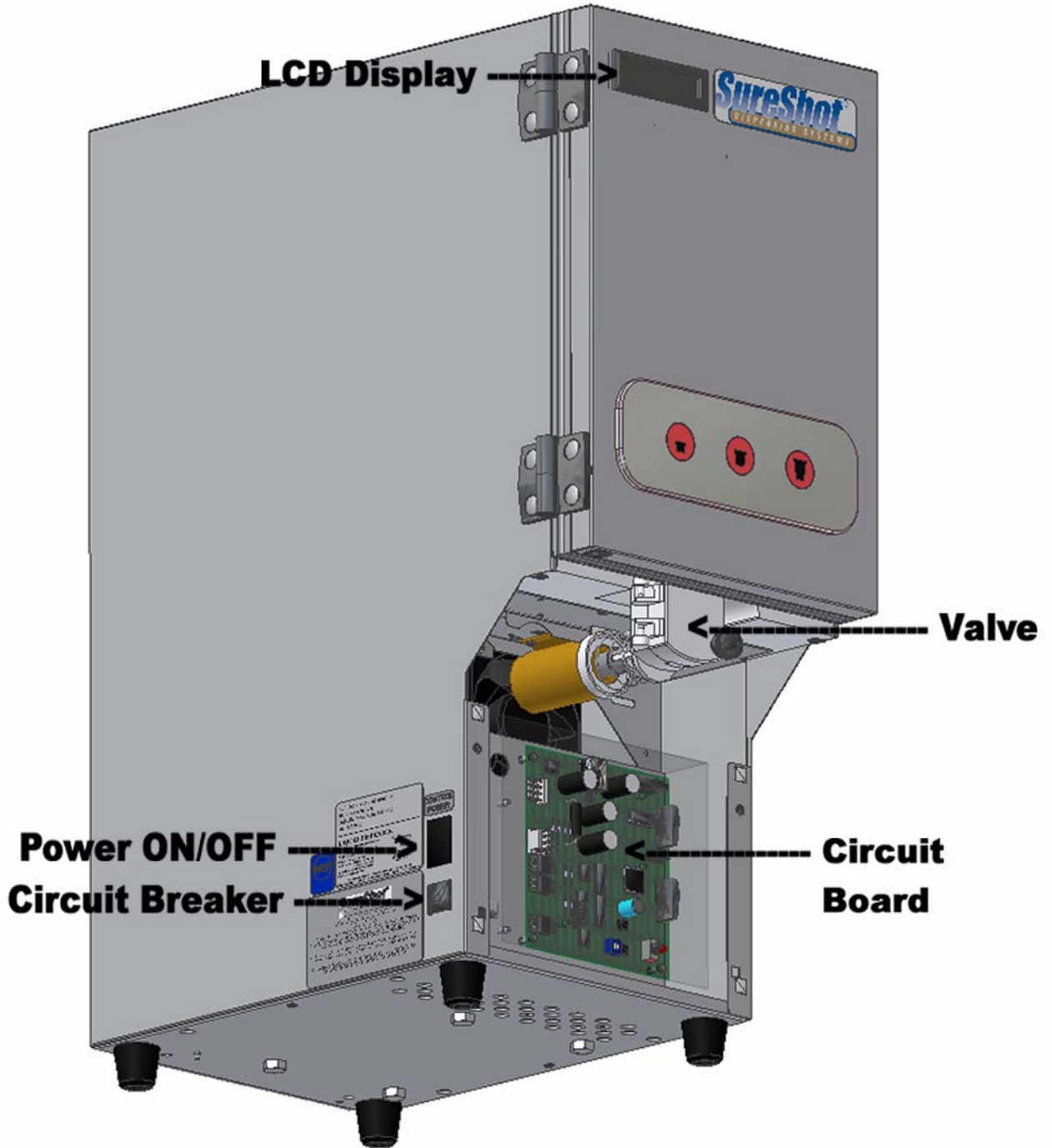

Electrical System

8. PARTS LIST

NOTE: The Item Number in the table below refers to the number on the General Assembly drawing on page 33.

ITEM	QTY	PART #	DESCRIPTION
1	1	E-21-002	FAN
2	1	A-99-005	COMPRESSOR ASSY
3	1	E-13-019	POWER CORD – (WIRE HARNESS)
4	1	E-14-001	3 AMP CIRCUIT BREAKER
5	1	E-08-011	ON-OFF SWITCH – RECESSED
6	1	E-02-001	RUN CAPACITOR
7	1	R-02-001	CONDENSER
8	1	A-07-003	VALVE DOOR – complete without thermistor
9	1	A-04-034	FRONT PANEL ASSY (110) - lower front panel/valve cover
10	1	A-09-026	DOOR ASSY – FRONT - 3 button
		A-09-021	DOOR ASSY – FRONT – 4 button
		A-09-017	DOOR ASSY – FRONT – 5 button
11	1	A-04-033	CATCH TRAY ASSY – (110 COUNTER)
12	1	A-12-016	CIRCUIT BOARD ASSY
13	1	E-10-001	COMPRESSOR CONTROL RELAY
14	6	F-04-003	8-18 X 5/16 S-HWH TS (TYPE B)
15	1	E-22-001	POWER TRANSFORMER (7024)
16	1	E-99-003	CIRCUIT BOARD SHIELD – PLASTIC (6.875)
17	1	A-13-007	PRODUCT SOLENOID ASSY (.750-2X45-MOLDED)
18	1	P-01-004	SOLENOID SPRING RETAINER
19	1	P-99-001	PRODUCT SOLENOID SPRING #10
20	2	F-05-007	1/4-20 UNC-2A X 1 SS SHCS
21	4	F-14-009	LEG – 1” PLASTIC
22	13	F-04-002	8-18 X 3/8 SS P-TH TS
23	1	M-01-074	BACK PANEL (10L)
	1	E-05-015	MICROPROCESSOR CHIP NOTE: When ordering, specify customer and amounts
	1	E-16-001	LCD DISPLAY
	1	A-99-001	VALVE THERMISTOR
	1	A-99-003	DISPLAY THERMISTOR

9. TROUBLESHOOTING (AC10-PC Refrigerated Liquid Dispensers)

PROBLEM	ACTION
Dispenser is not level	<ol style="list-style-type: none"> 1. Check to make sure all four legs at the bottom corners of the dispenser are in place. 2. Tighten any legs that are loose. 3. Make sure the legs are not bent. 4. Replace any bent or missing legs. Replacement legs may be obtained by contacting SureShot Dispensing Systems® Technical Assistance Center at 1-888-777-9990 or 1-902-865-9602. 5. Make sure the dispenser is sitting level on the counter. For dispensers with adjustable legs, adjust legs to level dispenser. Use a bubble level to ensure accuracy.
No power at the plug	<ol style="list-style-type: none"> 1. Have a qualified person check the fuse box or circuit breaker to restore power to the circuit. 2. Check AC outlet to make sure it is 120 VAC. 3. Try another working appliance in the outlet to confirm that the problem is in the outlet.
Dispenser will not turn on	<ol style="list-style-type: none"> 1. Make sure the power cord is plugged in to an active power source. 2. Check the ON/OFF switch (See page ____) on the left side of the dispenser to make sure it is ON. 3. Check to make sure the circuit breaker on the left side of the dispenser has not tripped out. If it has, turn the power switch OFF, reset the circuit breaker by gently pushing it in once to reset it – push in at the top of the breaker until no white is showing. Then, turn the power back ON.
Dispenser will not dispense product	<ol style="list-style-type: none"> 1. Make sure the power cord is plugged in to an active power source. 2. Make sure there is product – cream, etc – in the product compartment. 3. Make sure the product dispensing tube from the product case is clear of blockage and is properly aligned in the valve with no twists or kinks and is not pinched off. 4. Make sure the valve door is closed. 5. Check the valve area and the valves to make sure they are clean. NOTE: most problems are caused by sticky valves. To clean, see pages 11, 12. 6. Turn off the dispenser, wait 10 seconds, then turn the dispenser back on to reset the microcontroller. 7. Check the temperature inside the refrigerated product compartment, to make sure it is within the temperature range of 35 °F to 40 °F (1.6 °C to 4.4 °C). If the dispenser is running cold, it could form ice which may interfere with the flow of product. If a temperature adjustment is required, see page 14, 15. If further assistance is required, contact the A. C. Dispensing Equipment Inc. Technical Assistance Center at 1-888-777-9990 or 1-902-865-9602. 8. Ensure that the red power indicator light on the button panel is on. If the power indicator light is not on, check the circuit breaker (See page 2). To check the Circuit Breaker: - Confirm that the Circuit Breaker on the lower left front side of the dispenser has not tripped out. If it has, turn OFF the dispenser, re-set the circuit breaker by gently pushing it in once to reset it – push in at the top of the breaker until no white is showing. Then, turn the power back ON. 9. Ensure that the program switch located on the lower left side of the circuit board is in the “up” position and that the red LED located next to it is OFF. 10. If there is still no product dispensed, call the SureShot Dispensing Systems® Technical Assistance Center at 1-888-777-9990 or 1-902-865-9602.

<p>The dispenser is not dispensing the proper amount of product</p>	<ol style="list-style-type: none"> 1. Wrong dairy product is being dispensed – for example, skim instead of cream. 2. Check to ensure that the system is reset properly. See page 16. 3. Make sure that the product delivery tube is inserted in the valve correctly since incorrect placement can affect product delivery. See page 7. 4. Check to ensure that valve and valve area are clean. 5. Make sure the valve door is not being opened before the product bag or tank is empty. 6. Make sure product tanks are filled to the required level. 7. Check to see if the refrigeration unit is too cold or too warm. Ice may interfere with product flow. Check the product temperature to ensure it is approximately 38 °F or 3.3 °C. Note: temperature affects the flow of cream and some other liquids. Ice may interfere with product flow. Warm product flows faster. 8. Check the refrigeration temperature. Ice may interfere with product flow. To adjust temperature, see page 14, 15. 9. Check to ensure the system is re-setting properly. The volumes to be dispensed are pre-set electronically in our factory and are pre-set to the specified amounts automatically each time the front valve door is opened. Follow this procedure to check to ensure the dispenser is re-setting: <ol style="list-style-type: none"> a. make sure no product is spilled during the test by pinching off the product delivery tube with a pinch clip or fork before you begin. b. open the valve door by unscrewing the knob in a counter-clockwise motion. c. TR1 will be displayed in the LCD when the valve door is opened. A new bag of product must be loaded to ensure proper volumes of product are delivered. <ol style="list-style-type: none"> ii. If the display does not show TR1 when the valve door is opened, the reed switch is defective and must be replaced. Call the SureShot Dispensing Systems® Technical Assistance Center at 1-888-777-9990 or 1-902-865-9602 for assistance. d. ensure the product delivery tube is inserted properly in the valve door. e. close the valve door securely, by replacing the knob-screw. Do not over-tighten the screw. f. push a dispense button on the front door. If correct amount of product is dispensed, the machine has re-set and is working properly. If correct amount of product is not dispensed, call the SureShot Dispensing Systems® Technical Assistance Center at 1-888-777-9990 or 1-902-865-9602 for assistance. NOTE: Test the operation of all dispense buttons and test the amounts dispensed by each.
<p>Valve is sticky</p>	<ol style="list-style-type: none"> 1. A sticky valve is usually caused by product build-up on the valve. The problem is corrected by cleaning the valve. See Instructions on pages 11, 12. 2. If this doesn't correct the problem, call the SureShot Dispensing Systems® Technical Assistance Center at 1-888-777-9990 or 1-902-865-9602.
<p>Valve door is broken</p>	<p>This indicates the door hinge is broken. The hinge is in two parts: hooks, pins.</p> <ol style="list-style-type: none"> 1. Hooks: If either or both of the plastic “hooked” areas of the hinge are missing, the door section valve assembly is broken and must be replaced. Contact SureShot Dispensing Systems® Technical Assistance Center at 1-888-777-9990 or 1-902-865-9602 for replacements. 2. Pins: If either or both plastic “pins” are missing from the hinge area, the body section of the valve is broken and must be replaced. Contact SureShot Dispensing Systems® Technical Assistance Center at 1-888-777- 9990 or 1-902-865-9602 for replacements.

<p>Dispenser is unusually warm on the exterior</p>	<ol style="list-style-type: none"> 1. Make sure any vents at the top and back of the dispenser are not blocked. 2. Make sure the dispenser is not too close to a heat-generating machine, such as a coffeemaker. Allow a minimum 1-inch airspace between machines at all times. 3. Make sure the dispenser is level on the countertop. 4. Make sure the condenser is not dirty: Remove the back panel to examine the condenser. If it is dusty or dirty, use a vacuum to clean it. 5. Make sure the fan is operating. Remove the front panel and observe the fan inside the dispenser, in front of the compressor and behind the circuit board. (See page 14) Do a visual inspection only. Be careful not to injure fingers by sticking them in the fan. If the fan is not running, call SureShot Dispensing Systems® Technical Assistance Center at 1-888-777-9990 or 1-902-865-9602.
<p>Dispenser is unusually warm on the interior</p>	<ol style="list-style-type: none"> 1. Check the product temperature, to ensure that the product is properly cooled to approximately 38 °F or 3.3 °C before it is loaded into the dispenser. 2. Check to ensure the vents at the top back of the dispenser are not blocked. 3. Check to make sure the dispenser is not too close to a heat-generating machine, such as a coffeemaker. Allow a minimum 1-inch airspace between machines. 4. Check to ensure that the dispenser is level on the countertop at all times. 5. Check to ensure the condenser is not dirty. Remove the back panel to examine the condenser. If it is dusty or dirty, use a vacuum to clean it. 6. The dispenser may be on defrost cycle. The defrost cycle time is 22 minutes in duration. If, after 22 minutes have passed, the dispenser is not cool, re-set the defrost cycle by turning OFF the dispenser, waiting 10 seconds, and turning it back ON again. It should become cold after approximately 12 minutes. 7. Check to ensure the fan is operating. Remove the front panel and observe the fan inside the dispenser, in front of the compressor and behind the circuit board. (See page14) Do a visual inspection only. Be careful not to injure fingers by sticking them in the fan. If the fan is not running, call the SureShot Dispensing Systems® Technical Assistance Center at 1-888-777-9990 or 1-902-865-9602. 8. If the problem is still not solved, call the SureShot Dispensing Systems® Technical Assistance Center at 1-888-777-9990 or 1-902-865-9602.
<p>Dispenser is too cold (if dairy product is at least 34° or less for longer than an hour)</p>	<ol style="list-style-type: none"> 1. Check product temperature. If temperature adjustment is required, follow instructions on pages 14, 15. 2. Call the SureShot Dispensing Systems® Technical Assistance Center at 1-888-777-9990 or 902-865-9602.
<p>Frost build up in the refrigeration compartment</p>	<ol style="list-style-type: none"> 1. Check the temperature inside the refrigerated product compartment, to make sure it is within the temperature range of 35 °F to 40 °F (1.6 °C to 4.4 °C). If the dispenser is running cold, it could form ice. 2. If the dispenser has accumulated ice or frost at the top of the compartment, it is best to remove it during a defrost cycle, which runs automatically and will be indicated on the LCD display panel. Forming ice does not necessarily mean the temperature of the product is too cold. If excessive ice or frost builds up, it should be removed by hand during that defrost cycle. 3. Ice may be removed during a product change: turn off the dispenser. Leave the door open for about 15 minutes to allow the ice to soften. Remove the ice by hand. 4. If a temperature adjustment is required, follow the instructions on pages 14, 15. If further assistance is required, contact the SureShot Dispensing Systems® Technical Assistance Center at 1-888-777-9990 or 1-902-865-9602.

Dispenser is leaking product	<ol style="list-style-type: none"> 1. Make sure the valve door is closed securely and its knob-screw is tightened properly. 2. Make sure the product dispensing tube is properly aligned in the centre of the delivery valve. 3. Check the tube for cracks or disfiguration. If the tube is cracked or disfigured, replace it. See page 7. 4. Check the valve to make sure that it is not dirty. If required, clean the valve following instructions on pages 11, 12. 5. Check to ensure that the plunger and valve assembly are correct. Ensure that the spring is properly seated in the spring retainer.
LCD Display on the front door does not come on	<p>Check the circuit breaker. If it has tripped out, it must be reset. To Reset the circuit breaker:</p> <ol style="list-style-type: none"> 1. Turn the power switch OFF. 2. Check the circuit breaker: <ul style="list-style-type: none"> - Locate the Circuit Breaker on the lower left side of the dispenser. - Gently push the Circuit Breaker in once to reset it – push in at the top of the breaker until no white is showing. Then, turn the power back ON. 3. Turn the power switch ON. 4. If the LCD Display does not come on now, call the SureShot Dispensing Systems® Technical Assistance Center at 1-888-777-9990 or 1-902-865-9602.

If these instructions do not correct your problem or if you have other problems, contact:

SureShot Dispensing Systems® Technical Assistance Center

A. C. Dispensing Equipment Inc

1-888-777-9990 or 1-902-865-9602

NOTE: The Product Identification Label on the left side of each dispenser includes the contact telephone number for the SureShot Dispensing Systems® Technical Assistance Center at A. C. Dispensing Equipment Inc. Refer to the Serial Number and the Model Number on the label when calling A. C. Dispensing Equipment Inc. These numbers are crucial to helping us provide prompt and effective service. **This will save you time.**

NORTH AMERICAN WARRANTY

All dispensing equipment manufactured by A.C. Dispensing Equipment Inc. is warranted against defects in materials and workmanship for a period of one (1) year from the date of purchase.

A. C. Dispensing Equipment Inc.'s obligation under this warranty is limited to the repair of defects as outlined by an A. C. Dispensing Equipment Inc. factory-authorized service agency or one of its sub-service agencies.

This Warranty does not apply to installation or problems because of installation. This Warranty does not apply to normal preventative maintenance, maintenance or adjustment.

THIS WARRANTY WILL BE NULL AND VOID IF THE WARRANTY REGISTRATION CARD IS NOT RETURNED TO A. C. DISPENSING EQUIPMENT INC. WITHIN 60 DAYS OF PURCHASE.

This warranty is subject to the following conditions:

- This warranty applies to the original owner only and is not assignable.
- Only pre-authorized service agencies directed by A.C. Dispensing Equipment Inc. are to be utilized.
- Should any product fail to function in its intended manner under normal use within the limits defined in this warranty, at the option of A. C. Dispensing Equipment Inc. such product will be repaired or replaced by A.C. Dispensing Equipment Inc. or its Authorized Service Agency. A. C. Dispensing Equipment Inc. will be responsible only for charges incurred or service performed by its Authorized Service Agencies. The use of other than A. C. Dispensing Equipment Inc. Authorized Service Agencies will void this warranty and A. C. Dispensing Equipment Inc. will not be responsible for such work or any charges associated with such work. The closest A. C. Dispensing Equipment Inc. Authorized Service Agency must be used and must be dispatched by A. C. Dispensing Equipment Inc.

TIME PERIOD:

One year on parts and labour, effective from the date of purchase. The Authorized Service Agency may, at its option, require proof of purchase. Parts replaced under this Warranty are warranted for the unexpired portion of the original product warranty only.

24-hour Toll-Free Service is available at **1-888-777-9990 or 1-902-865-9602**

A service consultant is available to assist you during our normal business hours. All service-related issues will be addressed by a return telephone call the next business day.

WARRANTY PROCEDURE:

1. Secure the model and serial number from the data tag on the lower left side of the dispenser.
2. Call the number provided on the service label on the dispenser.
3. Our technical support staff will discuss the issue with you and, if necessary, dispatch a technician to your location for repairs. If after-hours or emergency service is required, A.C. Dispensing Equipment Inc. will not be responsible for any additional charges.
4. To order parts, call the service center and the appropriate parts will be sent to your location or that of the servicing agency.

The following conditions are not covered by this Warranty:

- Equipment failure related to improper installation, improper utility connection or supply, and problems due to ventilation.
- Equipment that has not been properly maintained, calibration of controls, adjustments, damage from improper cleaning, and water damage to controls.
- Equipment that has not been used in an appropriate manner, or has been subject to misuse or misapplication, neglect, abuse, accident, alteration, negligence, damage during transit, delivery or installation, fire, flood, riot, or act of God.
- Equipment on which the model number or serial number has been removed or altered.

If the equipment has been changed, altered, modified or repaired by other than a qualified service technician during or after the warranty period, then the manufacturer shall not be liable for any damages to any person or to any property, which may result from the use of the equipment thereafter.

This Warranty does not cover services performed at overtime or premium labour rates. Should service be required at times which normally involve overtime or premium labour rates, the owner shall be charged for the difference between normal service rates and such premium rates. A. C. Dispensing Equipment Inc. does not assume any liability for extended delays in replacing or repairing any items beyond its control.

In all cases, the use of other than A. C. Dispensing Equipment Inc. authorized OEM replacement parts will void this Warranty.

This equipment is intended for commercial use only. Warranty is void if equipment is installed in other than commercial applications.

THE FOREGOING WARRANTY IS IN LIEU OF ANY AND ALL OTHER WARRANTIES EXPRESSED OR IMPLIED, INCLUDING ANY IMPLIED WARRANTY OF MERCHANTABILITY OR FITNESS AND CONSTITUTES THE ENTIRE LIABILITY OF A. C. DISPENSING EQUIPMENT INC. IN NO EVENT DOES THE LIMITED WARRANTY EXTEND BEYOND THE TERMS STATED HEREIN.

A.C. Dispensing Equipment Inc.
100 Dispensing Way
Sackville
Nova Scotia, Canada
B4C 4H2



