

AC2-GP

Multi-Sweetener Dispenser

SureShot
multi-sweetener

Service Manual



D-19-123 RevA



**AC2-GP
Multi-Sweetener Dispenser**

SureShot *multi-sweetener*

FEATURES:

- Easy to install – plug in, load, dispense
- Easy refill and service
- Accurate, preprogrammed, consistent portions
- Drink Count Data available
- Clean dispense – quick cutoff avoids messy spills
- Dispenses two products
- Feet are moveable to slide under neighboring appliances

TABLE OF CONTENTS

The Dispenser	1
Main Components	1
Specifications	1
Safety Precautions	2
Operating Instructions	2
Service and Warranty.....	2
Reshipment	2
Troubleshooting	3
Replacement Parts	3
Remove and Install Components	8
Tools Required	8
Auger Motor	8
Power Supply	11
Transition Pieces	12
Repositioning or Replacing the Door.....	13
Door Cable Assembly.....	14
External Power Supply Connector PCB	15
Power Entry Module and Harnesses.....	16
Replace Motor Cable Assemblies	17
Reprogramming Using a FOB	18
Accessing the Program	19
Appendix 1	21
Assembly Diagram and Service Parts Lists ..	21
Appendix 2	26
Wiring Diagram.....	26



SureShot Technical Assistance Center
1-888-777-9990 or 902-865-9602

service@sureshotdispensing.com
parts@sureshotdispensing.com
www.sureshotdispensing.com

A.C. Dispensing Equipment Inc.
100 Dispensing Way
Lower Sackville, Nova Scotia
Canada B4C 4H2





MULTI-SWEETENER DISPENSER SERVICE MANUAL

Important: Read this Manual now and retain it for future reference

THE DISPENSER

The SureShot Dispensing Systems® AC2-GP Multi-Sweetener Dispenser automatically dispenses controlled portions of two dry products such as sugar and other alternative products for use in coffee, milkshakes, hot chocolate, health drinks and other beverages. The product is dispensed by touching selection buttons on the front of the dispenser.

The dispenser has been preconfigured to industry-standard defaults. Each button press is preset independently to accurately dispense a specified amount of product using our unique, state-of-the-art microprocessor technology. The products to dispense are contained in product hoppers inside the dispenser. The auger style dispense system is designed to work with dry products with similar consistency to sugar granules.

MAIN COMPONENTS



Program Mode Buttons

- Program Mode
- ★ Adjustment Up
- Adjustment Down
- Panel Disable

SPECIFICATIONS

Weight:	29.0 lbs/13.2 kg (empty dispenser)
Dimensions (DxWxH):	17.75" x 4.0" x 24" (without feet) Dispenser height varies with feet selection
Hopper Capacity:	Top Hopper 6.0 lbs/2.7 kg (granular sugar) Bottom Hopper 2.5 lbs/1.1 kg (granular sugar)
Electrical Requirement:	100-240 VAC, 0.5 amps Max. 50-60Hz, 1 ph

AC2-GP

Dispenser may not be exactly as shown

SAFETY PRECAUTIONS

- Always plug the dispenser into an approved electrical outlet.
- The dispenser includes a microcontroller and must be operated on grounded electrical wiring at all times.
- Unless otherwise specified in the procedure, the dispenser should be unplugged from its electrical source before servicing.
- Do not immerse the dispenser in water.
- Observe all safety precautions with this dispenser that you would with any electrical appliance.
- The dispense auger is powered by a motor with a turning shaft. To avoid possible injury or equipment damage, keep hands and objects clear of the auger and shaft when equipment is plugged in.

OPERATING INSTRUCTIONS

For all operating procedures and instructions refer to the operations manual specific to the dispenser being serviced. For general operating instructions refer to manual D-19-090.

SERVICE AND WARRANTY

Standard warranty is one year, on-site parts and labour (unless otherwise negotiated). Access to USA and Canada-wide Technical Service Network.

The Warranty will be null and void if the dispenser is serviced by unqualified personnel. Under warranty, service technicians must be approved and dispatched by the SureShot Technical Assistance Center.

During the warrantee period, the SureShot Technical Assistance Center must be contacted at 1-888-777-9990 or 902-865-9602 for approval of any proposed service before commencing.

The customer is responsible for all costs not approved by SureShot Dispensing Systems®.

Note: the Serial Number and Option Code of your dispenser are located on the Product Identification Label on the back of the unit. Please refer to these numbers when contacting the SureShot Technical Assistance Center. These numbers are crucial in helping us provide prompt and effective service. This will save you time.

RESHIPMENT

No returns will be accepted without prior approval. Obtain a Return Materials Authorization (RMA) number by contacting the SureShot Technical Assistance Center at 1-888-777-9990 or 902-865-9602.

Ensure pieces which may shift in transit are secured using masking tape.

If packaging is not available, it may be purchased from the SureShot Parts Department by calling 1-888-777-9990 or 902-865-9602.

TROUBLESHOOTING

The following trouble-shooting guide is intended to assist in tracking down some of the simpler and/or more commonly occurring issues. Any actions or suggested replacement parts represent possible causes and solutions only and are not guaranteed to correct the observed issue. If there are any questions regarding either the procedures or the replacement parts required, please contact the SureShot Technical Assistance Center at 1-888-777-9990 or 902-865-9602.

Replacement Parts

To determine replacement parts, refer to Appendix 1 on page 21.

Note: *The Serial Number and Option Code of the unit must be included with the order information for many of the replacement parts. Both are located on the Product Identification Label on the back of the unit.*

Problem	Action
<p>Dispenser does not turn on (LCD remains blank after plugging in the unit and none of the buttons function).</p>	<p>The inability to turn on is an indication that either power is not reaching the control circuit board in the door or the door itself is defective. Follow through the steps described below to isolate the issue. Check unit functionality after each step and repair defect or replace parts as required.</p> <ol style="list-style-type: none"> 1. Check to ensure that the wall outlet is functioning. 2. Check that all external power cord(s) are completely and securely connected at all points. 3. On Units with an external power supply¹: <ol style="list-style-type: none"> a. Verify that the retaining nut on the power feed-through on the back of the unit is fully installed. (If the nut has backed-off it may prevent full connector engagement.) b. Verify that the connection from the power cord to the jack on the back of the unit is secure by trying to move the connector. If the power comes on for any length of time then the connection is poor. If the connector cannot be tightened further then the power entry PCB may have to be replaced (see page 15). c. Verify supply functionality – remove the power cord jack from the back of the unit and using a volt-meter verify that there is 12 VDC at the power supply by probing the connector jack. If 12 VDC is present, re-connect to machine. 4. Check that the door cable is completely and securely connected to the circuit board in the door. To do this: <ol style="list-style-type: none"> a. Open the front door and remove door wire grommet b. Gently tug on door cable to ensure secure connection. 5. With the unit powered on, verify power at door connector – open door, remove door connector and confirm that voltage across pins 1 (or 2) and 4 (or 5) is 12 VDC. If there is power on the cable connector but the door does not function when properly connected, then the door may require replacement.

¹ On units with Serial Number XXXX-003874 and lower the power supply is an external type as shown on page 11. After that serial number the power supplies were installed inside the unit.

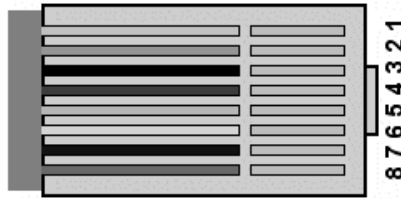

Note: attachments to multi-meter probes may be required to access connector contacts.

6. If there is no power at the door connector then trace back to where the power is lost. To do this remove the right side panel (preferred) or left side panel as viewed from the front of the unit.
7. **On Units with an internal power supply:**
Caution: the power supply and input connections are 110 VAC.
 - a. Ensure that all connections to the power supply and power entry module are in place and secure.
 - b. Remove the input connector (with black and white wires) and verify the voltage at the output of the wiring harness is 110 VAC. If there is no voltage then either the power cord, the power entry module or the power wire harness is defective and may need to be replaced. Examine each further as required to find the defective part.
 - c. Replace the power supply input connector and remove the output connector on the top of the power supply. Check that the voltage on the power supply output pins is 12 VDC. If the power is present at the input but not at the output then the power supply may need to be replaced.

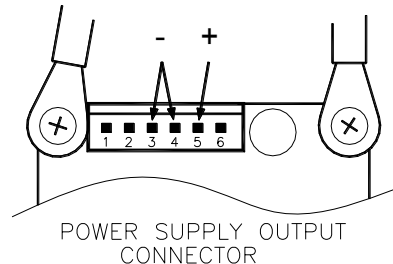

8. **On Units with an external power supply:**
 - a. Check the integrity of each connector and examine the wires for breaks or other damage. If the integrity is unclear, replace with new wire to see if problem is corrected. Replace as required.
 - b. Check the power availability of each connector in turn using the diagram shown in step 5 as a guide. As can be seen with the side panel removed, the wiring is a sequential series of wires with RJ45 connectors at each end. A break in connection at any point eliminates power (or communication) from propagating to any points "downstream" of the break. Replace any damaged wires or components as required.

<p>Dispenser resets intermittently (goes through power-up sequence)</p>	<p>The intermittent resetting of a unit is usually an indication of a faulty connection somewhere between the power supply and the control PCB in the door. To find the fault:</p>
---	--

	<ol style="list-style-type: none"> 1. Check all connections in line with door power (see “Dispenser does not turn on” troubleshooting section above) and verify that they are completely and securely connected. Repair or replace any defective parts as required. 2. If all connections are secure and symptoms recur without any connections being compromised then the issue is likely to be either a faulty power supply or an intermittent connection on the PCB in the door. 3. If possible, replace the power supply with one that is known to function properly and verify that intermittency disappears. If it is still present then the intermittency is likely in the door and the door may need replacement (see Page 13).
<p>Button panel “locks-up” or functions unpredictably</p>	<p>As the unit is controlled by a micro-controller it is possible that under some conditions (such as power surges or brown-outs) that a part of the program becomes corrupted. To correct this condition:</p> <ol style="list-style-type: none"> 1. Reset the unit by unplugging and re-connecting power. If problem persists then continue to next step. 2. If this is not the issue and the problem persists the unit should be re-programmed using a FOB (see page 18). 3. If the problem is still not corrected then the issue is a likely to be a defective PCB and the door may have to be replaced (see page 13).
<p>LCD display is blank (or all black squares) but unit continues to function normally otherwise.</p>	<p>An LCD that does not display properly may be caused by either a defective LCD module or a faulty program. To determine the likely cause:</p> <ol style="list-style-type: none"> 1. Reset the unit by unplugging and re-connecting power. If the LCD continues to show a blank including during the power-up sequence (during Reset) then the LCD is defective and the door may need to be replaced. If the LCD does display characters during the power-up sequence but not once the reset is complete then continue to next step. 2. Re-program the unit using a FOB to over-write the corrupted program with a new one.
<p>Unit dispenses incorrect amount of product.</p>	<p>There can be several causes for the unit to dispense incorrect amounts of product. The following steps should be followed to diagnose and correct this issue:</p> <ol style="list-style-type: none"> 1. Ensure that unit is set up and being operated correctly: <ol style="list-style-type: none"> a. Ensure that hopper contains adequate amount of product - the hopper should be filled at least to the low level mark. b. Ensure that the hopper is securely positioned in the unit and properly engaged with the motor coupler (See Loading Hoppers in Operational Manual) c. Ensure all required selections have been made: Beverage Type, Product Selection, Size etc. d. Ensure that the dispense Target is set correctly (refer to Operations Manual if required). e. Ensure that the correct Product type has been selected in the program (refer to Operations Manual if required). f. Ensure that the Volume Adjust is correct. (The factory default is zero but it may be altered to compensate for local variations of the product - refer to Operations Manual if required). g. Ensure that the product delivery tubes are not twisted, kinked, pinched-off or blocked.

2. Reset the unit by unplugging and re-connecting power.
3. Verify that the auger is clean and is able to move freely by removing the hopper and manually rotating the auger.
4. Ensure that the motor coupler is securely attached to the motor shaft by removing the hopper and twisting it. If the coupler is firmly attached, the motor/gearbox can be heard and felt to rotate. If it is loose it may rotate freely or pull off easily and should be corrected by tightening the coupler attachment screw.

Note: When installing or tightening a coupler, make sure that the coupler is pushed back to the plastic spacer but not tight enough to restrict the coupler from rotating freely.

Note: In newer models the coupler can only be installed with the clamping screw parallel to the flat side of the shaft.

5. If the coupler does not rotate smoothly and freely then it is possible that the motor/gearbox assembly is damaged and may need to be replaced. To verify this, re-position the coupler by loosening and re-tightening it as described in the note above. If the coupler is still unable to turn then the motor assembly may have to be replaced.
6. Ensure that the motor is securely attached to the chassis by trying to move the coupler side-to-side with the hopper removed. If it is loose, tighten it and retest.

If the “*Dispensing...*” message persists for several seconds after the dispense cycle has completed it is an indication that the rotary encoder on the back of the motor assembly has become loose. To verify that this is the problem:

7. Try dispensing several sizes of the same product. If the rotary encoder is loose then all sizes will dispense approximately the same amount of product. Also, the dispense cycle sounds different. Rather than a sharp starting and stopping of the motor, the motor stops slowly over a second or two at the end of dispense. In addition, in units where the motors have a reverse rotation at the end of dispense, the reverse portion of the dispense cycle is missing which can be heard by the lack of the extra motor activation at the end of each dispense.
8. Remove the left or right side cover and remove the hopper.
9. Holding the motor coupler with one hand, try moving the disk on the rear of the motor shaft. It should only allow a small amount of rotation before the coupler turns (the gearbox has a 10:1 ratio) and it should not permit any axial movement on the shaft. See Figure 6 on page 9 for view of rotary encoder.

Note: Care should be taken not to disrupt the dipswitch on the motor circuit card as any change in the dipswitch settings will cause the unit to malfunction. The dipswitch is on the left hand side of the card (as viewed from the front of the unit looking back) near the bottom of the card. See page 9 for illustration of dipswitch.

If this examination is inconclusive the motor may need to be removed for closer examination. If the rotary encoder is loose the motor assembly will have to be replaced.

<p>Dispenser behaves erratically... either:</p> <ol style="list-style-type: none"> 1. opposite product dispenses from the one selected, 2. both products dispense at same time, 3. neither product dispenses, 4. the same product dispenses regardless of product selection, or 5. unit continually resets when dispense button is pressed. 	<p>If any or several of these symptoms appear after a motor replacement or other service work has been performed it may be due to an incorrect dipswitch setting on a motor driver circuit card (See Figure 6 on page 9). The dipswitches are used by the controlling software to identify each motor separately on the communication bus. To determine whether this is the issue and to correct it:</p> <ol style="list-style-type: none"> 1. Remove the <i>left</i> side panel (as viewed looking at the front of the unit). 2. Examine dipswitch settings (See Page 9 for setting details) and confirm that they are correct according to the diagram. 3. If one or both are not set as shown in the diagram, correct using a fine-tipped object such as a ball point pen. Once reset the unit must be re-booted by powering down / up again. 4. If the problem persists, the motor driver program may have been corrupted. Re-program the driver using 'Driver DL Force' as described on page 19. 5. If the problem persists it is possible that the dipswitch itself is defective. To help identify this situation, change the dipswitch setting on one of the motor assemblies to an unrecognized address by toggling switch 3 or 4 to the "on" position. This makes sure that the motor will not respond to any dispense signals and leave the other motor free to respond normally without interference from the first motor. If this corrects the issue then the first motor assembly may be defective and may need to be replaced.
<p>Dispenser accumulates product inside the unit.</p>	<p>An accumulation of product inside the unit around the bottom of either hopper can be caused by several things. To identify the cause and to correct:</p> <ol style="list-style-type: none"> 1. If the unit is a "Fill-in-Place" unit (with removable top cover), verify that the transition piece (see Appendix 1) on the top of the unit is present and seated properly. This part forms a funnel to direct the product into the top hopper. If not present, product can leak past the hopper to the inside of the unit. Replace or reposition if required. 2. Check the product delivery tubes for any breaks and for proper attachment to the hoppers. Re-attach or replace if required. <p>If the product accumulation is around the back of the hopper (around the motor coupler) it may be an indication that the auger shaft or auger bushing is worn, enabling product to leak out the rear of the hopper. To confirm this diagnosis and to correct the issue:</p> <ol style="list-style-type: none"> 3. Remove the hopper assembly and examine the fit of the auger in the rear of the hopper assembly. It should be snug with no sideways play in the bushing. If sideways play is present then the auger assembly may have to be replaced.
<p>Button panel "locks-up" (LCD is ON but none of the buttons function)</p>	<p>The dispenser is controlled by a micro-controller and may be subject to temporary disruption by some types of power anomalies. If the button panel "locks-up" it is an indication that the micro-controller operation has been corrupted. If this happens all functions stop working. To correct this issue:</p> <ol style="list-style-type: none"> 1. Unplug the dispenser, wait 10 seconds, then plug the dispenser back in. This resets the microcontroller. 2. If this does not correct the issue then the program itself may have become corrupted and the unit may have to be re-programmed using a FOB (See page 18).

<p>The auger motor does not respond to dispense commands (no sound or sign of movement)</p>	<p>The motor is controlled by a software program running on a micro-controller in the motor assembly which in turn is controlled by a micro-controller and software in the door. A non-responsive auger motor can be an indication of several things. To determine the likely cause of the issue and to correct it:</p> <ol style="list-style-type: none"> 1. Remove the hopper assembly and try rotating the coupler by hand. If the coupler either does not rotate at all or requires excessive force then it is likely that the motor assembly has seized and may need replacement (see page 9). 2. If the auger coupler rotates freely then it is possible (although unlikely) that the motor driver software has become corrupted. A copy of the driver software, however, is kept in the door software and can be downloaded to the motor driver chip to correct this issue. To do this follow the Program Mode > Service Page > Driver DL Force instructions on page 19. 3. If the issue persists after successfully re-loading the driver software then the connections and wires between the door and the motor assembly should be checked for signs of damage. Any suspect wires should be checked by installing new wires and replaced as required. 4. If the problem persists then the dipswitch setting should be checked (see page 9 for description of correct settings) 5. If the problem still persists then it is likely that the motor assembly itself is damaged and may have to be replaced.
<p>Door does not stay closed</p>	<p>The door latches when the door latch screw on the top of the door opposite the hinge snaps into the latching hole in the top plate. If the screw is missing or the top plate becomes bent then the latch will not work properly.</p> <ol style="list-style-type: none"> 1. Check to see if the latching screw on the top right hand side of the door is present and secure. Correct as required. 2. If the screw is present and secure and the door still does not latch properly, adjust the top plate position by carefully bending up or down as required. When located correctly, the hole in the top plate should hold the latching screw firmly when the door is closed but allow the door to open and close with comfortable ease.

REMOVE AND INSTALL COMPONENTS

Tools Required

All service procedures can be performed with a minimum of tools as follows:

- Medium sized Phillips screwdriver
- Small sized Phillips screwdriver
- 5/16" wrench
- 10mm wrench
- 3/32" Allen wrench
- 7/64" Allen wrench
- 9/64" Allen wrench
- Multi-meter
- Power Drill
- Rivet Gun



Figure 1

Auger Motor

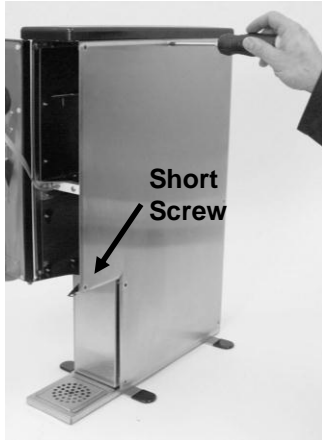

Figure 2



Figure 3



Figure 4



Figure 5

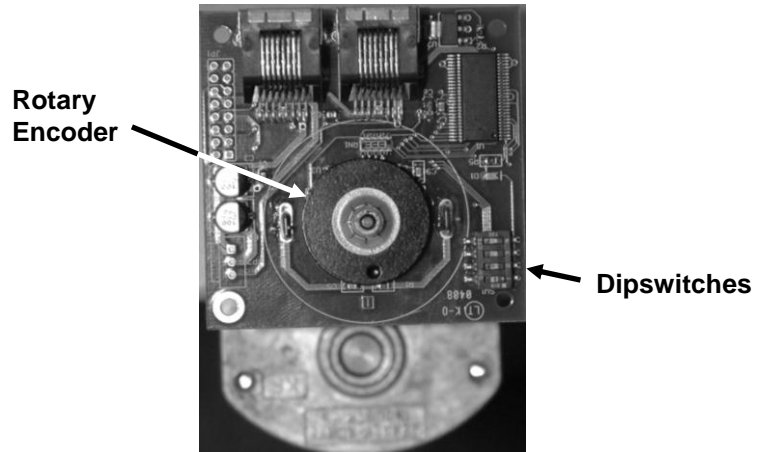

Figure 6

Removal:

1. Unplug power cable from power outlet or from rear of dispenser.
2. Remove the hopper connected to the motor being replaced.
3. Remove either side panel using Phillips screwdriver to remove all the screws holding the side panel on. See Figure 2
4. Unplug the motor connector cables from the back of motor assembly being replaced. See Figure 3.
5. From the inside of the hopper compartment, remove the four 8-32 screws holding the motor in position, using a 9/64" Allen key. See Figure 4.
6. Remove the motor assembly. See Figure 5.
7. Before installing the new motor assembly, make sure that the dipswitches are set correctly as indicated below:



Upper Motor Dipswitch Setting

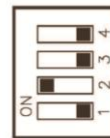

Lower Motor Dipswitch Setting

Note: The dipswitch settings are shown as viewed in Figure 6.

Installation:

8. Replace the motor assembly by installing the four 8-32 screws.

Note: *It is recommended that thread-locker be used on these screws when replacing them.*

9. Plug connector cables back into the connectors located on motor PCB. Care should be taken to ensure that the right cables are re-attached to prevent over-stretching the wires.

10. Install the side panel.

Note: *Short screw located in lower- front location as indicated in Figure 2.*

11. Install hopper

12. Plug power cable back into unit.

Power Supply

Early models of the AC2-GP (Serial Numbers XXXX-003874 and earlier) were equipped with an external power supply as shown in Figure 7 below. Later models have the power supply mounted inside the unit on the lower part of the back panel. To replace the power supply follow the directions for the type being serviced.

External Power Supply:



Figure 7

Removal:

1. Unplug the power supply from the wall and disconnect from the back of the unit.

Installation:

1. Ensure that all cords are completely and securely connected together.
2. Plug the cord connecting the power supply to the dispenser into the back of the dispenser and fully tighten the screw-lock.
3. Plug the other cord from the power supply into the wall outlet.

Internal Power Supply:

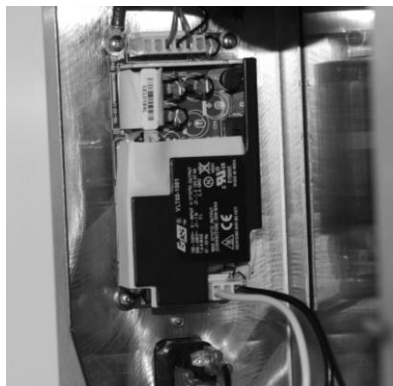

Figure 8

Removal:

1. Unplug power cable from power outlet or from rear of dispenser.
2. Remove either the left or the right side panels from the unit.
3. Unplug the input and output connectors from the power supply.
4. Unscrew the four corner screws using the small sized Phillips screwdriver.

Installation:

5. Hold the new power supply into place and install the bottom two screws.
6. Install each of the upper screws ensuring to replace grounding lugs, one under the head of each mounting screw.
7. Plug the output (12 VDC) and input (110 VAC) connectors into the top and bottom of the power supply respectively.
8. Replace the side panel – make sure to replace the short screw in the correct location (see Figure 2 on page 9).
9. Plug power cable into outlet.

Transition Pieces



Figure 9



Figure 10



Figure 11

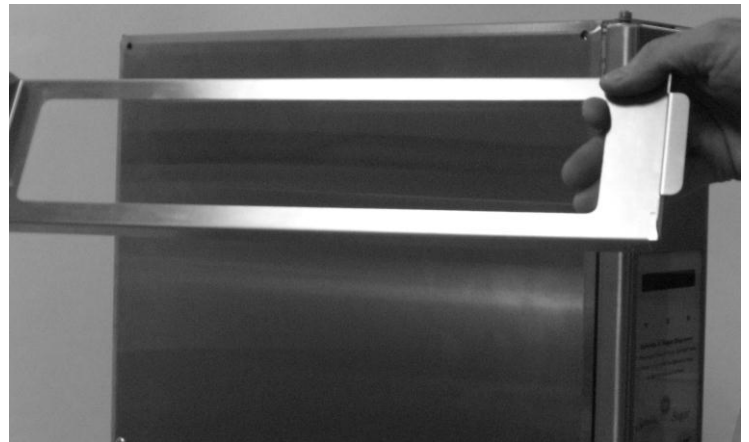

Figure 12

Removal:

1. Remove the plastic top lifting it up and off. See Figure 9
2. Remove the plastic transition piece by lifting it up and out of the stainless steel transition. See Figure 10
3. Remove the screws holding on the Stainless steel transition using a Phillips screw driver. See Figure 11
4. Lift off the Stainless steel transition by lifting it up and off. See Figure 12

Installation:

5. Install new Stainless steel transition over the side panels and install screws. Make sure to install the short screw in the location indicated.
6. Replace plastic parts onto unit.

Repositioning or Replacing the Door



Figure 13

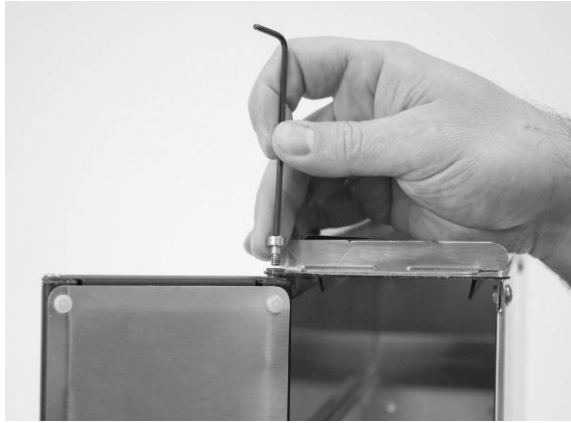

Figure 14



Figure 15



Figure 16

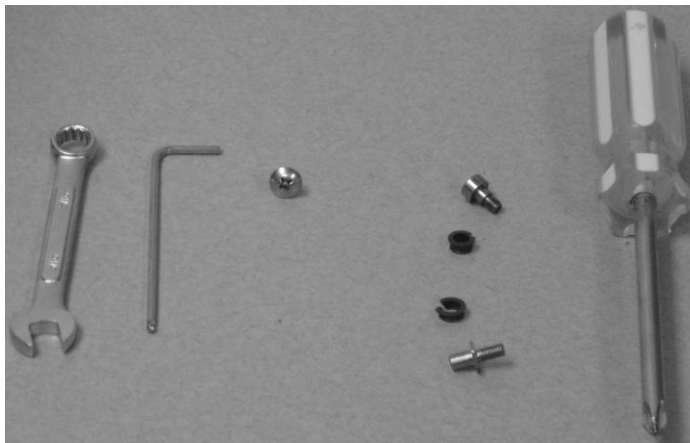

Figure 17



Figure 18

Removal:

1. Open the dispenser door fully (180°). See Figure 13.
2. Remove door cable from clamp and pop out the black grommet from the door. See Figure 13
3. Unplug the door cable from behind the grommet.
4. Lift the top off the dispenser.
5. Remove the fastener from the top of the door, using a 3/32 Allen key. See Figure 14. Hold onto door when removing fastener. See Figure 15. Retain fastener for installation.

Steps 6 to 11 Optional for door swing direction

6. If repositioning door hinge to swing in opposite direction, remove the screw in the cable locator plate. See Figure 16.
7. Remove Phillips screw from top of door using Phillips screw driver. See Figure 17.
8. Remove hinge standoff from bottom of door using 5/16" wrench. See Figure 17.
9. Remove the 2 grommets from chassis. See Figure 17.
10. Install all the removed fasteners and hardware on the opposite side from which they were removed.
11. Flip cable and locator plate to position cable on opposite side of chassis. See Figure 18.

Installation:

12. Install the new door with fastener. See Figure 18
13. Plug in the cable removed and replace the grommet. See Figure 18
14. Close door.

Door Cable Assembly



Figure 19



Figure 20



Figure 21

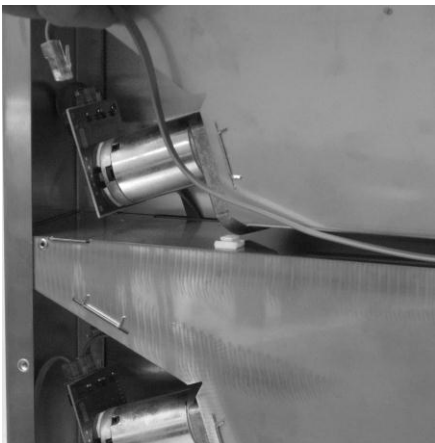

Figure 22



Figure 23



Figure 24

Removal:

1. Unplug power cable from power outlet or from rear of dispenser See Figure 19
2. Remove top hopper to make access to cable locator easier. See Figure 20
3. Remove left side panel by using a Phillips screwdriver to remove all the screws holding the side panel on. See Figure 21
4. Unplug the door cable connector from the back of top motor assembly located closest to left hand side. See Figure 22
5. Remove the cable from the cable clamp located under the upper hopper compartment. See Figure 22
6. Remove door cable from clamp and pop out the black grommet from the door. See Figure 23
7. Unplug the door cable from behind the grommet. See Figure 23
8. Remove the cable locator screw using Phillips screw driver. See Figure 23. Retain screw for replacement cable assembly.
9. Remove the door cable assembly through the front of the unit. See Figure 24

Installation:

10. Reverse the sequence to install the replacement cable assembly.
Note: Make sure cable connector with grommet end is out when replacing new cable.
Note: Short screw located at front in lower hopper location. (See Figure 2 on page 9).

11. Plug power cable into outlet.

External Power Supply Connector PCB (For units with external power supplies only)



Figure 25

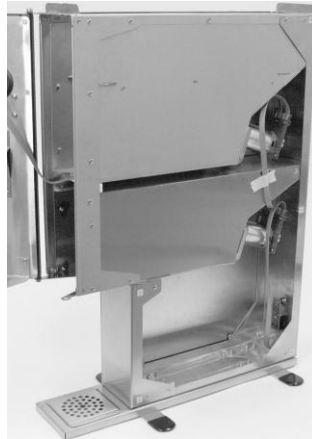

Figure 26

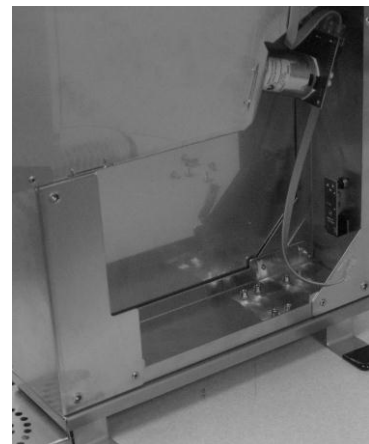

Figure 27



Figure 28

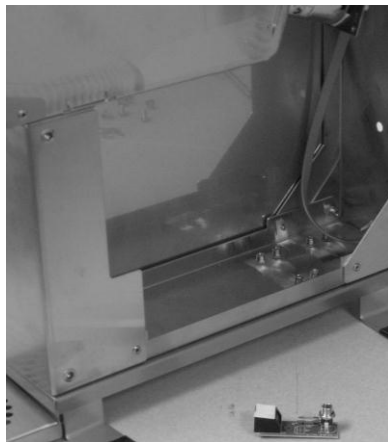

Figure 29

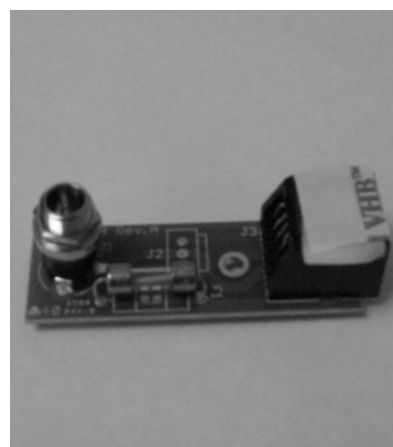

Figure 30

Removal:

1. Unplug power cable from power outlet or from rear of dispenser. See Figure 25
2. Remove either side panel by using a Phillips screwdriver to remove all the screws holding the side panel on. See Figure 26
3. Disconnect the cable from the power supply PCB assembly. See Figure 27
4. Remove nut from connector at rear of dispenser using a 10mm wrench. See Figure 28
5. Remove the power supply PCB assembly by gently pulling to detach the mounting tape from the frame. See Figure 29.

Installation:

6. Remove retaining nut and adhesive protective backing on new power supply assembly and position into frame.
7. Replace the nut onto new connector.
8. Connect the cable to the power supply assembly.
9. Position the side panel onto the frame and replace screws.

Note: Short screw located at front in lower hopper location (See Figure 2 on page 9).

10. Reconnect power supply.
11. Plug power cable into outlet.

Power Entry Module and Harnesses

(For units with internal power supplies only)

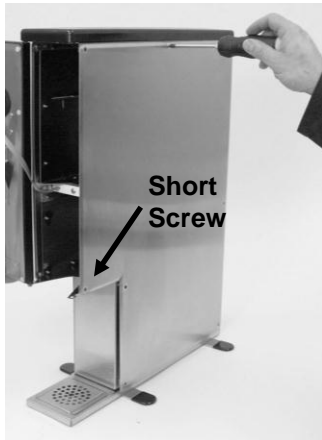

Figure 31



Figure 32



Figure 33



Figure 34



Figure 35

Removal:

1. Unplug unit from the wall.
2. Remove either side panel by using a Phillips screwdriver to remove all the screws holding the side panel on. See Figure 31
3. Unplug the power cord from the unit. See Figure 32.
4. Disconnect the wiring harness connectors from the power entry module (and from the power supply if the harness is being replaced). See Figure 33.
5. Remove the power entry module by drilling out the fastening rivets from the rear of the unit. Pliers may be needed to hold the end of the rivet on the inside of the unit to prevent it from rotating. See Figure 34.

Installation:

6. Rivet a new power entry module into place using 1/8" diameter, domed, stainless steel pop rivets with a 0.18" grip. Ensure to install the module in orientation as shown to avoid confusing the wire connections.
Note: *Alternatively, the power entry module can be installed using 4-40 stainless machine screws with a nut and washer on the inside.*
7. Replace the power wiring harness and ground wire.
8. Position the side panel onto the frame and replace screws. Make sure to install the short screw in the location indicated.
9. Plug power cable into back of unit and into outlet.

Replace Motor Cable Assemblies



Figure 36



Figure 37



Figure 38

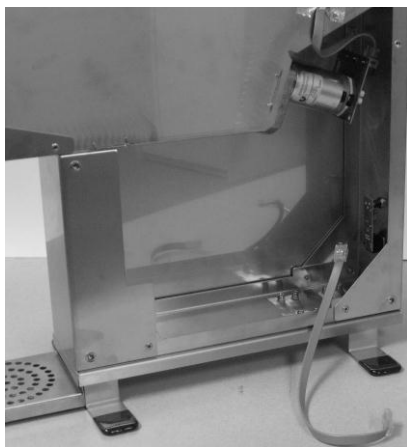

Figure 39

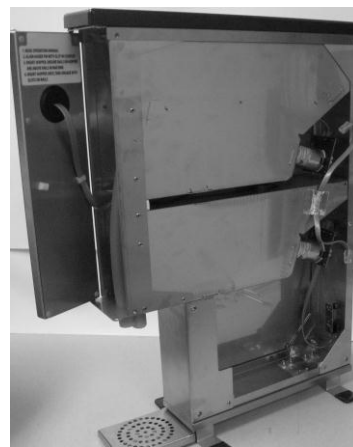

Figure 40

Removal:

1. Unplug power cable from power outlet or from rear of dispenser. See Figure 36
2. Remove either side panel by using a Phillips screwdriver to remove all the screws holding the side panel on. See Figure 37

To remove power supply cable (p/n: A-10-024-4):

3. Disconnect the cable from the power supply PCB assembly. See Figure 38
4. Disconnect and remove the cable from the bottom motor/PCB assembly. See Figure 39

To remove power supply cable (p/n: A-10-060):

5. Disconnect and remove the cable from the bottom motor/PCB assembly. See Figure 40
6. Follow the cable from the bottom motor/PCB assembly to the top motor/PCB and disconnect the cable from PCB. See Figure 40

Installation:

7. Replace removed cable assembly to the position it was removed from. The cable can be plugged in either direction.
8. Position the side panel onto the frame and replace screws.

Note: Short screws located at front in lower hopper location on both sides (See Figure 2 on page 9).

9. Plug power cable into outlet.

Reprogramming Using a FOB



Figure 41



Figure 42

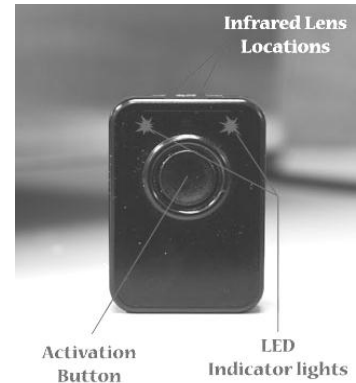

Figure 43

The dispenser can be re-programmed using a battery powered Program Transfer Device (FOB) available from SureShot Dispensing Systems®.

To re-program the dispenser with a FOB follow these instructions:

1. Press and hold the panel disable button on the door for approximately 3 seconds until "Panel Disabled" appears in the LCD. The button panel LED's will flash in groups when the button is released.
Note: *Alternatively the unit may be programmed during power-up. In this case, turn power off and then turn on again. When the unit is turned back on, the FOB should be held in place and immediately activated. Continue to follow steps 2, 3 and 4.*
2. Aim the FOB at the infrared window (red rectangle below the selection buttons – see Figure 42), then press and release the activation button on the FOB. When aimed correctly, the *left* LED on the FOB illuminates indicating that it is communicating correctly. The LCD display on the door will read "IR" when downloading starts. You will also see LED's flash on and off on the button panel.
Note: *If the right LED on the FOB illuminates, move the FOB slightly to re-align it with the infrared window on the door. Once re-aligned, the right LED will turn off while the left LED should remain lit. If both LED's turn off then the FOB requires re-activation by pressing the activation button.*
3. Hold the FOB in place until the left LED on the FOB blinks approximately 4 times in succession (after approximately 1 minute). Remove the FOB at this time.
Note: *If both FOB LEDs turn off before completing Step 3, it is necessary to return to Step 2.*
4. Wait for approximately 1 minute until the initializing process has been completed and "Make Selection" appears in the LCD. **DO NOT POWER DOWN THE UNIT UNTIL INITIALIZATION IS COMPLETE.**
Note: *in some program versions, the initialization process ends with 'OK ..' appearing on the LCD. On these units, once the 'OK ..' message appears either press the ■ Program Mode button or re-boot the machine (power off / on) to return to normal operating mode where 'Make Selection' appears in the LCD.*

ACCESSING THE PROGRAM

In order to access the variables and functions available in the software, the Multi-Sweetener™ Dispenser provides two program access modes: “Maintenance Mode” and “Program Mode”. Maintenance Mode is designed to allow easy access to commonly used features including the Volume Adjust feature and Drink Count data. Functions which are used less frequently and normally more restricted are accessed using Program Mode. These modes are available for both store level use as well as to assist in various trouble-shooting and repair procedures. This section describes the program features available in the Program Mode > P4: Service page that are included for various service operations. For descriptions of all other Maintenance Mode and Program Mode functions refer to the Operations Manual.

Note: *In older models there is only a single Program Mode which contains all function accesses. In these models, the Program Mode is accessed by pressing the ■ Program Mode button and holding it for several seconds until a double beep is heard.*

To Access Program Mode:

1. Press the ● Panel Disable button for several seconds until you hear the second beep, then release. When the button is released, the words “Panel Disabled” appear in the LCD and the LEDs on the button panel flash in a cycling pattern.
2. While in Panel Disable mode, press and hold the ■ Program Mode button for several seconds until you hear the second beep and the words *Program Mode* appear momentarily in the LCD.
3. Once in Program Mode press the ■ Program Mode button repeatedly until the LCD displays the required page. In this manual, only the Service page (P4: Service) is described.
4. To exit Program Mode press the ■ Program Mode button and hold for several seconds until there are two rapid beeps and Make Selection displays in the LCD.

Note: *Program Mode times-out from most program pages and returns to normal operation mode after approximately 3 minutes of inactivity.*

P4: Service

When in the Service page, several functions are available to assist in trouble-shooting and other service related activities. To determine the button location of a particular function, press each button momentarily and its function will be displayed in the LCD. Descriptions of the various Service page functions are detailed below.

Driver DL Force: (Forced Driver Download) Each auger motor assembly comes with a micro-controller programmed with a software driver to control the motor. The program in the door has a copy of the motor driver which can be downloaded to the motor micro-controllers if required. To activate this function, press the Driver DL Force button for approximately 8 seconds until several beeps are heard. The LCD will then change to read: ‘PRG’ followed by the driver download status (the first character represents the top motor driver). There are three status symbols:

- “–” indicates software download initiated
- “X” indicates software down load in progress
- “.” Indicates software download complete
- “^” indicates that the download has failed

Initially, therefore, the LCD will read: ‘PRG – X’

Upon successful completion of the download the LCD will read: “OK . . .”. If the download of one of the motor drivers fails then the following should be done:

- Try downloading the drivers again following the same procedure
- If still unsuccessful check the address switches on the auger motor PCB (see page 9)
- Check the interconnect wires and connectors to make sure that they are secure and not damaged
- Correct deficiencies as required.

Driver DL: (Driver Download) This function is similar to the 'Driver DL Force' function described above but does a comparison between the version in the door and the versions in both motor driver chips. It then only downloads the driver from the door if it is a newer version. All the status indications are the same as described in 'Driver DL Force' above.

LED Test: This function illuminates all of the button panel LEDs simultaneously and is used to verify the functionality of the LEDs. To activate this feature, press and hold the LED Test button for several seconds until a double beep is heard. Once released, the button panel LEDs should illuminate.
To turn off the LEDs the unit must be unplugged and re-started.

BP Download: (Button Panel Download) This function may be used to download new software using a program transfer device (FOB). To activate this function, press and hold the 'BP Download' button for approximately 10 seconds until there is a double beep and the words 'Align IR FOB' appear in the LCD. Once this occurs, the FOB should be held in place and the process continued as described on page 18.

Note: *Once this feature has been activated the unit will wait for a FOB indefinitely. To exit this mode without FOBing the unit the dispenser must be unplugged and re-started.*

Software: This function allows the user to view the versions of software currently loaded into the unit. To activate this feature, press and hold the 'Software' button until a double beep is heard.

Note: *Once activated, the unit will not timeout from 'Program Mode' automatically and the various software versions must be scrolled through to completion. Alternatively, the unit can be unplugged and re-started.*

Once initiated the LCD scrolls through the various software locations, listing the software numbers and versions resident in those locations. The locations include:

Door SW:	Micro-controller on the circuit board in the Door A ESW... (A signifies Application code) B ESW... (B signifies Bootloader code)
Door PCB 3:	s/n chip on door circuit board (un-used)
Pump 1 SW:	Motor driver chip on top motor PCB A ESW... (A signifies Application code) B ESW... (B signifies Bootloader code)
PCB 6	s/n chip on motor driver circuit board
Pump 2 SW:	Motor driver chip on bottom motor PCB A ESW... (A signifies Application code) B ESW... (B signifies Bootloader code)
PCB 6	s/n chip on motor driver circuit board

Once all software numbers have been scrolled through, the LCD display appears blank. Press the 'Software' button once more to go to the beginning of the 'Software' page. From here 'Program Mode' can be changed to the next page or exited.

Defaults: This function allows the user to reset the dispenser software back to the original factory values. To activate this feature, press and hold the button for approximately 3 seconds until a double beep is heard. After a moment the LCD should read 'Done' indicating that the reset has been completed.

Note: *The use of this function will over-write all previously entered values including drink counts.*

APPENDIX 1

General Assembly Diagram and Service Parts Lists

Part numbers and descriptions for ballooned items provided on page 25.

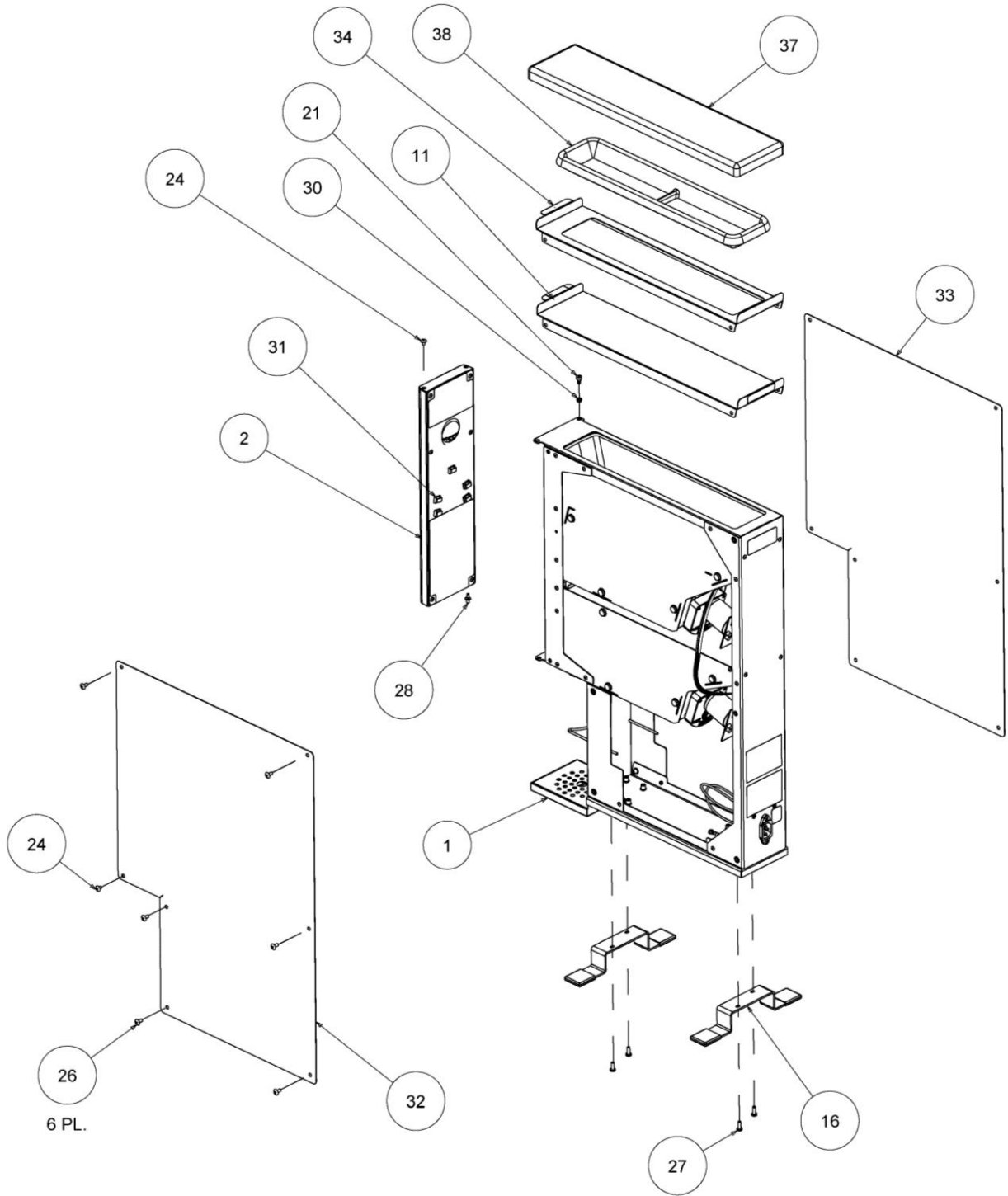

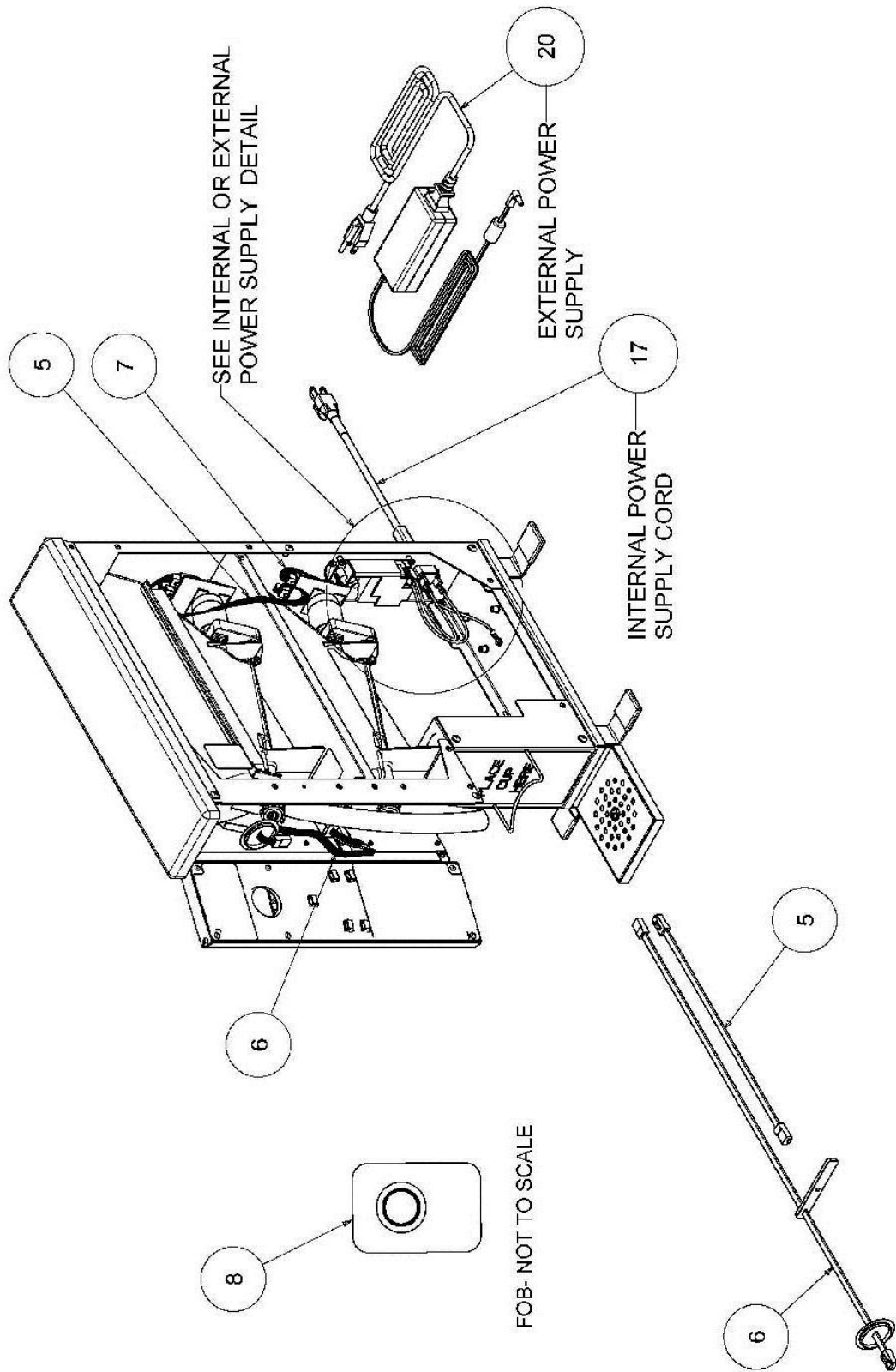

External Power Supply:

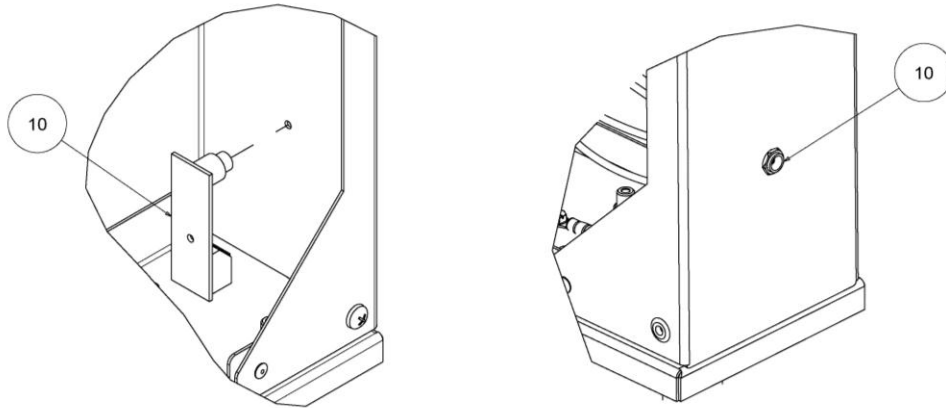

Internal Power Supply:

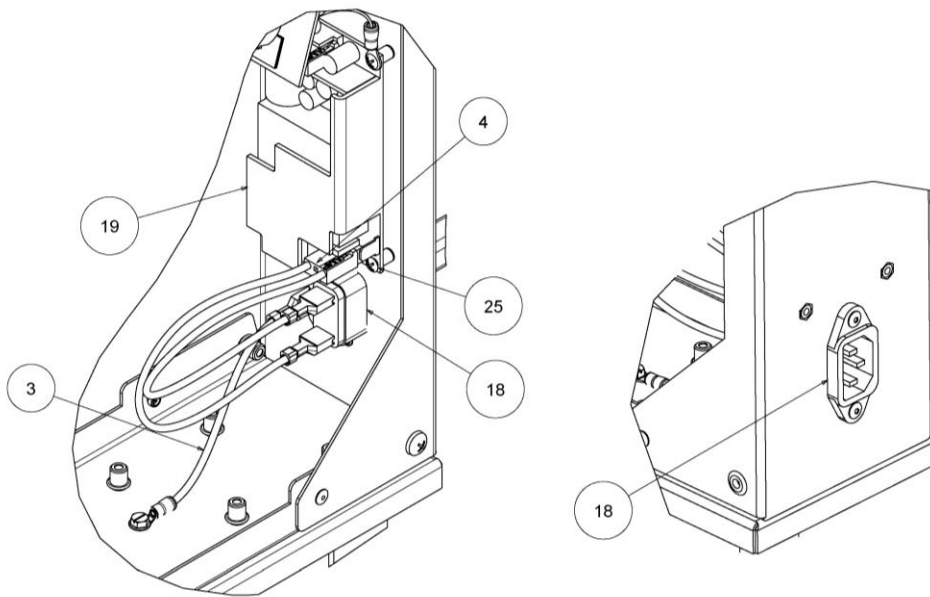

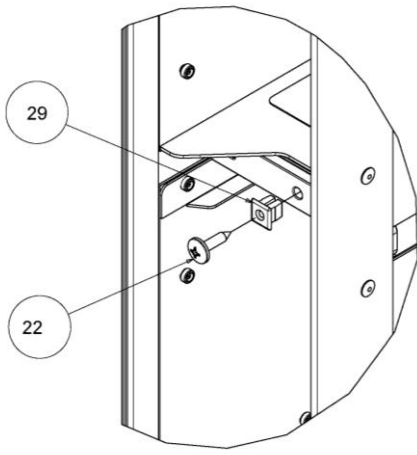
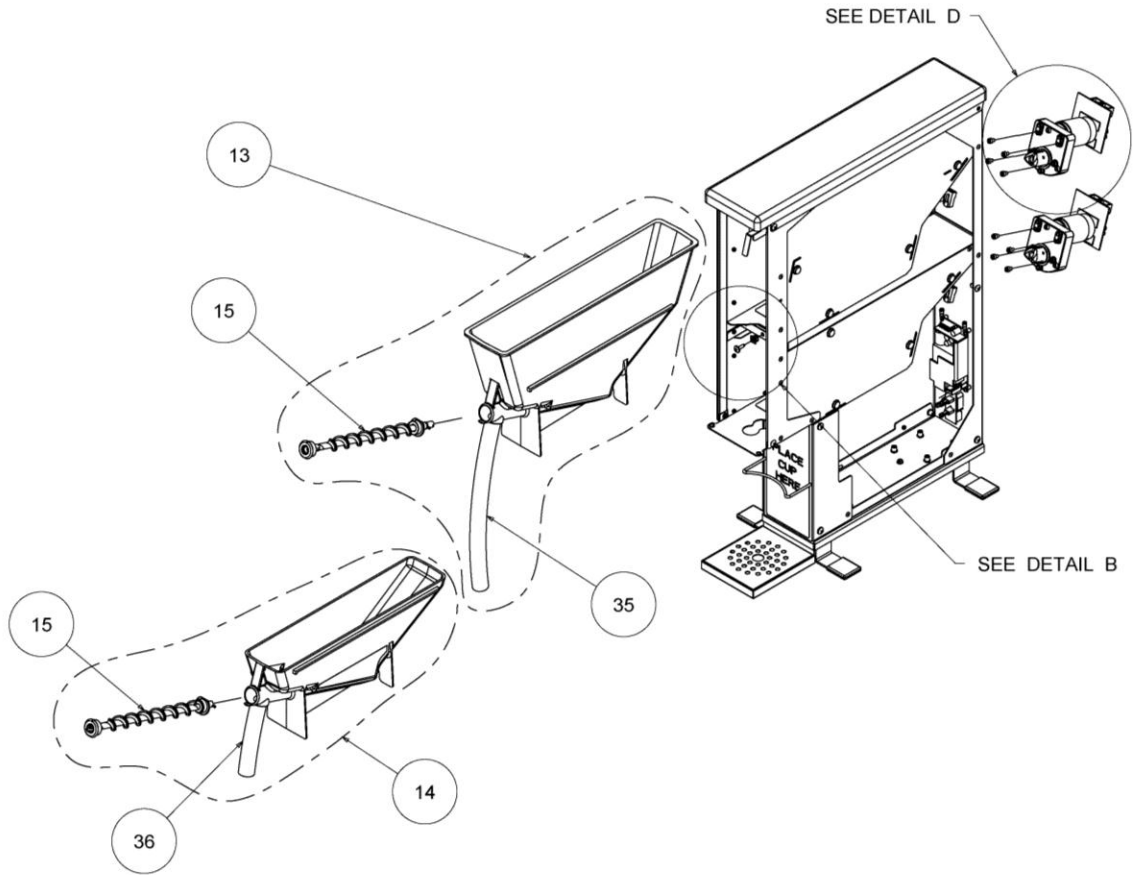

DETAIL B

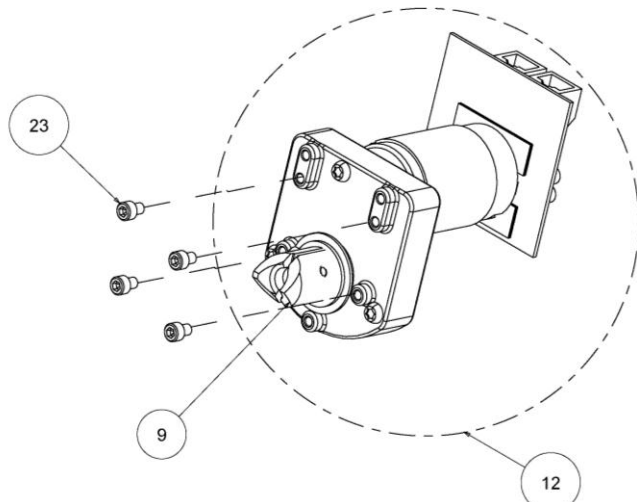

DETAIL D

ITEM	PART NUMBER	DESCRIPTION
1	A-04-101-X *	CATCH TRAY ASSEMBLY. NOTE: ON DISPENSERS WITH FIXED CATCH TRAY BASE USE CATCH TRAY ASS'Y P/N: A-99-082
2	A-09-079-X *	DOOR – COMPLETE ASSEMBLY. NOTE: ON S/N'S LOWER THAN: XXXX-000185 USE PART NUMBER A-09-069-X *
3	A-10-016X *	GROUND WIRE (INTERNAL P/S VERSION ONLY)
4	A-10-020 *	POWER CABLE ASSEMBLY (INTERNAL P/S VERSION ONLY – S/N: XXXX-003875 AND LATER)
5	A-10-024-4	CABLE - MOTOR TO MOTOR / MOTOR TO CONNECTOR PCB
6	A-10-060	DOOR CABLE ASSEMBLY
7	A-10-079-1 *	CABLE ASSEMBLY (INTERNAL P/S VERSION ONLY – S/N: XXXX-003875 AND LATER)
8	A-31-014-076-X *	SOFTWARE (PROVIDED ON FOB)
9	A-31-025	MOTOR COUPLER ASSEMBLY
10	A-31-026 *	POWER SUPPLY CONNECTOR BOARD (FOR EXT. P/S ONLY– S/N: XXXX-003874 AND EARLIER)
11	A-31-027 *	SUB-COVER (NON-FILL-IN-PLACE VERSION ONLY)
12	A-99-068	MOTOR ASSEMBLY
13	A-99-069-1	LARGE/UPPER HOPPER ASSEMBLY
14	A-99-069-2	SMALL/LOWER HOPPER ASSEMBLY
15	A-99-090	AUGER ASSEMBLY
16	A-99-091-X *	FOOT ASSEMBLY
17	E-13-116	POWER CORD (2m/6FT - STANDARD) NOTE: ALTERNATE 3M/10FT CABLE AVAILABLE: P/N: E-13-014
18	E-13-157 *	POWER ENTRY MODULE (INTERNAL P/S VERSION ONLY – S/N: XXXX-003875 AND LATER)
19	E-18-002 *	POWER SUPPLY (INTERNAL P/S VERSION ONLY – S/N: XXXX-003875 AND LATER)
20	A-05-005 *	EXTERNAL POWER SUPPLY (INCLUDES PWER CORD - EXTERNAL P/S VERSION ONLY – S/N: XXXX-003874 AND EARLIER)
21	F-02-007-1	DOOR TOP HINGE SCREW (SHOULDER BOLT)
22		#8 X 5/8" TYPE AB, STAINLESS SCREW
23	F-05-011-8N	MOTOR ATTACHMENT SCREW
24		8-32 X 1/4" PHILLIPS, TRUSS HEAD, MACHINE SCREW
25		4-40 X 1/4" PHILLIPS TRUSS HEAD MACHINE SCREW
26		8-32 X 3/8" BUTTON HEAD, PHILLIPS MACHINE SCREW, SS
27		8-32 X 1/2" PAN HEAD MS, W/ EXTERNAL TOOTH WASHER
28	F-07-007	DOOR HINGE LOWER PIVOT
29	F-09-001	#8 PLASTIC ANCHOR NUT
30	F-14-037-1	DOOR HINGE BUSHING
31	F-16-009-1	DOOR WIRE CLIP
32	M-01-271	SIDE PANEL (RHS). NOTE: ON S/N: LOWER THAN XXXX-000185 USE P/N: M-01-218
33	M-01-273	SIDE PANEL (LHS). NOTE: ON S/N: LOWER THAN XXXX -000185 USE P/N: M-01-229
34	M-02-273-1 *	SUB-COVER (FILL-IN-PLACE VERSION ONLY)
35	M-05-072	DISPENSE TUBE – LARGE/UPPER HOPPER
36	M-05-073	DISPENSE TUBE – SMALL/LOWER HOPPER
37	P-03-003 *	TOP COVER
38	P-03-005 *	TRANSITION PIECE

* Inclusion of part and/or part version is specific to variation of machine. Refer to parts department for inclusion of, and/or applicable variation of, indicated part number.

APPENDIX 2

Wiring Diagram

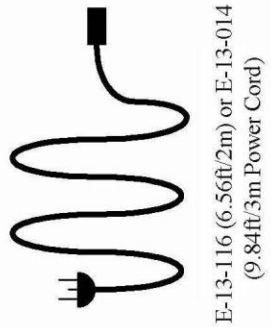
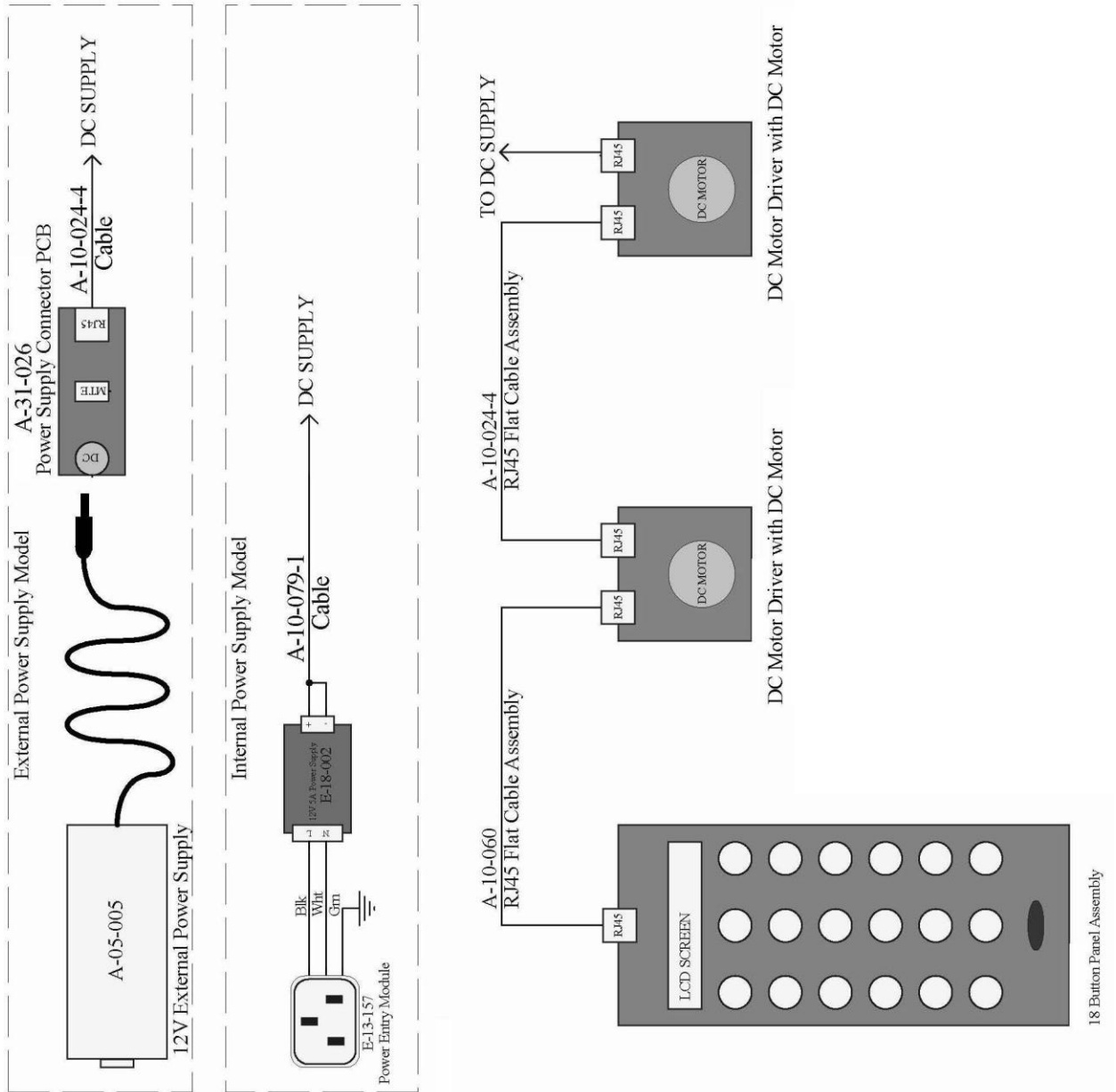



A.C. Dispensing Equipment Inc.
100 Dispensing Way
Lower Sackville
Nova Scotia, Canada B4C 4H2
1-888-777-9990 or 1-902-865-9602
www.sureshotdispensing.com