



Star
Manufacturing
International Inc.

10 Sunnen Dr.
St. Louis, MO 63143

Phone: (314) 781-2777
FAX: (314) 781-2714

Accessory
Instructions

2M-Z6634 Rev. B 5/10/2006

Roller Grill Merchandiser Divider Installation

12/16/11 BBE

These instructions are to add merchandiser dividers & identifiers to your forward or reverse slanted (*Stadium Seating*) Star Roller Grill. The unit does not need disassembling, but does need to have the power turned off and allowed to cool. Once completed, the Dividers should keep your product separate, but not be allowed to actually touch the rollers.

Tools Required: NONE

Contents:

- 2 Short Magnetic Brackets - **Short**
- 2 Long Magnetic Brackets - **Long**
- 2 Divider Mounting Brackets
- 2 or 4 Dividers depending on application
- 6 or 10 Point Of Sale (POS) Magnets

INSTALLATION:



**CAUTION
UNPLUG UNIT BEFORE PROCEEDING.**

1. If necessary, remove the sneeze guard.

STADIUM SEATING, is when the rollers drop from one end of the grill to the other making each set of rollers lower than the next. On some models the highest roller is on the control side.

2. Referring to the illustration, attach the Long Magnetic Brackets to the roller grill in the two interior corners where the rollers are the lowest.
3. Line up the two slots on the Divider Mounting Brackets to the two studs on each of the Long Magnetic Brackets.
4. Repeat the installation for the opposite side where the rollers are the highest.
5. Insert the adjustable Dividers in an appropriate slot on the Divider Mounting Brackets, giving you enough room for your product.
6. Attach your Merchandising Label (not provided) to the P.O.S. Magnets and place them onto the front and rear Divider Mounting Brackets.
7. Reinstall any sneeze guard you may have removed, and turn unit back on.

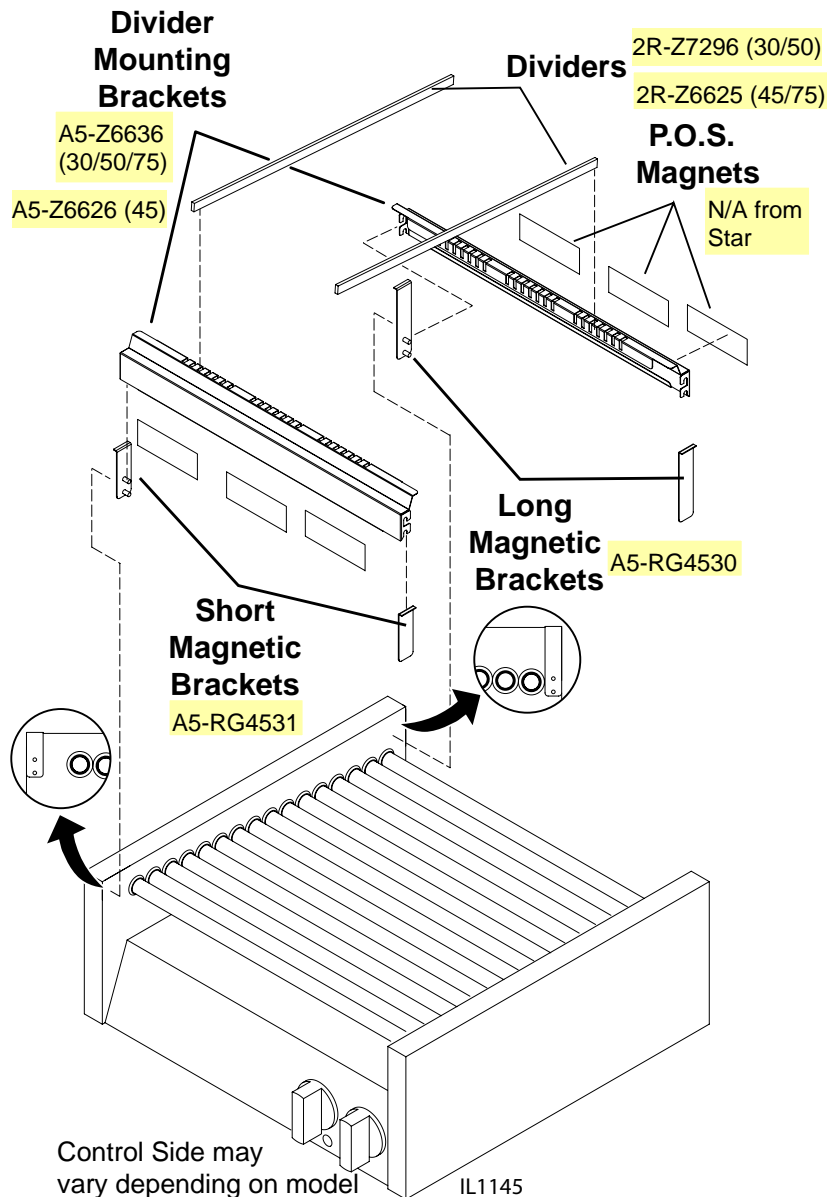

A5-Z6636 = 31-29/32" x 4-13/32" A5-Z6626 = 19-29/32" x 4-13/32"

2R-Z6625 = 26-1/16" x 1/2"

2R-Z7296 = 18-1/2" x 1/2"



STAR MANUFACTURING INTERNATIONAL INC.
#10 SUNNEN DRIVE, ST. LOUIS, MO. 63143, USA

MATERIAL
SEE DRAWING

MODEL NO.
45/75SAR

PART NO.
A5-RG4530

FINISH

TITLE
BRACKET LONG

REVISIONS	LTR	DATE	DESCRIPTION OF CHANGE	DR

DR. CG CK. DATE 1/6/04

TOLERANCES UNLESS OTHERWISE NOTED
FRACTIONS ±1/64 DECIMALS ±.005 ANGLES ±1°

THIS DRAWING CONTAINS INFORMATION CONFIDENTIAL TO STAR MFG. INT'L. INC.
NO REPRODUCTION OR DISCLOSURE OF ITS CONTENTS IS PERMITTED.

12/16/11 BBE

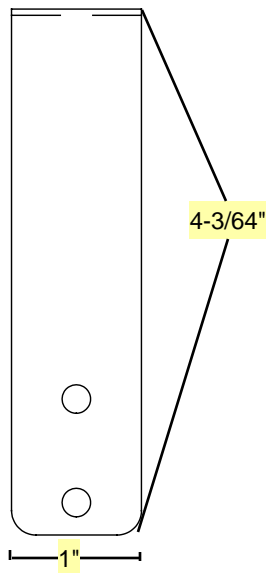

A5-RG4527

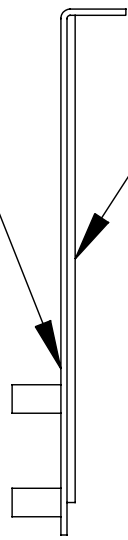

A5-Z7583 PEEL OFF
PAPER AND APPLY
MAGNET TO THIS SIDE



STAR MANUFACTURING INTERNATIONAL INC.
#10 SUNNEN DRIVE, ST. LOUIS, MO. 63143, USA

MATERIAL
SEE DRAWING

MODEL NO.
45/75SAR

PART NO.
A5-RG4531

FINISH

TITLE
BRACKET SHORT

REVISIONS	LTR	DATE	DESCRIPTION OF CHANGE	DR
-	-	-	-	-

DR. CG CK. DATE 1/6/04

TOLERANCES UNLESS OTHERWISE NOTED
FRACTIONS ±1/64 DECIMALS ±.005 ANGLES ±1°

THIS DRAWING CONTAINS INFORMATION CONFIDENTIAL TO STAR MFG. INT'L. INC.
NO REPRODUCTION OR DISCLOSURE OF ITS CONTENTS IS PERMITTED.

12/16/11 BBE

A5-RG4528

A5-Z7584
PEEL OFF PAPER AND
APPLY MAGNET TO
THIS SIDE

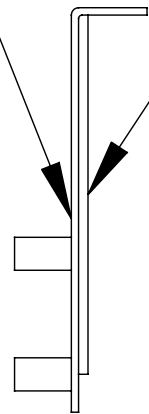
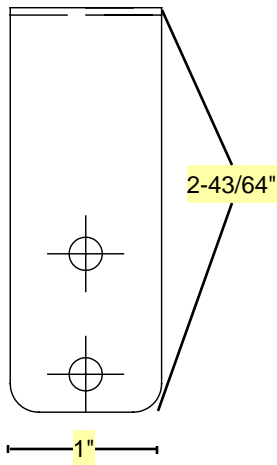



STAR MFG. INTERNATIONAL, INC.
#10 SIMON DRIVE, ST. LOUIS, MO 63143, USA

MATERIAL
22 GA. 430 STAINLESS STEEL

MODEL NO.
75 SAR

PART NO.
A5-Z6636

TITLE
MOUNTING BRACKET - DIVIDER - 5 WIDE

DR. P.M.R. CK. DATE 3/28/03

FINISH
P.P.

REVISIONS
LTR DATE

A 11-1-04

DESCRIPTION OF CHANGE
17/92 WAS 5/8 DR

TOLERANCES UNLESS OTHERWISE NOTED
FRACTIONS ±1/64 DECIMALS ±.005 ANGLES ±1°

THIS DRAWING CONTAINS INFORMATION CONFIDENTIAL TO STAR MFG. INT'L. INC.
NO REPRODUCTION OR DISCLOSURE OF ITS CONTENTS IS PERMITTED.

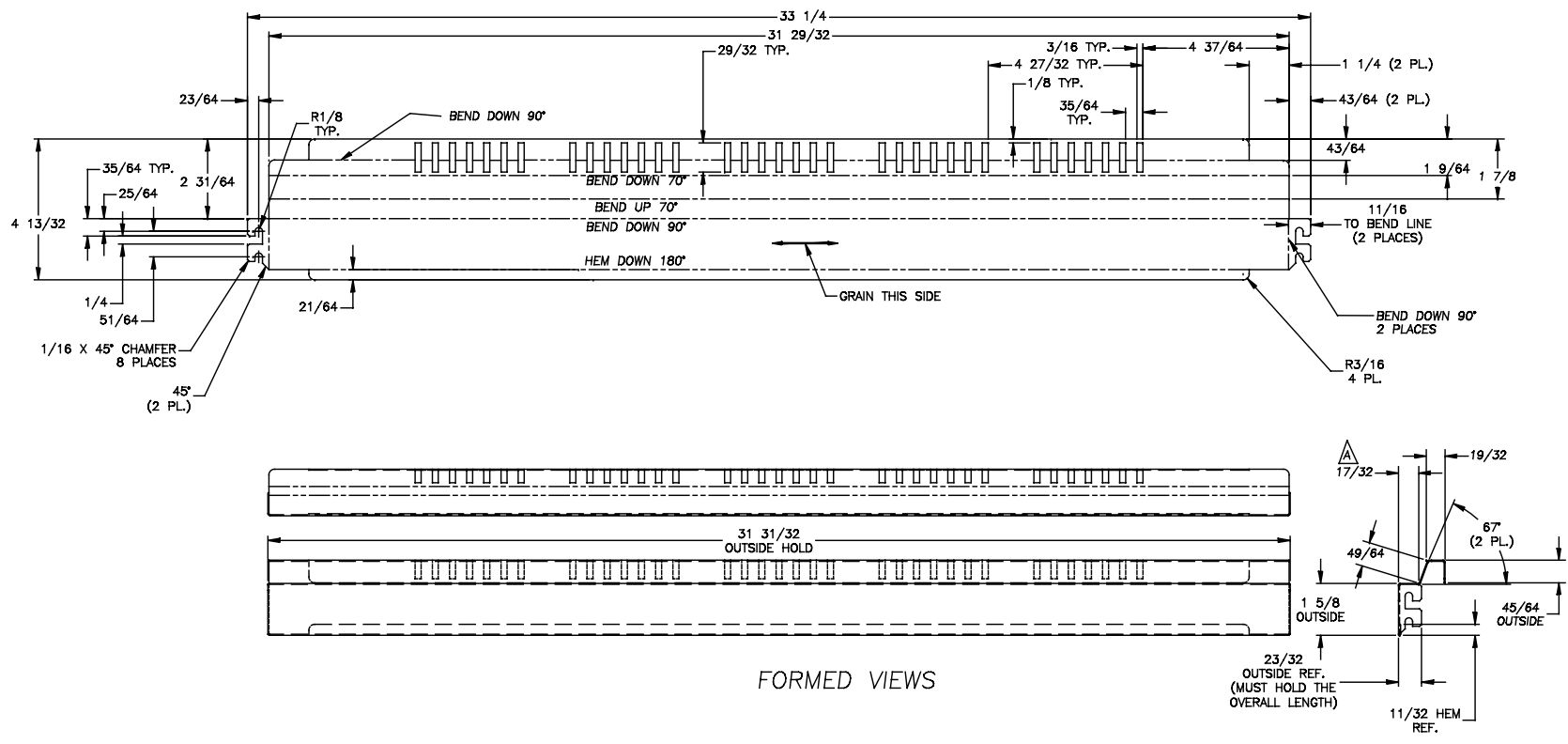

FORMED VIEWS



STAR MANUFACTURING INTERNATIONAL INC.
#10 SUNNEN DRIVE, ST. LOUIS, MO. 63143, USA

MATERIAL
10 GA. X 1/2 300 SERIES STAINLESS STEEL
RECT. BAR

MODEL NO.
45/75 RG

PART NO.
2R-Z6625

FINISH
SEE NOTE 1

TITLE
DIVIDER - 16 CT. ROLLER GRILLS

DR. PMR CK. DATE 10/28/03

REVISIONS	LTR	DATE	DESCRIPTION OF CHANGE	DR
A		4/3/03	26 11/16 WAS 27 5/8.	PR
B		3/29/06 ECO# 4554	26 1/16 WAS 26 7/16.	CG

TOLERANCES UNLESS OTHERWISE NOTED
FRACTIONS ±1/64 DECIMALS ±.005 ANGLES ±1°

THIS DRAWING CONTAINS INFORMATION CONFIDENTIAL TO STAR MFG. INT'L. INC.
NO REPRODUCTION OR DISCLOSURE OF ITS CONTENTS IS PERMITTED.

NOTE(S):

- FINISH SHALL BE CONSISTENT OR SHINEY.
ACCEPTABLE FINISHES:
VIBRATORY FINISH,
NO. 3 OR NO. 4 FINISH ON BOTH SIDES,
OR FINISH APPROVED BY STAR ENGINEERING.

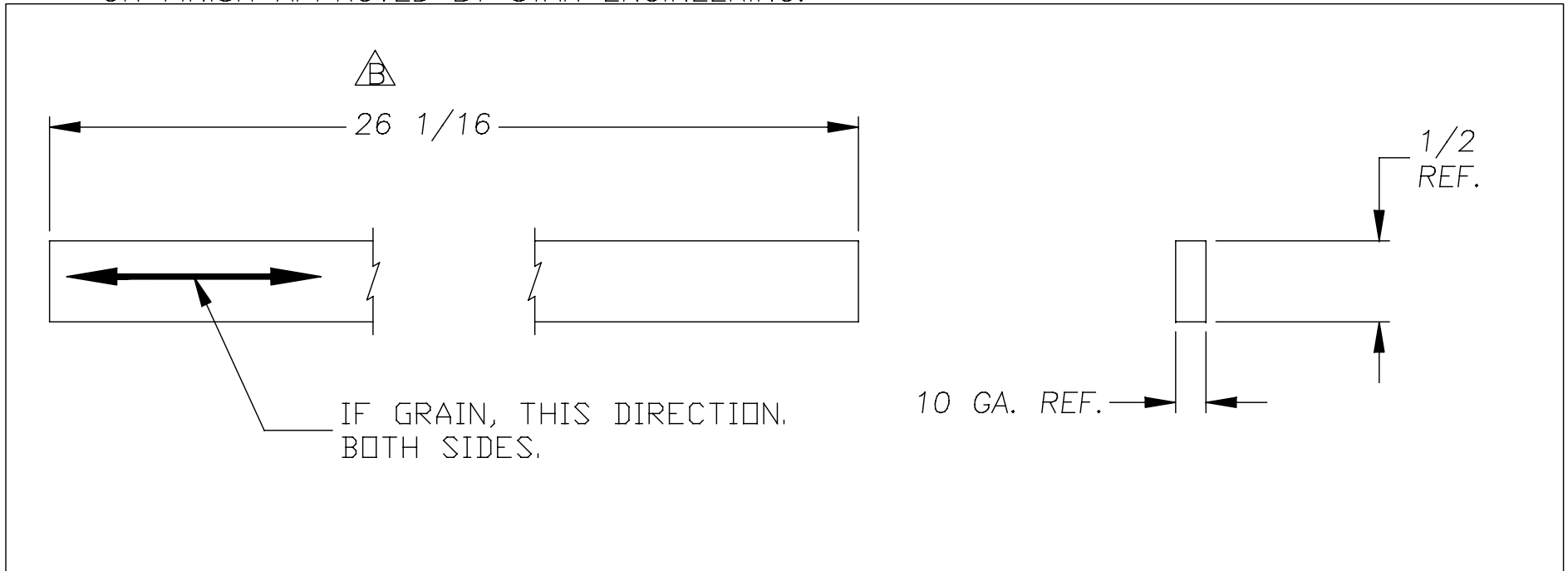



STAR MFG. INTERNATIONAL, INC.
#10 SIMMONS DRIVE, ST. LOUIS, MO 63143, USA

MATERIAL
22 GA. 430 STAINLESS STEEL

MODEL NO.
75 SAR

PART NO.
A5-Z6626

DR. P.M.R. CK. DATE 3/28/03

FINISH P.P.

TITLE MOUNTING BRACKET - DIVIDER - 3 WIDE

TOLERANCES UNLESS OTHERWISE NOTED
FRACTIONS ±1/64 DECIMALS ±.005 ANGLES ±1°

THIS DRAWING CONTAINS INFORMATION CONFIDENTIAL TO STAR MFG. INT'L. INC.
NO REPRODUCTION OR DISCLOSURE OF ITS CONTENTS IS PERMITTED.

REVISIONS LTR DATE DESCRIPTION OF CHANGE DR

KR

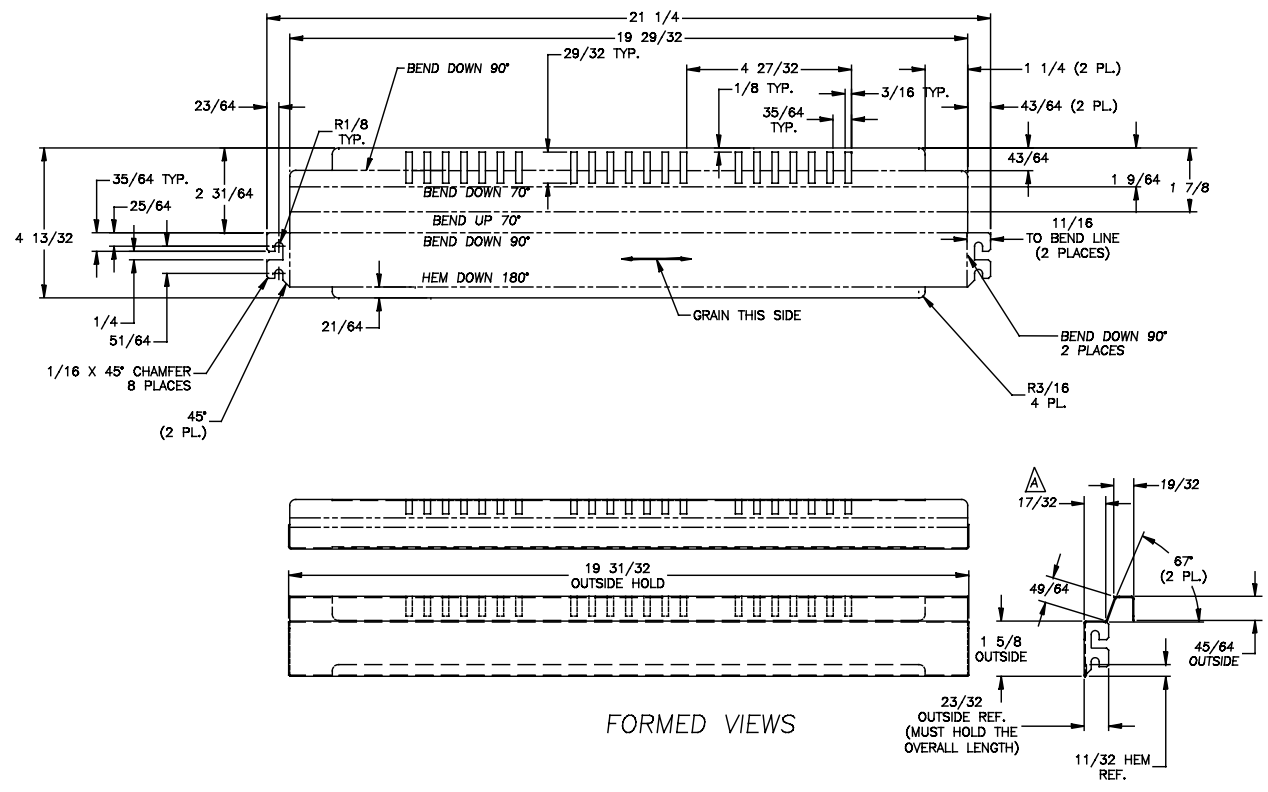

FORMED VIEWS



STAR MANUFACTURING INTERNATIONAL INC.
#10 SUNNEN DRIVE, ST. LOUIS, MO. 63143, USA

MATERIAL
10 GA. X 1/2 300 SERIES STAINLESS STEEL
RECT. BAR

MODEL NO.
30/50 RG

PART NO.
2R-Z7296

FINISH
SEE NOTE 1

TITLE
DIVIDER - 11 CT. ROLLER GRILL

DR. PMR CK. DATE 10/28/03

REVISIONS	LTR	DATE	DESCRIPTION OF CHANGE	DR

TOLERANCES UNLESS OTHERWISE NOTED
FRACTIONS ±1/64 DECIMALS ±.005 ANGLES ±1°

THIS DRAWING CONTAINS INFORMATION CONFIDENTIAL TO STAR MFG. INT'L. INC.
NO REPRODUCTION OR DISCLOSURE OF ITS CONTENTS IS PERMITTED.

NOTE(S):

- FINISH SHALL BE CONSISTENT OR SHINEY.
ACCEPTABLE FINISHES:
VIBRATORY FINISH,
NO. 3 OR NO. 4 FINISH ON BOTH SIDES,
OR FINISH APPROVED BY STAR ENGINEERING.

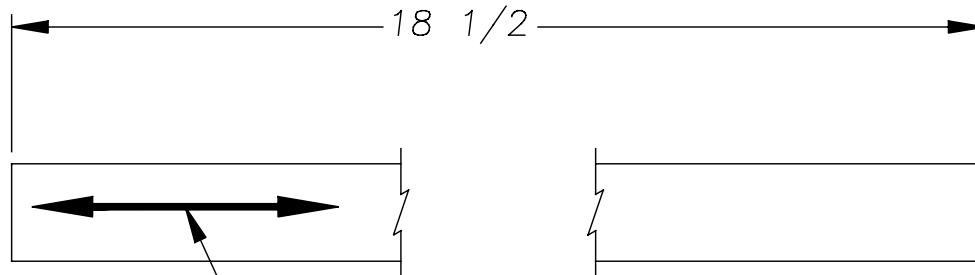

IF GRAIN, THIS DIRECTION.
BOTH SIDES.

