



**Star  
Manufacturing  
International Inc.**

10 Sunnen Drive  
St. Louis, MO 63143

Phone: (314) 781-2777  
Fax: (314) 781-3636

**Installation  
and  
Operating  
Instructions**

2M-Z1423 Rev. E 2/19/04

# DEEP FAT FRYER MODEL 30IHLSMA



## SAFETY SYMBOL



This symbol is intended to alert the user to the presence of important operating and maintenance instructions in the manual accompanying the appliance.

---

## RETAIN THIS MANUAL FOR FUTURE REFERENCE

### NOTICE

Using any part other than genuine Star factory supplied parts relieves the manufacturer of all liability.

### NOTICE

Star reserves the right to change specifications and product design without notice. Such revisions do not entitle the buyer to corresponding changes, improvements, additions or replacements for previously purchased equipment.

## MAINTENANCE AND REPAIRS

Contact your local authorized service agent for service or required maintenance. Refer to the authorized service center listing provided with the unit. The Star Service Help Desk (1-800-807-9054) is available during normal business hours to answer any questions that may arise. Please have your model number and serial number for faster service.

## GENERAL INSTALLATION DATA



### CAUTION

This equipment is designed and sold for commercial use only by personnel trained and experienced in its operation and is not sold for consumer use in and around the home nor for use directly by the general public in food service locations. For equipment to be used by the general public, please contact the factory.

**WARNING:** Improper installation, adjustment, alteration, service or maintenance can cause property damage, injury or death. Read the installation, operating and maintenance instructions thoroughly before installing or servicing the equipment.

This fryer is equipped for the voltage and wattage indicated on the nameplate mounted on the underside of the front edge. It is designed for use on alternating current (AC) only. It is intended for use by properly trained personnel only.



### CAUTION

### DO NOT CONNECT TO DIRECT CURRENT (DC)

The installation of the appliance should conform to:

NATIONAL ELECTRIC CODE AND ALL LOCAL ELECTRIC CODES AND ORDINANCES AND THE LOCAL ELECTRIC COMPANY RULES AND REGULATIONS

Proper connections and power supply are essential for efficient performance. Connect six foot lead in cord to a suitable grounded outlet of the correct voltage. Be sure the switch is in the off position. The receptacle should match the plug (NEMA configuration of receptacle is: 6-30R). Four legs are provided and should be installed for ease of cleaning. Level unit by adjusting the (4) feet which have an adjustment of 1-3/8" (35 mm) for accurate leveling and perfect line-up with other units.

### POWER SUPPLY

The Model 30IHLSMA is wired at the factory for operation on a single phase power supply 208/240V, 60 Hz.



### CAUTION

### DO NOT INSTALL WITHOUT FEET.

### OPERATING INSTRUCTIONS

#### CLEAN KETTLE BEFORE USING

Take out baskets, push down and hold element catch, located on left side of element housing. Lift up on element lift handle until elements lock in a vertical position, and remove kettle. The kettle can be cleaned in a sink like any other pot or container.

#### ADDING FAT

Replace kettle and swing the element down by holding element lift handle and pushing release catch down and holding it there. Lower element. Fryer is now ready for use. Add fat. A fat level line on the rear of the kettle will guide you in determining the minimum cold fat level. A higher fat level can be used when frying bulky foods, such as chicken or fish cakes. The fat level should be chosen carefully so that the foaming action of the fat does not spill out of the kettle. If solid shortening is used, pack carefully around the elements.

## **CONTROLS**

1. **ON/OFF TWO-POLE SWITCH** - Located on the front panel is a two-pole switch which turns power on or off.
2. **THERMOSTAT CONTROL** - Located on the Control Housing, this control allows you to select the desired frying temperature. A signal light indicates when the element is on. When the light goes off, the desired temperature has been reached.
3. **HI-LIMIT THERMOSTAT** - Should fat temperatures reach 450° F (230° C), this control will shut off the power. The light on the control panel will go out. The fat temperature must cool to 400° F (202.4° C) and the manual reset button located on the back panel of the control housing must be pressed to restore operation. Should the hi-limit control activate twice in succession, the primary thermostat should be checked for malfunction by a qualified service technician.

## **FRYING**

After fat has been added, turn the switch on and set the thermostat at 200° F (92.4° C). After the fat has melted, turn the thermostat to the desired setting. Included in this instruction booklet is a frying chart and some helpful hints on fat use. After the selected fat temperature has been reached, the signal light goes out. Slowly lower half filled baskets into the fat. Do not overload baskets as this causes foods to be improperly fried. When moist food is lowered too quickly into hot fat, the fat will foam and spatter excessively.

**NOTE:** Baskets should be allowed to drain after frying cycle. The kettle handles serve as basket hangers.

## **IDLING**

During idle periods turn thermostat control to approximately 200° F (92.4° C). The fast recovery fryers can be brought up to frying temperature in a matter of minutes. Lowering the temperature during idle periods saves energy costs and prolongs fat life. To turn off fryer turn the on/off switch to the "off" position.

## **DRAINING KETTLE**

Turn switch to "OFF". Remove baskets. Raise element to the first stop and allow to drain. Raise the element to the vertical position and siphon the oil out of the kettle. **DO NOT ATTEMPT TO REMOVE THE KETTLE FILLED WITH HOT OIL.** If you do not have a siphon, order one from your dealer or dip the oil out and strain into a container. After oil has been removed, remove the kettle and clean.

## **CLEANING THE EXTERIOR**

The exterior surfaces can be cleaned by regularly wiping with a soft cloth. Any discoloration can be removed with a non-abrasive cleaner.

## **MAINTENANCE AND REPAIRS**

Contact the factory or one of its representatives or a local service company for service or maintenance if required.

# CAUTIONS FOR ALL DEEP FAT FRYERS

NEVER LEAVE AN OPERATING FRYER UNATTENDED

## REMEMBER HOT OIL IS DANGEROUS - RESPECT IT!

1. Hot oil is dangerous - Severe burns can result when hot oil contacts the skin.
2. Locate your fryer in a protected place so it cannot be knocked over or off its support.
3. Keep your floors clean and free of grease so no one slips accidentally and contacts the hot fryer.
4. Hot oil is flammable - Keep open flames away from it and its vapors.
5. Keep areas and filters clean above your fryer - Oil soaked lint or dust can ignite easily and flames will spread rapidly.
6. Install an automatic fire extinguisher over the fryer and in the exhaust duct.
7. Have your equipment checked regularly to insure its safe and proper functioning.
8. If your fryer starts to smoke or boil abnormally, cut off the energy supply immediately and determine the reason for the smoking or boiling before attempting to use it again.
9. Be sure your energy supply is installed properly and in accordance with the local and national codes. There should be a convenient switch or gas valve, readily available, close to the fryer for such a shut-off procedure.
10. See that all of your help understand the hazards of hot fat. Instruct them on the proper action to take if something does not seem to be acting properly.
11. Instruct your personnel on what to do if there is a fat fire. Do not use water on an oil fire! Use only fire extinguishers of the approved type and never direct such extinguishers so as to blow the oil out of the oil container.
12. Never allow water to get in hot fat.  
**It can explode!**

## CARE OF FAT

In three to six months you may spend as much for fat as you paid for your kettle. So fat is an item you want to know all about; how to select it; how to manage it. The more production you can get from each pound of fat, the more profitable your frying operation will be.

To get a high rate of production per pound of fat you have to avoid two things. One is early breakdown and spoilage of the compound so that you have to throw it away before it does enough work to "earn its keep." The other is excessive sponging up of fat by the food being fried.

The main cause of fat breakdown is excessive heat. On the other hand abnormal absorption is caused by frying too long at too low temperatures. One answer to both problems is exact control of heat — so that fat neither smokes up nor soaks up.

Of course, no fat "keeps" forever. Not only heat, but air and moisture, salt particles and crumbs of food work to break it down. But you can slow up fat deterioration by maintaining proper temperatures and by draining your kettle, filtering or straining the fat once or twice a day and by keeping the kettle itself absolutely clean.

A number of commercial devices and materials are available to aid in eliminating fat impurities. There are several excellent models of pressure filters as well as strainer-type filters, which, if used regularly, will prolong life of fat.

However, no purification device will renew broken down or rancid fat or put new life into it. Once you have allowed fat to break down it becomes unsuitable for frying — in fact browning is impossible.

In addition to filtration, you can prolong the usefulness of fat by sweetening it with fresh compound every day - replacing about 15% of the bulk you started with. If you do enough frying so that normal absorption of fat in food amounts to 15% to 20% of the capacity of your kettle every day - then you can call that your turn-over food. It means you can add the recommended 15% of fresh fat without discarding any of the old.

### 10 POINT PROGRAM TO PRESERVE FAT AND PRODUCE THE FINEST FRIED FOODS

1. Choose a fat that does not break down quickly. Hydrogenated shortening, corn, and peanut oils are less likely to break down under high temperatures.
2. Do not fry foods at temperatures above those recommended. The higher the fat temperature, the more rapid the rate of fat deterioration. Above 400°F fats quickly deteriorate.
3. During short intervals between frying, turn the heat down. Do not keep heat on for long periods between batches.
4. Keep fat clean. Strain or filter daily or at end of each shift. Add at least 15% fresh fat to your kettle daily.
5. At least once a day, cool a small amount of fat and taste it to see if it has picked up foreign flavors.
6. Discard fat that tends to bubble excessively before food is added.
7. Do not overload baskets-pieces should not touch when frying. Shake baskets to prevent food from sticking together. Fry similar sizes together.
8. Never salt foods directly over fat, salt in fat reduces its life.
9. Raw, wet foods, such as potatoes and oysters, should be drained or wiped dry before frying to extend the life of the frying fat. Have foods to be fried at room temperature.
10. Keep fat temperatures below smoking point to minimize frying odors.

## HANDY FRYING CHART

FOOD	COATING	PROCEDURE	TEMP	TIME IN MINUTES
<b>POTATOES</b>				
Standard French Fries		Cut in uniform pieces 1/2" square the long way	350	5-7
Blanch Only			350	3-1/2
Brown Only			350	3-1/2
Long Branch		Cut in uniform pieces 3/4" square the long way	350	7-10
Julienne (shoe string)		Cut in uniform pieces 1/8" to 1/4" square the long way	350	3-6
Chips		Soak in cold running water until water does not run milky	350	2-3
<b>CHICKEN</b>				
Large Pieces	Batter or	Some prefer rolling in	325	9-11
Small Pieces	Breading	seasoned flour, dipping in egg wash, and frying	340	7-10
Pre-cooked			350	3-4
<b>FISH</b>				
Fillets (Large)	Breading	Select fillets of uniform size, skin out and dry.	350	4
Fillets (Small)	or Batter		350	3
Oysters	Breading or Batter	Use Oyster liquor in batter or breading	350	5
Clams	Batter		350	1
Scallops	Breading		350	4
Shrimp	Batter	Some prefer soaking 1/2 hour in cold seasoned milk	350	3
Smelts	Breading	Cut spinal cord several places to prevent curling	350	4
<b>MEATS</b>				
Chicken Fried Steak	Breading	Sever all connecting membranes at one inch intervals to prevent curling	360	3-4
Cutlets	Breading		350	3-4
Chops	Breading		340	3-4
Meat Balls	Breading or rolled in flour		340	4-6
Brains	Breading		340	3-5
<b>VEGETABLES</b>				
Asparagus	Batter or crumbs	Pre-cook in salted water	350	3
Cauliflower	Batter or crumbs	Pre-cook and separate flowers	350	3
Egg Plant	Crumb Breading	Peel, cut cross-wise into 1/4" slices	350	3
Onions	Light batter	Slice thin, soak in milk for two hours	350	3
<b>FRITTERS</b>				
Fruit (bananas, pineapples, apricots, berries)		Serve with fruit juice	350	3-5
Corn	Batter	Serve with syrup or jelly	350	3-5
Vegetable (peas, green beans)		Serve with tomato cheese sauce	350	5-8
<b>MISCELLANEOUS</b>				
Croquettes	Breading		360	3
Chinese Noodles			375	1-2
French Toast			375	1
<b>DOUGHNUTS</b>				
Cake			375	1-1/2 - 2
Yeast, raised			375	1



STAR MANUFACTURING INTERNATIONAL INC.  
#10 SUNNEN DRIVE, ST. LOUIS, MO. 63143, USA

MATERIAL

MODEL NO.

301HLSM

PART NO.

SK1724

FINISH

TITLE

WIRING DIAGRAM

DR. T.L.

CK. M.P.

DATE 08-31-99

REVISIONS

LTR

DATE

DESCRIPTION OF CHANGE

DR

TOLERANCES UNLESS OTHERWISE NOTED  
FRACTIONS ± 1/64 DECIMALS ± .005

THIS DRAWING CONTAINS INFORMATION CONFIDENTIAL TO STAR MFG. INT'L. INC.  
NO REPRODUCTION OR DISCLOSURE OF ITS CONTENTS IS PERMITTED.

REVISIONS	LTR	DATE	DESCRIPTION OF CHANGE	DR
-	-	-	-	-

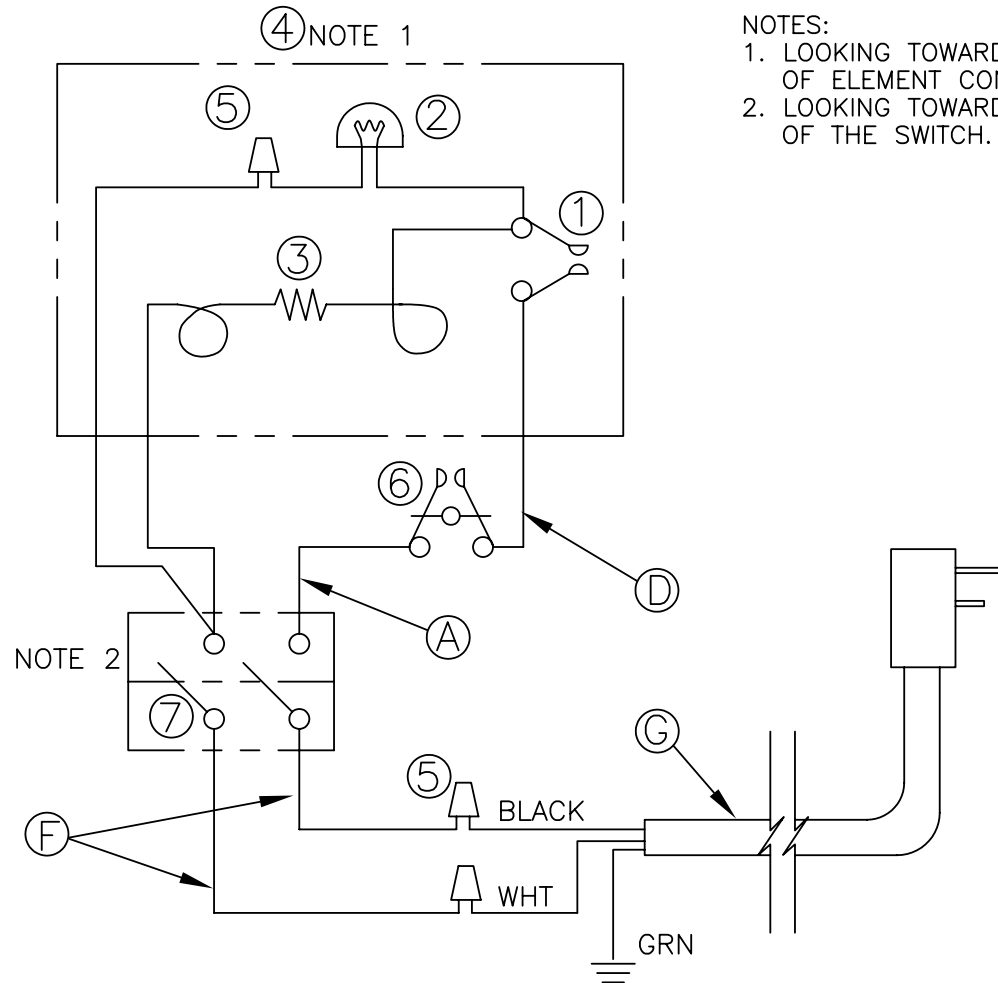

NOTES:

1. LOOKING TOWARDS REAR OF ELEMENT CONTROL ASSEMBLY.
2. LOOKING TOWARDS REAR OF THE SWITCH.

- ① THERMOSTAT
- ② PILOT LIGHT
- ③ HEATING ELEMENT
- ④ ELEMENT HOUSING ASSEMBLY
- ⑤ WIRE NUT
- ⑥ HIGH LIMIT THERMOSTAT
- ⑦ ON-OFF SWITCH (2 POLE)

NOTE: ALL POWER WIRES ARE #12 GAUGE

RATED WATTAGE	SINGLE PHASE	NOMINAL AMPS
4130	208V	19.9
5500	240V	22.9

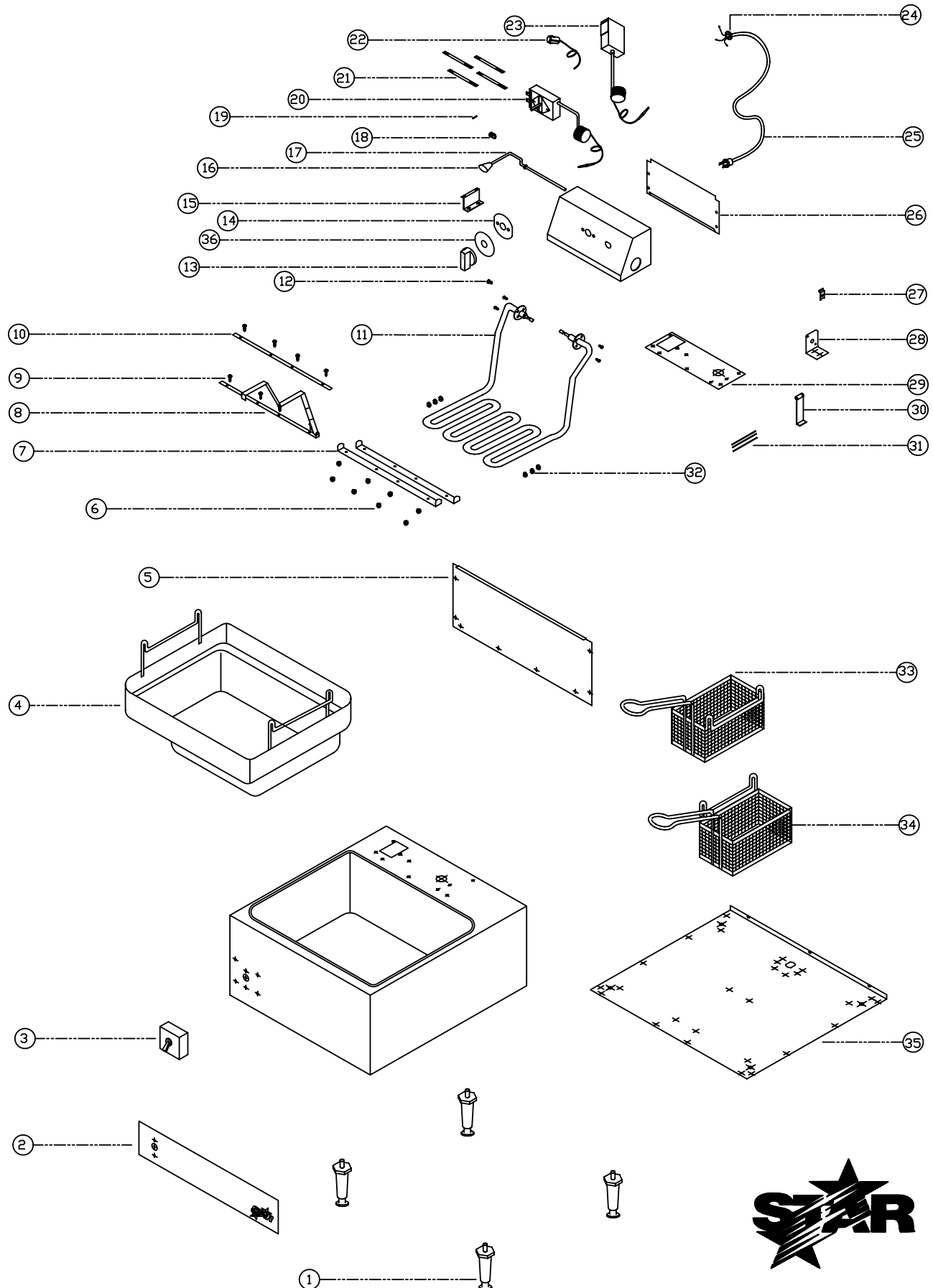

SOME ITEMS ARE INCLUDED FOR ILLUSTRATIVE PURPOSES ONLY AND IN CERTAIN INSTANCES MAY NOT BE AVAILABLE

STAR MANUFACTURING INTERNATIONAL, INC.

MODEL 301HLSMA

SK1618

REV. A

DATE: 01-06-03

DR: SDO



# PARTS LIST

EFFECTIVE 2/19/04 Rev. E

MODEL 30IHLSMA Star-Max Electric Counter Fryer

Key Number	Part Number	Number Per Unit	Description
1	<a href="#">2R-Y5092</a>	4	BLACK PLASTIC LEGS
2	<a href="#">2M-Z6222</a>	1	FACEPLATE (For the Superior Model order part <a href="#">2M-Z6377</a> )
3	<a href="#">2E-Y5166</a>	1	CIRCUIT BREAKER
4	<a href="#">2D-301007</a>	1	KETTLE ASSEMBLY
5	<a href="#">E3-Y7254</a>	1	PANEL-BACK
6	<a href="#">2C-2555</a>	8	NUT-ACORN
7	<a href="#">E3-Y5940</a>	2	LOWER ELEMENT CLAMP
8	<a href="#">E3-301043</a>	1	HANDLE-CLAMP ASSEMBLY
9	<a href="#">2C-H1578</a>	8	SCREW-8-32X1
10	<a href="#">E3-9280</a>	1	CLAMP-ELEMENT
11	<a href="#">2N-Z2920</a>	1	ELEMENT 5500 WATT
12	<a href="#">E3-9288</a>	2	BUSHING-SPLIT
13	<a href="#">2R-Z1299</a>	1	KNOB-THERM. (For the Superior Model order part <a href="#">2R-Z6379</a> )
14	<a href="#">E1-Z1390</a>	1	SWITCH GUARD
15	<a href="#">E3-Y7359</a>	1	BRACKET-THERMO
16	<a href="#">2R-9572</a>	1	KNOB-HARRY DAVIE
17	<a href="#">2A-301005</a>	1	RELEASE ROD ASSEMBLY
18	<a href="#">2P-9274</a>	1	SPRING-RELEASE
19	<a href="#">2A-Y1105</a>	2	PIN ROLL
20	<a href="#">2T-Z7268</a>	1	THERMOSTAT
21	<a href="#">E1-7363</a>	4	CLAMP-THERMOSTAT
22	<a href="#">E3-301059</a>	1	PILOT-LIGHT ASSEMBLY
23	<a href="#">2T-Z3209</a>	1	THERMOSTAT-SAFETY
24	<a href="#">2K-Y6764</a>	1	BUSHING-STRAIN
25	<a href="#">E3-301044</a>	1	CORD-ASSEMBLY
26	<a href="#">E3-9262</a>	1	BACK-ELEMENT HOUSING
27	<a href="#">E3-Y1621</a>	1	CLIP-GROUND
28	<a href="#">E3-7674</a>	2	ANGLE-CAPILLARY
29	<a href="#">2I-9277</a>	1	GASKET
30	<a href="#">E3-9276</a>	1	ARM-PAWL
31	<a href="#">2P-Y3453</a>	4	WIRE-SPACER
32	<a href="#">2P-5737</a>	6	CLIP-CAPILLARY
33	<a href="#">2B-301042</a>	1	BASKET, RIGHT
34	<a href="#">2B-301041</a>	1	BASKET, LEFT
35	<a href="#">E3-Y7255</a>	1	BOTTOM
36	<a href="#">2M-Z7219</a>	1	SIGN-STICKER

**IMPORTANT: WHEN ORDERING, SPECIFY VOLTAGE OR TYPE GAS DESIRED  
INCLUDE MODEL AND SERIAL NUMBER**

PAGE 1  
OF 1

Some items are included for illustrative purposes only and in certain instances may not be available.



**Star Manufacturing International, Inc.**