



**Star
Manufacturing
International Inc.**

10 Sunnen Drive
St. Louis, MO 63143

Phone: (314) 781-2777
FAX: (314) 781-3636

**Installation
and
Operating
Instructions**

2M-Y7198 Rev. F 6/28/00

**STAR-MAX
GAS CHARBROILER
MODELS
6015CB, 6024CB, 6036CB,
6115RCB, 6124RCB, and 6136RCB**

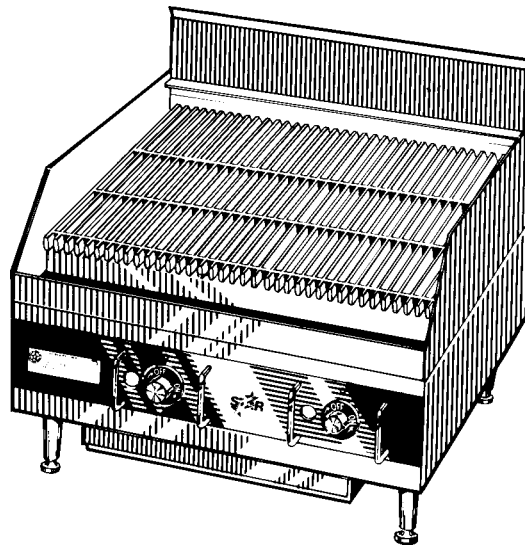

Model 6024CB



GENERAL INSTALLATION DATA



CAUTION

This equipment is designed and sold for commercial use only by personnel trained and experienced in its operation and is not sold for consumer use in and around the home nor for use directly by the general public in food service locations. For equipment to be used by the general public, please contact the factory.

The Star-Max series gas charbroiler is equipped for the type of gas indicated on the nameplate mounted on the front panel. All units are shipped from the factory for use with natural gas. The unit can easily be converted for use with propane gas: see propane gas.

-IMPORTANT-

INSTALLATION: INSTALL IN NON-COMBUSTIBLE LOCATIONS ONLY! Clearance from non-combustible construction must be 6" from back and sides.

The installation of the Appliance must conform to the NATIONAL FUEL GAS CODE "ANSI Z223.1 - LATEST EDITION" AND ALL LOCAL GAS COMPANY RULES AND REGULATIONS.

IN CANADA INSTALLATION SHALL BE IN ACCORDANCE WITH THE CURRENT CAN/CGA-B149.1 NATURAL GAS INSTALLATION CODE OR CAN/CGA-B149.2 PROPANE INSTALLATION CODE AND LOCAL CODES WHERE APPLICABLE.

WARNING: Improper installation, adjustment, alteration, service or maintenance can cause property damage, injury or death. Read the installation, operating and maintenance instructions thoroughly before installing or servicing the equipment.

FOR YOUR SAFETY

DO NOT STORE OR USE GASOLINE OR OTHER FLAMMABLE VAPORS AND LIQUIDS IN THE VICINITY OF THIS OR ANY OTHER APPLIANCE. KEEP THE APPLIANCE AREA CLEAR AND FREE FROM COMBUSTIBLES.

This appliance, its pressure regulator and its individual shutoff valve must be disconnected from the gas supply piping system during any pressure testing of that system at test pressures in excess of 1/2 PSIG. This appliance and its pressure regulator must be isolated from the gas supply piping system by closing its individual manual shutoff valve during any pressure testing of the gas supply piping system at test pressures equal to or less than 1/2 PSIG. For your protection, we recommend a qualified installing agency install this appliance. They should be familiar with gas installations and your local gas requirements. In any case, your gas company should be called to approve the final installation. In addition, there should be posted, in a prominent location, detailed instructions to be followed in the event the operator smells gas. Obtain the instructions from the local gas supplier.

LEVELING UNIT

This charbroiler is supplied with 4 feet which must be screwed into the body. Level unit by adjusting the (4) feet which have an adjustment of 1-3/4" for accurate and perfect line-up with other units. **CAUTION: DO NOT INSTALL WITHOUT ATTACHING FEET - DO NOT REMOVE FEET.**

GAS INPUT TO CHARBROILER:

Models 6015CB and 6115RCB 25,000 BTU/HR
Models 6024CB and 6124RCB 50,000 BTU/HR
25,000 BTU/HR/BURNER
Models 6036CB and 6136RCB 75,000 BTU/HR
25,000 BTU/HR/BURNER

GAS PIPING

Gas piping shall be of such size and so installed as to provide a supply of gas sufficient to meet the full gas input of the appliance. If the appliance is to be connected to existing piping, it shall be checked to determine if it has adequate capacity. Joint compound (pipe dope) shall be used sparingly and only on the male threads of the pipe joints. Such compounds shall be resistant to the action of L.P. gases. **WARNING:** Any loose dirt or metal particles which are allowed to enter the gas lines on this appliance will damage the valve and affect its operation. When installing this appliance, all pipe and fittings must be free from all internal loose dirt.

GAS PRESSURE REGULATOR

A convertible pressure regulator is provided with each charbroiler. It should be connected to the inlet pipe at the rear of the unit. The gas supply is then connected to it. It is shipped set for 6" water column manifold pressure for use with natural gas. Allow 6" clearance from back of unit to wall for servicing and installation.

CONNECTING GAS SUPPLY LINE

The gas inlet of the charbroiler is sealed at the factory to prevent entry of dirt. Do not remove this seal until the actual connection is made to the gas supply line.

MANUAL SHUT OFF VALVE

A manual shut off valve should be installed upstream from the manifold and within six feet of the charbroiler.

PROPANE GAS

This charbroiler is equipped with fixed orifice hoods and is shipped from the factory for use with natural gas. To convert to propane gas, install the burner orifice hoods supplied behind the front panel as follows:

1. Remove grill, radiants and burners.
2. Remove the burner orifice hoods and install the orifice hoods supplied.
3. Replace the burners, radiants, and grill.
4. Set manifold pressure to (10) inch water column. A 1/8" pipe plug on the burner manifold can be removed for attaching a pressure gauge.

Remove the slotted, or hex-threaded plug from the pressure regulator. Invert the plug and re-install. The letters "LP" should now be visible on the plug. The regulator is now set for 10" (25.4 cm) water column.

CHECKING FOR GAS LEAKS

Soap and water solution or other material acceptable for the purpose, shall be used in locating gas leakage. Matches, candle flame or other sources of ignition shall not be used for this purpose. Check entire piping system for leaks.

PILOT LIGHTING INSTRUCTIONS

The charbroiler is equipped with standing pilots, and should be lit immediately after the gas is turned on.

1. Turn off main valve to unit and wait 5 minutes to clear gas.
2. Turn off all knobs and pilot valves.
3. Turn on main valve and light all pilots.
4. Turn burner knobs to desired setting.
5. To turn burners off, turn knobs off.

SHUTTING DOWN INSTRUCTIONS

1. Turn the burner valve knobs to the off position to turn burners off.

PILOT LIGHT REGULATION

The pilot lights on this broiler have been turned off at the factory. Adjust pilot light flames as small as possible, but high enough to light burner immediately when burner valve is turned on high.

BURNER OPERATION

To ignite burners, turn burner valve knob to "HI" position. Each burner is controlled by an individual high-low, on-off valve. An infinite number of broiling temperatures may be obtained by turning the burner valve knob to any position between high and low.

BURNER ADJUSTMENT

1. Turn burner valve knob to "HI" position.
2. Slowly decrease openings of air shutters to give a soft blue flame having luminous tips, then slowly increase openings to a point where the yellow tips disappear and a hard blue flame is obtained.

EXHAUST CANOPY

Open hearth broilers inherently create a good deal of heat and smoke and should be installed under an efficient exhaust hood with flame proof filters. A vertical distance of not less than 48" shall be provided between the top of the appliance and filters or any other combustible material.

AIR SUPPLY

Provisions for adequate air supply must be provided.

OPERATING INSTRUCTIONS

LIGHTING

When broiler is first lit, it will smoke until the preservation oils and impurities are burned off.

BROILING

Turn valves on and pre-heat unit on "HI" before attempting to broil. You will have to experiment with the grill settings and the valve settings for your particular meat products. We recommend that you set the grate at the full tilt position to start with. This position allows the grease to run down the grate into the grease tray, reducing flare ups. Check water pans frequently and add a sufficient amount of water when necessary. Hot water vapors rising from the water pans and through the combustion chamber helps reduce flare ups. Exercise care when using your broiler.

TILTING THE GRATE

Raise or lower the grate to the next step by lifting the grate at the back of the charbroiler where the grate rests. Use potholders or gloves to reposition.



CAUTION

CHARBROILERS ARE HOT! NEVER ATTEMPT TO CHANGE THE GRILL POSITION WHILE MEAT PRODUCTS ARE COOKING. FLARE UPS CAN OCCUR UNEXPECTEDLY. TURN OFF CHARBROILER, AND ALLOW THE CHARBROILER TO COOL.

ADJUSTING HEAT PATTERN

It is possible through this arrangement to have a high heat or searing section, while having a low heat finishing or holding section. For the searing operation, set the valves for the section at a position of "HI" or close to it. For holding or finishing, set the valves closer to the "LOW" position on the dial. You select the heat pattern you like, and set the valves accordingly.

CLEANING

Clean regularly. Remove grate section to sink for washing. Brush out carboned particles. Remove and wash water pan. Wipe exterior surfaces with detergent and a cloth. A non-abrasive cleaner can be used on caked areas.

WATER PAN

The water pan is located at the bottom of the unit, and is easily removed from the front of the unit. Water should be added to the water pan and replaced as necessary. The water pan helps prevent flare ups and catches grease.

AIR INTAKES IN BOTTOM

Air for combustion enters from the bottom of the unit. Do not obstruct this area.

MAINTENANCE AND REPAIRS

Contact the factory or one of its representatives or a local service company for service or maintenance if required.

RETAIN THIS MANUAL FOR FUTURE REFERENCE
Part No. 2M-Y7198 Rev. F 6/28/00

THOROUGHLY INSPECT YOUR UNIT ON ARRIVAL

This unit has been tested for proper operation before leaving our plant to insure delivery of your unit in perfect condition. However, there are instances in which the unit may be damaged in transit. In the event you discover any type of damage to your product upon receipt, you must immediately contact the transportation company who delivered the item to you and initiate your claim with same. If this procedure is not followed, it may affect the warranty status of the unit.

LIMITED EQUIPMENT WARRANTY

All workmanship and material in Star products have a one (1) year limited warranty on parts & labor in the United States and Canada. Such warranty is limited to the original purchaser only and shall be effective from the date the equipment is placed in service. Star's obligation under this warranty is limited to the repair of defects without charge, by the factory authorized service agency or one of its sub-agencies. Models that are considered portable (see below) should be taken to the closest Star service agency, transportation prepaid.

- > Star will not assume any responsibility for loss of revenue.
- > On all shipments outside the United States and Canada, see International Warranty.
- * The warranty period for the JetStar series six (6) ounce popcorn machines is two (2) years.
- * The warranty period for the Chrome-Max Griddles is five (5) years on the griddle surface. See detailed warranty provided with unit.
- * The warranty period for Teflon/Dura-Tec coatings is one year under normal use and reasonable care. This warranty does not apply if damage occurs to Teflon/Dura-Tec coatings from improper cleaning, maintenance, use of metallic utensils, or abrasive cleaners. This warranty does not apply to the "non-stick" properties of such materials.
- > This warranty does not apply to "Special Products" but to regular catalog items only. Star's warranty on "Special Products" is six (6) months on parts and ninety (90) days on labor.
- > This warranty does not apply to any item that is disassembled or tampered with for any purpose other than repair by a Star Authorized Service Center or the Service Center's sub-agency.
- > This warranty does not apply if damage occurs from improper installation, misuse, wrong voltage, wrong gas or operated contrary to the Installation and Operating instructions.
- > This warranty is not valid on Conveyor Ovens *unless* a "start-up/check-out" has been performed by a Factory Authorized Technician.

PARTS WARRANTY

Parts that are sold to repair out of warranty equipment are warranted for ninety (90) days. The part only is warranted. Labor to replace the part is chargeable to the customer.

SERVICES NOT COVERED BY WARRANTY

- | | |
|--|---|
| 1. Travel time and mileage rendered beyond the 50 mile radius limit | 10. Voltage conversions |
| 2. Mileage and travel time on portable equipment (<i>see below</i>) | 11. Gas conversions |
| 3. Labor to replace such items that can be replaced easily during a daily cleaning routine, ie; removable kettles on fryers, knobs, grease drawers on griddles, etc. | 12. Pilot light adjustment |
| 4. Installation of equipment | 13. Miscellaneous adjustments |
| 5. Damages due to improper installation | 14. Thermostat calibration and by-pass adjustment |
| 6. Damages from abuse or misuse | 15. Resetting of circuit breakers or safety controls |
| 7. Operated contrary to the Operating and Installation Instructions | 16. Replacement of bulbs |
| 8. Cleaning of equipment | 17. Replacement of fuses |
| 9. Seasoning of griddle plates | 18. Repair of damage created during transit, delivery, & installation OR created by acts of God |

PORTABLE EQUIPMENT

Star will not honor service bills that include travel time and mileage charges for servicing any products considered "Portable" including items listed below. These products should be taken to the Service Agency for repair:

- * The Model 510F Fryer.
 - * The Model 526TO Toaster Oven.
 - * The Model J4R, 4 oz. Popcorn Machine.
 - * The Model CFS Series Food Steamer.
 - * The Model 526WO Warming Oven.
 - * The Model 518CM & 526CM Cheese Melter.
 - * The Model 12MC & 15MC & 18MCP Hot Food Merchandisers.
 - * The Model 12NCPW & 15NCPW Nacho Chip/Popcorn Warmer.
 - * All Hot Dog Equipment **except Roller Grills & Drawer Bun Warmers.**
 - * All Nacho Cheese Warmers **except Model 11WLA Series Nacho Cheese Warmer.**
 - * All Condiment Dispensers **except the Model CSD & HPD Series Dispenser.**
 - * All Specialty Food Warmers **except Model 130R, 500, 11RW Series, and 11WSA Series.**
- ALL:**
- * Pop-Up Toasters
 - * Butter Dispensers
 - * Pretzel Merchandisers
 - * Pastry Display Cabinets
 - * Nacho Chip Merchandisers
 - * Accessories of any kind
 - * Sneeze Guards
 - * Pizza Ovens
 - * Heat Lamps
 - * Hot Cups
 - * Pumps

The foregoing warranty is in lieu of any and all other warranties expressed or implied and constitutes the entire warranty.

FOR ASSISTANCE

Should you need any assistance regarding the Operation or Maintenance of any Star equipment; write, phone, fax or email our Service Department. In all correspondence mention the Model number and the Serial number of your unit, and the voltage or type of gas you are using.

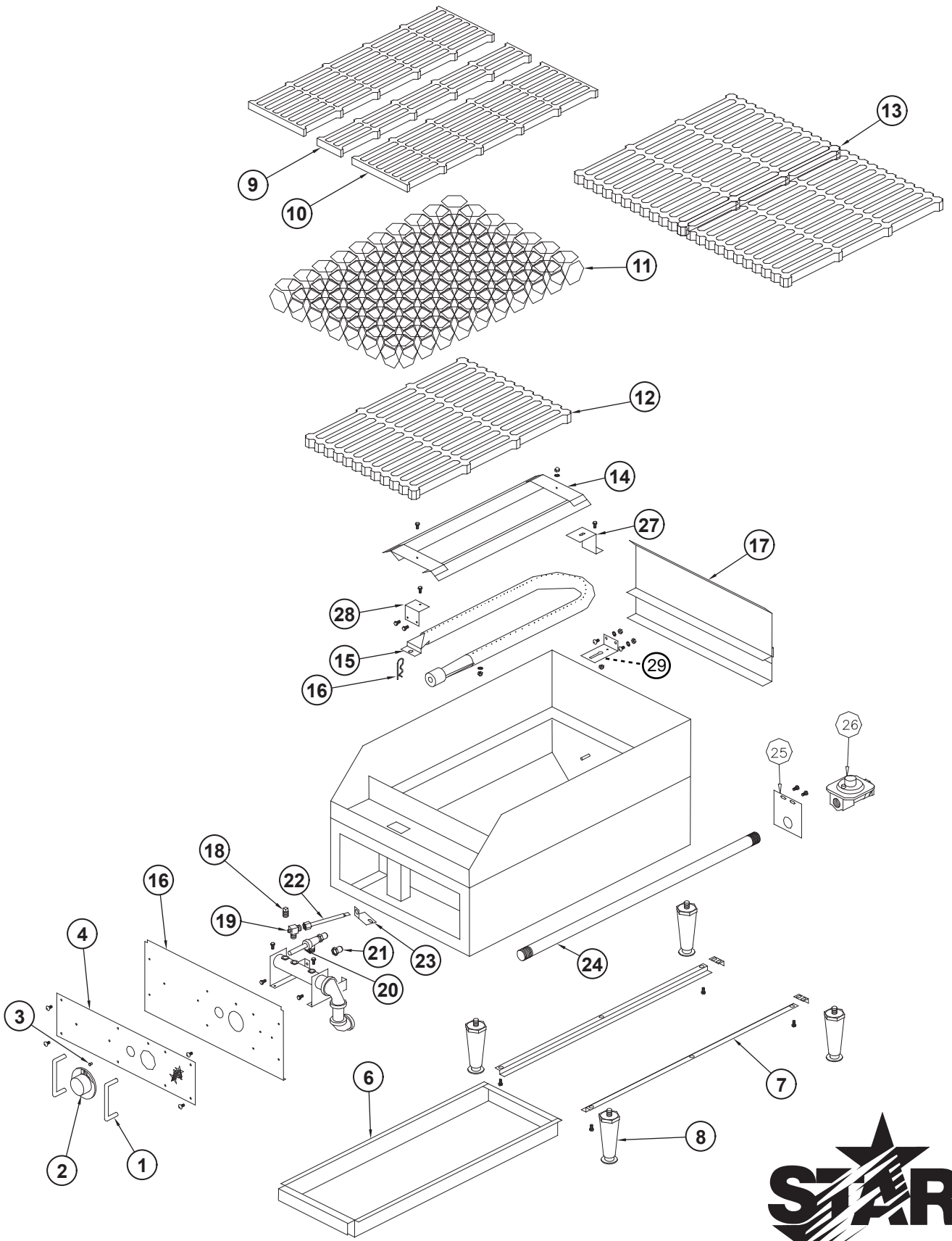

MODEL 6015CB, 6024CB, 6036CB

STAR MANUFACTURING INTERNATIONAL, INC.

SK1271

REV A

8/25/06

PARTS LIST

February 17, 2011, Rev. D

MODEL 6015CB, 6024CB, 6036CB Star-Max Gas Lava Rock Charbroiler-15", 24", 36"

Key Number	Part Number	Number Per Unit	Description and Model Designation
1	2R-8229	2/4/6	SHIELD KNOB 6015CB/6024CB/6036CB
2	2R-9364	1/2/3	KNOB-CONTROL 6015CB/6024CB/6036CB
3	2R-9193	1/2/3	INDICATOR BUTTON 6015CB/6024CB/6036CB
4	2M-Y9495	1	FACEPLATE 6015CB
	2M-Y9479	1	FACEPLATE 6024CB
	2M-Y9480	1	FACEPLATE, LEFT 6036CB
	2M-Y9481	1	FACEPLATE, RIGHT 6036CB
5	G3-Y7152	1	FRONT PANEL 6015CB
	G3-Y7016	1	FRONT PANEL 6024CB
	G3-Y7014	1	FRONT PANEL 6036CB
6	H3-T1026	1	GREASE DRAWER 6015CB
	H3-Y7045	1	GREASE DRAWER 6024CB
	H3-Y7044	1	GREASE DRAWER 6036CB
7	G3-Y7047	2	SLIDE DRAWER
8	2A-Z0314	4	LEG
9	2F-Y8831	1	GRATE 3" 6015CB
10	2F-Y8830	2/4/6	GRATE 6" 6015CB/6024CB/6036CB
11	2F-Y7193	1/2/3	LAVA ROCK 2" 8 LBS. 6015CB/6024CB/6036CB
12	2F-Y7141	1	GRATE LAVA ROCK 15" 6015CB, 6036CB
13	2F-Z3273	2	GRATE LAVA ROCK 10.5" 6024CB, 6036CB
14	H3-624086	1/2/3	BURNER GUARD ASSEMBLY 6015CB/6024CB/6036CB (AS PICTURED)
15	2F-Y7052	1/2/3	BURNER ASSEMBLY (AS PICTURED) 6015CB/6024CB/6036CB (EFFECTIVE 1/92)
16	2A-Y6694	1/2/3	CLIP 6015CB/6024CB/6036CB
17	G3-624038	1	GUARD WELD ASSEMBLY 6015CB
	G3-624037	1	GUARD WELD ASSEMBLY 6024CB
	G3-624039	1	GUARD WELD ASSEMBLY 6036CB
18	2P-1453	1	PLUG-PIPE
19	2V-6671	1/2/3	VALVE-PILOT 6015CB/6024CB/6036CB
20	2V-Y8832	1/2/3	VALVE-BURNER 6015CB/6024CB/6036CB
21	2J-Y8838	1/2/3	HOOD BURNER NAT. #45 6015CB, 6024CB/6036CB
	2J-Y7136	1/2/3	HOOD BURNER LP. #53 6015CB/6024CB/6036CB
22	G3-Y7355	1/2/3	TUBE-PILOT 6015CB/6024CB/6036CB
23	G3-Y7356	1/2/3	PILOT BRACKET 6015CB/6024CB/6036CB
24	2K-Y7123	1	INLET PIPE
25	G3-Y7252	1	INLET PIPE SUPPORT
26	2J-Y7589	1	PRESSURE REGULATOR
27	H3-Y7569	1/2/3	COVER, BURNER BACK
28	H3-Y7570	1/2/3	COVER, BURNER FRONT
NI	H3-Y7095	1/2/3	Bracket Burner

**IMPORTANT: WHEN ORDERING, SPECIFY VOLTAGE OR TYPE GAS DESIRED
INCLUDE MODEL AND SERIAL NUMBER**

PAGE 1
OF 1

Some items are included for illustrative purposes only and in certain instances may not be available.



STAR MANUFACTURING

10 Sunnen Drive, St. Louis, MO 63143 U.S.A.

(800) 807-9054 (314) 781-2777

Parts & Service (800) 807-9054

www.star-mfg.com