



ELECTRIC COUNTER TOP CONVECTION OVEN

CCOHS-3

CCOQS-3

Installation and Operation Instructions

2M-Z11295 Rev. C 2/24/2012

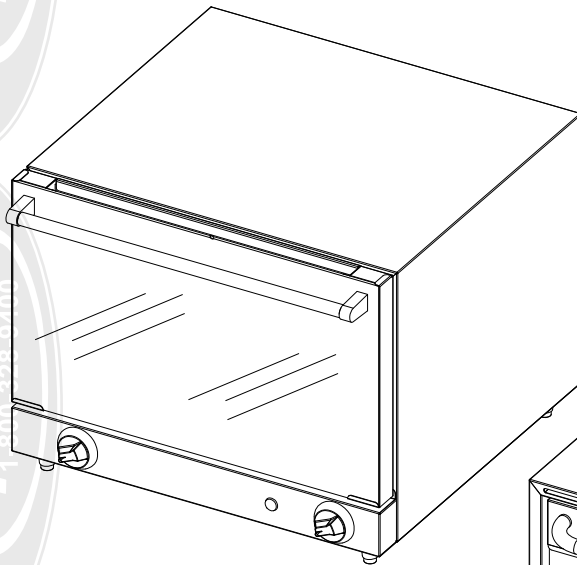

CCOQS-3

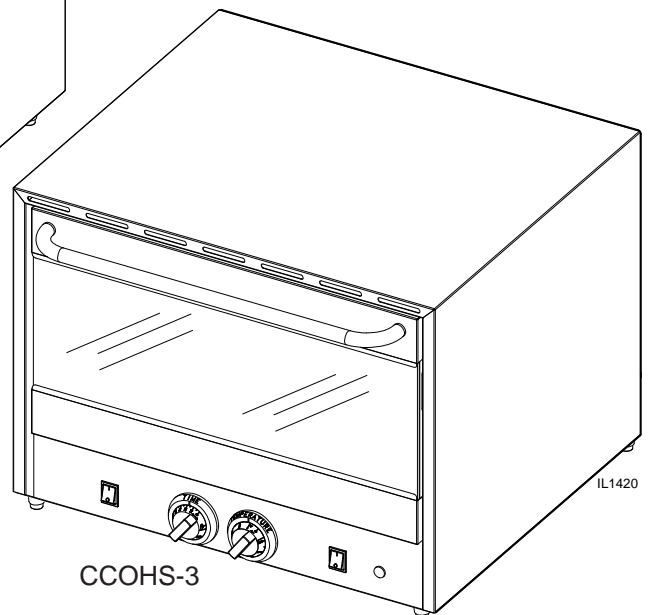

CCOHS-3

IL1420

SAFETY SYMBOL



These symbols are intended to alert the user to the presence of important operating and maintenance instructions in the manual accompanying the appliance.

RETAIN THIS MANUAL FOR FUTURE REFERENCE NOTICE

Using any part other than genuine Star factory supplied parts relieves the manufacturer of all liability.

Star reserves the right to change specifications and product design without notice. Such revisions do not entitle the buyer to corresponding changes, improvements, additions or replacements for previously purchased equipment.

Due to periodic changes in designs, methods, procedures, policies and regulations, the specifications contained in this sheet are subject to change without notice. While Star International Holdings Inc., Company exercises good faith efforts to provide information that is accurate, we are not responsible for errors or omissions in information provided or conclusions reached as a result of using the specifications. By using the information provided, the user assumes all risks in connection with such use.

MAINTENANCE AND REPAIRS

Contact your local authorized service agent for service or required maintenance.

Please record the model number, serial number, voltage and purchase date in the area below and have it ready when you call to ensure a faster service.

Model No. _____
Serial No. _____
Voltage _____
Purchase Date _____

Authorized Service Agent Listing

Reference the listing provided with the unit

or

for an updated listing go to:

Website: www.star-mfg.com
E-mail Service@star-mfg.com

Service Help Desk

Business Hours: 8:00 am to 4:30 p.m. Central Standard Time

Telephone: (314) 678-6303

Fax: (314) 781-2714

E-mail Parts@star-mfg.com
Service@star-mfg.com
Warranty@star-mfg.com

Website: www.star-mfg.com

Mailing Address: Star International Holdings Inc., Company
10 Sunnen Drive
St. Louis, MO 63143
U.S.A



SPECIFICATIONS

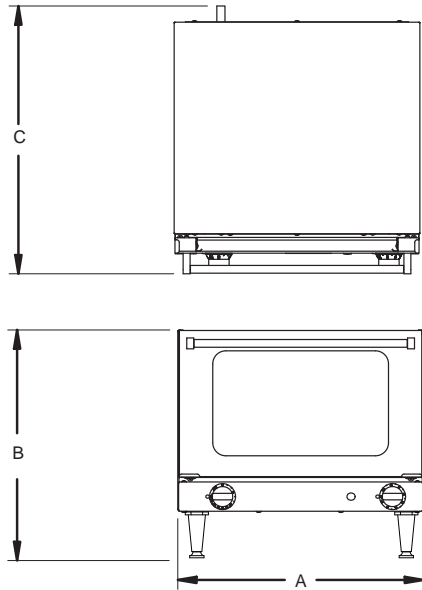

Superior Countertop Convection Ovens are constructed of highly polished stainless steel with high performance heating elements and rear fans, stainless steel door handle, chrome plated wire racks and rack slides. The bake chamber is made of stainless steel or porcelain. The oven door is double pane tempered glass and features a heavy-duty hinge mechanism. Thermostat range is 175°F / 79°C to 500°F / 260°C. Timer range is 0 to 120 minutes. Oven features a heat indicator light and door interlock switch. Oven holds either 3 or 4 standard size baking sheets. Units available in various voltages and is shipped with a NEMA plug installed.

Mode No.	"A" Width Inches/CM	"B" Height Inches/CM	"C" Depth Inches/CM	Approximate Ship Weight
CCOHS-3	24.4in / 62cm	21.5in / 54.6cm	23.4in / 59.4cm	86lbs / 39.1kg
CCOQS-3	19in / 48.3cm	15in / 38.1cm	20.4in / 51.8cm	47lbs / 21.4kg

ELECTRICAL SPECIFICATIONS

Model No.	Voltage	Wattage	Amps	NEMA Plug
CCOHS-3	120V	1,440	12	5-15
CCOQS-3	120V	1,440	12	5-15

OVEN FEATURE	CCOQS-3	CCOHS-3
<i>Number of Racks</i>	3	3
<i>Domestic Sheet Size</i>	1/4	1/2
<i>Inner Oven Chamber</i>	Stainless Steel	Stainless Steel
<i>Number of Motors/Fan(s)</i>	1	1
<i>Reversible Motors</i>	no	no
<i>Number of Interior Lights</i>	0	1
<i>Top Browning Element</i>	no	yes
<i>Steam Feature</i>	no	no
<i>Manual Reset Hi-Limit Protection</i>	yes	yes
<i>Door Interlock Switch</i>	yes	yes
Timer		
<i>Single "Ding"</i>	yes	yes
<i>Electronic</i>	no	no



WARNING

THIS APPLIANCE MUST BE GROUNDED AT THE TERMINAL PROVIDED. FAILURE TO GROUND THE APPLIANCE COULD RESULT IN ELECTROCUTION AND DEATH.

INSTALLATION OF THE UNIT MUST BE DONE BY PERSONNEL QUALIFIED TO WORK WITH ELECTRICITY AND PLUMBING. IMPROPER INSTALLATION CAN CAUSE INJURY TO PERSONNEL AND/OR DAMAGE TO EQUIPMENT. UNIT MUST BE INSTALLED IN ACCORDANCE WITH ALL APPLICABLE CODES.

NOTICE

The data plate is located on the lower right side panel of the unit. The oven voltage, wattage, serial number, and clearance specifications are on the data plate. This information should be carefully read and understood before proceeding with the installation.

NOTICE

The installation of this unit must conform to applicable national, state and locally recognized installation standards.

NOTICE

The installation of any components such as a vent hood, grease extractors, fire extinguisher systems, must conform to their applicable National, State and locally recognized installation standards.



CAUTION

MOST CLEANERS ARE HARMFUL TO THE SKIN, EYES, MUCOUS MEMBRANES AND CLOTHING. PRECAUTIONS SHOULD BE TAKEN TO WEAR RUBBER GLOVES, GOGGLES OR FACE SHIELD AND PROTECTIVE CLOTHING. CAREFULLY READ THE WARNING AND FOLLOW THE DIRECTIONS OF THE LABEL OF THE CLEANER TO BE USED.



WARNING

KEEP WATER AND SOLUTIONS OUT OF CONTROLS. NEVER SPRAY OR HOSE CONTROL CONSOLE, ELECTRICAL CONNECTIONS, ETC.

BOTH HIGH AND LOW VOLTAGES ARE PRESENT INSIDE THE APPLIANCE WHEN THE UNIT IS PLUGGED/WIRED INTO A LIVE RECEPTACLE. BEFORE REPLACING ANY PARTS, DISCONNECT THE UNIT FROM THE ELECTRIC POWER SUPPLY.

NOTICE

Never use chlorine sanitizer in contact with stainless steel surfaces longer than 10 minutes. Longer contact can cause corrosion.

NOTICE

Service this, or any other Superior appliance must be performed by qualified personnel only. Consult your authorized service station directory or call the factory (at 1-800-807-9054), or log onto www.star-mfg.com for the service agent nearest you.



GENERAL INFORMATION

This equipment is designed and sold for commercial use only by personnel trained and experienced in its operation and is not sold for consumer use in and around the home nor for use directly by the general public in food service locations.

Before using your new equipment, read and understand all the instructions & labels associated with the unit prior to putting it into operation. Make sure all people associated with its use understand the units operation & safety before they use the unit.

All shipping containers should be checked for freight damage both visible and concealed.

This unit has been tested and carefully packaged to insure delivery of your unit in perfect condition. If equipment is received in damaged condition, either apparent or concealed, a claim must be made with the delivering carrier.

Concealed damage or loss - if damage or loss is not apparent until after equipment is unpacked, a request for inspection of concealed damage must be made with carrier within 15 days. Be certain to retain all contents plus external and internal packaging materials for inspection. The carrier will make an inspection and will supply necessary claim forms.

PURCHASER'S RESPONSIBILITY

It is the responsibility of the purchaser:

1. To see that the electric services for the oven are installed on site in accordance with the manufacturer's specifications and in compliance with all local codes.
2. To unload, un-crate, and install the oven in its proper location and in accordance with this installation operation manual.
3. To see that electric services are connected properly by a qualified installer of your choice.

UN-CRATING

The oven will arrive completely assembled and ready to use. Prior to un-crating move the oven as close to its final location as practical. This will protect it from damage associated with moving (scratches, dings, dropping).

These ovens weigh between 47 & 140 lbs. For safe handling, installer should obtain help as needed, or employ appropriate materials handling equipment (such as a forklift, dolly, or pallet jack) to remove the unit from the container and move it to the place of installation.



ANY STAND COUNTER OR OTHER DEVICE ON WHICH THE OVEN WILL BE LOCATED MUST BE DESIGNED TO SUPPORT THE WEIGHT OF THE OVEN.



NEVER lay oven with the control side down, this will damage the controls.

INSTALLATION

LOCATION

Do not install the Holman Counter top Convection Oven directly on the Floor. Superior has stands available to accommodate your new oven.

CAUTION

DO NOT install oven closer than 1" on the control side, from another oven.

DO NOT install oven closer than 12" on the control side, from a uncontrolled heat source (char broiler, open flame, griddle, etc.), unless a Hi-Temperature Spacer is installed then it can be reduced to 1".

ELECTRICAL

The ovens are equipped for the voltage indicated on the nameplate mounted on the lower right side panel of the oven. They will operate on alternating current (AC) only. A cord & plug is provided installed.

All electrical connections must be made by a licensed electrician and in accordance with local codes or in the absence of local codes with NFPA No. 70 latest edition (in Canada use: CSA STD. C22.1)



WARNING

DO NOT CONNECT TO DIRECT CURRENT (DC).

DO NOT CONNECT TO ANY OTHER TYPE OF CURRENT THAT IS OTHERWISE SPECIFIED FOR THIS SPECIFIC UNIT, OR MACHINE WILL BE SERIOUSLY DAMAGED.

AIR SUPPLY

Make certain not to obstruct the flow of combustion (gas) and ventilation air. Provisions for adequate air supply must be furnished.

LEVELING THE UNIT

This Superior Oven comes with legs installed at the factory, proper leveling is essential to receive a proper baking performance. Level unit by adjusting the (4) feet which have an adjustment of 1-3/4" (43.75mm) for accurate leveling.

OPERATION

INITIAL USE

Before using your Superior Counter Top Convection Oven for the first time, clean the unit using mild detergent and warm water, then heat for approximately 30 minutes. The grill may emit a small amount of smoke as the cooking surfaces reach 300-350°F (149-177°C). Do not be alarmed, as the smoke is caused by oils associated with the manufacturing process and will stop when the oven reaches 400°F (204°C).

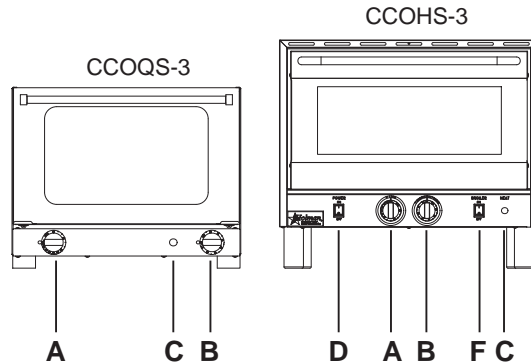

OVEN COMPONENTS DESCRIPTION

- A: Timer:** This can be set at any range between 0 thru 120 minutes, when the timer reaches 0 the unit will turn itself off. It also has a manual feature which will allow it to run continuously until it is removed from this setting.
- B: Temperature:** This sets the cooking temperature between 175°F to 500°F (79°C to 260°C).
- C: Indicator Light:** This light will illuminate when the oven is being brought up to the desired temperature, it will turn off when the desired set temperature is reached.
- D: On/Off Switch:** Makes it easy to see at a glance when the oven is operating.
- E: 1-Shot Steam:** Provides a single shot of steam into the cooking chamber. The oven must be at operating temperature to receive this benefit, and should only be used in shots of 5 seconds periods.
- F: Top Broiler Element:** Provides intense heat for broiling, browning and finishing menu items.
- G: Hi-Limit Reset:** Mounted on the rear of the unit, it monitors the inside cooking temperature and will only trip when the unit reaches a high temperature due to the unit being in an enclosed environment with no air cooling circulation.

TYPICAL OPERATION SEQUENCE

ACTION	RESULT
Press the ON/OFF switch.	Button lights up.
Adjust Temperature to desired setting and move timer to manual position.	Fan, heat and indicator light comes on. Fan will reverse only on CCOF-4 model.
Indicator lights shuts off.	Oven has reached desired temperature.
Load product into oven.	<i>See Hints & Suggestions - "Loading the Oven"</i> Fan will shut off when door is opened, this minimizes the heat loss.
Set Timer to desired cook time.	Timer starts timing down.
1-Shot Steam (CCOFS-4 model only)	<i>See Convection Oven Baking Guide, Convection Ovens In General</i>
Cooking timer times out.	When 0 is reached the fan and heat shuts off, and the ON/OFF switch remains lit.
Unload Oven	<i>See Hints & Suggestions - "Unloading the Oven"</i>

MAINTENANCE

Contact the factory, a service representative or a local service company for service or required maintenance. Replacement cord sets must be purchased from Star Manufacturing International, Inc.

- Oven interiors should be wiped down daily and thoroughly cleaned weekly using warm water and mild detergent. **DO NOT use caustic cleaners.**

CLEANING

- Always start with a cold oven.
- The stainless exterior can easily be cleaned using stainless steel cleaner.
- Always follow the cleaner manufacturer's instructions when using any cleaner.
- Care should be taken to prevent caustic cleaning compounds from coming in contact with the fan wheel.
- The oven racks, rack slides, may be cleaned outside the oven cavity using oven cleaner.
- Using any harsh chemicals will result in the removal of the ETC coating and etching of the porcelain below it. The oven interior should only be cleaned using a mild soap and a non metal scouring pad. **DO NOT use caustic cleaners.**
- Always apply stainless steel cleaners when the oven is cold and rub in the direction of the metal's grain.

KEEP WATER AND SOLUTIONS OUT OF CONTROLS. NEVER SPRAY OR HOSE CONTROL CONSOLE.

MOST CLEANERS ARE HARMFUL TO THE SKIN, EYES, MUCOUS MEMBRANES AND CLOTHING. PRECAUTIONS SHOULD BE TAKEN TO WEAR RUBBER GLOVES, GOGGLES OR FACE SHIELD AND PROTECTIVE CLOTHING.



WARNING

CAREFULLY READ THE WARNING AND FOLLOW THE DIRECTIONS ON THE LABEL OF THE CLEANER TO BE USED.

NEVER LEAVE A CHLORINE SANITIZER IN CONTACT WITH STAINLESS STEEL SURFACES LONGER THAN 10 MINUTES. LONGER CONTACT CAN CAUSE CORROSION.

CLEANING THE FAN

The fan located behind the rear panel should be cleaned periodically. Depending on the amount and type of use the unit receives, dirt & grime will build up on the fan, causing it to possibly shorten the life of the motor.

To clean simply:

1. Unplug unit and allow to cool.
2. Loosen screws shown here and remove rear panel.
3. Using damp cloth, wipe fan until clean.
4. Reassembly and test for proper operation.

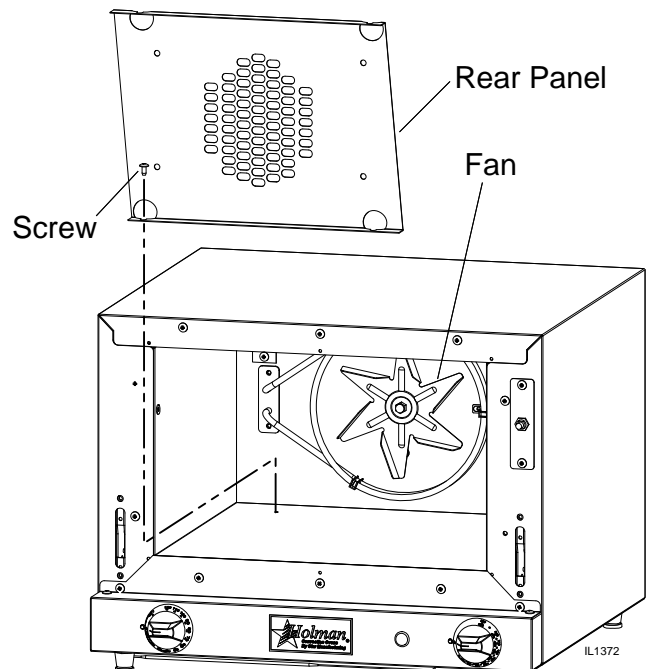

CONVECTION OVEN BAKING GUIDE

CONVECTION OVENS IN GENERAL

- Convection ovens constantly circulate air over the product. This strips away the thin layer of moisture laden air from the top of the product allowing heat to penetrate more quickly. This allows cooking times to be shortened and cooking temperatures reduced in convection ovens. Introducing steam into the cooking process prevents the bake from losing moisture and allows for a better product.
- Applying steam to dough during first 5 minutes, allows the yeast to work a little longer, allowing for better oven spring and loaf volume keeping the outer layer flexible and moist. Once the outside layer of the dough sets, gases in the loaf can no longer expand to increase the loaf size.
- Steaming the dough as it bakes also gelatinizes starch on the outside layer, producing a bread with a crisp crust and a brown crust color in varying degrees; too much steam results in an undesirable crust. Steam also helps to prevent wild breaks in the loaves because it delays the setting of the bread's crust, allowing it more time to bake and brown. However, in contrast, during the last stages of baking, a dry oven is required when the crust is browning; after the steam is removed, the gelatinized layer dries out forming a thick crunchy crust.
- The convection oven is an electromechanical piece of equipment and is designed to produce a consistent result. Variations in results are therefore more likely due to differences in the preparation process.

BAKING HINTS

- Always maintain a consistent cooking process. Establish a process that works for you, write it down and stick to it. Consistency in your cooking processes is very important to the quality of your bake.
- Always weigh your product. This will give you a more consistent size, color and quality.
- Do not overload pans or space product unevenly in the pan as this will create a uneven bake.
- Bent or warped pans can greatly affect the evenness of the bake.
- Always use the oven lights to view the product through the oven door windows. Do not open the oven doors during baking as this will change the baking characteristics and produce erratic results.
- If using baker's parchment, be sure the parchment does not blow over the product or obstruct air flow in any way. This will create a uneven bake. Never use aluminum foil in your convection oven.
- Use proper sheet pans for baking. Aluminum pans have better heat transference than steel pans and therefore yield much better bake results.

LOADING THE OVEN

- When loading the oven, stage products and racks so the oven doors are opened for the least amount of time during the loading process to minimize the loss of heat inside the oven.
- Center each pan on the oven shelves. Spaces should be maintained equally between the pan edges and the oven walls, front and back. This will allow for an even distribution of airflow. The better the air flow around the product, the better and more consistent the bake.
- Load the pans on the shelves as close to equal distant apart as possible. Even vertical spacing of the pans on shelves 1 thru 3 or 4 inside the oven is important to the proper circulation of air and therefore will have an effect on the quality of your bake.
 - When loading the oven randomly, (Different times for different shelves) load the oven from the center shelf out with even vertical spacing.
 - When loading multiple pans at the same time, load the shelves spaced as equal distant as possible with even vertical spacing.

UNLOADING THE OVEN

- Unload the top shelf before the bottom shelves. This is necessary because it is a characteristic of all ovens that, after the fan shuts down, rising heat and the hot oven ceiling causes the top shelf to bake quicker. This characteristic is more pronounced when baking at higher temperatures and/or for prolonged periods of time.
- Always stage your product racks so that you can unload quickly with the door open for a minimal amount of time. This is to preserve the temperature inside the oven cavity for your next round of baking.



ALWAYS KEEP THE AREA NEAR THE UNIT FREE FROM COMBUSTIBLE MATERIALS.

KEEP FLOOR IN FRONT OF EQUIPMENT CLEAN AND DRY. IF SPILLS OCCUR, CLEAN IMMEDIATELY TO AVOID THE DANGER OF SLIPS OF FALLS.

Visit our Website at: www.star-mfg.com

Email: service@star-mfg.com

THOROUGHLY INSPECT YOUR UNIT ON ARRIVAL

This unit has been tested for proper operation before leaving our plant to insure delivery of your unit in perfect condition. However, there are instances in which the unit may be damaged in transit. In the event you discover any type of damage to your product upon receipt, you must immediately contact the transportation company who delivered the item to you and initiate your claim with same. If this procedure is not followed, it may affect the warranty status of the unit.

LIMITED EQUIPMENT WARRANTY

All workmanship and material in Star products have a one (1) year limited warranty on parts & labor in the United States and Canada. Such warranty is limited to the original purchaser only and shall be effective from the date the equipment is placed in service. Star's obligation under this warranty is limited to the repair of defects without charge, by the factory authorized service agency or one of its sub-agencies. Models that are considered portable (*see below*) should be taken to the closest Star service agency, transportation prepaid.

- > Star will not assume any responsibility for loss of revenue.
- > On all shipments outside the United States and Canada, see International Warranty.
- * The warranty period for the Ultra-Max, Hot Plates, Griddles, Charbroilers is (3) years parts & labor.
- * The warranty period for the Star-Max, Charbroilers, Griddles, Hot Plates, Fryers & Finishing Oven is (2) years parts & labor.
- * The warranty period for the JetStar six (6) ounce & Super JetStar eight (8) ounce series popcorn machines is two (2) years.
- * The warranty period for the Chrome-Max Griddles is five (5) years on the griddle surface. See detailed warranty provided with unit.
- * The warranty period for Teflon/Dura-Tec coatings is one year under normal use and reasonable care. This warranty does not apply if damage occurs to Teflon/Dura-Tec coatings from improper cleaning, maintenance, use of metallic utensils, or abrasive cleaners, abrasive pads, product identifiers and point-of-sale attachments, or any other non-food object that comes in continuous contact with the roller coating. This warranty does not apply to the "non-stick" properties of such materials.
- > This warranty does not apply to "Special Products" but to regular catalog items only. Star's warranty on "Special Products" is six (6) months on parts and ninety (90) days on labor.
- > This warranty does not apply to any item that is disassembled or tampered with for any purpose other than repair by a Star Authorized Service Center or the Service Center's sub-agency.
- > This warranty does not apply if damage occurs from improper installation, misuse, wrong voltage, wrong gas or operated contrary to the Installation and Operating instructions.
- > This warranty is not valid on Conveyor Ovens *unless* a "start-up/check-out" has been performed by a Factory Authorized Technician.

PARTS WARRANTY

Parts that are sold to repair out of warranty equipment are warranted for ninety (90) days. The part only is warranted, the labor to replace the part is **NOT** warranted.

SERVICES NOT COVERED BY WARRANTY

1. Travel time and mileage rendered beyond the 50 mile radius limit
2. Mileage and travel time on portable equipment (*see below*)
3. Labor to replace such items that can be replaced easily during a daily cleaning routine, ie; removable kettles on fryers, knobs, grease drawers on griddles, etc.
4. Installation of equipment
5. Damages due to improper installation
6. Damages from abuse or misuse
7. Operated contrary to the Operating and Installation Instructions
8. Cleaning of equipment
9. Seasoning of griddle plates
10. Voltage conversions
11. Gas conversions
12. Pilot light adjustment
13. Miscellaneous adjustments
14. Thermostat calibration and by-pass adjustment
15. Resetting of circuit breakers or safety controls or reset buttons
16. Replacement of bulbs
17. Replacement of fuses
18. Repair of damage created during transit, delivery, & installation OR created by acts of God

PORTABLE EQUIPMENT

Star will not honor service bills that include travel time and mileage charges for servicing any products considered "Portable" including items listed below. These products should be taken to the Service Agency for repair:

- * The Model 510FD, 510FF Fryer.
- * The Model 526TOA Toaster Oven.
- * The Model J4R, 4 oz. Popcorn Machine.
- * The Model 518CMA & 526CMA Cheese Melter.
- * The Model 12MC & 15MC & 18MCP Hot Food Merchandisers.
- * The Model 12NCPW & 15NCPW Nacho Chip/Popcorn Warmer.
- * All Hot Dog Equipment **except Roller Grills & Drawer Bun Warmers.**
- * All Nacho Cheese Warmers **except Model 11WLA Series Nacho Cheese Warmer.**
- * All Condiment Dispensers **except the Model HPD & SPD Series Dispenser.**
- * All Specialty Food Warmers **except Model 130R, 11RW Series, and 11WSA Series.**
- * All QCS/RCS Series Toasters **except Model QCS3 & RCS3 Series.**
- * All Fast Steamer Models **except Direct Connect Series.**

ALL:

- * Pop-Up Toasters
- * Butter Dispensers
- * Pretzel Merchandisers
(Model 16PD-A Only)
- * Pastry Display Cabinets
- * Nacho Chip Merchandisers
- * Accessories of any kind
- * Sneeze Guards
- * Pizza Ovens
(Model PO12 Only)
- * Heat Lamps
- * Pumps-Manual

The foregoing warranty is in lieu of any and all other warranties expressed or implied and constitutes the entire warranty.

FOR ASSISTANCE

Should you need any assistance regarding the Operation or Maintenance of any Star equipment; write, phone, fax or email our Service Department. In all correspondence mention the Model number and the Serial number of your unit, and the voltage or type of gas you are using.

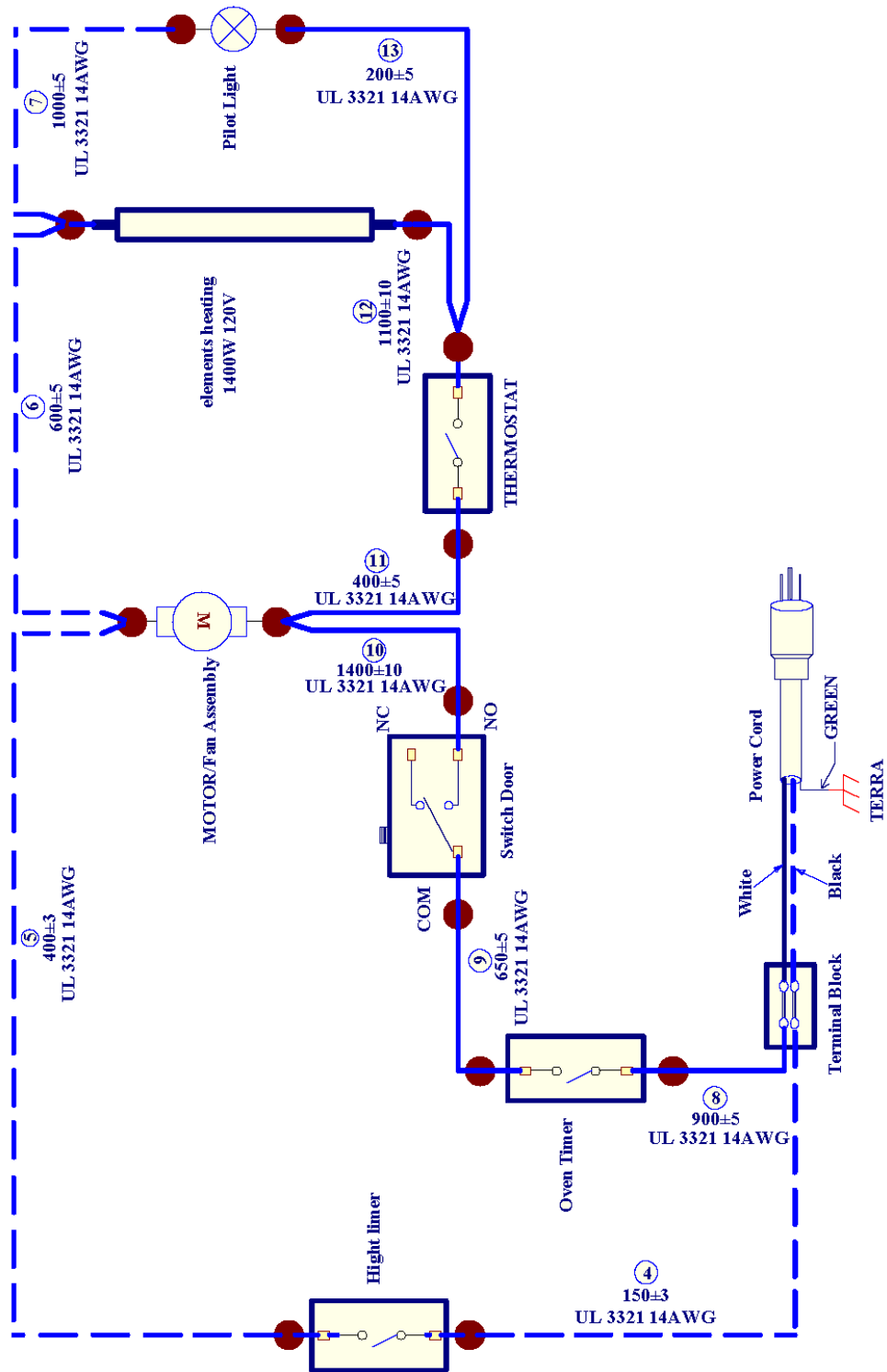

CCOQS-3 Convection Oven

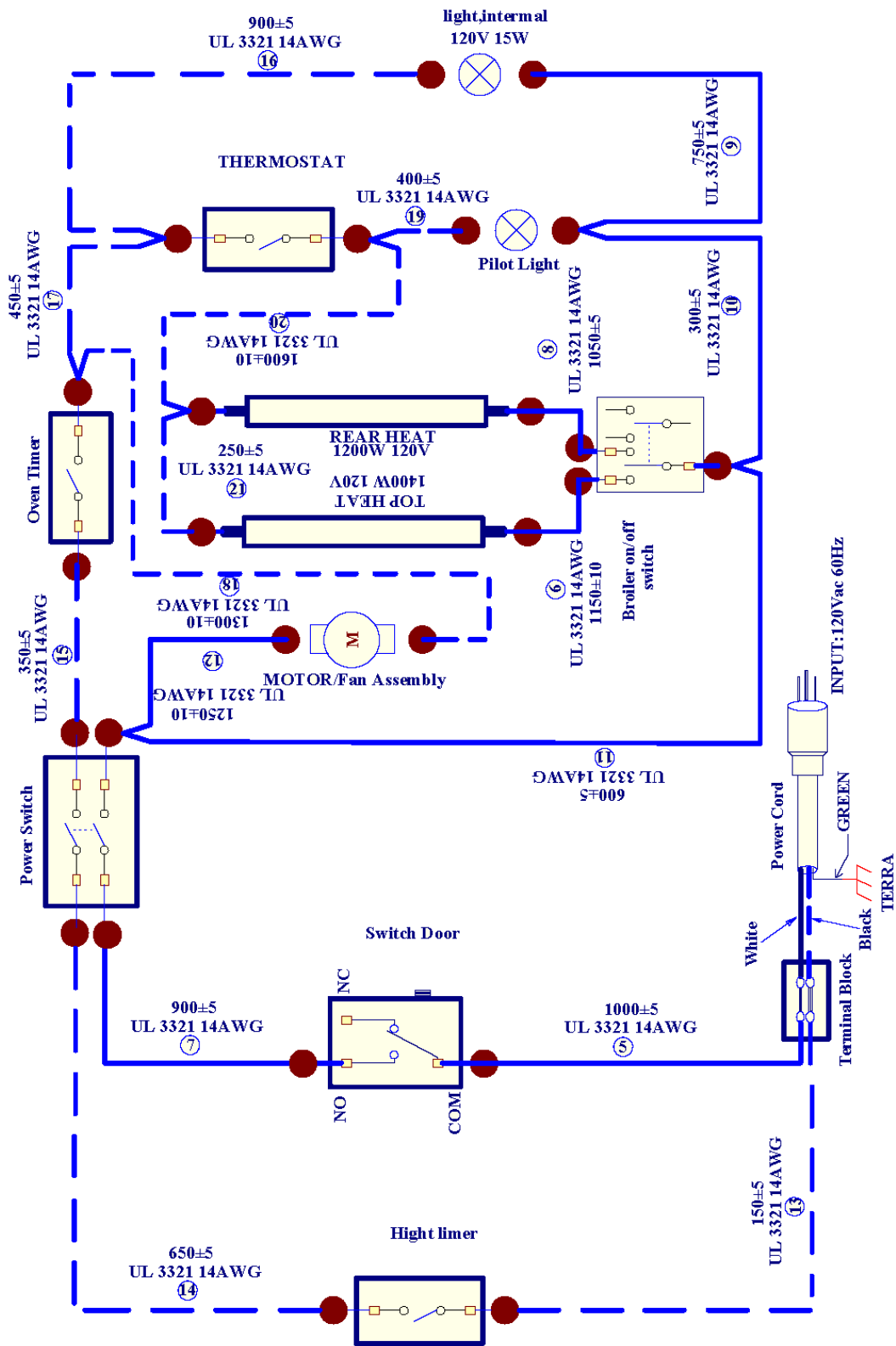

CCOHS-3 Convection Oven

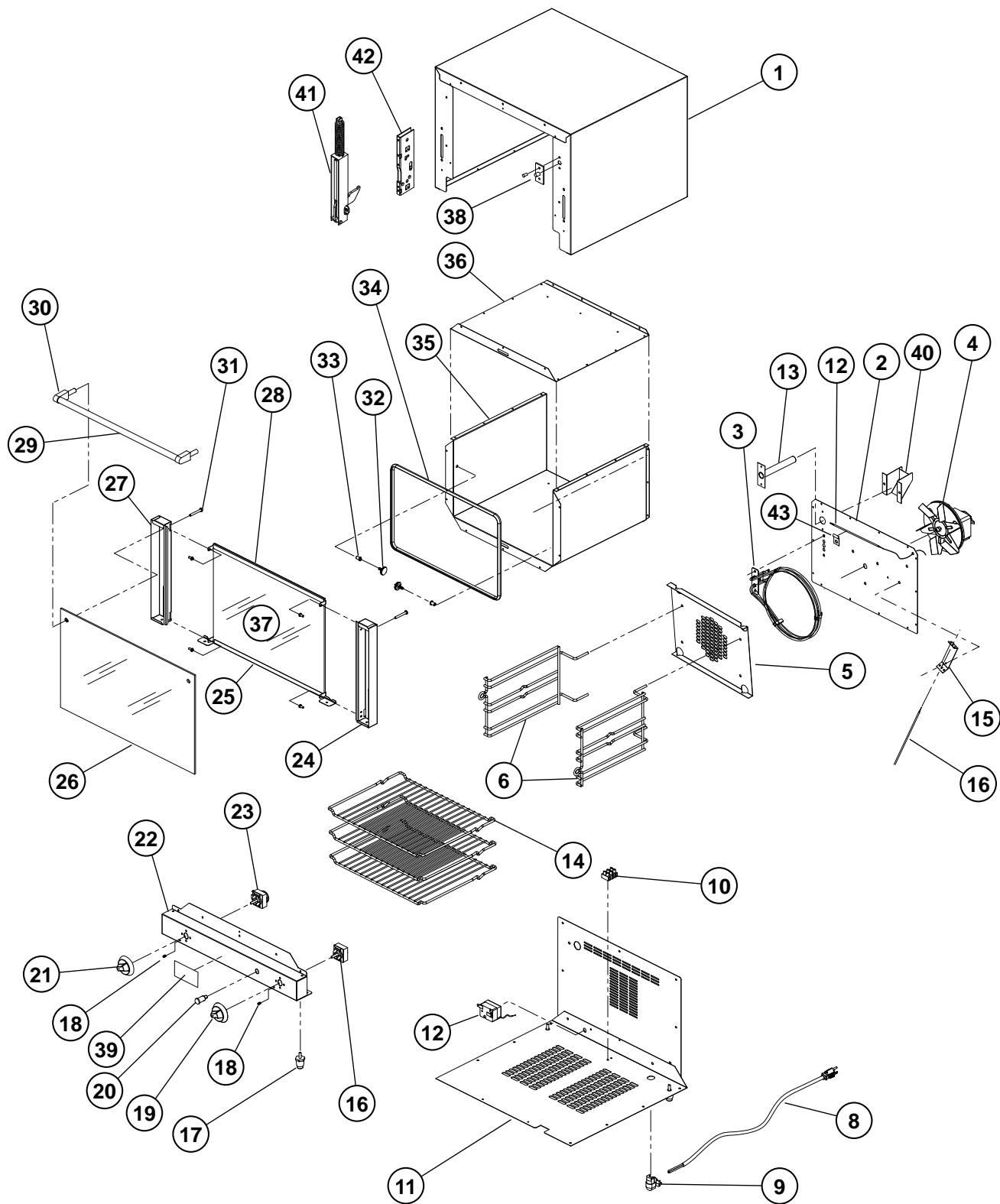

MODEL:
CCOQS-3 Electric Countertop Convection Oven



SK2266 Rev. A 9/12/2012

PARTS LIST

February 24, 2012, Rev. C

CCOQS-3 COUNTER TOP CONVECTION OVEN

Key Number	Part Number	Number Per Unit	Description
1	F9-Z10707	1	BODY WRAP
2	F9-Z10710	1	REAR, OVEN CHAMBER
3	2N-Z10735	1	ELEMENT 1400W, 120V
4	2U-Z10736	1	MOTOR/FAN ASSEMBLY
5	F9-Z10713	1	PANEL, AIR DISTRIBUTOR
6	2B-Z10743	2	L/R RACK SUPPORT
7	F9-Z10712	1	PANEL, REAR COVER-OVEN
8	2E-Z8861	1	CORD, POWER, 120V
9	2E-Z10730	1	STRAIN RELIEF
10	2E-Z10731	1	TERMINAL BLOCK
11	F9-CN0006	1	BODY BOTTOM PLATE ASSY
12	2E-Z10732	1	HIGH LIMIT
13	F9-CN0005	1	VENT TUBE
14	2B-Z10744	3	RACK
15	F9-Z10716	1	BRACKET, TSTAT PROBES
16	2T-Z10733	1	THERMOSTAT
17	2R-Z1485	4	FOOT 1" ADJUSTABLE
18	2E-Z10727	3	INDICATOR, RED RUBBER
19	2R-Z10724	1	KNOB, TEMPERATURE
20	2J-Z2329	1	PILOT LIGHT
21	2R-Z10723	1	KNOB, TIMER
22	F9-Z10711	1	PANEL, CONTROL
23	2E-Z10734	1	TIMER, OVEN
24	F9-Z10703	1	SUPPORT, DOOR RIGHT
25	F9-Z10705	1	SUPPORT, DOOR BOTTOM
26	2Q-Z10721	1	GLASS, OUTER
27	F9-Z10702	1	SUPPORT, DOOR LEFT
28	F9-Z10704	1	SUPPORT, DOOR TOP
29	2V-Z10741	1	ROD, HANDLE
30	2I-Z10726	2	HANDLE-END, DOOR
31	2C-1557	2	SCREW 10-24X1 1/2 RHP STL np
32	2C-Z10749	2	THUMBSCREW, SHELF
33	2C-Z10750	2	SCREW, SHELF RIVET
34	2I-Z10770	1	GASKET, DOOR
35	F9-Z10709	1	OVEN CHAMBER, BOTTOM
36	F9-Z10717	1	OVEN CHAMBER, TOP
37	2Q-Z10722	1	INNER GLASS, TEMPERED
38	PS-CN0064	1	CCOQ-3 DOOR SWITCH KIT (BRACKET, WIRE, SWITCH)
39	2M-Z10358	1	HOLMAN LOGO
40	F9-Z10763	1	HEAT SHIELD
41	2F-Z10745	2	HINGE, DOOR
42	2F-Z10769	2	RECEIVER, HINGE DOOR
43	2P-Z7670	2	HALF CLIP
NI	2C-Z10474	50	SCREW (BODY)
NI	2C-Z10748	3	SCREWS, MOTOR MOUNTING
NI	2C-Z10753	2	SCREW, TIMER
NI	2C-Z10756	6	SCREW, HINGE
NI	2C-Z10754	6	WASHER, HINGE
NI	2C-Z10757	2	SCREW, THERMOSTAT
NI	2C-Z10758	2	SCREW, BLOCK TERMINAL
NI	F9-CN0002	1	DOOR ASSEMBLY COMPLETE

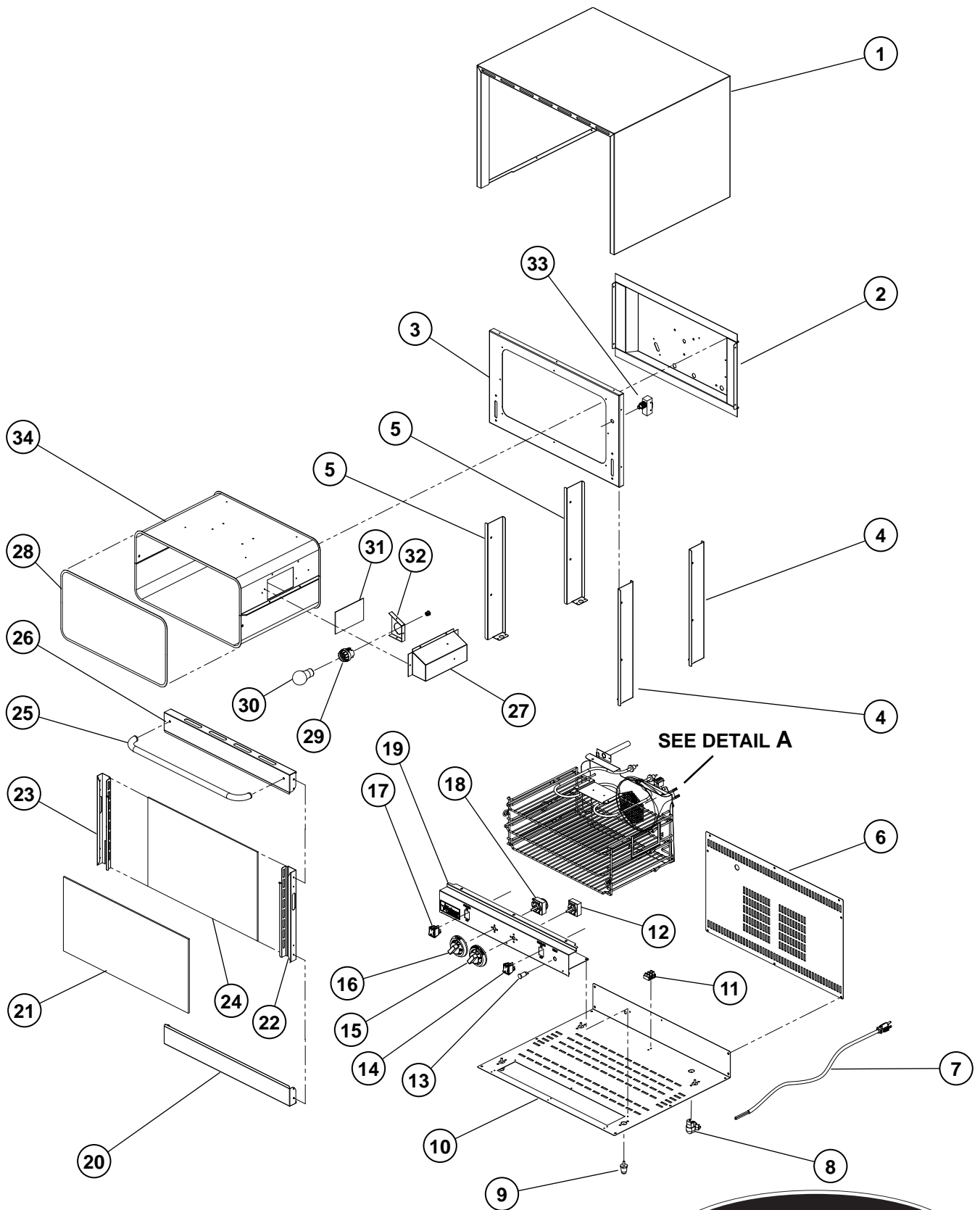

MODEL:
CCOHS-3 Electric Countertop Convection Oven

SK2267 Rev. A 9/16/09

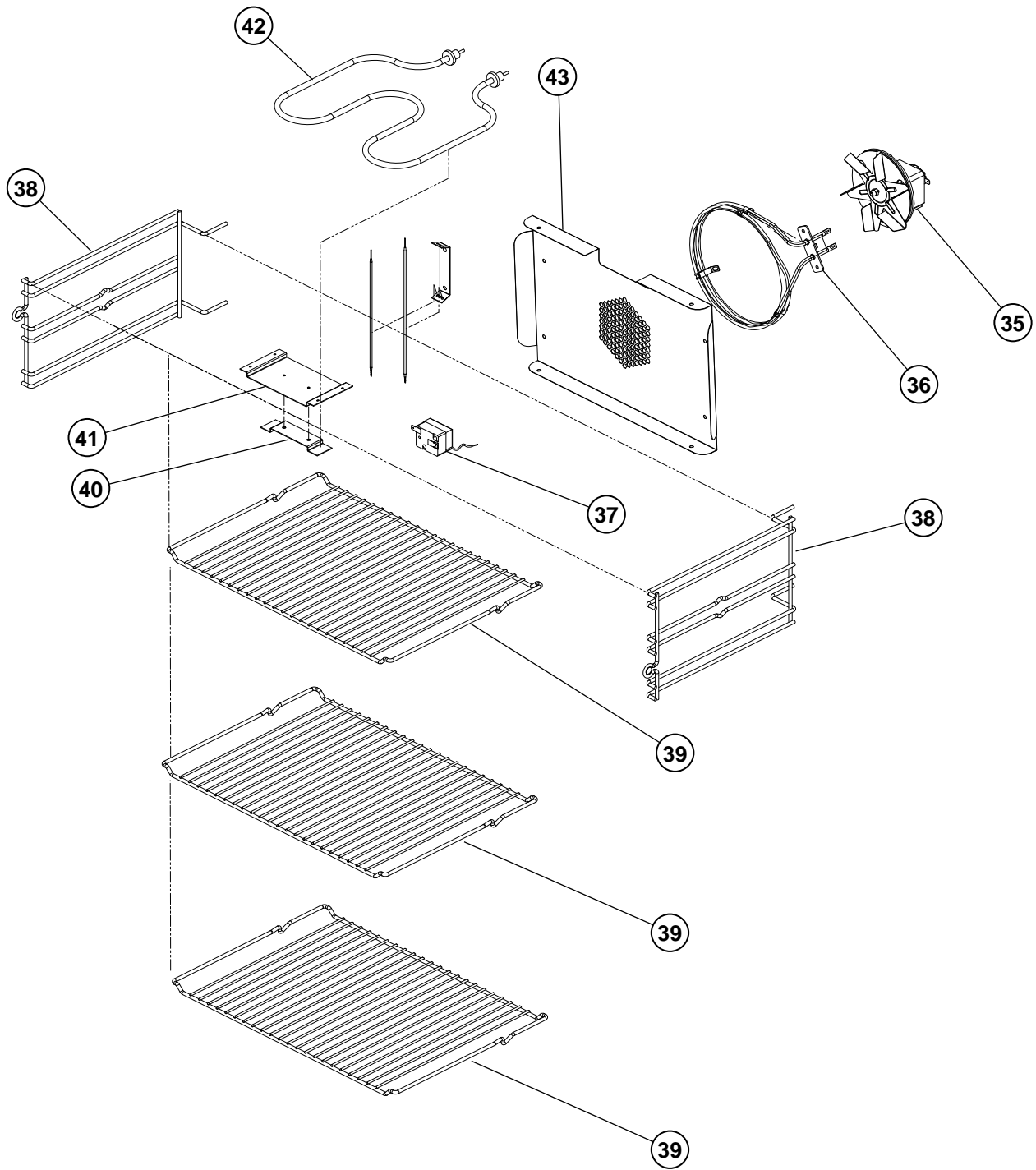

Detail A

MODEL:
CCOH-3

PARTS LIST

July 16, 2010, Rev. C

CCOHS-3 COUNTER TOP CONVECTION OVEN

Key Number	Part Number	Number Per Unit	Description
1	F9-Z10915	1	BODY WRAP
2	F9-Z10907	1	REAR, OVEN CHAMBER
3	F9-Z10906	1	FRONT FACE, OVEN CHAMBER
4	F9-Z10910	2	SUPPORT, OVEN CHAMBER RIGHT
5	F9-Z10909	2	SUPPORT, OVEN CHAMBER LEFT
6	F9-Z10913	1	PANEL, REAR COVER-OVEN
7	D9-Z8861	1	CORD, POWER, 120V
8	2E-Z10730	1	STRAIN RELIEF
9	2R-Y5092	4	FOOT
10	F9-Z10911	1	PLATE, BOTTOM OVEN
11	2E-Z10731	1	TERMINAL BLOCK
12	2T-Z10733	1	THERMOSTAT
13	2J-Z2329	1	PILOT LIGHT
14	2E-Z10950	1	SWITCH, BROILER
15	2R-Z12007	1	KNOB, TEMPERATURE
16	2R-Z10935	1	KNOB, TIMER
17	2E-Z10942	1	SWITCH, ON/OFF
18	2E-Z10734	1	TIMER, OVEN
19	F9-Z10912	1	PANEL, CONTROL
20	F9-Z10903	1	SUPPORT, DOOR BOTTOM
21	2Q-Z10932	1	GLASS, OUTER
22	F9-Z10901	1	SUPPORT, DOOR RIGHT
23	F9-Z10900	1	SUPPORT, DOOR LEFT
24	2Q-Z10933	1	GLASS, INNER
25	2V-Z10943	1	ROD, HANDEL
26	F9-Z10902	1	SUPPORT, DOOR TOP
27	F9-Z10917	1	LIGHT HOUSING
28	2I-Z10937	1	GASKET, DOOR
29	2E-Y9184	1	SOCKET, LIGHT
30	2S-1279	1	LIGHT BULB
31	2Q-Z10934	1	GLASS, LAMP COVER
32	F9-Z10916	1	LIGHT SOCKET HOLDER
33	PS-CN0063	1	CCOH-3 DOOR SWITCH KIT (<i>BRACKET, WIRE, SWITCH</i>)
34	F9-CN0019	1	OVEN CHAMBER WELD ASSY
35	2U-Z10736	1	MOTOR/FAN ASSEMBLY
36	2N-Z10735	1	ELEMENT 1400W, 120V
37	2E-Z10732	1	HIGH LIMIT
38	2B-Z10945	2	L/R RACK SUPPORT
39	2B-Z10944	3	RACK
40	F9-Z10919	1	TOP HEATING ELEMENT BRACKET
41	F9-Z10918	1	BRACKET, SUPPORT HEATING ELEMENT
42	2N-Z10939	1	ELEMENT, TOP, 1400W/120V
43	F9-Z10908	1	PANEL, AIR DISTRIBUTOR
NI	2F-Z10946	2	HINGE, DOOR
NI	F9-CN0016	1	DOOR ASSEMBLY COMPLETE

STAR INTERNATIONAL HOLDINGS INC. COMPANY
Star - Holman - Lang - Wells - Bloomfield - Toastmaster
10 Sunnen Drive, St. Louis, MO 63143 U.S.A.
(314) 678-6303
www.star-mfg.com