



**Star
Manufacturing
International Inc.**

10 Sunnen Dr.
St. Louis, MO 63143

Phone: (314) 781-2777
FAX: (314) 781-3636

**Installation
and
Operating
Instructions**

2M-Z1185 Rev. - 3/26/97

TOASTSWELL AUTOMATIC SPEED GRILL

Model# CG130A



INSTALLATION AND OPERATING INSTRUCTIONS

INSTALLATION

For your protection, we recommend that a qualified electrician install this appliance. The electrician should be familiar with electrical installations and your local electrical requirements. Proper connections and power supply are essential for efficient performance. The supply circuit should be properly fused as required by local electrical code.

Plug into any 110-120V A.C. outlet. Slow performance will indicate the grill is connected to a line of insufficient capacity or to one already loaded to capacity. Unless you have ordered a 220V Speed Grill, do not plug into a 220V line. Doing so will ruin the elements very quickly and void the guarantee. If this appliance does not heat, check plug and receptacle for loose connections.

OPERATING PROCEDURE

The thermostat dial is marked from 1 to 10. The #3 setting is approximately 200 degrees Fahrenheit. #7 is approximately 350 degrees Fahrenheit and #9 is approximately 400 degrees Fahrenheit. Set the dial to #7 and wait until the pilot light goes out. This indicates the temperature has been reached and the thermostat will automatically maintain proper temperature using current as needed. Do not attempt to cook food before the pilot light goes out. When starting from cold, food will stick to grids if they are not up to proper temperature. Setting thermostat to a higher temperature will not speed up the heating time. If grill is too hot, set dial at a lower temperature, if not hot enough, set at a higher temperature. Turn to "OFF" when the grill is not needed during slack periods.

PILOT LIGHT

The pilot light will glow while your grill is gaining temperature. It will wink on and off to show temperature is being maintained. The bulb burning out will not affect the operation of the grill.

COUNTER BALANCE TOP

Place the food to be prepared in the center of the cooking surface of the grill. Lower the upper grid. You will note, it has balanced itself at the desired height. There is no undue pressure from the upper grid on the food being prepared. Fresh bread, being very moist in itself, becomes quite soggy. Overcome this entirely by use of bread 1 or 2 days old. Oil both ends of the top hinge with 3 drops of oil every 30 days. Tilt the unit on end and drop 3 or 4 drops of oil down each end of the cylinder which holds the counterbalance spring only every 30 days.

GRID TILTER AND LEVELER

You can level your unit by adjusting the front legs. If you want to drain grease from grids as you cook you can tilt grill back by unscrewing front legs approximately 1/4" to 3/8". When in this or regular flat position, make sure the grease can is in place to catch grease. The round fat catcher slips under the drain lip. This can is not necessary, nor included with special Kmart units.

The grids are cast aluminum. They have been seasoned and silicon treated to prevent sticking. You may want to brush your meats and sandwiches with cooking oil as excessive moisture sometimes causes food to adhere to grids. Salt is the enemy of aluminum. Avoid its use until after the food is off the grill. When idling, set the grids 3/4" apart, this allows the extra heat to escape and reserve the seasoning. The counterbalance top will hold the grids in place.

CORD PLUG AND GROUNDING INSTRUCTIONS

For your protection, this appliance is equipped with a 3 conductor load cord, having a grounding type plug. A special grounding adaptor is available to permit the use of this appliance with conventional 2-wire receptacles on 115V only. To use the adaptor, first determine if this system is grounded. For grounded electrical systems, connect the green wire of the adaptor to the mounting screw on the receptacle. For wire of ungrounded electrical systems, attach the green adaptor to a known permanent ground.

CLEANING

All surfaces, except the cooking grids, are stainless steel and can be cleaned with a warm, damp cloth and detergent. The cooking surfaces are cast aluminum and will darken with use and should not be cleaned unless there is a carbon buildup. When buildup does occur, you can scrape with a spatula or with a scouring pad and cleaners. When this is done you should season grids with a good grade of vegetable oil before using.

For a small amount of carbon buildup:

1. Disconnect grill from power supply and allow to cool down.
2. Put a cloth or sponge in bottom grid and soak with soap-free ammonia. Close top grid and put a plastic bag around grids to help seal in vapors.
3. Let sit overnight and then take bag off and wipe or sponge off as much carbon as possible. Turn unit power on and when the grill is hot, brush off rest of carbon with a fiber brush. Then condition the grid with butter, release agent or butter substitute..

MAINTENANCE AND REPAIRS

Contact the factory or one of its representatives or a local service company for service or maintenance if required.

SERVICE BULLETIN

SUBJECT: COUNTERBALANCE TOP COOKING SURFACE

NUMBER: GR-0006

MODEL: ALL GRILLS

DATE: 2/14/96

Place food to be prepared in the center of the Bottom Cooking Surface of the Grill. Lower Top Cooking Surface and note the Lid has balanced itself. If there is more pressure than desired, on food being prepared the Top Cooking Surface can be adjusted.

TO ADJUST COUNTERBALANCE SPRING...

TO ADD MORE TENSION -

1. While LID is closed, twist SPRING COVER until it stops.
2. Put (1) TENSION PIN (C) into hole closest to HINGE ROD.
3. Raise LID until hole in the HINGE SHAFT lines up with the hole in the SPRING COVER.
4. Put second TENSION PIN (A) thru both holes.
5. Let LID down and remove the first TENSION PIN (C).
6. Reinstall first TENSION PIN (C) into hole closest to HINGE ROD.
7. Repeat process until desired tension is reached.

TO RELEASE TENSION -

1. While LID is closed, put loose TENSION PIN in the hole (B).
2. Raise LID and remove TENSION PIN (A) and reinstall it into next hole (forward).
3. Repeat process until desired tension is reached.

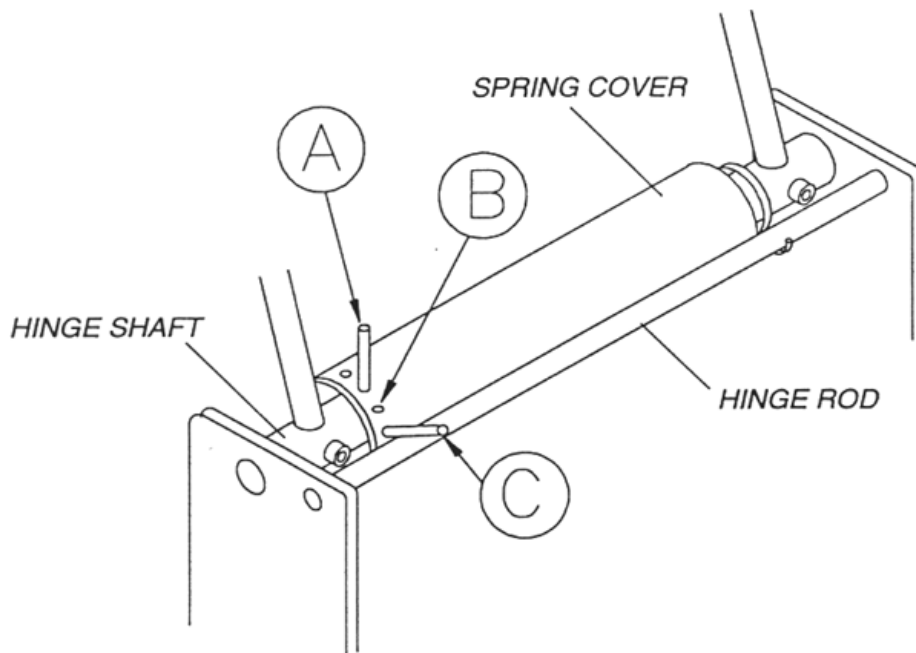

MONTHLY LUBRICATION -

HINGE SHAFT - Tilt unit on side, lubricate with 3 drops of non-toxic mineral oil, repeat process for other side.
SPRING COVER - Lubricate with 3 drops of non-toxic mineral oil while tilted on side.



The Toastswell Company

640 Tower Grove Ave • St. Louis, Missouri 63110
(314) 371-2732 • FAX (314) 371-2700

 a Standex company

SUPPLEMENTAL INSTRUCTIONS

SUBJECT: CARE FOR NON-COATED COOKING SURFACE

NUMBER: GR-0002

MODEL:

DATE: 5/18/95



DO NOT IMMERSE APPLIANCE IN WATER!

NOTE: The cooking surfaces will darken with use and do not require cleaning unless there is carbon build-up.

CLEANING LIGHT CARBON BUILD-UP

1. Turn OFF and unplug the appliance.
2. After allowing appliance to cool completely, move it to a well ventilated area.
3. Soak a cloth with ammonia and place onto bottom cooking surface, making sure the total cooking surface is covered.
4. Close top lid and place a plastic bag around the appliance. Seal the bag and let sit overnight.
5. Remove bag and sponge off carbon.
6. Rinse cooking surfaces with hot water and allow to dry.

CLEANING NORMAL CARBON BUILD-UP

1. Turn OFF and unplug the appliance.
2. After allowing appliance to cool completely, scrape cooking surface(s) with a spatula.
3. Scrub cooking surface(s) with a cleanser and scouring pad or steel wool, then rinse with hot water and allow to dry.

CLEANING HEAVY CARBON BUILD-UP

1. Turn OFF and unplug the appliance.
2. After allowing appliance to cool completely, clean cooking surfaces with Grid Cleaner "SOKOFF®" (Part No. 09-WB-2001), available locally by calling parts distributor.

NOTE: ALWAYS FOLLOW MANUFACTURER'S INSTRUCTIONS ON GRID CLEANER CONTAINER.

3. Rinse cooking surfaces with hot water and allow to dry.
4. After cleaning, coat surfaces with a thin layer of cooking oil.



The Toastswell Company

640 Tower Grove Ave • St. Louis, Missouri 63110
(314) 371-2732 • FAX (314) 371-2700

 a Standex company



**Star Manufacturing
International, Inc.**

10 Sunnen Drive
P.O. Box 430129
St. Louis, MO 63143

(800) 807-9054
(314) 781-2777
www.star-mfg.com

(800) 396-2677 Fax
(314) 781-2714 Fax

STAR Sandwich Grill Set Up, Seasoning and Cleaning

Set Up

1. Unpack the grill.
2. Read the Owners manual and then put it in a safe place for future reference.
3. If surface rust is visible, use a steel wool brush and scrub it off.
4. Wipe down the exterior and grilling area with a damp cloth.
5. Take the grill to a well ventilated area and turn the thermostat to 8-9. If your unit has an electronic control then set the temperature for 450°F. Allow the unit to burn off the factory oil. (the oil is there to prevent surface rust during shipping and storage)
6. The "burn off" is complete when the smoke is gone, approximately 30 minutes.
7. Brush any debris from the grill surfaces.
8. Allow the grill to cool and then place it in its permanent position.

First Time Seasoning

1. Bring the grill to 300°F and leave it on while doing the next three steps.
2. Spray the cooking area heavily with a baking release agent.
3. Let sit for 20 minutes.
4. Wipe surface clean with a warm, damp, cloth.

Daily Seasoning

The grill should not require much seasoning while in use. In most cases, a light spray of the baking release agent in the morning and occasionally throughout the day will be enough to prevent any sticking. It is not necessary to spray before grilling each item.

Daily Cleaning

1. If particles adhere to the cooking surface during the day, scrape them off with a spatula.
Note: It is best not to let food cook on to the grill, as build up of food on the grill will increase sticking and smoking. In addition, carbon may build up on the grill surface and reduce the cooking efficiency.
2. At the end of the day, wipe down all surfaces with a warm, damp, cloth and mild detergent. Dry with a soft towel.

Carbon Cleaning

When carbon build up occurs, use a carbon removal agent according to the instructions provided with the cleaner. When this process is completed, you must re-season the grill according to the First Time Seasoning instructions above.

***Please reference your owner's manual for additional information
concerning the operation of your grill.***



Ask for Quality and Performance by Name...Star and Holman
Commercial Gas and Electric Equipment for the Foodservice Industry.

MODELS CG130A, GR100, GR136, LG9, MG1 & SG4

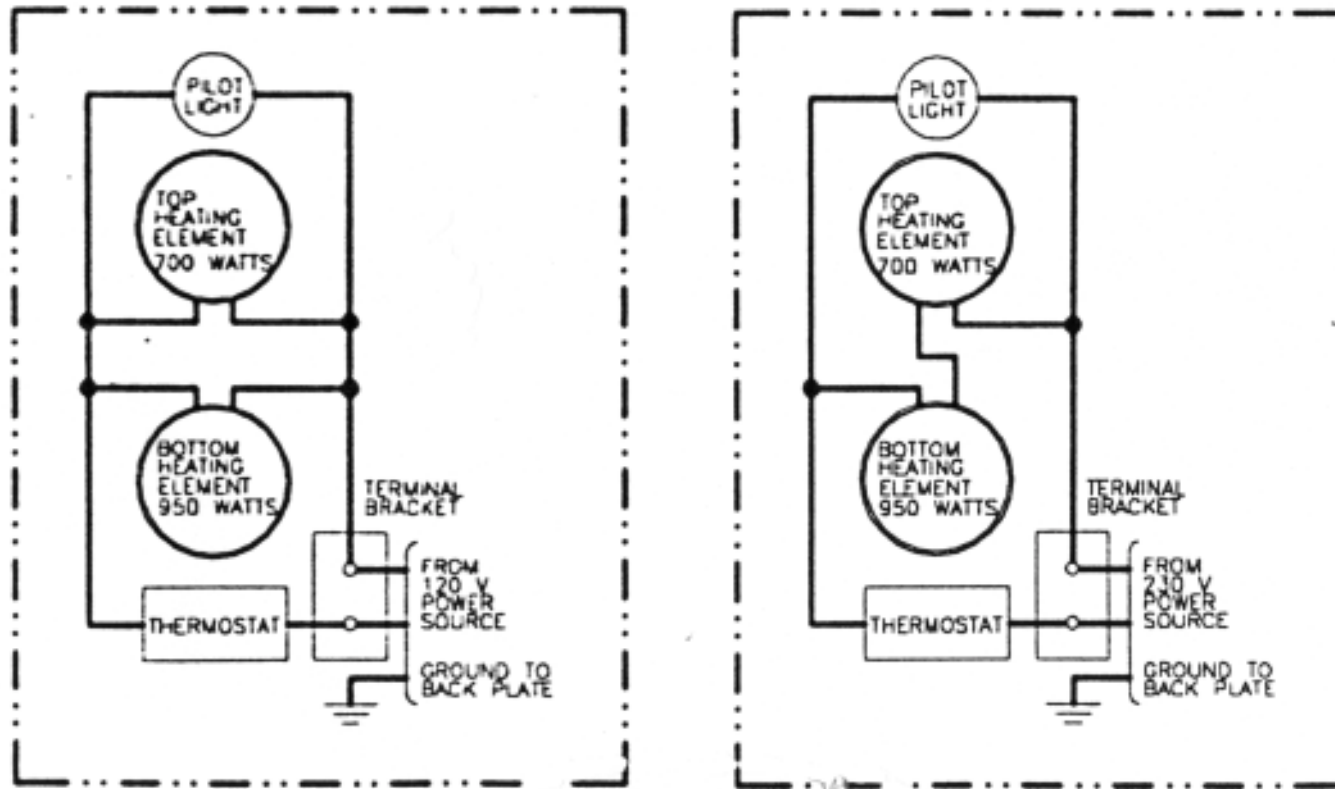

WIRING DIAGRAMS

CG130A
CG130A2T

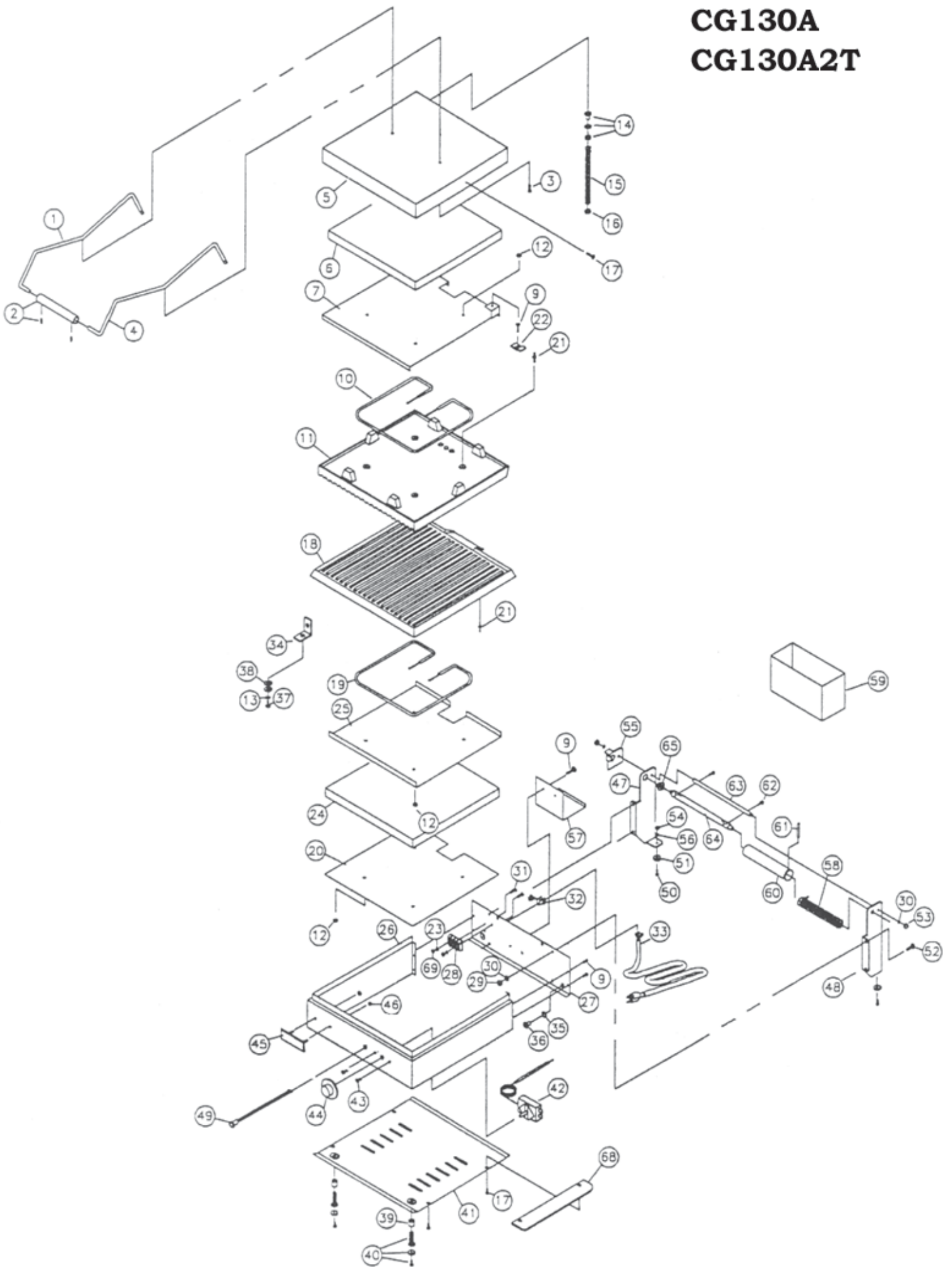

MODEL CG130A & CG130A2T

Key Number	Part Number	Number Per Unit	Description
1	D9-70-GR-0252	1	ROD: LEFT HANDLE
2	D9-52-GR-0175	1	BLACK HANDLE KIT w/SET SCREWS
3	2C-08-07-0001		SCREW, 10-32 x 5/8" (shoulder)
4	D9-70-GR-0253	1	ROD: RIGHT HANDLE
5	D9-30-GR-0013	1	HOUSING: UPPER
6	Z1-06-07-0026	1	INSULATION: 12" x 12"
7	D9-50-GR-0266	1	PLATE: ELEMENT
9	2C-08-07-0211		SCREW, #8 x 1/2 (self-drilling)
10	2N-05-GR-0165	1	ELEMENT, 700W (120V)
	2N-05-GR-0164	1	ELEMENT, 950W (240V)
11	D9-30-GR-0166	1	GRILLPLATE: NON-COATED TOP
12	2C-08-07-0207		NUT, 10-24 w/LOCKWASHER
13	2C-08-07-0093		LOCKWASHER, #10 (internal)
14	D9-40-GR-0001	1	FLEXIBLE CONDUIT CLAMP KIT No Longer Available
15	D9-05-GR-0029	1	CONDUIT: FLEXIBLE
16	2C-08-GR-0013	2	CLAMP: CONDUIT
17	2C-08-07-0230		SCREW, 8-32 x 17/32
18	D9-30-GR-0168	1	GRILL PLATE: NON-COATED BOTTOM
19	2N-05-GR-0166	1	ELEMENT, 950W (120V)
	2N-05-GR-0167	1	ELEMENT, 700W (240V)
20	D9-04-GR-0030	1	PLATE: ELEMENT
21	2C-08-07-0285		STUD, 10-24 w/SQUARE NUT
22	B9-04-WB-0046		CLAMP: WIRE SUPPORT
23	2C-08-07-0017		LOCKWASHER, # 8 internal
24	Z1-06-07-0031	1	INSULATION: 14" x 14"
25	D9-04-GR-0165	1	PLATE: ELEMENT
26	D9-04-GR-0089	1	HOUSING: LOWER
27	D9-04-GR-0079	1	COVER: BACK
28	2E-05-07-0057	1	TERMINAL: DOUBLEROW
29	2C-08-07-0107	1	NUT, 1/4-20
30	2C-08-07-0262		LOCKWASHER, 1/4 internal
31	2C-08-07-0042		SCREW, 8-32 X 5/8
32	2K-05-07-0017	1	STRAIN RELIEF: CORDSET
33	2E-05-07-0005	1	CORDSET: 120V (14/3, 5-15P, 42")
	2E-05-07-0052	1	CORDSET: 208/240V (14/3, 6-15P, 42")
	2E-05-07-0168	1	CORDSET: 120V-CANADIAN (14/3, 5-20P, 42")
34	D9-04-GR-0039	1	BRACKET: GRILLPLATE ANCHOR
35	2C-08-07-0050		LOCKWASHER, 3/8 internal
36	2C-08-GR-0011	2	BUSHING: CONDUIT
37	2C-08-07-0117		SCREW, 10-24 x 3/4
38	2C-08-07-0012		WASHER, 1/2" od x 18 ga
39	2A-09-GR-0023	4	SPACER: LEG, NYLON (BLACK)
40	D9-40-GR-0013	4	ADJUSTABLE LEG w/FOOT & SCREW
41	D9-30-GR-0012	1	BOTTOM COVER
42	2T-05-GR-0005	1	THERMOSTAT
43	2C-08-07-0037		SCREW, 6-32 x 3/8
44	2R-09-07-0006	1	KNOB: TEMPERATURE CONTROL
45	2M-Z1603	1	FACEPLATE
46	2C-08-07-0260		PALNUT
47	D9-70-GR-0168	1	LEFT HINGE BRACKET
48	D9-70-GR-0169	1	RIGHT HINGE BRACKET
49	2S-Z3823	1	INDICATOR LIGHT (120V)
	2S-05-07-0138	1	INDICATOR LIGHT (240V)
50	2C-08-07-0231		SCREW, 6-32 x 3/8

IMPORTANT: WHEN ORDERING, SPECIFY VOLTAGE OR TYPE GAS DESIRED

INCLUDE MODEL AND SERIAL NUMBER

Some items are included for illustrative purposes only and in certain instances may not be available.

PAGE 1OF 2

PARTS LIST

EFFECTIVE

01-23-06 RB

MODEL CG130A & CG130A2T

Key Number	Part Number	Number Per Unit	Description
51	2A-06-07-0027	4	FOOT: BLACK
52	2C-08-07-0261		SCREW, 1/4-20 x 3/4
53	2C-08-07-0040		NUT, 1/4-20 (acorn)
54	2C-08-07-0020		NUT, 6-32
55	D9-04-GR-0185	1	STOP: LID
56	2C-08-07-0059		LOCKWASHER, #6 internal
57	2C-08-07-0081	1	BRACKET: GREASE PAN
58	2P-09-GR-0001	1	SPRING: HINGE
59	2C-09-GR-0020	1	CONTAINER: GREASE (aluminum)
60	D9-70-GR-0051	1	TUBE: SPRING COVER
61	D9-70-GR-0045	2	PIN: SPRING RETAINER
62	2C-08-07-0066		SCREW, 10-32 x 3/8
63	2A-Z7275	1	ROD: HINGE
64	2A-Z7276	1	SHAFT: HINGE
65	2A-09-GR-0003	2	BUSHING: HINGE SHAFT
66	D9-04-GR-0040		SPACER STRIP: HOUSING
67	2C-08-07-0018		NUT, 8-32
NI	2M-12-GR-0039	1	LABEL: CAUTION
NI	2M-12-07-0034	1	LABEL: WARNING-HIGH VOLTAGE
NI	2M-12-07-0035	1	LABEL: WARNING-GROUNDED OUTLET
NI	2C-05-07-0004		CONNECTOR: WIRE
NI	2C-05-07-0059		TIE: WIRE
NI	Z1-30-07-0066		LEADWIRE: 18" NAT/WHT TGGT
NI	Z1-05-07-0018		SLEEVING: WHITE, 2.313" LONG
NI	2P-09-WB-0007	2	TIMER: BELL CG130A2T
NI	2C-09-WB-0005	2	BEZEL: TIMER CG130A2T
NI	2R-09-WB-0006	2	KNOB: TIMER CG130A2T
NI	2C-08-WB-0008	2	NUT: TIMER SHAFT CG130A2T

**IMPORTANT: WHEN ORDERING, SPECIFY VOLTAGE OR TYPE GAS DESIRED
INCLUDE MODEL AND SERIAL NUMBER**

PAGE 2
OF 2

Some items are included for illustrative purposes only and in certain instances may not be available.



Star Manufacturing International, Inc.