



**ISO 9001 : 2000 REGISTERED**

90 INDUSTRIAL PARK ROAD, SACO, ME/U.S.A. 04072  
(207) 282-1589 800-225-3958 FAX (207) 282-6283

OPERATORS MANUAL  
HOLMAN FINAL TOUCH FINISHING OVENS (MODEL FT1(W), FT2(W))  
HEAT AND HOLD OVENS (MODELS HH1(W), HH2(W))  
AND GARLIC BREAD TOAST AND HOLD OVEN (MODEL FT2BH(W))  
(For Service Information Call: 800-225-3958)

TABLE OF CONTENTS

UNCRATING AND INSPECTION	PAGE 1
ASSEMBLY	PAGE 1
WALL MOUNTING INSTRUCTIONS	PAGE 1
ELECTRICAL INSTALLATION	PAGE 1
COOKING PROCEDURES	PAGE 2
CLEANING (DAILY)	PAGE 2
TROUBLE SHOOTING GUIDE	PAGE 3 & 4
MAINTENANCE PROCEDURES	PAGE 5
PARTS LIST	PAGE 7

DRAWINGS

LEFT SIDE EXPLODED VIEW	PAGE 6
HEATER TUBE INSTALLATION	PAGE 5

WIRING DIAGRAMS

FT1, FT2	PAGE 8
FT2BH	PAGE 9
HH1, HH2	PAGE 10

OPERATORS MANUAL  
 HOLMAN FINAL TOUCH FINISHING OVENS (MODEL FT1(W), FT2(W)  
 HEAT AND HOLD OVENS (MODELS HH1(W), HH2(W)  
AND GARLIC BREAD TOAST AND HOLD OVEN (MODEL FT2BH(W))

### UNCRATING AND INSPECTION

Unpack unit and components from container. Remove all visible packing tapes and inspect unit for damage. If damage is discovered, file a claim immediately with carrier that handled the shipment.

### ASSEMBLY

If the unit is to be installed on a counter attach legs as shown.

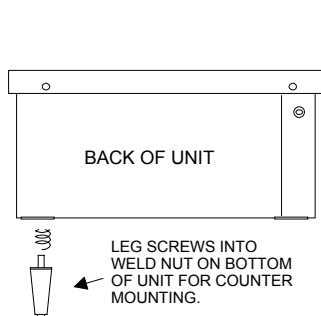

If the unit is to be wall mounted attach wall mounting brackets as shown.

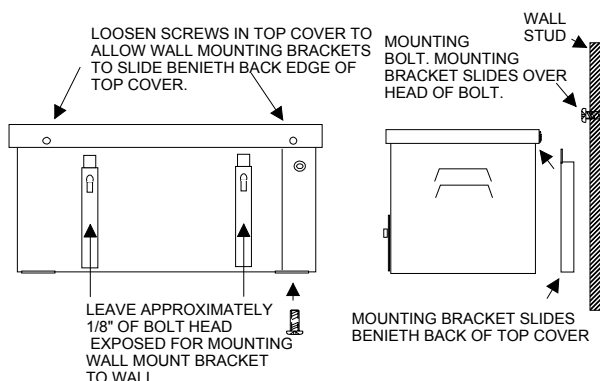

If unit is to be stacked, use the non-slip pads supplied with legs.  
 CAUTION - THE USE OF NON-SLIP PADS IS NOT N.S.F. APPROVED.

### ELECTRICAL INSTALLATION

**WARNING:** NEVER PLUG A 120 VOLT UNIT INTO 208 VOLTS OR 240 VOLTS. NEVER PLUG A 208 VOLT UNIT INTO 240 VOLTS OR A 240 VOLT UNIT INTO 208 VOLTS. CHECK WITH POWER COMPANY TO DETERMINE ACTUAL VOLTAGE AT THE JOB SITE BEFORE INSTALLING UNIT.

**WARNING:** BE ABSOLUTELY SURE THE GROUND CONNECTION FOR THE RECEPTACLE IS PROPERLY WIRED. NEVER CONNECT UNIT TO POWER WITHOUT PROPER GROUND CONNECTIONS. IMPROPER GROUND CONNECTION MAY RESULT IN SEVERE INJURY OR FATALITY.

Models FT1, FT2, HH1, and HH2, are furnished with a 4 foot cord and standard NEMA 5-15 plug for plug in installation in a grounded 120 Volt outlet. Model FT2BH is furnished with a 4 foot cord and NEMA 6-20 plug. Your HOLMAN oven should be the only appliance connected to the electrical line and should have its own fuse or breaker in the electrical box. Wall mounted models FT1W, FT2W, HH1W, and HH2W, are furnished with a 18" cord and standard NEMA 5-15 plug for plug in installation in a grounded 120 Volt outlet. Model FT2BHW is furnished with a 18" cord and NEMA 6-20 plug.

\*In Canada, models FT2 and HH2 are furnished with a 4 foot cord and NEMA 5-20 plug for plug-in installation in a 5-20R 20 amp receptacle. Model FT2BH is furnished with a 4 foot cord and NEMA 6-20 plug. Wall mounted models FT2W, and HH2W are furnished with a 18" cord and NEMA 5-20 plug for plug-in installation in a 5-20R 20 amp receptacle. Model FT2BHW is furnished with a 18" cord and NEMA 6-20 plug.

OPERATORS MANUAL  
HOLMAN FINAL TOUCH FINISHING OVENS (MODEL FT1(W), FT2(W))  
HEAT AND HOLD OVENS (MODELS HH1(W), HH2(W))  
AND GARLIC BREAD TOAST AND HOLD OVEN (MODEL FT2BH(W))

**OPERATION**

- A. Turn switch on. Panel light comes on; fan motor is activated; inferred radiant heaters are now at 1/4 power (total of 300 watts in FT1 and HH1; 400 watts in FT2 and HH2; 600 watts in FT2BH at 208 volts and 650 watts in FT2BH on 240 volts).
- B. Turn timer to 3 minutes to pre-heat the oven. Heaters glow and are now at full heat ( total of 1200 watts in FT1 and HH1; 1600 watts in FT2 and HH2; 2400 watts in FT2BH on 208 volts and 2600 watts on 240 volts).
- C. In models FT1, FT2 position slide shelf in one of the five shelf positions. Product should be placed on either a plate, tray or a sizzle platter, etc. In model FT2BH product can be set directly on the cooking rack.

There are five shelf positions in the FT1 and FT2. Since there are only two top heaters in these units, the intensity of heat can be varied by changing the position of the shelf. For example, place the shelf in the top position for quick melting of butter or cheese on breads or sandwiches. For baking fresh fish in a sizzle platter, place the shelf in the center position or in the lower position depending on the degree of baking required.

The HH1, HH2 and the FT2BH have two heaters above and two heaters below the pull-out rack (rack has one position).

- D. Set timer for desired cooking/heating time. The FT1 and FT2 have a 15 minute timer and the HH1, HH2 and FT2BH have a 6 minute timer. It takes only 10-15 seconds for the unit to go from HOLD to FULL POWER.
- E. When cooking/heating time has elapsed, timer shuts off and the oven automatically returns to HOLD mode.
- F. Product then can be removed or held warm for up to 10 minutes.

**CLEANING (DAILY)**

- A. Turn switch off. When oven has cooled;
  - 1. Remove shelf or rack. Clean with hot soapy water.
  - 2. Wipe interior and exterior surfaces with a damp cloth.

OPERATORS MANUAL  
 HOLMAN FINAL TOUCH FINISHING OVENS (MODEL FT1(W), FT2(W)  
 HEAT AND HOLD OVENS (MODELS HH1(W), HH2(W)  
 AND GARLIC BREAD TOAST AND HOLD OVEN (MODEL FT2BH(W))

**TROUBLE SHOOTING GUIDE**

**CAUTION - ALWAYS DISCONNECT UNIT FROM POWER SOURCE BEFORE SERVICING**

**A. UNIT WILL NOT HEAT, PANEL LIGHT DOES NOT COME ON.**

1. Be sure main circuit breaker is switched to the on position.
2. Check if oven is plugged in.

**B. PANEL LIGHT COMES ON, HEATERS DO NOT GET HOT.**

1. DISCONNECT UNIT FROM POWER SOURCE.
2. Check if heaters are properly installed as shown.

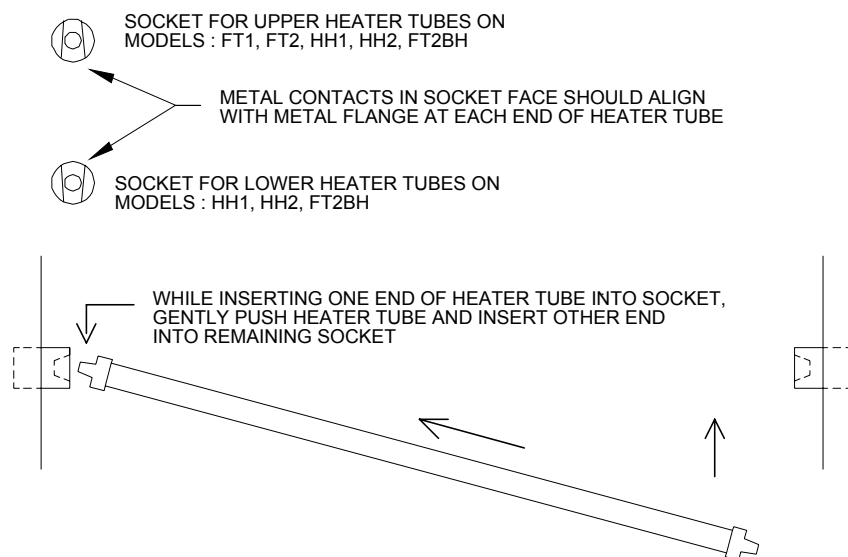

3. Press heat limit switch on back of unit as shown on page 4. If this reactivates the heaters, see HEAT LIMIT SWITCH (Section C).

OPERATORS MANUAL  
 HOLMAN FINAL TOUCH FINISHING OVENS (MODEL FT1(W), FT2(W)  
 HEAT AND HOLD OVENS (MODELS HH1(W), HH2(W)  
AND GARLIC BREAD TOAST AND HOLD OVEN (MODEL FT2BH(W)

**TROUBLESHOOTING GUIDE** (CONTINUED)

C. HEAT LIMIT SWITCH

Your Holman oven is equipped with an automatically activated temperature (heat) limit switch which interrupts the heater tube connections if the air temperature in the control box exceeds 190 degrees (F), 38 degrees (C). This heat limit switch can be reset manually by pushing a button located at the rear of the unit as shown below.

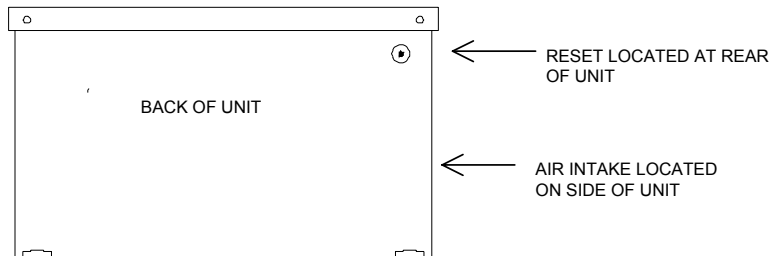

THIS HEAT LIMIT SWITCH IS ACTIVATED WHEN THERE IS NOT A PROPER AMOUNT OF AIR FLOW BEING GENERATED BY THE COOLING FAN. IF THIS OCCURS:

1. DISCONNECT UNIT FROM POWER SOURCE.
  2. Check to see if the air intake area (louvers in left side panel) is free of dust, grease or other obstructions.
  3. If no obstruction to the air intake can be found, call the Holman Cooking Equipment Department for assistance (the toll free number is on the unit).
- D. NO HEAT IN STANDBY MODE, ONE HEATER GLOWS WHEN OVEN IS SET FOR COOK OR HEAT MODES.
1. DISCONNECT UNIT FROM POWER SOURCE.
  2. Check if a heater tube is burnt out and , if so, replace it.
- E. PANEL LIGHT AND HEATER WORK, FAN DOES NOT COME ON.
1. DISCONNECT UNIT FROM POWER SOURCE.
  2. Call Holman cooking Equipment Department for assistance as fan motor must be checked and replaced if necessary. The toll free number is on the unit.

OPERATORS MANUAL  
 HOLMAN FINAL TOUCH FINISHING OVENS (MODEL FT1(W), FT2(W)  
 HEAT AND HOLD OVENS (MODELS HH1(W), HH2(W)  
AND GARLIC BREAD TOAST AND HOLD OVEN (MODEL FT2BH(W)

MAINTENANCE PROCEDURES

A. REPLACING HEATER TUBES (See below)

1. DISCONNECT UNIT FROM POWER SOURCE.
2. Gently pull old heater tube out of unit by pushing from left to right, then slowly guiding tube out of unit.
3. Gently put new heater tube into unit by placing tube end into socket and pushing into the spring loaded socket. Guide opposite end into other socket.

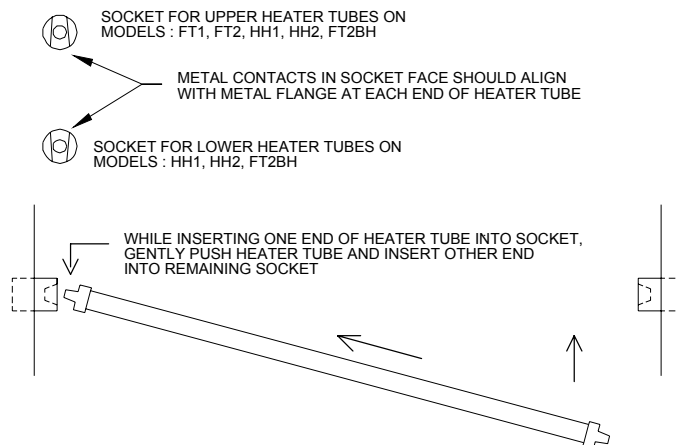

B. REPLACING FAN MOTOR

1. DISCONNECT UNIT FROM POWER SOURCE.
2. Remove screws from rear of top cover.
3. Remove top cover by lifting rear of cover and sliding forward as shown on page 6.
4. Carefully remove side panel with fan motor attached by lifting up and out from unit.
5. Unplug fan motor lead from fan motor.
6. Remove motor from side panel by removing four screws which hold motor and fan grill.

**OPERATORS MANUAL**  
**HOLMAN FINAL TOUCH FINISHING OVENS (MODEL FT1(W), FT2(W))**  
**HEAT AND HOLD OVENS (MODELS HH1(W), HH2(W))**  
**AND GARLIC BREAD TOAST AND HOLD OVEN (MODEL FT2BH(W))**

(Maintenance procedures cont.)

7. Using the same four screws, secure new fan motor to side panel and fan grill in the same manner as the old motor.
8. Reconnect fan motor lead to new motor in the same manner as old motor.
9. Keeping fan motor lead tucked away from fan blade, insert side panel on side of unit.
10. Replace top cover and secure with two screws.

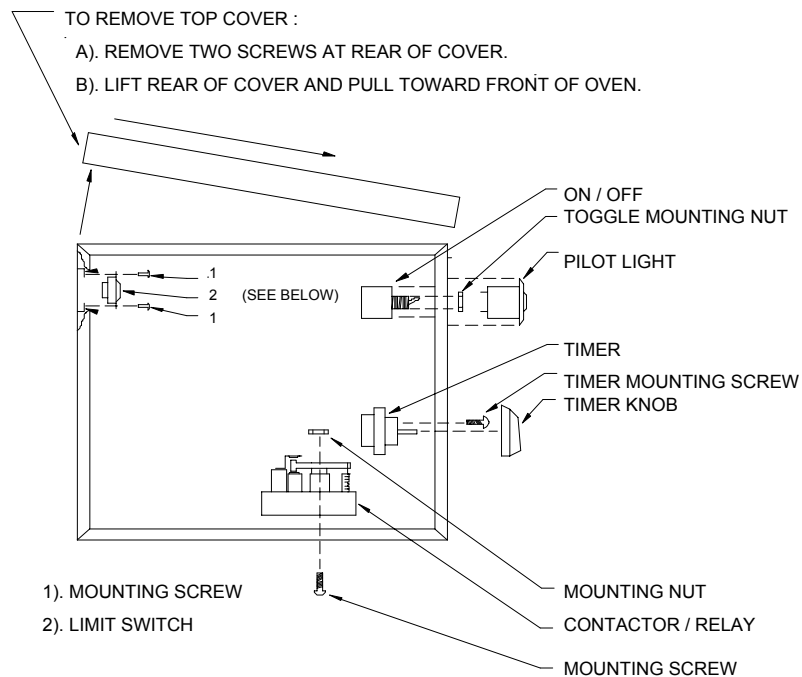
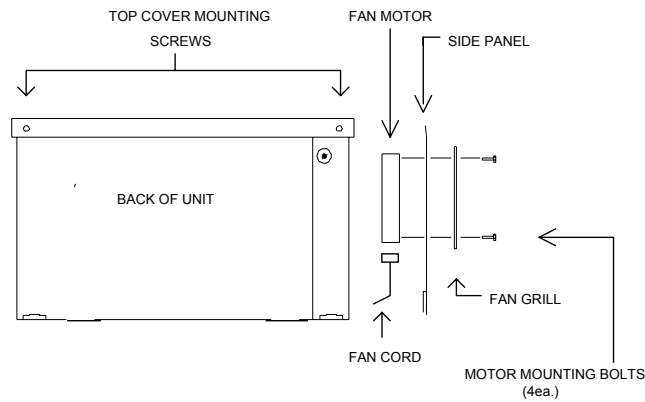

OPERATORS MANUAL  
 HOLMAN FINAL TOUCH FINISHING OVENS (MODEL FT1(W), FT2(W))  
 HEAT AND HOLD OVENS (MODELS HH1(W), HH2(W))  
AND GARLIC BREAD TOAST AND HOLD OVEN (MODEL FT2BH(W))

<u>PART #</u>	<u>QTY.</u>	<u>PAGE #</u>	<u>DESCRIPTION</u>
200543	1	6	ON/OFF Switch
200731	1	6	Timer, 6 minute HH1, HH2, FT2BH
200730	1	6	Timer, 15 minute FT1, FT2
200410	1	6	Panel Light
200409	4	Not Shown	Heater Tube Socket
187721	2	5	Heater Tube, FT1 (120V)
187719	2	5	Heater Tube FT2BH (208v)
187722	4	5	Heater Tube FT2BH (240v)
187723	2	5	Heater Tube, FT2 (120V)
187726	4	5	Heater Tube, HH1 (120V)
187728	4	5	Heater Tube, HH2 (120V)
200559	1	6	Fan Motor, FT1, FT2
200561	1	6	Fan Motor, FT2BH
200531	1	6	Contactactor/Relay FT1, FT2, HH1, HH2
200533	1	6	Contactactor/Relay, FT2BH
400757	1	Not Shown	Sliding Shelf, FT1
400766	1	Not Shown	Sliding Shelf, FT2
100701	1	Not Shown	Rack, FT2BH, HH2
100700	1	Not Shown	Rack, HH1
115146	1	6	Temperature Limit Switch
200562	1	6	Fan Grill
200387	1	6	Fan Cord
140034	1	Not Shown	Cord & Plug (120V) HH1, HH2, FT1, FT2
140035	1	Not Shown	Cord & Plug (208/240V) FT2BH

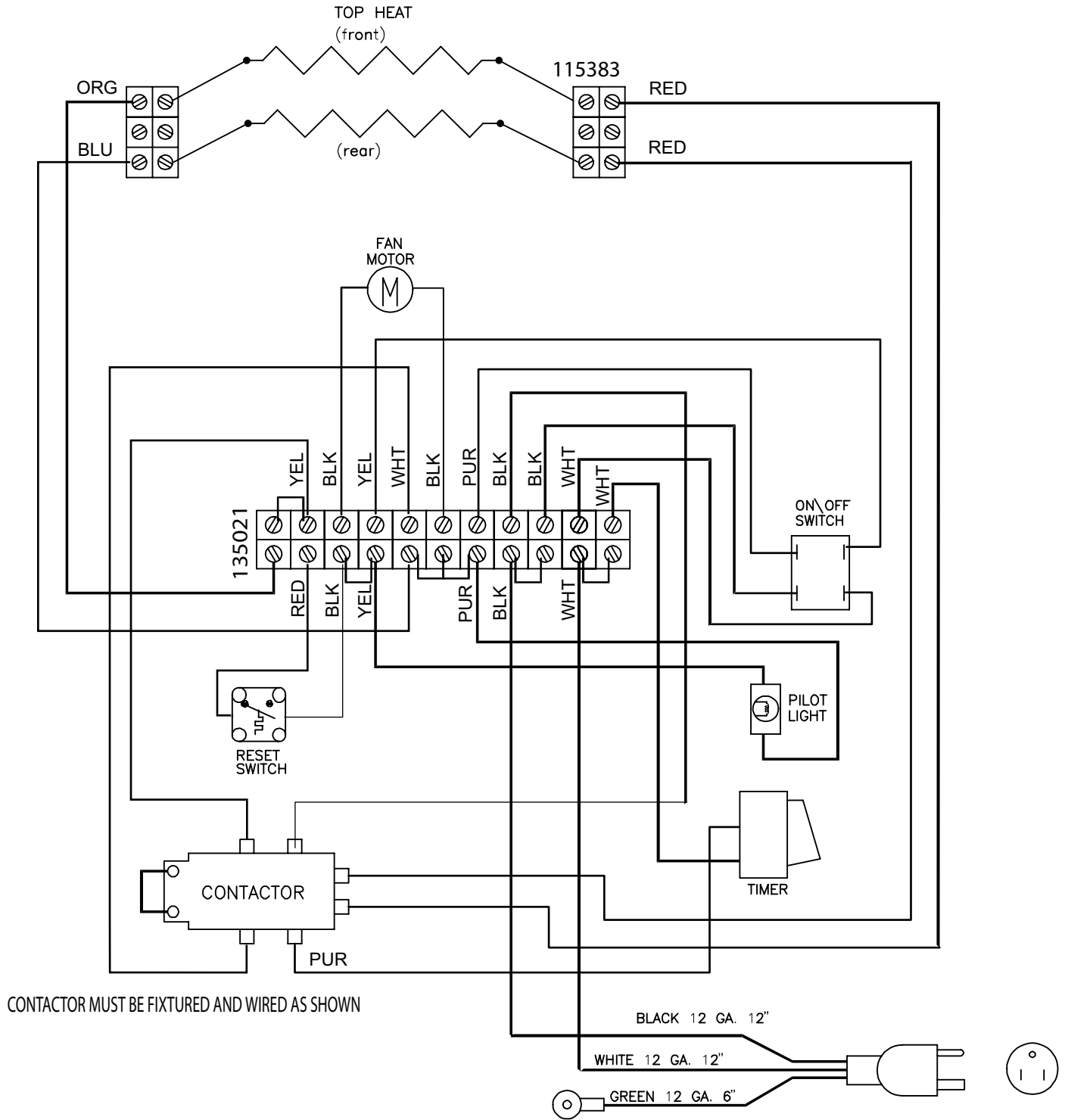

**MODELS:**

FT1 120/220/240V, 60Hz, 2 Tube  
 FT2 120/220/240V, 60Hz, 2 Tube



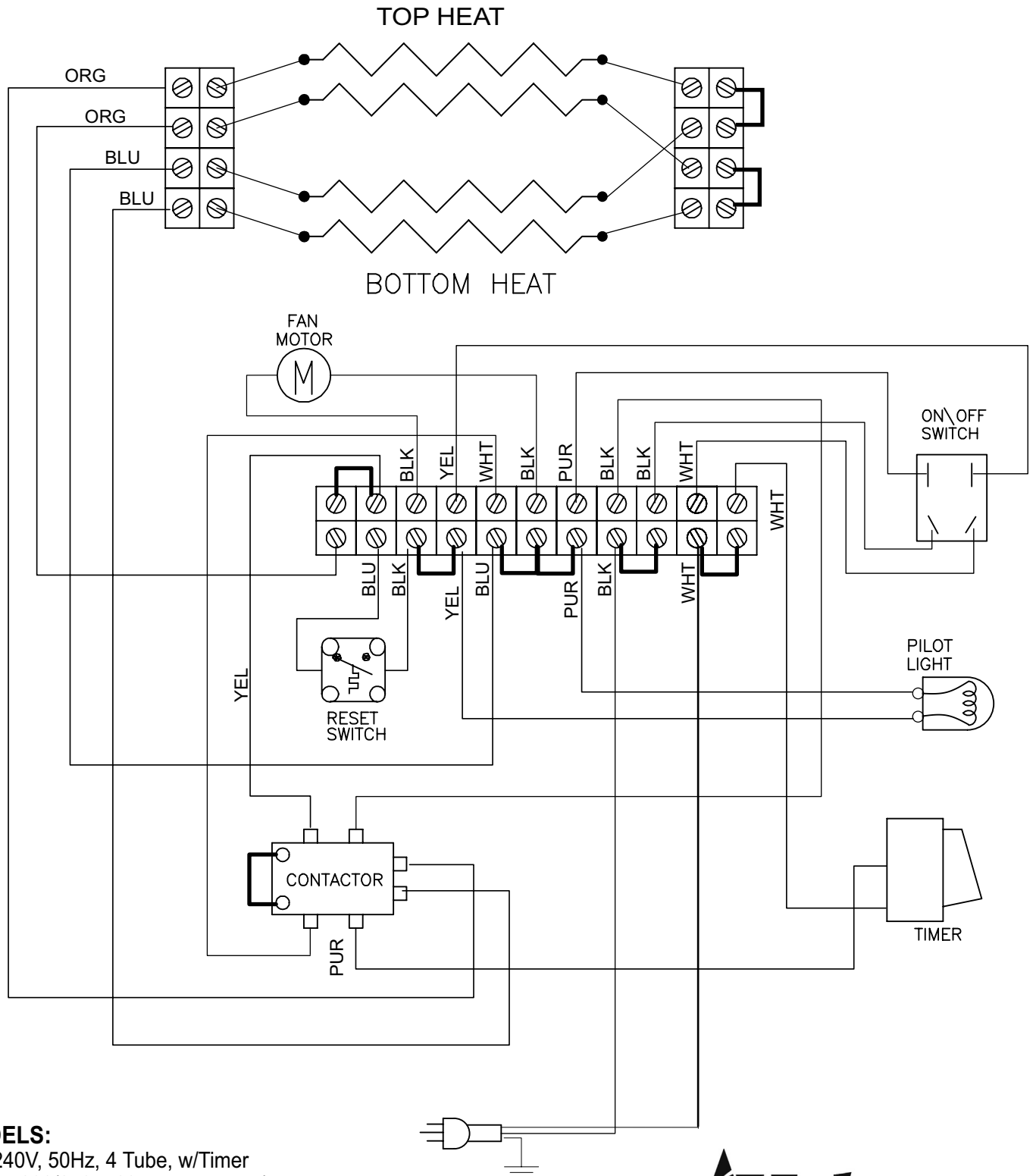

**MODELS:**

- FT1 240V, 50Hz, 4 Tube, w/Timer
- FT2BH 208/240V, 60Hz, 4 Tube, w/Timer
- FT2BH 220V, 50Hz, 4 Tube, w/Timer
- HH1, 220V, 60Hz, 4 Tube, w/Timer
- HH2, 208/220/240V, 60Hz, 4 Tube, w/Timer
- HH2, 220V, 50Hz, 4 Tube, w/Timer, CE



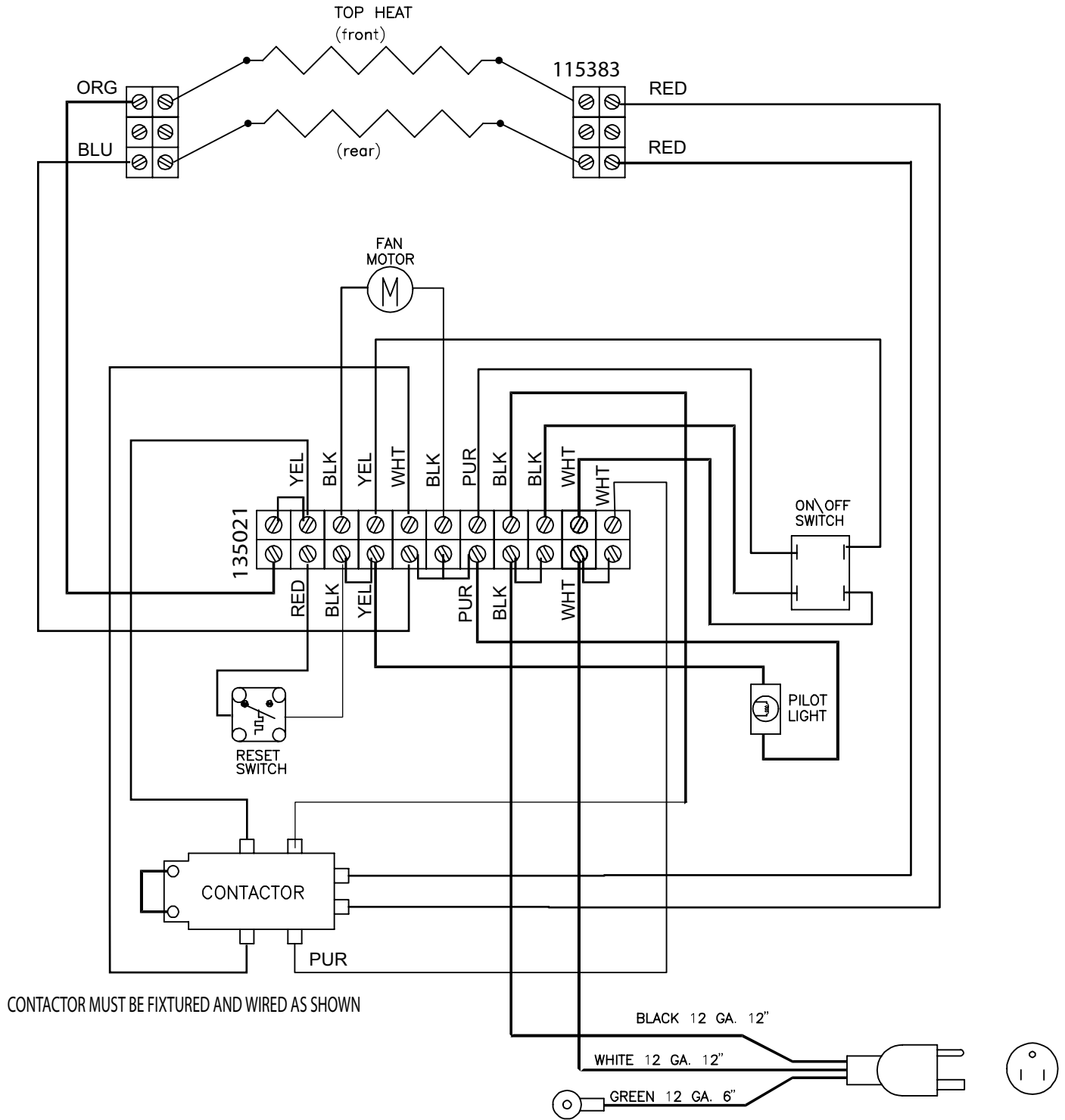

CONTACTOR MUST BE FIXTURED AND WIRED AS SHOWN

**MODELS:**  
 FT2NT, FT2WNT 120/, 60Hz, 2 Tube, NO TIMER



**STAR MANUFACTURING**

10 Sunnen Drive, St. Louis, MO 63143 U.S.A.

(800) 807-9054 (314) 781-2777

Parts & Service (800) 807-9054

[www.star-mfg.com](http://www.star-mfg.com)