RELEASE AGENT CAUTION

IF YOU FIND IT NECESSARY TO USE A RELEASE AGENT TO KEEP WAFFLES FROM STICKING, YOU SHOULD NEVER SPRAY DIRECTLY ONTO THE GRIDS. RELEASE AGENTS SHOULD ALWAYS BE BRUSHED ON BECAUSE SPRAYING WILL OVER-SATURATE THE GRIDS AND THE EXCESS HAS THE POSSIBILITY OF BUILDING UP INSIDE THE BAKER AND CAUSING DAMAGE TO THE BAKER. SPRAYING ALSO USES FAR TOO MUCH RELEASE AGENT AND IS MUCH MORE \$\$\$ THAN BRUSHING ON RELEASE AGENT. IF YOU ONLY HAVE A SPRAY TYPE RELEASE AGENT, THEN SPRAY INTO A CONTAINER AND THEN USE THE CONTENTS WITH A PASTRY BRUSH.

INSTALLATION: PLUG THE UNIT INTO A PROPER VOLTAGE AC ONLY WALL OUTLET. A THREE PRONG PLUG IS PROVIDED WITH THE UNIT. IF AN ADAPTER IS USED BE SURE A GOOD GROUND IS PROVIDED.

LOAD: THE RATED LOAD IS ON THE NAMEPLATE. THE LINE IN THE WALL OUTLET MUST BE HEAVY ENOUGH TO CARRY THIS LOAD, OR THE WAFFLE BAKER WILL BE SLOW IN PERFORMANCE.

TREATED GRIDS: THE GRIDS ARE TREATED WITH A SPECIAL PROCESS TO PREVENT STICKING BUT IT IS ADVISABLE TO GIVE THEM AN ADDITIONAL TREATMENT AS FOLLOWS:

TO BREAK IN GRIDS : TURN THE POWER ON AND WHEN THE LEFT-SIDE PILOT LIGHT GOES OUT THE UNIT IS UP TO PROPER TEMPERATURE. NOW TAKE A PASTRY BRUSH AND SPREAD VEGETABLE OIL, BUTTER, OR GRID RELEASE AGENT ON BOTH GRIDS. THE WAFFLE BAKER SHOULD THEN BE CLOSED FOR FIVE TO TEN MINUTES. THE BAKER IS NOW READY FOR USE. FOR PROPER RELEASE OF WAFFLES IT IS VERY IMPORTANT THAT THE BATTER CONTAINS THE PROPER AMOUNT OF SHORTENING.

MAKING WAFFLES

ONCE THE BAKER IS UP TO PROPER TEMPERATURE AND THE LEFT-SIDE PILOT LIGHT HAS GONE OFF AT LEAST ONE TIME, YOU CAN PROCEED AS FOLLOWS:

1. PRE-SET TIMER TO 3 1/2 TO 4 MINUTES FOR WB-280, (ALL TIMES DEPENDANT ON MIX TYPE AND TEMPERATURE).
2. POUR IN MIX. CLOSE THE TOP LID.
3. SET TIMER TO DESIRED TIME.
4. FOR NEXT WAFFLE REPEAT STEPS 2 THRU 4.

NOTE: DURING LONG SLACK PERIODS OF THE DAY, TURN OFF THE BAKER. DURING SHORT SLACK PERIODS, LEAVE GRIDS CLOSED. THE PILOT LIGHT WILL GO ON AND OFF WHILE IDLING, INDICATING THAT THE BAKER IS MAINTAINING A UNIFORM TEMPERATURE. A BELGIAN WAFFLE BATTER SHOULD BE THINNER THAN A REGULAR WAFFLE BATTER MIX. DO NOT STORE BATTER IN THE REFRIGERATOR AND EXPECT THE SAME SPEED IN BAKING. COLD BATTER WILL BE SLOWER IN BAKING. ON BAKERS THAT DO NOT HAVE TEFLON COATED GRIDS: IN ORDER TO REMOVE CARBON FROM THE GRIDS, DISCONNECT WAFFLE BAKER FROM CURRENT, PLACE CLOTH OVER THE BOTTOM GRID, SOAK WITH AMMONIA, CLOSE THE LID, AND LEAVE OVERNIGHT. THEN CLEAN OFF THE RESIDUE AND SEASON THE GRIDS AS DESCRIBED ABOVE. THIS SHOULD NOT BE DONE ON TEFLON-COATED GRIDS. IF CARBON BUILD-UP PERSISTS, YOU CAN ORDER A GRID CLEANING KIT WHICH WILL REMOVE EVEN THE HEAVIEST CARBON BUILD-UP.

CORD PLUG AND GROUNDING INSTRUCTIONS

FOR YOUR PROTECTION, THIS APPLIANCE IS EQUIPPED WITH A THREE CONDUCTOR CORD, HAVING A GROUNDING TYPE PLUG. IF YOU USE AN ADAPTOR BE SURE YOUR SYSTEM IS GROUNDED. THEN CONNECT THE GREEN WIRE OF THE ADAPTOR TO A MOUNTING SCREW OF THE RECEPTACLE. FOR UNGROUNDED SYSTEMS, ATTACH THE GREEN WIRE OF THE ADAPTOR TO A KNOWN PERMANENT GROUND.

WARRANTY

TOASTSWELL WARRANTS TO THE PURCHASER OF EACH NEW COMMERCIAL APPLIANCE THAT ANY PART WHICH PROVES TO BE DEFECTIVE IN MATERIAL OR WORKMANSHIP WITHIN ONE YEAR FROM THE DATE OF PURCHASE, WILL BE REPAIRED OR REPLACED FREE OF CHARGE. ANY DEFECT SHOULD BE BROUGHT TO THE ATTENTION OF THE TOASTSWELL COMPANY. THE TOASTSWELL COMPANY NEITHER ASSUMES NOR AUTHORIZES ANY PERSON TO ASSUME FOR IT ANY OTHER OBLIGATION OR LIABILITY IN CONNECTION WITH SUCH AN APPLIANCE. THIS WARRANTY DOES NOT APPLY, AND NO WARRANTY EITHER EXPRESSED OR IMPLIED SHALL BE APPLICABLE TO THE INSTALLATION OF APPLIANCE OR DAMAGE RESULTING FROM ACCIDENT, ALTERATION, MISUSE OR ABUSE. THIS WARRANTY DOES NOT INCLUDE THE CORD, PLUG, OR PLASTIC PARTS. WARRANTY DOES NOT COVER CONCEALED DAMAGE. FILE A CLAIM WITH THE CARRIER. DO NOT DESTROY THE ORIGINAL PACKAGE. BEFORE RETURNING, WRITE THE FACTORY FIRST, GIVING NATURE OF TROUBLE, SERIAL NUMBER, MODEL NUMBER AND VOLTAGE USED ON. WE MUST HAVE WARRANTY CARD WITHIN 15 DAYS, WHEN APPLIANCE IS FIRST CONNECTED AND USED, OTHERWISE WARRANTY IS VOIDED.

WARNING: GROUND FRAME OF APPLIANCE

TROUBLE-SHOOTING GUIDE AND PREVENTIVE MAINTENANCE

<u>TROUBLE</u>	<u>CAUSE</u>	<u>REMEDY</u>
BAKES WAFFLE TO SLOW	BATTER TO COLD TEMPERATURE SET TO LOW	ALLOW BATTER TO COME TO ROOM TEMP. ADJUST OR REPLACE THERMOSTAT. GRID TEMPERATURE SHOULD BE 380 TO 420 AFTER TWO CYCLES WITH GRIDS OPEN.
LIGHT DOES NOT GO ON OR UNIT DOES NOT HEAT	DEFECTIVE LIGHT OR ON-OFF SWITCH	REPLACE THE LIGHT OR SWITCH
WAFFLES STICK TO GRIDS	GRIDS NOT SEASONED PROPERLY MIX OR BATTER NOT A GOOD MIX.	SEASON GRIDS WITH OIL, BUTTER OR RELEASE AGENT. EXPERIMENT WITH A DIFFERENT MIX. ADD SOME SHORTING TO BATTER.
WAFFLE NOT COMPLETE	BATTER TO THICK OR TO COLD	ADD MORE LIQUID (SAME LIQUID AS ORIGINAL) TO THIN BATTER

PREVENTIVE MAINTENANCE

1. TO CLEAN BAKER SEE PROCEDURE ON FORM 125 B
2. IF YOU USE A COMMERCIAL CARBON REMOVER, MAKE SURE IT IS SAFE FOR ALUMINUM.
3. TO KEEP CARBON FROM BUILDING UP DO NOT USE A SPRAY GRID RELEASE BUT ONE THAT YOU CAN USE WITH A PASTRY BRUSH.

OPERATION INSTRUCTIONS

SUBJECT: OPERATING WAFFLE BAKER



NUMBER: WB-0007

MODEL: BELGIAN WAFFLE BAKER

DATE: 8/27/96



OPERATING WAFFLE BAKER:

1. Turn waffle baker on and allow grids to heat, indicator light will go off when unit is properly heated (HEATING TIME APPROXIMATELY 15 MINUTES).
2. Spray waffle release agent such as *Waffle Off*[™] onto cooking grids.
3. Pour approximately 6 oz. of waffle batter in the center of the bottom cooking grid.
4. Close top cooking grid and wait 10 seconds.
5. Rotate cooking grids clockwise  180° until locked against front support.
6. Set the bell timer to 3 1/2 minutes.
7. When bell timer rings/dings cooking is finished. Rotate cooking grids back counterclockwise  180° to original position and remove waffle.
8. For continuous use, repeat steps 2 - 7.

HELPFUL HINTS:

- During non-use periods, the grids should remain closed.
- If storing batter in the refrigerator - the batter may take longer to cook.

SEE SEPARATE CLEANING INSTRUCTIONS

WB-0004 CARE FOR NON-COATED WAFFLE GRIDS
WB-0005 CARE FOR NON-STICK COATED WAFFLE GRIDS

NOTE: *WAFFLE OFF*[™] (PART NO. 09-WB-2002) CAN BE PURCHASED THRU OUR CUSTOMER SERVICE DEPARTMENT (1-800-633-2608).



The Toastswell Company
640 Tower Grove Ave • St. Louis, Missouri 63110
(314) 371-2732 • FAX (314) 371-2700

12-WB-0025

 a Standex company

SUPPLEMENTAL INSTRUCTIONS

SUBJECT: CARE FOR NON-COATED WAFFLE GRID

NUMBER: WB-0004

MODEL:

DATE: 8/27/96



DO NOT IMMERSE APPLIANCE IN WATER!

NOTE: The waffle grids will darken with use and do not require cleaning unless there is carbon build-up.

CLEANING LIGHT CARBON BUILD-UP

1. Turn OFF and unplug the appliance.
2. After allowing appliance to cool completely, move it to a well ventilated area.
3. Soak a cloth with ammonia and place onto bottom waffle grid, making sure the total grid is covered.
4. Close top lid and place a plastic bag around the appliance. Seal the bag and let sit overnight.
5. Remove bag and sponge off carbon.
6. Rinse grids with hot water and allow to dry.

CLEANING NORMAL CARBON BUILD-UP

1. Turn OFF and unplug the appliance.
2. After allowing appliance to cool completely, sweep waffle grids with a Grid Cleaning Brush (Part No. 09-07-0036), available locally by calling parts distributor.
3. Scrub grids with a cleanser and scouring pad or steel wool, then rinse with hot water and allow to dry.

CLEANING HEAVY CARBON BUILD-UP

1. Turn OFF and unplug the appliance.
2. After allowing appliance to cool completely, clean waffle grids with Grid Cleaner "SOKOFF®" (Part No. 09-WB-2001), available locally by calling parts distributor.

NOTE: ALWAYS FOLLOW MANUFACTURER'S INSTRUCTIONS ON GRID CLEANER CONTAINER.

3. Rinse grids with hot water and allow to dry.
4. After cleaning, coat grids with a thin layer of cooking oil.



The Toastswell Company

640 Tower Grove Ave • St. Louis, Missouri 63110
(314) 371-2732 • FAX (314) 371-2700

12-WB-0051

 a Standex company

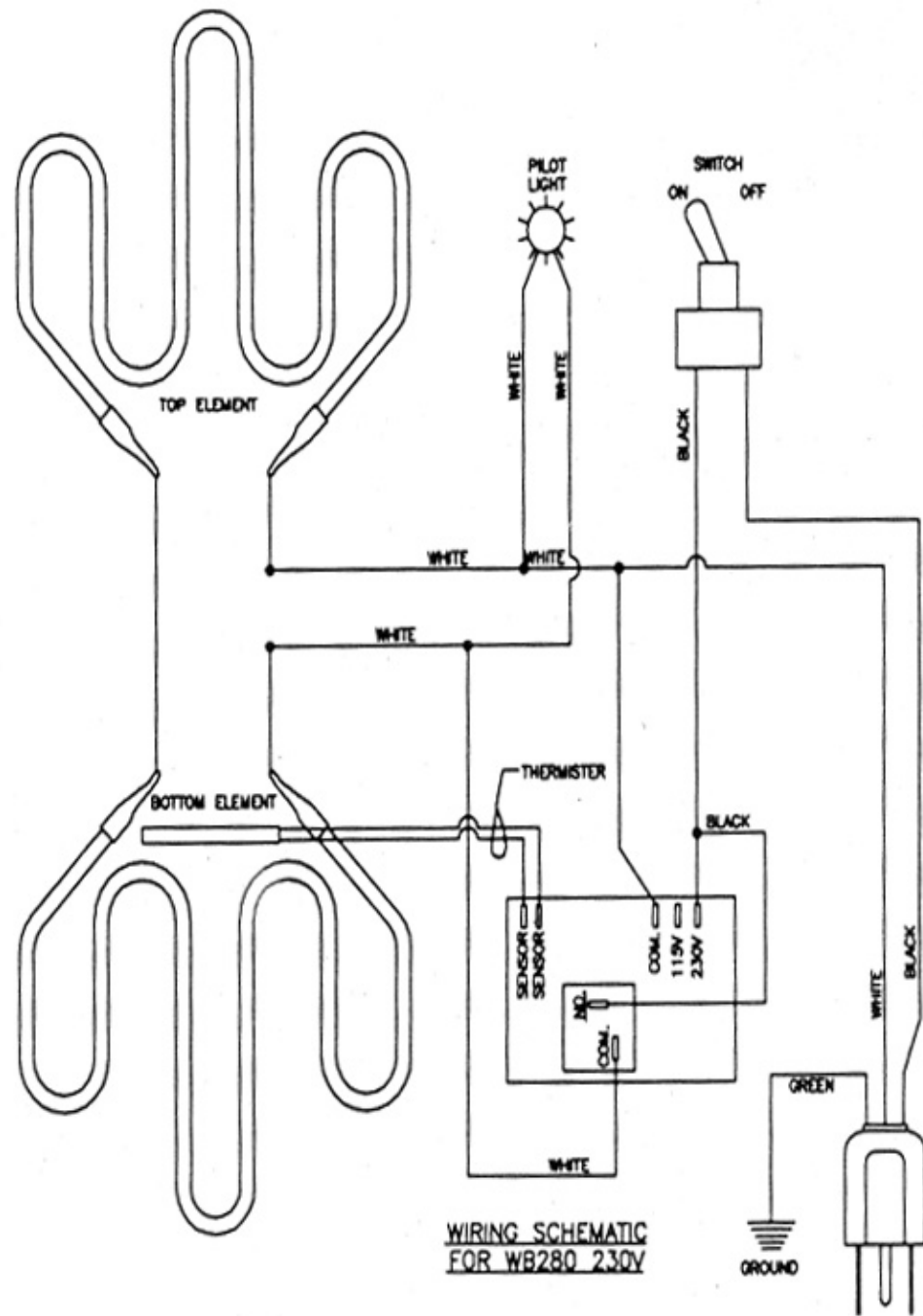
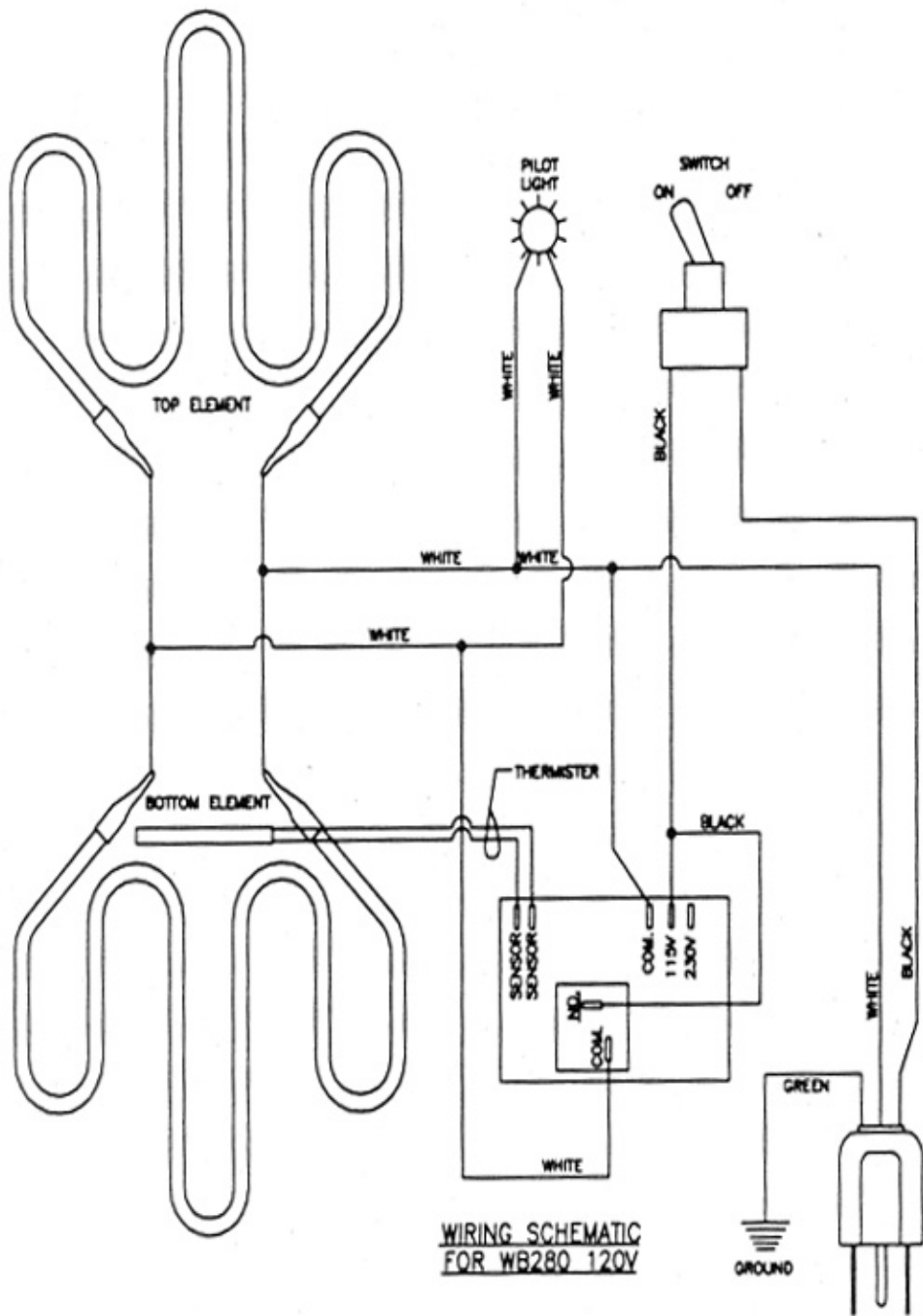

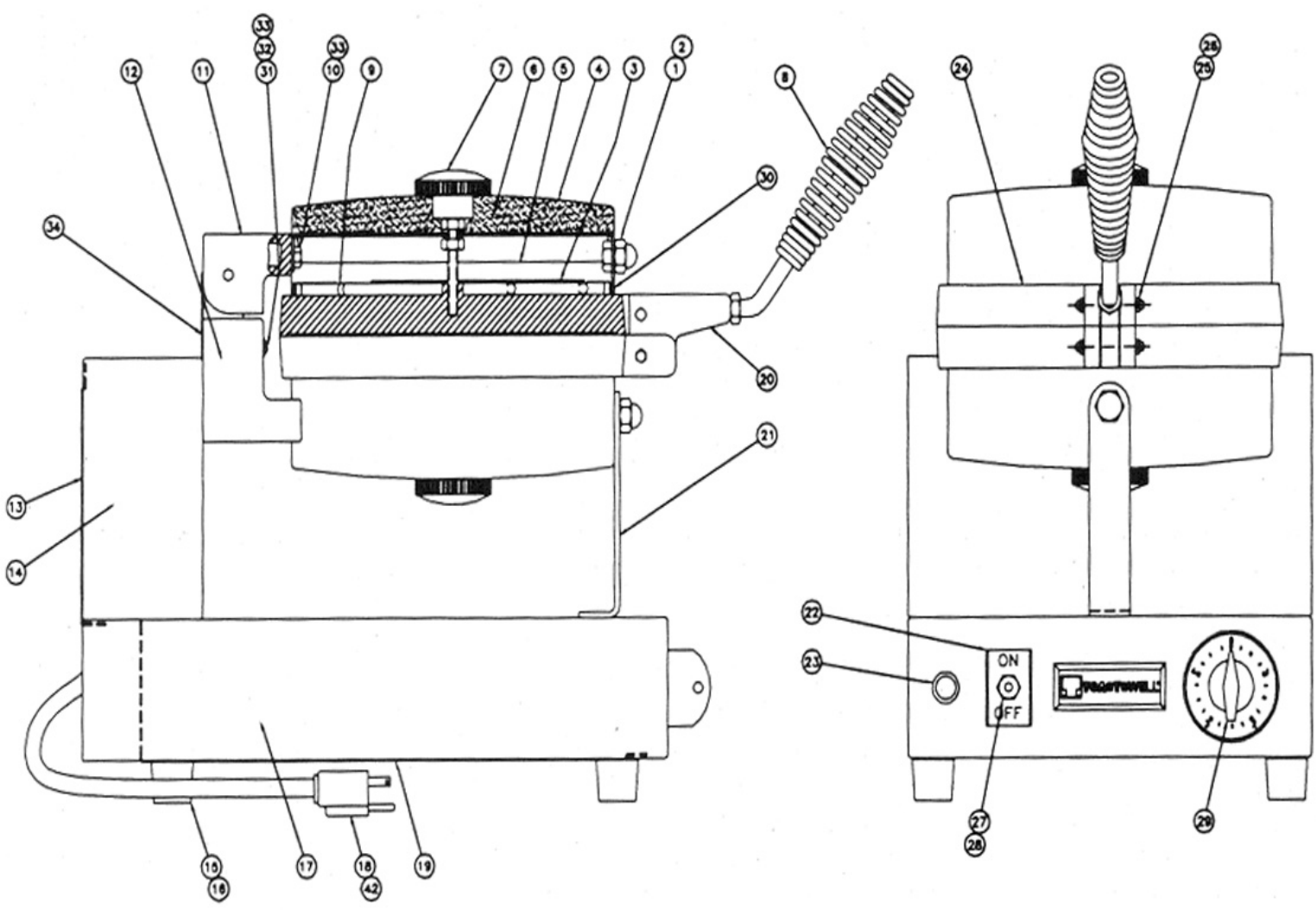

BELGIAN WAFFLE BAKERS

MODEL : WB280-L & 280-H

Key Number	Part Number	Number Per Unit	Description
1	2C-08-07-0064	1	NUT ACCORN HEX 3/8-24
2	2C-08-07-0041	1	BOLT 3/8 -24 X 1/2 HEX
3	B9-30-WB-0154	1	ELEMENT MOUNT: TOP INCLUDES THE FOLLOWING:
	B9-53-WB-0093	1	MOUNT ASSEMBLY: ELEMENT
	B9-04-WB-0136	2	SPACER: ELEMENT MOUNT
	B9-30-WB-0155	1	ELEMENT MOUNT ASSEMBLY: BOTTOM INCLUDES THE FOLLOWING:
	B9-50-WB-0002	1	THERMISTER MOUNT: ELEMENT
	B9-04-WB-0136	2	SPACER: ELEMENT MOUNT
4	B9-04-WB-0134	2	CUP
5	B9-04-WB-0136	2	SUPPORT: INNERCUP
6	B9-04-WB-0036	2	CERALWOOL
7	B9-50-WB-0015	2	LOCK KNOB ASSEMBLY
	2C-Z1674	1	ROD: 1/4-20 THREADED
	2R-09-WB-0015	1	KNOB: BLACK PHENOLIC
8	B9-40-WB-0067	1	HANDLE ASSEMBLY INCLUDES THE FOLLOWING:
	B9-70-WB-0067	1	ROD: HANDLE
	B9-70-WB-0009	1	HANDLE: SPRING
9	2N-05-WB-0014	2	ELEMENT: 650W
11	B9-51-WB-0121	1	HINGE: TOP
12	B9-01-WB-0010	1	HINGE: BOTTOM
13	B9-04-WB-0128	1	COVER: BACK
14	B9-04-WB-0125	1	FRAME: BACK
15	2A-09-07-0009	4	FOOT NEOPRENE
16			SCREW
17	B9-04-WB-0126	1	FRAME: BOTTOM
18	2E-05-07-0005	1	CORDSET: 14/3 NEMA 5-15P 120V
	2E-05-07-0052	1	CORDSET: 14/3 NEMA 6-15P 208/230V
19	B9-04-WB-0127	1	COVER: BOTTOM
20	B9-70-WB-0001	1	LOCK: HANDLE
21	B9-04-WB-0133	1	SUPPORT: CUP
22	Z1-04-07-0343	1	GUARD: SWITCH
23	2J-05-07-0006	1	PILOT LIGHT: 120V
	2J-05-07-0010	1	PILOT LIGHT: 208/230V
24	B9-30-WB-0044	2	GRID: TOP AND BOTTOM
25	B9-70-WB-0132	2	PIN: LOCK AND HANDLE
26	2C-08-07-0040	4	NUT 1/4-20 ACHD STL NP
27	2E-05-07-0013	1	SWITCH: TOGGLE
28	2I-05-07-0013	1	BOOT: SWITCH
29	B9-30-WB-0049	1	BELL TIMER ASSEMBLY INCLUDES THE FOLLOWING
	2C-08-WB-0008	1	NUT: TIMER BELL
	2C-09-WB-0005	1	BEZEL: TIMER
	2R-09-WB-0006	1	KNOB: BELL
	2R-09-WB-0007	1	TIMER BELL
30	2I-07-WB-0002	2	SEAL: O-RING
31	B9-04-WB-0037	1	COVER: HINGE BOTTOM
	B9-04-WB-0088	1	COVER: HINGE TOP
32	B9-04-WB-0046	1	CLAMP: SUPPORT WIRE
33	Z1-09-07-0004	2	COVER: WIRE SPRING
ITEMS NOT SHOWN:			
	2E-05-WB-0006	1	Zytron Control
	2E-70-WB-0047	1	THERMISTOR
	2C-09-07-0011	2	COVER CLIP: ADHESIVE BACKED .375
	2C-05-07-0004	6	PIGTAIL: WIRE CONNECTOR
	2M-12-WB-0013	1	PARTS LIST & DRAWING
	2K-05-07-0017	1	BUSHING, CORDSET

**IMPORTANT: WHEN ORDERING, SPECIFY VOLTAGE OR TYPE GAS DESIRED
INCLUDE MODEL AND SERIAL NUMBER**

PAGE 1
OF 1

Some items are included for illustrative purposes only and in certain instances may not be available.



Star Manufacturing International, Inc.