

ENCORE[®]
SERIES

INSTALLATION AND OPERATING MANUAL

PN 99739

SERVICE GELATO DISPLAY CASE - LOW TEMPERATURE

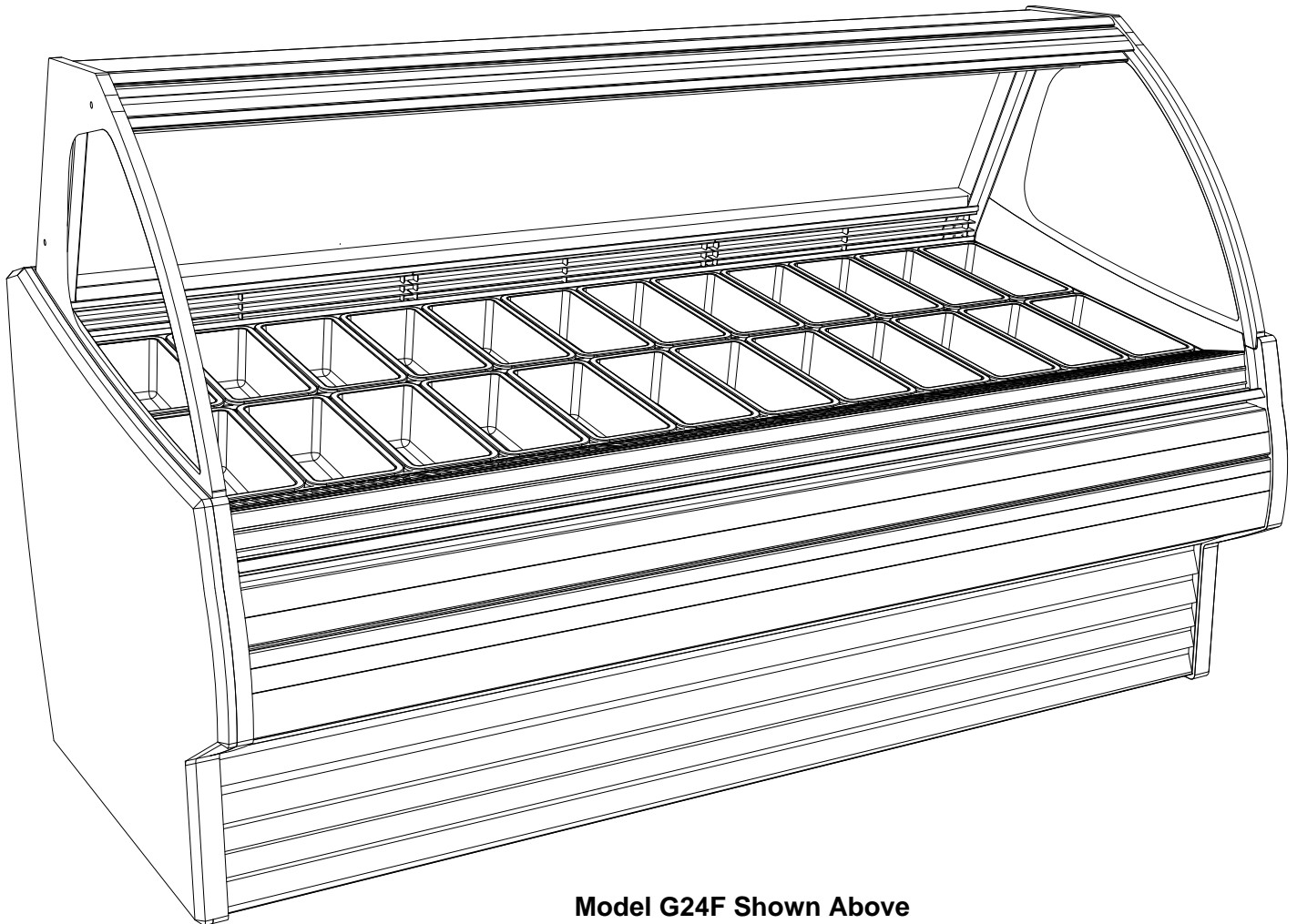

**Model G24F Shown Above
(Your Model May Slightly Vary)**

Model G12F / G12F.4759 / G12F.5150.....47 1/2" L* x 43 3/8" D x 53 3/4" H**
Model G18F / G18F.4888A.....67 1/2" L* x 43 3/8" D x 53 3/4" H**
Model G24F.....84 1/2" L* x 43 3/8" D x 53 3/4" H**

**Includes 2" End Panels*

***Includes Levelers at 1 1/4" Below Base Frame*



Structural

Concepts

888 E. Porter Road · Muskegon, MI 49441 Phone: 231.798.8888 Fax: 231.798.4960 www.structuralconcepts.com

TABLE OF CONTENTS

OVERVIEW / TYPE / COMPLIANCE / WARNINGS / PRECAUTIONS / WIRING / PLUGS	3-4
INSTALLATION	5
START-UP / OPERATING / MAINTENANCE / DRAIN SYSTEMS SECTION	6
START-UP AND OPERATION	7
MAINTENANCE FUNDAMENTALS	8
MODEL G12F DRAIN SYSTEM (Self-Contained Units With Optional Evaporator Pan Only)	9
MODEL G18F DRAIN SYSTEM (Self-Contained Units With Optional Evaporator Pan Only)	10
MODEL G12F DRAIN SYSTEM (CDR.4759 / Non-Standard Self-Contained Unit - No Evap. Pan)	11
MODEL G24F DRAIN SYSTEM (Self-Contained Units With Optional Evaporator Pan Only)	12
STORE EMPLOYEES' SECTION ONLY	13
CLEANING SCHEDULE (TO BE PERFORMED BY STORE PERSONNEL)	14
DIPWELL™ CLEANING (TO BE PERFORMED BY STORE PERSONNEL)	15
WEEKLY CLEANING (TO BE PERFORMED BY STORE PERSONNEL)	16-19
TROUBLESHOOTING (TO BE PERFORMED BY STORE PERSONNEL)	20
TRAINED SERVICE PROVIDERS' SECTION ONLY	21
PREVENTIVE MAINTENANCE (TO BE PERFORMED BY TRAINED SERVICE PROVIDERS ONLY)	22-25
TROUBLESHOOTING (TO BE PERFORMED BY TRAINED SERVICE PROVIDERS ONLY)	26
GENERAL TECHNICAL INFORMATION (SERIAL LABEL INFO / TEMPERATURE CONTROLLER INFORMATION / TECHNICAL SERVICE INFORMATION, ETC.)	27
SERIAL LABEL LOCATION & INFORMATION LISTED / TECH INFO & SERVICE	28
CAREL® TEMPERATURE CONTROLLER	29-31
TECHNICAL SERVICE CONTACT INFORMATION & WARRANTY INFORMATION	32

OVERVIEW

- The Structural Concepts® Glass Front, Freezer Service Gelato Display Case is designed to merchandise gelato and/or soft ice cream into cones, containers or dishes.
- This case is designed to maintain product at temperatures of -2° F (-19 °C).
- Product must be pre-chilled to -2 °F (-19 °C) before placing in merchandiser.
- Cases should be installed and operated according to this operating manual's instructions to insure proper performance.
- Improper use will void warranty.

- For Type 2 Conditions: ambient conditions are to be at 60% maximum humidity and maximum temperatures of 80 °F [27 °C].
- If unsure if unit is designed for Type 1 or 2, see tag next to serial label. See **SERIAL LABEL LOCATION & INFORMATION LISTED / TECH INFO & SERVICE** section in this manual for sample serial labels.

CASE TYPE

This unit is designed for the display of products in ambient store conditions where temperatures and humidity are maintained within a specific range.

- For Type 1 Conditions (most cases): ambient conditions are to be at 55% maximum humidity and maximum temperatures of 75 °F [24 °C].

COMPLIANCE

- Performance issues when in violation of applicable NEC, federal, state and local electrical and plumbing codes are not covered by warranty.
- See below compliance guideline.

WARNINGS

- This sheet contains important warnings to prevent injury or death.
- Please read carefully!

PRECAUTIONS, CORD/PLUG MAINTENANCE & WIRING DIAGRAM INFORMATION

- See next page for **PRECAUTIONS, CORD/PLUG MAINTENANCE** and **WIRING DIAGRAM** information.



**ATTENTION
INSTALLER**

COMPLIANCE
This equipment **MUST** be installed in compliance with all applicable NEC, federal, state and local electrical and plumbing codes.

WARNING
ELECTRICAL HAZARD

WARNING
Risk of electric shock. Disconnect power before servicing unit. **CAUTION!** More than one source of electrical supply is employed with units that have separate circuits. **Disconnect ALL ELECTRICAL SOURCES before servicing.**

WARNING
KEEP HANDS CLEAR

WARNING
Hazardous moving parts. Do not operate unit with covers removed. Fan blades may be exposed when deck panel is removed. **Disconnect power before removing deck panel.**

WARNING
HOT SURFACE

WARNING
Condenser Pan is Hot!
Disconnect and allow to cool before cleaning or removing from case.

PRECAUTIONS

- This sheet contains important precautions to prevent damage to unit or merchandise.
- Please read carefully!
- See previous page for specifics on **OVERVIEW**, **TYPE**, **COMPLIANCE** and **WARNINGS**.

WIRING DIAGRAM

- Each case has its own wiring diagram folded and in its own packet.
- Wiring diagram placement may vary; it may be placed near ballast box, field wiring box, raceway cover, or other related location.

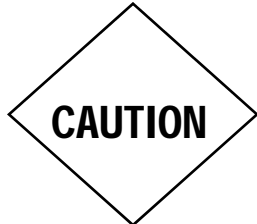

CAUTION! LAMP REPLACEMENT GUIDELINES
 Fluorescent lamps have been treated to resist breakage and must be replaced with similarly treated lamps.
 LED lamps reflect specific size, shape and overall design. Any replacements must meet factory specifications.



CAUTION! GFCI BREAKER USE REQUIREMENT
 If N.E.C. (National Electric Code) or your local code requires GFCI (Ground Fault Circuit Interrupter) protection, you **MUST** use a GFCI breaker in lieu of a GFCI receptacle.



CAUTION! POWER CORD AND PLUG MAINTENANCE
 Risk of electric shock. If cord or plug becomes damaged, replace only with cord and plug of same type.



CAUTION! ADVERSE CONDITIONS / SPACING ISSUES

- Performance issues caused by adverse conditions are **NOT** warranted.
- End panels must be tightly joined or kept at least **6-inches** away from any structure to prevent condensation.
- Unit must be kept at least **15-feet** from exterior doors, overhead HVAC vents or any air curtain disruption to maintain proper temperatures.
- Unit must not be exposed to direct sunlight or any heat source (ovens, fryers, etc.).
- Tile floors, low ceilings or small rooms increase noise level. Whisper Cool compressor blankets or remote units resolve noise level issues.
- Keep at least **8-inch** clearance above unit for air discharge (self-contained units only).



CAUTION! CHECK EVAPORATOR PAN POSITION AND PLUG
 Water on flooring can cause extensive damage!
 Before powering up unit, check the following:

- Evaporator pan **MUST BE** positioned directly under condensate drain.
- Evaporator pan plug **MUST BE** securely plugged into receptacle.

INSTALLATION

Installation: Units shown may not depict an exact representation of your particular unit being installed.

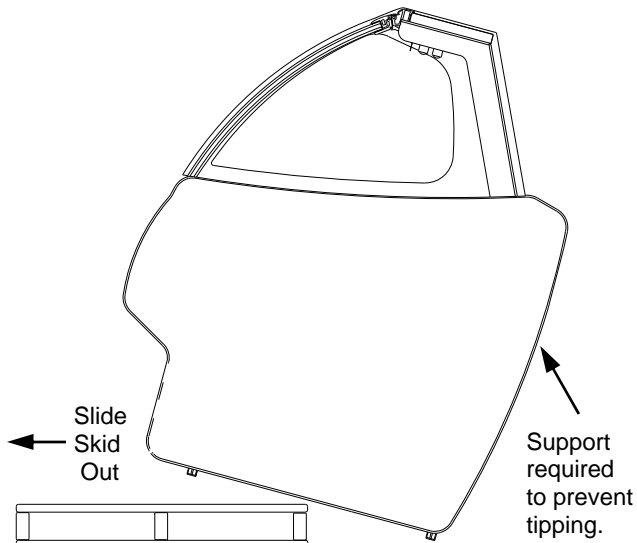

1. Remove Unit From Skid

Caution: case must always remain supported or center of gravity will allow case to fall. Slide unit to rear of skid and tip backward off skid.

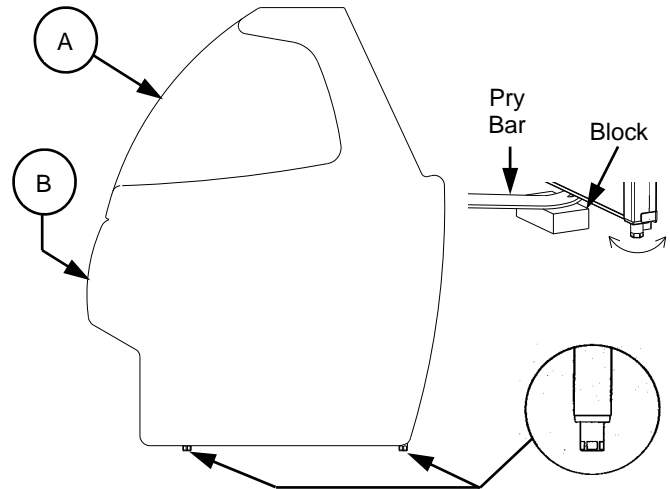

2. Case Aligning, Adjusting and Sealing

- For Service Glass to align properly, case must be level and plumb. Adjust feet accordingly (see illustration above).
- **Caution! These units MUST BE sealed to the floor to maintain conformance to NSF® equipment mounting standards.**
- Align multiple units (as shown above with balloons A and B).

3. Remote Electrical Connections:

Model G24F: Field wiring hook-up / electrical access locations are shown in the illustration below.

- 220V Single Phase Leads or Cord with Nema Plugs provided.
- See *SERIAL LABEL LOCATION & INFORMATION LISTED / TECH INFO & SERVICE* for more detailed information.
- **Model G12F:** Field wiring hook-up / electrical access locations are at opposite end than that shown below.

Model G24F: Field Wiring Hookup into Electrical Box **Model G12F:** Field Wiring Hookup is at opposite end.

Wireway through Rear Grille

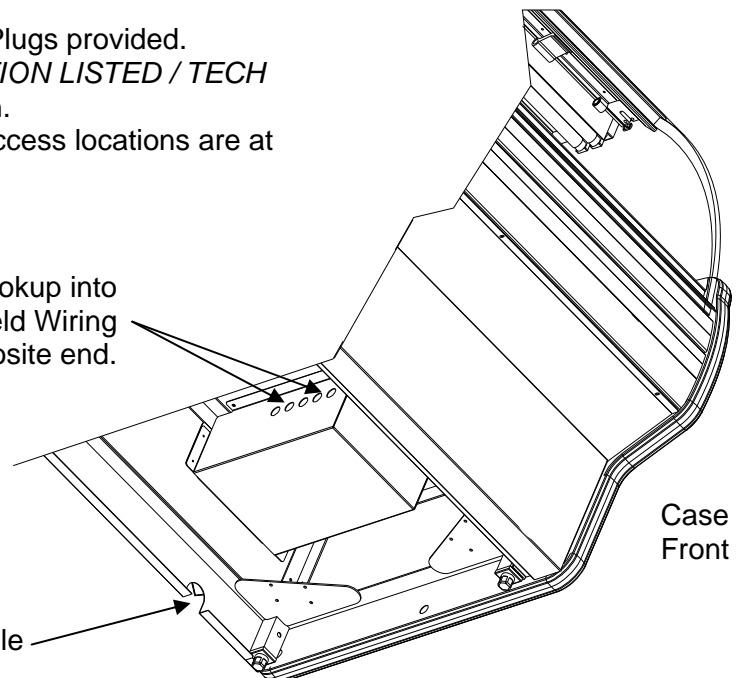

**START-UP /
OPERATING /
MAINTENANCE /
DRAIN SYSTEMS**

START-UP AND OPERATION

Merchandise Start-Up

- **Self-Contained:** Main Power switch is located at case rear, lower left. See illustration at lower right and lower left.
- **Remote Units:** Case is hard-wired. When power is supplied, case will power-up.
- **Lights:** Turn on the lights. Whether Remote or Self-Contained, light switch is located on inside of case at top left, from case rear. See illustration at top right.
- **Light Warm-up:** All lights should come on at the same time. First time lighting may require a short warm up period for the bulbs. Slightly dim or a flickering of new bulbs is normal.
- **Merchandising:** *Please allow unit to run empty for at least 1 1/2 hrs (90 minutes) before merchandising.*

Raise the Curved Glass

- To raise the curved glass, grasp the lift handle extrusion on the bottom edge of the door and lift up. See illustration below-right.
- **Caution:** Carefully return curved glass to original position.

Removing (Optional) Rear Glass Doors

- Move rear doors toward the case center.
- Individually lift each door up toward top of case and pivot bottom of the door out.
- **Caution:** Gently set doors down to avoid marring, scratching or breakage.

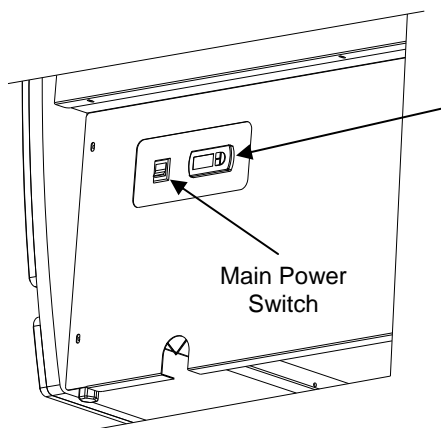

Temperature Controller Location:

G24F: At Left Side of Case Rear
(as shown above)

G12F: At Right Side of Case Rear

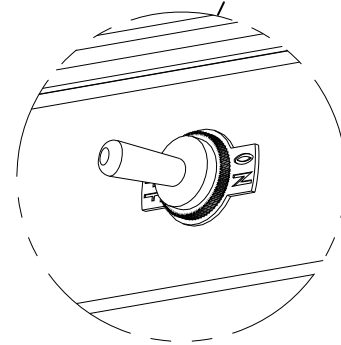
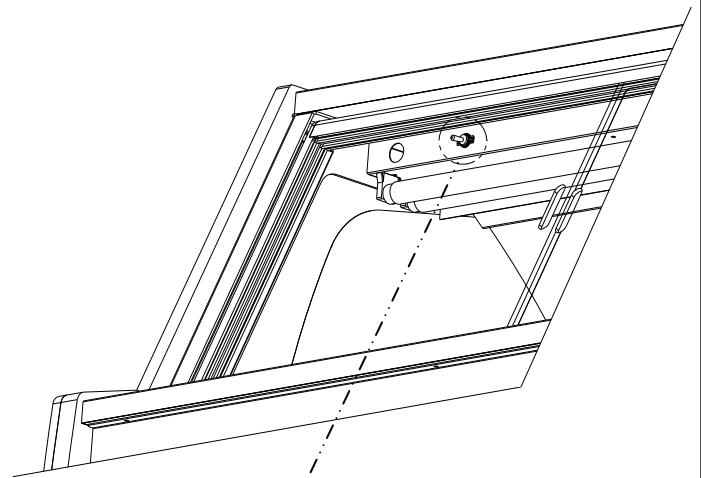

View of Curved Glass being raised

View of Rear Door being lifted up, pivoted out and away from case

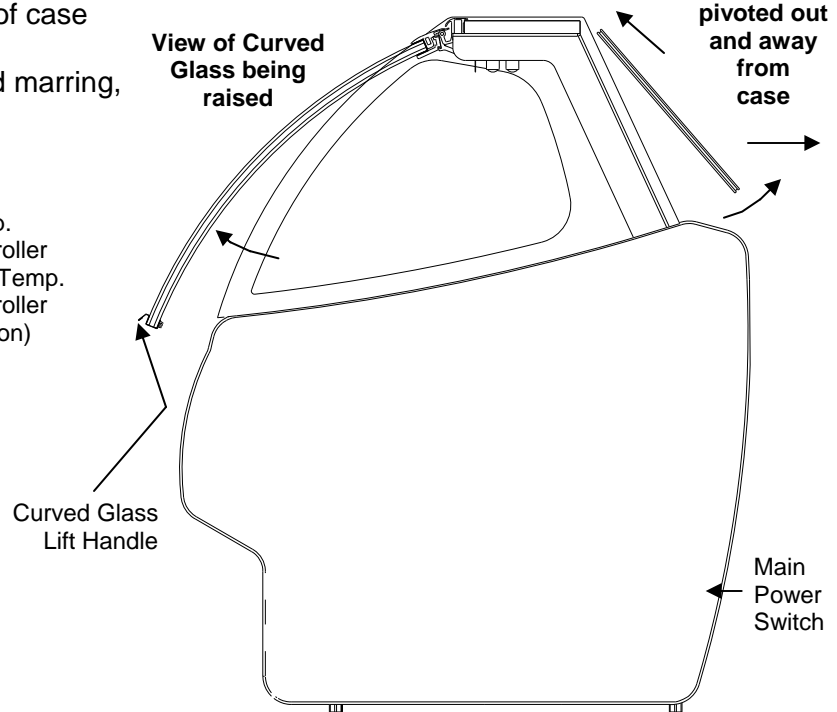

Light Fixtures

Warning! Disconnect power before providing maintenance and service to unit.

Caution: Lamps have been treated to resist breakage and must be replaced with similarly treated lamps.

Light fixtures are to be located on underside of shelf assembly, at the top inside of case, and lower front nose of case. See next page for light fixture locations.

Removal of lamp:

- Rotate lamp (1/4-turn) either direction to disengage (upper or lower) pins/contacts from lamp-mounting sockets.
- Remove bulb by applying even pressure from back side at the bulb ends and pulling the remaining contact from sockets.

Installation of lamp:

- Align pins with slot.
- Insert pins into socket by rotating the bulb 1/4-turn to secure either the (upper or lower) pin contacts into the sockets.
- Rotate remaining bulb contacts (1/4-turn) into remaining lamp mounting socket contacts.

Optional Clean Sweep Condensing Coil

- Clean sweep Condensing Coil (photo below) is accessible by removing rear grille.
- See *Preventive Maintenance (To Be Performed By Trained Service Provider)* for cleaning instructions.
- Photo below is after rear grille has been removed case

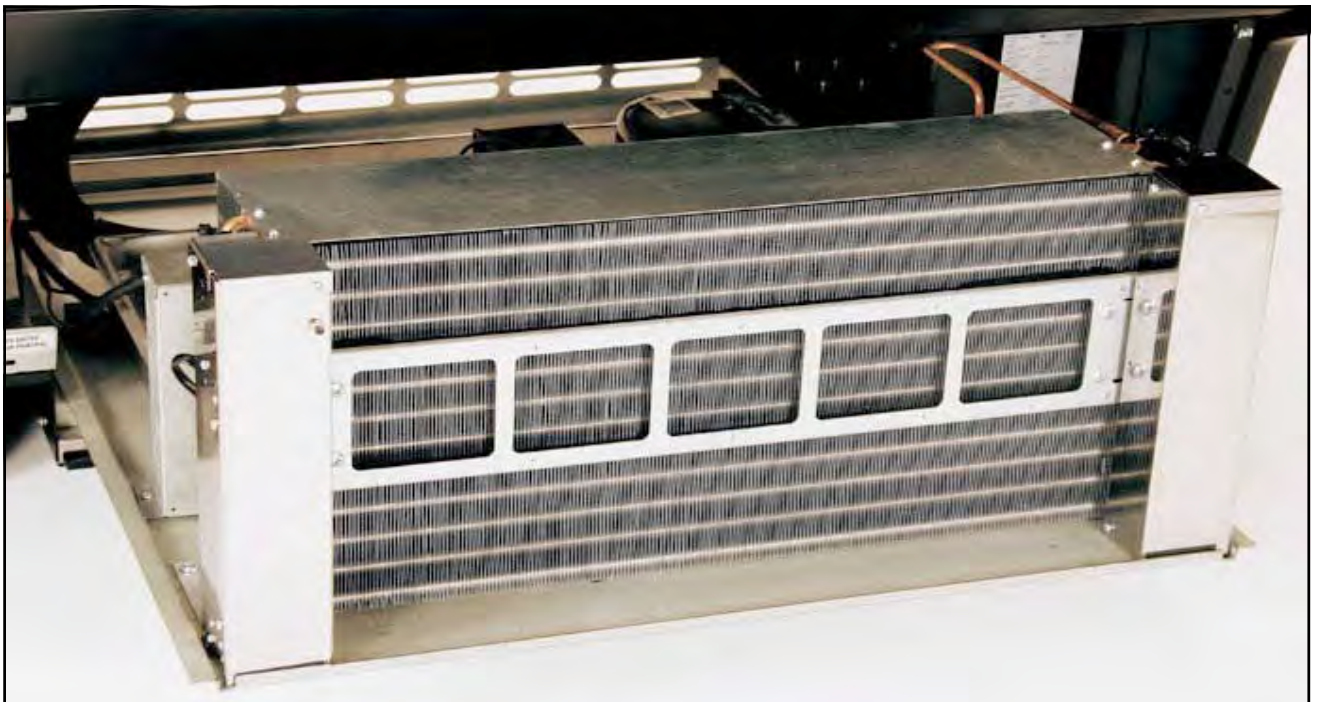

MODEL G12F DRAIN SYSTEM (Standard Self-Contained Units With Optional Evaporator Pan Only)

Self-Contained Units have Drain Systems that allow thorough defrost and interior cleaning.

- Default Drain Valve setup (from manufacturer) is with Internal Evaporator Pan being utilized.

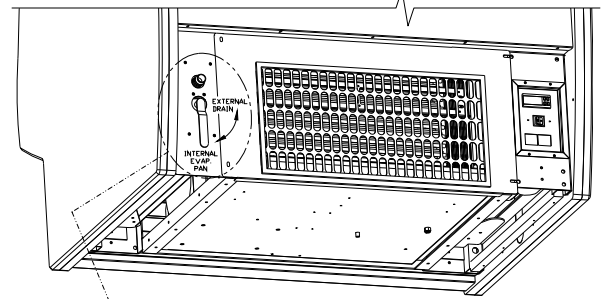
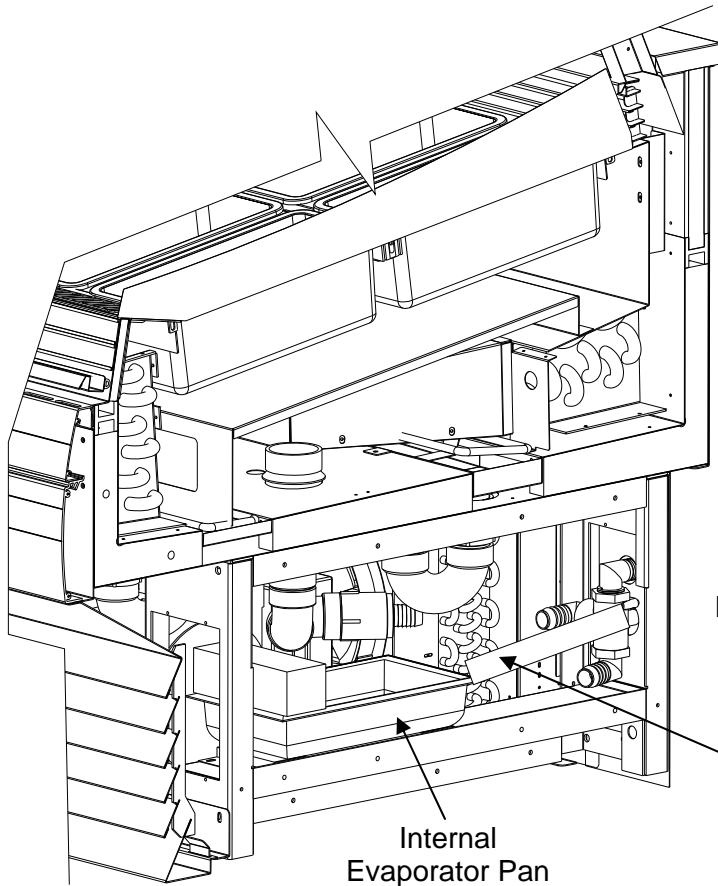

Model G12F View of Case Rear (Your Model May Vary)

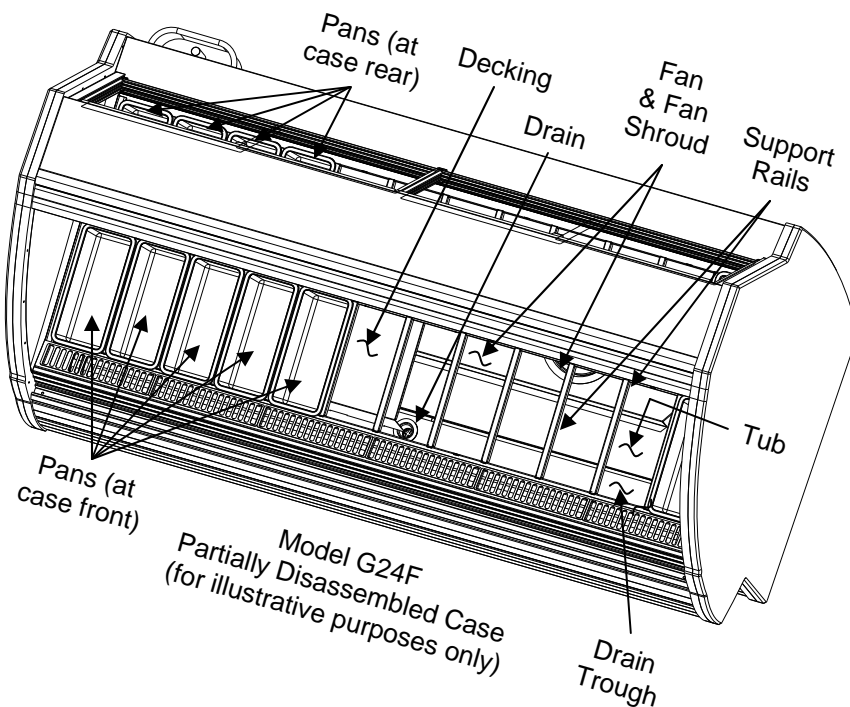
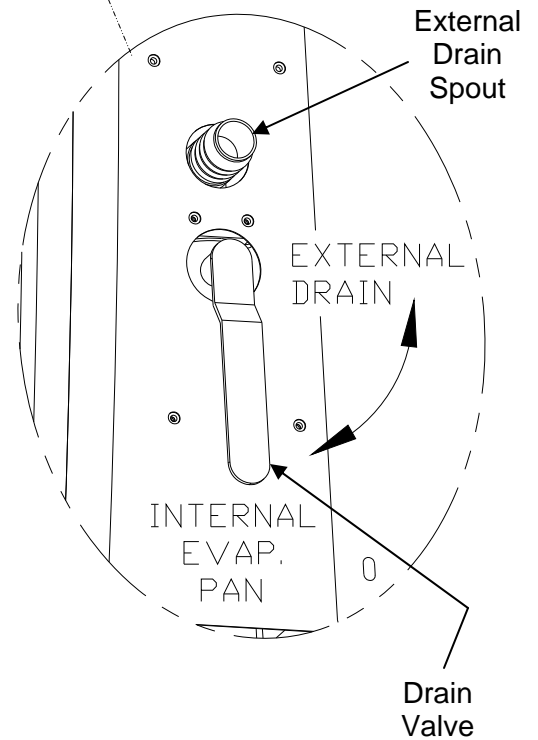

Note : Model and options chosen may affect location of valves, drains, controller, electrical box location, or number of pans shown in these illustrations.

G12F DRAIN SYSTEM (CDR5150 / Non-Standard Self-Contained Unit - No Evaporator Pan)

Self-contained are designed to allow thorough defrost and interior cleaning.

- Default system of this unit (from manufacturer) is **WITHOUT** Internal Evaporator Pan being utilized.
- See **DIPWELL™ OPERATION AND REMOVAL FOR CLEANING** for Dipwell™ illustration.

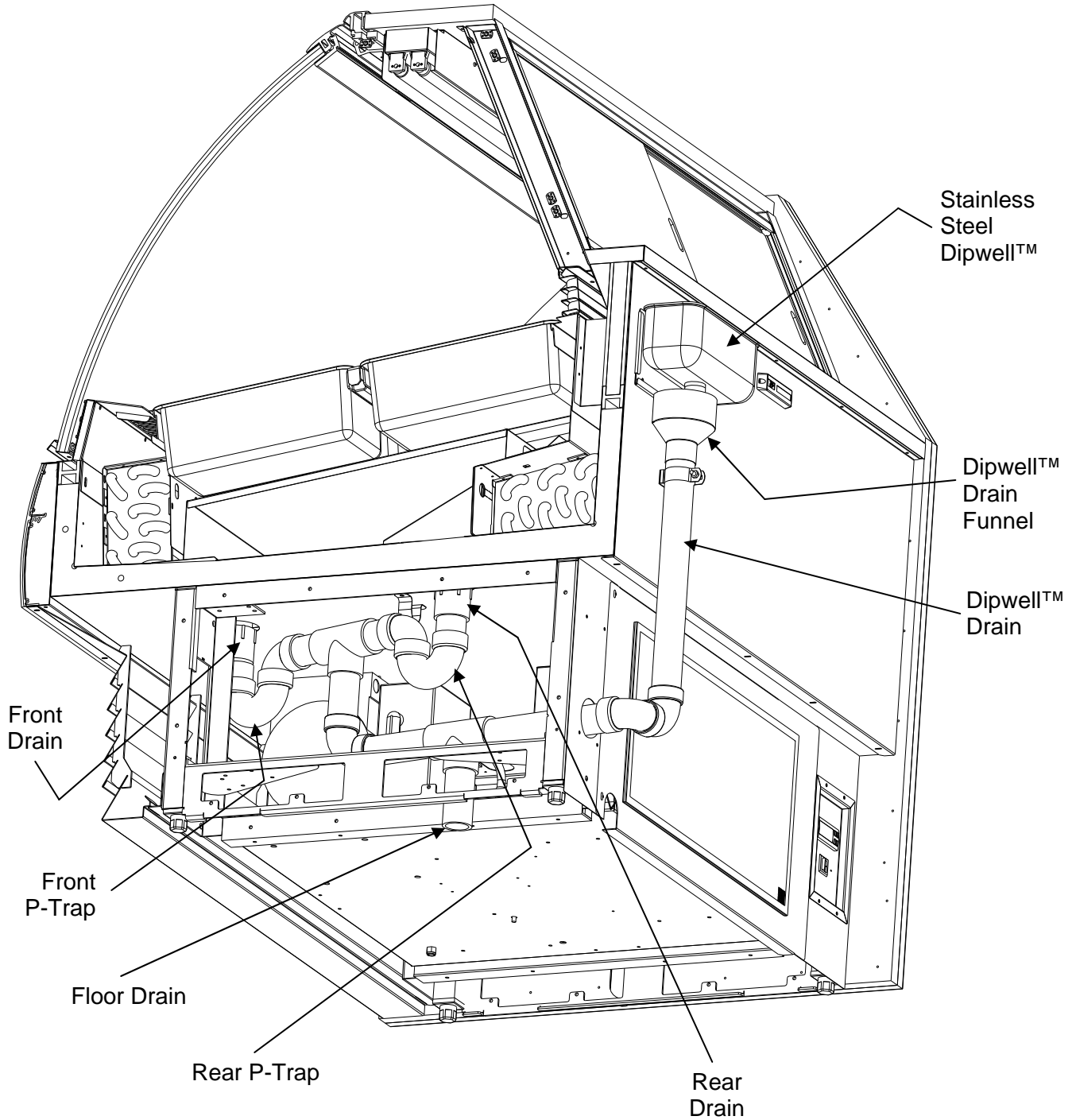

Note : Model and options chosen may affect location of valves, drains, controller, electrical box location, or number of pans shown in these illustrations.

MODEL G18F DRAIN SYSTEM (Self-Contained Units With Optional Evaporator Pan Only)

Self-contained units have drain systems that allow thorough defrost and interior cleaning.
 > Default drain valve setup (from manufacturer) is with internal evaporator pan being utilized.

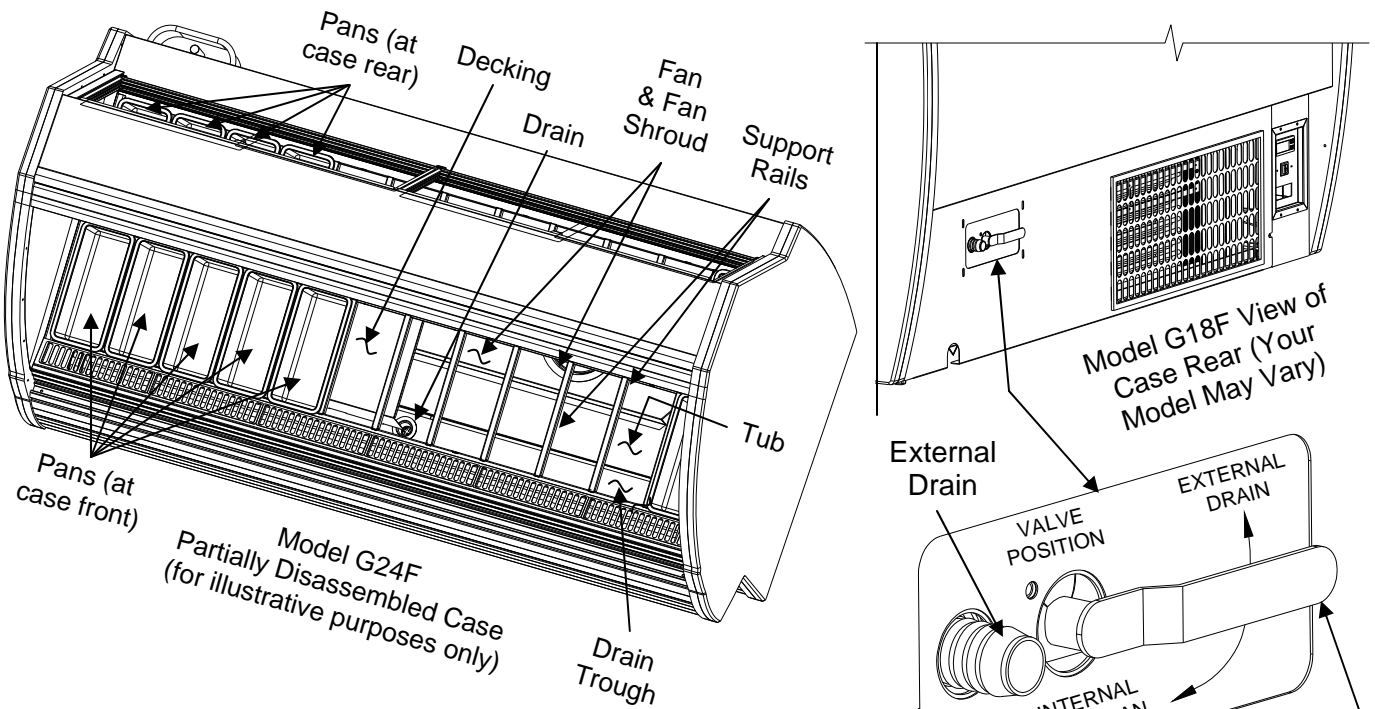

Note : Model and options chosen may affect location of valves, drains, controller, electrical box location, or number of pans shown in these illustrations.

Model G18F Evaporator Pan Setup Shown At Right

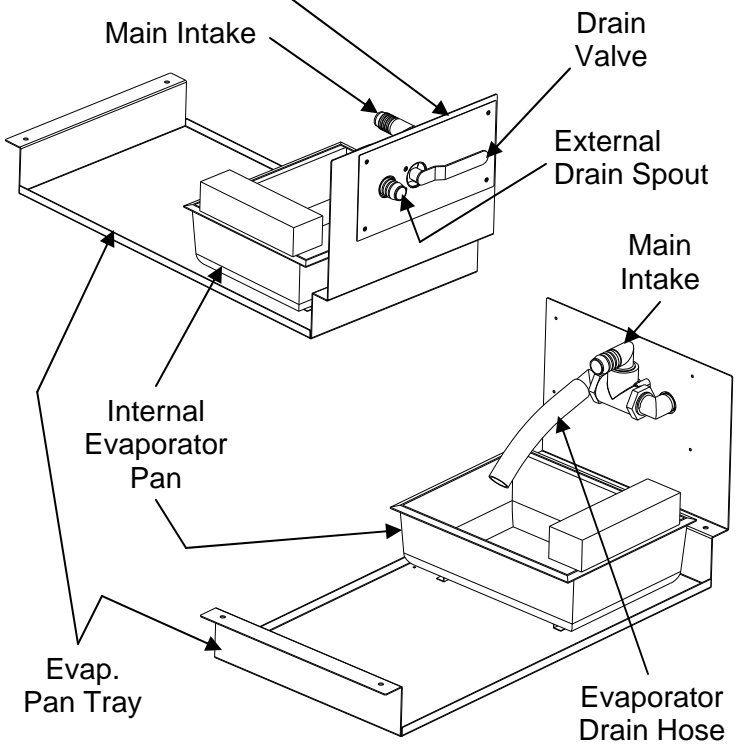

MODEL G24F DRAIN SYSTEM (Self-Contained Units With Optional Evaporator Pan Only)

Self-Contained Units have Drain Systems that allow thorough defrost and interior cleaning.

- Default Drain Valve setup (from manufacturer) is with Internal Evaporator Pan being utilized.

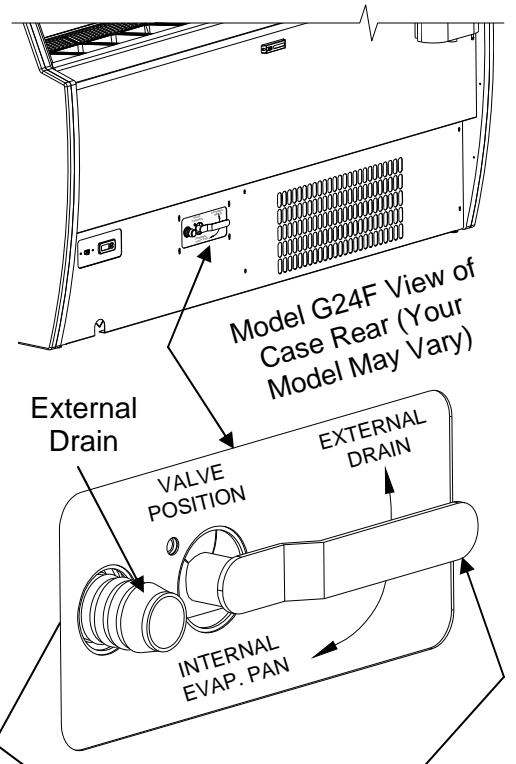
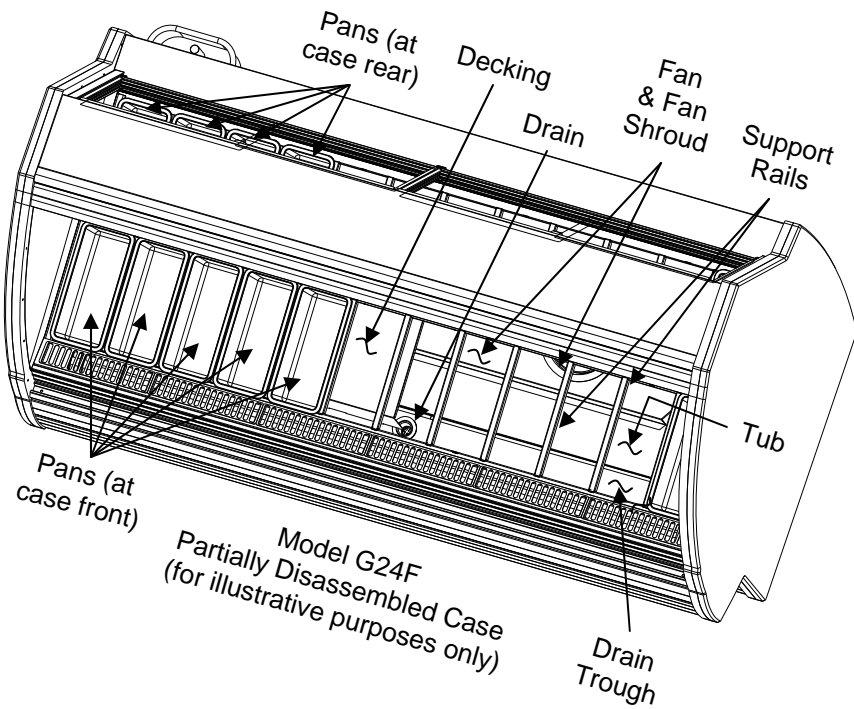

Note : Model and options chosen may affect location of valves, drains, controller, electrical box location, or number of pans shown in these illustrations.

Model G24F Evaporator Pan Setup Shown At Right

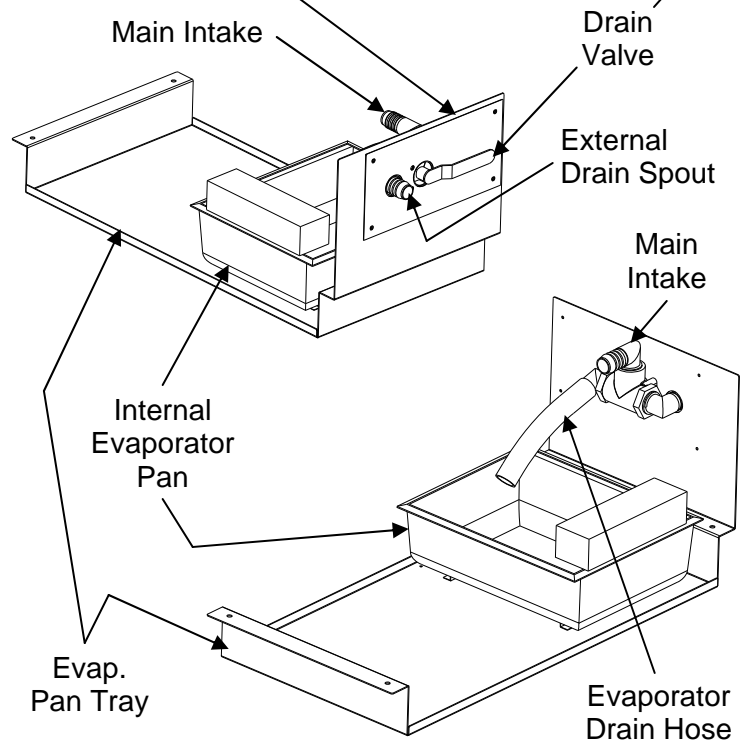

**ILLUSTRATIONS,
INSTRUCTIONS AND
INFORMATION
CONTAINED IN
THIS SECTION
PERTAINS TO
STORE EMPLOYEES
ONLY**

CLEANING SCHEDULE (TO BE PERFORMED BY STORE PERSONNEL)

Cleaning	Daily (or Nightly)	Weekly	Task
Clean Case Exterior	X		<u>Glass</u> : Clean side glass, front curved glass and sliding glass rear doors (optional) with a household or commercial glass cleaner.
	X		<u>Dipwell™</u> : Dipwell is used for thawing gelato scoops. See next page for illustrations and cleaning instructions.
Clean Case Interior	X		<u>Pans and Supports</u> : Remove pans & supports (leaving fan cover panels in case). Submerge in hot, soapy water and wash with sponge or clean cloth. Rinse, dry, and return to case.
		X	<u>Rear Sliding Doors</u> : Remove rear doors and clean with a household or commercial cleaner (service cases only).
		X	<u>Extended Internal Cleaning</u> : Extended internal cleaning required ensure proper performance. ⇒ See WEEKLY CLEANING (TO BE PERFORMED BY STORE PERSONNEL) section in this manual for specifics.

DIPWELL™ CLEANING (TO BE PERFORMED BY STORE PERSONNEL)

Dipwell™ is for thawing cold gelato scoops.

- Dipwell™ should be cleaned daily.
- Remove Dipwell™ simply by lifting up and out (as shown in below illustration).

- Submerge Dipwell™ in hot, soapy water and wash with sponge or clean cloth. Rinse, dry, and return to case.

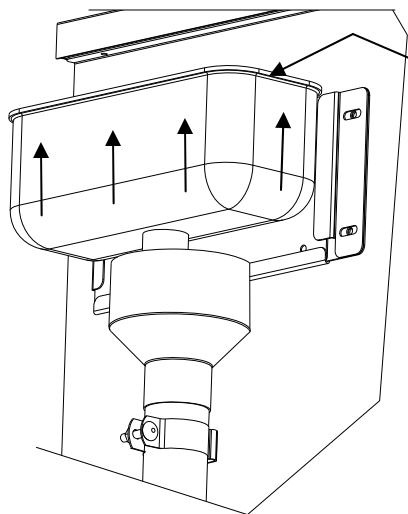

Dipwell™ can be completely removed from case (for cleaning) by simply lifting straight up and out.

Dipwell™ Illustration Showing Slide-Out Capability

- 
- A photograph of the Dipwell™ unit installed in a gelato case. The unit is a stainless steel tray with a handle on the right side. It is mounted on a base. Below the tray, there is a white plastic dipwell with a spigot on the left side. A water line is connected to the dipwell. A drain funnel is attached to the bottom of the dipwell, and a drain line is connected to it. The labels point to the following components:
- Water Spout
 - Stainless Steel Dipwell™
 - Dipwell™ Drain
 - Water Spigot
 - Dipwell™ Drain Funnel
 - Water Line
 - Dipwell™ Drain

Illustrations Shown May Not Exactly Reflect Every Feature or Option of Your Particular Case

⇒ CAUTION! YOU MUST PERFORM THIS CLEANING PROCEDURE EVERY 7 DAYS TO PREVENT ICE BUILDUP AND TO KEEP CASE RUNNING AT PROPER TEMPERATURE.

⇒ Note: Full defrost process takes at least 6 hours (and is often performed overnight).

⇒ Caution! You must remove product from case and place in freezer PRIOR TO defrosting this unit. See step #1, below.

1. Remove product from case. Place in freezer.
2. Determine whether your case has a Drain Spout and Valve (at rear of case).
 ⇒ If your case does NOT have a Drain Spout and Valve, you may jump to Step 5 in these instructions.
 ⇒ See illustrations at right for several valve designs.

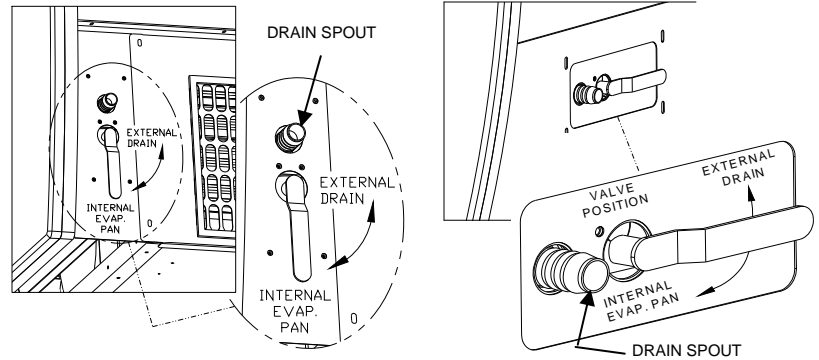

3. Connect hose (1" I.D.) to drain spout and run to floor drain or bucket. Or, if no hose is available, place bucket under drain spout.
4. After hose is connected (or bucket is in place), crank drain valve to External Drain position. This will allow the water to drain into floor drain (or bucket) while case is defrosting.

Defrost Procedure: This step takes place AFTER product has been removed and placed in freezer.

5. Locate temperature controller and main power switch (at rear-left or rear-right of your case) as shown in illustration at right.
6. Become familiar with the temperature controller. See illustration below.

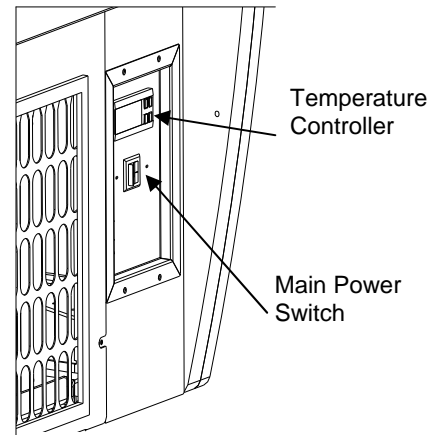

7. Case must now be placed in manual defrost mode. To do so, press and hold the Defrost Key (shown at right) for 5 seconds.

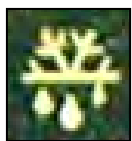

8. Defrost light (shown at left) will come on if defrost key has been properly pressed. If defrost light is not on, repeat step 7.

9. After 15 to 20 minutes, defrost light will turn off. Turn OFF main power switch. Allow to sit at least 6 hours (or overnight) before proceeding to next step.

⇒ Do not be alarmed if, after Defrost Light turns off, Compressor Light (shown at right) comes on. Turn off main power anyway.



Cleaning Instructions Continue On Next Page...

⇒CAUTION! YOU MUST PERFORM THIS CLEANING PROCEDURE EVERY 7 DAYS TO PREVENT ICE BUILDUP AND TO KEEP CASE RUNNING AT PROPER TEMPERATURE.

Cleaning Instructions Continued...

Note: These steps take place AFTER case has defrosted and power has been turned off.

The cleaning process may now begin:

10. Remove pans and support rails. Submerge in hot, soapy water. Clean with non-abrasive cloth or soft-bristled brush. See illustration #10 below.

11. Remove knurled head fasteners (at rear of unit). See illustration #11 below.

12. Lift up out of unit. Submerge in hot, soapy water. Clean with non-abrasive cloth or soft-bristled brush. See illustration #12 below.

Cleaning Instructions Continue On Next Page...

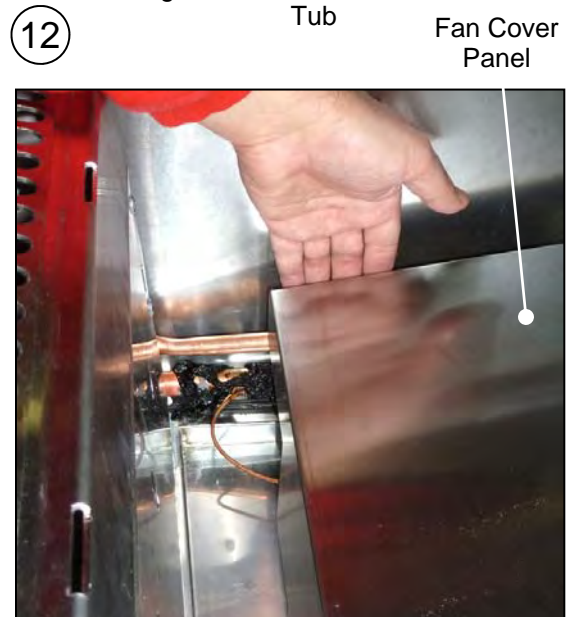
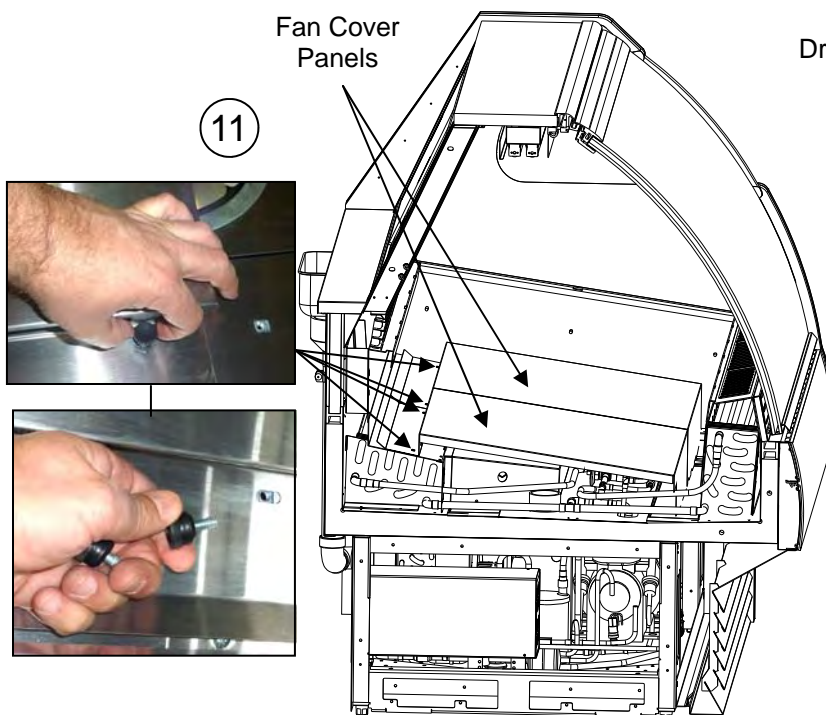
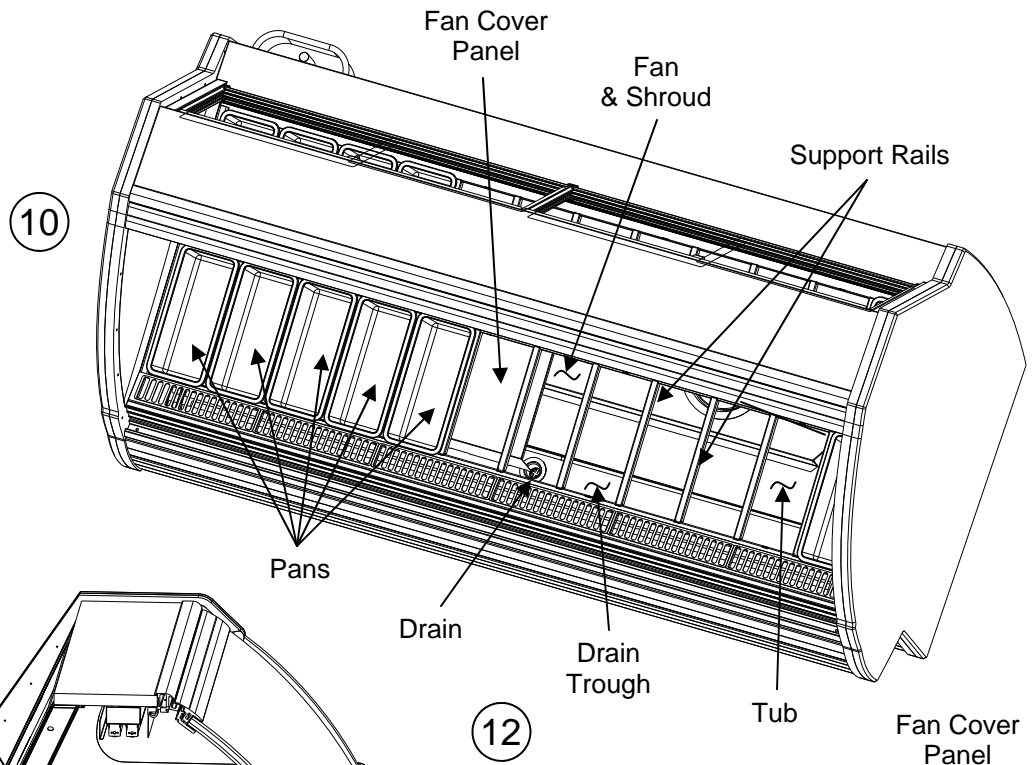

⇒ **CAUTION! YOU MUST PERFORM THIS CLEANING PROCEDURE EVERY 7 DAYS TO PREVENT ICE BUILDUP AND TO KEEP CASE RUNNING AT PROPER TEMPERATURE.**

Cleaning Instructions Continued...

Note: These steps take place **AFTER** case has defrosted and power has been turned off.

Optional: Check condition of tub around (and under) evaporator fan shroud. If oily residue and food particles warrant cleaning under fan shroud, follow steps 13-17. If not, continue at step #18.

- 13. Locate the evaporator fan shroud electrical plug at left of fan shroud.
- 14. Carefully remove electrical tape and disconnect dual-prong plug from receptacle.
- 15. Lift tabs from slots and lift rear fan shroud assembly upward from case.

- 16. Lift fan shroud assembly up and out.
- 17. View of tub area after all pans, support rails, fan cover panels and evaporator fan shroud have been removed from case.
- 18-20. Use bucket of hot water, mild detergent, soft bristled brush (or sponge) to clean away oily residue and food particles.
- 21. After all residue has been dislodged, use spray bottle or hose with slowly-flowing water to rinse out tub area to floor drains. **Caution! If using hose, do not splash onto electrical cords, fan or plug.**
- 22. Dry with paper towel or cloth when complete.

Cleaning Instructions Continue On Next Page...



⇒CAUTION! YOU MUST PERFORM THIS CLEANING PROCEDURE EVERY 7 DAYS TO PREVENT ICE BUILDUP AND TO KEEP CASE RUNNING AT PROPER TEMPERATURE.

Cleaning Instructions Continued...

Note: These steps take place AFTER case has defrosted and power has been turned off.

23. After cleaning, rinsing and drying tub area, is complete, place evaporator fan shroud assembly back into case.

24. Firmly reconnect two-pronged plug into receptacle.

25. Re-tape plug with existing electrical tape. If tape has lost its adhesiveness, replace.

26. Replace fan cover panels. Note: fan cover are NOT symmetrical.

27. Place center support rail across case (slots are at each inside end panel of case).

28. Place support rails across case (slots are at both front and rear of case). Optional Ice Cream Pan Adapter Plate: Place ice cream pan adapter plate across support rails as shown.

29. Set pans into place (in support rails).

30. Slowly lower curved glass.

> Turn crank drain valve back to the internal evaporator pan position. If no floor drain was used, empty bucket of its contents.

> Turn main power switch back on.

Caution! Case must run at least 1 1/2 hours (90 minutes) to assure proper case temperatures before returning product to case.

> Return product to the case.



TROUBLESHOOTING (TO BE PERFORMED BY STORE PERSONNEL)

Doors/Glass Won't Shut Properly	Check that there is no residue or obstruction in door track.
System Is Not Operating	Check the MAIN power switch is on.
	If power cord is used, check that it is properly plugged in.
Case Lights Are Not Working	Be sure ALL light bulb pins are properly aligned with slots and rotated properly.
	Check for burned out bulbs.
	Clean dirt and dust from the bulbs to prevent flickering.
	After performing above checkpoints, if lights are still not working, contact your service provider or certified electrician to check for faulty ballast.

**ILLUSTRATIONS,
INSTRUCTIONS AND
INFORMATION
CONTAINED IN THIS
SECTION PERTAINS
TO TRAINED SERVICE
PROVIDERS ONLY**

PREVENTIVE MAINTENANCE (TO BE PERFORMED BY TRAINED SERVICE PROVIDERS)

PREVENTIVE MAINTENANCE	FREQUENCY	INSTRUCTIONS
Case Exterior	Monthly	<p>Condensing Coil: <i>Disconnect power from case before cleaning.</i></p> <ul style="list-style-type: none"> • Remove Rear Grille (by removing 4 screws). • Roll / Slide out Refrigeration Assembly. <u>Note:</u> At initial slide-out, it may be necessary to remove two (2) Compressor Pan Shipment Screws for Refrigeration Assembly to slide out. • Use air pressure or industrial strength vacuum; clean dust and dirt that may collect on the Condenser Coil. See illustration below. • Caution! Coil fins are sharp. Handle with care! • Slide/Roll Condensing Unit Assembly back under case. • Replace Rear Grille to case (4 screws). • See illustration below.
	Quarterly	<p>Optional Clean Sweep™ Condensing Coil: <i>Disconnect power from case before cleaning Clean Sweep™ Condenser Coil!</i></p> <ul style="list-style-type: none"> • Remove Rear Grille (by removing 4 screws). • Slide/Roll out condensing unit assembly. • Remove the four (4) screws holding the Clean Sweep™ rails intact. • Remove the Clean Sweep™ rail. • Wash rails' brushes in hot water and mild soap solution. • If brushes are worn, they must be replaced. Call Technical Service Department to replace. Toll-Free number is listed at end of manual. • Clean Condensing Coil: Use air pressure or industrial strength vacuum; clean the dust and dirt that may collect on the Condenser Coil. • Caution! Coil fins are sharp. Handle with care! • Reattach Clean Sweep rail to condensing unit (4 screws). • Slide/Roll Condensing Unit Assembly back under case. • Replace Rear Grille to case (4 screws). • See photos below.

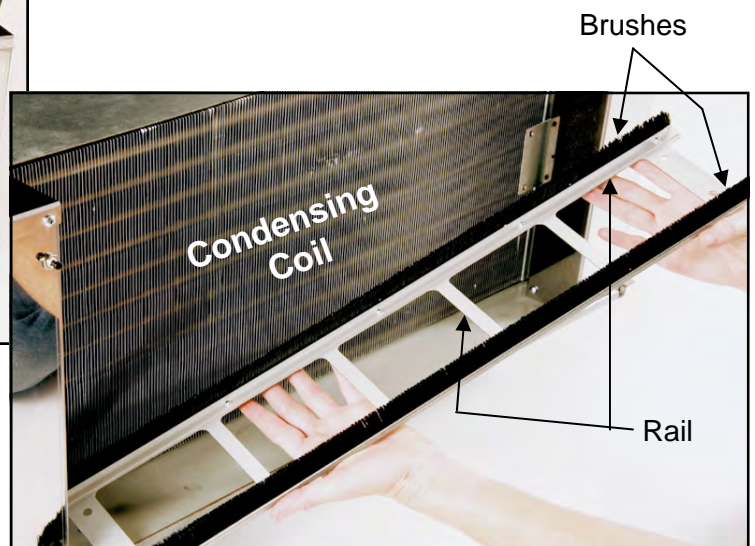
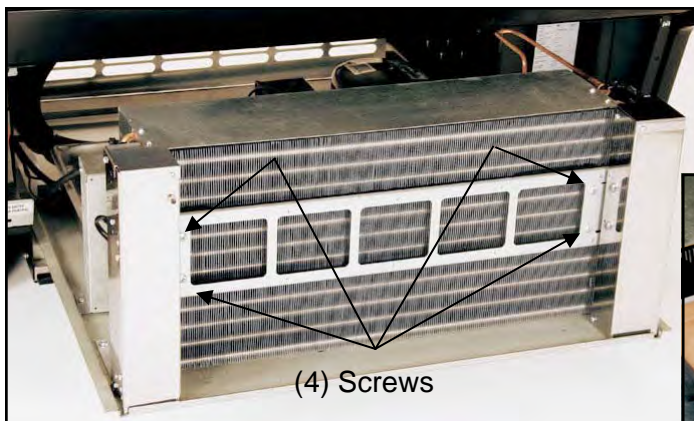

--- Above photos are taken after rear grille has been removed from case ---

PREVENTIVE MAINTENANCE (TO BE PERFORMED BY TRAINED SERVICE PROVIDERS), CONT'D

PREVENTIVE MAINTENANCE	FREQ.	INSTRUCTIONS
Case Interior	Quarterly	<p>Internal Cleaning: <i>Disconnect power from case before cleaning.</i></p> <ol style="list-style-type: none"> 1. Remove pans and support rails. 2. Remove fan cover panels (after removing knurled head fasteners). 3. Wipe down fan shroud and fan blades with warm, soapy water and soft cloth. Then, disconnect (screw removal is required) and remove from case. 4. Clean out drains. Use warm, soapy water and soft cloth to wipe down TXVs, tub, troughs, copper tubing, etc.

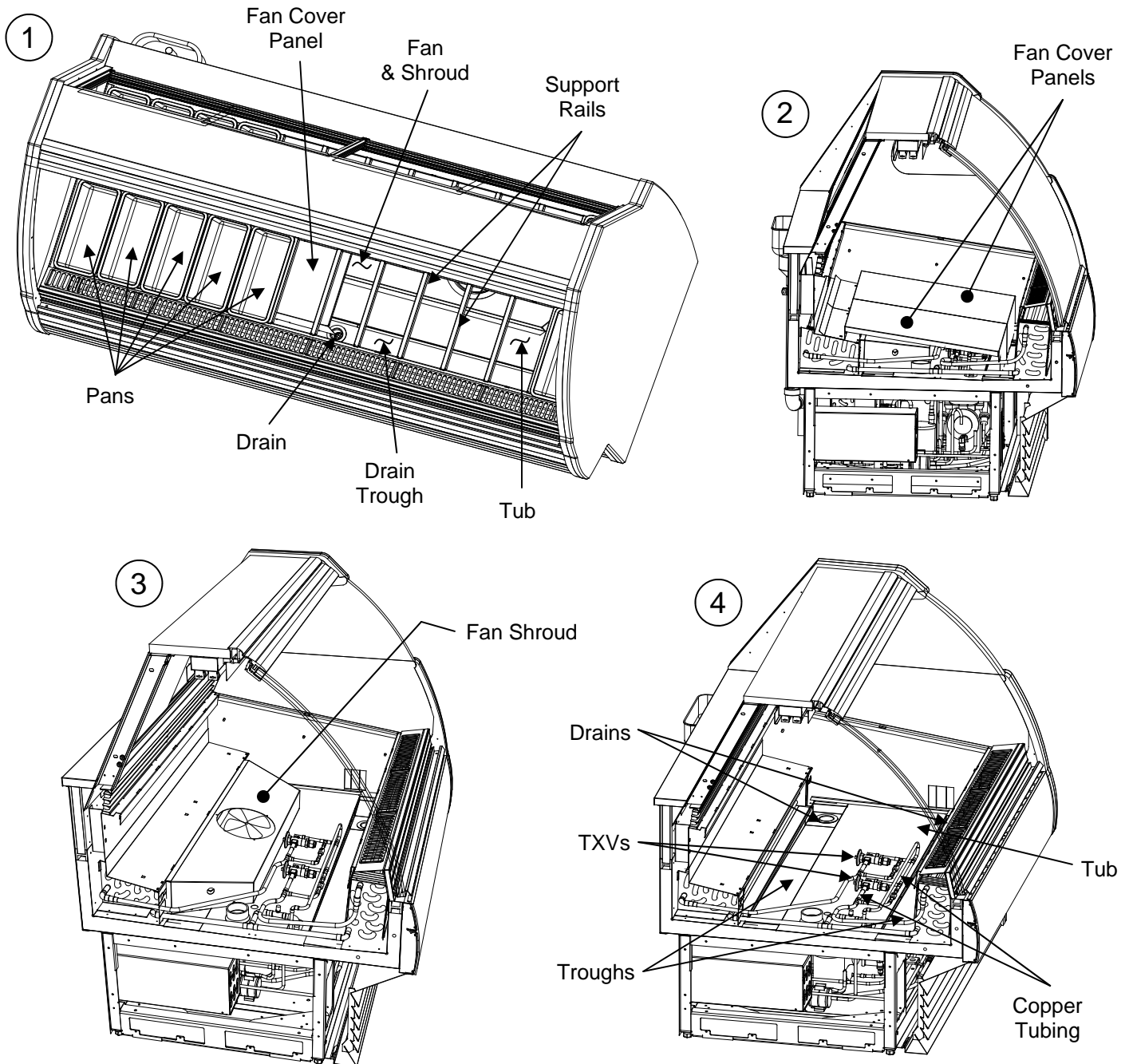

PREVENTIVE MAINTENANCE (TO BE PERFORMED BY TRAINED SERVICE PROVIDERS), CONT'D

PREVENTIVE MAINTENANCE	FREQ.	INSTRUCTIONS
Condensate Pan	Quarterly	<p>Condensate Pan: <i>Disconnect power from case and allow pan to cool before cleaning.</i></p> <ul style="list-style-type: none"> • Remove rear panel (screw removal is required). • As illustration below shows, pan may be accessed at either left or right sides. • Use a scrub-brush and a de-scaling solution such as CLR® (to prevent corrosion, lime and rust). Follow instructions on container as to proper dilution, safety precautions and scrubbing method. • After thoroughly cleaning, rinse thoroughly with clean water (in spray bottle) and wipe dry with sponge, paper towel or wet/dry vacuum. • Replace rear panel. • Note: For extreme residue buildup, pan may be removed from case (screw removal is required) and cleaned in sink. Caution! Due to electrical components on the pan assembly, do not submerge in water while cleaning. Return to case in reverse order it was removed. Replace rear panel.

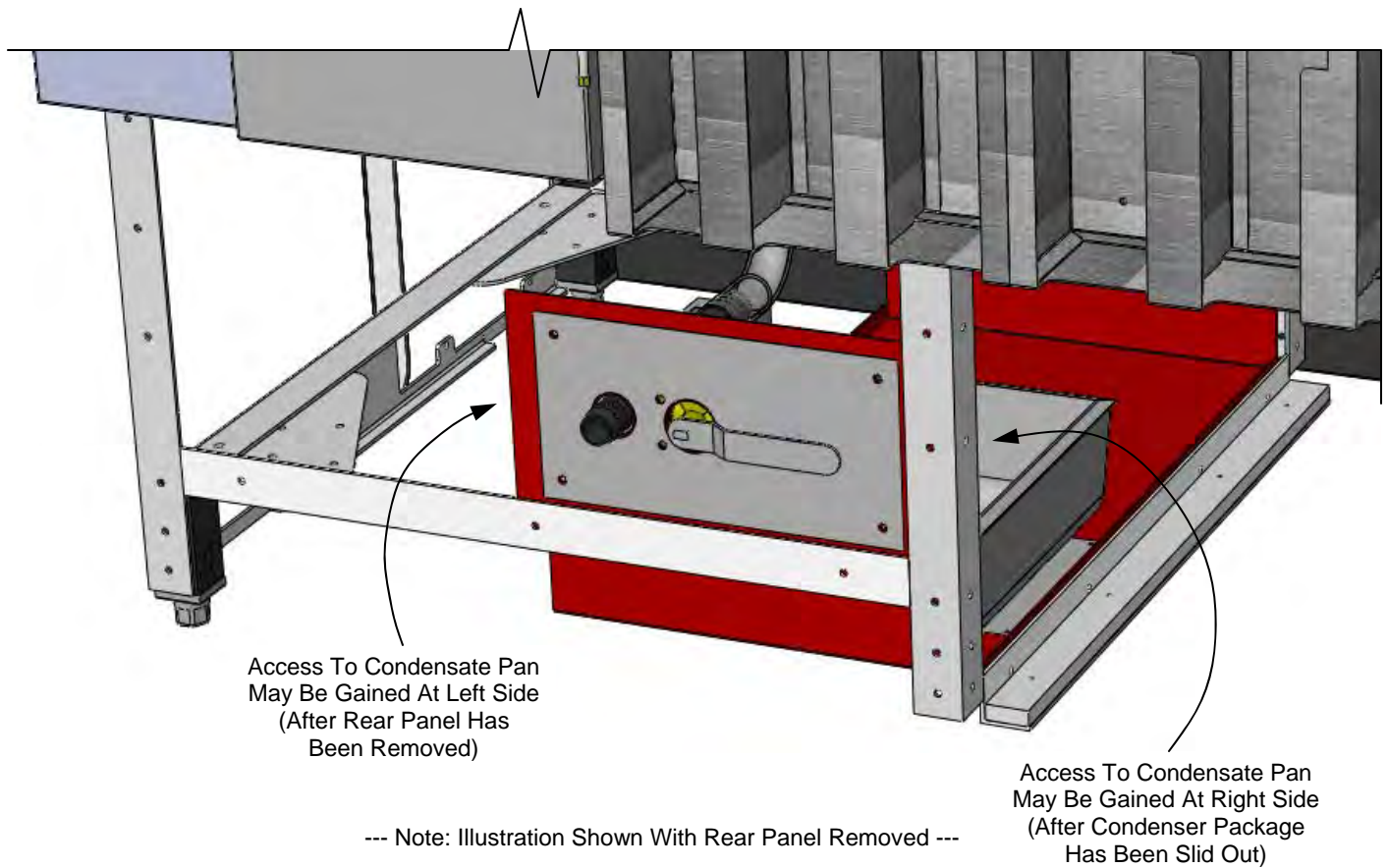

PREVENTIVE MAINTENANCE (TO BE PERFORMED BY TRAINED SERVICE PROVIDERS), CONT'D

PREVENTIVE MAINTENANCE	FREQ.	INSTRUCTIONS
Condensate Package	Quarterly	<p>Condensate Package <i>Disconnect power from case before cleaning.</i></p> <ul style="list-style-type: none"> • Remove rear panel (screw removal is required). • Slide condenser package out from under case rear. • Use moist cloth to wipe off dust & debris that collects on various parts (fans, sight glass, TXV, etc.). • Illustration below shows various components that should be wiped down. • Slide condenser package back under case. • Replace rear panel.

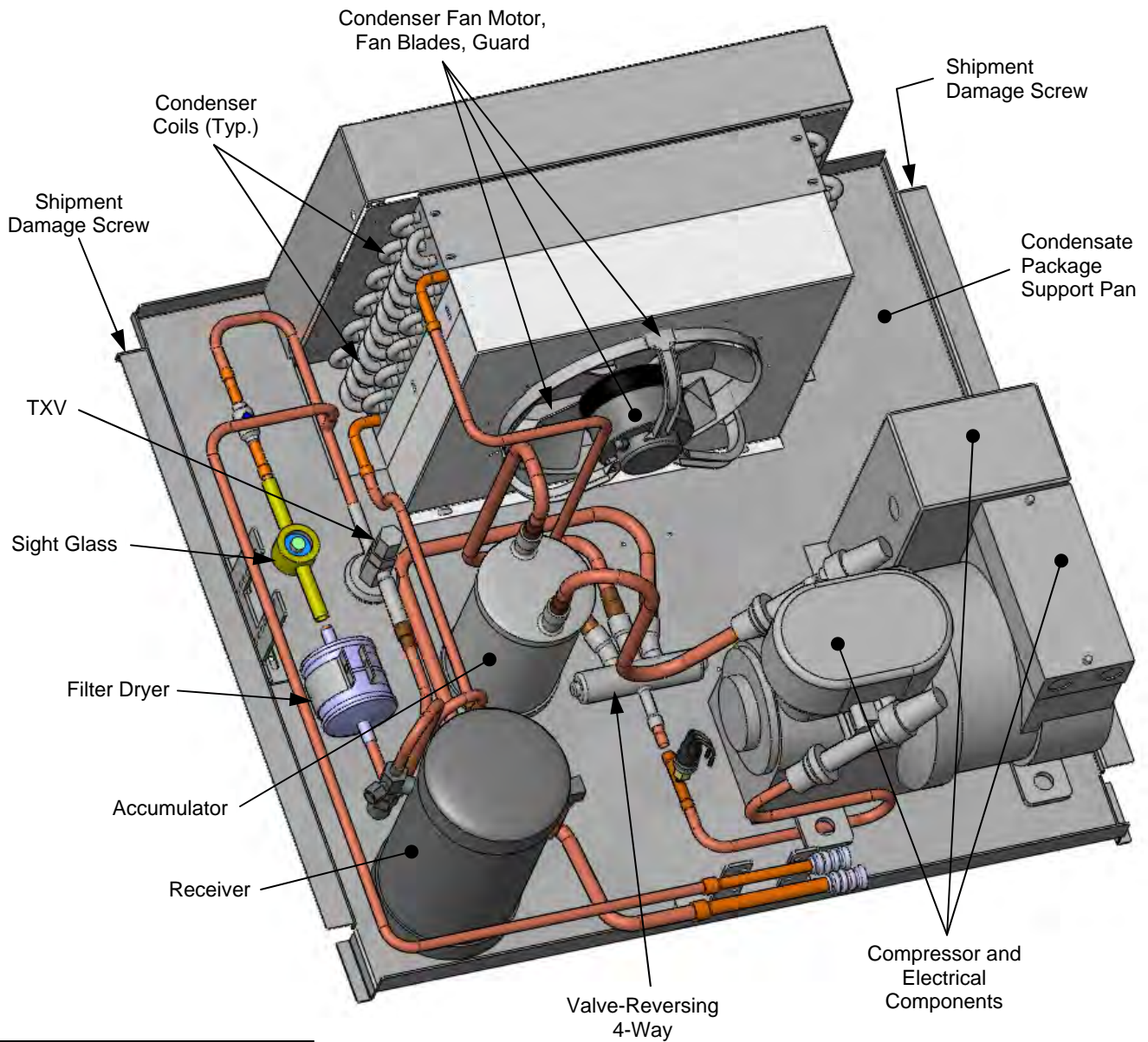

Note: Model G12F.5150 Is Shown.
Your Model May Slightly Differ

TROUBLESHOOTING (TO BE PERFORMED BY TRAINED SERVICE PROVIDERS)

Doors/Glass Won't Shut Properly	Check that there is no residue or obstruction in door track.
	Check that the case is aligned, level and plumb.
System Is Not Operating	If power cord is used, check that it is properly plugged in.
	Check the MAIN power switch is on.
	Confirm that the utility power is on.
	Check the circuit breaker box for tripped circuits. See GFCI Breaker Use Requirement specifics in Overview and Warnings section of manual.
Case Lights Are Not Working	Be sure ALL light bulb pins are properly aligned with slots and rotated properly.
	Check for burned out bulbs.
	Clean dirt and dust from the bulbs to prevent flickering.
	After performing above checkpoints, if lights are still not working, contact your service provider or certified electrician to check for faulty ballast.

**GENERAL TECHNICAL
INFORMATION
(SERIAL LABEL INFO /
TEMPERATURE
CONTROLLER
INFORMATION /
TECHNICAL SERVICE
INFORMATION), ETC.**

Serial Label Location & Information Listed / Technical Information & Service

- Serial labels are located near the electrical access on your case.
- Serial labels contain electrical, temperature & refrigeration information, as well as regulatory standards to which the case conforms.
- For additional technical information and service, see the *TECHNICAL SERVICE* page in this manual for instructions on contacting Structural Concepts' Technical Service Department.
- See images below for samples of both refrigerated and non-refrigerated serial labels.





888 E. Porter Rd · Muskegon, MI 49441

ENCORE[®] MODEL HV74RSS SCROLL
SERIES SERIAL NO.

FOR PARTS AND SERVICE
CALL 1-800-433-9489

SAMPLE ONLY

  3048256 CONFORMS TO UL STD 471 CONFORMS TO NSF STD 7 CERTIFIED TO CAN/CSA STD C22.2 NO 120	ELECTRICAL RATING REFRIGERANT DESIGN PRESSURE MINIMUM CIRCUIT MAXIMUM OVERCURRENT	120/1/60 24A R404A AMOUNT ?? OZ HIGH 450 LOW 200 30A 30A
---	---	--

SAMPLE ONLY

Super Heat Temp	8-10°F
BTUH Requirements	9,738 BTUH @ 20° F SST
Defrost	6 defrosts per day, 45° F termination, 45 min. failsafe

SAMPLE ONLY

----- Sample Serial Label For Refrigerated Case -----



888 E. Porter Rd · Muskegon, MI 49441

Addenda[®] PC5682 txtRemote
txtSerialNumber

120 VOLTS 60 HZ SINGLE PHASE 1.84AMP

FOR PARTS OR SERVICE CALL
STRUCTURAL CONCEPTS
AT
1-800-433-9489

SAMPLE ONLY

UL

UL

----- Sample Serial Label For Non-Refrigerated Case -----

CAREL

ir33 platform

Integrated Electronic
Microprocessor Controller



Programming The Instrument

To Modify The Setpoint

Set Press and hold the "SET" key for at least 1 second.

▲/aux **def/▼** 2. Use arrow keys ▲ ▼ on temperature controller to increase (or decrease) the setpoint.

Set 3. Quickly press and release the "SET" key again.

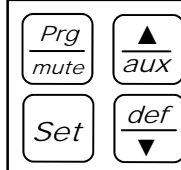

To Modify Defrost, Differential, Other Parameters

Prg/mute **Set** 1. Press & hold "Prg" & "SET" keys together for five (5) seconds; display will flash "0", representing password prompt.

Set 2. Confirm by pressing "SET" key.

▲/aux **def/▼** 3. Press ▲ or ▼ to reach the category to be modified.

Set 4. Press "SET" to modify this selected parameter.

▲/aux **def/▼** 5. Increase or decrease the value using the ▲ or ▼ button respectively.

Set 6. Press the "SET" key to temporarily save the new value and return to the display of the parameter.

Prg/mute 7. Press & hold the "Prg" key for at least 5 seconds to save changes. This action will also mute the audible alarm (buzzer) & deactivate the alarm relay.

How To Change Reading From Fahrenheit (°F) To Celsius (°C)

Prg/mute **Set** 1. Press and hold "Prg" and "SET" keys together for at least 5 seconds; display will show "0" (password prompt).

Set 2. Confirm by pressing "SET" key.

▲/aux **def/▼** 3. Press ▲ or ▼ until reaching the parameter "/ 5".

Set 4. Press "SET" to modify this selected parameter.

▲/aux **def/▼** 5. Press ▲ or ▼ to change value to desired setting: "0" for Celsius (°C) or "1" for Fahrenheit (°F).

Set 6. Press "SET" key to temporarily save the new value and return to the display of the parameter.

Prg/mute 7. Press & hold "Prg" key for at least 5 seconds to save changes. **Note! All values will automatically convert to new scale. No conversion is required.**

Warning! Save Your Parameter Settings!

1. To store the new parameter values, PRESS and HOLD the "Prg" key for at least 5 seconds.
2. All modifications made to parameters will be lost if you do NOT press a button within 60 seconds. Should this "timeout" occur, normal operational settings (prior to modifications being made) will resume.
3. If the instrument is switched off before pressing the "Prg" key, all modifications to parameters will be lost.

def/▼ **To Activate Manual Defrost**
Press and hold "def" key for at least 5 seconds.

▲/aux **To Activate / Deactivate Auxiliary Output**
Press and hold the "aux" key for 1 second.

Prg/mute **▲/aux** **To Reset Any Alarms With Manual Reset**
Press and hold the "Prg" and "aux" key for at least 1 second.

CAREL

ir33 platform
**Integrated Electronic
 Microprocessor Controller**



User Interface - Display

ICON	FUNCTION	DESCRIPTION	Normal operation			Start up
			ON	OFF	BLINK	
	COMPRESSOR	ON when the compressor starts. Flashes when the activation of the compressor is delayed by safety times.	Compressor on	Compressor off	awaiting activation	
	FAN	ON when the fan starts. Flashes when the activation of the fan is prevented due to external disabling or procedures in progress.	Fan on	Fan off	awaiting activation	
	DEFROST	ON when the defrost is activated. Flashes when the activation of the defrost is prevented due to external disabling or procedures in progress.	Defrost in progress	Defrost not in progress	awaiting activation	
	AUX	Flashes if the anti-sweat heater function is active, ON when the auxiliary output (1 and/or 2) selected as AUX (or LIGHT in firmware version 3.6) is activated.	AUX auxiliary output active (version 3.6 light auxiliary output active)	AUX auxiliary output not active	Anti-sweat heater function active	
	ALARM	ON following pre-activation of the delayed external digital input alarm. Flashes in the event of alarms during normal operation (e.g. high/low temperature) or in the event of alarms from an immediate or delayed external digital input.	Delayed external alarm (before the time 'A7' elapses)	No alarm present	Alarms in norm. operation (e.g. High/low temperature) or immediate or delayed alarm from external digital input	
	CLOCK	ON if at least one timed defrost has been set. At start-up, comes ON for a few seconds to indicate that the Real Time Clock is fitted.	If at least 1 timed defrost event has been set	No timed defrost event set	Alarm clock	ON if real-time clock present
	LIGHT	Flashes if the anti-sweat heater function is active, ON when the auxiliary output (1 and/or 2) selected as LIGHT is activated (in firmware version 3.6 it does not flash in anti-sweat heater mode and comes on when the dead band output is active).	Light auxiliary output on (version 3.6 dead band auxiliary output active)	Light auxiliary output off	Anti-sweat heater function active (version 3.6 does not flash in anti-sweat heater mode)	
	SERVICE	Flashes in the event of malfunctions, for example E2PROM errors or probe faults.		No malfunction	Malfunction (e.g. E2PROM error or probe fault). Contact service	
	CONTINUOUS CYCLE	ON when the CONTINUOUS CYCLE function is activated. Flashes if the activation of the function is prevented due to external disabling or procedures in progress (E.g.: minimum compressor OFF time).	CONTINUOUS CYCLE operation activated	CONTINUOUS CYCLE function not activated	CONTINUOUS CYCLE operation requested	

Summary Table of Alarm and Signals: Display, Buzzer and Relay

Code	Icon on the display	Alarm relay	Buzzer	Reset	Description
rE	flashing	on	on	automatic	virtual control probe fault
E0	flashing	off	off	automatic	room probe S1 fault
E1	flashing	off	off	automatic	defrost probe S2 fault
E2	flashing	off	off	automatic	probe S3 fault
E3	flashing	off	off	automatic	probe S4 fault
E4	flashing	off	off	automatic	probe S5 fault
	No	off	off	automatic	probe not enabled
LO	flashing	on	on	automatic	low temperature alarm
HI	flashing	on	on	automatic	high temperature alarm
AFr	flashing	on	on	manual	antifreeze alarm
IA	flashing	on	on	automatic	immediate alarm from external contact
dA	flashing	on	on	automatic	delayed alarm from external contact
dEF	on	off	off	automatic	defrost running
Ed1	No	off	off	automatic/manual	defrost on evaporator 1 ended by timeout
Ed2	No	off	off	automatic/manual	defrost on evaporator 2 ended by timeout
Pd	flashing	on	on	automatic/manual	maximum pump down time alarm
LP	flashing	on	on	automatic/manual	low pressure alarm
AtS	flashing	on	on	automatic/manual	autostart in pump down
cht	No	off	off	automatic/manual	high condenser temperature pre-alarm
CHT	flashing	on	on	manual	high condenser temperature alarm
dor	flashing	on	on	automatic	door open too long alarm
EE	flashing	off	off	automatic	E2prom error, unit parameters
EF	flashing	off	off	automatic	E2prom error, operating parameters
ccb	Signal				start continuous cycle request
ccE	Signal				end continuous cycle request
dFb	Signal				start defrost call
dFE	Signal				end defrost call
On	Signal				switch ON
off	Signal				switch OFF
rES	Signal				reset alarms w/manual reset / reset HACCP alarms / reset temp. monitoring

CAREL

ir33 platform

Integrated Electronic
Microprocessor Controller



Summary Table of Operating Parameters

CODE	PARAMETER	UOM*	TYPE	MINIMUM	MAXIMUM	DEFAULT
/5	Select Celsius (°C) or Fahrenheit (°F)	flag	C	0	1	For Case Specific Defaults See Serial Label Located Near Electrical Access On Your Case. For Additional Technical Information Call Structural Concepts Technical Service Dept. at 1(800) 433.9489
/c1	Calibration of probe 1	°C/°F	C	-20	20	
/c2	Calibration of probe 2	°C/°F	C	-20	20	
St	Temperature set point	°C/°F	F	r2	r1	
rd	Control delta	°C/°F	F	20	0.1	
dl	Interval between defrosts	hours	F	0	250	
dt1	End defrost temperature, evaporator	°C/°F	F	-50	200	
dP1	Maximum defrost duration, evaporator	min	F	1	250	
d6	Display on hold during defrost	-	C	0	2	
dd	Dripping time after defrost	min	F	0	15	
d/1	Display of defrost probe 1	°C/°F	F	-	-	

* Unit Of Measure

STRUCTURAL CONCEPTS CORPORATION TECHNICAL SERVICE
PHONE NUMBER: 1.800.433.9489 or For Your Master Service Agent See
WWW.STRUCTURALCONCEPTS.COM/Contact/Master_Service_Agents.asp

LIMITED WARRANTY

All sales by Structural Concepts Corporation (SCC) are subject to the following limited warranty. "Goods" refers to the product or products being sold by SCC.

Warranty Scope: Warranty is for equipment sold in the United States, Canada, Mexico and Puerto Rico. Equipment sold elsewhere may carry modified warranty.

Warranty; Remedies; Limitations. SCC warrants that if any Goods are found by an authorized representative of SCC not to be of good material or workmanship within one year of the date of shipments SCC will, at its option after inspection by an authorized representative, replace any defective Good or pay the reasonable cost of replacement for any such defective Goods, provided that written notice of the defect is given to SCC within 30 days of the appearance of such defect. If notice is not given within such period, any claim for breach of warranty shall be conclusively deemed to have been waived and SCC shall not be liable under this warranty. If SCC is unable to repair or replace the defective Goods, SCC shall issue a credit to the Purchaser for all or part of the purchase price, as SCC shall determine. The replacement or payment in the manner described above shall be the sole and exclusive remedy of Purchaser for a breach of this warranty. If any Goods are defective or fail to conform to this warranty, SCC will furnish instructions for their disposition. No Goods shall be returned to SCC without its prior consent.

SCC's liability for any defect in the Goods shall not exceed the purchase price of the Goods. SCC SHALL HAVE NO LIABILITY TO PURCHASE FOR CONSEQUENTIAL DAMAGES OF ANY KIND WHATSOEVER, INCLUDING, BUT NOT LIMITED TO, PERSONAL INJURY, PROPERTY DAMAGE, LOST PROFITS, OR OTHER ECONOMIC INJURY DUE TO ANY DEFECT IN THE GOODS OR ANY BREACH OF SCC, SCC SHALL NOT BE LIABLE TO THE PURCHASER IN TORT FOR ANY NEGLIGENT DESIGN OR MANUFACTURE OF THE GOODS, OR FOR THE OMISSION OF ANY WARNING THEREFROM.

SCC shall have no obligation or liability under this warranty for claims arising from any other party's (including Purchaser's) negligence or misuse of the Goods or environmental conditions. This warranty does not apply to any claim or damage arising for or cause by improper storage, handling, installation, maintenance, or from fire, flood, accidents, structural defects, building settlement or movement, acts of God, or other causes beyond SCC's control.

Except as expressly stated herein, SCC makes no warranty, express, implied, statutory or otherwise as to any parts or goods not manufactured by SCC. SCC shall warrant such parts or Goods only (I) against such defects, (II) for such periods of time, and (III) with such remedies, as are expressly warranted by the manufacturer of such parts of Goods. Notwithstanding the foregoing, any warranty with respect to such parts of Goods and any remedies available as a result of a breach thereof shall be subject to all of the procedures, limitations, and exclusions set forth herein.

THE WARRANTIES HEREIN ARE IN LIEU OF ALL WARRANTIES, EXPRESS, IMPLIED, STATUTORY, OR OTHERWISE. IN PARTICULAR, SCC MAKES NO WARRANTY OF MERCHANTABILITY OR FITNESS FOR A PARTICULAR PURPOSE.

No representative, agent or dealer of SCC has authority to modify, expand, or extend this Warranty, to waive any of the limitations or exclusions, or to make any different or additional warranties with respect to Goods.

Period of Limitations. No claim, suit or other proceeding may be brought by Purchaser for any breach of the foregoing warranty or this Agreement by SCC or in any way arising out of this Agreement or relating to the Goods after one year from the date of the breach. In the interpretation of this limitation on action for a breach by SCC, it is expressly agreed that there are no warranties of future performance of the goods that would extend that period of limitation herein contained for bringing an action.

Indemnifications. Purchaser agrees to indemnify, hold harmless, and defend SCC if so requested, from any and all liabilities, as defined herein, suffered, or incurred by SCC as a result of, or in connection with, any act, omission, or use of the Goods by Purchaser, its employees or customers, or any breach of this Agreement by Purchaser. Liabilities shall include all costs, claims, damages, judgments, and expenses (including reasonable attorney fees and costs).

Remedies of SCC. SCC's rights and remedies shall be cumulative and may be exercised from time to time. In a proceeding or action relating to the breach of this Agreement by Purchaser, Purchaser shall reimburse SCC for reasonable costs and attorney's fees incurred by SCC. No waiver by SCC of any breach of Purchaser shall be effective unless in writing nor operate as a waiver of any other breach of the same term thereafter. SCC shall not lose any right because it has not exercised it in the past.

Applicable Law. This Agreement is made in Michigan and shall be governed by and interpreted according to Michigan law. Any lawsuit arising out of this Agreement or the Goods may be handled by a federal or state court whose district includes Muskegon County, Michigan, and Purchaser consents that such court shall have personal jurisdiction over Purchaser.

Miscellaneous. If any provision of this Agreement is found to be invalid or unenforceable under any law, the provision shall be ineffective to that extent and for the duration of the illegality, but the remaining provisions shall be unaffected. Purchaser shall not assign any of its rights nor delegate any of its obligations under this Agreement without prior written consent of SCC. This Agreement shall be binding upon and inure to the benefit of SCC and Purchaser and each of their legal representatives, successors and assigns.

SCC warrants its products to be free of defects in materials and workmanship under normal use and service for a period of one (1) year from the date of delivery.

This warranty is extended only to the original purchaser for use of the Goods. It does not cover normal wear parts such as plastic tongs, tong holders, tong cables, bag holders, or acrylic dividers.

General Conditions. All service labor and/or parts charges are subject to approval by SCC. Contact the Customer Service Department in writing or call 231-798-8888.

All claims must contain the following information: (1) model & serial code number of equipment; (2) the date and place of installation; (3) the name and address of the agency which performed the installation; (4) the date of the equipment failure; and (5) a complete description of the equipment failure and all circumstances relating to that failure.

Once the claim has been determined to be a true warranty claim by SCC's Customer Service Department, the following procedure will be taken: (1) replacement parts will be sent at no charge from SCC on a freight prepaid basis; (2) reimbursement for service labor will be paid if the following conditions have been met - (a) prior approval of service agency was awarded from the Customer Service Department; and (b) an itemized statement of all labor charges incurred is received by the Customer Service Department. The cost of the service labor reimbursement will be based on straight time rates and reasonable time for the repair of the defect.

If problems occur with any compressor, notify SCC's Customer Service Department immediately. Any attempt to repair or alter the unit without prior consent from the Customer Service Department will render any warranty claim null and void. This warranty and protection plan does not apply to any condensing unit or any part thereof which has been subject to accident, negligence, misuse, or abuse, or which has not been operated in accordance with the manufacturer's recommendations or if the serial number of the unit has been altered, defaced, or removed.

Limit of Liability. The limit of liability of SCC toward the exchange cost of the original condensing unit, F.O.B. SCC, Norton Shores, MI, of each motor-compressor assembly replaced during the warranty shall not exceed manufacturer's current established wholesaler's exchange price and in no case shall the labor of removing or replacing the motor-compressor or parts thereof be the responsibility of SCC.