



Challenger Series
OPERATORS MANUAL

Manual No. [513562](#)

Rev.2

This manual provides basic information about the machine. Instructions and suggestions are given covering its operation and care.

The illustrations and specifications are not binding in detail. We reserve the right to make changes to the machine without notice, and without incurring any obligation to modify or provide new parts for machines built prior to date of change.

DO NOT ATTEMPT to operate the machine until instructions and safety precautions in this manual are read completely and are thoroughly understood. If problems develop or questions arise in connection with installation, operation, or servicing of the machine, contact Stoelting.



stoeltingfoodservice.com

Stoelting Foodservice Equipment
502 Highway 67
Kiel, WI 53042-1600
U.S.A.

Main Tel: 800.558.5807
Fax: 920.894.7029

Customer Service: 888.429.5920
Fax: 800.545.0662
Email: foodservice@stoelting.com

© 2014 PW Stoelting, LLC

A Few Words About Safety

Safety Information

Read and understand the entire manual before operating or maintaining Stoelting equipment.

This manual provides the operator with information for the safe operation and maintenance of Stoelting equipment. As with any machine, there are hazards associated with their operation. For this reason safety is emphasized throughout the manual. To highlight specific safety information, the following safety definitions are provided to assist the reader.

The purpose of safety symbols is to attract your attention to possible dangers. The safety symbols, and their explanations, deserve your careful attention and understanding. The safety warnings do not by themselves eliminate any danger. The instructions or warnings they give are not substitutes for proper accident prevention measures.

If you need to replace a part, use genuine Stoelting parts with the correct part number or an equivalent part. We strongly recommend that you do not use replacement parts of inferior quality.



Safety Alert Symbol:

This symbol Indicates danger, warning or caution. Attention is required in order to avoid serious personal injury. The message that follows the symbol contains important information about safety.

Signal Word:

Signal words are distinctive words used throughout this manual that alert the reader to the existence and relative degree of a hazard.



The signal word "WARNING" indicates a potentially hazardous situation, which, if not avoided, may result in death or serious injury and equipment/property damage.



The signal word "CAUTION" indicates a potentially hazardous situation, which, if not avoided, may result in minor or moderate injury and equipment/property damage.

CAUTION

The signal word "CAUTION" not preceded by the safety alert symbol indicates a potentially hazardous situation, which, if not avoided, may result in equipment/property damage.

NOTE (or NOTICE)

The signal word "NOTICE" indicates information or procedures that relate directly or indirectly to the safety of personnel or equipment/property.

TABLE OF CONTENTS

SECTION 1 - DESCRIPTION AND SPECIFICATIONS

1.1 Description	1
1.2 Specifications	1

SECTION 2 - INSTALLATION

2.1 Shipment and Transit	3
2.2 Installation	3
2.3 Remote Condenser	5
2.4 Mix Pump Installation and Checkout (Remote Models)	7

SECTION 3 - OPERATING INSTRUCTIONS

3.1 Safety Information	9
3.2 Safety Precautions	10
3.3 Operating Controls	11
3.4 Spigot Switch	11
3.5 Drive Motor Overload	11
3.6 Power Switch (CLEAN-OFF-SERVE)	11
3.7 Freezing Switch	11
3.8 Door Interlock Switch	11
3.9 Remote Pump Switch	11
3.10 Dispense Rate Adjuster	11
3.11 High Pressure Cut Out	11
3.12 Sanitizing Procedures	11
3.13 Initial Freeze Down and Operation	12
3.14 Removing Mix From the Freezer	13
3.15 Disassembly and Assembly of Front Door (Model 217 and 238R)	14
3.16 Disassembly and Assembly of Auger	16
3.17 Disassembly and Assembly of Mix Line Adaptor (Remote Models)	17
3.18 O-Ring Removal and Care	17
3.19 Cleaning of Freezer and Freezer Parts	17
3.20 Sanitize Freezer Parts	18

SECTION 4 - MAINTENANCE INSTRUCTIONS

4.1 Freezer Adjustments	19
4.2 Product Temperature Adjustment	19
4.3 Drive Belt Tension Adjustment	19
4.4 Condenser Cleaning (Air-Cooled Freezers)	19
4.5 Preventative Maintenance	20
4.6 Extended Storage	20
4.7 Troubleshooting	20

SECTION 5 - HOW TO ORDER REPLACEMENT PARTS

5.1 How To Order Replacement Parts	23
5.2 Parts List and Reference Drawings	23

LIST OF ILLUSTRATIONS

Figure	Title	Page
1	Caster Options	3
2	Water Connections	4
3	Electrical Connections	4
4	Auger Shaft Rotation	5
5	Remote Condenser	6
6	Mix Transfer Line & Pump Installation	8
7	Warning Label Locations	10
8	Operating Controls	11
9	Air Bleed	12
10	Pump Switch	12
11	Front Door Disassembly	14
12	Spinner Assembly	15
13	Auger with Rubber Rear Seal	16
14	Auger Disassembly	16
15	Plastic Parts	16
16	Auger Assembly	16
17	Auger Flight Spring	17
18	Mix Line Adapter	17
19	Removing O-rings	17
20	Potentiometer	19
21	Belt Adjustment	19

SECTION 1 DESCRIPTION AND SPECIFICATIONS

1.1 DESCRIPTION

The Stoelting Challenger pressurized freezers are available in water cooled or air cooled versions (completely self-contained or with remote condensers). Some models are available with built-in hoppers or remote mix pump feed. Freezers are equipped with fully automatic controls to provide for consistent temperature and uniformity of product.

Refer to Mix Pump Manual for complete information on the operation of the mix pump.

1.2 SPECIFICATIONS

MODEL	DESCRIPTION
217	Single Barrel - Soft Serve - Hopper Pump Style
217R	Twin Barrel - Soft Serve - Remote Pump Style
225R	Single Barrel with Spinner - Shake - Remote Pump Style
238R	Twin Barrel with Twist - Soft Serve - Remote Pump Style

The above models include a 2 HP drive motor, with a 2.5 HP soft serve and 2.0 HP shake compressor. Self-contained freezers have 6.5 gallon (24.7 liter) hopper per side, with a Stoelting model 219 mix pump.

MODEL	WIDTH in/cm	DEPTH in/cm	HEIGHT in/cm	NET WT. lb/kg
217	15/38	39.25/99.5	64.25/163	405/183.7
217R	15/38	39.25/99.5	60.75/154.5	375/170.1
225R	15/38	39.25/99.5	60.75/154.5	385/174.5
238R	16/40.6	39.25/99.7	60.75/154.3	710/322

ELECTRICAL REQUIREMENTS:

- Domestic - 1 Phase, 230 volt or 3 phase, 208/230 volts, 60 hertz are available.
- Refer to electrical nameplate at the rear of the freezer for specific requirements.
 - Wiring diagram is in information packet located behind left side panel, or front header panel.

SECTION 2 INSTALLATION

2.1 SHIPMENT AND TRANSIT

The freezer has been assembled, operated, and inspected at the factory. For shipment, the freezer is placed on skids, with small parts placed separately in boxes. Upon arrival at the final destination, the freezer must be checked for any damage which may have occurred during final transit.

With the sturdy packaging used, the equipment should arrive in satisfactory condition. THE CARRIER IS RESPONSIBLE FOR ALL DAMAGE IN TRANSIT, WHETHER VISIBLE OR CONCEALED. Do not pay the freight bill until you have checked the equipment. Have the carrier note any visible damage on the freight bill. If concealed damage and or shortage is found later advise the carrier within ten days and request inspection. The customer must place claim for damage and/or shortages in shipment with the carrier. Stoelting, Inc. cannot make any claims against the carrier.

2.2 INSTALLATION

Installation of the freezer involves moving the freezer close to its permanent location, removing all protective packaging, setting in place and cleaning.

- A. Remove all protective packaging. Remove the hold down bolts from the wooden pallet, and walk freezer off the pallet.
- B. The freezer is shipped without legs. To install legs, lift freezer and screw caster, extension, or leg into the bottom of frame at each corner. Refer to caster and leg options in Figure 1.

Warning

FREEZER MUST NOT BE ALLOWED TO TIP MORE THAN 10°. FAILURE TO HEED THIS WARNING COULD RESULT IN THE FREEZER FALLING ON IT'S SIDE CAUSING SERIOUS DAMAGE OR INJURY.

- C. To level turn the top part of the caster or the bottom part of the leg in or out. Then level by placing a level on top of the freezer at each corner.

NOTE

Leveling is necessary for correct freezer drainage.

- D. For all freezers allow a minimum of 6 inches of space at the front and rear for air circulation. For efficient operation, the room temperature should not be low 60° F (16° C) or above 90° F (32° C).
- E. For water cooled freezers, install a minimum of 1/2 inch pipe or 5/8 inch inside diameter copper water line to the freezer. The water line must be connected in a manner that will comply with local codes and allow adequate room for servicing.

NOTE

All external plumbing is to be supplied by the customer. Water lines connect to fittings at the rear of the freezer. (See Fig.2) Connect the clean, potable, water inlet to water source using flexible high water pressure line. Ordinary garden hose is not recommended. Connect the water outlet to flexible plastic tubing. The outlet can be secured to floor drain, as the outlet is clean, warm water.

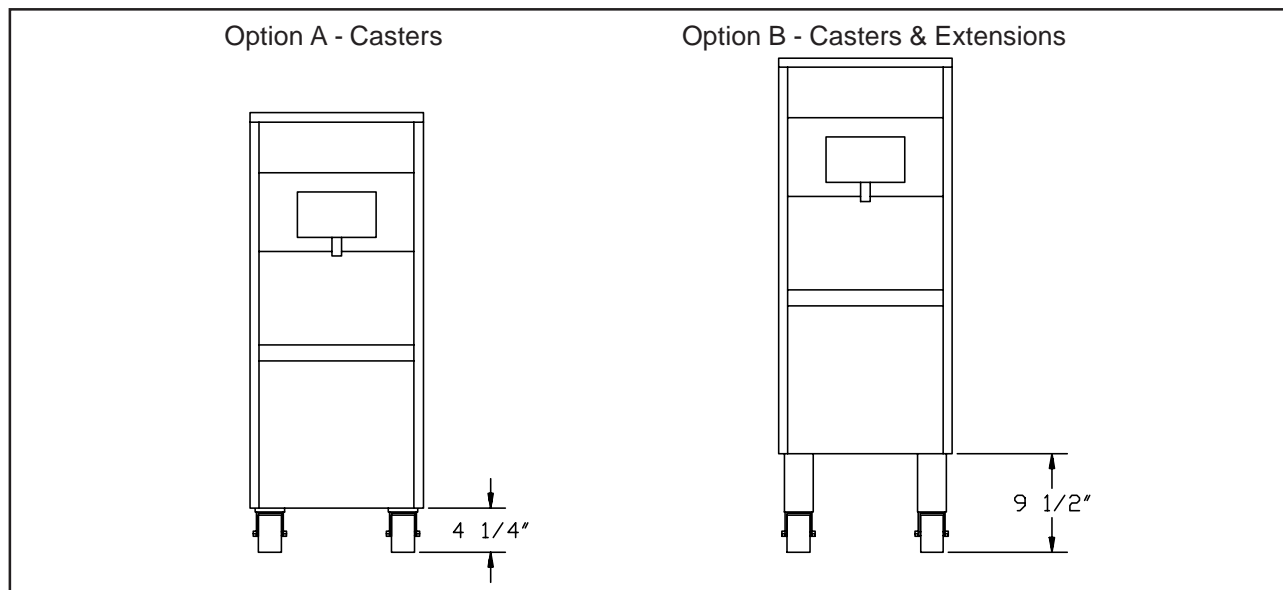

**Figure 1. Caster Options
For Models 217, 217R, 225R, 238R**



Figure 2
Water Connections

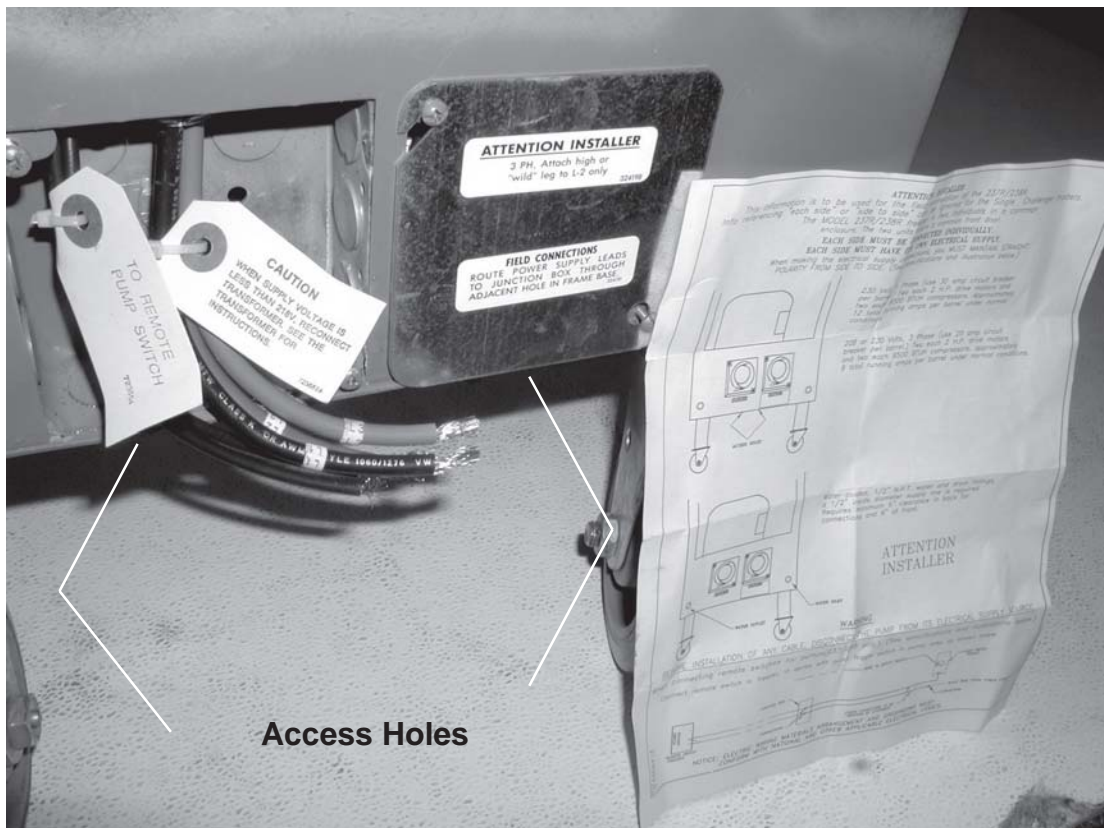

Figure 3
Electrical Connections



CAUTION

FLUSH ALL WATER LINES BEFORE INSTALLATION. IN NEW STORES WITH SEDIMENT IN WATER, ADD SUITABLE FILTER OR STRAINER TO WATER INLET. FAILURE TO FLUSH ALL WATER LINES MAY RESULT IN EQUIPMENT FAILURE AND EQUIPMENT DAMAGE.

- F. Refer to nameplate at the side of the freezer for specific electrical requirements. Connect electrical power to the junction box at the rear of the freezer. Bring wires into junction box through access hole in bottom rear of freezer. (Fig.3).

ATTENTION

The 24V AC pilot circuit is wired for a 240V supply. If this freezer is installed in a location with a 208V supply the transformer must be rewired. Remove the left and right side panel to access.



CAUTION

ELECTRICAL TECHNICIANS MUST BE CONTINUOUSLY ALERT TO THE PRACTICE OF ALL NECESSARY SAFETY RULES AND PRECAUTIONS WHEN SERVICING THIS EQUIPMENT AS VOLTAGES ARE PRESENT WHICH CAN CAUSE SERIOUS OR FATAL INJURY.

ELECTRICAL WIRING MATERIALS, ARRANGEMENT AND GROUNDING MUST CONFORM WITH NATIONAL AND OTHER APPLICABLE ELECTRICAL CODES.



**Figure 4
Auger Shaft Rotation**

- G. Check the auger shaft rotation by placing the MAIN DRIVE switch in the CLEAN position. Auger shaft rotation is clockwise as viewed through the clear plastic front door. If the rotation is not clockwise, turn main electrical power OFF. Then reverse any two electrical power lines in the junction box (three phase only). Recheck auger shaft rotation. (Fig.4)

NOTE

Three phase freezers in areas of unbalanced electrical loads require special attention when connecting input electrical power. The unbalanced leg of power (called wild or high) must be connected to L2 in the junction box.

- H. Remote fed freezers require an approved 1/2 inch (12.7 mm) I.D. refrigerated mix transfer tube from mix pump in walk in cooler to mix inlet at top of freezer. Clamp both ends of tubing. Support to prevent sagging and to promote total drainage when not in use.

NOTE

Refer to the mix pump manual for complete information on the operation of the mix pump.

2.3 REMOTE CONDENSER

The remote condenser can be installed either indoors or outdoors without additional protection required. Horizontal installation requires the liquid line connection to be made at the bottom of the coil. There should be no obstructions to the fan within five feet of the discharge.

NOTE

There must be an adequate supply of ambient air below 120° F (49° C). Operating above this temperature will result in loss of capacity. Guard against recirculation due to discharge into an overhang roof or the side of the building.

- A. Connect 230VAC, 60HZ, 1-PH to run the 1/6 HP, 2.8 AMP fan motor.
- B. Connect refrigerant lines. Use 3/8 inch (9.52 cm)O.D. copper line only. Trap hot gas line as shown (Fig.5). Do not trap liquid line at all. If condenser is below the freezer, no traps are required. (Fig.5)

NOTE

Maximum line length is 50 feet (15.24 meters).

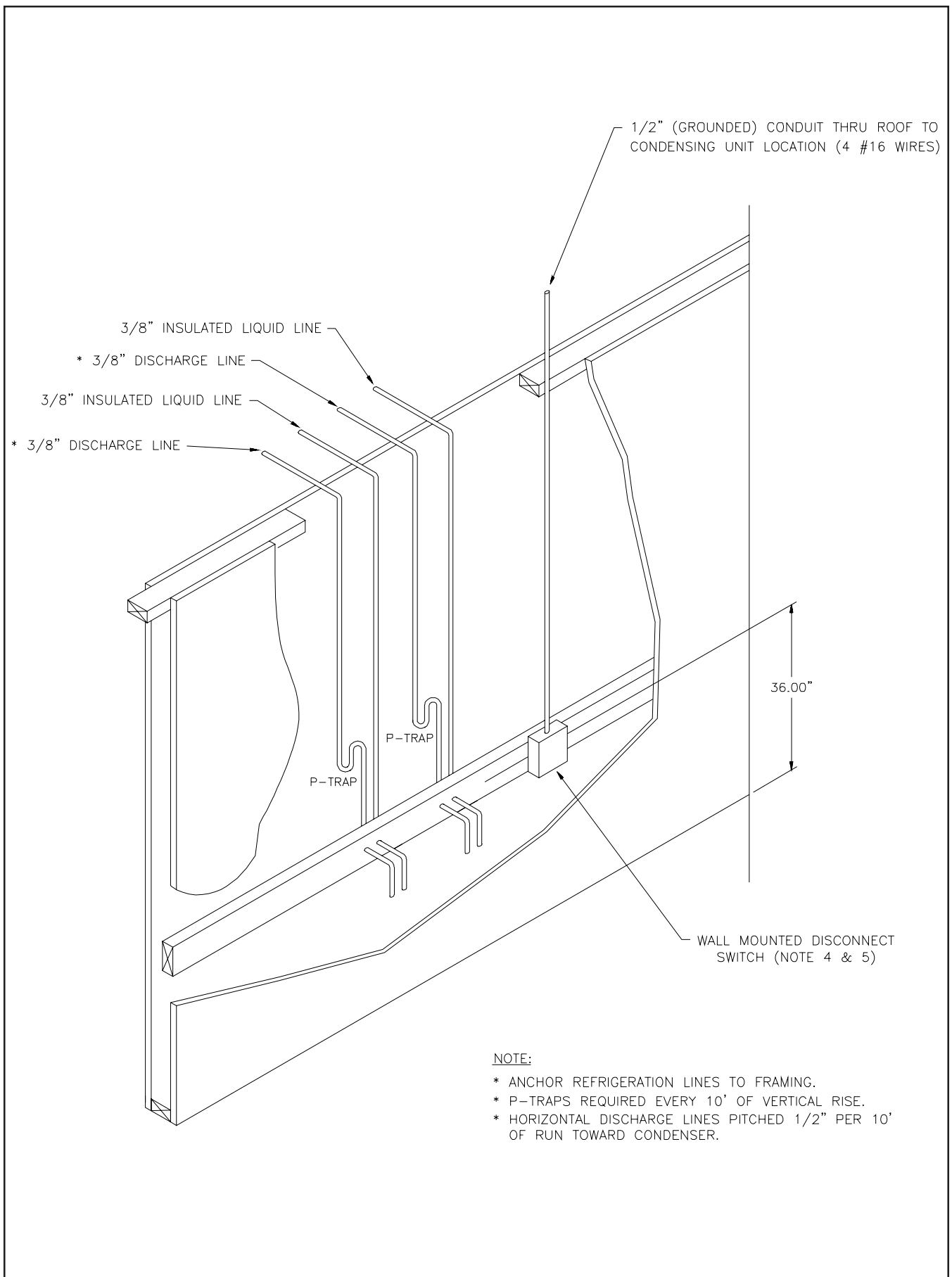

Figure 5
Remote Condenser

2.4 U3 MIX PUMP INSTALLATION AND CHECKOUT (REMOTE MODELS)

- A. Follow the steps below to install the mix pump in an upright position on the wall (allow clearance for a mix container under pump). See Fig.6.

1. Mount by locating four (4) hole centers on cooler wall using mounting bracket as template.

Caution

KNOW THE COOLER'S WALL DESIGN BEFORE DRILLING TO PREVENT PERSONAL INJURY OR PROPERTY DAMAGE.

2. Drill four (4) 1/2" diameter holes into cooler wall 3/4" deep.
 3. Insert well-nut to flange and apply silicone sealant around outside diameter of flange and cooler wall.
 4. Repeat steps 2&3 for other located hole centers.
 5. Mount bracket to cooler wall with supplied wing screws. Hand tighten until secure.
 6. Mount pump to bracket with wing nuts.
- B. Connect 1/2" (1.27cm) I.D. plastic food grade tubing to the mix container. Secure with hose clamps. (5/8" tubing is used with the 219 pump)
- C. Connect 1/2" (1.27 cm) I.D. plastic food grade tubing between the large port of air/mix tee and refrigerated mix transfer line. Secure with large hose clamp or equivalent.
- D. Plug mix pump into a 115 volt grounded receptacle.

National sanitation foundation compliance requirements (Remote Pump)

In order to comply with the "National Sanitation Testing Laboratory, Inc." (NSF)code #6:

- A. This unit (remote pump) must be installed with a "NSF" listed refrigerated mix transfer line. The mix transfer line must be pitched to the cooler with no sags or low points, to allow complete drainage.(Fig.6).
- B. The product at the mix pump and in transfer line must be maintained below 41° F (5.0° C).

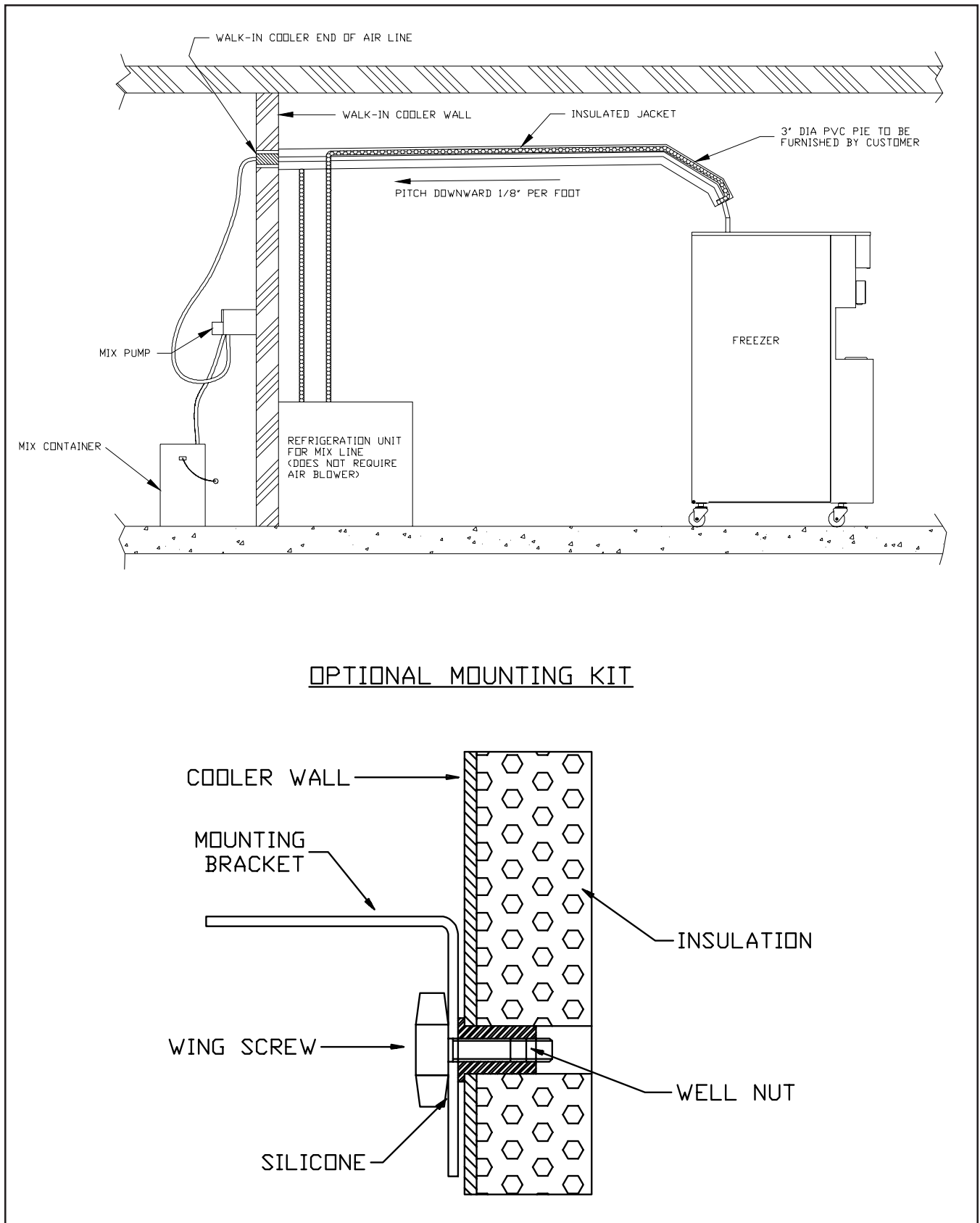

Figure 6
Mix Transfer Line
and Pump Installation

SECTION 3 OPERATING INSTRUCTIONS

3.1 Safety Information

WARNING Read and understand the entire manual before operating or maintaining Stoelting equipment.

This Owner's Manual provides the operator with information for the safe operation and maintenance of Stoelting equipment. As with any machine, there are hazards associated with their operation. For this reason safety is emphasized throughout the manual. To highlight specific safety information, the following safety definitions are provided to assist the reader.

The purpose of safety symbols is to attract your attention to possible dangers. The safety symbols, and their explanations, deserve your careful attention and understanding. The safety warnings do not by themselves eliminate any danger. The instructions or warnings they give are not substitutes for proper accident prevention measures.



SAFETY ALERT SYMBOL Indicates danger, warning or caution. Attention is required in order to avoid serious personal injury. The message that follows the symbol contains important information about safety.



DANGER indicates an imminently hazardous situation, which, if not avoided, will result in death or serious injury and equipment/property damage.



WARNING indicates a potentially hazardous situation, which, if not avoided, may result in death or serious injury and equipment/property damage.



CAUTION indicates a potentially hazardous situation, which, if not avoided, may result in minor or moderate injury and equipment/property damage.



CAUTION indicates a potentially hazardous situation, which, if not avoided, may result in equipment/property damage.



NOTICE indicates information or procedures that relate directly or indirectly to the safety or personnel or equipment/property.

Safety Labels

Take notice of all warning labels on the freezer (refer to Figure 7). The labels have been put there to help you maintain a safe working environment. The labels have been designed to withstand washing and cleaning. All labels must remain legible for the life of the freezer. Labels should be checked periodically to be sure they have not been damaged or removed and that they can be recognized as warning labels.

If you are in need of replacement labels, contact the authorized Stoelting distributor in your area.

3.2 SAFETY PRECAUTIONS

Do not attempt to operate the freezer until the safety precautions and operating instructions in the manual are read completely and are thoroughly understood.

SAFE OPERATION IS NO ACCIDENT; observe these rules:

- A. **Know the freezer.** Read and understand the operating instructions.
- B. **Notice all warning labels on the freezer.**
- C. **Wear proper clothing.** Avoid loose fitting garments, and remove watches, rings or jewelry which could cause a serious accident.
- D. **Maintain a clean work area.** Avoid accidents by cleaning the area and keeping it clean.
- E. **Stay alert at all times.** Know which switch, push button or control you are about to use and what effect it is going to have.
- F. **Disconnect electrical power for maintenance.** Never attempt to repair or perform maintenance on the freezer until the main electrical power has been disconnected.
- G. **Do not operate under unsafe operating conditions.** Never operate this freezer if unusual or excessive noise or vibration occurs.

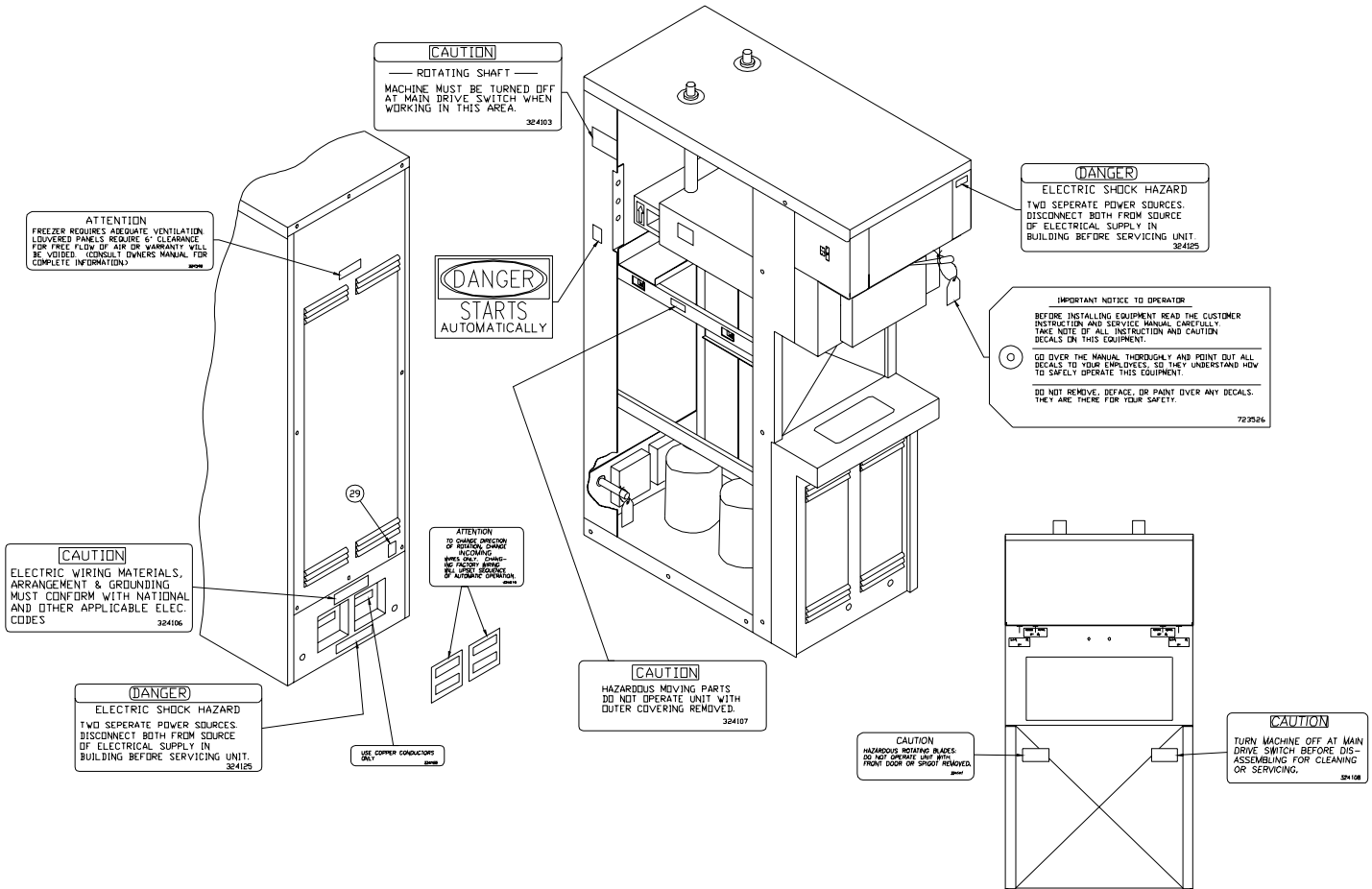

Figure 7
Warning Label Locations

3.3 OPERATING CONTROLS

It is required that the operator know the function of each control or component on the freezer before operating. Refer to Fig.8 for the location of the operating controls.

3.4 SPIGOT SWITCH

The SPIGOT SWITCH will automatically activate the auger drive and refrigeration system when the spigot switch is opened to draw product.

3.5 DRIVE MOTOR OVERLOAD

The internal DRIVE MOTOR OVERLOAD will trip if the drive motor is overloaded. It will reset after approximately 10-12 minutes. If the drive motor continues to trip, refer to troubleshooting.

3.6 POWER SWITCH (Clean-Off-Serve)

The POWER switch is a three-position toggle switch used to control the operation of the refrigeration system and auger. When the switch is placed in the CLEAN position, the refrigeration system will be off and the auger will rotate for cleaning.

When the switch is placed in the OFF position, the refrigeration system and the auger are inoperative. When the switch is placed in the SERVE position, the refrigeration system and auger will be controlled automatically. The switch must be placed in the SERVE position for normal operation.

3.7 FREEZING SWITCH

The FREEZING switch is a two-position toggle switch used to control the operation of the auger drive and refrigeration system. When the switch is placed in the MAXIMUM position, the freezer will continue to run for a minimum of 30 seconds after the spigot is closed. This time cycle provides make-up cooling periods of heavy dispensing. Heavy dispensing is drawing more than 18 ounces (.53 liters) in one minute.

When the switch is placed in the NORMAL position, the freezer will continue to run for a minimum of 5 seconds after the spigot is closed. This time cycle is to be used during periods of normal dispensing. Normal dispensing is drawing less than 18 ounce (.53 liters) in one minute.

NOTE

Do not leave the switch in the MAXIMUM position during slow or moderate dispensing as the product temperature will become too cold.

3.8 DOOR INTERLOCK SWITCH

When the door is securely fastened the freezer will operate normally. When the door is removed the drive and compressor will not run.

3.9 REMOTE PUMP SWITCH

The OFF-ON REMOTE PUMP SWITCH is a two-position switch. When wired in series with the model 219 or U3 REMOTE PUMP OFF, pump operation can be controlled from the front of the freezer. With the 219 or U3 REMOTE PUMP OFF-ON SWITCH in the ON position, place the OFF-ON pump switch in the ON position and the pump will start. Place the OFF-ON switch in the OFF position and the pump will stop.

3.10 DISPENSE RATE ADJUSTER

The dispense rate adjuster limits the opening of the spigot. To adjust product dispense rate, turn the adjusting knob clockwise for slower flow and counter-clockwise for faster flow.

3.11 HIGH PRESSURE CUT OUT

If the head pressure exceeds 405 PSIG the high head pressure cut out will trip. The reset button can be accessed from the lower front of the freezer.

3.12 SANITIZING PROCEDURES

For sanitizing to be effective, it must be performed after the mix pump and freezer parts have been cleaned, and just prior to filling the hopper or storage container with mix. Sanitizing the night before is not effective.

When sanitizing the freezer, refer to local sanitary regulations for applicable codes and recommended sanitizing products and procedures. The frequency of sanitizing must comply with local health regulations. Mix sanitizer according to manufacturer's instructions to provide a 100 parts per million strength solution. Mix sanitizer in quantities of no less than 2 gallons (7.5 liters) of 120° F water. Allow sanitizer to contact the surfaces to be sanitized for 5 minutes. Any sanitizer must be used only in accordance with the manufacturer's instructions.

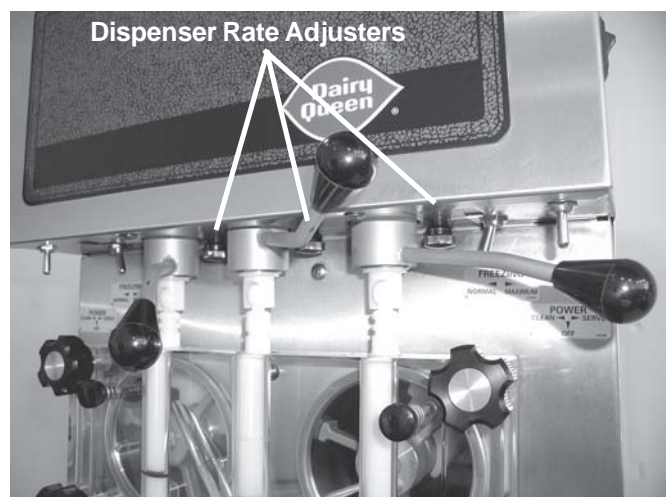
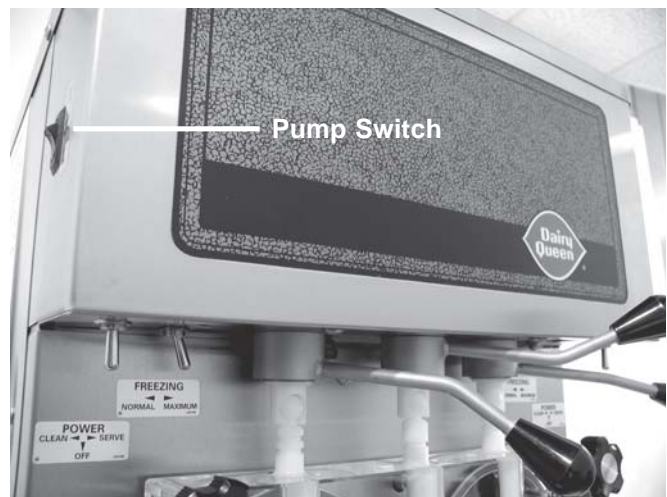

Figure 8. Operating Controls

NOTE

Stoelting has found that stera-sheen green label sanitizer and cleaner does an effective job of properly sanitizing and cleaning soft serve freezers. A sample is included with each new freezer. Read directions on packet, for more information. Other products may be as effective.

CAUTION

PROLONGED CONTACT OF SANITIZER WITH FREEZER MAY CAUSE CORROSION OF STAINLESS STEEL PARTS.

ANY DISINFECTANT MUST BE USED ONLY IN ACCORDANCE WITH THE MANUFACTURER'S INSTRUCTIONS. IN GENERAL, SANITIZING MAY BE CONDUCTED AS FOLLOWS:

- A. Clean and lubricate parts.
- B. Use a sanitizer mixed according to manufacturer's instructions to provide a 100 parts per million strength solution. Mix sanitizer in quantities of no less than 2 gallons (7.5 liters) of 120° F water. Allow the sanitizer to contact the surfaces to be sanitized for 5 minutes.



Figure 9. Air Bleed

Sanitizer must be used only in accordance with the manufacturer's instructions. Pour into hopper (hopper models) or storage container (remote models).

- C. Place the mix pump switch in the ON position and open air bleed valve on the front door by pushing valve in and holding. (See Fig.9)
- D. Let sanitizing solution fill the freezer barrel to air bleed valve, then close the valve by pulling out to lock in place.
- E. Place the MAIN DRIVE switch in the CLEAN position.

- F. Check for leaks at three points when the freezer barrel is first pressurized with sanitizing solution.
 - 1. Check for leaks at the plastic front door O-rings may not be sealing.
 - 2. Open access door on the side panel. Make sure the rear seal is not leaking.
 - 3. Check in the hopper (hopper models) to see that no bubbles are around the discharge end of the mix transfer tube.
- G. Using a sanitized soft bristle brush or equivalent, dipped in sanitizing solution, clean mix container (remote models) or sides of hopper, exterior of pump, and underside of hopper cover (hopper models).
- H. After five minutes, open spigot to expel sanitizing solution. Drain all solution from freezer.
- I. Close the spigot and place the mix pump switch and the POWER switch in the OFF position.

The freezer is now sanitized and ready for adding mix.

3.13 INITIAL FREEZE DOWN AND OPERATION

This section covers the recommended operating procedures to be followed for the safe operation of the freezer.

- A. Sanitize just prior to use according to instructions in section 3.11.
- B. Prepare the desired amount of mix and then fill hopper (hopper models) or storage container (remote models) with approximately three gallons (11 liters) or more of mix.

NOTE

Hopper models must not be filled to more than 2" (5 cm) from the top.

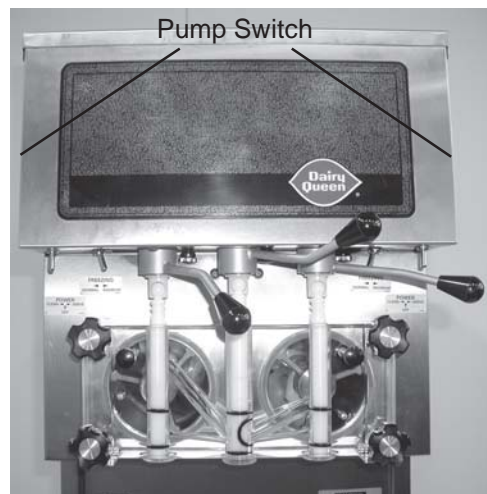

Figure 10. Pump Switch

- C. Place the mix pump switch, located on the mix pump, in the ON position. Immediately open the spigot and let approximately 8 ounces (.2 liters) of liquid mix with sanitizing solution, drain out of the spigot.

NOTE

Model 238R freezers have pump switches located on the side of the upper front panel. (See Fig.10)

- D. Close the spigot and open the air bleed valve on the front door by pushing the valve in and holding. Allow the barrel to fill until the mix level is 1/2 inch (12.7 mm) below air bleed valve, then release valve and pull closed to lock in place.
- E. Start the compressor and drive motor by placing the main drive switch in the SERVE position.
- F. The product will be ready to serve after the compressor has cycled on and off repeatedly **or** in approximately 12 minutes for soft serve and 30 minutes for shake.
- G. Soft serve refrigeration (217 and 238R) is automatically actuated when the spigot is opened. For normal dispensing, open the spigot no more than 90°. (This is when the handle knob is pointing directly away from the front door.) This position provides excellent control over the product and aids in making desired shaped portions. Close the spigot completely after dispensing.

1. The soft serve freezer is designed to dispense the product at the constant draw rate of one pint (.47 liters) every 37 seconds. This rate assumes the mix is supplied to the freezing cylinder at 41° F (5.0° C) or less and the product is dispensed at 17° F (-8.3° C) or higher, with a nominal overrun of 40%. A higher mix supply temperature, a lower product temperature, or a lower overrun will result in a reduced draw rate. Also, some mixes with a high water content will result in reduced draw rates.
2. It is possible to overdraw, if the dispense rate exceeds the freezer's designed freezing capacity for extended periods. **If the freezer is over drawn, the result will be a soft product and an air "popping" sound heard at the freezing cylinder.** During normal operation it is not necessary to be overly concerned about capacity. But if there is an order for six shakes at one time, each using 9 ounces (.26 liters) of product, it should be considered as 54 ounces (1.60 liters) of product. Approximately two minutes must be allowed for a drawing of this volume. Experienced operators will notice when the freezer is beginning to fall behind, and will slow down the rate of draw so as not to exceed the capacity.

- H. Shake refrigeration (Model 225R) is automatically actuated when the spigot is opened. To start the spinner rotating, you must depress the foot pedal (some models). When dispensing a product, open the spigot fully, quickly and completely, filling the cup in one operation. **Slow dispensing, or progressively filling the cup in several steps, may result in undesirable reduction in product temperature.** After dispensing a product, the freezer will run for 5-20 seconds to freeze new product that has entered the barrel.

1. The shake freezer is designed to dispense the product at a constant draw rate of one pint (.47 liters) every 19 seconds. This rate assumes the mix is supplied to the freezing cylinder at 41° F (5.0° C) or less and the product is dispensed at 27° F (-3.3° C) or higher, with a nominal overrun of 50-55%. A higher mix supply temperature, a lower product temperature, or a lower overrun will result in a reduced draw rate.
2. It is possible to overdraw, if rate is exceeded for extended periods. **If the freezer is overdrawn, the result will be a soft product and an air "popping" sound heard at the freezing cylinder.** During normal operation it is not necessary to be overly concerned about capacity. But if there is an order for six shakes at one time, each using 9 ounces (.26 liters) of product, it should be considered as 54 ounces (1.60 liters) of product. Experienced operators will notice when the freezer is beginning to fall behind, and will slow down the rate of draw so as not to exceed the capacity.

- I. Air-cooled, self-contained shake and soft serve freezers are designed to operate in 90° F (32° C) maximum ambient air temperature. Higher temperatures will result in reduced capacity.
- J. On hopper models, when the float in the liquid level indicator is all the way down, there is approximately two gallons (7.57 liters) of mix left in the hopper. If mix runs out, excessive overrun will result in air pops and unsalable product. Keep the hopper full at night to aid in proper cooling.

3.14 REMOVING MIX FROM THE FREEZER

This cleaning procedure must be followed each time the freezer is to be shut off for an extended period such as overnight or on non-business days.

- A. Place the mix pump in the OFF position. Pull pickup hose from mix source.
- B. Draw desired frozen mix from freezer. Close spigot.
- C. Place POWER switch in CLEAN position. (20 minutes maximum)

Allow the mix to agitate in freezer barrel until the mix has become a liquid.

- D. Place the mix pump in the ON position. Open spigot and pump liquid mix through the freezer. When empty, place main drive switch and the mix pump switches in the OFF position.
- E. Close spigot and fill hopper (hopper models) with approximately two gallons of cold tap water.

NOTE

On remote models, place mix pump suction tube into the pail of cold tap water.

- F. Open air bleed valve on the front door by pushing valve in and holding.
- G. Place the mix pump switch in the ON position.
- H. Let the cold water fill freezer to air bleed valve, then close the valve by pulling out to lock in place.
- I. Place the main drive switch in the CLEAN position.
- J. Allow water to agitate until the inside surface of front door has rinsed clean.

- K. Open spigot to expel water. When the hopper or pail is empty, place the mix pump switch and main drive switch in the OFF position. Allow freezer barrel to drain completely.
- L. Repeat steps E-K using mild detergent solution.
- M. Repeat steps E-K using 120 to 130° F (49-54° C) hot rinse water.

3.15 DISASSEMBLY AND ASSEMBLY OF FRONT DOOR (MODEL 217 AND 237R)

To aid in the disassembly of the front door, refer to Figure 11 and the following steps:

CAUTION
TURN FREEZER OFF AT MAIN DRIVE SWITCH BEFORE DISASSEMBLING FOR CLEANING OR SERVICING.

A. Disassembly of front door.

- 1. Remove the front door by unscrewing the black knobs.

CAUTION
HAZARDOUS ROTATING BLADES-DO NOT OPERATE UNIT WITH FRONT DOOR OR SPIGOT REMOVED.

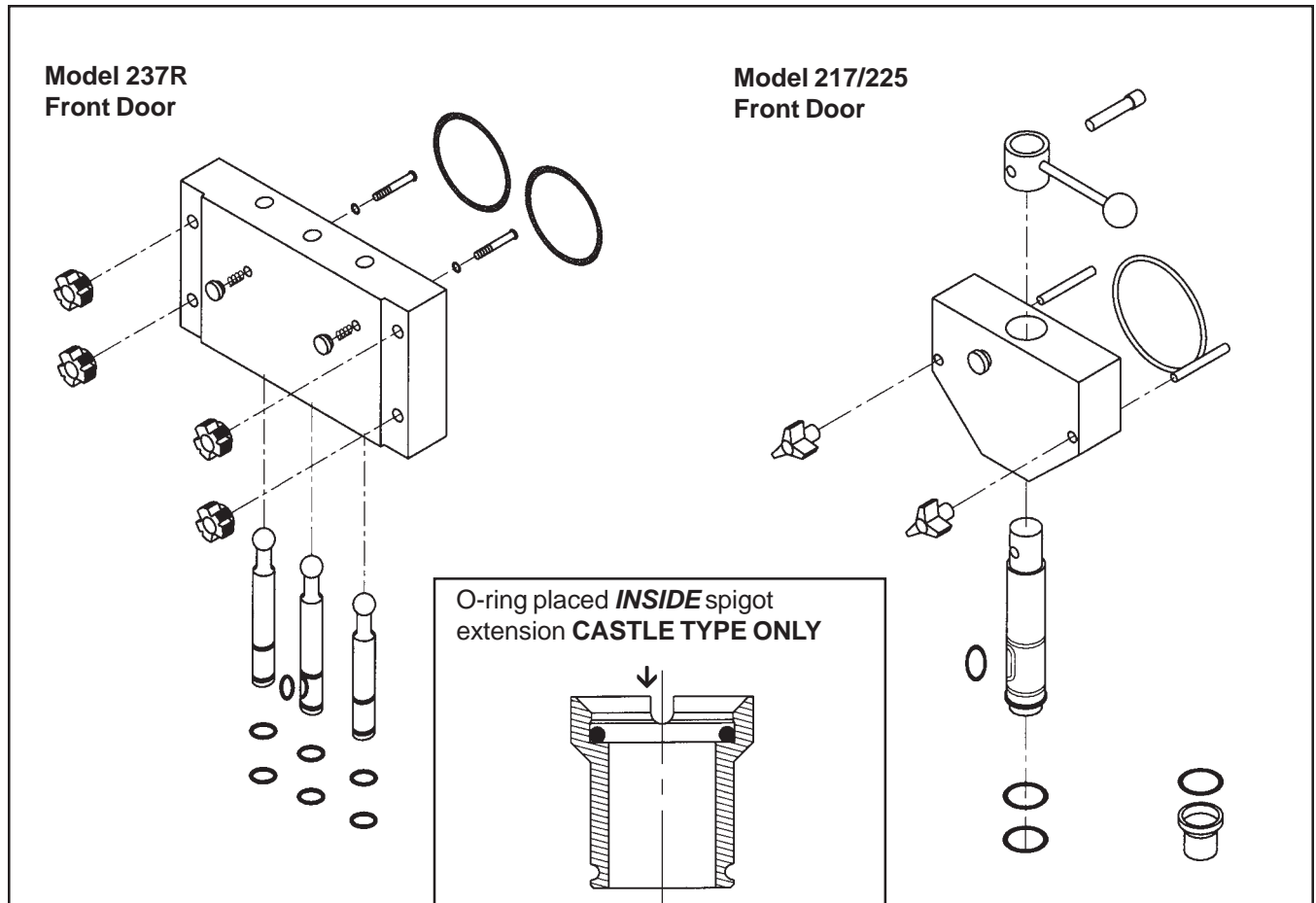

Figure 11
Front Door Disassembly

2. Remove the air bleed valve by unscrewing the knob while holding the valve stem from behind. Remove the compression spring and push air bleed valve through the rear of the front door.
3. Pull lock pin out of spigot handle, then remove spigot handle (217/225). Remove the spigot from the bottom of the front door.
4. Remove the door seal O-ring, air bleed valve o-ring, and spigot O-rings. Section 3.15 describes the correct procedure for O-ring removal, identification, and care.

B. Assembly of front door

NOTE

Petrol-gel sanitary lubricant or equivalent must be used when lubrication of parts is specified.

1. Assemble O-rings onto the spigot and extension dry (without lubrication). Then apply a thin film of sanitary lubricant to the outside of the O-rings and spigot bodies.
2. Install the spigots through the bottom of the front door. Groove in center spigot must line up with stainless steel pin (237R).
3. Install the spigot handles onto the spigots. Be sure red dots on spigots and dots on spigot handles are lined up before installing lock pins (217/225).
4. Assemble the air bleed valve O-ring onto the air bleed valves. Position the O-ring in the groove close to the wide part. Apply a thin film of sanitary lubricant to the O-rings.

5. Insert the air bleed valves from the back of the front door. Install compression springs onto air bleed valves, then screw on knobs finger tight.
6. Apply a thin film of sanitary lubricant to the door seal O-rings, and fit into the grooves on the rear of the front door.
7. Before installing front door onto freezer, turn spigots to open position. This step will eliminate any interference between the lock pins (on door) and spigot switch levers (217/225 only).
8. Place the front door assembly on the mounting studs and push front door against the freezer carefully.

NOTE

Position the front door support on auger so legs do not interfere with the pin on the back of the front door assembly. Front door must push auger in slightly when it is being tightened to prevent the rear seal from leaking.

9. Secure front door assembly by placing the knobs on the studs and alternately tightening opposite corners until finger tight only. Do not overtighten. Proper O-ring seal can be observed through the transparent front door.
10. Move the spigot handles to the closed position. (217/225)
11. On the model 225, you must first remove the spinner guard assembly (Model 225R) by removing the two black knobs and pulling the spinner guard off the freezer. Remove the spinner by removing and pulling spinner down. (Fig.12)

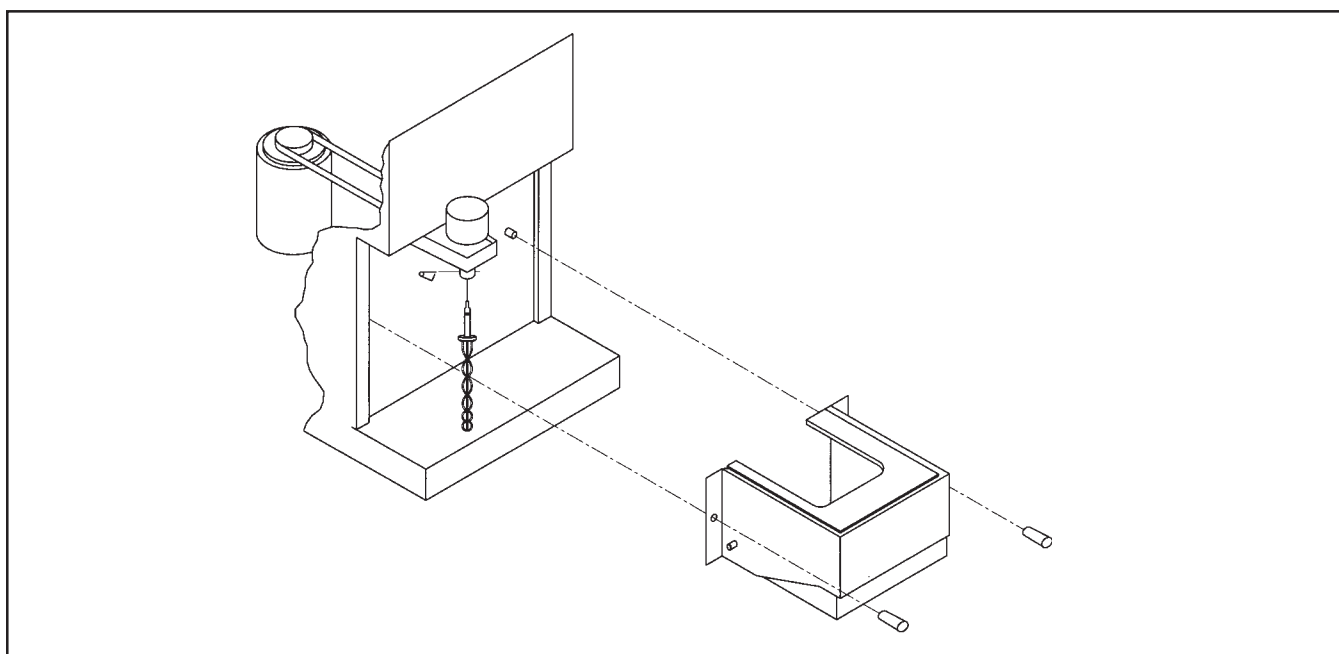

Figure 12. Spinner Assembly



Figure 13. Auger with Rubber Rear Seal

3.16 DISASSEMBLY AND ASSEMBLY OF AUGER

To aid in the disassembly and assembly of the auger, refer to Figure 13 in the following steps:

CAUTION
TURN FREEZER OFF AT MAIN DRIVE SWITCH BEFORE DISASSEMBLING FOR CLEANING AND SERVICING.

A. Disassembly of auger

1. Remove the front auger support by pulling it straight out of the freezer barrel.
2. Remove the plastic bearing from the front auger support.
3. Remove the auger by pulling slowly and rotating out of the freezer barrel. As the auger is with drawn, remove each plastic flight and spring from the auger. (Fig.14)

NOTE

Be careful not to scratch inside of the freezer barrel when removing flights or augers.



Figure 14. Auger Disassembly

4. Keep the rear of the auger tipped up once it is clear of the freezer barrel. This prevents the auger seal from falling off.
5. Wipe spline lubricant off hex end rear of auger with a paper towel.

6. Remove the rear seal assembly.
7. After proper cleaning, inspect plastic parts and rear seal parts for wear and damage. (See Fig. 15)

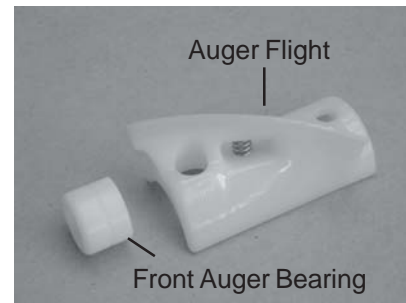

Figure 15. Plastic Parts

B. Assembly of Auger

NOTE

Petro-Gel sanitary lubricant or equivalent must be used when lubrication of parts is specified.

1. Install O-ring onto auger shaft dry (without lubrication).
2. Lubricate the O-ring and the inside of the rear seal adapter with a thin film of sanitary lubricant.
3. Install the rear seal adapter and seal in order as shown in Figure 16.



Figure 16. Auger Assembly

4. Lubricate the hex drive end of auger with a small amount of white spline lubricant.

NOTE

A small container of socket lubricant is shipped with the freezer.

5. Turn springs into the plastic flights (See Fig.17). Install first flight to bottom of auger, rotate, add successive flights from bottom as the auger is pushed slowly into the freezer barrel. Carefully engage auger with drive socket in speed reducer by rotating auger slowly and pushing on end of auger. The front door will push auger into its final position when the door is tightened down.

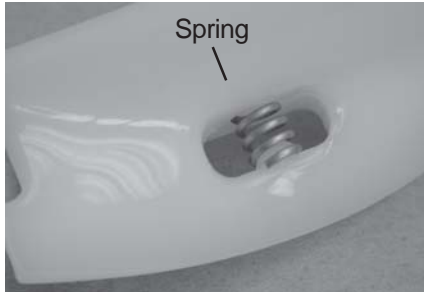

Figure 17. Auger Flight Spring

6. Apply a thin film of sanitary lubricant to the inside and outside of the front auger support bearing, then place on the front of the auger. Assemble the front support on the auger over the front bearing.

3.17 DISASSEMBLY AND ASSEMBLY OF MIX LINE ADAPTER (REMOTE MODELS)

To aid in the disassembly and assembly of the mix line adaptor, refer to Figure 18 in the following steps:



Figure 18. Mix Line Adapter

NOTE

Relieve pressure before disassembly. Place mix pump OFF and main drive switch in the CLEAN position. Open spigot and operate until mix does not dispense.

A. Disassembly of Mix Line Adaptor

1. Remove the mix line adaptor by pulling clip and lifting adaptor straight out.
2. Remove the O-rings for cleaning. Section 3.15 describes the correct procedure for O-ring removal, identification and care.

B. Assembly of Mix Line Adaptor

1. On remote pump freezers, assemble O-rings and install mix line adaptor. Apply sanitary lubricant to the outside of O-rings.

3.18 O-RING REMOVAL AND CARE

Worn or damaged o-ring seals must be replaced to insure proper operation. To prevent undue damage to these seals, be sure to apply lubricant where required and avoid twisting O-rings during assembly. Worn or damaged O-rings or twisted O-rings will cause air and/or mix leakage.

To remove O-rings from parts for cleaning or servicing, refer to Fig. 19 and follow the following steps:

- A. Remove all lubricant from O-ring using a clean paper towel.
- B. Remove O-ring by squeezing upward with a dry cloth as shown in Fig. 19. When a loop is formed, use your other hand and roll the O-ring out of the groove.



Figure 19. Removing O-rings

NOTE

Do not use any type of sharp object to remove O-ring.

3.19 CLEANING OF FREEZER AND FREEZER PARTS

A high quality grade of stainless steel has been used on the freezer to ease clean-up. To remove spilled or dried mix from the exterior, simply wash in warm, soapy water and wipe dry. The use of soft water is recommended. Do not use highly abrasive materials as they will mar the finish.

- A. To clean the freezer parts, disassemble all parts. (Refer to Sec. 3.11 - 3.17 for the disassembly of freezer parts.)
- B. Place all parts in warm, mild detergent water and wash thoroughly. Rinse all parts with clean, hot water. The use of soft water is recommended, along with dishwashing detergents such as Joy, Dawn, or equivalent.

NOTE

Take care not to damage parts by dropping or rough handling.

- C. Wash hopper (hopper models), feed tube (remote models), and freezer barrel with warm detergent water and brushes provided. Rinse with clean, hot water.

NOTE

On remote models, feed tube must be cleaned from top and from the inside of the barrel, using the 1-1/2" x 30" brush provided.

- D. Clean the rear seal surface from the inside of the freezer barrel.
- E. Remove the rear drip tray by opening access door on side panel. Clean and replace drip tray.

3.20 SANITIZE FREEZER PARTS

- A. Use a sanitizer mixed according to manufacturer's instructions to provide a 100 parts per million strength solution. Mix sanitizer in quantities of no less than 2 gallons (7.5 liters) of 120°F water. Allow the sanitizer to contact the surfaces to be sanitized for 5 minutes. Any sanitizer must be used only in accordance with the manufacturer's instructions.
- B. Place all parts in the sanitizing solution, then remove and let air dry.
- C. Assemble freezer parts. (Refer to Sections 3.12B - 3.13B for the assembly of freezer parts.)

NOTE

Any cleaning procedure must always be followed by sanitizing the assembled freezer before filling with mix.

SECTION 4 MAINTENANCE INSTRUCTIONS

4.1 FREEZER ADJUSTMENT

This section is intended to provide maintenance personnel with a general understanding of the freezer adjustments. It is recommended that any adjustments in this section be made by a qualified person.

4.2 PRODUCT TEMPERATURE ADJUSTMENT

A potentiometer is used to control the product temperature. To change the temperature of the product, follow the steps below:

- A. Remove the two screws under each corner of the header display sign, then pull sign out and down.

NOTE

Removal of inside electrical box cover (if present) is not necessary when making temperature adjustments.

- B. Use a screw driver to make desired adjustment. A label near the potentiometer will give complete instructions. (See Fig. 20)

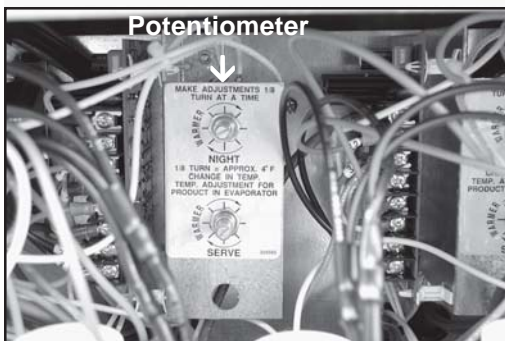

Figure 20. Potentiometer

4.3 DRIVE BELT TENSION ADJUSTMENT

To check belt tension, refer to Figure 21 and follow the steps below:

⚠ WARNING

Disconnect all electric power before servicing. Follow proper lockout/tagout procedures to ensure the power cannot be inadvertently energized. Failure to disconnect power before servicing could result in death or serious injury.

⚠ WARNING

Moving belts and pulleys can crush and dismember. Do not operate machine with cabinet panels removed.

- A. Remove either side panel.
- B. Press firmly on one belt. (See Figure 21)
- C. When the tension is properly adjusted, the outside of the depressed belt should be approximately in line with the inside of the other belt.



Figure 21. Belt Adjustment (Model 237 Shown)

- D. If an adjustment is necessary, loosen jam nut on motor adjustment plate. Then tighten or loosen adjusting nut for proper tension and tighten jam nut. On Model 238R you must loosen the four motor plate retaining nuts.

NOTE

Belt life will be increased if new drive belts are tightened after two or three weeks of operation.

4.4 CONDENSER CLEANING AIR-COOLED FREEZERS)

⚠ CAUTION

Hearing Protection Required!

This procedure emits a loud noise. Wear proper hearing protection. Failure to wear proper hearing protection may result in permanent hearing loss.

The condenser requires periodic cleaning. To clean the condenser, refer to the following steps:

NOTE

Some freezers have a condenser filter. To clean, remove and wash in warm soapy water. Rinse in clean water and shake dry, taking care not to damage filter in any way.

- A. Visually inspect the condenser for dirt. (Remove front panel on self-contained freezers.)
- B. If the condenser is dirty, place a wet towel over the front of the condenser.
- C. Using compressed air or CO2 tank, blow out the dirt from the back of the condenser. Most of the dirt will cling to the wet towel.

- D. An alternative method is to clean with a condenser brush and vacuum.

NOTE

If the condenser is not kept clean, loss of refrigeration efficiency will result.

4.5 PREVENTATIVE MAINTENANCE

It is recommended that a preventative maintenance schedule be followed to keep the freezer clean and operating properly. The following steps are suggested as a preventative maintenance guide.

 **WARNING**

High voltage will shock, burn or cause death. Turn off and lock out main power disconnect before servicing. Do not operate machine with cabinet panels removed.

The United States Department of Agriculture and the Food and Drug Administration require that lubricants used in food zones be certified for this use. Use lubricants only in accordance with the manufacturer's instructions.

A. Daily Checks

Check for any unusual noise or condition and repair immediately.

B. Month Checks

 **WARNING**

Moving belts and pulleys can crush and dismember. Do not operate machine with cabinet panels removed.

1. Check drive belts for wear and tighten belts if necessary. (Refer to Section 4.3)
2. Check the condenser for dirt. (Refer to Section 4.4)

 **WARNING**

Hazardous Voltage

Disconnect all electric power before servicing. Follow proper lockout/tagout procedures to ensure the power cannot be inadvertently energized. Failure to disconnect power before servicing could result in death or serious injury.

4.6 EXTENDED STORAGE

Refer to the following steps for winterizing the freezer or for storing the freezer over any long period of shutdown time.

- A. Clean thoroughly with warm detergent all parts that come in contact with mix. Rinse in clear water and dry all parts. Do not sanitize.

NOTE

Do not let cleaning solution stand in freezer barrel, hopper pan, or mix pump during the shutdown period.

- B. Remove, disassembly, and clean the front door, auger shaft, and mix pump. Leave disassembled during the shutdown period.
- C. Place plastic auger flights in a plastic bag with a moist paper towel. This will prevent flights from becoming brittle if exposed to dry air over an extended period of time (over 30 days).

 **CAUTION**

Hearing Protection Required!

This procedure emits a loud noise. Wear proper hearing protection. Failure to wear proper hearing protection may result in permanent hearing loss.

- D. For water-cooled freezers that are left in unheated buildings, or buildings subject to freezing, the water must be shut off and disconnected. Disconnect fittings at water valve inlet and water outlet lines at frame. The fittings are located at the rear of the freezer. Run the compressor for 2 - 3 minutes to open water valve. Blow out all water, first through water inlet, then through water outlet lines with air or carbon dioxide. Also drain water supply line to the freezer.
- E. Place the mix pump ON-OFF switch, and the POWER switch in the OFF position.
- F. Disconnect from the source of input of electrical supply in the building.

4.7 TROUBLESHOOTING

The Troubleshooting Table lists the common problems that can occur to the freezer.

PROBLEM	POSSIBLE CAUSE	REMEDY
Drive motor (auger) "kicks-out", or does not run.	<ol style="list-style-type: none"> 1. Power to freezer is off. 2. Drive motor overloaded. 3. Low line voltage. 4. Product too hard. 5. Front door not installed securely. 	<ol style="list-style-type: none"> 1. Check power to freezer. 2. Wait 15-20 min. for motor to reset. 3. Check, must be +/-10% of nameplate voltage. 4. Raise overrun (see pump manual) and/or product temperature. (See Sec. 4.2) 5. Install front door securely.
Compressor does not operate.	<ol style="list-style-type: none"> 1. Power to freezer if off. 2. Drive motor overloaded. 3. Low line voltage. 4. Compressor internal overload is cut-out. 5. Front door not installed securely. 	<ol style="list-style-type: none"> 1. Check power to freezer. 2. Push DRIVE RESET lever. 3. Check, must be +/-10% of nameplate voltage. 4. Check condenser (air cooled)(See Sec. 4.4), or water supply (water cooled). 5. Install front door securely.
Product too soft.	<ol style="list-style-type: none"> 1. Temperature setting is too high. 2. Product break down. 3. Standby/Serve Switch in Standby position. 	<ol style="list-style-type: none"> 1. Adjust temperature. (See Section 4.2) 2. Fill with fresh product. 3. Place Standby/Serve Switch in Standby position.
Freeze-up. (Product will not dispense easily.)	<ol style="list-style-type: none"> 1. Temperature setting is too low. 2. Low overrun setting. 3. Low pump pressure. 4. Large air pocket in barrel. 5. Auger turning counter-clockwise. 	<ol style="list-style-type: none"> 1. Adjust temperature. (See Sec.4.2) 2. Raise overrun. (See pump manual) 3. Check pump pressure. 4. Purge air from barrel. 5. Change rotation to clockwise.
Rear auger seal leaks.	<ol style="list-style-type: none"> 1. Rear auger seal not lubricated. 2. Seal missing or installed wrong. 3. Worn or scratched shaft. 	<ol style="list-style-type: none"> 1. Lubricate seal. (See Sec. 3.14B) 2. Check. (See Sec. 3.14B) 3. Replace shaft.
Spigot leaks.	<ol style="list-style-type: none"> 1. Spigot parts are not lubricated. 2. Chipped or worn o-rings. 3. O-rings on spigot installed wrong. 4. Nicks or scratched on front door where spigot is located. 	<ol style="list-style-type: none"> 1. Lubricate. (See Sec. 3.12B) 2. Replace o-rings. 3. Remove spigot and check o-rings. 4. Replace front door.
Drive belts slipping or squealing.	<ol style="list-style-type: none"> 1. Drive belt tension not correct. 2. Worn belt(s). 3. Temperature setting is too low. 4. Low overrun. 	<ol style="list-style-type: none"> 1. Adjust belt tension. (See Sec. 4.3) 2. Replace belts. 3. Adjust temperature. (See Sec. 4.2) 4. Check for air leak.
Hopper mix temperature too warm.	<ol style="list-style-type: none"> 1. System low on refrigerant. 2. Mix level in hopper is too low. 3. EPR valve set too warm. 	<ol style="list-style-type: none"> 1. Add refrigerant. (Refrigeration Service) 2. Keep hopper 1/3 to 1/2 full of mix. 3. Remove side panel and locate EPR valve. Loosen locknut and turn screw CCW 1/4 turn. Retighten locknut. Check hopper mix temperature after one hour. Adjust another 1/4 turn if necessary.
Hopper mix temperature too cold. (sides frozen)	<ol style="list-style-type: none"> 1. EPR valve set too cold. 	<ol style="list-style-type: none"> 1. Remove side panel and locate EPR valve. Loosen locknut and turn screw CW1/4 turn. Retighten locknut. Check hopper mix temperature after one hour. Adjust another 1/4 turn if necessary.
Mix pump does not run properly.	<ol style="list-style-type: none"> 1. Mix pump problem. 	<ol style="list-style-type: none"> 1. See mix pump manual.

SECTION 5 HOW TO ORDER REPLACEMENT PARTS

5.1 HOW TO ORDER REPLACEMENT PARTS

To assure the receipt of the proper replacement parts, supply your serviceperson with the following information:

- A. Model number of equipment.
- B. Serial number of model (stamped on nameplate).
- C. Part number, part name, and quantity needed.

NOTE

Minimum billing is \$50.00 Net.

5.2 PARTS LIST AND REFERENCE DRAWINGS

The following lists and drawings will aid the user when ordering parts or servicing.

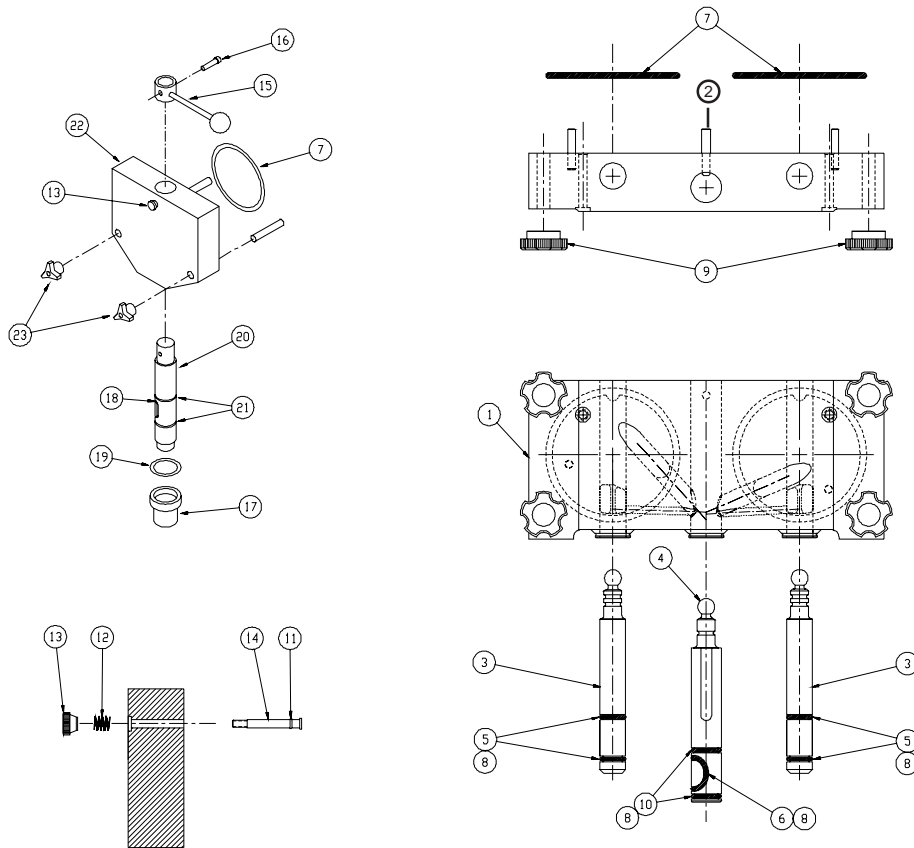

FRONT DOOR PARTS 217, 225 (Ser. #7806 Plus), Model 238 (Ser. #8615 Plus)

<u>Drawing Index No.</u>	<u>Part No.</u>	<u>Quantity</u>		<u>Description</u>
		<u>217/225</u>	<u>238</u>	
1	2177427		1	Front Door w/Pins
2	1158091		1	Actuator, Door Safety
3	3159696		2	Spigot, Outside
4	3158086		1	Spigot, Center
5	624598		4	O-ring
6	624664		1	O-ring
7	625133	1	2	O-ring, Front Door
8	508135			Lubricant, Petro-Gel
9	482019		4	Knob, Front Door
10	624614		2	O-ring
11	624520	1	2	O-ring, Air Bleed Valve
12	694200	1	2	Spring, Air Bleed Valve
13	482004	1	2	Knob, Air Bleed, Black
14	2110116	1	2	Stem, Air Bleed Valve
15	1107123	1		Spigot Handle
16	570998	1		Retaining Pin
17	2146293	1		Spigot Extension, 2" (217,225)
18	624655	1		Spigot O-ring
19	624645	1		Spigot Extension O-ring
20	3152581	1		Spigot, White (217, 225)
21	624677	2		Spigot O-ring
22	1143021-02	1		Front Door (217,225)
23	482035	2		Knob, Black

Parts Not Shown

624677	O-ring, Spigot Extension (238)	2157892	Spigot Extension - 1.5" (217,225)
2177072	Spigot Extension - 1.5" (238)	2159688	Spigot Extension - 2.5" (217,225)
2177073	Spigot Extension - 2.5" (238)	2143024	Spigot Extension - 3" (217,225)
2177074	Spigot Extension - 3" (238)	232732	Rosette Cap

NOTE

If you are replacing a front door without side grooves you must order the extensions and rosettes also.

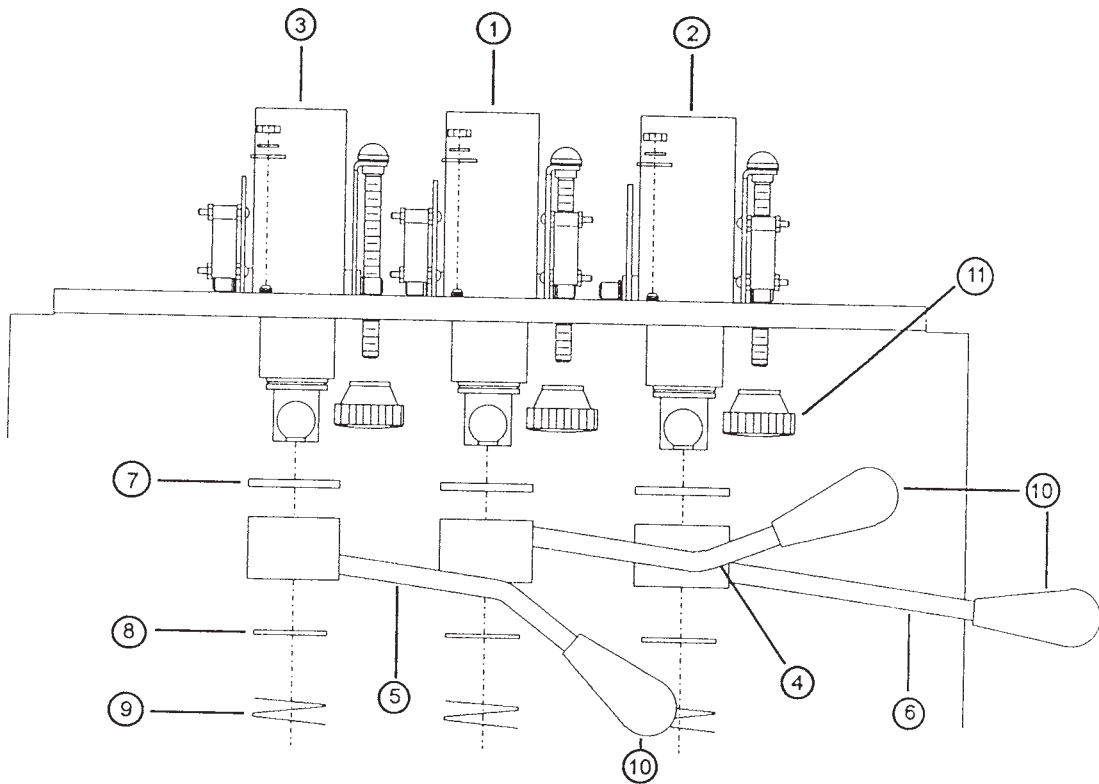

238 SPIGOT BREAKDOWN (Ser. #7124 Plus)

Drawing Index No.	Part Number	Qty.	Description
1	3156992	1	Cam Assy. Center
2	3157854	1	Cam Assy. Right
3	3157855	1	Cam Assy. Left
4	2156997	1	Handle, Center
5	2156999	1	Handle, Left
6	2157850	1	Handle, Right
7	221619	3	Bushing, Spacer
8	1154703	3	Washer
9	625440	3	Ring, Retaining 1.00" Dia.
10	482039	3	Knob, Handle
11	482004	3	Knob, Spigot Body Adjustment

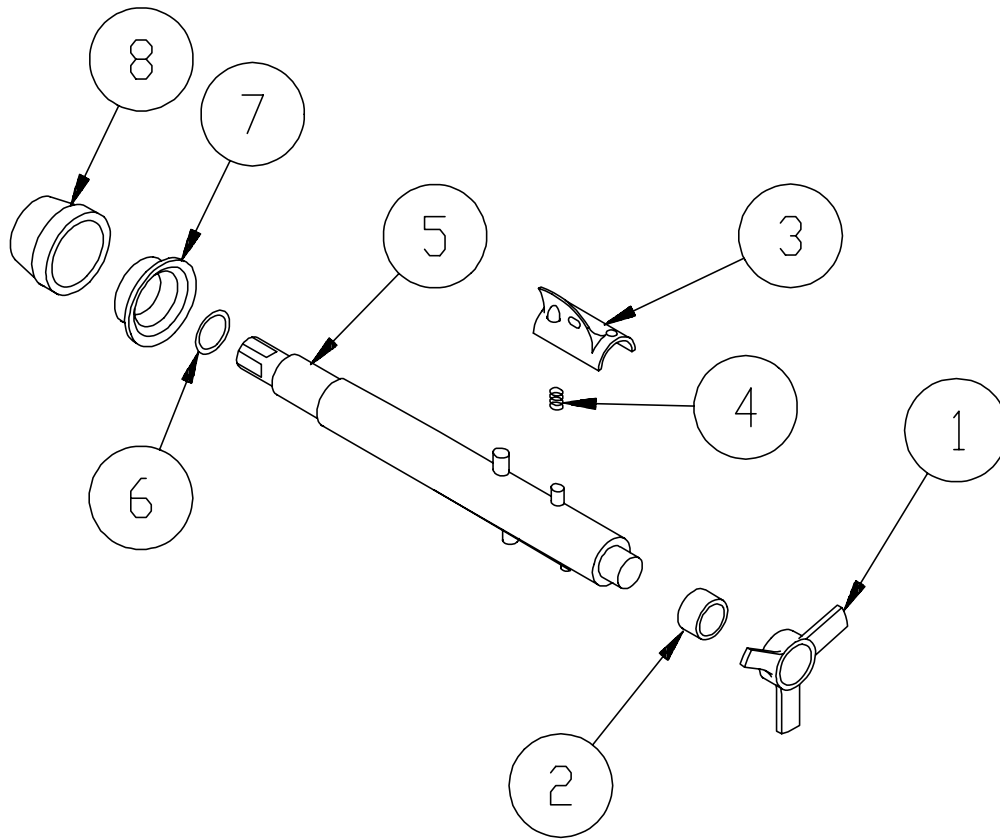

AUGER PARTS

Drawing Index No.	Part Number	Qty.	Description
1	2104552	1	Front Auger Support
2	149003	1	Front Auger Support Bushing
3	381804	2	Auger Flight
4	694255	2	Spring
5	4151178	1	Auger Shaft
6	624678	1	Rear Seal O-ring
7	1151859	1	Rear Seal Adaptor
8	667868	1	Rear Auger Seal

SPINNER PARTS (225 - Shake 227)

Drawing Index No.	Part Number	Qty.	Description
1	482039	2	Black Knob (Shake Guard)
2	3120092	1	Spinner Guard
3	2120090	1	Spinner Swing Shield
4	2132222	1	Top Splash Cover Insert
5	696146	1	Spring Clip
6	3143866	1	Spinner
7	624535	1	O-ring
8	653035	1	Thumb Screw (Belt Guard)
9	2143042	1	Left Belt Guard
10	2143041	1	Right Belt Guard
11	2119118	1	Spinner Bearing w/Bracket
12	599102	1	Pulley
13	150914	1	Spinner V-Belt (Ser.#0-7805)
14	(See Motor Nameplate)	1	Spinner Motor

PARTS NOT SHOWN

15	1110127	2	Hinge Pin - Swing Shield
16	1113185	2	Hinge Pin Retainer - Swing Shield
17	1130236	1	Delrin Pin - Top Splash Cover

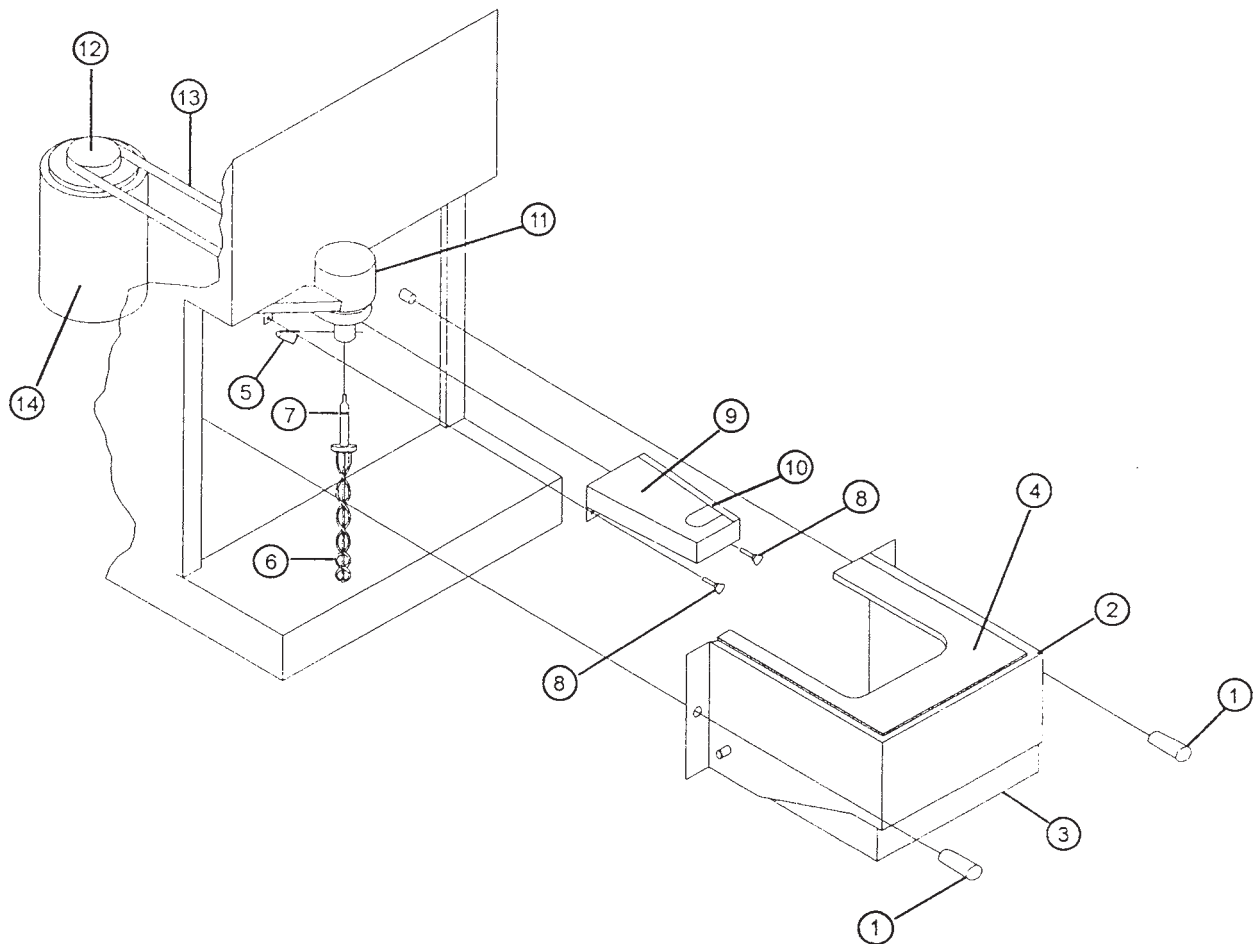

MISCELLANEOUS PARTS

<u>Description</u>	<u>Part No.</u>
Haynes Spray (12 oz.)	508017
Petro-Gel Tube (4 oz.)	508135
Spline Lubricant (2 oz.)	508048
Brush (4" x 8" x 16")	208135
Brush (2.5" x 4" x 12")	208146
Brush (.25" x 4" x 14")	208380
Brush (1" x 3.5" x 18")	208465
Liquid Level Indicator	2119012
Access Door w/o Hole	1134884-01
Access Door w/Hole	2170739
Adaptor-Mix Line (Remote Feed)	1177366
Adaptor O-ring	624607
Adaptor Lock Clip	696130
Hopper Front Cover	314425
Hopper Rear Cover (217-221-222-225-227)	314426
Electrical Box Cover (217-225)	2134890
(Header Decals Purchased By Description)	
Drip Tray	744273
Drip Pan (Rear) w/o Hole	558081
Drip Pan (Rear) w/Hole	558083
Pump Guard	3147873
Drip Tray Grid	417006
Leg Assembly (217,225 Ser.#7027 Plus)	1156592

DECALS

<u>Description</u>	<u>Part No.</u>
Incoming Wires	324015
Water Inlet	324065
Attention Side Panels	324073
Normal Operation Instructions	324083
Rotating Shaft	324103
Danger - Shock Hazard - Disconnect Power	324105
Applicable Electrical Codes	324106
Caution, Hazardous Moving Parts	324107
Turn Off Before Cleaning	324108
Proper Grounding	324113
Elect. Shock Hazard (to power source)	324125
Hazardous Rotating Blades	324141
Clean-Off-Serve	324798
Drive Reset	324164
Freezing	324796
Caution, Hazardous Moving Parts	324346
Cleaning	324509
Adequate Ventilation	324548

NOTE

When ordering safety decals, the \$50.00 minimum **does not** apply.



**DOMESTIC WARRANTY
(Including Mexico)
SOFT SERVE / SHAKE EQUIPMENT**

1. **Scope:**
PW Stoelting, L.L.C. (“Stoelting”) warrants to the first user (the “Buyer”) that the freezing cylinders, hoppers, compressors, drive motors, speed reducers, and augers of Stoelting soft serve / shake equipment will be free from defects in materials and workmanship under normal use and proper maintenance appearing within five (5) years, and that all other components of such equipment manufactured by Stoelting will be free from defects in material and workmanship under normal use and proper maintenance appearing within twelve (12) months after the date that such equipment is originally installed.

2. **Disclaimer of Other Warranties:**

THIS WARRANTY IS EXCLUSIVE; AND STOELTING HEREBY DISCLAIMS ANY IMPLIED WARRANTY OF MERCHANTABILITY OR FITNESS FOR PARTICULAR PURPOSE.

3. **Remedies:**
Stoelting’s sole obligations, and Buyer’s sole remedies, for any breach of this warranty shall be the repair or (at Stoelting’s option) replacement of the affected component at Stoelting’s plant in Kiel, Wisconsin, or (again, at Stoelting’s option) refund of the purchase price of the affected equipment, and, during the first twelve (12) months of the warranty period, deinstallation/reinstallation of the affected component from/into the equipment. Those obligations/remedies are subject to the conditions that Buyer (a) signs and returns to Stoelting, upon installation, the Start-Up and Training Checklist for the affected equipment, (b) gives Stoelting prompt written notice of any claimed breach of warranty within the applicable warranty period, and (c) delivers the affected equipment to Stoelting or its designated service location, in its original packaging/crating, also within that period. Buyer shall bear the cost and risk of shipping to and from Stoelting’s plant or designated service location.

4. **Exclusions and Limitations:**
This warranty does not extend to parts, sometimes called “wear parts”, which are generally expected to deteriorate and to require replacement as equipment is used, including as examples but not intended to be limited to o-rings, auger flights, auger seals, auger support bushings, and drive belts. All such parts are sold

AS IS.

Further, Stoelting shall not be responsible to provide any remedy under this warranty with respect to any component that fails by reason of negligence, abnormal use, misuse or abuse, use with parts or equipment not manufactured or supplied by Stoelting, or damage in transit.

THE REMEDIES SET FORTH IN THIS WARRANTY SHALL BE THE SOLE LIABILITY STOELTING AND THE EXCLUSIVE REMEDY OF BUYER WITH RESPECT TO EQUIPMENT SUPPLIED BY STOELTING; AND IN NO EVENT SHALL STOELTING BE LIABLE FOR ANY INCIDENTAL OR CONSEQUENTIAL DAMAGES, WHETHER FOR BREACH OF WARRANTY OR OTHER CONTRACT BREACH, NEGLIGENCE OR OTHER TORT, OR ON ANY STRICT LIABILITY THEORY.