



Model 4231G & 4231H
OPERATORS MANUAL

Manual No. [513534](#)

Rev.3

This manual provides basic information about the machine. Instructions and suggestions are given covering its operation and care.

The illustrations and specifications are not binding in detail. We reserve the right to make changes to the machine without notice, and without incurring any obligation to modify or provide new parts for machines built prior to date of change.

DO NOT ATTEMPT to operate the machine until instructions and safety precautions in this manual are read completely and are thoroughly understood. If problems develop or questions arise in connection with installation, operation, or servicing of the machine, contact Stoelting.



stoeltingfoodservice.com

Stoelting Foodservice Equipment
502 Highway 67
Kiel, WI 53042-1600
U.S.A.

Main Tel: 800.558.5807
Fax: 920.894.7029

Customer Service: 888.429.5920
Fax: 800.545.0662
Email: foodservice@stoelting.com

© 2014 PW Stoelting, LLC

A Few Words About Safety

Safety Information

Read and understand the entire manual before operating or maintaining Stoelting equipment.

This manual provides the operator with information for the safe operation and maintenance of Stoelting equipment. As with any machine, there are hazards associated with their operation. For this reason safety is emphasized throughout the manual. To highlight specific safety information, the following safety definitions are provided to assist the reader.

The purpose of safety symbols is to attract your attention to possible dangers. The safety symbols, and their explanations, deserve your careful attention and understanding. The safety warnings do not by themselves eliminate any danger. The instructions or warnings they give are not substitutes for proper accident prevention measures.

If you need to replace a part, use genuine Stoelting parts with the correct part number or an equivalent part. We strongly recommend that you do not use replacement parts of inferior quality.



Safety Alert Symbol:

This symbol Indicates danger, warning or caution. Attention is required in order to avoid serious personal injury. The message that follows the symbol contains important information about safety.

Signal Word:

Signal words are distinctive words used throughout this manual that alert the reader to the existence and relative degree of a hazard.



The signal word “WARNING” indicates a potentially hazardous situation, which, if not avoided, may result in death or serious injury and equipment/property damage.



The signal word “CAUTION” indicates a potentially hazardous situation, which, if not avoided, may result in minor or moderate injury and equipment/property damage.

CAUTION

The signal word “CAUTION” not preceded by the safety alert symbol indicates a potentially hazardous situation, which, if not avoided, may result in equipment/property damage.

NOTE (or NOTICE)

The signal word “NOTICE” indicates information or procedures that relate directly or indirectly to the safety of personnel or equipment/property.

TABLE OF CONTENTS

Section	Description	Page
1	INTRODUCTION	1
1.1	Description	1
1.2	Specifications	2
2	OPERATING INSTRUCTIONS	3
2.1	Safety Precautions	3
2.2	Shipment and Transit	4
2.3	Freezer Installation	4
2.4	Electrical Connections	5
3	INITIAL SET-UP AND OPERATION	7
3.1	Operator's Safety Precautions	7
3.2	Operating Controls and Indicators	7
3.3	Sanitizing	9
3.4	Freeze Down and Operation	10
3.5	Mix Information	11
3.6	Removing Mix from Freezer	11
3.7	Cleaning the Freezer	12
3.8	Disassembly of Freezer Parts	12
3.9	Cleaning the Freezer Parts	14
3.10	Sanitize Freezer and Freezer Parts	14
3.11	Assembly of Freezer	14
3.12	Routine Cleaning	16
4	MAINTENANCE INSTRUCTIONS	17
4.1	Preventative Maintenance	17
4.2	Freeze-up	18
4.3	Condenser Service	18
4.4	Extended Storage	18
4.5	Troubleshooting	19
5	REPLACEMENT PARTS	21
5.1	How to Order Parts	21
5.2	Push to Freeze Light/Switch Lamp Replacement	21
5.3	Clean-Off-On Rocker Switch Replacement	21
5.4	Replacement Parts & Reference Drawings	22

LIST OF ILLUSTRATIONS

Figure	Description	Page
1	Model 4231G Freezer	1
2	Specifications	1
3	Warning and Label Locations	3
4	Space and Ventilation Requirements	4
5	Leveling Freezer	5
6	Caster Adjustment	5
7	Connecting Permanent Wiring	5
8	Danger Decal	5
9	Controls	7
10	Mix Inlet Regulator	9
11	Sanitizing Procedure	9
12	Clean Control	9
13	Sanitizing Hopper	9
14	Spigot Opened and Solution Draining	10
15	Pouring the Mix	10
16	Dispensing Product	10
17	Skimming the Foam	11
18	Removing Mix Inlet Regulator	11
19	Draining Mix	12
20	Auger Flight Wear & Front Auger Support Wear	12
21	Removing Front Door	13
22	Removing Spigot	13
23	Removing Auger Supports	13
24	Auger Shafts	13
25	Removing "O" Ring	13
26	Cleaning Freezer Barrel	14
27	Exploded View of Auger	15
28	Exploded View of Front Door	15
29	Installing Mix Inlet Regulators	16
30	Drain Trays	16
31	Skimming Hopper	17
32	Sanitizing Mix Inlet Regulators (Carburetor)	17
33	Push to Freezer Light/Switch Assembly	21
34	Spigot, Front Door and Auger Assembly	22

SECTION 1 INTRODUCTION

1.1 DESCRIPTION

The Stoelting® 4231G freezer is gravity fed. The freezer is equipped with fully automatic controls to provide a uniform product. The freezer is designed to operate with almost any type of commercial soft serve or non-dairy mixes available, including ice milk, ice cream, yogurt, and frozen dietary desserts.

This manual is designed to assist qualified service personnel and operators in the insulation, operation and maintenance of the Stoelting Model 4231 gravity freezer.

Information Packet Location

Model 4231G RIGHT SIDE



Figure 1. Model 4231G Freezer

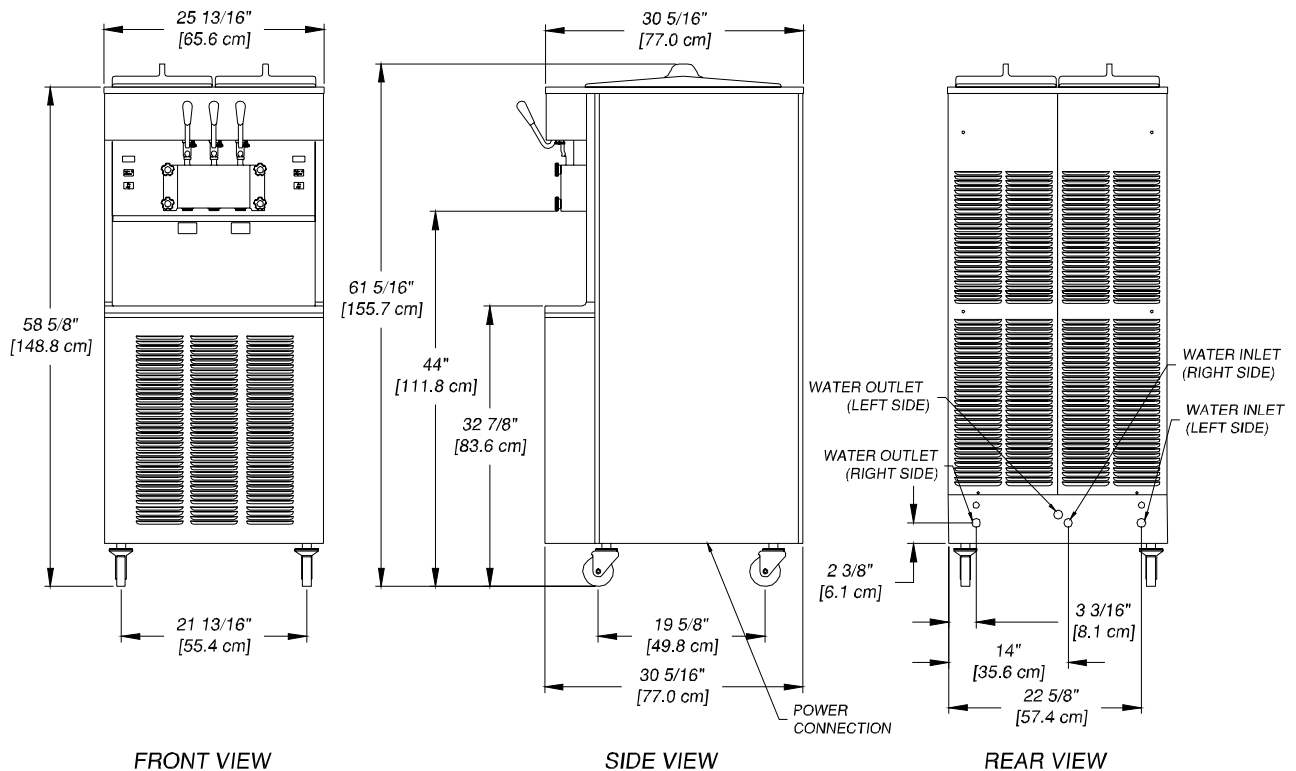

Figure 2. Specifications

1.2 SPECIFICATIONS

MODEL 4231G

FLOOR MODEL

GRAVITY FREEZER

DIMENSIONS

Freezer: 25.90" (65.81 cm) wide x 30.20" (76.7 cm) deep x 60.80" (154.4 cm) high

Crated: 38.00" (96.5 cm) wide x 64.00" (162.5 cm) deep x 70.00" (178.0 cm) high

WEIGHT

Freezer: 640 lbs. (291 kg)

Crated: 815 lbs. (370 kg)

ELECTRICAL

Refer to the nameplate located on the rear of the Freezer.

COOLING

Air-cooled requires 3" (7.6 cm) clearance for all louvered panels. Water-cooled requires 1/2" pipe or 5/8" inside diameter copper water in be installed for adequate water supply.

HOPPER CAPACITY

Two hoppers, 5.6 gallons (21 liters) each, refrigerated and insulated.

SECTION 2 INSTALLATION INSTRUCTIONS

2.1 SAFETY PRECAUTIONS

Do not attempt to operate the freezer until the safety precautions and operating instructions in this manual are read completely and are thoroughly understood.

Take notice of all warning labels on the freezer (Fig. 3). The labels have been put there to help maintain a safe working environment. The labels have been designed to withstand washing and cleaning. All labels must remain legible for the life of the freezer.

Labels should be checked periodically to be sure they can be recognized as warning labels.

If danger, warning or caution labels are needed, indicate the part number, type of label, location of label, and quantity required along with your address and mail to:

STOELTING, LLC
ATTENTION: Customer Service
502 HWY 67
Kiel, Wisconsin 53042-1600

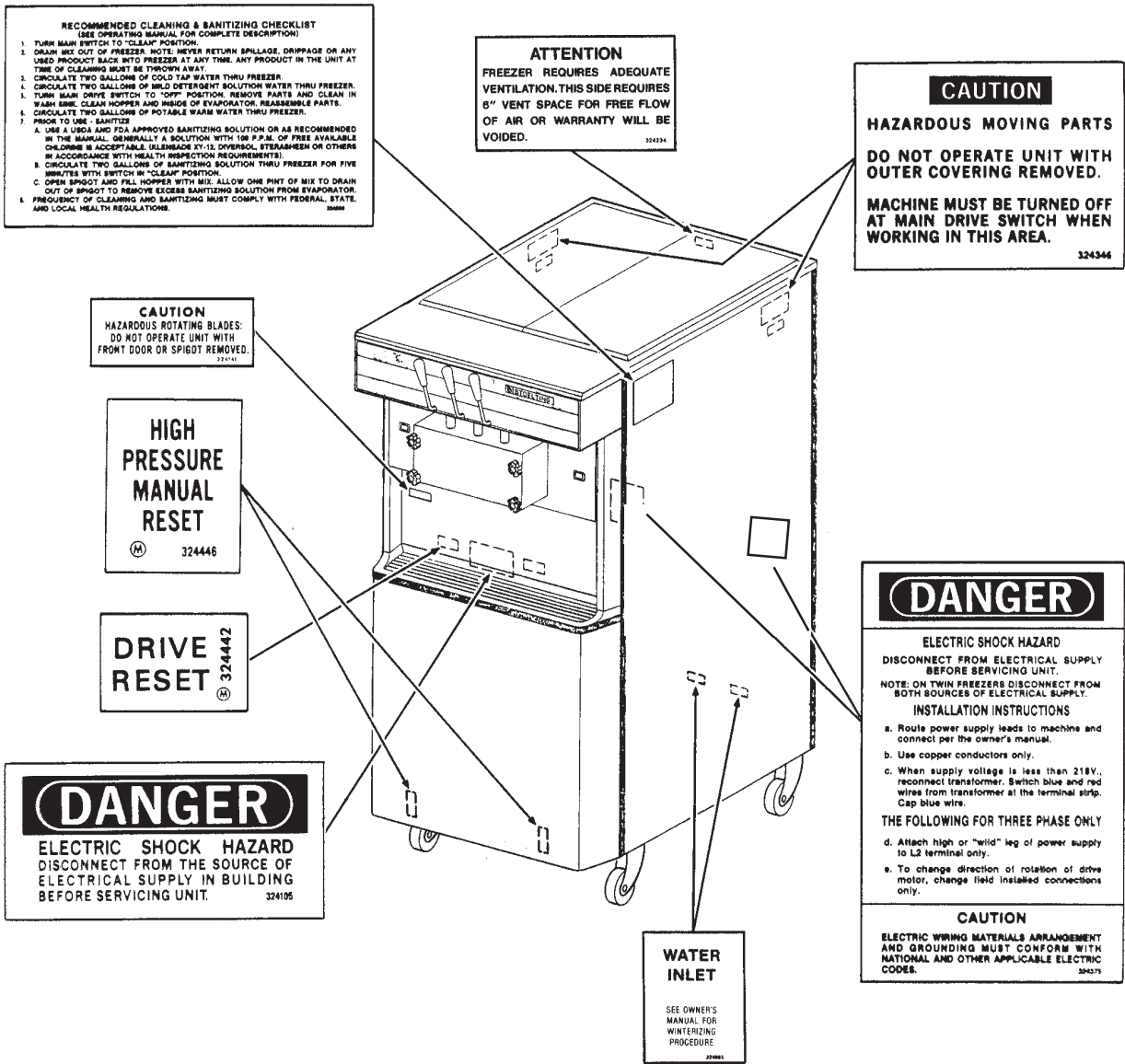

Figure 3. Warning Label Locations

2.2 SHIPMENT AND TRANSIT

The freezer has been assembled, operated and inspected at the factory. Upon arrival at the final destination, the freezer must be checked for any damage that may have occurred during transit.

With the method of packaging used, the freezer should arrive in excellent condition. THE CARRIER IS RESPONSIBLE FOR ALL DAMAGE IN TRANSIT, WHETHER VISIBLE OR CONCEALED. Do not pay the freight bill until the freezer has been checked for damage. Have the carrier note any visible damage on the freight bill. If concealed damage and/or shortage are found later, advise the carrier within 10 days and request inspection. The customer must place claim for damages and/or shortages in shipment with the carrier. **Stoelting, Inc. cannot make any claims against the carrier.**

2.3 FREEZER INSTALLATION



CAUTION

FAILURE TO INSTALL THE FREEZER WITHIN RECOMMENDED LIMITS WILL RESULT IN POOR PERFORMANCE OF THE SYSTEM, PREMATURE COMPONENT FAILURE AND CANCELLATION OF WARRANTY.

Installation of the freezer involves moving the unit close to its permanent location, removing all protective packaging, setting in place and cleaning.



CAUTION

REMOVE LOWER FRONT PANEL BEFORE REMOVING FREEZER FROM SKID.

- A. The freezer requires adequate ventilation. A minimum of 3" (7.6 cm) of vent space is required for free flow of cooling air at the front and back (Fig. 4).

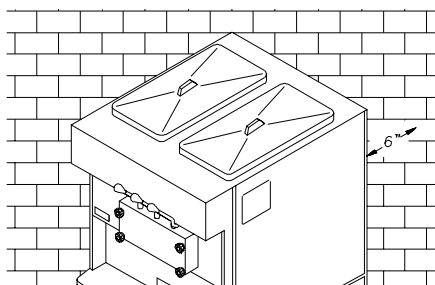

Figure 4. Space and Ventilation Requirements

NOTE

For Air Cooled Unit Only.

A rear block-off panel has been provided to prevent recirculation of hot air beneath the freezer. The rear block-off panel maximizes the efficiency of the freezer. See the illustration for the installation instructions.

1. Remove both back panel mounting screws below the bottom most louver.
2. Attach rear block-off panel to the back panel using the same screws as shown.

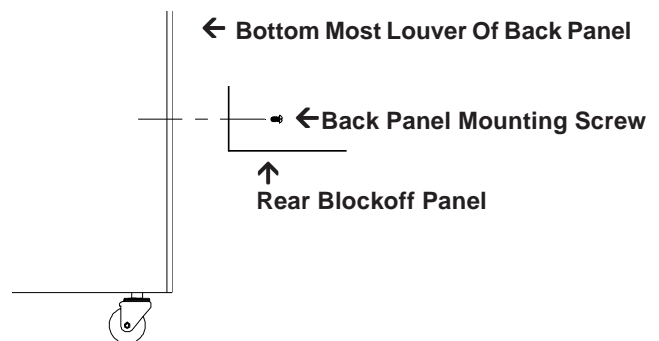

A water-cooled freezer requires an adequate water supply, install 3/8 inch pipe or 1/2 inch inside diameter copper water line to each side of the freezer. Connect water outlet to a drain using a 1/2 inch inside diameter line. Automatic washer hoses work well for final connections. All water connections must comply with local codes.



CAUTION

FLUSH ALL WATER LINES BEFORE INSTALLATION. IN NEW STORES WITH SEDIMENT WATER, ADD SUITABLE FILTER OR STRAINER TO WATER INLET.



CAUTION

FAILURE TO PROVIDE ADEQUATE VENTILATION WILL VOID WARRANTY.

- B. The unit is shipped without casters installed. To install the casters, lift and support the unit while screwing the four casters into the bottom of the frame at each corner.

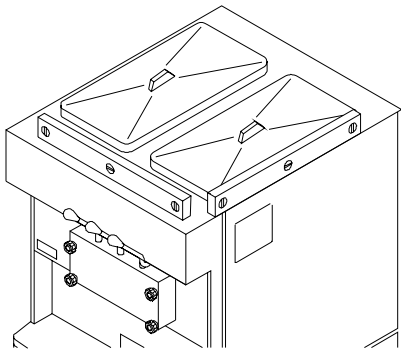

Figure 5. Leveling Freezer

- C. Accurate leveling is necessary for correct drainage of freezer barrel to insure correct over-run and flow. Place a spirit level on top of the freezer at each corner to check for level condition (Fig. 5). If adjustment is necessary, level the freezer by turning the casters in or out (Fig. 6).

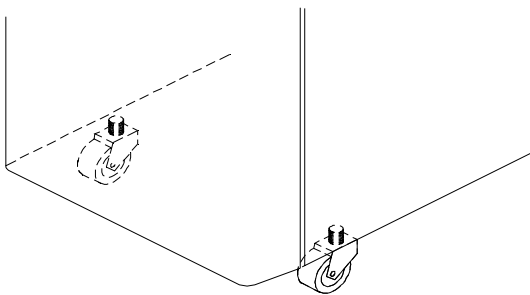

Figure 6. Caster Adjustment

2.4 ELECTRICAL CONNECTIONS



WARNING

BEFORE INSTALLATION OF ANY CABLE IN THE FREEZER, DISCONNECT THE FREEZER FROM ITS ELECTRICAL SUPPLY SOURCE.



CAUTION

ROUTE ELECTRICAL CABLE SO THAT IT CANNOT BE ACCIDENTALLY DAMAGED BY PINCHING, CRUSHING, ETC.

- A. Connect freezer to a properly grounded 208/230 volt (AC), source of electricity.
- B. To access the electrical boxes, remove the two Phillips head screws on the left and right side panels. Then pull the panel down and out.

- C. For location of proper electrical connections, refer to Figure 7.

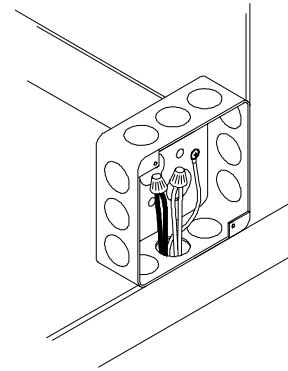

Figure 7. Connecting Permanent Wiring

NOTE

When supply voltage is less than 218V, reconnect transformer. Switch orange and red wires from transformer at the terminal strip and cap blue wire.

- D. Please read decal located on lower electrical box cover (Fig. 8)

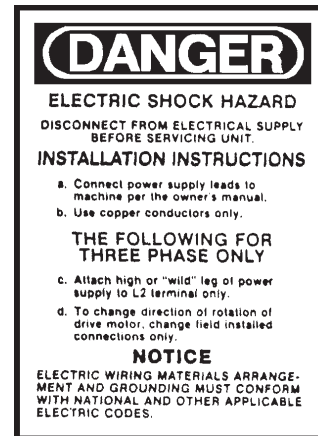

Figure 8. Danger Decal

The model 4231 freezer is two individual freezers in a common enclosure. **EACH SIDE MUST BE CONNECTED INDIVIDUALLY. EACH SIDE MUST HAVE ITS OWN ELECTRICAL SUPPLY.** When making the electrical supply connections, **YOU MUST MAINTAIN STRAIGHT POLARITY FROM SIDE TO SIDE.**

- E. Check the auger shaft rotation by placing the MAIN DRIVE switch in the CLEAN position. Auger shaft rotation is clockwise as viewed through the clear plastic front door. If the rotation is not clockwise, turn the main electrical power OFF. Then reverse L1 and L3 electrical power lines to the junction box (three phase only). Re-check auger shaft rotation.

SECTION 3 INITIAL SET-UP AND OPERATION

3.1 OPERATOR'S SAFETY PRECAUTIONS

SAFE OPERATION IS NO ACCIDENT; Observe these rules:

- A. **Know the freezer.** Read and understand the Operating Instructions.
- B. **Notice all warning labels on the freezer.**
- C. **Wear proper clothing.** Avoid loose fitting garments, and remove watches, rings or jewelry, which could cause a serious accident.
- D. **Maintain a clean work area.** Avoid accidents by cleaning up the area and keeping it clean.
- E. **Stay alert at all times.** Know which switch, push button or control you are about to use and what effect it is going to have.

F. **Disconnect electrical cord for maintenance.** Never attempt to repair or perform maintenance on the freezer until the main electrical power has been disconnected.

G. **Do not operate under unsafe operating conditions.** Never operate the freezer if unusual or excessive noise or vibration occurs.

3.2 OPERATING CONTROLS AND INDICATORS

Before operating the freezer, it is requires the operator know the function of each operating control. Refer to Figure 9 for the location of the operating controls on the freezer.



WARNING

THE OFF-SERVE SWITCH MUST BE PLACED IN THE **OFF** POSITION WHEN DISASSEMBLING FOR CLEANING OR SERVICING. THE FREEZER MUST BE DISCONNECTED FROM ELECTRICAL SUPPLY BEFORE REMOVING ANY ACCESS PANEL.

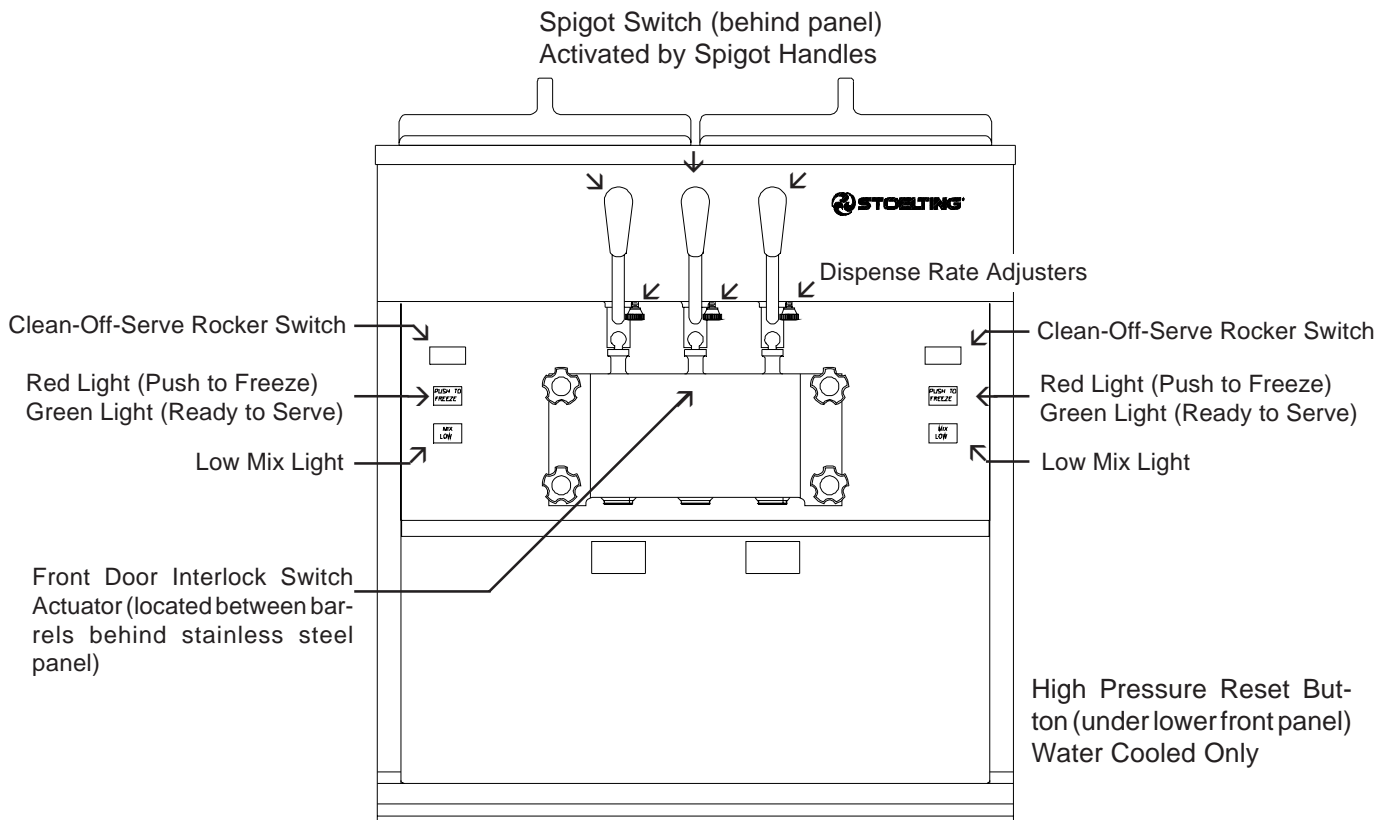

Figure 9. Controls

A. SPIGOT SWITCH

When the spigot handle is opened the SPIGOT switch will start the auger drive motor and refrigeration systems. When the spigot handle is closed, the auger drive motor and compressor will remain on until the product in the barrel reaches the proper consistency.

B. CLEAN-OFF-SERVE SWITCH

The CLEAN-OFF-SERVE switch is a three-position rocker switch used to control the operation of the refrigeration system and auger. When the switch is placed in the CLEAN position, the refrigeration system will be off and the auger **will** rotate for cleaning.

When the switch is placed in the OFF position, the refrigeration system and auger **will not** operate.

When the switch is placed in the SERVE position, the refrigeration system and auger **will** operate automatically. The switch should be placed in the ON position for normal operation.

C. PUSH TO FREEZE SWITCH

The illuminating PUSH TO FREEZE switch is used to start the freezing cycle. During the initial freeze down, the CLEAN-OFF-SERVE rocker switch is placed in the SERVE position. Then the PUSH TO FREEZE switch is pressed until the drive motor and compressor comes "ON."

NOTE

After the gearmotor starts, there is a 3-second delay before the compressor starts.

During the normal operation, the red PUSH TO FREEZE switch will illuminate after the freezer has been in idle for the pre-set time. Before drawing product, press the red PUSH TO FREEZE switch if it is illuminated. Wait until the green lens is illuminated before dispensing.

NOTE

If the freezer shuts off and the PUSH TO FREEZE light flashes, you have an error condition. Turn the CLEAN-OFF-SERVE switch to the OFF position, correct the problem and turn the freezer back on.

GREEN LIGHT

The green lens is used to indicate that the product has reached the proper consistency and is ready to be dispensed.

NOTE

If the PUSH TO FREEZE lens is illuminated, push the PUSH TO FREEZE switch and wait until the green lens illuminates before dispensing.

MIX LOW LIGHT

The MIX LOW light is used to indicate when the hopper is low on mix. When the light is illuminated fill the hopper with mix.



CAUTION

FAILURE TO REFILL HOPPER IMMEDIATELY MAY RESULT IN OPERATIONAL PROBLEMS.

D. DISPENSE RATE ADJUSTER

The dispense rate adjuster limits the opening of the spigot.

To adjust product dispense rate, turn the adjusting knob clockwise for slower flow and counterclockwise for faster flow.

E. DOOR INTERLOCK SWITCH

When the door is securely fastened the freezer will operate normally. When the door is removed, the drive and compressor will not run.

3.3 SANITIZING

Sanitizing must be done after the freezer is clean and just before the hopper is filled with mix. **Sanitizing the night before is not effective.** However, you should always clean the freezer and parts after using it.



WARNING

THE UNITED STATES DEPARTMENT OF AGRICULTURE AND THE FOOD AND DRUG ADMINISTRATION REQUIRE THAT ALL CLEANING AND SANITIZING SOLUTIONS USED WITH FOOD PROCESSING EQUIPMENT BE CERTIFIED FOR THIS USE.

When sanitizing the freezer, refer to local sanitary regulations for applicable codes and recommended sanitizing products and procedures. The frequency of sanitizing must comply with local health regulations. Mix sanitizer according to manufacturer's instructions to provide a 100 parts per million strength solution. Mix sanitizer in quantities of no less than 2 gallons (7.5 liters) of 120°F water. Allow sanitizer to contact the surfaces to be sanitized for 5 minutes. Any sanitizer must be used only in accordance with the manufacturer's instructions.



CAUTION

PROLONGED CONTACT OF SANITIZER WITH FREEZER MAY CAUSE CORROSION OF STAINLESS STEEL PARTS.

In general, sanitizing may be conducted as follows:

- A. Push the mix inlet regulator fully into the hopper (Fig. 10).

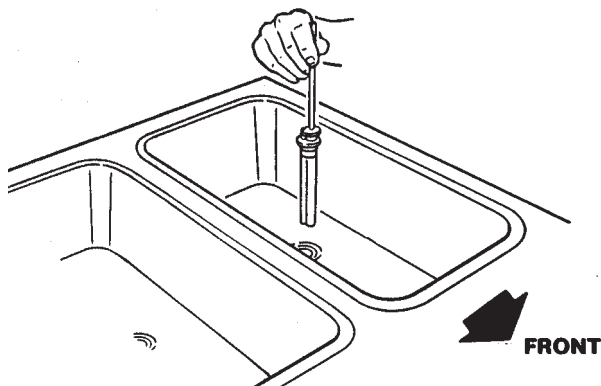

Figure 10. Mix Inlet Regulator

- B. Prepare 2 gallons (7.5 liters) of sanitizing solution following manufacturer's instructions. Pour into hopper with mix inlet regulator in place (Fig. 11).

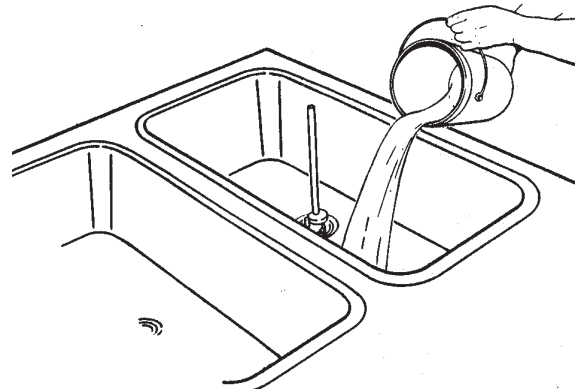

Figure 11. Sanitizing Procedure

- C. Place the CLEAN-OFF-SERVE rocker switch in the CLEAN position. Check for leaks around the front door seal (Fig. 12).

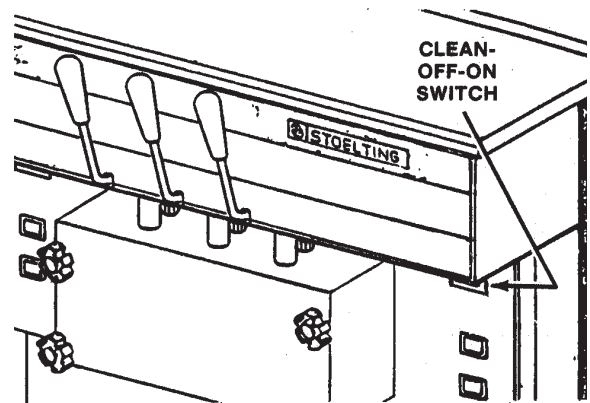

Figure 12. Clean Control

- D. Clean sides of hopper, mix inlet regulator and underside of hopper cover using a sanitized soft bristle brush dipped in the sanitizing solution (Fig. 13).

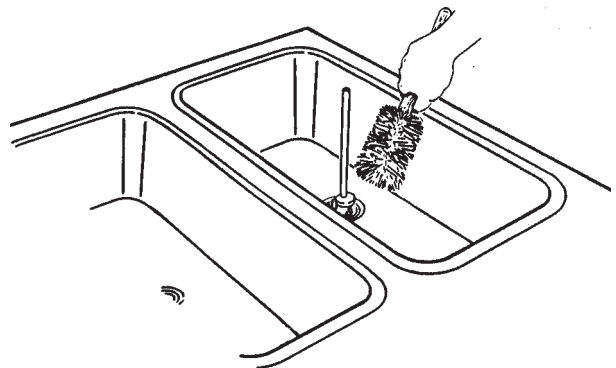

Figure 13. Sanitizing Hopper

- E. After five minutes, place the bucket under the spigots and open all three spigots to drain the sanitizing solution. When the solution has drained, place the CLEAN-OFF-SERVE switch in the OFF position. Allow the freezer barrel to drain completely (Fig. 14).

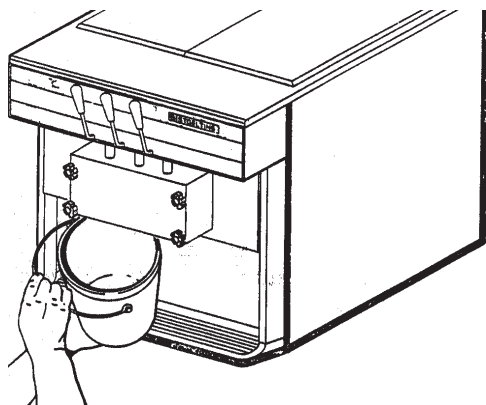

Figure 14. Spigot Opened and Solution Draining

3.4 FREEZE DOWN AND OPERATION

This section covers the recommended operating procedures to be followed for the safe operation of the freezer.

- A. Sanitize just prior to use.
- B. Place the CLEAN-OFF-SERVE switch in the OFF position.
- C. With spigots open, pour approximately 1 gallon (3.8 liters) of mix into the hopper. Allow the mix to flush out about 8 ounces (0.23 liters) of sanitizing solution and liquid mix. Close the spigot. (Fig.15)

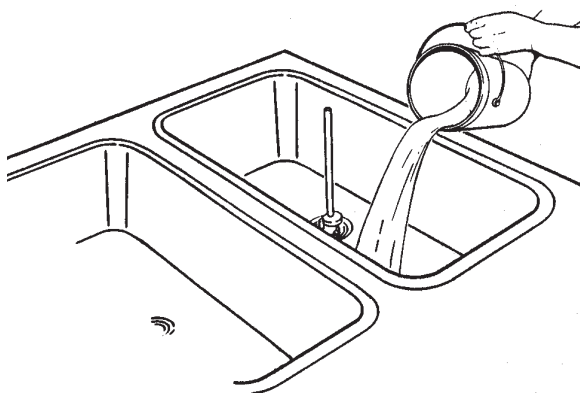

Figure 15. Pouring the Mix

- D. Fill hoppers with approximately 6-1/2 gallons (11.4 liters) of pre-chilled (40°F or 4°C) mix.

⚠ CAUTION

DO NOT OVERFILL THE HOPPER. MIX LEVEL MUST NOT BE HIGHER THAN 2" (5CM) FROM THE TOP OF THE AIR INLET TUBE ON THE MIX INLET REGULATOR.

- E. The freezer barrel will automatically fill until it is about 1/2 full (about 3 min.) If the freezer barrel does not fill, check for obstruction in the mix inlet regulator "O" Ring, check for leaks at the mix inlet regulator was installed correctly, or that the freezer is level.
- F. Place the CLEAN-OFF-SERVE rocker switch in the SERVE position, then press PUSH TO FREEZE switch until the drive motor and compressor come ON.

NOTE

After the gearmotor starts, there is a 3-second delay before the compressor starts.

- G. After about 6 to 10 minutes the freeze will shut OFF and the green lens will illuminate. The product is ready to serve. Freeze down time may be longer for some frozen diet dessert mixes.
- H. For normal dispensing, move the spigot handle open 60° (Fig. 16).

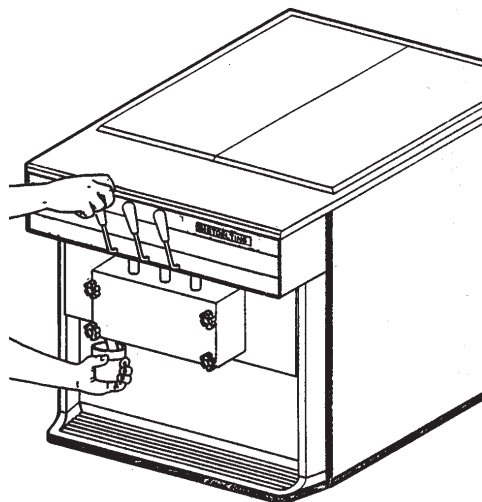

Figure 16. Dispensing Product

⚠ CAUTION

REFRIGERATION IS AUTOMATICALLY ACTIVATED WHEN THE SPIGOT IS OPENED. CLOSE THE SPIGOT COMPLETELY AFTER DISPENSING.

- I. The freezer is designed to dispense the product at a reasonable draw rate. If the freezer is overdrawn, the result is a soft product or a product that will not dispense at all. If this should occur, allow the freezer to run for approximately 30 seconds before dispensing additional product. After a while the operator will sense or feel the freezer is beginning to fall behind, and will slow down the rate of draw so as not to exceed the capacity.
- J. **Do not** operate the freezer when the level indicator shows the hopper is empty.

NOTE

The freezer has a standby mode sometimes referred to as a sleep or energy conservation mode. When the freezer is not used, after a preset time, it will remain there until someone draws a product or pushes the PUSH TO FREEZE switch. In the standby mode, the freezer will keep the product below 45°F. Standby modes are not to be used in place of cleaning and sanitizing. Federal, State, and Local regulatory agencies determine frequency of cleaning and sanitizing.

3.5 MIX INFORMATION

Mix can vary considerably from one manufacturer to another. Differences in the amount of butterfat content and quantity and quality of other ingredients have a direct bearing on the finished frozen product. A change in freezer performance that cannot be explained by a technical problem may be related to the mix. When changing from one type of mix to another such as yogurt to Vitari, you may have to change the mix inlet regulator and/or control settings. Please call your distributor for further information.

Proper product serving temperature varies from one manufacturer's mix to another. Mixes should provide a satisfactory product in the 18° to 20°F (-7° to -6°C) range.

When checking the temperature, stir the thermometer in the frozen product to read the true temperature.

Mix **does not** improve with age. Old mix, or mix that has been stored at too high a temperature, can result in a finished product that is less than satisfactory from the appearance and taste standpoint. To retard bacteria growth in dairy based mixes; the best storage temperature range is between 36° to 40°F (2.2° to 4.4°C).

Some products tend to foam more than others do. If excess foam should occur, skim off with a sanitized utensil and discard (Fig. 17). Periodically, stir the mix in the hopper with a sanitized utensil.

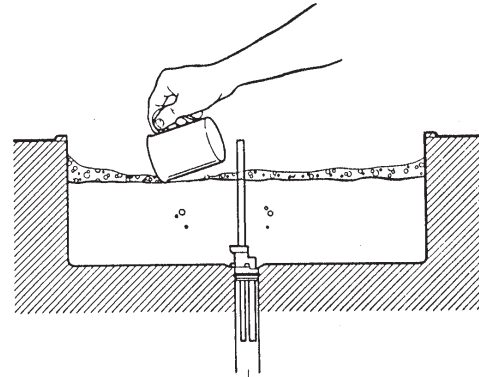

Figure 17. Skimming the Foam

3.6 REMOVING MIX FROM FREEZER

To remove the mix from the freezer, refer to the following steps:

- A. Remove the mix inlet regulator from the hopper by pulling straight up (Fig. 18).

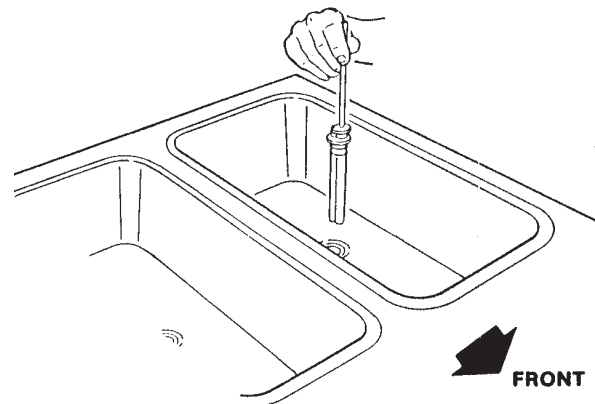

Figure 18. Removing Mix Inlet Regulator

- B. Place the CLEAN-OFF-SERVE rocker switch in the CLEAN position. Allow the mix to agitate in freezer barrel until the mix has become a liquid.
- C. Drain the liquid mix by opening the spigot. A bucket or container should be placed under the spigot to catch the liquid mix (Fig. 19).

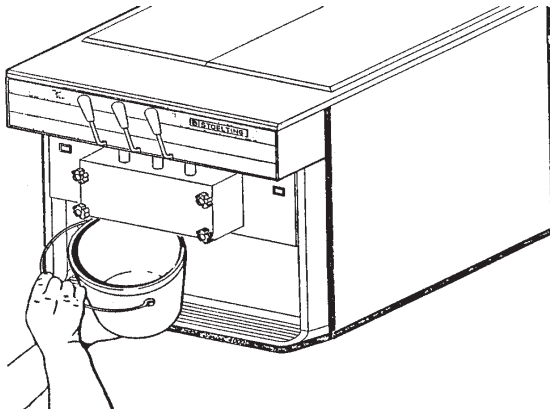

Figure 19. Draining Mix

- D. Place the CLEAN-OFF-SERVE switch in the OFF position.

3.7 CLEANING THE FREEZER

NOTE

The frequency of cleaning the freezer and freezer parts must comply with local health regulations.

After the mix has been removed from the freezer, the freezer must be cleaned. To clean the freezer, refer to the following steps:

- A. Close the spigot and fill the hoppers with 2 gallons (7.5 liters) of cold tap water.
- B. Place the CLEAN-OFF-SERVE switches in the CLEAN position.
- C. Allow the water to agitate for approximately five minutes.
- D. Open the spigots to drain the water. Remember to place a bucket or container under the spigots to catch the water. When the water has drained, turn the CLEAN-OFF-SERVE switches to the OFF position. Allow the freezer barrel to drain completely.

- E. Repeat steps A through D using a mild detergent solution.

3.8 DISASSEMBLY OF FREEZER PARTS

⚠ CAUTION

PLACE THE CLEAN-OFF-SERVE ROCKER SWITCHES IN THE OFF POSITION BEFORE DISASSEMBLING FOR CLEANING OR SERVICING.

Inspection for worn or broken parts should be made at every disassembly of the freezer for cleaning or other purposes. All worn or broken parts should be replaced to ensure safety to both the operator and the customer and to maintain good freezer performance and a quality product. Two normal wear areas are the auger flights and front auger support bearing (Fig. 20). Frequency of cleaning must comply with the local health regulation.

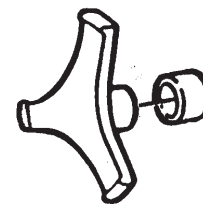
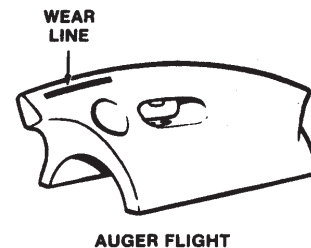

Figure 20. Auger Flight Wear and Front Auger Support Wear

To disassemble the freezer, refer to the following steps:

- A. Remove the mix inlet regulators from the hoppers by pulling straight up.
- B. Remove the front door by turning off the circular knobs and then pulling the front door off the studs (Fig. 21).

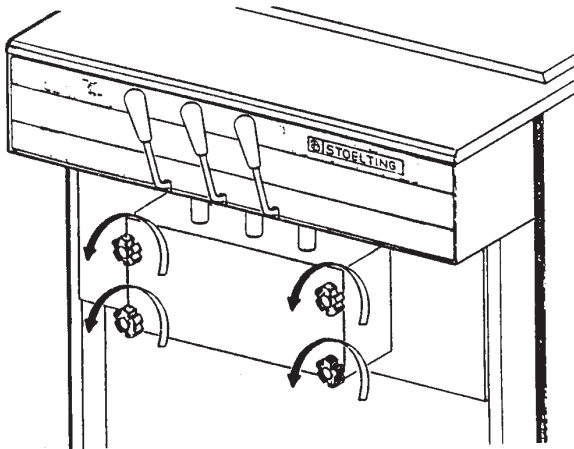

Figure 21. Removing Front Door

- C. Remove rosette cap. Push the spigot body through the bottom of the front door and remove the spigot body (Fig. 22).

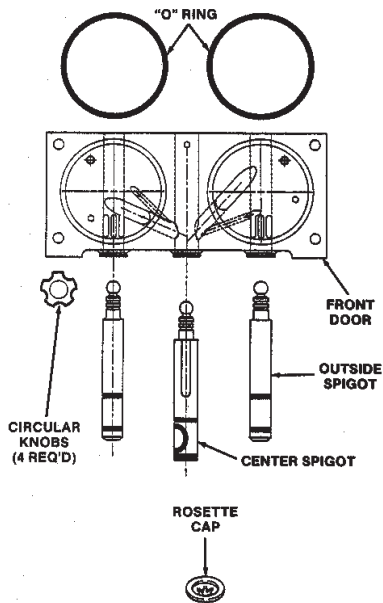

Figure 22. Removing Spigot

- D. Remove the front auger supports and bearings (Fig. 23).

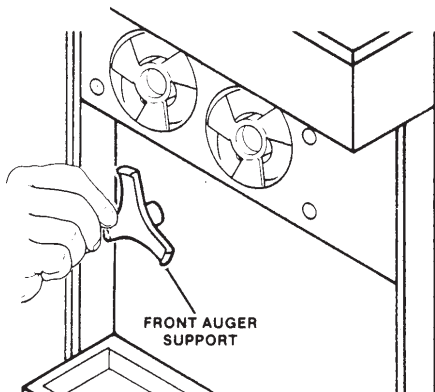

Figure 23. Removing Auger Supports

- E. Remove the auger assemblies from the freezer. Pull the augers out of the freezer barrel slowly. As the augers are being pulled out, carefully remove each of the plastic flights with springs (Fig. 24).

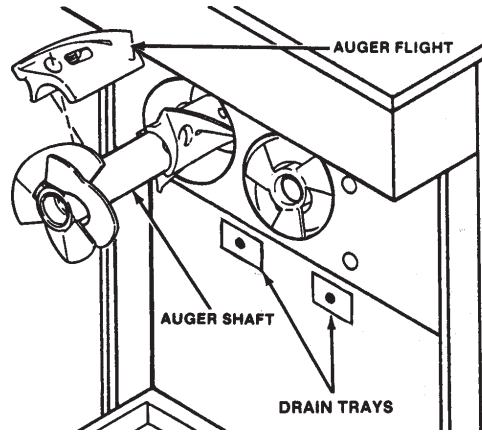

Figure 24. Auger Shafts

- F. Keep the rear of the auger shafts tipped up once they are clear of the freezer barrels to avoid dropping rear seals.

- G. Remove the rear seals.

- H. Wipe socket lubricant from the drive end (rear) of the auger with a cloth or paper towel.

- I. Remove all "O" Rings from parts by first wiping off the lubricant using a clean paper towel. Then squeeze the "O" Ring upward with a dry cloth. When a loop is formed, roll out of the "O" Ring groove (Fig. 25).

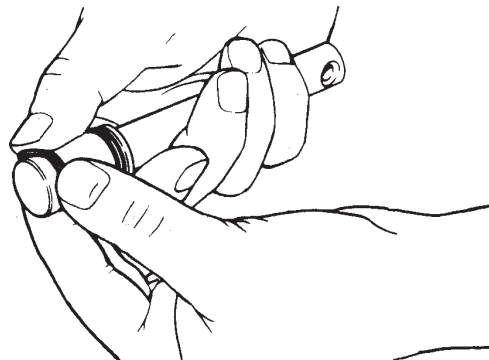

Figure 25. Removing O-Ring

! WARNING

DO NOT USE ANY TYPE OF SHARP OBJECT TO REMOVE THE "O" RINGS.

- J. Remove drain trays.

3.9 CLEANING THE FREEZER PARTS

Place all loose parts in a pan or container and take to the wash sink for cleaning. To clean freezer parts refer to the following steps:

- A. Place all parts in warm mild detergent water and clean with brushes provided. Rinse all parts with clean hot water.



CAUTION
DO NOT DAMAGE PARTS BY DROPPING OR ROUGH HANDLING.

- B. Wash the hopper and freezer barrel with warm detergent water and brush provided (Fig. 26).

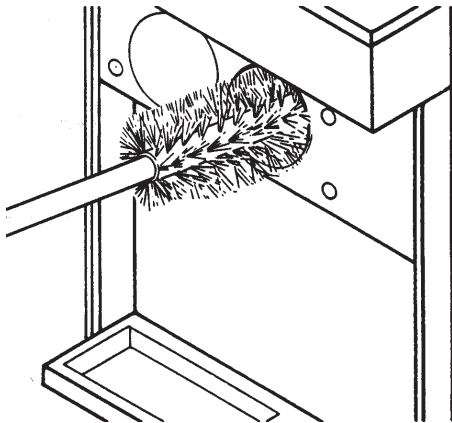

Figure 26. Cleaning Freezer Barrel

- C. Clean the drip tray and insert with a soap solution. Rinse with clean hot water.

3.10 SANITIZE FREEZER AND FREEZER PARTS

- A. Use a sanitizer mixed according to manufacturer's instructions to provide a 100 parts per million strength solution. Mix sanitizer in quantities of no less than two gallons (7.5 liters) of 120°F water. Allow the sanitizer to contact the surface for 5 minutes. Any sanitizer must be used only in accordance with the manufacturer's instructions.

- B. Place all parts in the sanitizing solution, then remove and let air dry.

- C. Using this sanitizing solution and the large barrel brush provided, sanitize the rear of the barrel and drive area by dipping the brush in the sanitizing solution and brushing the rear of the barrel.

3.11 ASSEMBLY OF FREEZER

To assemble the freezer parts, refer to the following steps:

NOTE

Petro-Gel sanitary lubricant or equivalent must be used when lubrication of parts is specified.

NOTE

The United States Department of Agriculture and the Food and Drug Administration require that lubricants used on food processing equipment be certified for this use. Use lubricants only in accordance with the manufacturer's instructions.

- A. Assemble all "O" Rings onto parts dry, **without lubrication**. Then apply a thin film of sanitary lubrication to exposed surfaces of the "O" Rings. Apply thin film of sanitary lubricant to metal part of rear seal. Also apply a thin film of sanitary lubricant inside the hole on the front of the auger.
- B. Assemble the rear seals onto the augers with the large end to the rear. Be sure the "O" Ring is in place before installing the rear seal.
- C. Lubricate the inside of the auger drive sockets (rear) with a small amount of white socket lubricant. A small container of socket lubricant is shipped with the freezer.
- D. Screw the springs onto the studs in plastic flights. **Springs must be screwed into the flights completely** to provide proper tension (Fig. 27).

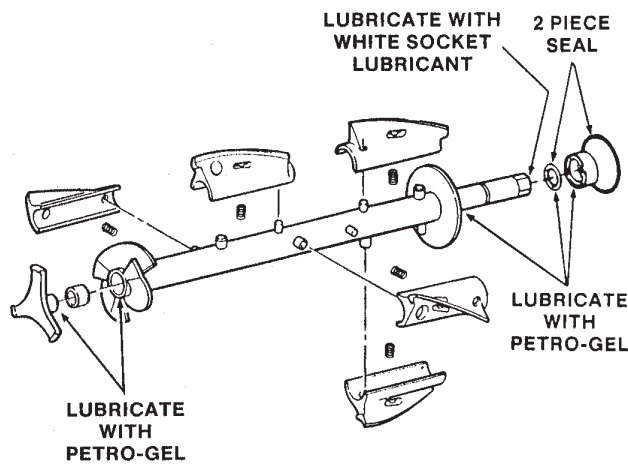

Figure 27. Exploded View of Auger

CAUTION

DO NOT PLACE THE MIX INLET REGULATOR INTO THE HOPPER BEFORE INSTALLING THE AUGER.

- E. Install the two plastic flights onto rear of the auger and insert part way into freezer barrel.
- F. Install the remaining plastic flights, push the auger into the freezer barrel and rotate slowly until the auger engages the drive shaft.
- G. Install the auger support and bearing into the front of the augers with one leg of the support at 9 o'clock.

NOTE

Apply a small amount of Petro-Gel to the surface of the cam on the spigot handle prior to assembly of handle to the spigot body.

- H. Install the spigot bodies with "O" Rings into the front door from the bottom (Fig. 28). Push straight up until the spigots are in place. Install rosette cap.
- I. Install the front door on the freezer.
- J. Install the circular knobs on the freezer studs.

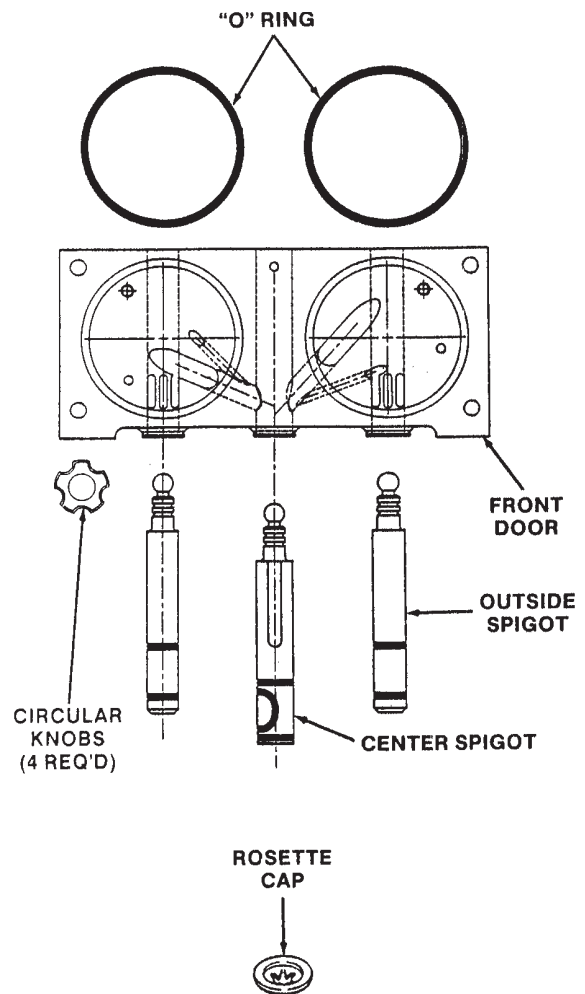

Figure 28. Exploded View of Front Door

CAUTION

FINGER TIGHTEN THE CIRCULAR KNOBS EVENLY. DO NOT OVERTIGHTEN KNOBS.

- Look for the proper seal between the freezer barrel, "O" Ring, and front doors.
- K. Install the mix inlet regulators into the hopper with the air inlet (long) tube toward the front of the freezer (Fig. 29).

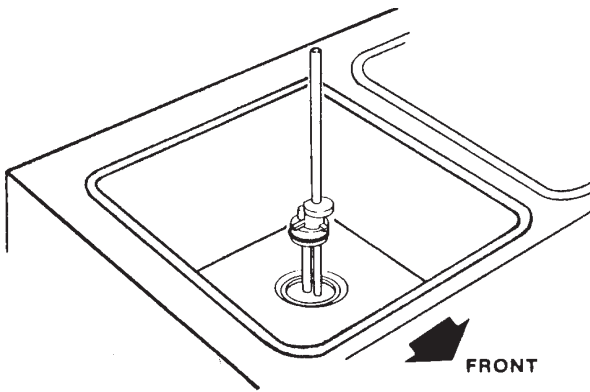

Figure 29. Installing Mix Inlet Regulators

NOTE

Refer to Section 3.3 for sanitizing the assembled freezer before filling with mix.

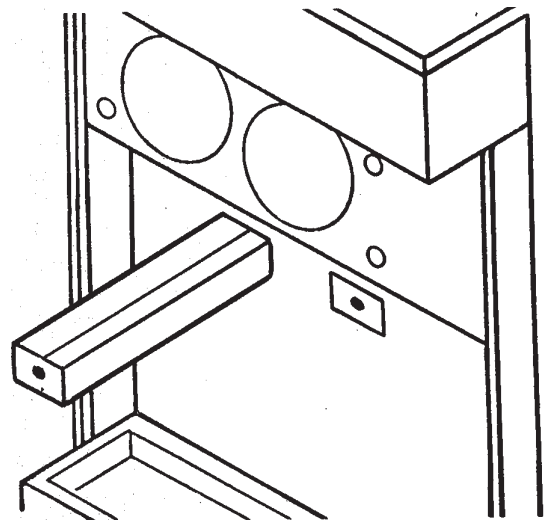

Figure 30. Drain Trays

- L. Install the drain trays (Fig. 30).

CAUTION

DRAIN TRAYS MUST BE IN PLACE BEFORE OPERATING FREEZER TO PREVENT DAMAGE FROM POSSIBLE AUGER SEAL LEAKS.

3.12 ROUTINE CLEANING

To remove spilled or dried mix for the freezer exterior, simply wash in the direction of the finish with warm soapy water and wipe dry. **Do not** use highly abrasive materials, as they will mar the finish.

SECTION 4 MAINTENANCE INSTRUCTIONS

4.1 PREVENTIVE MAINTENANCE

It is recommended that a preventive maintenance schedule be followed to keep the freezer clean and operating properly. The following steps are suggested as a preventive maintenance guide.



WARNING
NEVER ATTEMPT TO REPAIR OR PERFORM MAINTENANCE ON FREEZER UNTIL THE MAIN ELECTRICAL POWER HAS BEEN DISCONNECTED.

The United States Department of Agriculture and the Food and Drug Administration require that lubricants used on food processing equipment be certified for this use. Use lubricants only in accordance with the manufacturer's instructions.

A. DAILY

1. The exterior should be kept clean at all times to preserve the luster of the stainless steel. A mild alkaline cleanser is recommended. Use a soft cloth or sponge to apply the cleanser.
2. Using a sanitized one-pint aluminum overrun container, skim the mix in the hopper to remove any foam buildup (Fig. 31).

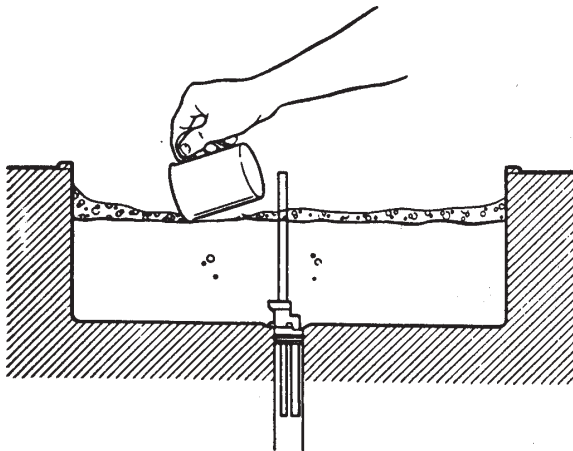

Figure 31. Skimming Hopper

3. Run a sanitized brush down mix inlet regulator (carburetor) tubes (Fig. 32).

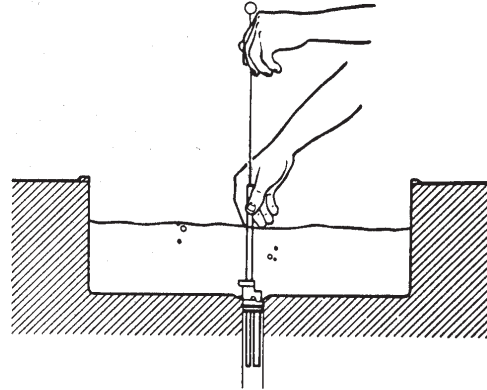

Figure 32. Sanitizing Mix Inlet Regulator (Carburetor)

NOTE

When sanitizing, the skimmer, brush and the hand that holds the mix inlet regulator (carburetor) must also be sanitized.

4. Note any unusual noises or operating conditions upon startup. Repair or rectify immediately if problems exist.

NOTE

Do not use acid cleaners, strong caustic compounds or abrasive materials to clean any part of the freezer exterior or plastic parts.



CAUTION
INSPECTION FOR WORN OR BROKEN PARTS SHOULD BE MADE AT EACH DISASSEMBLY OF THE FREEZER.

B. WEEKLY

1. Check all "O" Rings for excessive wear and replace if necessary.
2. Check scraper blades, front bearing and rear bearing for wear damage (paragraph 3.8).

C. MONTHLY

1. Check drive belt for wear.
2. Check condenser for dirt.

4.2 FREEZE-UP

If a freeze-up does occur, use the following steps to thaw the mix in the freezer barrel:



IF THE DRIVE BELT SQUEALS WHEN THE CLEAN-OFF-SERVE SWITCH IS PLACED IN THE SERVE POSITION, OR WHEN THE SPIGOT IS OPENED TO DISPENSE PRODUCT, TURN THE CLEAN-OFF-SERVE SWITCH TO THE OFF POSITION.

- A. Check to make sure the spigot handle is closed completely, spigot switch is functioning properly, there is mix in the hopper, or the mix inlet regulator (carburetor) is not plugged.
- B. If drive motor overload was tripped, remove the middle front panel and push the reset button. If it will not reset wait 5 minutes and try again.
- C. Place the CLEAN-OFF-SERVE switch in the SERVE position and push the PUSH TO FREEZE switch.
- D. The product will be ready to serve when the green light illuminates.
- E. If the freezer continues to freeze-up, contact a qualified refrigeration service technician, local distributor, or Stoelting, Inc.

4.3 CONDENSER SERVICE

- A. Visually inspect the condenser for dirt by shining a light through the louvers.
- B. If the condenser is dirty, vacuum all loose dirt.
- C. If using compressed air or CO-2 tank to blow out the dirt, first place a wet towel over the front of the condenser.

- D. Blow out the dirt from the back of the condenser. Most of the dirt will cling to the wet towel.



THIS PROCEDURE EMITS A LOUD NOISE.

- E. An alternative method is to clean with a condenser brush and vacuum.

4.4 EXTENDED STORAGE

Refer to the following steps for winterizing the freezer for winter lay-up or any extended period of storage.

- A. Clean thoroughly with a **warm** mild detergent all parts that come in contact with mix. Rinse in clear water and dry all parts. **Do not** sanitize as prolonged exposure of metal parts to some sanitizers can cause corrosion.

NOTE

Do not let cleaning solution stand in freezer barrel or hopper during the shutdown period.

- B. Remove, disassemble, and clean the front door, auger and mix inlet regulator (carburetor). Leave disassembled during the shutdown period.
- C. Place plastic auger flights, rear bearing and front bearing in a plastic bag with a moist paper towel. This will prevent parts from becoming brittle if exposed to dry air over an extended period of time (over 30 days).



BARREL MUST BE EMPTY FOR FOLLOWING PROCEDURE.

- D. On water cooled freezers, shut off and disconnect water supply at rear of freezer; run compressor for 2 to 3 minutes to open water valve, and blow out all water first through inlet, then outlet line, using air or carbon dioxide.
- E. Disconnect the freezer from the electrical supply in the building.

4.5 TROUBLESHOOTING



NEVER ATTEMPT TO REPAIR OR PERFORM MAINTENANCE ON FREEZER UNTIL THE MAIN ELECTRICAL POWER HAS BEEN DISCONNECTED.

<u>Problem</u>	<u>Possible Cause</u>	<u>Remedy</u>
Freezer does not run	<ol style="list-style-type: none">1. Power to freezer is off.2. Fuse or circuit breaker is blown or tripped.3. Freeze-up4. High-pressure cutout tripped5. Drive motor OFF ON Timer.	<ol style="list-style-type: none">1. Supply power to freezer2. Replace or reset. (If condition continues See note 1 or 2)3. See paragraph 4.3.4. Correct problem and reset.5. Place the CLEAN-OFF-SERVE switch to the OFF position the reset.
Freezer shuts off on error	<ol style="list-style-type: none">1. Low or no mix in hopper.2. Low or no overrun.3. Refrigeration problem.	<ol style="list-style-type: none">1. Add mix.2. Check mix inlet regulator.3. Check system. (See note 1.)
Product is too soft	<ol style="list-style-type: none">1. No vent space for free flow of cooling air.2. Air temperature entering condenser is above 100°F. (Air cooled.)3. Condenser is dirty. (Air-cooled)4. Consistency setting too soft5. Stabilizers in mix are broken down.6. Refrigeration problem.	<ol style="list-style-type: none">1. A minimum of 6 inches of vent space required. (See paragraph 2.2).2. Change location or direct hot air away from freezer.3. Clean (See paragraph 4.6).4. Readjust (See paragraph 4.2).5. Remove mix, clean, sanitize and freeze down with fresh mix.6. Check system. (See note 1.)
Product is too firm.	<ol style="list-style-type: none">1. Consistency setting too firm2. Spigot not fully closed.	<ol style="list-style-type: none">1. Readjust. (See paragraph 4.2.)2. Fully close spigot.
Product does not Dispense.	<ol style="list-style-type: none">1. No mix in hopper2. Mix inlet regulator (carburetor) mix inlet tube is plugged.3. Special mix inlet regulator (carburetor) needed for mix being used.4. Capacity of freezer is being exceeded.5. Drive motor overloaded.6. Drive belt failure.7. Freeze-up	<ol style="list-style-type: none">1. Fill hopper with mix.2. Unplug, using a small sanitized brush.3. Order special mix inlet regulator (carburetor). (See note 2.)4. Slow up on the draw rate.5. Place reset lever in the ON position. (If condition continues see note 1 or 2.)6. See paragraph 4.4.7. See paragraph 4.3.
Drive belt slipping	<ol style="list-style-type: none">1. Worn drive belt.2. Freeze-up	<ol style="list-style-type: none">1. Replace drive belt. (See paragraph 4.4.)2. See paragraph 4.3.

Low overrun	<ol style="list-style-type: none"> 1. Mix inlet regulator (carburetor) missing. 2. Mix inlet regulator (carburetor) "O" Ring missing. 3. Mix inlet regulator (carburetor) air tube blocked. 	<ol style="list-style-type: none"> 1. Replace mix inlet regulator (carburetor). 2. Replace mix inlet regulator (carburetor) "O" Ring. 3. Clean with sanitizer brush.
Front door leaks.	<ol style="list-style-type: none"> 1. Front door knobs are loose. 2. Spigot parts are not lubricated. 3. Chipped or worn spigot "O" Rings. 4. "O" Rings or spigot installed wrong. 5. Spigot hole in front door nicked or scratched. 	<ol style="list-style-type: none"> 1. Tighten knobs. 2. See paragraph 3.11. 3. Replace "O" Rings. 4. Remove spigot and check "O" Rings. 5. Replace front door.
Hopper will not Maintain mix temperature below 45°F (7°C).	<ol style="list-style-type: none"> 1. EPR valve needs to be adjusted. 2. Temperature control failure. 3. Refrigeration problem. 	<ol style="list-style-type: none"> 1. (See note 1.) 2. Replace. (See notes 1 or 2.) 3. Check system. (See note 1.)

1. Must be performed by a qualified service person.
2. The local dealer, distributor or Stoelting, LLC, Service Department should be contacted. Write or call:

Stoelting, LLC
502 Hwy. 67,
Kiel, WI 53042

Phone (920) 894-2293.

SECTION 5 REPLACEMENT PARTS

5.1 HOW TO ORDER PARTS

To assure receipt of the proper replacement parts, supply your dealer or distributor with the following information:

- A. Model number of equipment.
- B. Serial number of model, stamped on nameplate.

<u>Part Number</u>	<u>Description</u>
324014	Decal Black Arrow
324141	Decal Caution Rotating Blades
324509	Decal Cleaning
324548	Decal Ventilation
324346	Decal Caution
324393	Decal – Drip Tray
324803	Decal – Header Panel (Stoelting Logo)
324804	Decal - Header Panel (Stoelting Swirl)
324806	Decal - Header Panel (A & W Logo)
324798	Decal – CLEAN/OFF/SERVE
324125	Decal – Elec. Shock Hazard

- C. Part number, part name and quantity needed. Common part names and numbers are listed in this manual.

5.2 PUSH TO FREEZE LIGHT/SWITCH LAMP REPLACEMENT

To change a lamp in the PUSH TO FREEZE switch/light follow these simple steps:

- A. Grasp the lens with your thumb and forefinger and pull out.

- B. Remove the faulty lamp by pulling out the lamp puller (See Fig. 33).

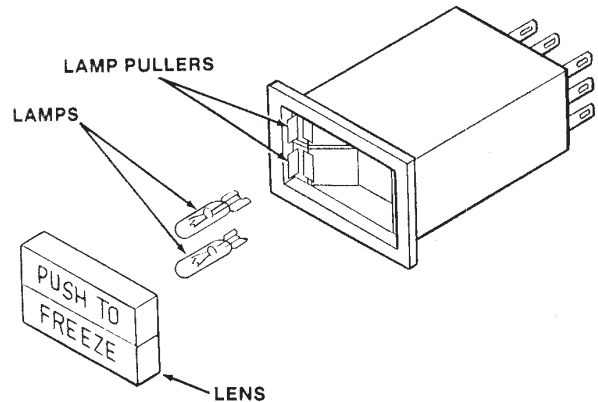

Figure 33. Push To Freeze Light/Switch Assembly

- C. To install the new lamp, line up the lamp end with the receptacle and push fully in.
- D. Reinstall the lens by pushing firmly in. When installed "PUSH TO" might be right side up.

NOTE

LED light bulbs require correct polarity. If the bulb does not illuminate, remove the bulb, turn 180° and replace.

5.3 CLEAN-OFF-SERVE ROCKER SWITCH REPLACEMENT

- A. Remove side panel.



WARNING

DISCONNECT FREEZER FROM ELECTRICAL SUPPLY SOURCE BEFORE SERVICING.

5.4 REPLACEMENT PARTS & REFERENCE DRAWINGS

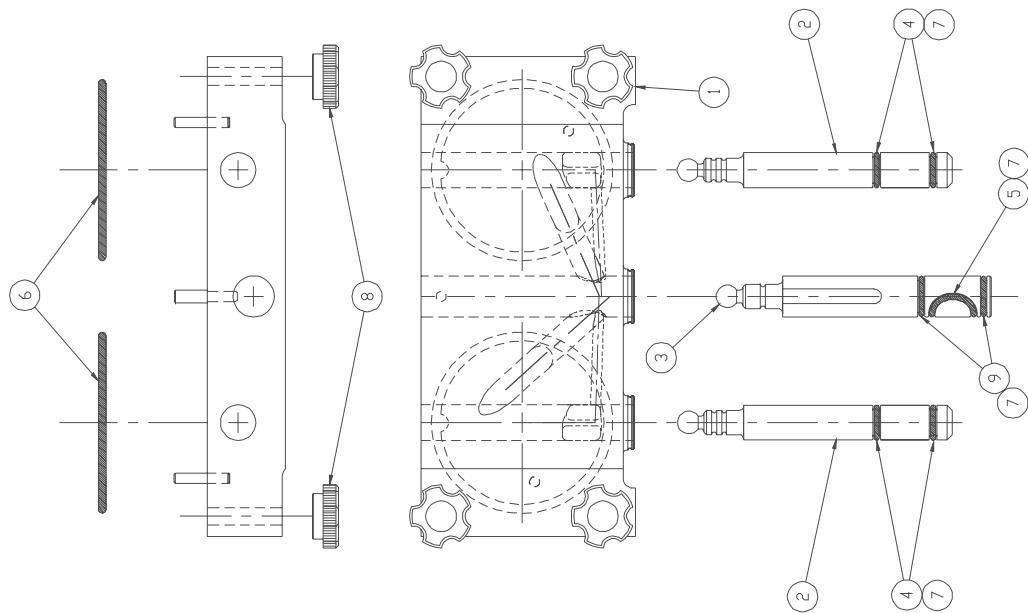
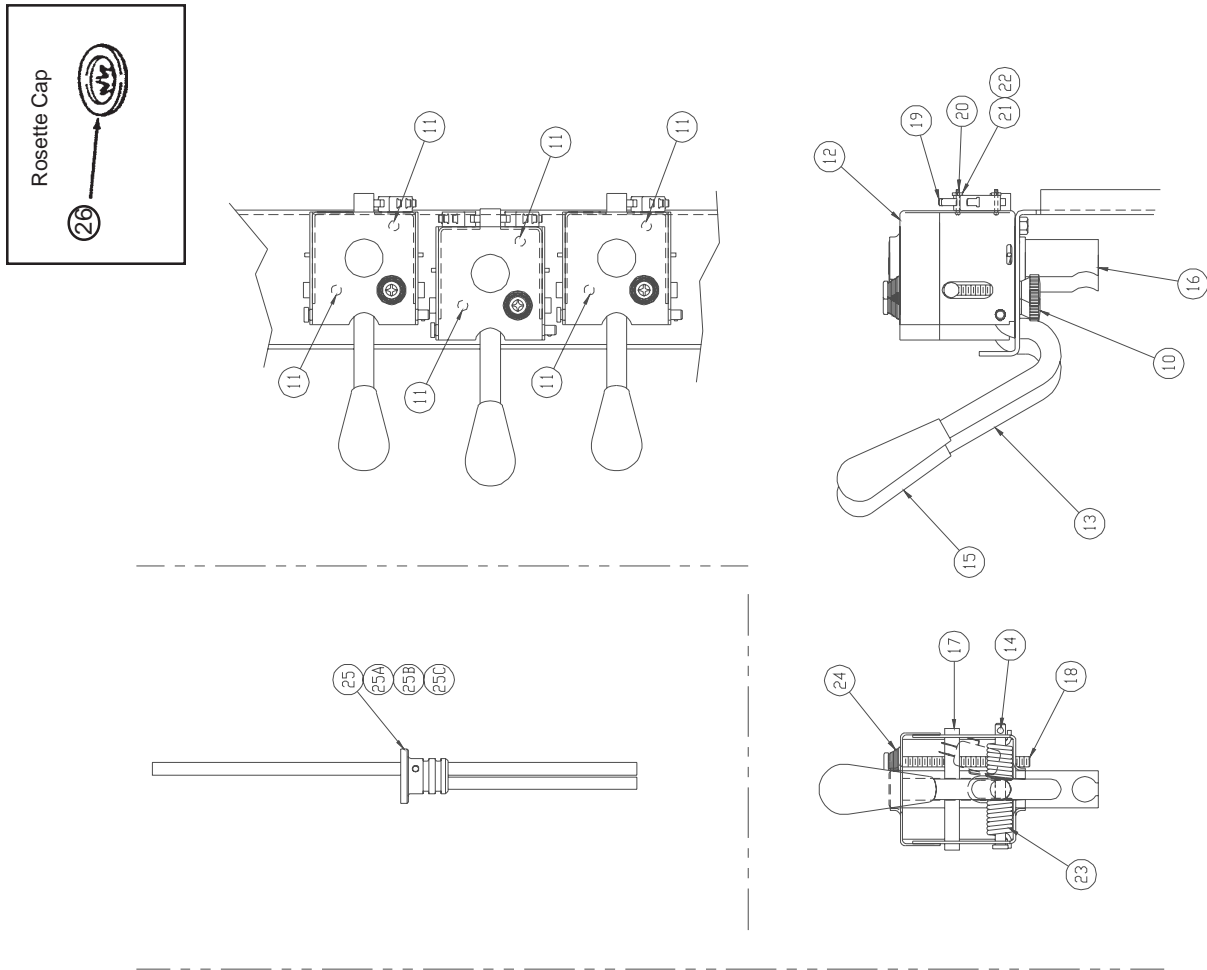

34. Spigot, Front Door and Auger Assembly

<u>Item</u>	<u>Stoelting PN</u>	<u>Qty</u>	<u>Description</u>
1	2177428	1	Door w/pins
2	3159696	2	Spigot, Outside
3	3158086	1	Spigot, Center
4	624598	4	O-Ring, 7/8 OD x 1/8 CS
5	624664	1	O-Ring 1-5/16 OD x 1-1/16 ID x 1/8 CS
6	625133	2	O-Ring 4.00" OD x .1875" CS
7	508135	As Reqd	Lube, Petro-Gel
8	482019	4	Knob with 3/8-16 (Black)
9	624614	2	O-Ring, 1 OD x 3/4 ID x 1/8 CS
10	482004	3	Knob
11	644094	6	Screw, Cap 1/4-20 x 3/8 Hex Hd
12	4158215	3	Glide Bracket Weldment
13	2158260	3	Handle
14	570961	3	Pin, Cotterless Clevis
15	428045	3	Knob, Black Plastic
16	2158082	3	Glide
17	1158080	3	Adjusting Bar
18	647995	3	Screw, Machine 1/4-20 x 3.50" Long
19	718773	4	Switch
20	647055	8	Screw, Machine #4-40 x .625" Long
21	538235	8	Nut, Hex #4-40
22	766917	8	Washer, Shakeproof #4
23	696048	2	Spring, Torsion (Outside Spigot)
23	696044	1	Spring Torsion (Center Spigot)
24	694247	3	Spring
25	1145194	2	Mix Inlet Reg. (1/4" Hole, Std Length)
25A	1146231	2	Mix Inlet Reg. (5/16" Hole, Std Length)
25B	1150832	2	Mix Inlet Reg. (1/4" Hole, Ext. Length)
25C	1150807	2	Mix Inlet Reg. (5/16" Hole, Ext. Length)
26	232734	3	Rosette Cap

ITEM	STOELTING PN	QTY	DESCRIPTION
1	396176	1	GASKET, FRONT EVAPORATOR RBR
2	3156795	2	AUGER
3	666786	2	SEAL, REAR WITH INSERT
4	3170644	2	FRONT AUGER SUPPORT MACHINED
5	314462	2	COVER, HOPPER INSULATED
6	584200-04B	4	PLUG, HOLE .375 MTG HOLE
7	1145194	1	MIX INLET REGULATOR
8	M830435	1	ADHESIVE INSULATION
9	624678	2	RING O 1-1/2 X1-1/8 X3/16 C-S
10	4177811	2	SIDE PANEL
11	464084	4	SOUND DAMPENING PNL 23.3X 25.3
12	3151169	1	UPPER BACK PANEL
13	3149108	1	LOWER PANEL ASSY
14	3177131	1	ACCESS PANEL WELDMENT
15	2170744	1	SPLASH PANEL
16	584191	2	PLUG HOLE .875 DIA MTG HOLE
17	647691	2	SCREW MACH 10-24 X 3/4 TRS HD
18	647653	16	SCREW MACH 10-24 X 3/8 TRS HD
19	647668	5	SCREW MACH 10-24 X 1/2 RD HD
20	381804	10	FLIGHT LOOSE PLASTIC AUGER #6
21	538912	2	NUT SPEED 10-24X47/64X9/16
22	422074	2	GROMMET RUBBER BLACK
23	694255	10	SPRING COMP
24	766948	4	WASHER SHAKEPROOF 10 ZINC
25	3172832	1	LOWER BACK PANEL, WC
26	714003	33 FT	STRIP 3/8 WIDE CORK/RUBBER
27	508135	AS REQ	LUBRICANT, PETRO-GEL 40Z.TUBES
28	314290	2	COVER SQUARE 4IN FOR OUTLET BX
29	647665	2	SCREW MACH 10-32 X 3/8 HX HD
30	3158261	1	HEADER PANEL
31	324803	1	DECAL, STOELTING LOGO
31	324804	1	DECAL, STOELTING SWIRL
31	324806	1	DECAL, A&W LOGO
32	4158293	1	FRONT SHROUD WELDMENT
33	266018	1	CLIP ADHESIVE BACKED "J"
34	741505	1	TOOL ALIGNMENT SCREWDRIVER
35	2149401	1	LOWER BACK PANEL, AC
36	324566	1	DECAL - WIRED ACCORDING TO
37	149003	2	BEARING FRONT AUGER, CELCON
38	266076	2	CLIP REFRIGERATOR 1/4 TURN
39	728106	3 FT	TAPE, FOAM 1" X 3/4"
40	647899	12	SCREW, MACH 1/4-20 X 3/8 TRS
41	2151924	1	DRIP TRAY ASSEMBLY
42	744254	1	DRIP TRAY INSERT
43	417006	1	GRATING GRID FOR DRIP TRAY

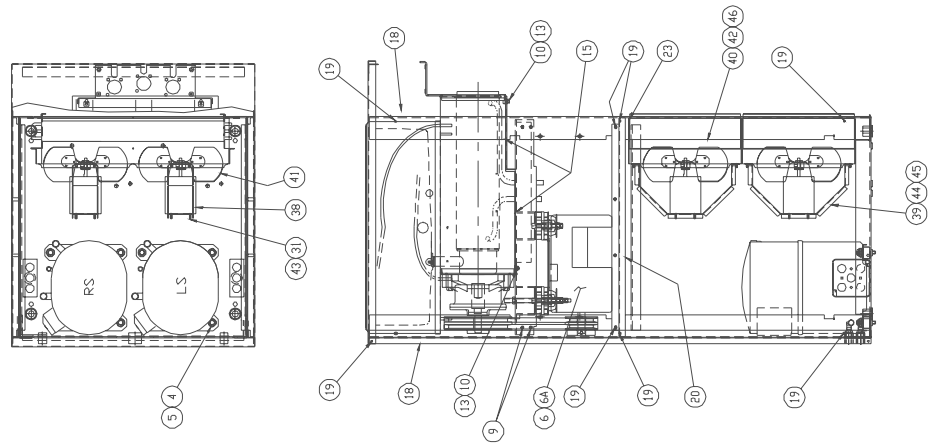
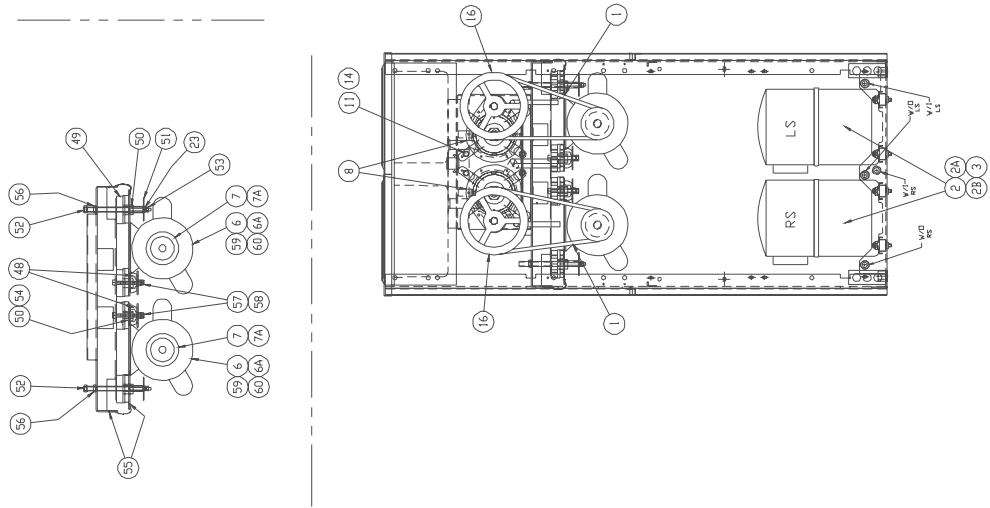
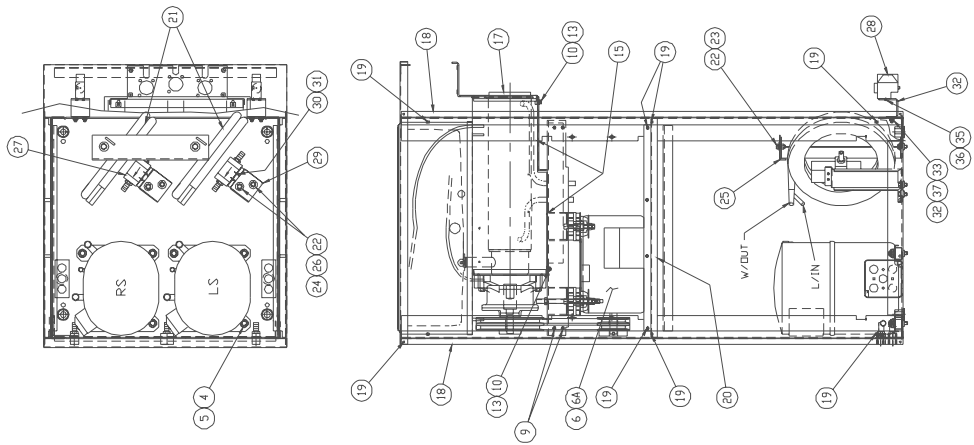

<u>Item</u>	<u>Stoelting PN</u>	<u>Qty</u>	<u>Description</u>	<u>Item</u>	<u>Stoelting PN</u>	<u>Qty</u>	<u>Description</u>
1	152294	4	Belt V, 39.2 O.L. x 38.3 P.L.	29	2172761	2	Water Valve Bracket (W/C Only)
2	282021-SV	2	Compressor (4231-18G, -38G)	30	644024	4	Screw Mach 8-32 x 1/4 Hx (W/C Only)
2A	282020-SV	2	Compressor (4231-109G, -309G)	31	766941	4	Washer Shakeproof #8 (W/C Only)
2B	282030	2	Compressor (4231-102G, -302G)	32	2172763	2	Pressure Switch Bracket (W/C Only)
3	422156	2	Grommet Kit with sleeves	33	538335	4	Nut Hex 1/4-20 x 7/16 Stl Zp
4	644371	8	Screw Cap 5/16-18 x 1-3/4 Hx	34	766456	4	Washer Round 5/8 x 9/32 Steel
5	767211	8	Washer Flat 5/16, 7/8 x 3/8 x 14GA	35	647393	4	Screw Mach 6-32 x 3/8 Rd Hd Ph
6	522844	2	Motor, 2HP (1 PH & 3 PH, 60 HZ) (SER.#0 - 16068)	36	766933	4	Washer Shakeproof 6 x 5/16
6	522856	2	Motor, 2 HP (1 PH & 3 PH, 60 HZ) (SER.#16069 Plus)	37	644106	4	Screw Cap 1/4-20 x 5/8 Hx Hd
6A	523082	2	Motor, 2HP (50 HZ)	38	522833	2	Fan Motor (A/C Only)
7	1145153	2	Pulley (1 PH & 3 PH, 60 HZ)	39	3171824	2	Bracket, Condenser (A/C Only)
7A	1147928	2	Pulley (50 HZ)	40	4154716	1	Condenser Shroud (A/C Only)
8	614232	2	Speed Reducer 5:2:1 Reduction	41	162067	2	Blade, Fan (A/C Only)
9	628046	16	Rivet Blind 1/4	42	284044	1	Condenser (A/C Only)
10	644091	4	Screw Cap 1/4-20 x 1/2 Hx Hd	43	538280	8	Nut, Hex #8-32 (A/C Only)
11	644605	8	Screw Cap 3/8-6 x 2 Hx Hd Zp	44	766948	8	Washer, Shakeproof #10 (A/C Only)
12	714006	36	1" x 100' Roll/Rubber	45	538297	8	Nut, Hex #10-24 (A/C Only)
13	766964	4	Washer Shakeproof 1/4 Zinc	46	649000-37	4	Screw, Self Tap 10-24 (A/C Only)
14	766982	8	Washer Shakeproof 3/8 Zinc	47	732133	2	Wire Nut (Crimp) (A/C Only)
15	M820072	.001	Sealant-White Adhesive	48	524075	4	Mount Motor Ring
16	2147034	2	Pulley, 7.00 PD Machined	49	524074	6	Mount Motor Bushing
17	4172774	1	Hopper & Evap. Foamed	50	221637	4	Bushing Support (Shaft End)
18	119421	4	Angle (Vertical Extrusion)	51	766566	8	Washer .406 ID x 2.5 OD x 14 GA
19	628038-04	16	Rivet 3/16 Dia. x .62 Lg.	52	1145141	2	Motor Adjusting Stud
20				53	538344	2	Nut Hex 5/16-18 x 1/2 Stl Zp
21	284104	2	Condenser (W/C Only)	54	1150893	2	Bushing Support (Opposite Shaft End)
22	644307	8	Screw Cap 5/16-18 x 3/4 (W/C Only)	55	649109	4	Screw Tap 10-16 x 1/2 Ind. Hx
23	538351	2	Nut Hex 5/16-18 Locking (W/C Only)	56	538395	2	Nut Hex 1/2-13 x 3/4 x 5/16 Zp
24	766073	6	Washer Lock 5/16 (W/C Only)	57	538360	4	Nut Hex Full 3/8-16 Zp
25	2172762	1	Condenser Joining Bracket (W/C Only)	58	538356	4	Nut Hex Locking Flange Zp
26	767205	6	Washer Flat 1/4 x 3/4 x 5/16 (W/C Only)	59	231083	2	Start Capacitor
				60	231082	2	Run Capacitor

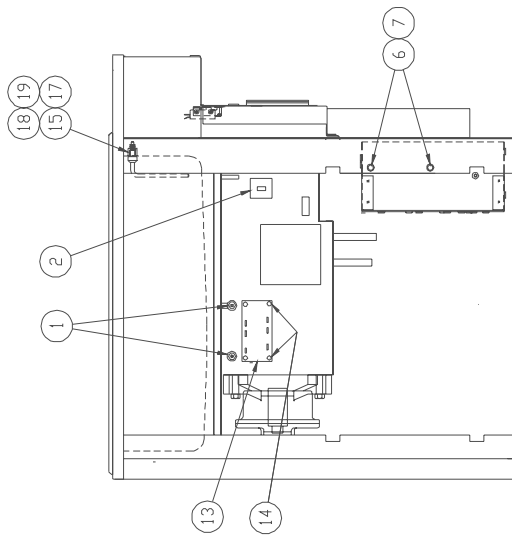
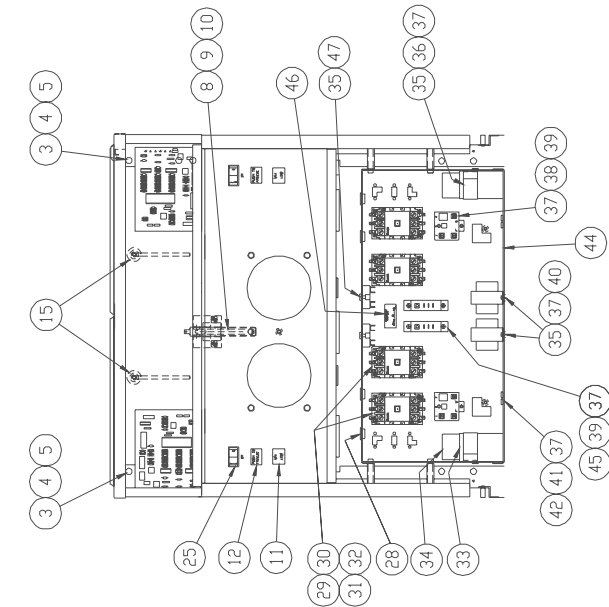
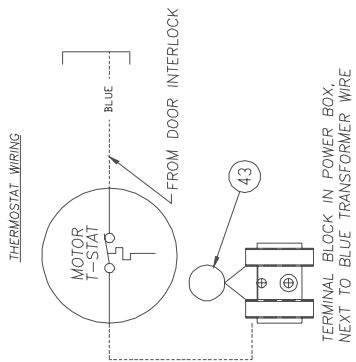
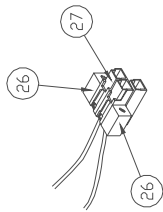
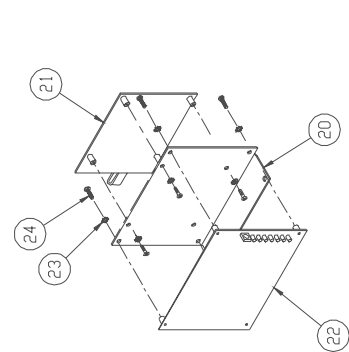

<u>Item</u>	<u>Stoelting P/N</u>	<u>Qty</u>	<u>Description</u>	<u>Item</u>	<u>Stoelting P/N</u>	<u>Qty</u>	<u>Description</u>
1	649109	4	Screw Tap 10-16 x 1/2 Ind. Hx	25	718750	2	Switch, Rocker
2	524091	2	Mount Adhesive Back 1 x 1 Plastic	26	732118	16	Terminal Panel Mount (Red)
3	647885	2	Screw Mach 1/4-20 x 1/2 Trs Hd	27	732119	2	Terminal Housing (Red)
4	538922	2	Nut Speed 1/4-20	28	223007	4	Bushing Snap 5/8ID 3/4 Mig.
5	766964	6	Washer Shakeproof 1/4 Zinc	29	295109	4	Contact Mag 3-Pole 24V
6	644195	4	Screw Cap 1/4-20 x 2 Hx Hd	30	766948	8	Washer Shakeproof 10 Zinc Plate
7	1172773	4	Spacer, 1.47 Long	31	644048	8	Screw Mach 10-24 x 1/2 Hx Hd
8	2158124-SV	1	Door Interlock Switch Assy	32	538913	8	Nut Speed 10-24 x 37/64 x 5/8
9	766949	2	Washer Shakeproof #10 Cntsink	33	231084	2	Capacitor, Run (4231-18G,-38G)
10	647671	2	Screw Mach 10-24 x 1/2 Fl Hd	34	231079	2	Capacitor, Start (4231-18G,-38G)
11	458105	2	Indicator, Mix Low	35	647513	8	Screw Mach 8-32 x 3/8 Rd Hd Ph
12	1154882	2	Switch, Push-To-Freeze Assembly	36	2141450	2	Capacitor Bracket 50 HZ
13	296179	2	Control Liquid Level 24V	37	766940	34	Washer Shakeproof 8 Zinc Plate
14	524087	8	Mount Dual Lock Circuit Spacer	38	618157	2	Relay, Motor Start (4231-18G,-38G)
15	538296	4	Nut Hex #10-24 x 3/8 SS	39	647529	10	Screw Mach 8-32 x 1/2 Rd Hd PH
16	538912	4	Nut Speed 10-24 x 47/64 x 9/16	40	744142	2	Transformer Assy
17	2172828	2	Mix Probe Assembly	41	647536	4	Screw Mach 8-32 x 5/8 Rd Hd Ph
18	766430	2	Washer Round	42	732019	2	Terminal Block 5 Contacts
19	1157996	2	Spacer	43	1141398	2	Varistor Assy 24 Volt
20	3158218	2	Control Board Bracket	44	4177141	1	Power Box Weldment
21	521721	2	Module, Control Power Board	45	739527	2	Timer, Interval 24 Vac
22	521554	2	Module, Control-Logic Board 608	46	1170811	1	Decal Clean Timer
23	647376	16	Screw, Machine #6-32 x 1/4" Lg.	47	732020	2	Terminal Block 8 Pole
24	766933	16	Washer, Shakeproof #6				

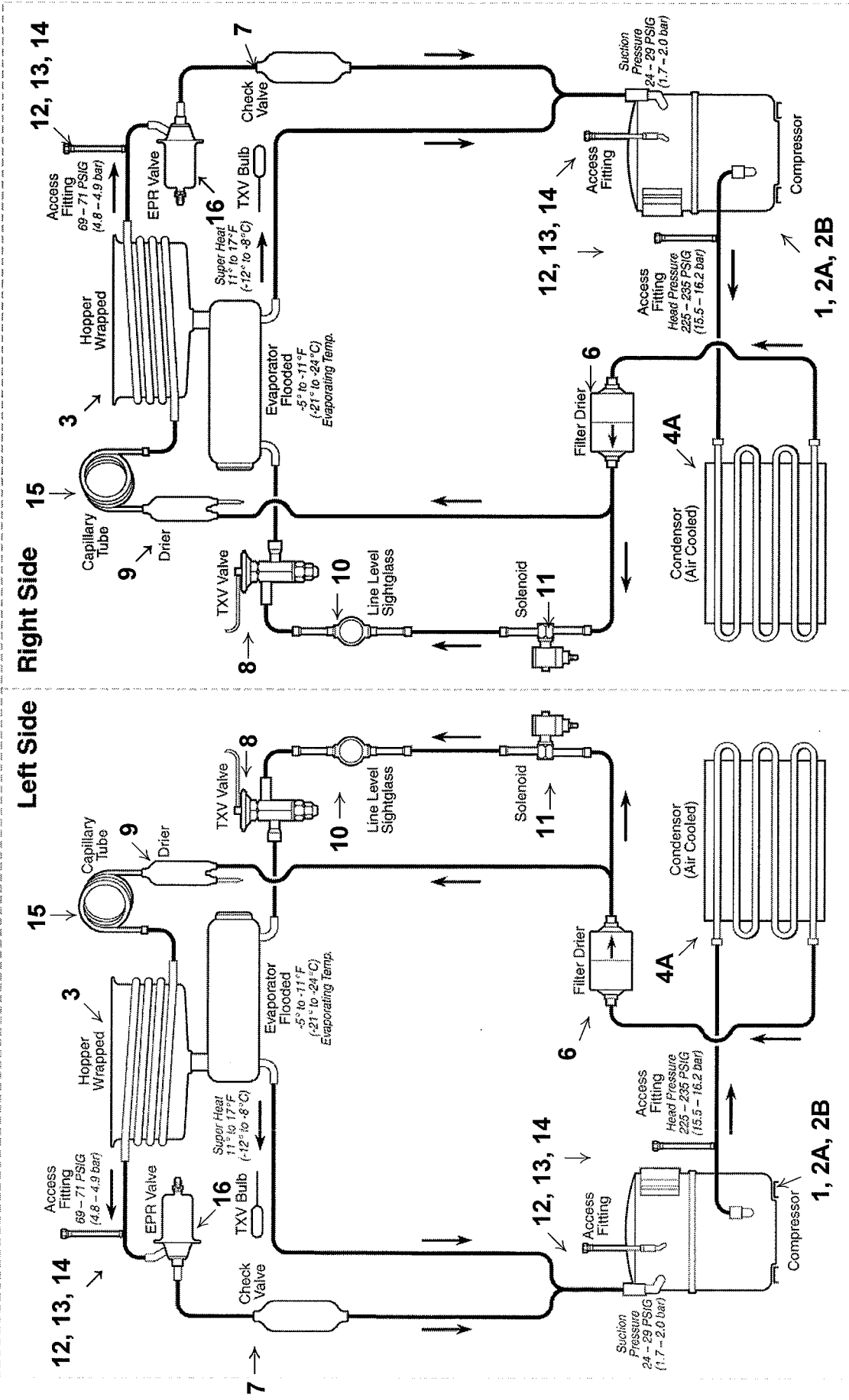

**New Style System (Model 4231G)
Air Cooled Version**

<u>Item</u>	<u>Stoelting P/N</u>	<u>Qty</u>	<u>Description</u>
1	282021-SV	2	Compressor (4231-18G, -38G)
2A	282020-SV	2	Compressor (4231-109G, -309G)
2B	282030	2	Compressor (4231-102G, -302G)
3	4172774	1	Hopper & Evaporator Assembly
4	284104	2	Condenser (W/C Only)
4A	284044	1	Condenser (A/C Only)
5	718686	2	Switch Pressure (W/C Only)
6	342008	2	Drier, Filter
7	762277	2	Check Valve (Magni-Chek)
8	762445	2	Expansion Valve
9	342020	2	Drier Refrigeration
10	458010	2	Indicator, Sight Glass
11	763455	2	Valve Solenoid
12	375813	6	Access Fitting Assembly
13	282085	6	Cap Quick Seal
14	762359	6	Valve Core
15	231101-SV	2	Capillary Tube
16	1158278	2	Valve, EPR

<u>Item</u>	<u>Stoelting PN</u>	<u>Qty</u>	<u>Description</u>
1	282021-SV	2	Compressor (4231-18G, -38G)
2A	282020-SV	2	Compressor (4231-109G, -309G)
2B	282030	2	Compressor (4231-102G, -302G)
3	4172774	1	Hopper & Evaporator Assembly
4	284104	2	Condenser (W/C Only)
4A	284044	1	Condenser (A/C Only)
5	718686	2	Switch Pressure (W/C Only)
6	342008	2	Drier, Filter
7	762277	2	Check Valve (Magni-Chek)
8	762445	2	Expansion Valve
9	342020	2	Drier Refrigeration
10	458010	2	Indicator, Sight Glass
11	763455	2	Valve Solenoid
12	375813	6	Access Fitting Assembly
13	282085	6	Cap Quick Seal
14	762359	6	Valve Core
15	231101-SV	2	Capillary Tube
16	1158278	2	Valve, EPR



WARRANTY SOFT SERVE / SHAKE FREEZERS

1. Scope:

Stoelting, LLC warrants to the first user (the “Buyer”) that the freezer cylinders, hoppers, compressors, drive motors, speed reducers, auger and auger flights of Stoelting soft serve / shake freezers will be free from defects in materials and workmanship under normal use and proper maintenance appearing within five (5) years, and that all other components of such equipment manufactured by Stoelting will be free from defects in material and workmanship under normal use and proper maintenance appearing within twelve (12) months after the date that such equipment is originally installed.

2. Disclaimer of Other Warranties:

THIS WARRANTY IS EXCLUSIVE; AND STOELTING HEREBY DISCLAIMS ANY IMPLIED WARRANTY OF MERCHANTABILITY OR FITNESS FOR PARTICULAR PURPOSE.

3. Remedies:

Stoelting’s sole obligations, and Buyer’s sole remedies, for any breach of this warranty shall be the repair or (at Stoelting’s option) replacement of the affected component at Stoelting’s plant in Kiel, Wisconsin, or (again, at Stoelting’s option) refund of the purchase price of the affected equipment, and, during the first twelve (12) months of the warranty period, deinstallation/reinstallation of the affected component from/into the equipment. Those obligations/remedies are subject to the conditions that Buyer (a) signs and returns to Stoelting, upon installation, the Checklist/Warranty Registration Card for the affected equipment, (b) gives Stoelting prompt written notice of any claimed breach of warranty within the applicable warranty period, and (c) delivers the affected equipment to Stoelting or its designated service location, in its original packaging/crating, also within that period. Buyer shall bear the cost and risk of shipping to and from Stoelting’s plant or designated service location.

4. Exclusions and Limitations:

This warranty does not extend to parts, sometimes called “wear parts”, which are generally expected to deteriorate and to require replacement as equipment is used, including as examples but not intended to be limited to o-rings, auger seals, auger support bushings and drive belts. All such parts are sold

AS IS.

Further, Stoelting shall not be responsible to provide any remedy under this warranty with respect to any component that fails by reason of negligence, abnormal use, misuse or abuse, use with parts or equipment not manufactured or supplied by Stoelting, or damage in transit.

THE REMEDIES SET FORTH IN THIS WARRANTY SHALL BE THE SOLE LIABILITY STOELTING AND THE EXCLUSIVE REMEDY OF BUYER WITH RESPECT TO EQUIPMENT SUPPLIED BY STOELTING; AND IN NO EVENT SHALL STOELTING BE LIABLE FOR ANY INCIDENTAL OR CONSEQUENTIAL DAMAGES, WHETHER FOR BREACH OF WARRANTY OR OTHER CONTRACT BREACH, NEGLIGENCE OR OTHER TORT, OR ON ANY STRICT LIABILITY THEORY.