



Model 4231
OPERATORS MANUAL

Manual No. 513516

Jan. 1988

This manual provides basic information about the machine. Instructions and suggestions are given covering its operation and care.

The illustrations and specifications are not binding in detail. We reserve the right to make changes to the machine without notice, and without incurring any obligation to modify or provide new parts for machines built prior to date of change.

DO NOT ATTEMPT to operate the machine until instructions and safety precautions in this manual are read completely and are thoroughly understood. If problems develop or questions arise in connection with installation, operation, or servicing of the machine, contact Stoelting.



stoeltingfoodservice.com

Stoelting Foodservice Equipment
502 Highway 67
Kiel, WI 53042-1600
U.S.A.

Main Tel: 800.558.5807
Fax: 920.894.7029

Customer Service: 888.429.5920
Fax: 800.545.0662
Email: foodservice@stoelting.com

© 2014 PW Stoelting, LLC

A Few Words About Safety

Safety Information

Read and understand the entire manual before operating or maintaining Stoelting equipment.

This manual provides the operator with information for the safe operation and maintenance of Stoelting equipment. As with any machine, there are hazards associated with their operation. For this reason safety is emphasized throughout the manual. To highlight specific safety information, the following safety definitions are provided to assist the reader.

The purpose of safety symbols is to attract your attention to possible dangers. The safety symbols, and their explanations, deserve your careful attention and understanding. The safety warnings do not by themselves eliminate any danger. The instructions or warnings they give are not substitutes for proper accident prevention measures.

If you need to replace a part, use genuine Stoelting parts with the correct part number or an equivalent part. We strongly recommend that you do not use replacement parts of inferior quality.



Safety Alert Symbol:

This symbol Indicates danger, warning or caution. Attention is required in order to avoid serious personal injury. The message that follows the symbol contains important information about safety.

Signal Word:

Signal words are distinctive words used throughout this manual that alert the reader to the existence and relative degree of a hazard.



The signal word “WARNING” indicates a potentially hazardous situation, which, if not avoided, may result in death or serious injury and equipment/property damage.



The signal word “CAUTION” indicates a potentially hazardous situation, which, if not avoided, may result in minor or moderate injury and equipment/property damage.

CAUTION

The signal word “CAUTION” not preceded by the safety alert symbol indicates a potentially hazardous situation, which, if not avoided, may result in equipment/property damage.

NOTE (or NOTICE)

The signal word “NOTICE” indicates information or procedures that relate directly or indirectly to the safety of personnel or equipment/property.

TABLE OF CONTENTS

Section	Description	Page
1	INTRODUCTION	
1.1	Description	4
1.2	Specifications	5
2	INSTALLATION INSTRUCTIONS	
2.1	Safety Precautions	6
2.2	Shipment and Transit	7
2.3	Freezer Installation	7
2.4	Electrical Connections	8
3	INITIAL SET-UP AND OPERATION	
3.1	Operator's Safety Precautions	9
3.2	Operating Controls and Indicators	9
3.3	Sanitizing	10
3.4	Freeze Down and Operation	11
3.5	Mix Information	12
3.6	Removing Mix from Freezer	13
3.7	Cleaning the Freezer	13
3.8	Disassembly of Freezer Parts	14
3.9	Cleaning the Freezer Parts	15
3.10	Sanitize Freezer and Freezer Parts	16
3.11	Assembly of Freezer	16
3.12	Routine Cleaning	17
4	MAINTENANCE INSTRUCTIONS	
4.1	Preventive Maintenance	18
4.2	Freeze-up	19
4.3	Air Filter and Condenser Service	19
4.4	Extended Storage	19
4.5	Troubleshooting	19-20
5	REPLACEMENT PARTS	
5.1	How to Order Parts	21
5.2	Push To Freeze Light/Switch Lamp Replacement	21

LIST OF ILLUSTRATIONS

Figure	Title	Page
1	Model 4231 Freezer	4
2	Specifications	4
3	Warning Label Locations	6
4	Space and Ventilation Requirements	7
5	Leveling Freezer	7
6	Leg Adjustment	7
7	Danger Decal	8
8	Connecting Permanent Wiring	8
9	Controls	9
10	Mix Inlet Regulator	10
11	Sanitizing Procedure	11
12	Clean Control	11
13	Sanitizing Hopper	11
14	Spigot Opened and Solution Draining	11
15	Pouring the Mix	12
16	Dispensing Product	12
17	Skimming the Foam	13
18	Removing Mix Inlet Regulator	13
19	Draining Mix	13
20	Auger Flight Wear and Front Auger Support Wear	14
21	Removing Front Door	14
22	Removing Spigot	14
23	Removing Auger Supports	15
24	Auger Shafts	15
25	Removing "O" Ring	15
26	Cleaning Freezer Barrel	15
27	Exploded View of Auger	16
28	Exploded View of Front Door	17
29	Installing Mix Inlet Regulators	17
30	Skimming Hopper	18
31	Sanitizing Mix Inlet Regulators (Carburetor)	18
32	Push To Freeze Light/Switch Assembly	21
33	Spigot, Front Door and Auger Assembly	22

SECTION 1 INTRODUCTION

1.1 DESCRIPTION

The Stoelting® 4231 counter freezer is gravity fed. The freezer is equipped with fully automatic controls to provide a uniform product. The freezer is designed to operate with almost any type of commercial soft serve or non-dairy mixes available, including ice milk, ice cream, yogurt, and frozen dietary desserts.

The freezer is designed to be used with both barrels in operation. If you desire to use one barrel only, the freezer must be cleaned, sanitized and filled with fresh mix daily. For more information call your authorized Stoelting Serviceman.

This manual is designed to assist qualified service personnel and operators in the installation, operation and maintenance of the Stoelting Model 4231 gravity freezer.

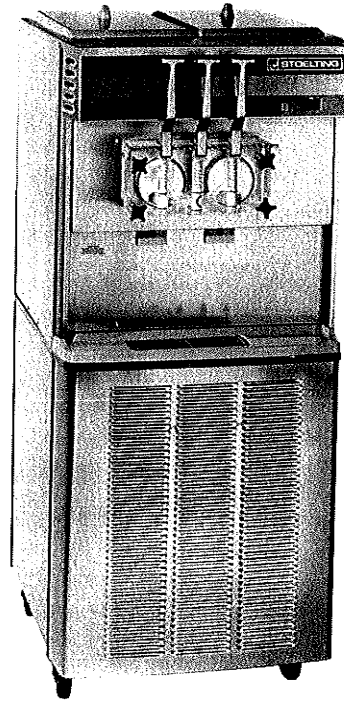

Figure 1. Model 4231 Freezer

1.2 SPECIFICATIONS

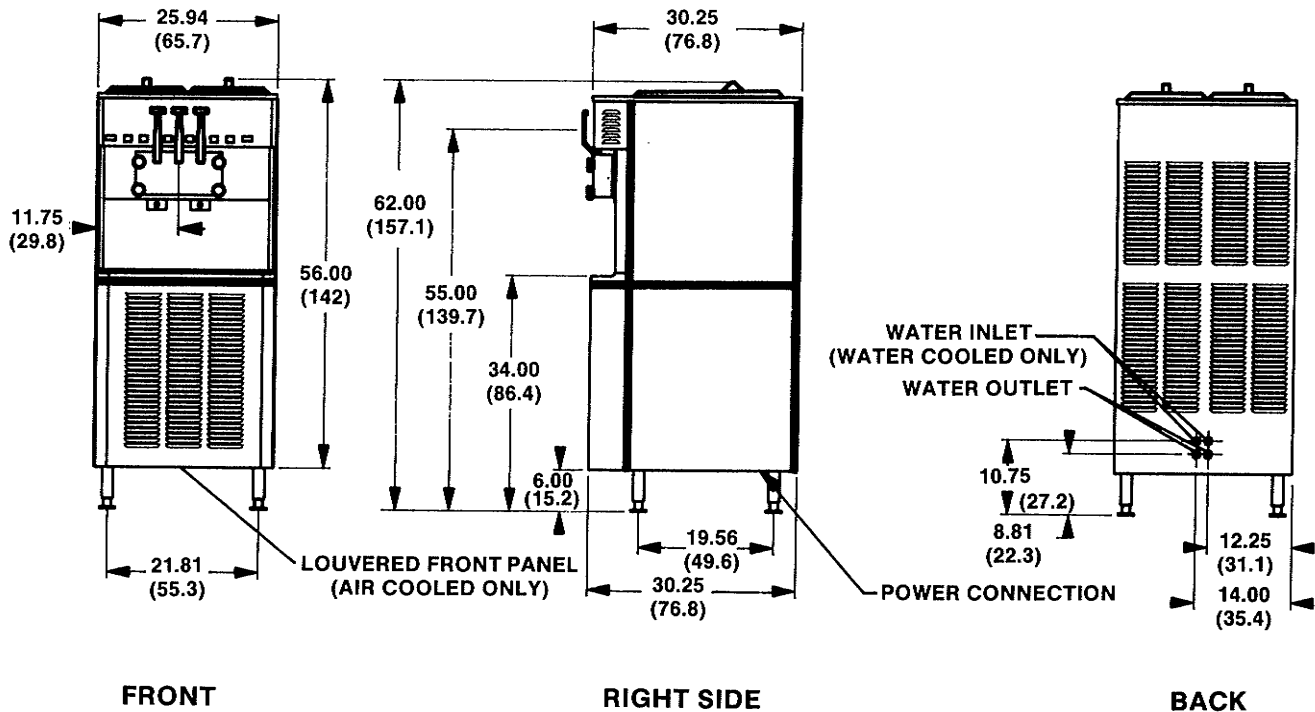

Figure 2. Specifications

(Figures in parenthesis are centimeters)

1.2 SPECIFICATIONS

MODEL 4231 FLOOR MODEL GRAVITY FREEZER

DIMENSIONS

Freezer: 26.00" (66.0 cm) wide x 30.25" (76.8 cm) deep x 62.00" (157.1 cm) high
Crated: 38.00" (96.5 cm) wide x 64.00" (162.5 cm) deep x 70.00" (178.0 cm) high

WEIGHT

Freezer: 640 lbs. (291 kg) Crated: 815 lbs. (370 kg)

ELECTRICAL

1 phase, 208/230 dual voltage **(USE TWO SEPARATE 30 AMP CIRCUIT BREAKERS)**
2 Drive Motors (2 HP each), 7800 B.T.U.H.* Compressor

3 phase, 208/230 dual voltage **(USE TWO SEPARATE 20 AMP CIRCUIT BREAKERS)**
2 Drive Motors (1-1/2 HP each), 7800 B.T.U.H.* Compressor
750 B.T.U.H. Hopper Compressor

*Under normal operating conditions.

COOLING

Air cooled requires 6" (15.2 cm) clearance for all louvered panels. Water cooled requires 3/8" pipe or 1/2" inside diameter copper water line be installed for adequate water supply.

HOPPER CAPACITY

Two hoppers, 5.6 gallons (21 liters) each, refrigerated and insulated.

SECTION 2 INSTALLATION INSTRUCTIONS

2.1 SAFETY PRECAUTIONS

Do not attempt to operate the freezer until the safety precautions and operating instructions in this manual are read completely and are thoroughly understood.

Take notice of all warning labels on the freezer (Fig. 3). The labels have been put there to help maintain a safe working environment. The labels have been designed to withstand washing and cleaning. All labels must remain legible for the life of the freezer.

Labels should be checked periodically to be sure they can be recognized as warning labels.

If danger, warning or caution labels are needed, indicate the part number, type of label, location of label, and quantity required along with your address and mail to:

STOELTING, INC.
ATTENTION: Customer Service
P.O. Box 127
Kiel, Wisconsin 53042-0127

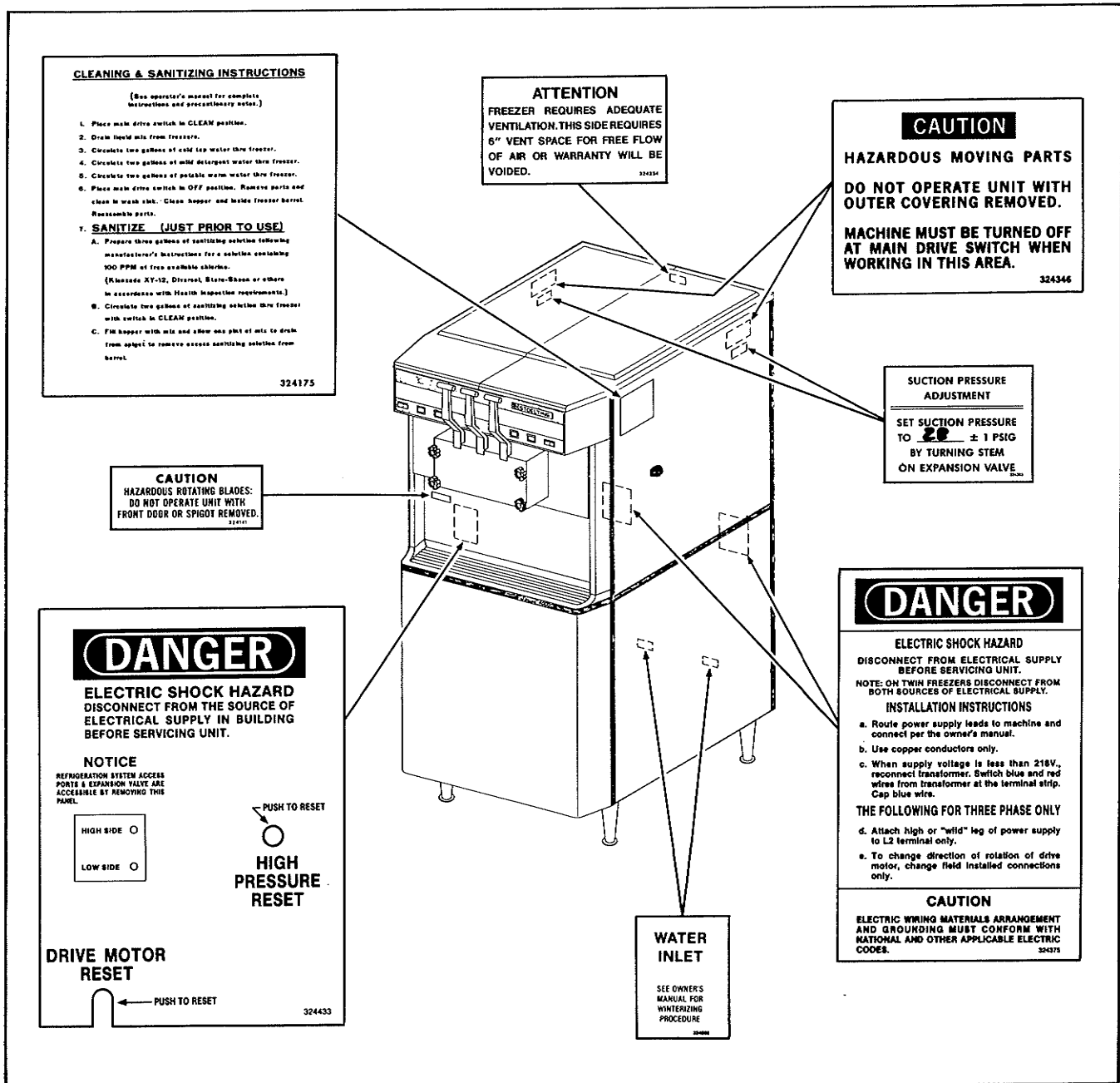

Figure 3. Warning Label Locations

2.2 SHIPMENT AND TRANSIT

The freezer has been assembled, operated and inspected at the factory. Upon arrival at the final destination, the freezer must be checked for any damage which may have occurred during transit.

With the method of packaging used, the freezer should arrive in excellent condition. **THE CARRIER IS RESPONSIBLE FOR ALL DAMAGE IN TRANSIT, WHETHER VISIBLE OR CONCEALED.** Do not pay the freight bill until the freezer has been checked for damage. Have the carrier note any visible damage on the freight bill. If concealed damage and/or shortage is found later, advise the carrier within 10 days and request inspection. The customer must place claim for damages and/or shortages in shipment with the carrier. **Stoelting, Inc. cannot make any claims against the carrier.**

2.3 FREEZER INSTALLATION

CAUTION

Failure to install the freezer within recommended limits will result in poor performance of the system, premature component failure and cancellation of the warranty.

Installation of the freezer involves moving the unit close to its permanent location, removing all protective packaging, setting in place and cleaning.

CAUTION

Remove lower front panel before removing freezer from skid.

- A. The freezer requires adequate ventilation. A minimum of 6" (15 cm) of vent space is required for free flow of cooling air at the front and back and on side(s) with louvered panel(s) (Fig. 4).

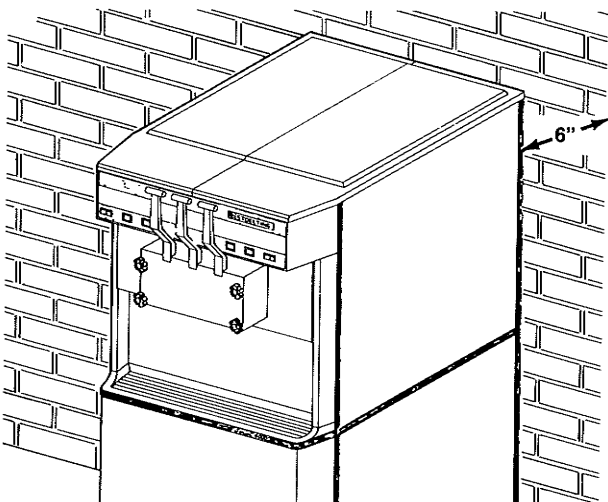

Figure 4. Space and Ventilation Requirements

CAUTION

Failure to provide adequate ventilation will void warranty!

- B. The unit is shipped without legs installed. To install the legs, lift and support the unit while screwing the four legs into the bottom of the frame at each corner.
- C. Accurate leveling is necessary for correct drainage of freezer barrel to insure correct over-run and flow. Place a spirit level on top of the freezer at each corner to check for level condition (Fig.5). If adjustment is necessary, level the freezer by turning the bottom part of each leg in or out (Fig. 6).

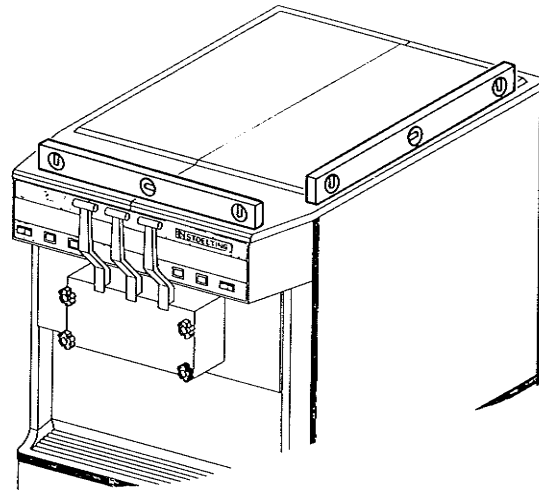

Figure 5. Leveling Freezer

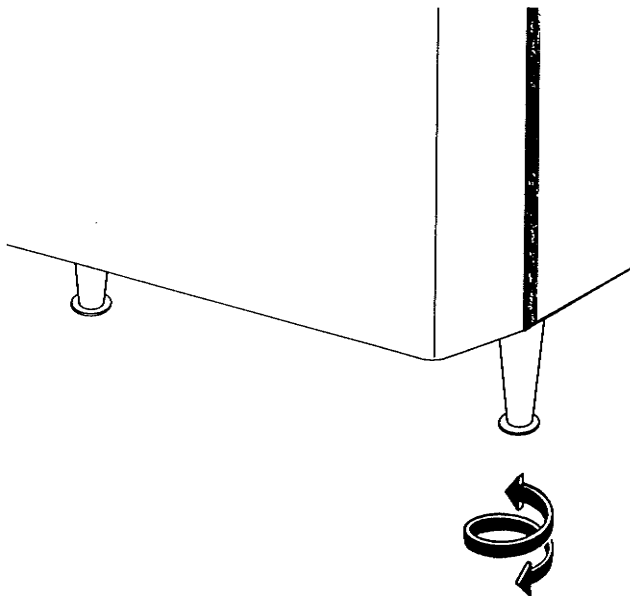

Figure 6. Leg Adjustment

2.4 ELECTRICAL CONNECTIONS



WARNING

BEFORE INSTALLATION OF ANY CABLE IN THE FREEZER, DISCONNECT THE FREEZER FROM ITS ELECTRICAL SUPPLY SOURCE.



CAUTION

Route electrical cable so that it cannot be accidentally damaged by pinching, crushing, etc.

- A. Connect freezer to a properly grounded 208/230 volt (AC), source of electricity.
- B. To access electrical box first remove front middle panel by lifting up, out and down. Then remove the four screws holding the inner panel and remove.
- C. For proper electrical connections, refer to Figure 7.

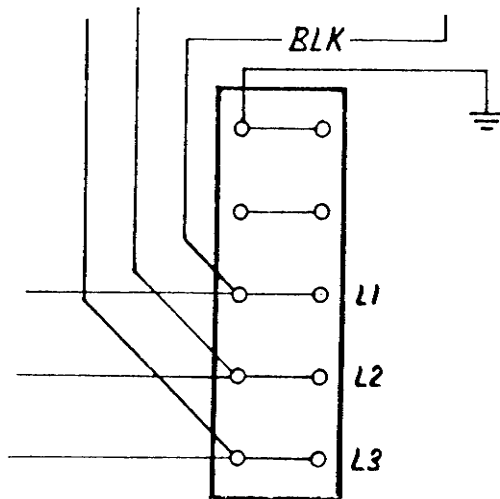

Figure 7. Connecting Permanent Wiring

NOTE

When supply voltage is less than 218V, reconnect transformer. Switch blue and red wires from transformer at the terminal strip and cap blue wire.

NOTE

- D. Please read decal located on lower electrical box cover (Fig. 8).

The model 4231 freezer is two individual freezers in a common enclosure. **EACH SIDE MUST BE CONNECTED INDIVIDUALLY. EACH SIDE MUST HAVE ITS OWN ELECTRICAL SUPPLY.** When making the electrical supply connections, **YOU MUST MAINTAIN STRAIGHT POLARITY FROM SIDE TO SIDE.**

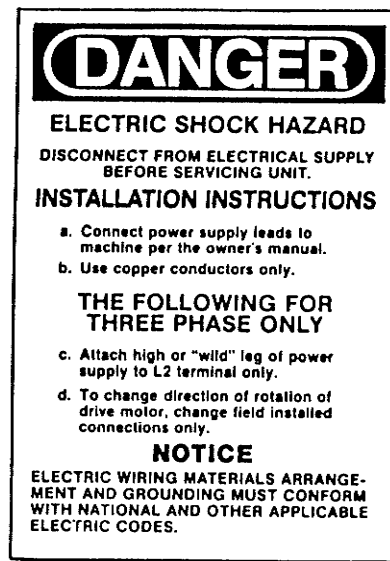

Figure 8. Danger Decal

SECTION 3 INITIAL SET-UP AND OPERATION

3.1 OPERATOR'S SAFETY PRECAUTIONS

SAFE OPERATION IS NO ACCIDENT; Observe these rules:

- A. **Know the freezer.** Read and understand the Operating Instructions.
- B. **Notice all warning labels on the freezer.**
- C. **Wear proper clothing.** Avoid loose fitting garments, and remove watches, rings or jewelry which could cause a serious accident.
- D. **Maintain a clean work area.** Avoid accidents by cleaning up the area and keeping it clean.
- E. **Stay alert at all times.** Know which switch, push button or control you are about to use and what effect it is going to have.
- F. **Disconnect electrical cord for maintenance.** Never attempt to repair or perform maintenance

on the freezer until the main electrical power has been disconnected.

- G. **Do not operate under unsafe operating conditions.** Never operate the freezer if unusual or excessive noise or vibration occurs.

3.2 OPERATING CONTROLS AND INDICATORS

Before operating the freezer, it is required that the operator know the function of each operating control. Refer to Figure 9 for the location of the operating controls on the freezer.

WARNING

THE CLEAN-OFF-ON SWITCH MUST BE PLACED IN THE OFF POSITION WHEN DISASSEMBLING FOR CLEANING OR SERVICING. THE FREEZER MUST BE DISCONNECTED FROM ELECTRICAL SUPPLY BEFORE REMOVING ANY ACCESS PANEL.

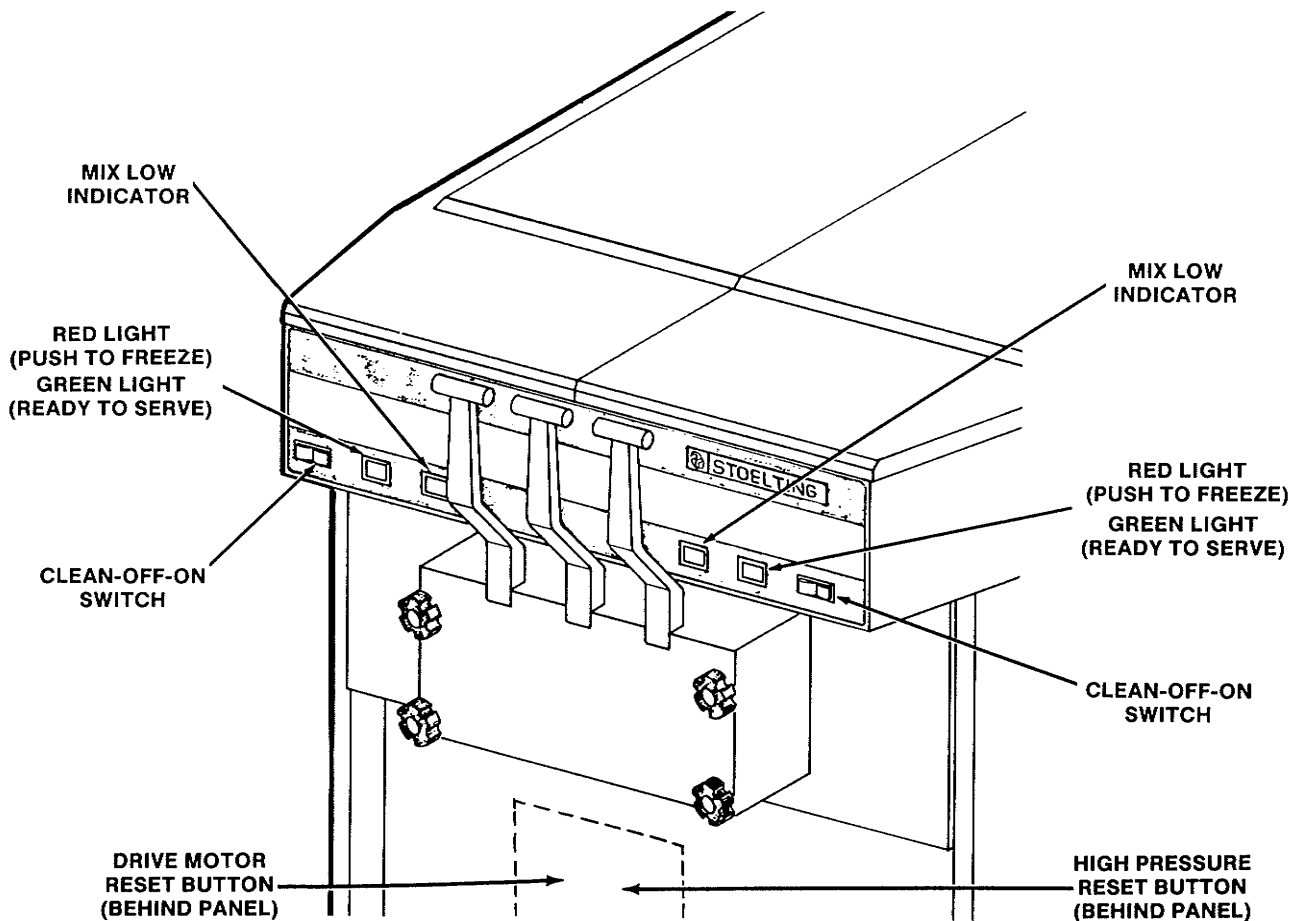

Figure 9. Controls

A. SPIGOT SWITCH

When the spigot handle is opened the SPIGOT switch will start the auger drive and refrigeration systems. When the spigot handle is closed, the drive motor and compressor will remain on until the product in the barrel reaches the proper consistency.

B. CLEAN-OFF-ON SWITCH

The CLEAN-OFF-ON switch is a three position rocker switch used to control the operation of the refrigeration system and auger. When the switch is placed in the CLEAN position, the refrigeration system will be off and the auger **will** rotate for cleaning.

When the switch is placed in the OFF position, the refrigeration system and auger **will not** operate.

When the switch is placed in the ON position, the refrigeration system and auger **will** operate automatically. The switch should be placed in the ON position for normal operation.

C. PUSH TO FREEZE SWITCH

The illuminating PUSH TO FREEZE switch is used to start the freezing cycle. During initial freeze down, the CLEAN-OFF-ON rocker switch is placed in the ON position. Then the PUSH TO FREEZE switch is pressed until the drive motor and compressor come "ON."

NOTE

After the gearmotor starts, there is a 3 second delay before the compressor starts.

During the normal operation, the red PUSH TO FREEZE switch will illuminate after the freezer has been idle for the pre-set time. Before drawing product, press the red PUSH TO FREEZE switch if it is illuminated. Wait until the green lens is illuminated before dispensing.

D. GREEN LENS

The green lens is used to indicate that the product has reached the proper consistency and is ready to be dispensed.

NOTE

If the PUSH TO FREEZE lens is illuminated. Push the PUSH TO FREEZE switch and wait until the green lens illuminates before dispensing.

NOTE

Failure to refill hopper immediately may result in operational problems.

3.3 SANITIZING

Sanitizing must be done after the freezer is clean and just before the hopper is filled with mix. **Sanitizing the night before is not effective.** However, you should always clean the freezer and parts after using it.



WARNING

THE UNITED STATES DEPARTMENT OF AGRICULTURE AND THE FOOD AND DRUG ADMINISTRATION REQUIRE THAT ALL CLEANING AND SANITIZING SOLUTIONS USED WITH FOOD PROCESSING EQUIPMENT BE CERTIFIED FOR THIS USE.

When sanitizing the freezer, refer to local sanitary regulations for applicable codes and recommended sanitizing products and procedures. The frequency of sanitizing must comply with local health regulations. Mix sanitizer according to manufacturer's instructions to provide a 100 parts per million strength solution. Mix sanitizer in quantities of no less than 2 gallons (7.5 liters) of 120° F water. Allow sanitizer to contact the surfaces to be sanitized for 5 minutes. Any sanitizer must be used only in accordance with the manufacturer's instructions.



CAUTION

Prolonged contact of sanitizer with freezer may cause corrosion of stainless steel parts.

In general, sanitizing may be conducted as follows:

- A. Push the mix inlet regulator fully into hopper (Fig. 10).

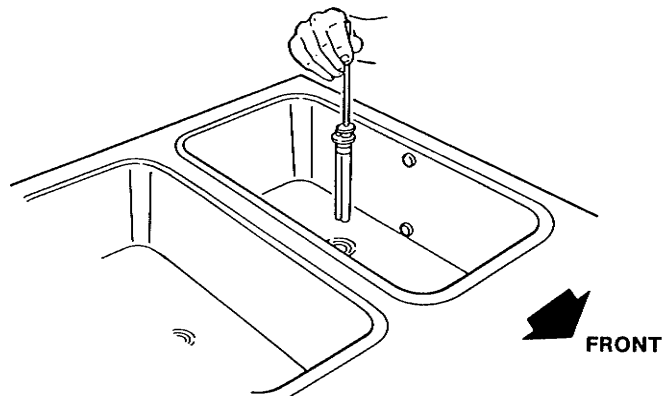

Figure 10. Mix Inlet Regulator

- B. Prepare 2 gallons (7.5 liters) of sanitizing solution following manufacturer's instructions. Pour into hopper with mix inlet regulator in place (Fig. 11).

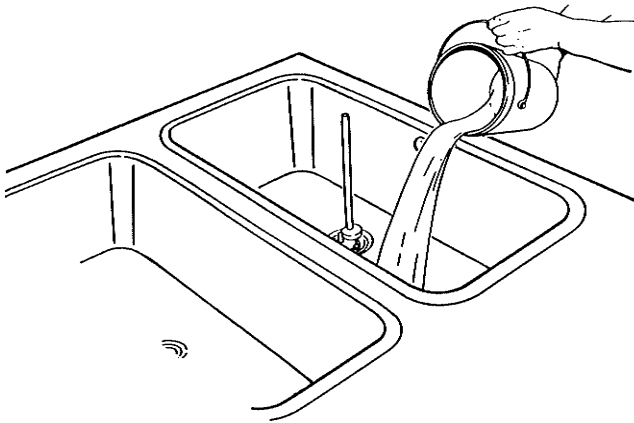

Figure 11. Sanitizing Procedure

- C. Place the CLEAN-OFF-ON rocker switch in the CLEAN position. Check for leaks around the front door seal (Fig. 12).

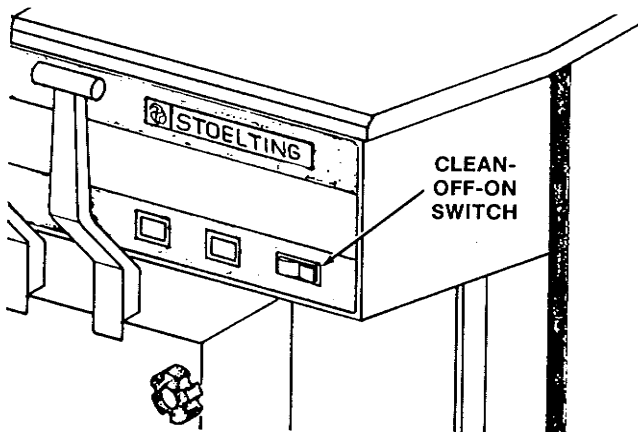

Figure 12. Clean Control

- D. Clean sides of hopper, mix inlet regulator and underside of hopper cover using a sanitized soft bristle brush dipped in the sanitizing solution (Fig. 13).

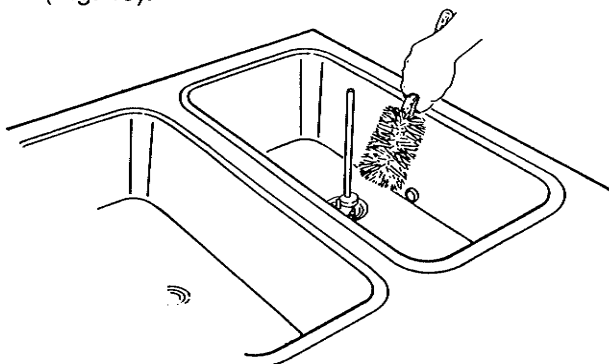

Figure 13. Sanitizing Hopper

- E. After five minutes, place a bucket under the spigots and open all three spigots to drain sanitizing solution. When solution has drained,

place the CLEAN-OFF-ON switch in the OFF position. Allow the freezer barrel to drain completely (Fig. 14).

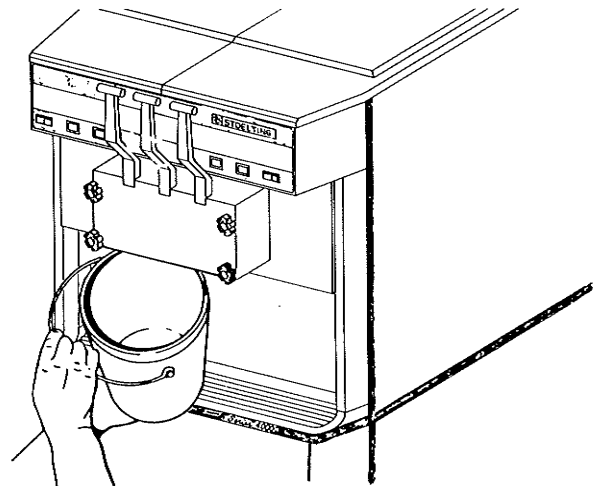

Figure 14. Spigot Opened and Solution Draining

3.4 FREEZE DOWN AND OPERATION

This section covers the recommended operating procedures to be followed for the safe operation of the freezer.

NOTE

If you desire to use one barrel only, refer to cleaning instructions 3.7 on page 13.

- Sanitize just prior to use.
- Place the CLEAN-OFF-ON switch in the OFF position.
- With spigots open, pour approximately 1 gallon (3.8 liters) of mix into the hopper. Allow the mix to flush out about 8 ounces (0.23 liters) of sanitizing solution and liquid mix. Close the spigot.
- Fill hoppers with approximately 6-1/2 gallons (11.4 liters) of pre-chilled (40°F or 4°C) mix.

CAUTION

Do not overfill the hopper. Mix level must not be higher than 2" (5 cm) from the top of the air inlet tube on the mix inlet regulator.

- The freezer barrel will automatically fill until it is about 1/2 full (about 3 min.). If freezer barrel does not fill, check for obstruction in the mix inlet regulator. If freezer barrel fills over 1/2 full, check for leaks at the mix inlet regulator "O" Ring, check if the mix inlet regulator was installed correctly, or that the freezer is level.

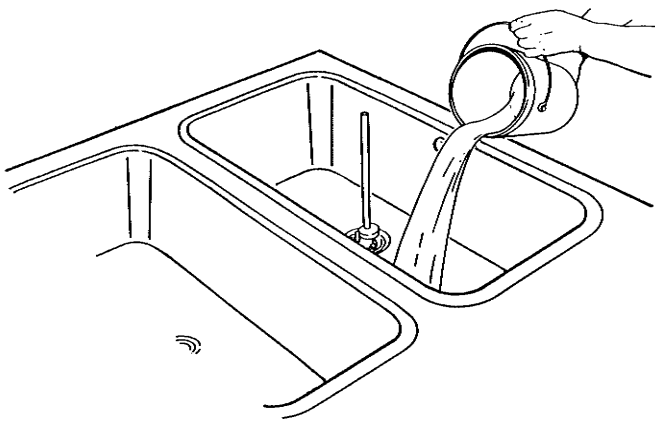

Figure 15. Pouring the Mix

- F. Place the CLEAN-OFF-ON rocker switch in the ON position, then press PUSH TO FREEZE switch until the drive motor and compressor come ON.

NOTE

After the gearmotor starts, there is a 3 second delay before the compressor starts.

- G. After about 6 to 10 minutes the freezer will shut OFF and the green lens will illuminate. The product is ready to serve. Freeze down time may be longer for some frozen diet dessert mixes.
- H. For normal dispensing, move the spigot handle open 60° (Fig. 16).

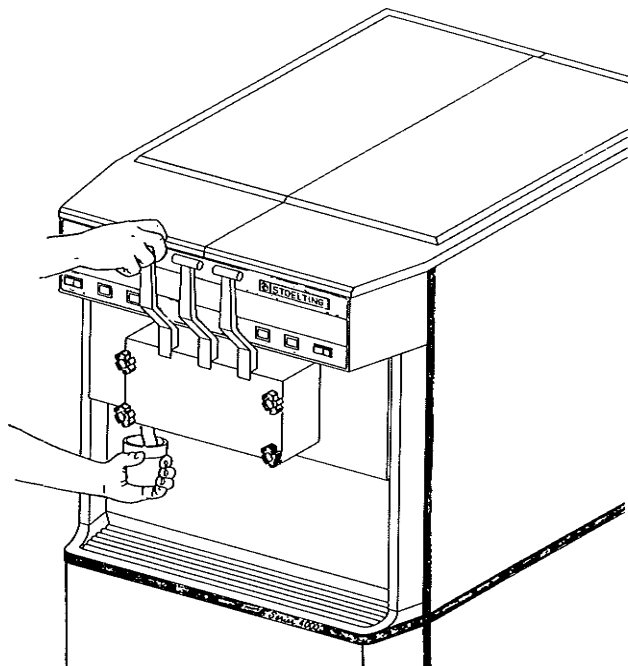

Figure 16. Dispensing Product

⚠ CAUTION

Refrigeration is automatically activated when the spigot is opened. Close the spigot completely after dispensing.

- I. The freezer is designed to dispense the product at a reasonable draw rate. If the freezer is overdrawn, the result is a soft product or a product that will not dispense at all. If this should occur, allow the freezer to run for approximately 30 seconds before dispensing additional product. After a while the operator will sense or feel when the freezer is beginning to fall behind, and will slow down on the rate of draw so as not to exceed the capacity.
- J. **Do not** operate the freezer when the level indicator shows the hopper is empty.

3.5 MIX INFORMATION

Mix can vary considerably from one manufacturer to another. Differences in the amount of butter-fat content and quantity and quality of other ingredients have a direct bearing on the finished frozen product. A change in freezer performance that cannot be explained by a technical problem may be related to the mix.

Proper product serving temperature varies from one manufacturer's mix to another. Mixes should provide a satisfactory product in the 18° to 20° F (-7° to -6° C) range.

When checking the temperature, stir the thermometer in the frozen product to read the true temperature.

Mix **does not** improve with age. Old mix, or mix that has been stored at too high a temperature, can result in a finished product that is less than satisfactory from the appearance and taste standpoint. To retard bacteria growth in dairy based mixes, the best storage temperature range is between 36° to 40° F (2.2° to 4.4° C).

Some products tend to foam more than others. If excess foam should occur, skim off with a sanitized utensil and discard (Fig. 17). Periodically, stir the mix in the hopper with a sanitized utensil.

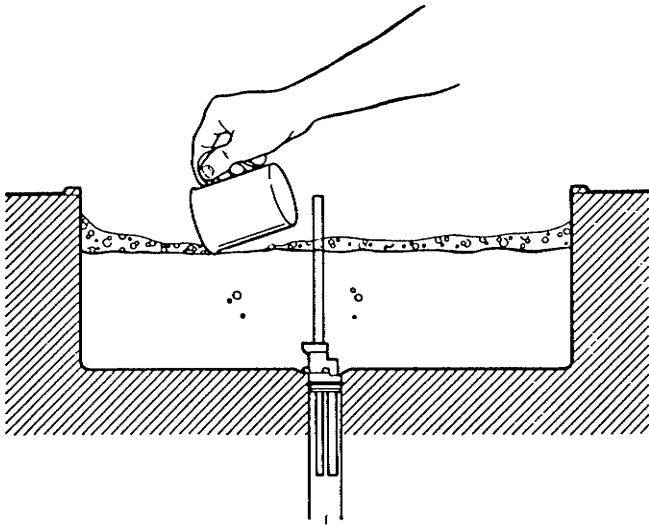

Figure 17. Skimming the Foam

3.6 REMOVING MIX FROM FREEZER

To remove the mix from the freezer, refer to the following steps:

- A. Remove the mix inlet regulator from the hopper by pulling straight up (Fig. 18).

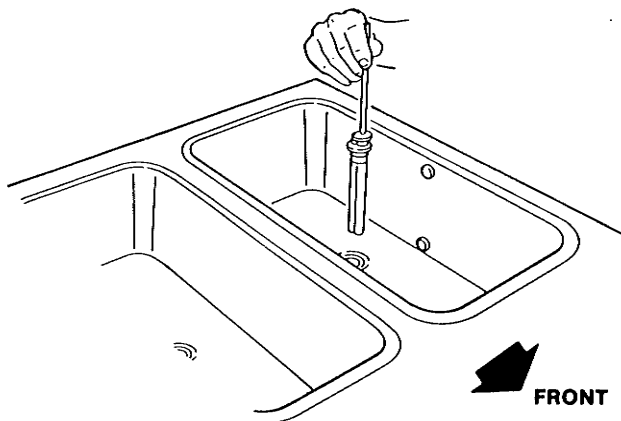

Figure 18. Removing Mix Inlet Regulator

- B. Place the CLEAN-OFF-ON rocker switch in the CLEAN position. Allow the mix to agitate in freezer barrel until the mix has become a liquid.

- C. Drain the liquid mix by opening the spigot. A bucket or container should be placed under the spigot to catch the liquid mix (Fig. 19).

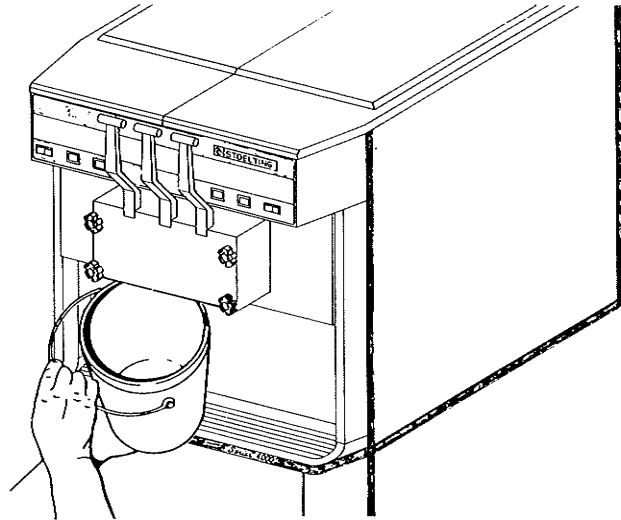

Figure 19. Draining Mix

- D. Place the CLEAN-OFF-ON switch in the OFF position.

3.7 CLEANING THE FREEZER

NOTE

The frequency of cleaning the freezer and freezer parts must comply with local health regulations.

The freezer is designed to be used with both barrels in operation. If you desire to use one barrel only, the freezer must be cleaned, sanitized and filled with fresh mix daily. For more information call your authorized Stoelting Serviceman.

After the mix has been removed from the freezer, the freezer must be cleaned. To clean the freezer, refer to the following steps:

- A. Close the spigot and fill the hoppers with 2 gallons (7.5 liters) of cold tap water.
- B. Place the CLEAN-OFF-ON switches in the CLEAN position.
- C. Allow the water to agitate for approximately five minutes.
- D. Open the spigots to drain the water. Remember to place a bucket or container under the spigots to catch the water. When the water has drained, turn the CLEAN-OFF-ON switches to the OFF position. Allow the freezer barrel to drain completely.
- E. Repeat steps A through D using a mild detergent solution.

3.8 DISASSEMBLY OF FREEZER PARTS

CAUTION

Place the clean-off-on rocker switches in the off position before disassembling for cleaning or servicing.

Inspection for worn or broken parts should be made at every disassembly of the freezer for cleaning or other purposes. All worn or broken parts should be replaced to ensure safety to both the operator and the customer and to maintain good freezer performance and a quality product. Two normal wear areas are the auger flights and front auger support (Fig. 20). Frequency of cleaning must comply with the local health regulations.

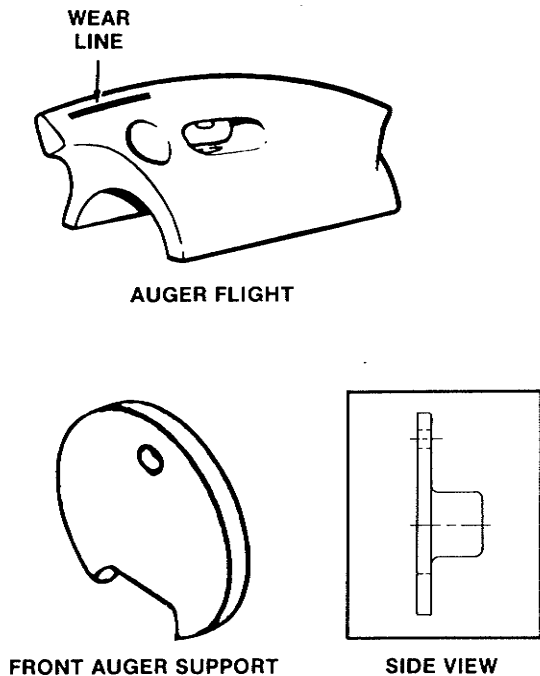

Figure 20. Auger Flight Wear and Front Auger Support Wear

To disassemble the freezer, refer to the following steps:

- A. Remove the mix inlet regulators from the hoppers by pulling straight up.
- B. Remove the front door by turning off the circular knobs and then pulling the front door off the studs (Fig. 21).

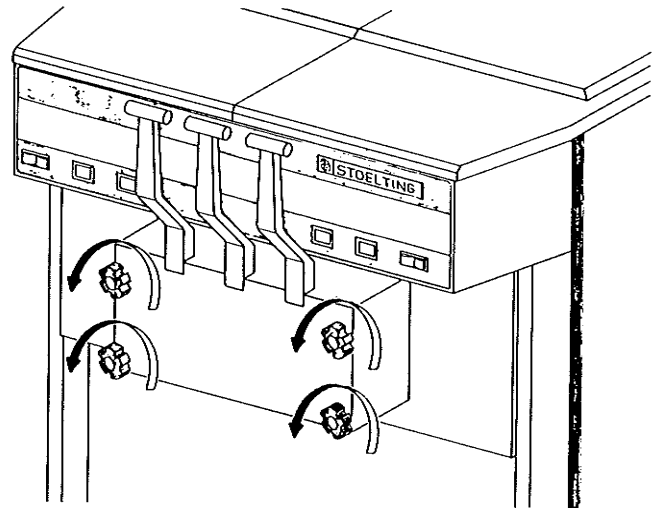

Figure 21. Removing Front Door

- C. Remove spigot extension adaptor or rosette. Pull the door handle pin out of the spigot handle. Push the spigot body through the bottom of the front door (Fig. 22). Remove the spigot body and spring.

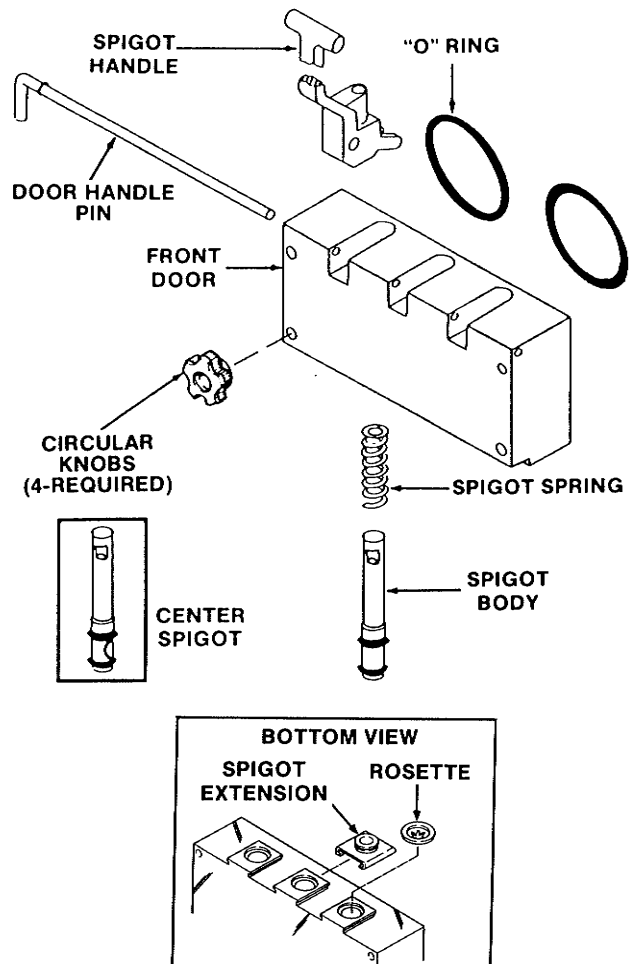

Figure 22. Removing Spigot

D. Remove the front auger supports (Fig. 23).

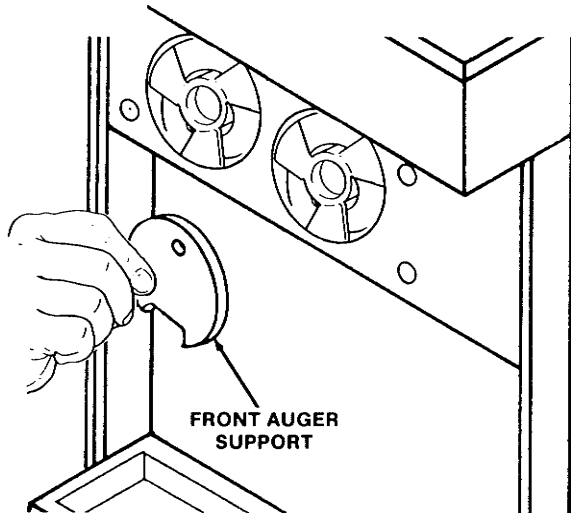

Figure 23. Removing Auger Supports

E. Remove the auger assemblies from the freezer. Pull the augers out of the freezer barrel slowly. As the augers are being pulled out, carefully remove each of the plastic flights with springs (Fig. 24).

F. Keep the rear of the auger shafts tipped up once they are clear of the freezer barrels to avoid dropping rear seals.

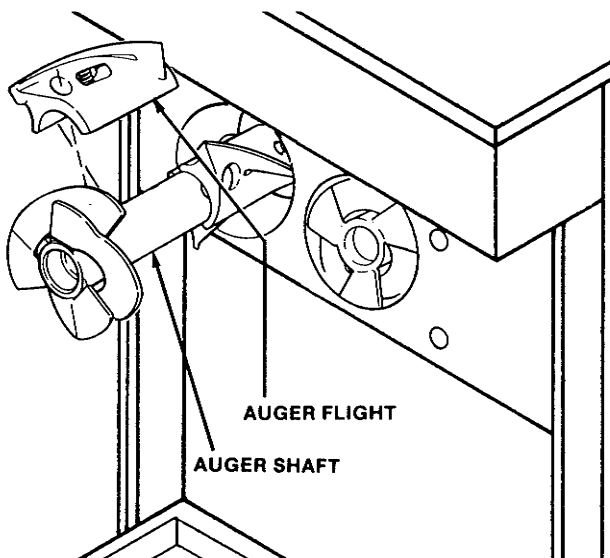

Figure 24. Auger Shafts

G. Remove the rear seals.

H. Wipe socket lubricant from the drive end (rear) of the auger with a cloth or paper towel.

I. Remove all "O" Rings from parts by first wiping off the lubricant using a clean paper towel. Then squeeze the "O" Ring upward with a dry cloth.

When a loop is formed, roll out of the "O" Ring groove (Fig. 25).

⚠ WARNING
DO NOT USE ANY TYPE OF SHARP OBJECT TO REMOVE THE "O" RINGS.

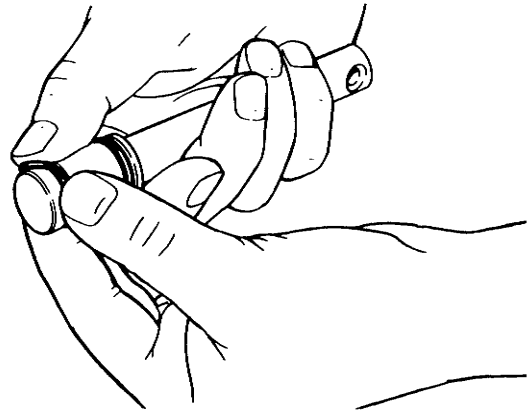

Figure 25. Removing "O" Ring

3.9 CLEANING THE FREEZER PARTS

Place all loose parts in a pan or container and take to the wash sink for cleaning. To clean freezer parts refer to the following steps:

A. Place all parts in warm mild detergent water and clean with brushes provided. Rinse all parts with clean hot water.

⚠ CAUTION

Do not damage parts by dropping or rough handling.

B. Wash the hopper and freezer barrel with warm detergent water and brushes provided (Fig. 26).

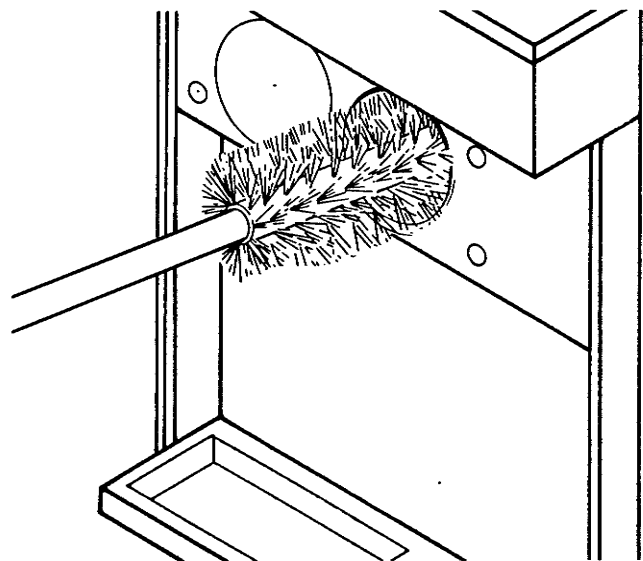

Figure 26. Cleaning Freezer Barrel

- C. Clean the drip tray and insert with a soap solution. Rinse with clean hot water.

3.10 SANITIZE FREEZER AND FREEZER PARTS

- A. Use a sanitizer mixed according to manufacturer's instructions to provide a 100 parts per million strength solution. Mix sanitizer in quantities of no less than 2 gallons (7.5 liters) of 120° F water. Allow the sanitizer to contact the surfaces to be sanitized for 5 minutes. Any sanitizer must be used only in accordance with the manufacturer's instructions.
- B. Place all parts in the sanitizing solution, then remove and let air dry.
- C. Using this sanitizing solution and the large barrel brush provided, sanitize the rear of the barrel and drive area by dipping the brush in the sanitizing solution and brushing the rear of the barrel.

3.11 ASSEMBLY OF FREEZER

To assemble the freezer parts, refer to the following steps:

NOTE

Petro-Gel sanitary lubricant or equivalent must be used when lubrication of parts is specified.

NOTE

The United States Department of Agriculture and the Food and Drug Administration require that lubricants used on food processing equipment be certified for this use. Use lubricants only in accordance with the manufacturer's instructions.

- A. Assemble all "O" Rings onto parts dry, **without lubrication**. Then apply a thin film of sanitary lubrication to exposed surfaces of the "O" Rings. Apply a thin film of sanitary lubricant to metal part of rear seal. Also apply a thin film of sanitary lubricant inside the hole on the front of the auger.
- B. Assemble the rear seals onto the augers with the large end to the rear. Be sure the "O" Ring is in place before installing the rear seal.
- C. Lubricate the inside of the auger drive sockets (rear) with a small amount of white socket

lubricant. A small container of socket lubricant is shipped with the freezer.

- D. Screw the springs onto the studs in plastic flights. **Springs must be screwed into the flights completely** to provide proper tension (Fig. 27).

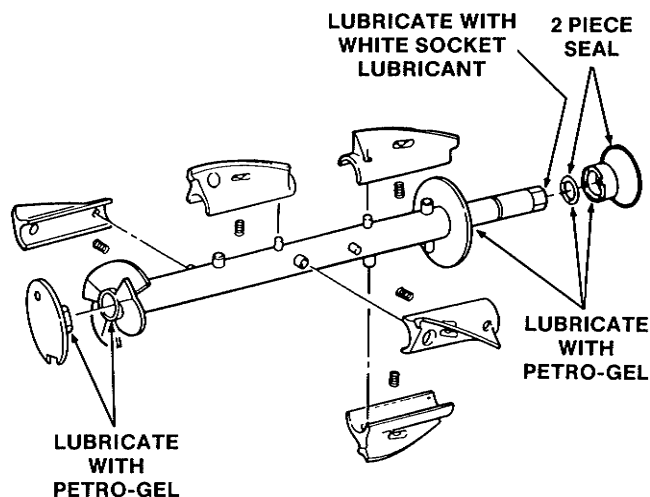

Figure 27. Exploded View of Auger

CAUTION

Do not place the mix inlet regulator into the hopper before installing the auger.

- E. Install the two plastic flights onto rear of the auger and insert part way into freezer barrel.
- F. Install the third plastic flight, push the auger into the freezer barrel and rotate slowly until the auger engages the drive shaft.
- G. Install the auger support into the front of the augers with the small hole of the support straight up.

NOTE

Apply a small amount of Petro-Gel to the surface of the cam on the spigot handle prior to assembly of handle to the spigot body.

- H. Install the spigot bodies with "O" Rings and spring into the front door from the bottom (Fig. 28). Push straight up until the spigots are in place. Place the spigot handle fork into the notches near the top of the spigot and insert door handle pin. Install spigot extension adaptor or rosette as desired.
- I. Install the front door on the freezer. Shoulder on the rear of the door must be inside of freezer barrel.

J. Install the circular knobs on the freezer studs.

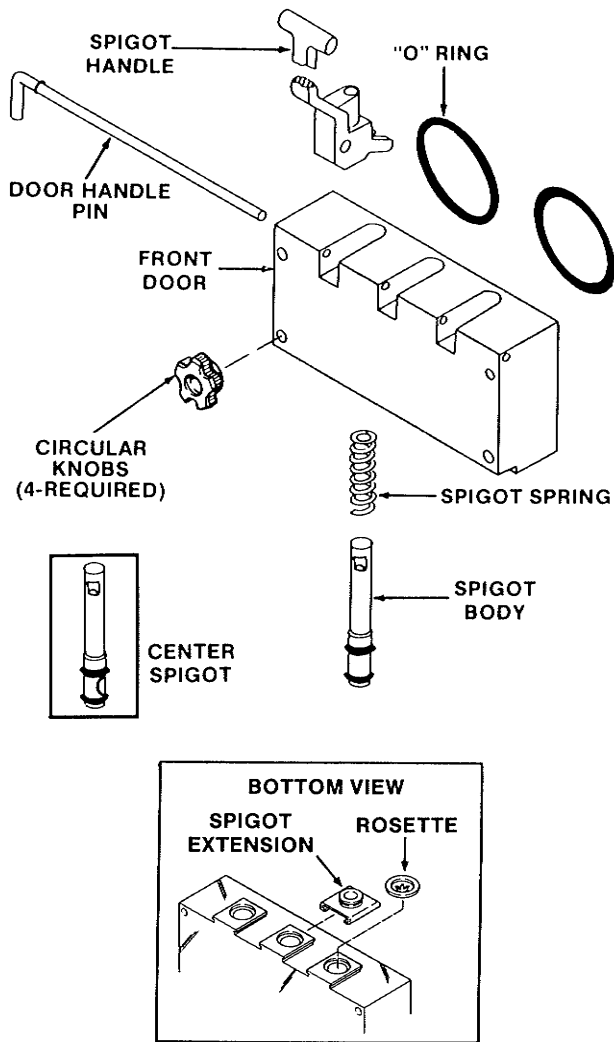

Figure 28. Exploded View of Front Door

⚠ CAUTION

Finger tighten the circular knobs evenly. Do not overtighten knobs.

Look for the proper seal between the freezer barrel, "O" Ring, and front doors.

K. Install the mix inlet regulators into the hopper with the air inlet (long) tube toward the front of the freezer (Fig. 29).

NOTE

Refer to page 10 paragraph 3.3 for sanitizing the assembled freezer before filling with mix.

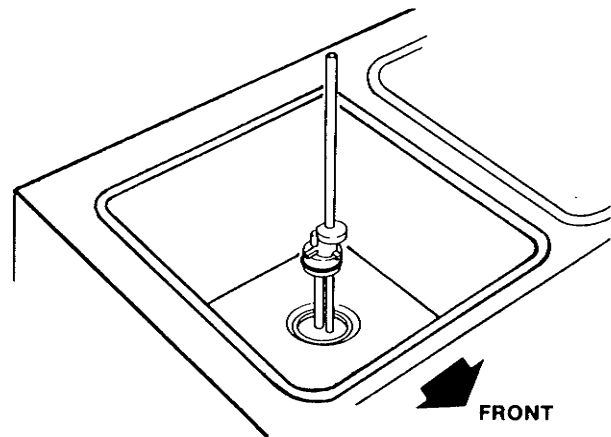

Figure 29. Installing Mix Inlet Regulators

3.12 ROUTINE CLEANING

To remove spilled or dried mix from the freezer exterior, simply wash in the direction of the finish with warm soapy water and wipe dry. **Do not** use highly abrasive materials as they will mar the finish.

SECTION 4 MAINTENANCE INSTRUCTIONS

4.1 PREVENTIVE MAINTENANCE

It is recommended that a preventive maintenance schedule be followed to keep the freezer clean and operating properly. The following steps are suggested as a preventive maintenance guide.



WARNING

NEVER ATTEMPT TO REPAIR OR PERFORM MAINTENANCE ON FREEZER UNTIL THE MAIN ELECTRICAL POWER HAS BEEN DISCONNECTED.

The United States Department of Agriculture and the Food and Drug Administration require that lubricants used on food processing equipment be certified for this use. Use lubricants only in accordance with the manufacturer's instructions.

A. DAILY

1. The exterior should be kept clean at all times to preserve the luster of the stainless steel. A mild alkaline cleanser is recommended. Use a soft cloth or sponge to apply the cleanser.
2. Using a sanitized one pint aluminum overrun container, skim the mix in the hopper to remove any foam buildup (Fig. 30).

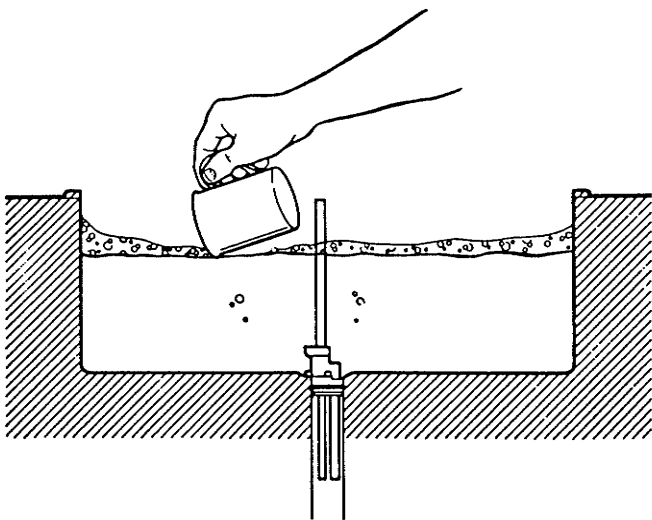

Figure 30. Skimming Hopper

3. Run a sanitized brush down mix inlet regulator (carburetor) tubes (Fig. 31).

NOTE

When sanitizing, the skimmer, brush and hand that holds the mix inlet regulator (carburetor) must also be sanitized.

4. Note any unusual noises or operating conditions upon startup. Repair or rectify immediately if problems exist.

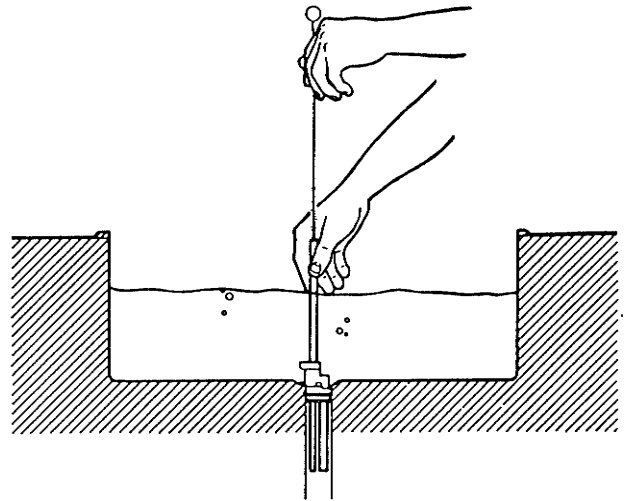

Figure 31. Sanitizing Mix Inlet Regulator (Carburetor)

NOTE

Do not use acid cleaners, strong caustic compounds or abrasive materials to clean any part of the freezer exterior or plastic parts.



CAUTION

Inspection for worn or broken parts should be made at each disassembly of the freezer.

B. WEEKLY

1. Check all "O" rings for excessive wear and replace if necessary.
2. Check scraper blades, front bearing and rear bearing for wear or damage (paragraph 3.8).

C. MONTHLY

1. Check drive belt for wear (paragraph 4.4).
2. Check condenser for dirt (paragraph 4.6).

4.2 FREEZE-UP

If a freeze-up does occur, use the following steps to thaw the mix in the freezer barrel:

CAUTION

If the drive belt squeals when the CLEAN-OFF-ON switch is placed in the ON position, or when the spigot is opened to dispense product, turn the CLEAN-OFF-ON switch to the OFF position.

- A. Check to make sure the spigot handle is closed completely, spigot switch is functioning properly, there is mix in the hopper, or the mix inlet regulator (carburetor) is not plugged.
- B. If drive motor overload was tripped, remove the middle front panel and push the reset button. If it will not reset wait 5 minutes and try again.
- C. Place the CLEAN-OFF-ON switch in the ON position and push the push to freeze switch.
- D. The product will be ready to serve when the green light illuminates.
- E. If the freezer continues to freeze-up, contact a qualified refrigeration service technician, local distributor, or Stoelting, Inc.

4.3 AIR FILTER AND CONDENSER SERVICE

- A. Remove either lower side panel and slide air filter out horizontally.
- B. Visually inspect the condenser for dirt by shining a light through the louvers.
- C. If the condenser is dirty, vacuum all loose dirt.
- D. If using compressed air or CO-2 tank to blow out the dirt, first place a wet towel over front of condenser.
- E. Blow out the dirt from the back of the condenser. Most of the dirt will cling to the wet towel.

CAUTION

This procedure emits a loud noise.

- F. An alternate method is to clean with a condenser brush and vacuum.

4.4 EXTENDED STORAGE

Refer to the following steps for winterizing the freezer for winter layup or any extended period of storage.

- A. Clean thoroughly with a **warm** mild detergent all parts that come in contact with mix. Rinse in clear water and dry all parts. Do **not** sanitize as prolonged exposure of metal parts to some sanitizers can cause corrosion.

NOTE

Do not let cleaning solution stand in freezer barrel or hopper during the shutdown period.

- B. Remove, disassemble, and clean the front door, auger and mix inlet regulator (carburetor). Leave disassembled during the shutdown period.
- C. Place plastic auger flights, rear bearing and front bearing in a plastic bag with a moist paper towel. This will prevent parts from becoming brittle if exposed to dry air over an extended period of time (over 30 days).

CAUTION

Barrel must be empty for following procedure.

- D. On water cooled freezers, shut off and disconnect water supply at rear of freezer; run compressor for 2 to 3 minutes to open water valve, and blow out all water first through inlet, then outlet line, using air or carbon dioxide.
- E. Disconnect the freezer from the electrical supply in the building.

4.5 TROUBLESHOOTING

WARNING

NEVER ATTEMPT TO REPAIR OR PERFORM MAINTENANCE ON FREEZER UNTIL THE MAIN ELECTRICAL POWER HAS BEEN DISCONNECTED.

Problem	Possible Cause	Remedy
Freezer does not run.	<ol style="list-style-type: none"> 1. Power to freezer is off. 2. Fuse or circuit breaker is blown or tripped. 3. Freeze-up 4. High pressure cut-out tripped. 	<ol style="list-style-type: none"> 1. Supply power to freezer. 2. Replace or reset. (If condition continues see notes 1 or 2.) 3. See paragraph 4.3. 4. Correct problem and reset.
Freezer shuts off on error.	<ol style="list-style-type: none"> 1. Low or no mix in hopper. 2. Low or no overrun. 3. Refrigeration problem. 	<ol style="list-style-type: none"> 1. Add mix. 2. Check mix inlet regulator. 3. Check system. (See note 1.)
Product is too soft	<ol style="list-style-type: none"> 1. No vent space for free flow of cooling air. 2. Air temperature entering condenser is above 100° F. (Air cooled.) 3. Condenser is dirty. (Air cooled.) 4. Consistency setting too soft. 5. Stabilizers in mix are broken down. 6. Refrigeration problem. 	<ol style="list-style-type: none"> 1. A minimum of 6 inches of vent space required. (See paragraph 2.2.) 2. Change location or direct hot air away from freezer. 3. Clean. (See paragraph 4.6.) 4. Readjust. (See paragraph 4.2.) 5. Remove mix, clean, sanitize and freeze down with fresh mix. 6. Check system. (See note 1.)
Product is too firm.	<ol style="list-style-type: none"> 1. Consistency setting too firm. 2. Spigot not fully closed. 	<ol style="list-style-type: none"> 1. Readjust. (See paragraph 4.2.) 2. Fully close spigot.
Product does not dispense.	<ol style="list-style-type: none"> 1. No mix in hopper. 2. Mix inlet regulator (carburetor) mix inlet tube is plugged. 3. Special mix inlet regulator (carburetor) needed for mix being used. 4. Capacity of freezer is being exceeded. 5. Drive motor overloaded. 6. Drive belt failure. 7. Freeze-up. 	<ol style="list-style-type: none"> 1. Fill hopper with mix. 2. Unplug, using small sanitized brush. 3. Order special mix inlet regulator (carburetor). (See note 2.) 4. Slow up on the draw rate. 5. Place reset lever in the ON position. (If condition continues see notes 1 or 2.) 6. See paragraph 4.4. 7. See paragraph 4.3.
Drive belt slipping or squealing	<ol style="list-style-type: none"> 1. Worn drive belt. 2. Freeze-up. 	<ol style="list-style-type: none"> 1. Replace drive belt. (See paragraph 4.4.) 2. See paragraph 4.3.
Low overrun	<ol style="list-style-type: none"> 1. Mix inlet regulator (carburetor) missing. 2. Mix inlet regulator (carburetor) "O" Ring missing. 3. Mix inlet regulator (carburetor) air tube blocked. 	<ol style="list-style-type: none"> 1. Replace mix inlet regulator (carburetor). 2. Replace mix inlet regulator (carburetor) "O" Ring. 3. Clean with sanitizer brush.
Front door leaks.	<ol style="list-style-type: none"> 1. Front door knobs are loose. 2. Spigot parts are not lubricated. 3. Chipped or worn spigot "O" Rings. 4. "O" Rings or spigot installed wrong. 5. Spigot hole in front door nicked or scratched. 	<ol style="list-style-type: none"> 1. Tighten knobs. 2. See paragraph 3.11. 3. Replace "O" Rings. 4. Remove spigot and check "O" Rings. 5. Replace front door.
Hopper will not maintain mix temperature below 45° F (7° C).	<ol style="list-style-type: none"> 1. EPR valve needs to be adjusted. 2. Temperature control failure. 3. Refrigeration problem. 	<ol style="list-style-type: none"> 1. (See note 1.) 2. Replace. (See notes 1 or 2.) 3. Check system. (See note 1.)
1. Must be performed by a qualified service person.		
2. The local dealer, distributor or Stoelting, Inc., Service Department should be contacted. Write or call: Stoelting, Inc., P.O. Box 127, Kiel, Wisconsin 53042; Phone (414) 894-2293; TWX #510-388-9511.		

SECTION 5 REPLACEMENT PARTS

5.1 HOW TO ORDER PARTS

To assure receipt of the proper replacement parts, supply your dealer or distributor with the following information:

- A. Model number of equipment.
- B. Serial number of model, stamped on nameplate.

- C. Part number, part name and quantity needed. Common part names and numbers are listed in this manual.

Part Number	Ref. No.	Description
324014		Decal Black Arrow
324141		Decal Caution
324175		Decal Cleaning
324234		Decal Ventilation
324346		Decal Caution
H324416		Decal - Drip Tray
H324415		Decal - Header Panel

5.2 PUSH FREEZE LIGHT/SWITCH LAMP REPLACEMENT

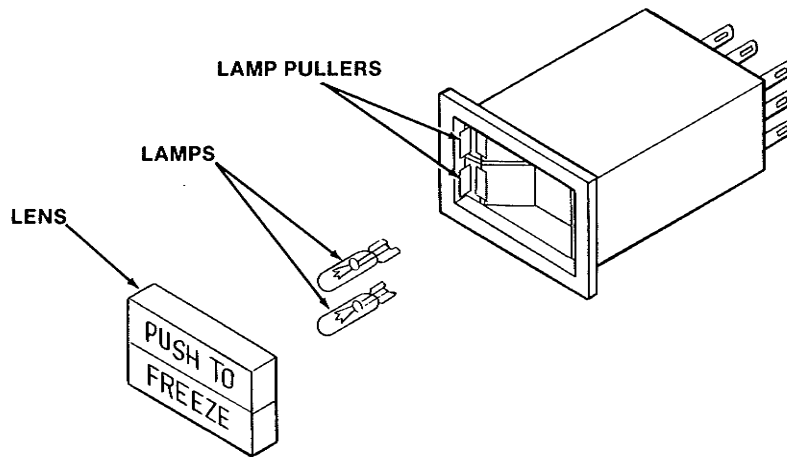
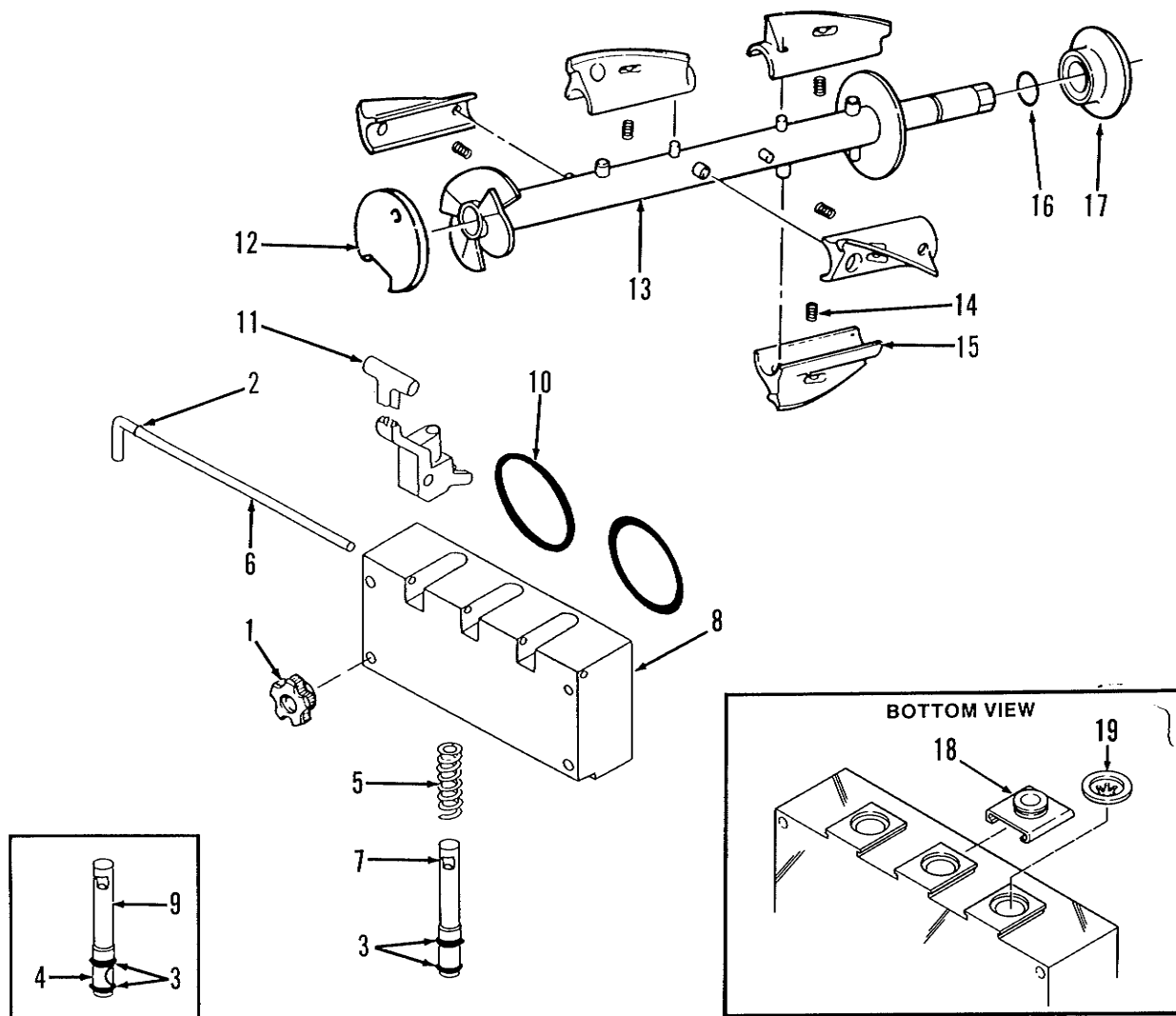

Figure 32. Push To Freeze Light/Switch Assembly

To change a lamp in the PUSH TO FREEZE switch/light follow these simple steps.

- A. Grasp the lens with your thumb and forefinger and pull out.
- B. Remove the faulty lamp by pulling out the lamp puller. (See Fig. 32.)
- C. To install the new lamp, line up the lamp end with the receptical and push fully in.
- D. Reinstall the lens by pushing firmly in. When installed "PUSH TO" must be right side up.



5.3 SPIGOT, FRONT DOOR AND AUGER ASSEMBLY

Part Number	Ref. No.	Description	Qty.
482019	1	Knob Block	4
624515	2	"O" Ring Door Handle Pin	1
624618	3	"O" Ring Spigot Body	6
624666	4	"O" Ring Center Spigot	1
694333	5	Spring Spigot	3
1144409	6	Pin Door Handle	1
2142539	7	Spigot Body	3
2145083	8	Front Door	1
2146234	9	Center Spigot	1
625134	10	"O" Ring Front Door	2
2143793	11	Spigot Handle Assembly	3
2144363	12	Front Auger Support	1
3147904	13	Auger Shaft	1
694255	14	Spring	5
381804	15	Auger Flight	5
624678	16	"O" Ring Shaft Seal	1
666786	17	Rear Auger Seal	1
521150	18	Spigot Extension Adaptor	1
232732	19	Rosette	1

Figure 33. Spigot, Front Door and Auger Assembly