



**Model CC-A Series**  
**SERVICE MANUAL**

Manual No. [513692](#)

Rev.0



This manual provides basic information about the machine. Instructions and suggestions are given covering its operation and care.

The illustrations and specifications are not binding in detail. We reserve the right to make changes to the machine without notice, and without incurring any obligation to modify or provide new parts for machines built prior to date of change.

**DO NOT ATTEMPT** to operate the machine until instructions and safety precautions in this manual are read completely and are thoroughly understood. If problems develop or questions arise in connection with installation, operation, or servicing of the machine, contact Stoelting.



[stoeltingfoodservice.com](http://stoeltingfoodservice.com)

Stoelting Foodservice Equipment  
502 Highway 67  
Kiel, WI 53042-1600  
U.S.A.

Main Tel: 800.558.5807  
Fax: 920.894.7029

Customer Service: 888.429.5920  
Fax: 800.545.0662  
Email: [foodservice@stoelting.com](mailto:foodservice@stoelting.com)

© 2014 PW Stoelting, LLC

---

## ***A Few Words About Safety***

### **Safety Information**

**Read and understand the entire manual before operating or maintaining Stoelting equipment.**

This manual provides the operator with information for the safe operation and maintenance of Stoelting equipment. As with any machine, there are hazards associated with their operation. For this reason safety is emphasized throughout the manual. To highlight specific safety information, the following safety definitions are provided to assist the reader.

The purpose of safety symbols is to attract your attention to possible dangers. The safety symbols, and their explanations, deserve your careful attention and understanding. The safety warnings do not by themselves eliminate any danger. The instructions or warnings they give are not substitutes for proper accident prevention measures.

If you need to replace a part, use genuine Stoelting parts with the correct part number or an equivalent part. We strongly recommend that you do not use replacement parts of inferior quality.



### **Safety Alert Symbol:**

**This symbol** Indicates danger, warning or caution. Attention is required in order to avoid serious personal injury. The message that follows the symbol contains important information about safety.

### **Signal Word:**

Signal words are distinctive words used throughout this manual that alert the reader to the existence and relative degree of a hazard.



The signal word "WARNING" indicates a potentially hazardous situation, which, if not avoided, may result in death or serious injury and equipment/property damage.



The signal word "CAUTION" indicates a potentially hazardous situation, which, if not avoided, may result in minor or moderate injury and equipment/property damage.

### **CAUTION**

The signal word "CAUTION" not preceded by the safety alert symbol indicates a potentially hazardous situation, which, if not avoided, may result in equipment/property damage.

### **NOTE (or NOTICE)**

The signal word "NOTICE" indicates information or procedures that relate directly or indirectly to the safety of personnel or equipment/property.

# TABLE OF CONTENTS

Section	Description	Page
<b>1</b>	<b>Description and Specifications</b>	
1.1	Description.....	1
1.2	Dimensions.....	1
1.3	Specifications .....	3
1.4	International Electrical Specifications .....	6
<b>2</b>	<b>Maintenance and Adjustments</b>	
2.1	Machine Adjustment .....	7
2.2	Obtaining Readings and Modifying Settings (Service Personnel Only).....	7
2.3	Readings (Service Personnel Only) .....	7
2.4	Settings (Service Personnel Only).....	7
2.5	Drive Belt Tension Adjustment.....	8
2.6	Preventative Maintenance .....	9
2.7	Extended Storage.....	10
<b>3</b>	<b>Error Codes and Troubleshooting</b>	
3.1	Error Codes .....	11
3.2	Troubleshooting Error Codes.....	11
3.3	Troubleshooting Machine .....	13
<b>4</b>	<b>Refrigeration &amp; Wiring Diagrams</b>	
4.1	Refrigeration Diagrams.....	15
4.2	Wiring Diagrams .....	16
<b>5</b>	<b>Replacement Parts</b>	
5.1	Brushes, Decals and Miscellaneous.....	31
5.2	Auger Shaft and Faceplate Parts .....	32
5.3	Hopper Parts .....	33
5.4	Panels and Screws.....	34
5.5	Faucet.....	34
5.6	Electrical Panels .....	35
5.7	Right Side View .....	36
5.8	Rear View .....	37
5.9	Left Side View.....	38
5.10	Dipping Troughs .....	39



# SECTION 1 DESCRIPTION AND SPECIFICATIONS

## 1.1 DESCRIPTION

The CC series machines are continuous flow custard machines. They are equipped with fully automatic controls to provide a uniform product and feature Quick-Freeze technology. This manual is designed to assist qualified service personnel and operators in the installation, operation and maintenance of the CC series frozen custard machines.

### NOTE

*Product breakdown could happen quicker if product is stored in the freezing cylinders for more than one hour. After a batch is made, close the flow control and empty the contents of the freezing cylinder.*

The information in this booklet is to be used for reference of technical specifications only. It is intended for qualified service technicians. Never attempt to operate or service equipment without first thoroughly reading and understanding the appropriate Owner's and Service Manuals.



**Figure 1-1 Model CC303**

## 1.2 DIMENSIONS

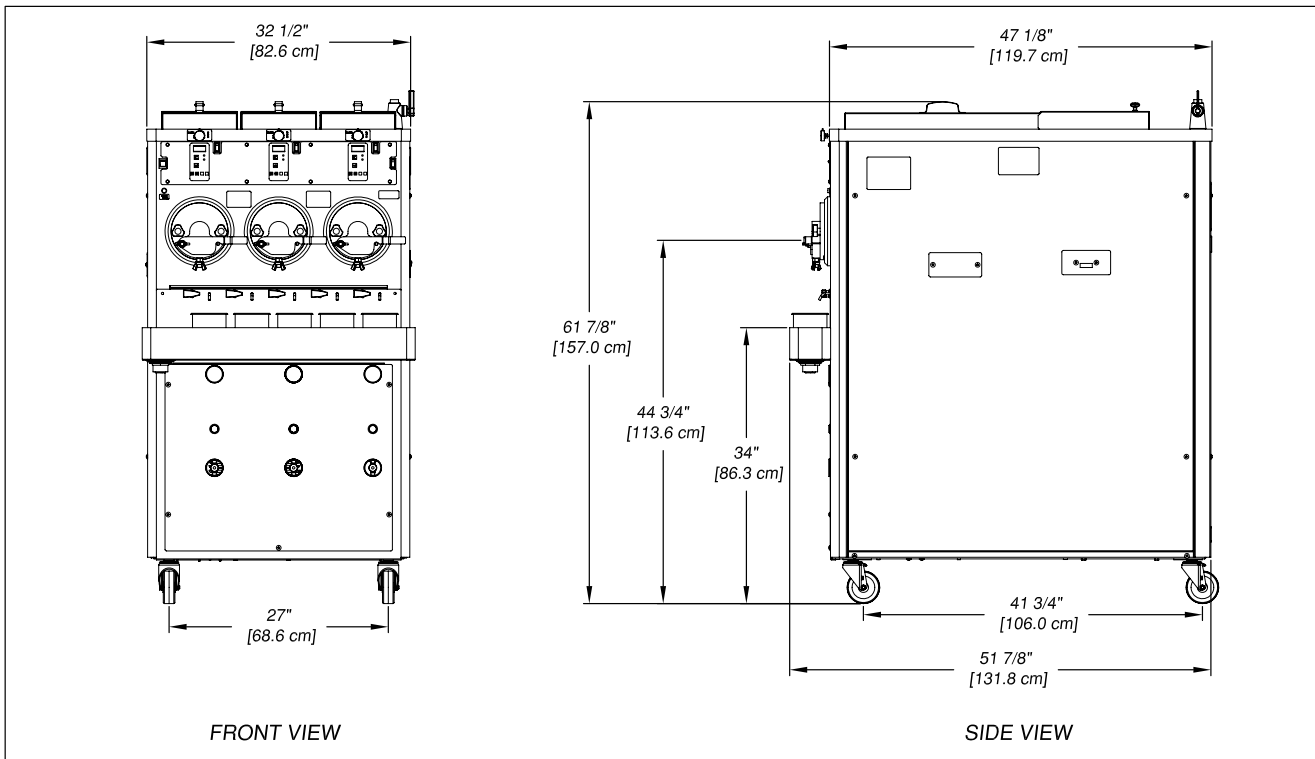

**Figure 1-2 Model CC303 Dimensions**

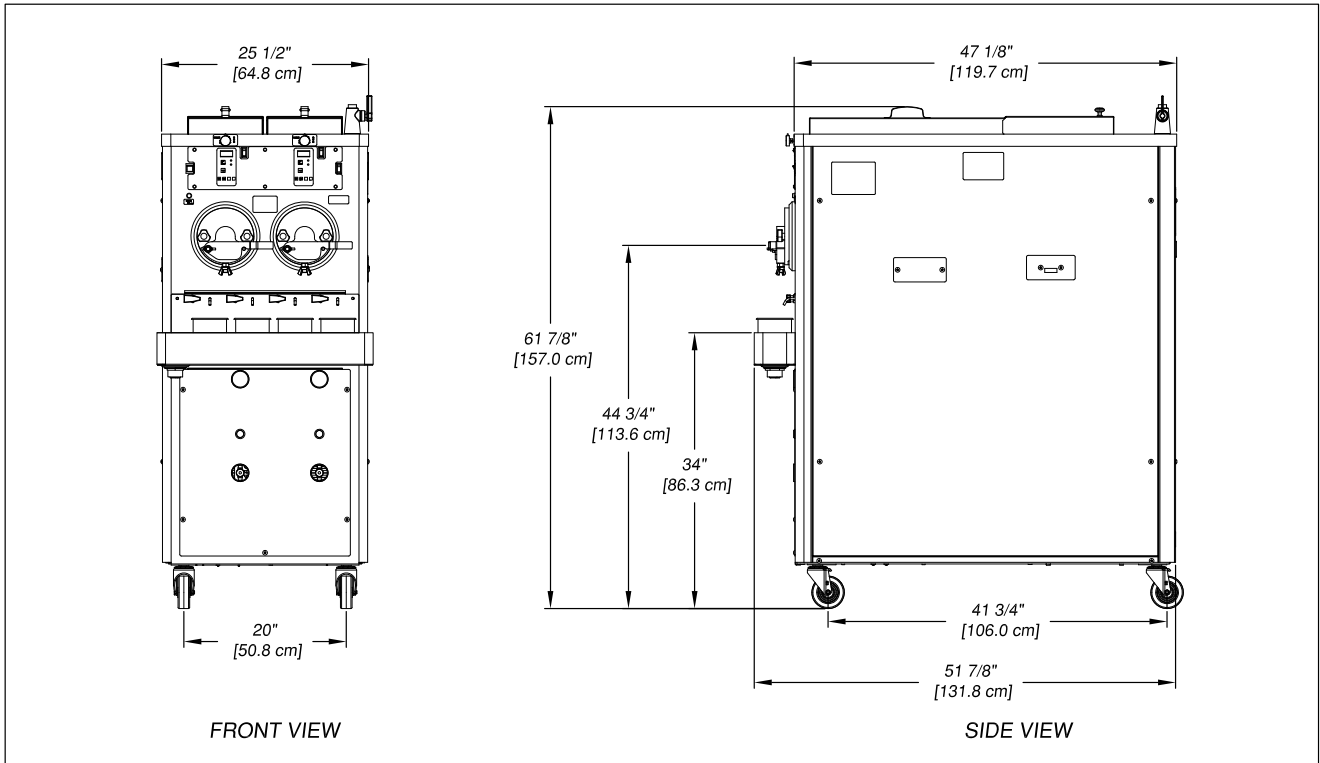

Figure 1-4 Model CC202 Dimensions

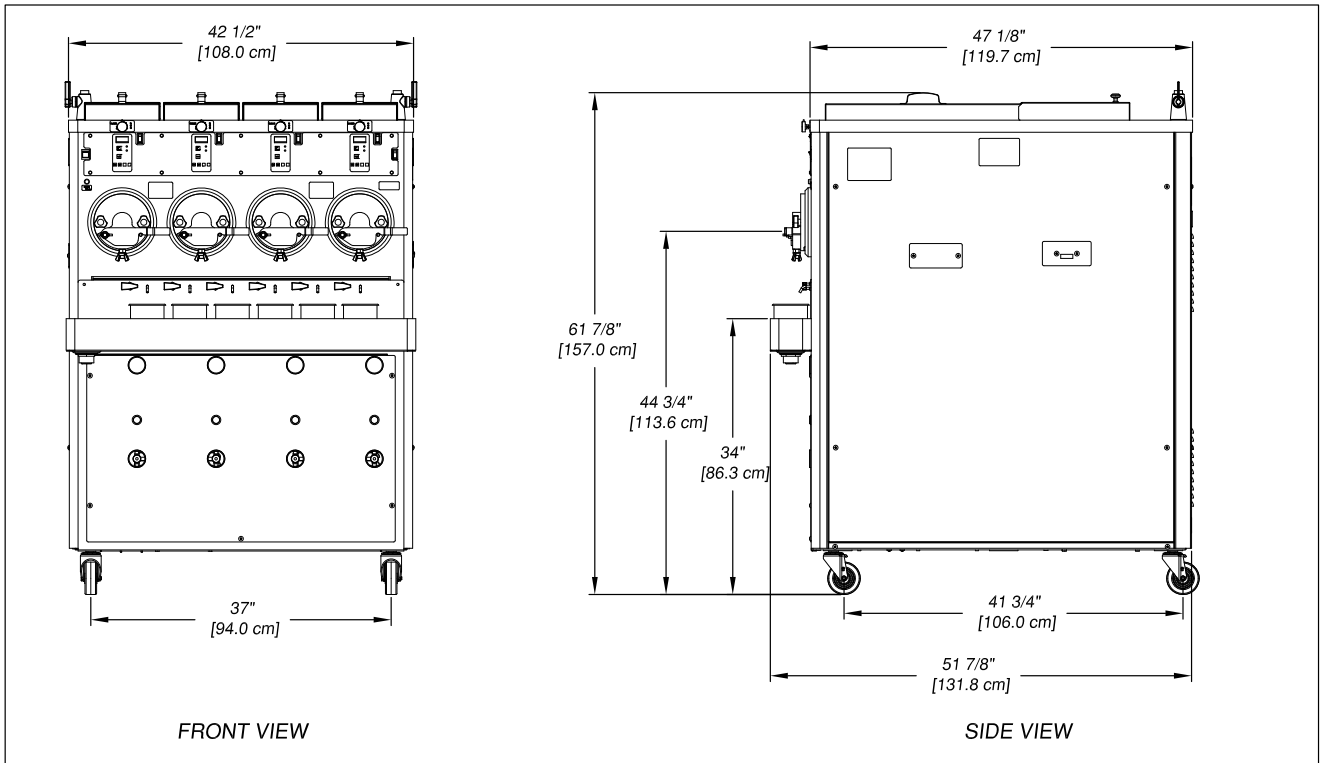

Figure 1-5 Model CC404 Dimensions

### 1.3 SPECIFICATIONS

	<b>CC303A Air Cooled Remote</b>		<b>CC303A Water Cooled</b>	
<b>Dimensions</b>	<b>Machine</b>	<b>with crate</b>	<b>Machine</b>	<b>with crate</b>
width	32-1/2" (82,6 cm)	44-1/2" (113,0 cm)	32-1/2" (82,6 cm)	44-1/2" (113,0 cm)
height	61-7/8" (157,2 cm)	67" (170,2 cm)	61-7/8" (157,2 cm)	67" (170,2 cm)
depth	47-1/8" (119,7 cm)	60" (152,4 cm)	47-1/8" (119,7 cm)	60" (152,4 cm)
<b>Weight</b>	895 lbs (405,9 kg)	970 lbs (439,9 kg)	1345 lbs (610,0 kg)	1420 lbs (644,1 kg)
<b>Electrical</b>	<b>1 Phase, 208-240 VAC, 60Hz</b>	<b>3 Phase, 208-240 VAC, 60Hz</b>	<b>1 Phase, 208-240 VAC, 60Hz</b>	<b>3 Phase, 208-240 VAC, 60Hz</b>
circuit ampacity (per barrel)	12A minimum	9A minimum	29A minimum	19A minimum
overcurrent protection device (per barrel)	25A maximum	15A maximum	50A maximum	30A maximum
<b>Hopper Condensing Unit</b>	<b>1 Phase, 115 VAC, 60Hz</b> NEMA5-15P power cord provided			
<b>Drive Motor</b>	Three - 3 hp			
<b>Cooling</b>	Air cooled units require one remote condensing unit (with compressor) per barrel. The condensing units ship from the factory with 20 lbs of R-404A for up to a 50' line set. Add 1 lb of refrigerant for every 10' increase to the line set. Line set max 100'.		Water cooled units are self contained and require a Standard Hose Adapter water fitting and a 1/2" OD drain fitting for each barrel. They are charged with R-404A. Maximum water pressure of 130 psi Minimum water flow rate of 3 GPM Ideal EWT of 60°-80°F	
<b>Hopper Volume</b>	Three - 8.8 gallon (33,32 liters)			

	<b>CC303*</b>
<b>Refrigerant</b>	R-404A
<b>Charge</b>	(W/C) 10 lbs (A/C) 24 lbs
<b>AXV</b>	28-32 psig
<b>Head Pressure Regulator (Water Valve)</b>	(W/C) 225-235 psig (A/C) 255 psig
<b>Crankcase Pressure Regulator</b>	25 psig
<b>Lemon Ice AXV</b>	38-42 psig
	<b>Hopper</b>
<b>Hopper Refrigerant</b>	R-134A
<b>Hopper Charge</b>	1 lb 3 oz
<b>Suction Pressure</b>	13-17 psig

\* There is a separate refrigeration system for each freezing cylinder and a separate refrigeration system for hopper cooling. The refrigeration specifications are per freezing cylinder.

Maximum nitrogen pressure of 240 psig when leak testing.

	<b>CC202A Air Cooled Remote</b>		<b>CC202A Water Cooled</b>	
<b>Dimensions</b>	<b>Machine</b>	<b>with crate</b>	<b>Machine</b>	<b>with crate</b>
width	25-1/2" (64,8 cm)	44-1/2" (113,0 cm)	25-1/2" (64,8 cm)	44-1/2" (113,0 cm)
height	61-7/8" (157,2 cm)	67" (170,2 cm)	61-7/8" (157,2 cm)	67" (170,2 cm)
depth	47-1/8" (119,7 cm)	60" (152,4 cm)	47-1/8" (119,7 cm)	60" (152,4 cm)
<b>Weight</b>	632 lbs (286,6 kg)	707 lbs (320,6 kg)	930 lbs (421,8 kg)	1005 lbs (455,8 kg)
<b>Electrical</b>	<b>1 Phase, 208-240 VAC, 60Hz</b>	<b>3 Phase, 208-240 VAC, 60Hz</b>	<b>1 Phase, 208-240 VAC, 60Hz</b>	<b>3 Phase, 208-240 VAC, 60Hz</b>
circuit ampacity (per barrel)	12A minimum	9A minimum	29A minimum	19A minimum
overcurrent protection device (per barrel)	25A maximum	15A maximum	50A maximum	30A maximum
<b>Hopper Condensing Unit</b>	<b>1 Phase, 115 VAC, 60Hz</b> NEMA5-15P power cord provided			
<b>Drive Motor</b>	Two - 3 hp			
<b>Cooling</b>	Air cooled units require one remote condensing unit (with compressor) per barrel. The condensing units ship from the factory with 20 lbs of R-404A for up to a 50' line set. Add 1 lb of refrigerant for every 10' increase to the line set. Line set max 100'.		Water cooled units are self contained and require a Standard Hose Adapter water fitting and a 1/2" OD drain fitting for each barrel. They are charged with R-404A. Maximum water pressure of 130 psi Minimum water flow rate of 3 GPM Ideal EWT of 60°-80°F	
<b>Hopper Volume</b>	Two - 8.8 gallon (33,32 liters)			

	<b>CC202*</b>
<b>Refrigerant</b>	R-404A
<b>Charge</b>	(W/C) 10 lbs (A/C) 24 lbs
<b>AXV</b>	28-32 psig
<b>Head Pressure Regulator (Water Valve)</b>	(W/C) 225-235 psig (A/C) 255 psig
<b>Crankcase Pressure Regulator</b>	25 psig
<b>Lemon Ice AXV</b>	38-42 psig
	<b>Hopper</b>
<b>Hopper Refrigerant</b>	R-134A
<b>Hopper Charge</b>	1 lb 2 oz
<b>Suction Pressure</b>	13-17 psig

\* There is a separate refrigeration system for each freezing cylinder and a separate refrigeration system for hopper cooling. The refrigeration specifications are per freezing cylinder.

Maximum nitrogen pressure of 240 psig when leak testing.

<b>CC404A</b>		
<b>Dimensions</b>	<b>Machine</b>	<b>with crate</b>
width	42-1/2" (108,0 cm)	50" (127,0 cm)
height	61-7/8" (157,2 cm)	67" (170,2 cm)
depth	47-1/8" (119,7 cm)	60" (152,4 cm)
<b>Weight</b>	1135 lbs (514,8 kg)	1210 lbs (548,8 kg)
<b>Electrical</b>	<b>3 Phase, 208-240 VAC, 60Hz</b>	
circuit ampacity (per barrel)	9A minimum	
overcurrent protection device (per barrel)	15A maximum	
<b>Hopper Condensing Unit</b>	<b>1 Phase, 115 VAC, 60Hz</b>	
	NEMA5-15P power cord provided	
<b>Drive Motor</b>	Four - 3 hp	
<b>Cooling</b>	Air cooled units require one remote condensing unit (with compressor) per barrel. The condensing units ship from the factory with 20 lbs of R-404A for up to a 50' line set. Add 1 lb of refrigerant for every 10' increase to the line set. Line set max 100'.	Water cooled units are self contained and require a Standard Hose Adapter water fitting and a 1/2" OD drain fitting for each barrel. They are charged with R-404A. Maximum water pressure of 130 psi Minimum water flow rate of 3 GPM Ideal EWT of 60°-80°F
<b>Hopper Volume</b>	Four - 8.8 gallon (33,32 liters)	

<b>CC404*</b>	
<b>Refrigerant</b>	R-404A
<b>Charge</b>	24 lbs
<b>AXV</b>	28-32 psig
<b>Head Pressure Regulator (Water Valve)</b>	255 psig
<b>Crankcase Pressure Regulator</b>	25 psig
<b>Lemon Ice AXV</b>	38-42 psig
	<b>Hopper</b>
<b>Hopper Refrigerant</b>	R-134A
<b>Hopper Charge</b>	1 lb 4 oz
<b>Suction Pressure</b>	13-17 psig

\* There is a separate refrigeration system for each freezing cylinder and a separate refrigeration system for hopper cooling. The refrigeration specifications are per freezing cylinder.

Maximum nitrogen pressure of 240 psig when leak testing.

<b>CC Remote Condensing Unit (1 per barrel)</b>	
<b>Dimensions</b>	<b>Condenser</b>
width	37-3/4" (95,9 cm)
height	17-1/4" (43,7 cm)
depth	28-1/4" (71,7 cm)
<b>Weight</b>	222 lbs (100,7 kg)
<b>Electrical</b>	<b>1 Phase, 208-230 VAC, 60Hz</b> <b>3 Phase, 208-230 VAC, 60Hz</b>
circuit ampacity	20A minimum      15A minimum
overcurrent protection device	25A maximum      20A maximum
<b>Refrigerant</b>	R-404A

<b>Menu</b>	<b>Display</b>	<b>Value</b>
<b>Product 1</b>	Cut In T	30 °F
	Cut Out T	-20 °F
<b>Product 2</b>	Cut In T	30 °F
	Cut Out T	-20 °F
<b>Standby</b>	Cut In T	45 °F
	Cut Out T	40 °F
	On Time	60 seconds
	Off Time	900 seconds
	Stir On	5 seconds
	Stir Off	15 minutes
<b>Storage</b>	HprCutIn	39 °F
	HprCtOut	38 °F
	Hpr On	100 seconds
	Hpr Off	6 minutes

#### 1.4 INTERNATIONAL ELECTRICAL SPECIFICATIONS

The table below shows the electrical requirements per barrel. Refer to the tables in Section 1.2 for the remainder of the specifications. There is a separate electrical circuit for each barrel.

	<b>Air Cooled Remote</b>		<b>Water Cooled</b>	
<b>Electrical</b>	<b>1 Phase, 200-220 VAC, 50Hz</b>	<b>3 Phase, 380-415* VAC, 50Hz</b>	<b>1 Phase, 200-220 VAC, 50Hz</b>	<b>3 Phase, 380-415* VAC, 50Hz</b>
circuit ampacity (per barrel)	12A minimum	6A minimum	32A minimum	12A minimum
overcurrent protection device (per barrel)	25A maximum	10A maximum	50A maximum	20A maximum
<b>Hopper Condensing Unit</b>	<b>1 Phase, 200-240 VAC, 50Hz</b> Requires a 15amp power cord			
<b>Drive Motor</b>	Three - 2 hp			

\* The 380-415 VAC supply requires a neutral. The power supply must be 5 wire for proper operation.

<b>Remote Condensing Unit (1 per barrel)</b>		
<b>Electrical</b>	<b>1 Phase, 200-220 VAC, 50Hz</b>	<b>3 Phase, 380-415 VAC, 50Hz</b>
circuit ampacity	20A minimum	15A minimum
overcurrent protection device	25A maximum	20A maximum

## SECTION 2 MAINTENANCE AND ADJUSTMENTS

### 2.1 MACHINE ADJUSTMENT

This section is intended to provide maintenance personnel with a general understanding of the machine adjustments. It is recommended that any adjustments in this section be made by a qualified person.

### 2.2 OBTAINING READINGS AND MODIFYING SETTINGS (SERVICE PERSONNEL ONLY)

Readings and Settings on the IntelliTec control are accessed through the IntelliTec control menu settings. Locating the readings and settings are done using the up arrow (↑) and left arrow (←) buttons on the membrane switch. A printed IntelliTec Menu Settings sheet is located in the information pouch behind the header panel.

#### IntelliTec Control Readings

To obtain machine readings, locate the value on the machine's menu settings sheet and follow the steps below.

- A. Press and hold the SEL button for 8 seconds. While still holding the SEL button, press the up arrow button (↑). The LCD screen will read DISPLAY.
- B. Release both buttons.
- C. Press the up arrow button (↑) to navigate to the correct reading under DISPLAY or press the left arrow (←) button to navigate to the ERRCODES menu.
- D. Press the up arrow (↑) and left arrow (←) buttons to navigate through the rest of the readings as needed.
- E. When all readings have been obtained, press SEL button until the ExitMenu screen is displayed. Then press the up arrow button (↑) to return to the current mode display.

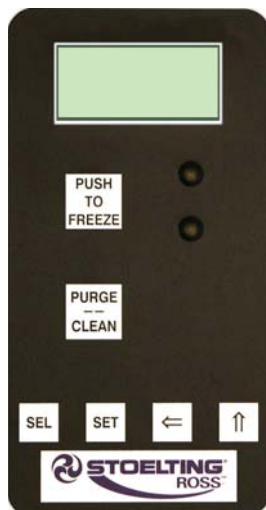

Figure 2-1 Membrane Switch

#### Modifying Control Settings

To change the value of a setting, locate it on the IntelliTec Menu Settings sheet and follow the steps below.

#### IMPORTANT:

*Before making changes to any settings, record the original values. If the setting changes do not achieve desired results, return settings to their original values.*

- A. Press and hold the SEL button for 8 seconds. While still holding the SEL button, press the up arrow button (↑). The LCD Screen will read DISPLAY.
- B. Release both buttons.
- C. Press the left arrow button (←) to get to the correct menu (Product1, Product 2, Stand By, Storage).
- D. Press the up arrow button (↑) to navigate to the value that needs to be changed.
- E. Press the SET button to enter the edit mode.
- F. Press the up arrow button (↑) to change the setting.
- G. Press the SET button to save the setting and exit the edit mode.
- H. Press the up arrow (↑) and the left arrow (←) buttons to navigate through the rest of the settings as needed.
- I. When all changes have been completed, press the up arrow button (↑) from ExitMenu to return to the current mode display.

### 2.3 READINGS (SERVICE PERSONNEL ONLY)

The IntelliTec control continuously monitors and records temperatures, voltages, amps, and error code details. Each reading is beneficial to service personnel when troubleshooting.

#### DISPLAY READINGS

Following are the readings available under the DISPLAY menu:

##### Hopper

The temperature of the hopper is constantly monitored by the IntelliTec control.

##### °F and amps

Suction line temperature on the freezing cylinder and drive motor amps are available on the same screen to assist with setup and troubleshooting.

**Aux. Temp (°F)**

This reading provides the ambient temperature around the IntelliTec control board.

**Supply V (VAC)**

The input voltage is recorded.

**ERROR CODE READINGS**

The following details are recorded under the ERRCODES menu for each of the last 25 error codes received:

**Err1 (hours)**

A timer begins when an error occurs. The timer records the number of hours since the error occurred. If power to the machine is interrupted, the timer will stop until power has been restored.

**°F and amps**

The suction gas temperature on the freezing cylinder and the drive motor amps are recorded at the time of the error.

**Aux. Temp (°F)**

Ambient temperature of the IntelliTec control board is recorded at the time of the error.

**Str (°F)**

The storage temperature is recorded at the time of the error.

**VAC and Mode**

The input voltage and mode at which the error occurred are recorded. See the table below for descriptions of each mode (Fig. 4-2).

**Up Time (hours)**

This value is a record of the total time the machine has been in service. If power is interrupted, the timer will stop until power is restored. This timer does not reset.

**2.4 SETTINGS (SERVICE PERSONNEL ONLY)**

Changing any setting on the IntelliTec control will alter machine operation and affect the product temperature, consistency, or life. Refer to the IntelliTec Menu Settings sheet located in the information pouch behind the header panel of the machine. If any of the following settings on the IntelliTec control differ from the settings sheet, it is recommended to return those settings to factory defaults.

**PRODUCT1 AND PRODUCT2 MENUS:****Cut In T (°F)**

This setting determines when refrigeration will start during Run Mode.

**Cut Out T (°F)**

This setting determines when refrigeration stops during Run Mode.

**Product 1 / Product 2**

This text is shown on the top line after the Push To Freeze button is pressed. The default value is "CUSTARD" for Product 1 and "PRODUCT2" for Product 2.

**On Time (sec)**

In case of a temperature sensor failure, this setting determines the length of a refrigeration cycle.

Code	Description	Compressor	Drive Motor	Details
1	Start-Up	Off	Off	
2	Standby	Off	Off	Waiting for a Cycle
3	Standby	Off	Off	
4	Standby	On	Off	
5	Standby	Off	Off	Sensor Fail
6	Standby	On	Off	Sensor Fail
7	Freeze Down	On	Off	Product 1
8	Run Mode	On	On	Product 1
9	Run Mode	Off	On	Product 1
10	Freeze Down	On	Off	Product 2
11	Run Mode	On	On	Product 2
12	Run Mode	Off	On	Product 2
13	Sensor Fail	On	On	Product 1
14	Sensor Fail	On	On	Product 2
15	Sensor Fail	Off	On	Product 2
16	Purge Mode	Hopper Only	On	
17	Clean Mode	Off	Off	
18	High Pressure Cutout	Off	Off	
19	Door Safety Switch Triggered	Off	Off	

**Figure 2-2 Modes When Error Occurs**

**Off Time (sec)**

In case of a temperature sensor failure, this setting determines the amount of time between refrigeration cycles.

**STAND BY MENU:****Cut In T (°F)**

This setting determines when refrigeration will start during Stand By Mode.

**Cut Out T (°F)**

This setting determines when refrigeration stops during Stand By Mode.

**On Time (sec)**

In case of a temperature sensor failure, this setting determines the length of a refrigeration cycle.

**Off Time (sec)**

In case of a temperature sensor failure, this setting determines the amount of time between refrigeration cycles.

**STORAGE MENU:****Refriger**

This setting changes how the control handles the storage refrigeration cycle. The setting is Hopper and should not be changed.

**HprCutIn (°F)**

This setting determines the temperature at which the hopper refrigeration cycle starts.

**HprCtOut (°F)**

This setting determines the temperature at which the hopper refrigeration cycle stops.

**Hpr On**

In case of a temperature sensor failure, this setting determines the length of a refrigeration cycle.

**Hpr Off**

In case of a temperature sensor failure, this setting determines the amount of time between refrigeration cycles.

**2.5 DRIVE BELT TENSION ADJUSTMENT**

To check belt tension, follow the steps below:

- A. Remove a side panel and the back panel.
- B. Use a Burroughs Belt Tension Gauge to set the tension for the drive belt. Set the belt tension to 40-50 lbs.
- C. If an adjustment is necessary, loosen the four motor plate retaining nuts, adjust belt tension then retighten the four nuts.

**NOTE**

*Belt life will be increased if new drive belts are checked after two or three weeks of operation.*

**2.6 PREVENTATIVE MAINTENANCE**

It is recommended that a maintenance schedule be followed to keep the machine clean and operating properly.

**A. DAILY****Disassemble and Clean**

The frequency of cleaning the freezer and freezer parts must comply with local health regulations. Refer to the previous sections for proper disassembly and cleaning instructions.

**Lubricate Front Wearguard**

Petrol Gel sanitary lubricant or equivalent must be used when lubrication of parts is specified. Apply a thin film of sanitary lubricant to the inside and outside of the front wearguard.

**Inspect Parts**

Inspection for worn or broken parts should be made each time the freezer is disassembled. All worn or broken parts should be replaced to ensure safety to both the operator and the customer and to maintain good freezer performance and a quality

**Lubricate Back End of the Auger**

Lubricate the rear of the auger with a small amount of spline lubricant.

**B. WEEKLY****Clean Inside Of Machine**

Remove all side panels and clean the inside of the machine. Wipe any custard that may have dripped onto the inner panels with a damp soapy towel. Wash the drain tray.

### C. MONTHLY

#### Clean Condenser Coils (And Filters If Applicable)

The coils on the hopper, dipping cabinet and remote condenser need to be cleaned to ensure proper airflow. Use compressed air to clean the condensers. Blow the air in the opposite direction of the normal airflow.

### C. QUARTERLY

#### Replace Barrel Parts According To Schedule

Follow the Parts Replacement Schedule below to keep the freezer operating properly.

### D. ANNUALLY

 <b>WARNING</b>
High voltage will shock, burn or cause death. Turn off and lock out main power disconnect before servicing. Do not operate machine with panels removed.

#### Replace Barrel Parts

Follow the Parts Replacement Schedule below to keep the freezer operating properly.

#### Drive Belt Wear and Tension

Inspect the drive belts for wear. Check for wear marks from the belts rubbing on the pulley. Press firmly on the belts. When tension is properly adjusted, the belt will depress the approximate width of the belt with the pressure of a finger. If you think the belt is out of tension consult the Owner's Manual or contact Stoelting Customer Service.

## 2.7 EXTENDED STORAGE

Refer to the following steps for storage of the machine over any long shutdown period:

- A. Turn the Main Freezer Power OFF-ON switch to the OFF position.
- B. Disconnect (unplug) from the electrical supply source.
- C. Clean all parts thoroughly with a warm water detergent. Rinse in clean water and dry parts. Do not sanitize.

#### NOTE

*Do not let the cleaning solution stand in the hopper or in the freezing cylinder during the shutdown period.*

- D. Remove, disassemble and clean the faceplate, flow control assembly and beater shaft parts. Place the blades and the beater shaft wear guard in a plastic bag with a moist paper towel to prevent them from becoming brittle.

Part	Description	3 Months	Annually	Qty per Barrel
C-2000-50	Spring		X	12
C-2000-51	Blade		X	12
SL-0010	Seal - Beater Shaft	X		1
149014	Bushing - Front Auger Support	X		1
625174	O-Ring - Front Door	X		1

**Figure 2-3 Parts Replacement Schedule**

## SECTION 3 TROUBLESHOOTING

### 3.1 ERROR CODES

When the machine experiences a problem, one of the following error codes will be displayed on the control panel. Each error code directs you to the system location of the malfunction.

#### ERROR CODE MALFUNCTION

1	Soft
2	High Torque
3	Extended Run Time
4	Clean
5	Barrel Sensor
6	Hopper Sensor
7	Drive Motor
8	Cab Sensor
9	High Pressure Cutout
10	Auxiliary Sensor

To return the machine to normal operation, any error causing condition must be corrected and the Main Freezer Power Off/On switch in the Off position and back in the On position before the machine will return to normal operation.

### 3.2 TROUBLESHOOTING ERROR CODES

#### Error Code 1 - Soft Error

The Soft Error (E1) is an internal control board error that is logged for future analysis. The refrigeration is never stopped and the machine will continue to operate normally.

#### Error Code 2 - High Torque

If the control panel displays a High Torque Error (E2), the drive motor is running at a high load for 10 or more seconds. Place the Main Freezer Power Off/On switch in the Off position, wait until the product in the freezing cylinder thaws to a reasonably soft consistency and return the switch to the On position. If the error persists, it could be a sign of very low and/or fluctuating supply voltage. The error can also be caused by faulty motor or starting components which could product a high amp draw.

#### Error Code 3 - Run Time

The Run Time Error (E3) occurs when the compressor runs continuously for an extended period. This error could happen if the cutout value is not attained during "Standby Mode" or if the "Ready" signal does not come on in "Custard Mode" or "Lemon Ice Mode".

The compressor will run continuously if a solenoid valve fails to open. This could be due to loose wiring, magnetic coil failure, a stuck valve or a faulty control board.

After the cause of the problem is found and remedied place the Main Freezer Power Off/On switch in the Off position and back in the On position.

#### Error Code 4 - Clean

If the machine is left in the Clean Mode for more than 20 minutes, the control panel will display a Clean Error (E4). This condition does not reflect a problem with the machine itself. The Clean Error has been programmed into the controller as a safeguard to protect the machine from potential damage caused by the machine being accidentally left in "Clean Mode". The control will attempt to restart itself after 5 minutes. The display will then flash and read Restart. To immediately clear the Clean Error, place the Main Freezer Power Off/On switch in the Off position and back in the On position. After the Clean Error has been cleared, the machine will start a refrigeration cycle to protect the product in case the clean button was pressed by mistake.

### Error Code 5 - Freezing Cylinder Sensor

The Freezing Cylinder Sensor Error (E5) indicates a failure of the freezing cylinder sensor or if the sensor is out of range. If the control panel displays an E5, place the Main Freezer Power Off/On switch in the Off position and back in the On position. If the control panel still displays the error code, refer to the machine's wiring diagram and the Temperature Sensor Chart (Figure 3-1). Check each lead of the sensor to ground for continuity. If continuity is found, replace the sensor. To check the resistance of the sensor, place a thermocouple on the suction line at the exit of the freezing cylinder. Compare temperature and sensor resistance with the table as reference. If measured value does not coincide with a value on the table ( $\pm 400$  ohms), replace the sensor.

#### NOTE

*When the machine encounters a Freezing Cylinder Sensor Error, the machine will continue to run using timers. This mode will allow the machine to continue making product until the machine is serviced.*

### Error Code 6 - Hopper Sensor

The Hopper Sensor Error (E6) indicates a failure of the hopper sensor or if the sensor is out of range. If the control panel displays an E6, place the Main Freezer Power Off/On switch in the Off position and back in the On position. If the control panel still displays the error condition code, refer to the machine's wiring diagram and the Temperature Sensor Chart (Figure 3-1). Check each lead of the sensor to ground for continuity. If continuity is

found, replace the sensor. To check the resistance of the sensor, place a thermocouple on the suction line at the exit of the freezing cylinder. Compare temperature and sensor resistance with the table as reference. If measured value does not coincide with a value on the table ( $\pm 400$  ohms), replace the sensor.

### Error Code 7 - Drive Motor

If the control panel displays a Drive Motor Error (E7), the control does not sense current coming from the drive motor. Place the Main Freezer Power Off/On switch in the Off position and back in the On position. If the error returns, use the machine's wiring diagram and check connections at the IntelliTec control and at the motor. An E7 may also be the result of a faulty drive motor contactor.

### Error Code 8 - Cab Sensor

A Cab Sensor Error (E8) will not occur on the CC model machines.

### Error Code 9 - High Pressure Cutout

High Pressure Cutout Errors (E9) are usually caused by a dirty or inefficient condenser. If the control panel displays an E9, place the Main Freezer Power Off/On switch in the Off position and back in the On position.

In air cooled condenser models, check for proper air clearance around the condenser and be sure condenser fan is functioning.

On water cooled condenser models, check for proper water flow through the condenser coil.

After the cause of the error is determined and corrected, place the Main Freezer Power Off/On switch in the Off position and back in the On position.

### Error Code 10 - Auxiliary Sensor

An Auxiliary Temperature Sensor Error (E10) occurs if the temperature sensor on the control board fails. Place the Main Freezer Power Off/On switch in the Off position and back in the On position. If there is an E10 the control board may be faulty.

### ALTERNATING FLASHING CONTROL PANEL LIGHTS

The display panel lights will flash in an alternating sequence under any error codes. Clear the error and place the Freezing Cylinder Off/On switch in the OFF position and back in the ON position.

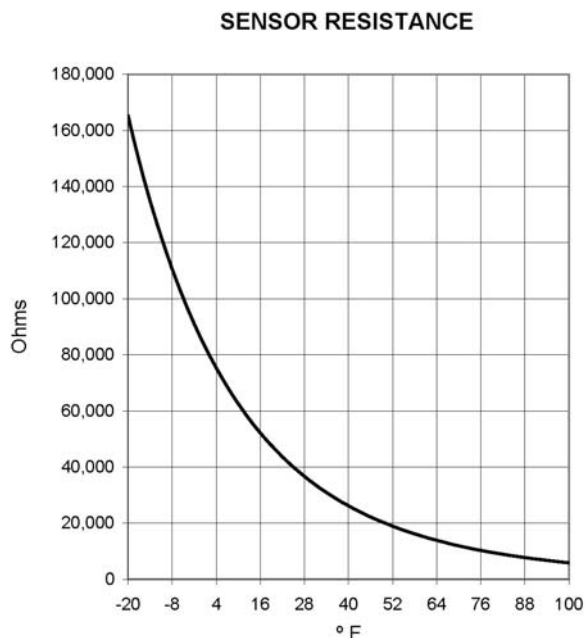

**Figure 3-1 Temperature Sensor Resistance (10k Ohms)**

### 3.3 TROUBLESHOOTING

PROBLEM	POSSIBLE CAUSE	REMEDY
<b>Custard is running too cold or auger blades chatter during running.</b>	<ol style="list-style-type: none"> <li>1 Flow is not high enough.</li> <li>2 Hopper is low or out of mix.</li> <li>3 Flow valve is plugged.</li> <li>4 The refrigeration system is set too cold for the mix.</li> </ol>	<ol style="list-style-type: none"> <li>1 Increase the flow. Machine needs to run for at least a minute before you see a change in the product.</li> <li>2 Add Mix</li> <li>3 Check flow valve.</li> <li>4 Call Stoelting service department and we can help over the phone to adjust setting properly.</li> </ol>
<b>Custard is running too soft.</b>	<ol style="list-style-type: none"> <li>1 Flow is too high.</li> <li>2 The refrigeration system for that barrel set too warm for the mix.</li> <li>3 Condenser on remote unit is blocked.</li> <li>4 Water cooled machine has water shut off.</li> <li>5 Refrigeration system not functioning correctly.</li> </ol>	<ol style="list-style-type: none"> <li>1 Decrease the flow. Machine needs to run for at least a minute before you see a change in the product.</li> <li>2 Call Stoelting service department and we can help over the phone to adjust setting properly.</li> <li>3 Check for blockage and clean if necessary.</li> <li>4 Check that water is connected and turned on.</li> <li>5 Call Stoelting service department.</li> </ol>
<b>Beater motor freezes up in the run mode.</b>	<ol style="list-style-type: none"> <li>1 Hopper is low or out of mix.</li> <li>2 Flow valve is plugged.</li> <li>3 Flow valve is set too low.</li> <li>4 Belt is loose and slipping.</li> </ol>	<ol style="list-style-type: none"> <li>1 Add Mix</li> <li>2 Check flow valve.</li> <li>3 Increase the flow setting.</li> <li>4 Check the belt and tighten if necessary.</li> </ol>
<b>Restriction of custard or lemon ice in the faceplate</b>	<ol style="list-style-type: none"> <li>1 Restriction in the faceplate.</li> <li>2 Solid obstruction in faceplate.</li> </ol>	<ol style="list-style-type: none"> <li>1 Use the rake to free the restriction and increase the flow rate setting by about 0.5. After a minute, repeat these steps if no results are seen.</li> <li>2 Inspect the flow valve for solid custard or lemon pulp obstruction in the hopper.</li> </ol>



# SECTION 4 REFRIGERATION & WIRING DIAGRAMS

## 4.1 REFRIGERATION DIAGRAMS

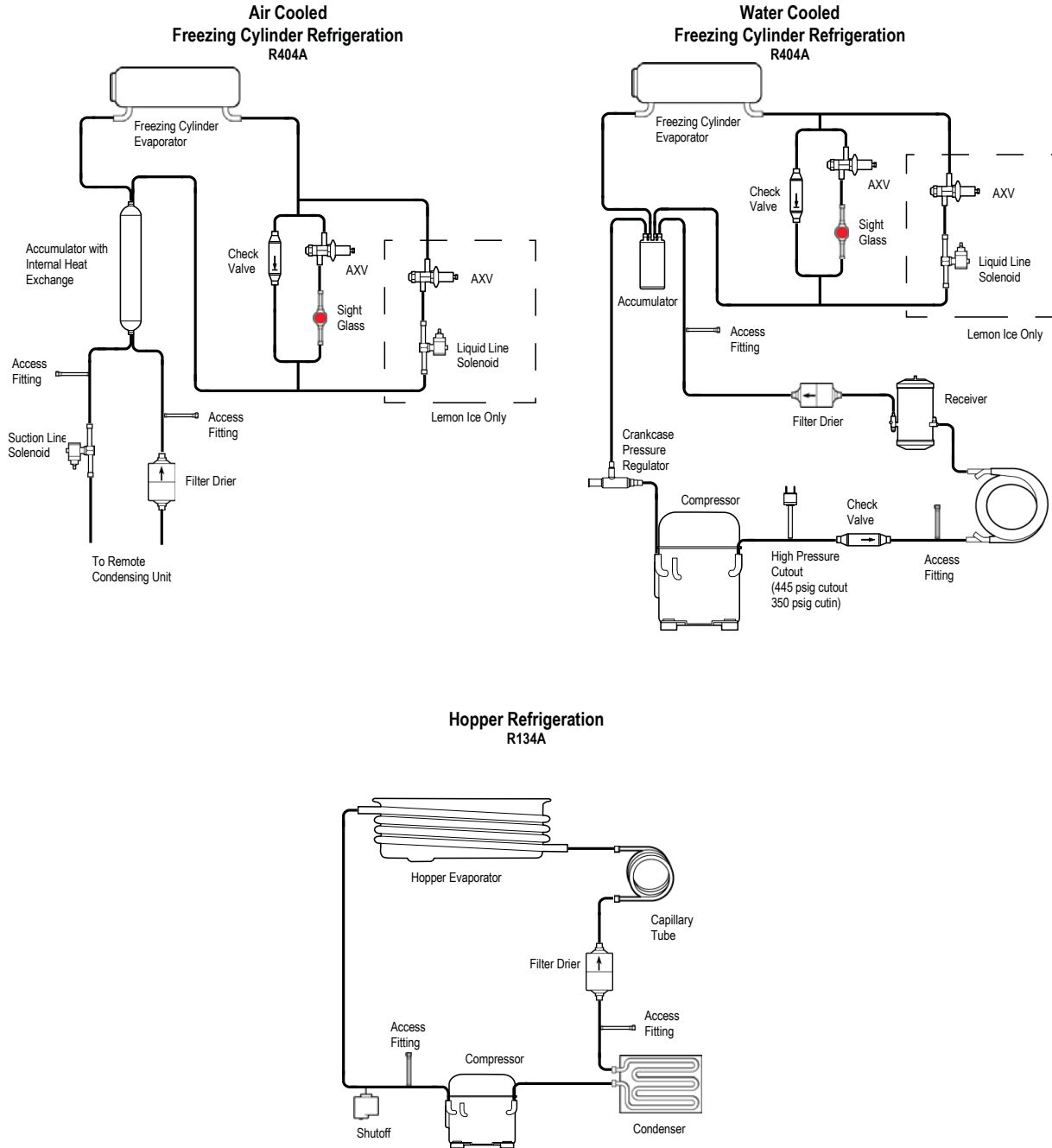

## 4.2 WIRING DIAGRAMS

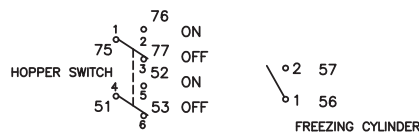
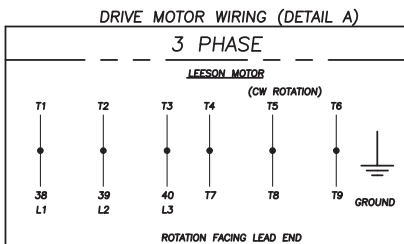
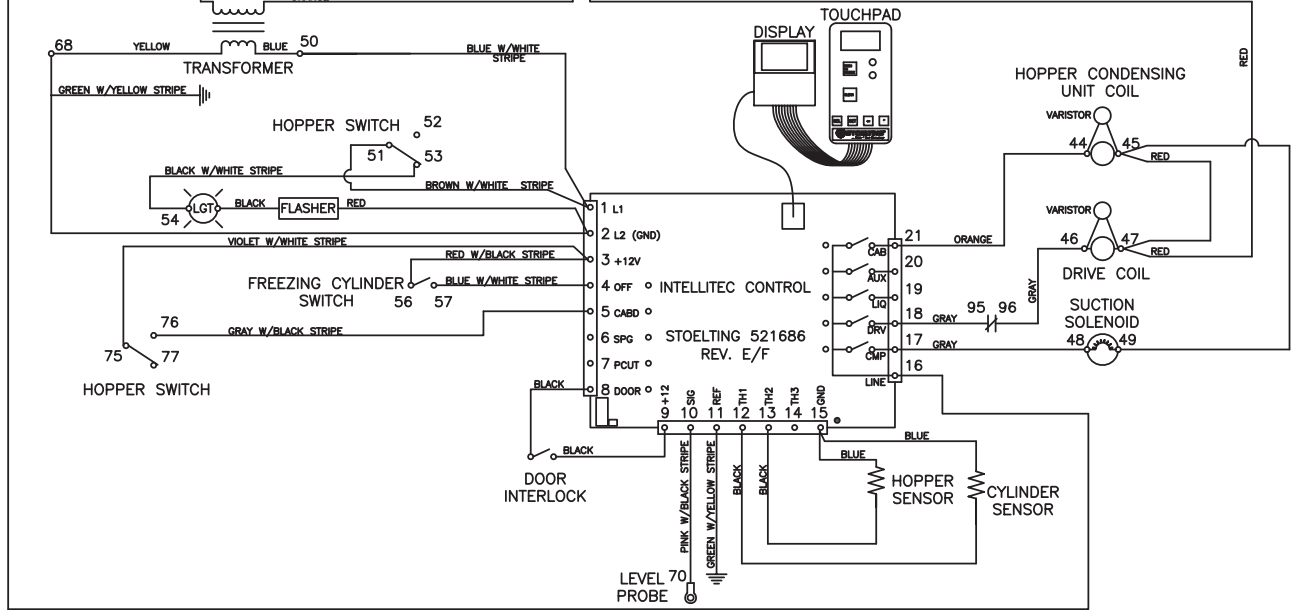
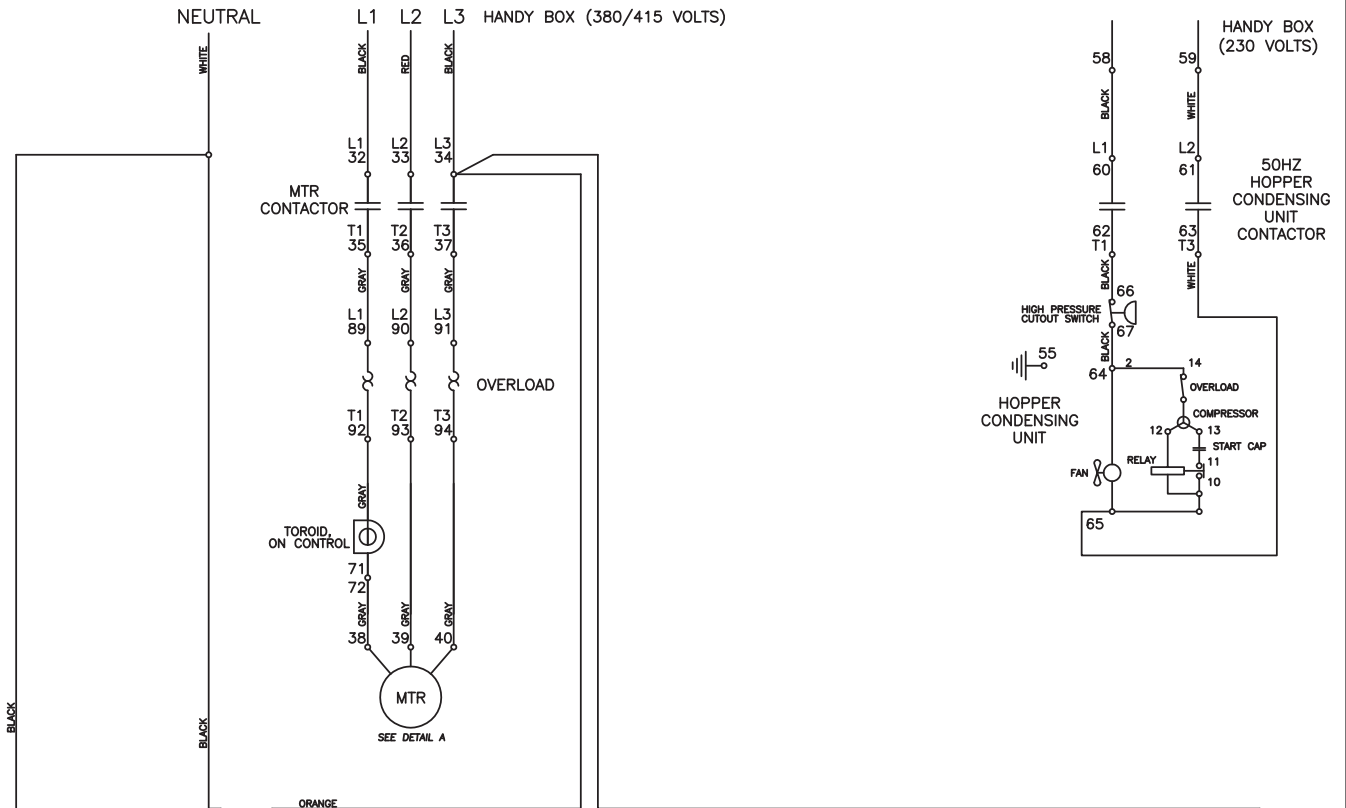

NO VARISTORS FOR 380/415 50HZ UNITS  
DRIVE & COMPRESSOR LOADS

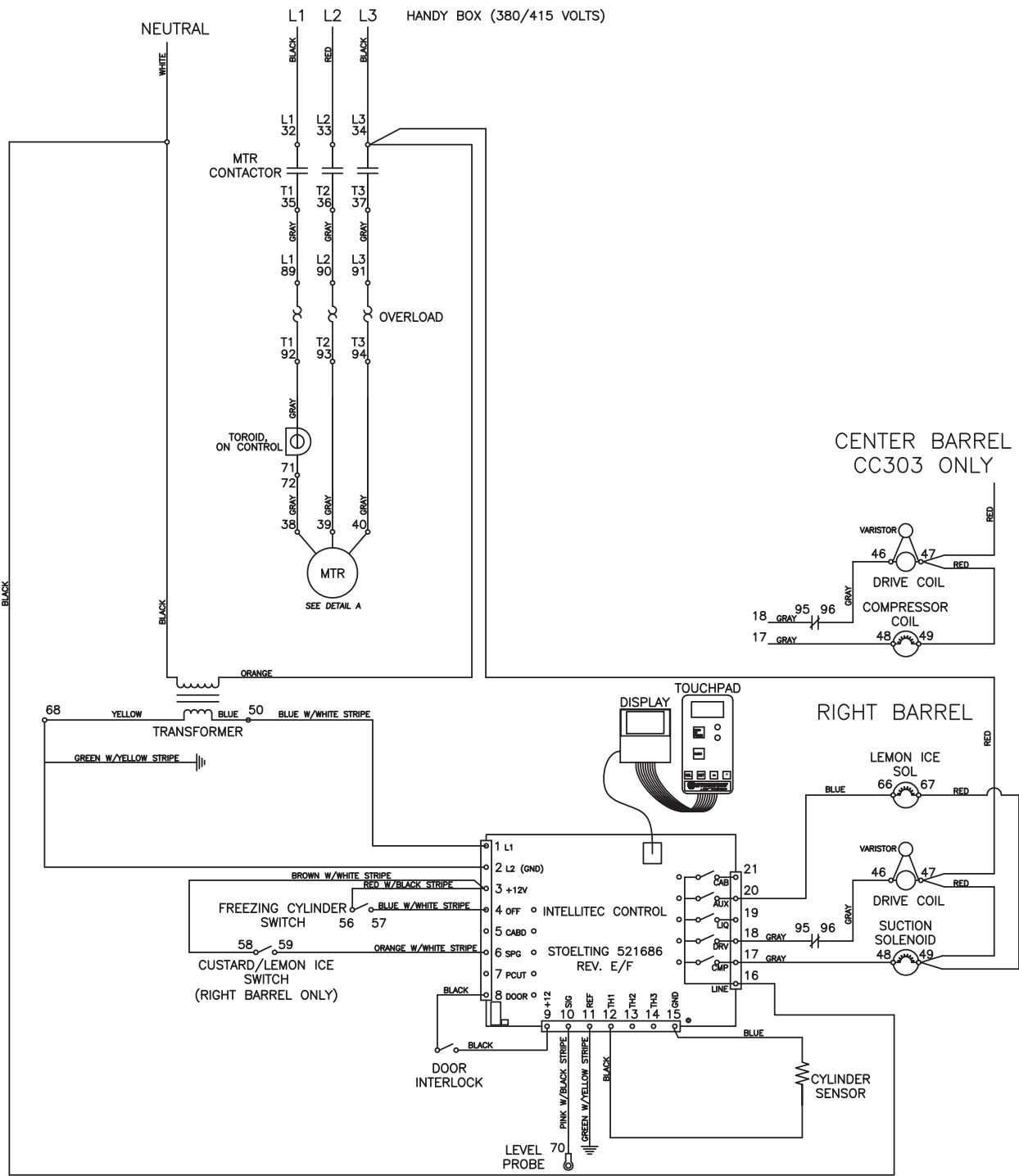

DRIVE MOTOR WIRING (DETAIL A)

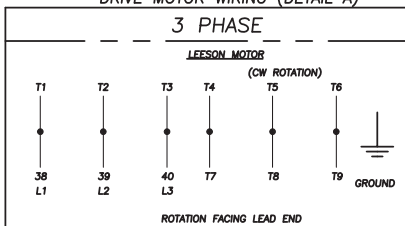

NO VARISTORS FOR 380/415 UNITS  
DRIVE & COMPRESSOR LOADS

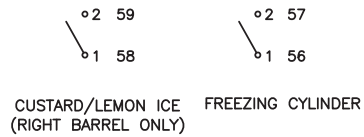

LEMON ICE SOLENOID  
(RIGHT BARREL ONLY)



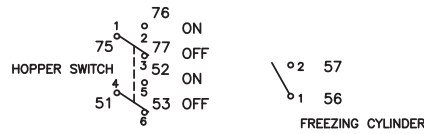
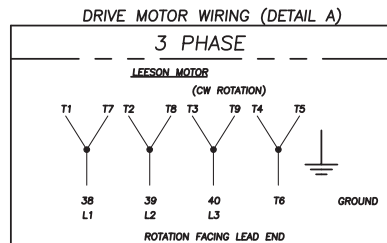
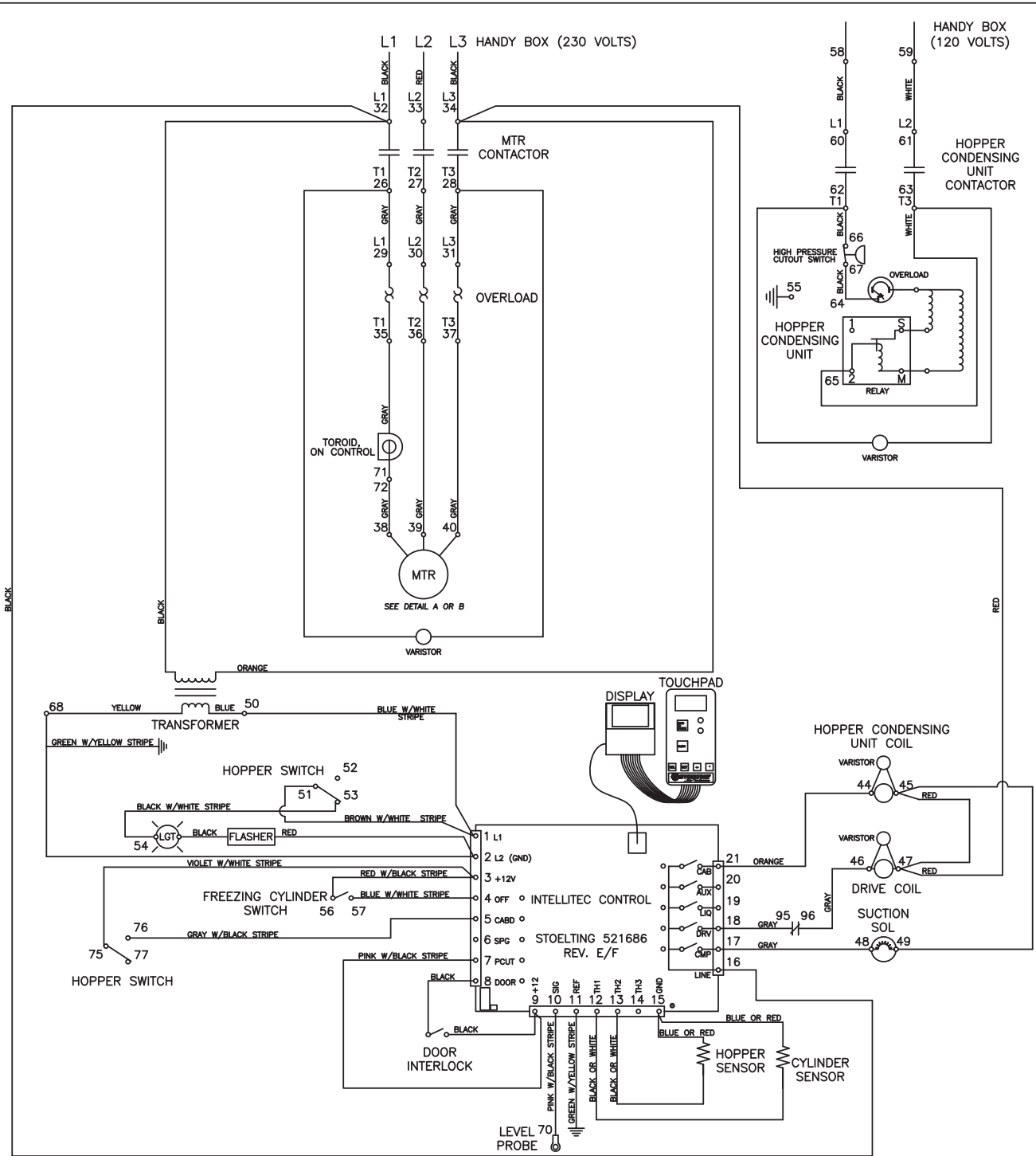

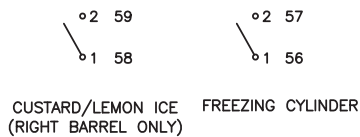
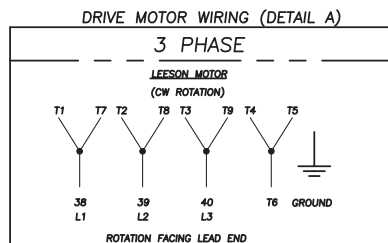
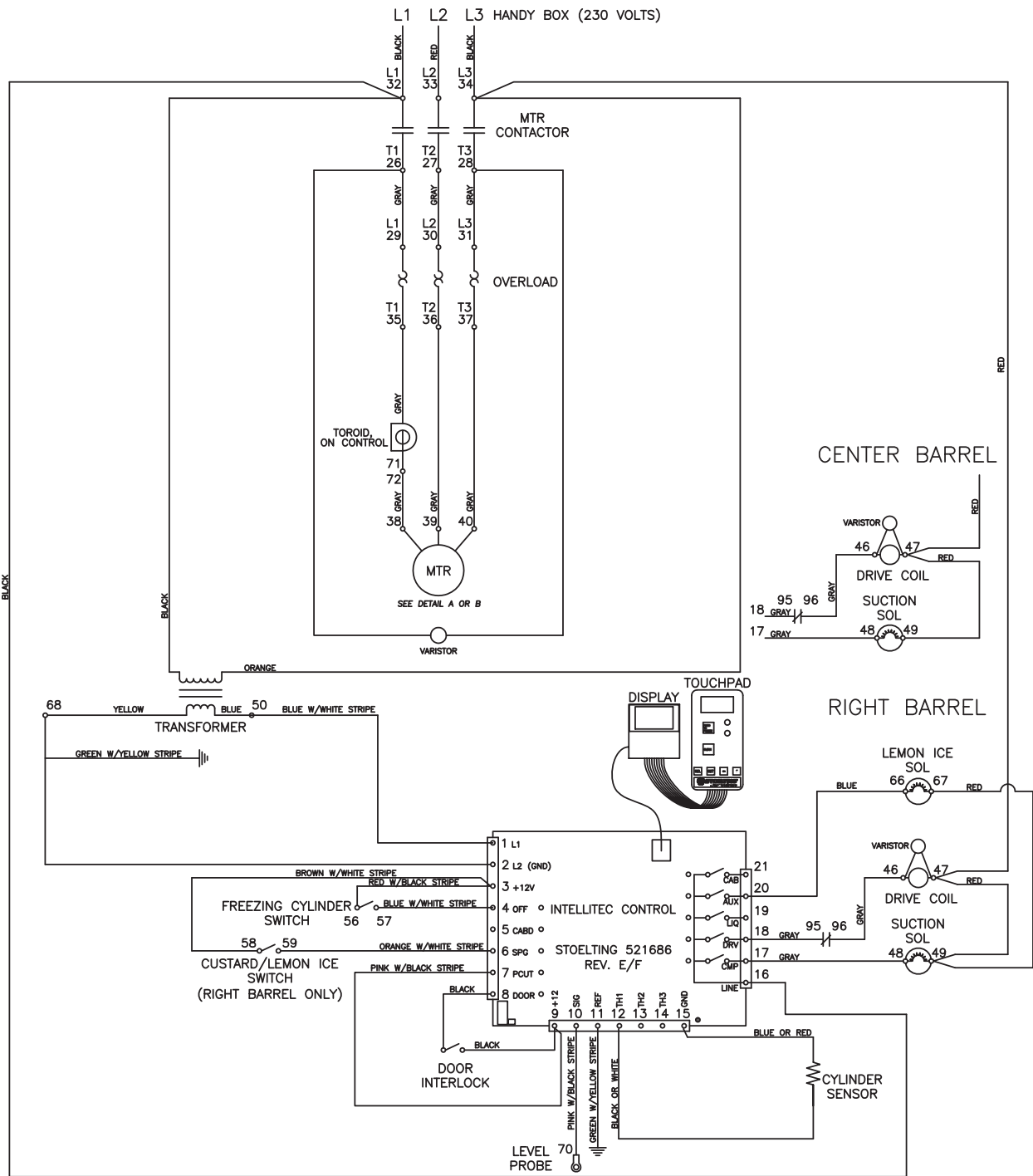

LEMON ICE SOLENOID  
(RIGHT BARREL ONLY)



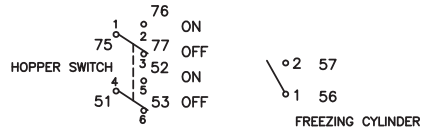
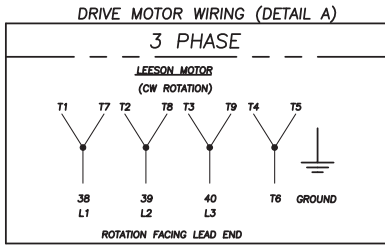
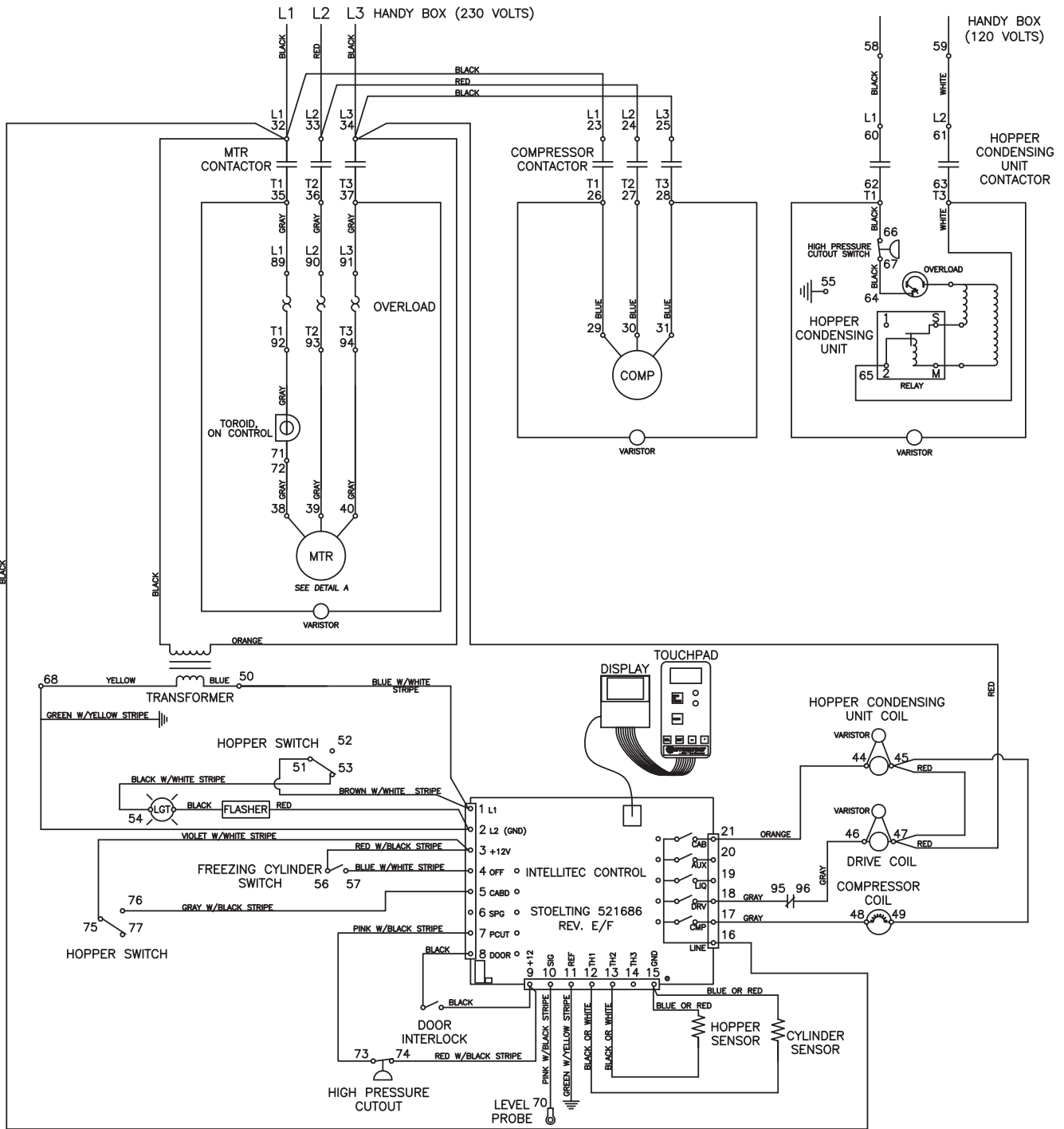

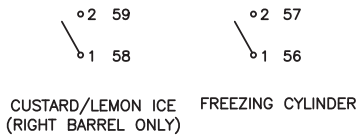
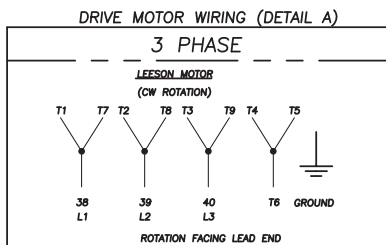
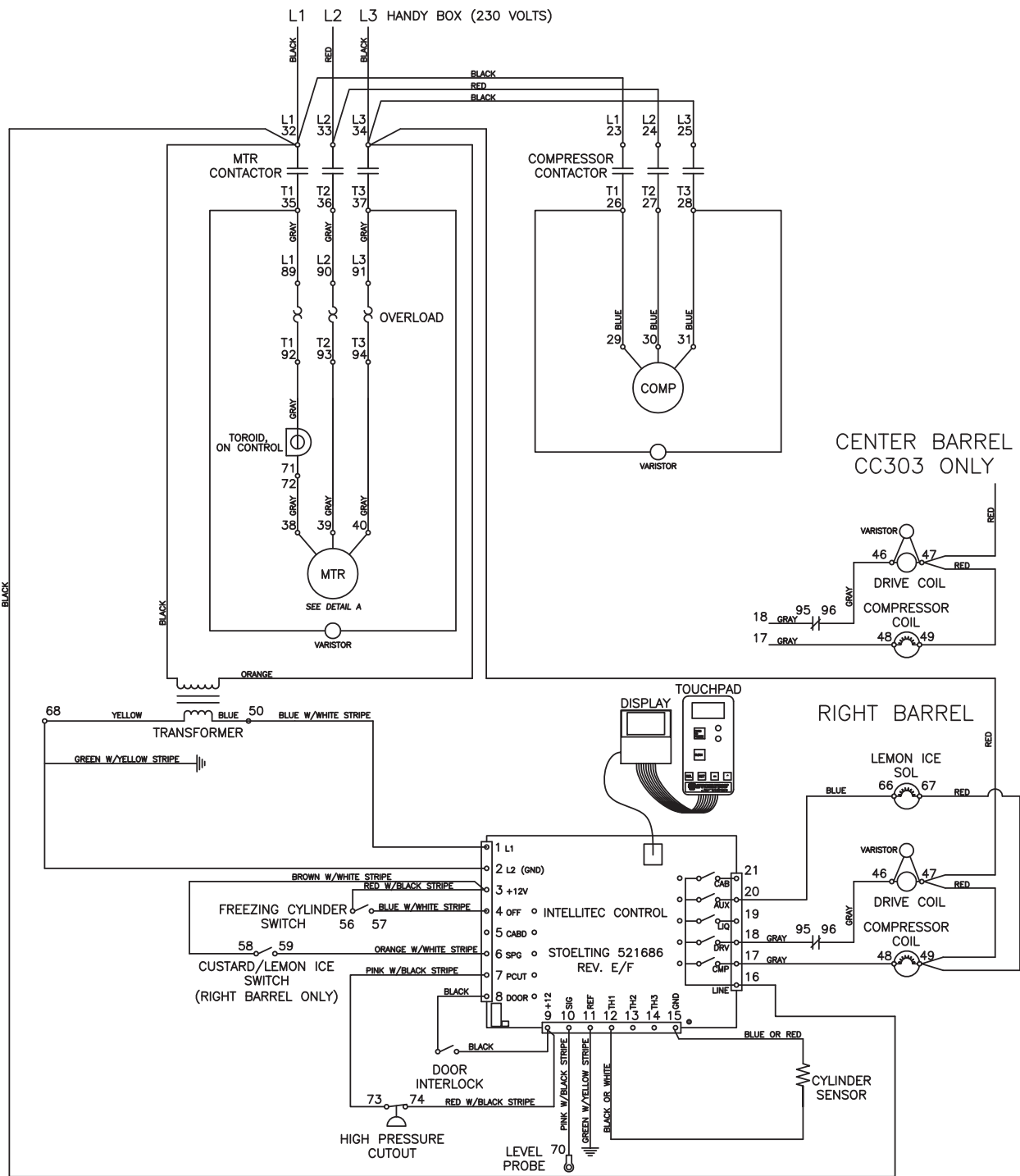

LEMON ICE SOLENOID  
(RIGHT BARREL ONLY)



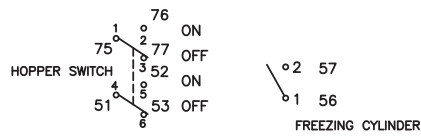
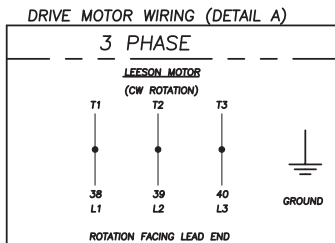
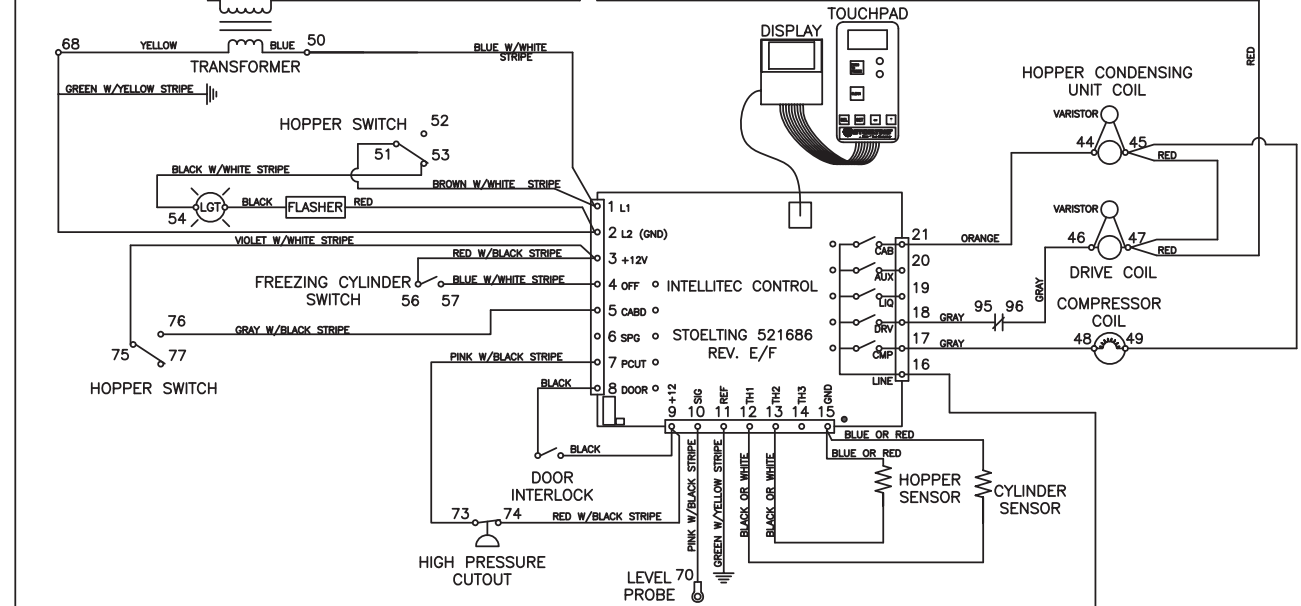
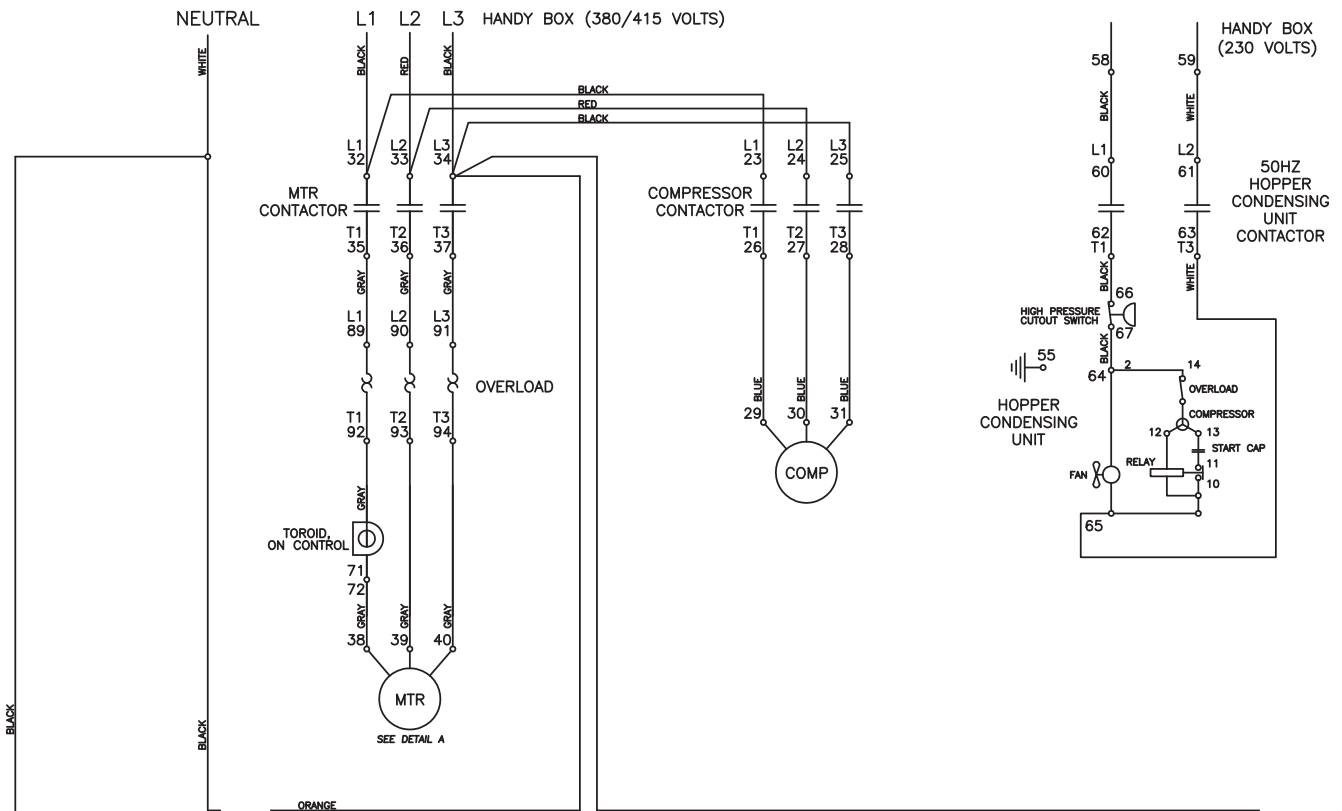

NO VARISTORS FOR 380/415 50HZ UNITS  
DRIVE & COMPRESSOR LOADS

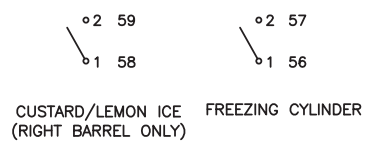
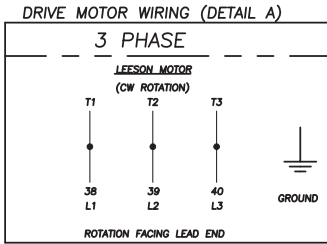
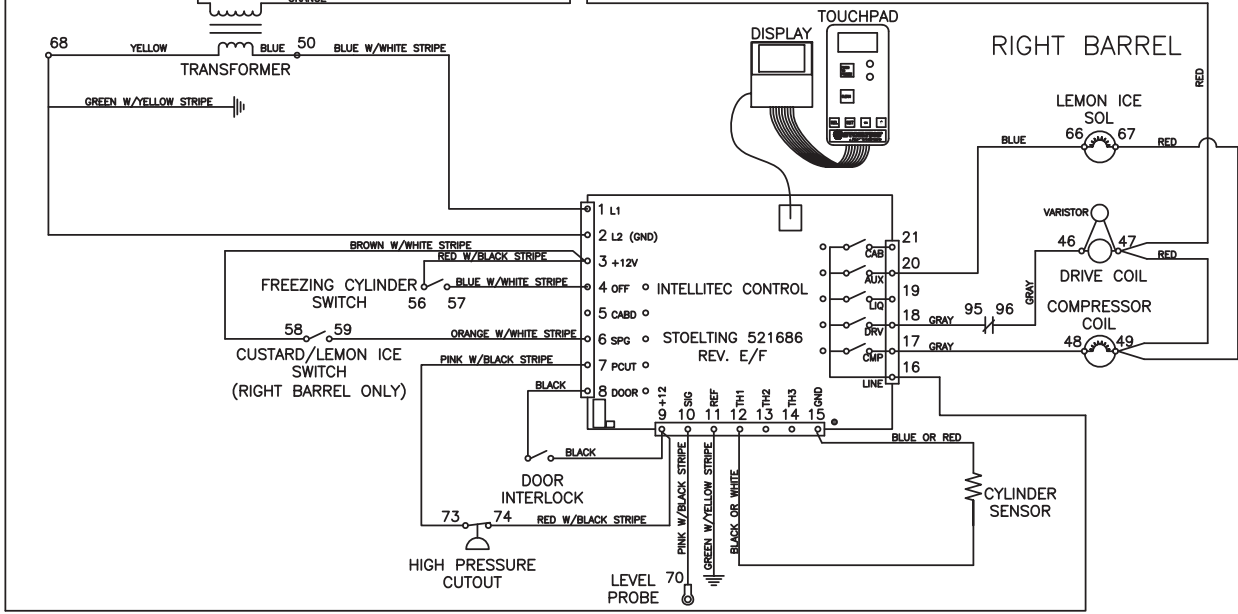
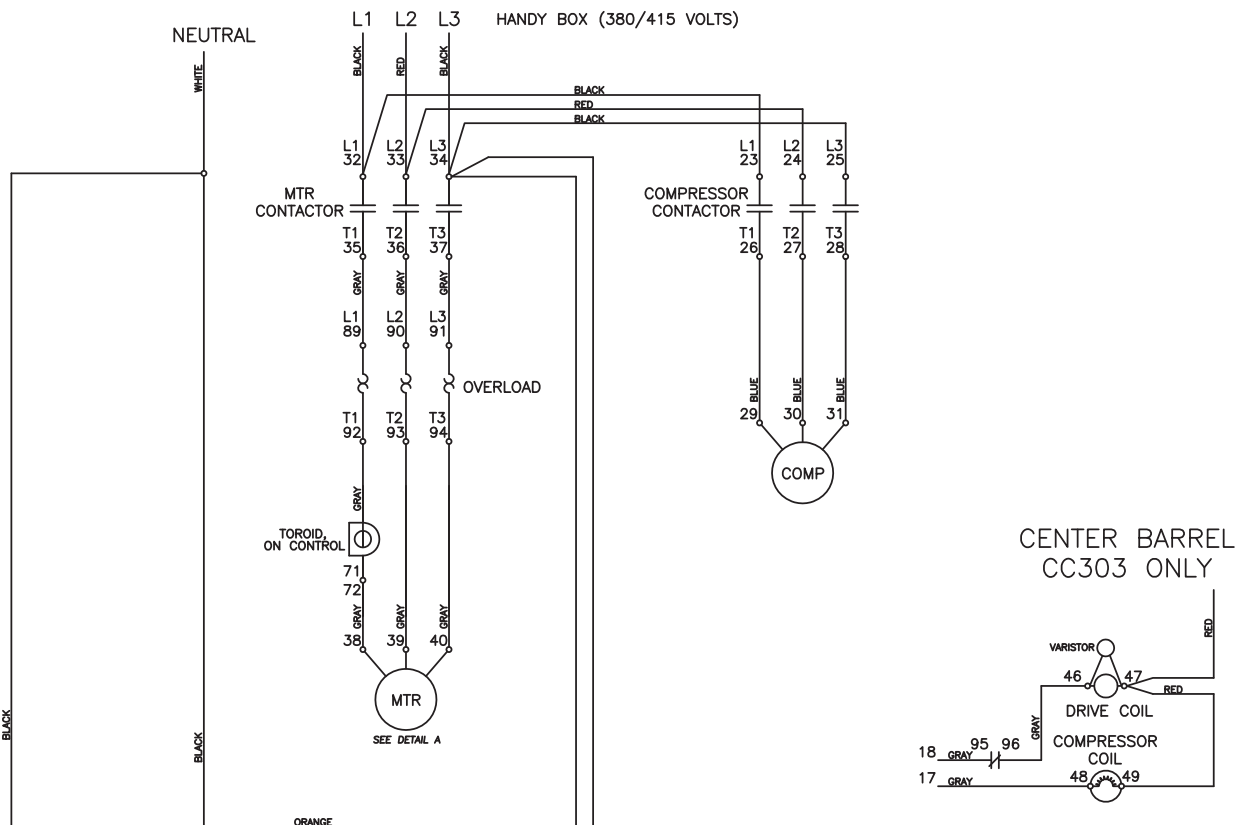

NO VARISTORS FOR 380/415 UNITS  
DRIVE & COMPRESSOR LOADS

LEMON ICE SOLENOID  
(RIGHT BARREL ONLY)



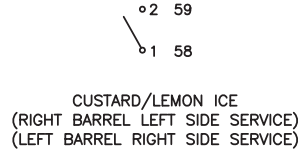
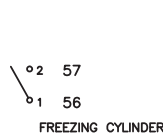
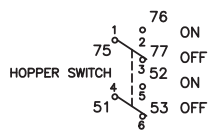
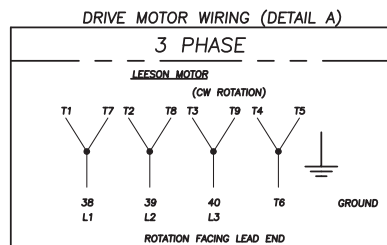
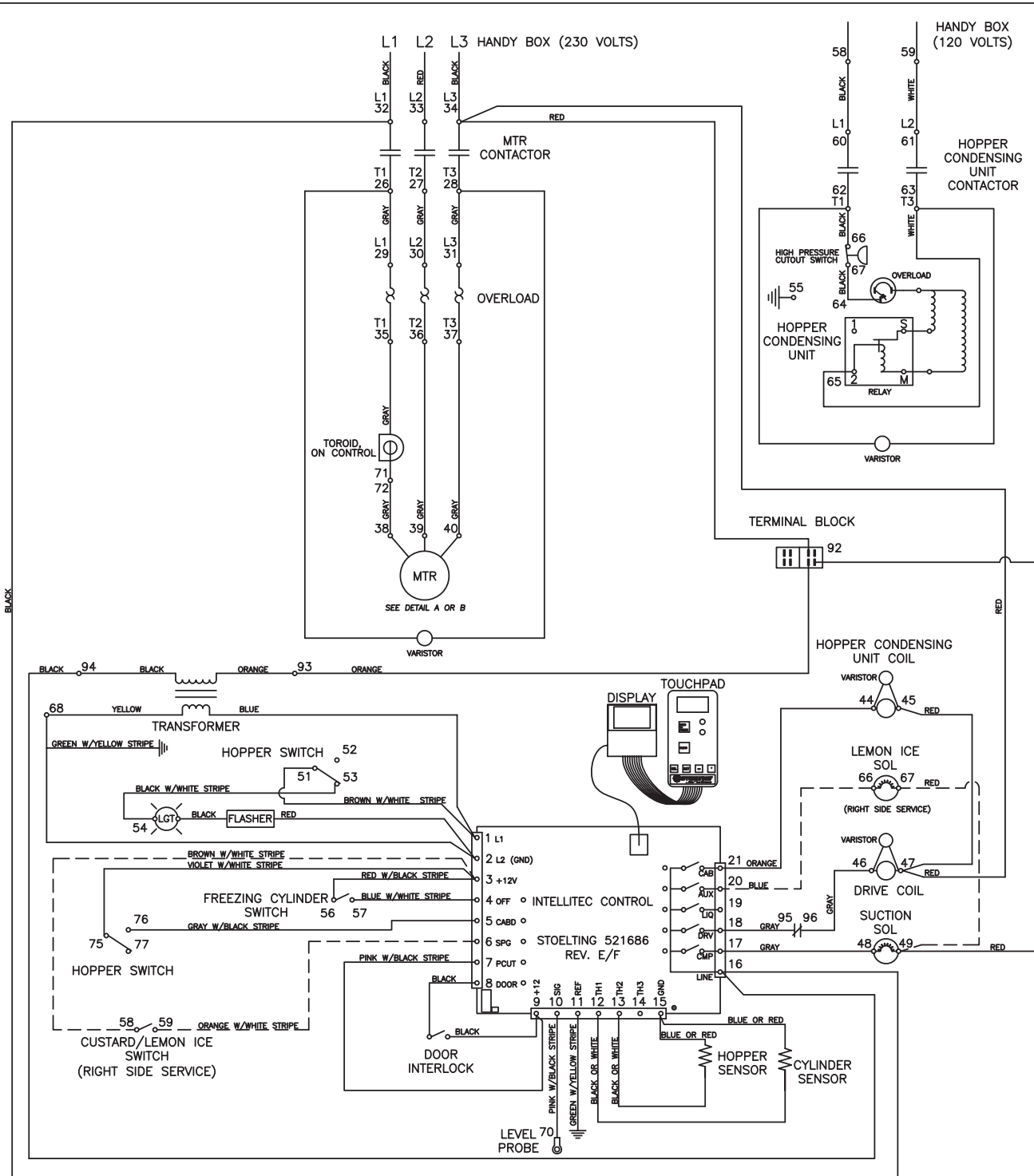

HOPPER (LEFT BARREL FOR LEFT SIDE SERVICE)  
HOPPER (RIGHT BARREL FOR RIGHT SIDE SERVICE)

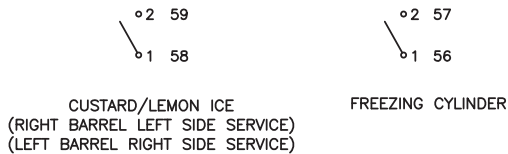
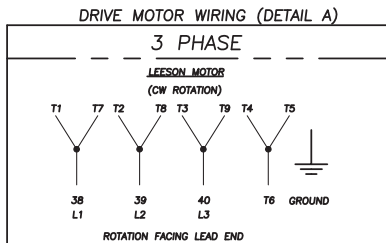
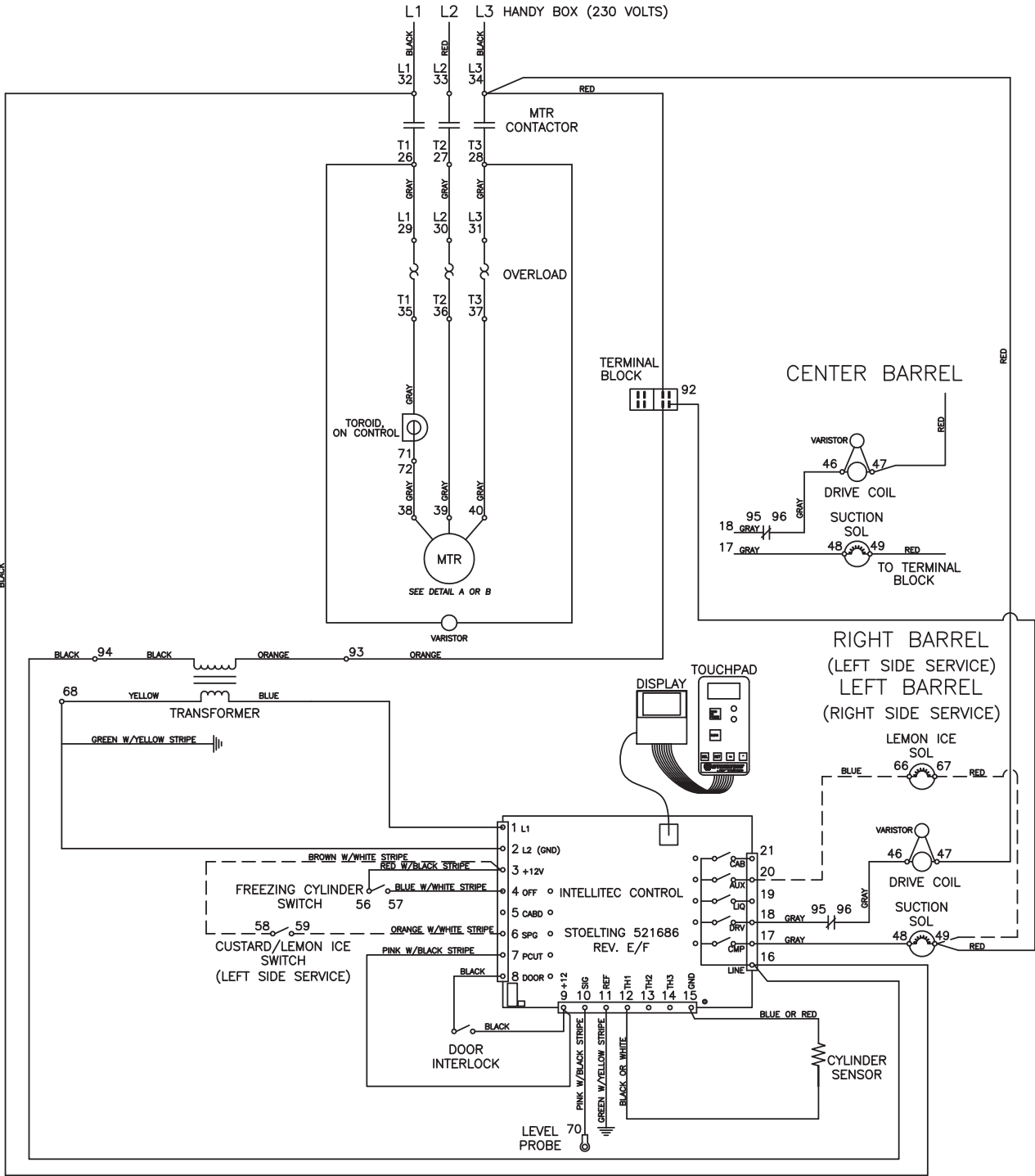

LEMON ICE SOLENOID  
(RIGHT BARREL ONLY)  
LEFT SIDE SERVICE

LEMON ICE SOLENOID  
(LEFT BARREL ONLY)  
RIGHT SIDE SERVICE



FROZEN CUSTARD INTELLITEC WIRING DIAGRAM

DRAWING NO. 2203315RC-WD

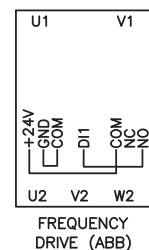
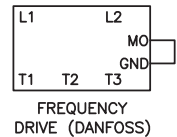
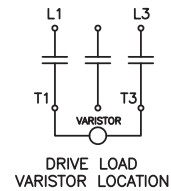
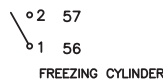
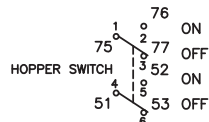
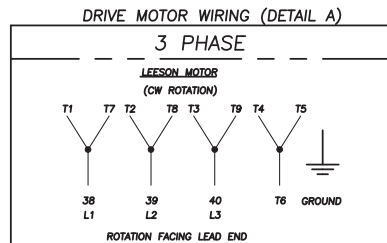
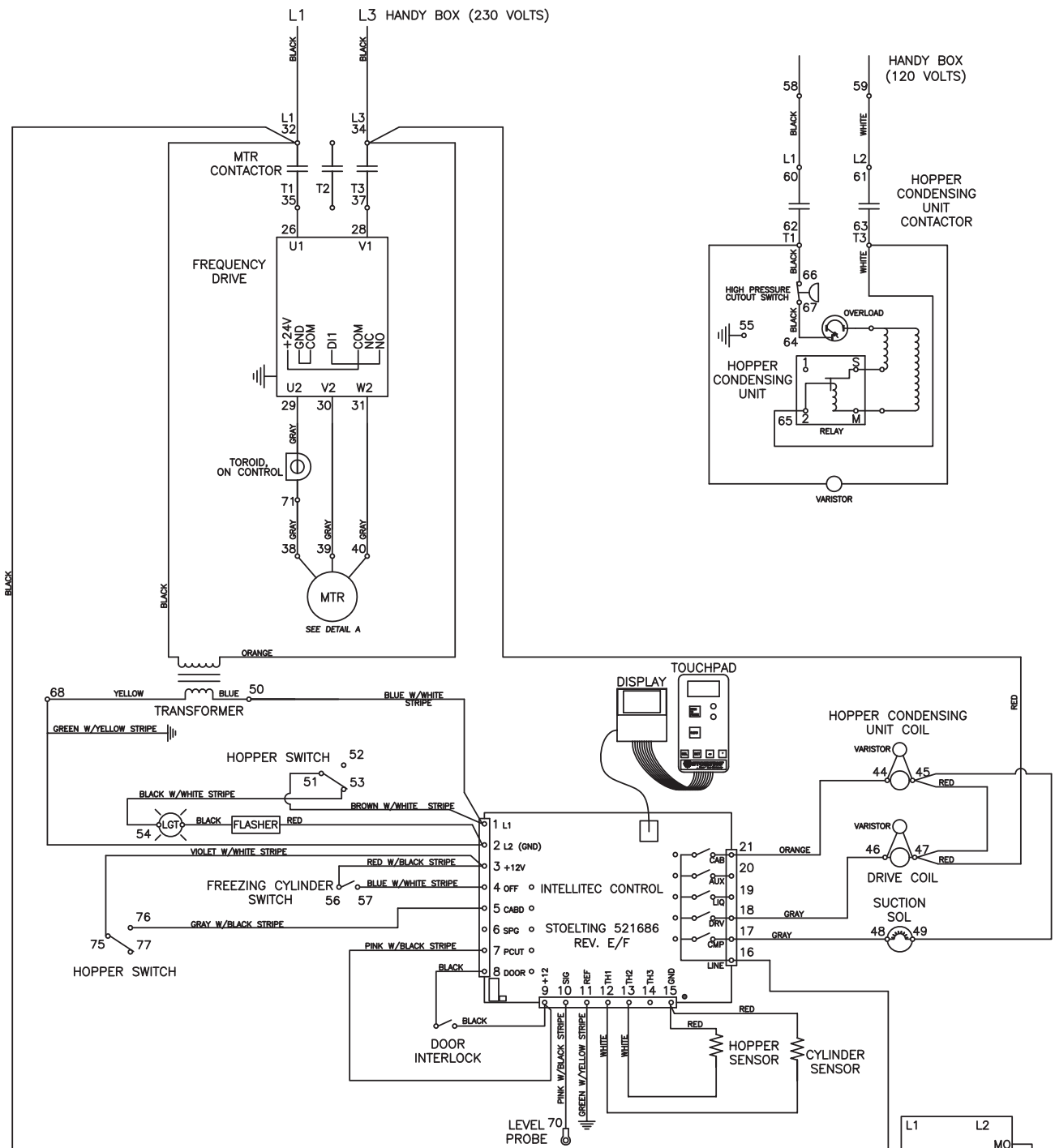

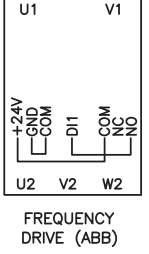
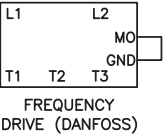
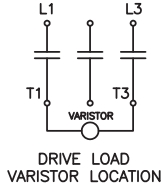
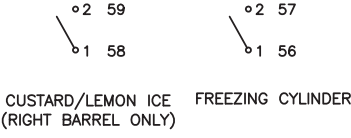
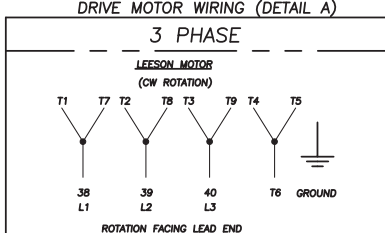
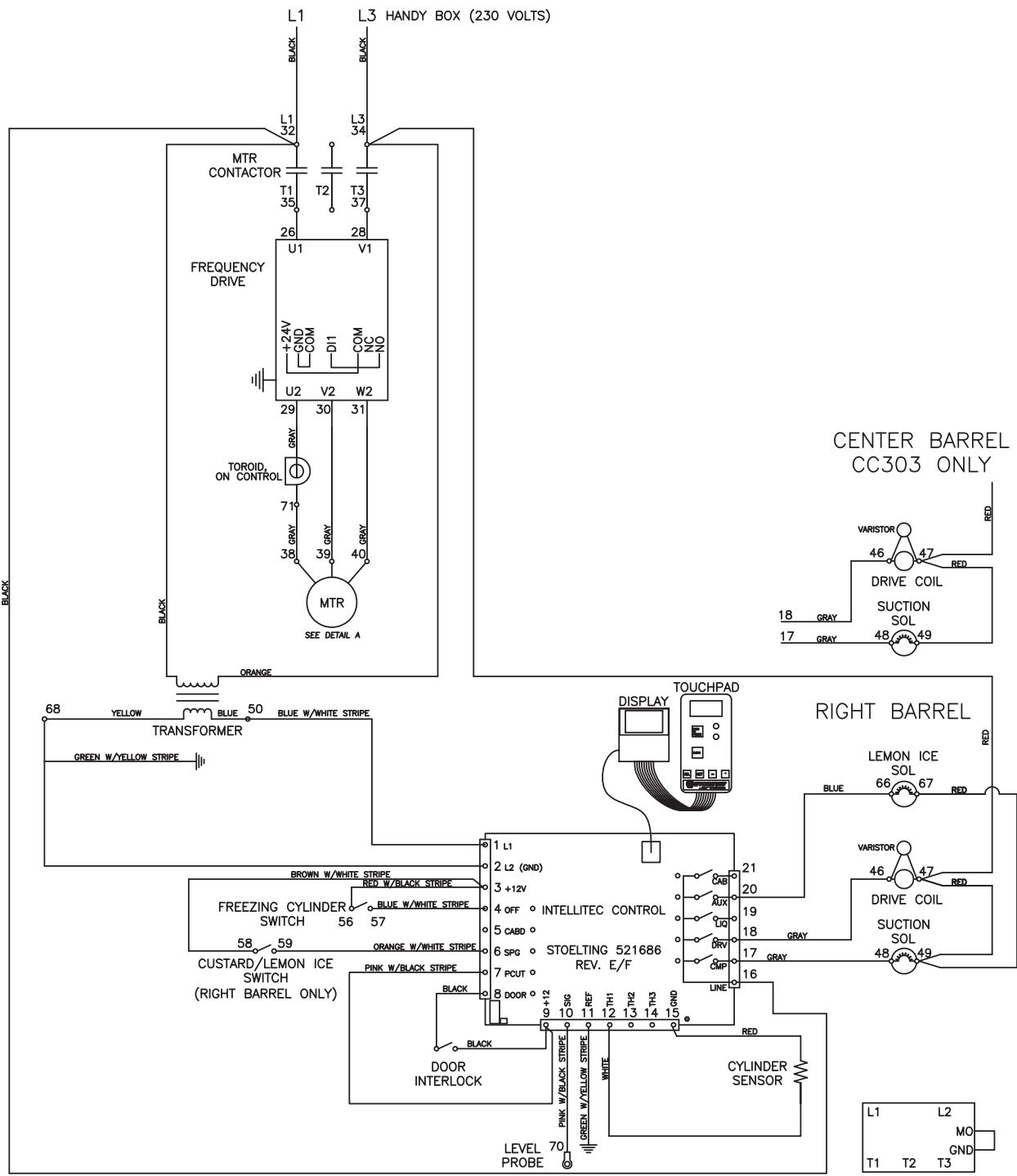

FROZEN CUSTARD INTELLITEC WIRING DIAGRAM

DRAWING NO. 2203505RC-WD

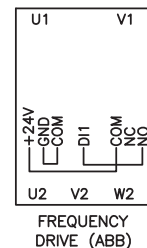
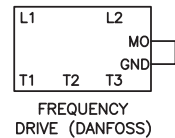
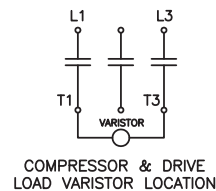
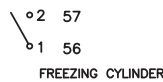
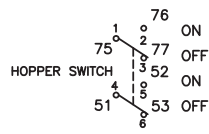
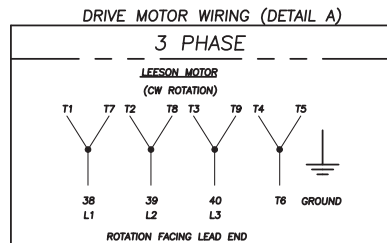
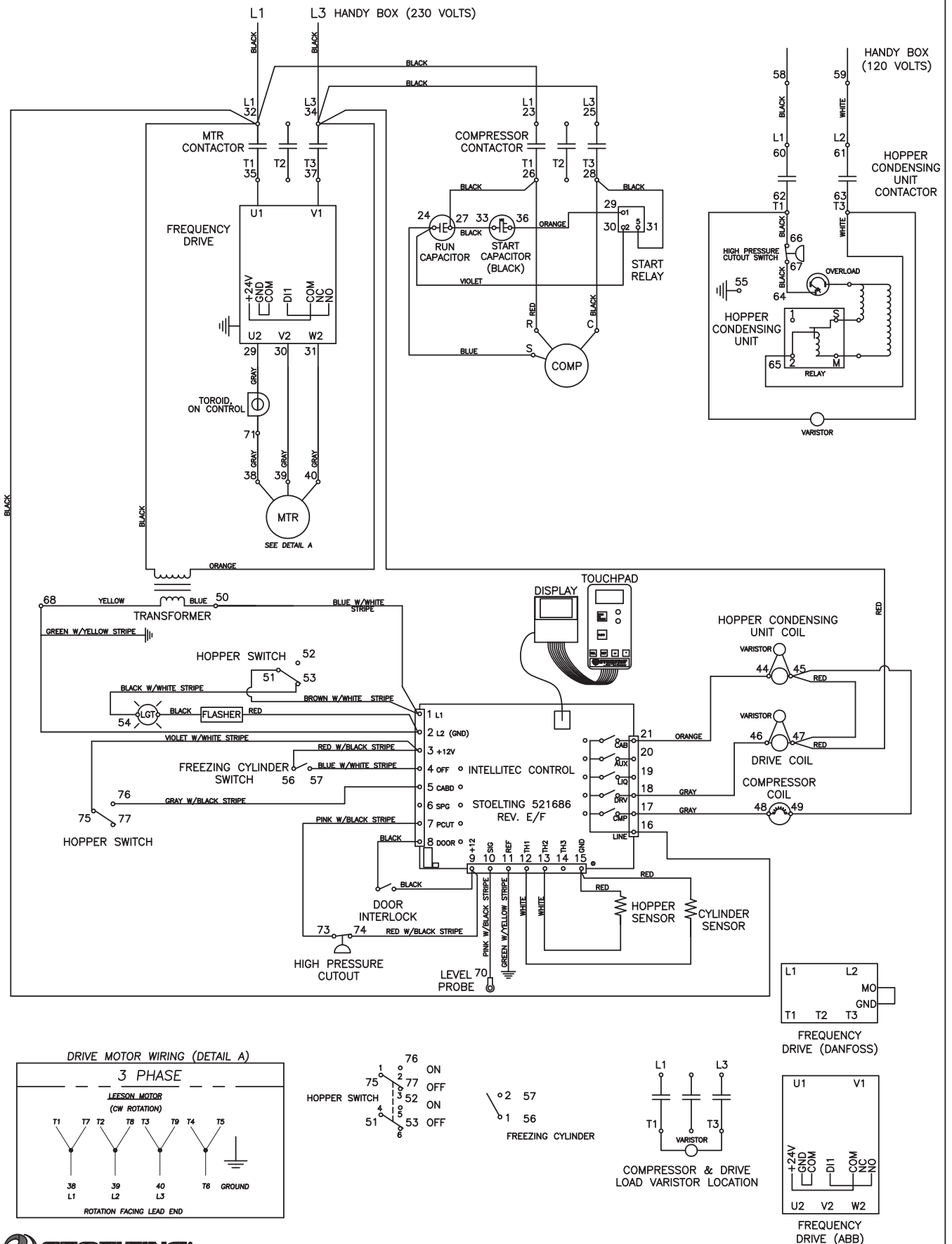

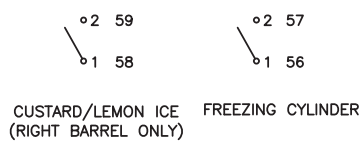
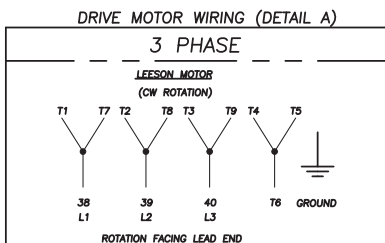
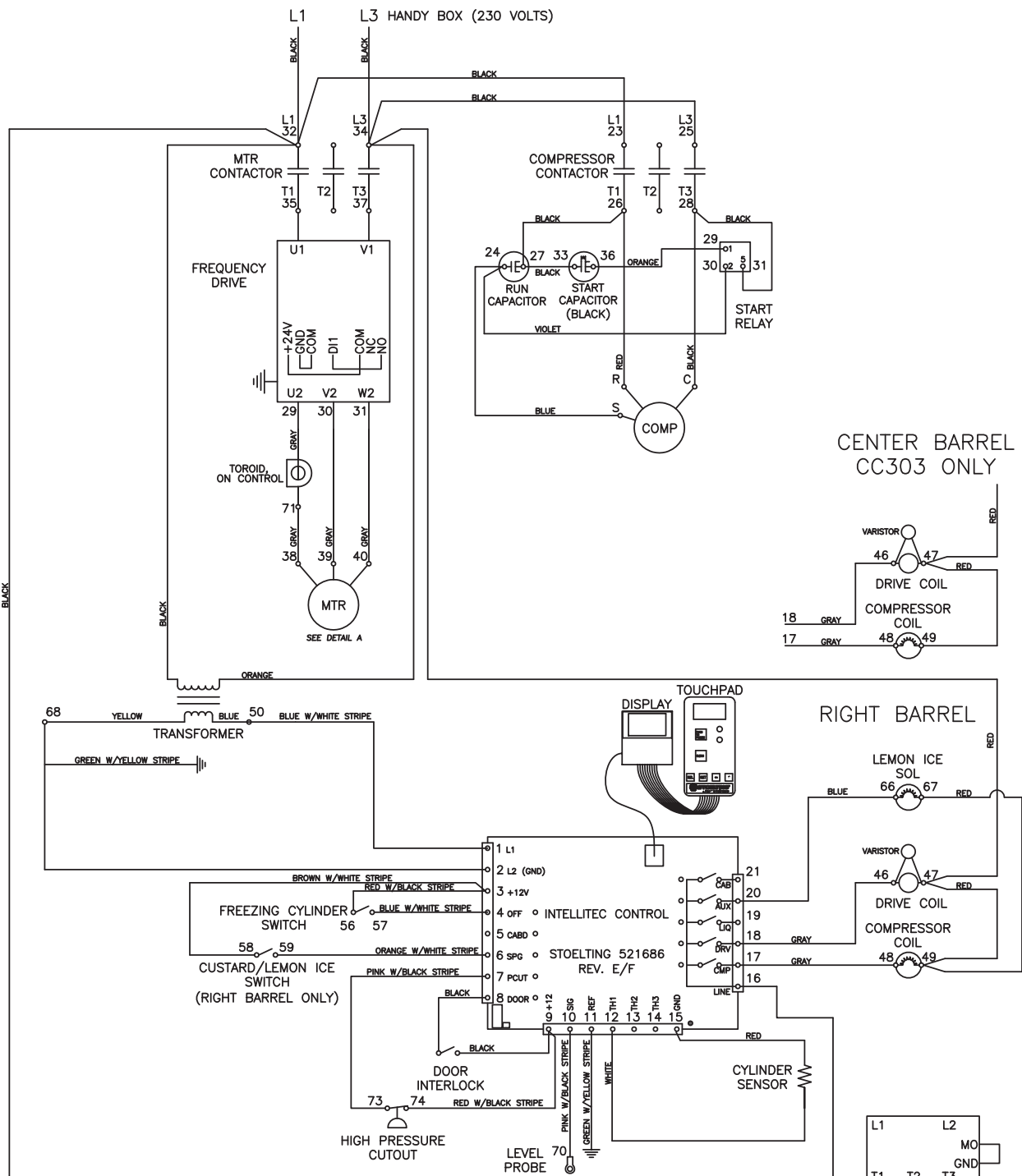

LEMON ICE SOLENOID (RIGHT BARREL ONLY)

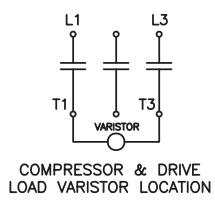

FREQUENCY DRIVE (DANFOSS)

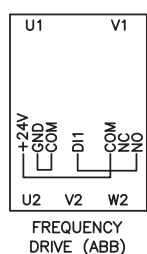



## SECTION 5 REPLACEMENT PARTS

### 5.1 BRUSHES, DECALS AND MISCELLANEOUS

Part Number	Description	Quantity
BR-0020	Brush - Tubing (1/2")	1
BR-0030	Brush - Head w/Handle	1
BR-0035	Brush - Handle (Barrel)	1
C74	O-Ring Pick	1
C-1000-25F	Decal - Caution 100 Degree	2
C-1000-25I	Decal - L.H. Barrel	1
C-1000-25J	Decal - Center Barrel	1
C-1000-25K	Decal - R.H. Barrel	1
C-1000-26C	Decal - Made In USA	1
C-2000-57	Wrench - Beater Shaft	1
C-4000-14	Guard Splash	1
236058	Card - Cleaning Instructions	1
236070	Card - IntelliTec - Assembly & Sanitizing (Culver's)	1
236071	Card - IntelliTec - Start & Stop Production (Culver's)	1
236072	Card - IntelliTec - Disassembly & Cleaning (Culver's)	1
244138	Caster - Non-Locking (4") (Each)	2
244139	Caster - Locking (4") (Each)	2
324065	Decal - Water Inlet	-
324105	Decal - Caution Electrical Shock	-
324106	Decal - Caution Electrical Wiring Materials	-
324141	Decal - Caution Rotating Blades	-
324208	Decal - Attention Refrigerant Leak Check	-
324346	Decal - Caution Hazardous Moving Parts	-
324509	Decal - Cleaning Instructions	-
324566	Decal - Wired According To	-
324594	Decal - Attention Heat Sensitive	2
324686	Decal - Danger Automatic Start	2
324890	Decal - Hopper Off	1
324894	Decal - Flow Control	1 per barrel
324900	Decal - Safety Warning Alert (Open Market)	1
324905	Decal - Danger (Culver's)	2
324907	Decal - Holding Product	1
430165	Cord - Power	1
490760	Leg	4
508048	Lubricant - Spline (2 oz Squeeze Tube)	1
508135	Petrol Gel - 4 oz Tube	1
513642	Manual - Owner's	1
756095	Tubing - 5/8" ID - Rear Drain Hose (25' Increments) (Per Inch)	-
764385	Valve Kit - Water Valve Repair	-
2202377	Pin Cleaning Tool - Front Plate	1
2203790	Sensor Probe Kit	-

## 5.2 AUGER SHAFT AND FACEPLATE PARTS

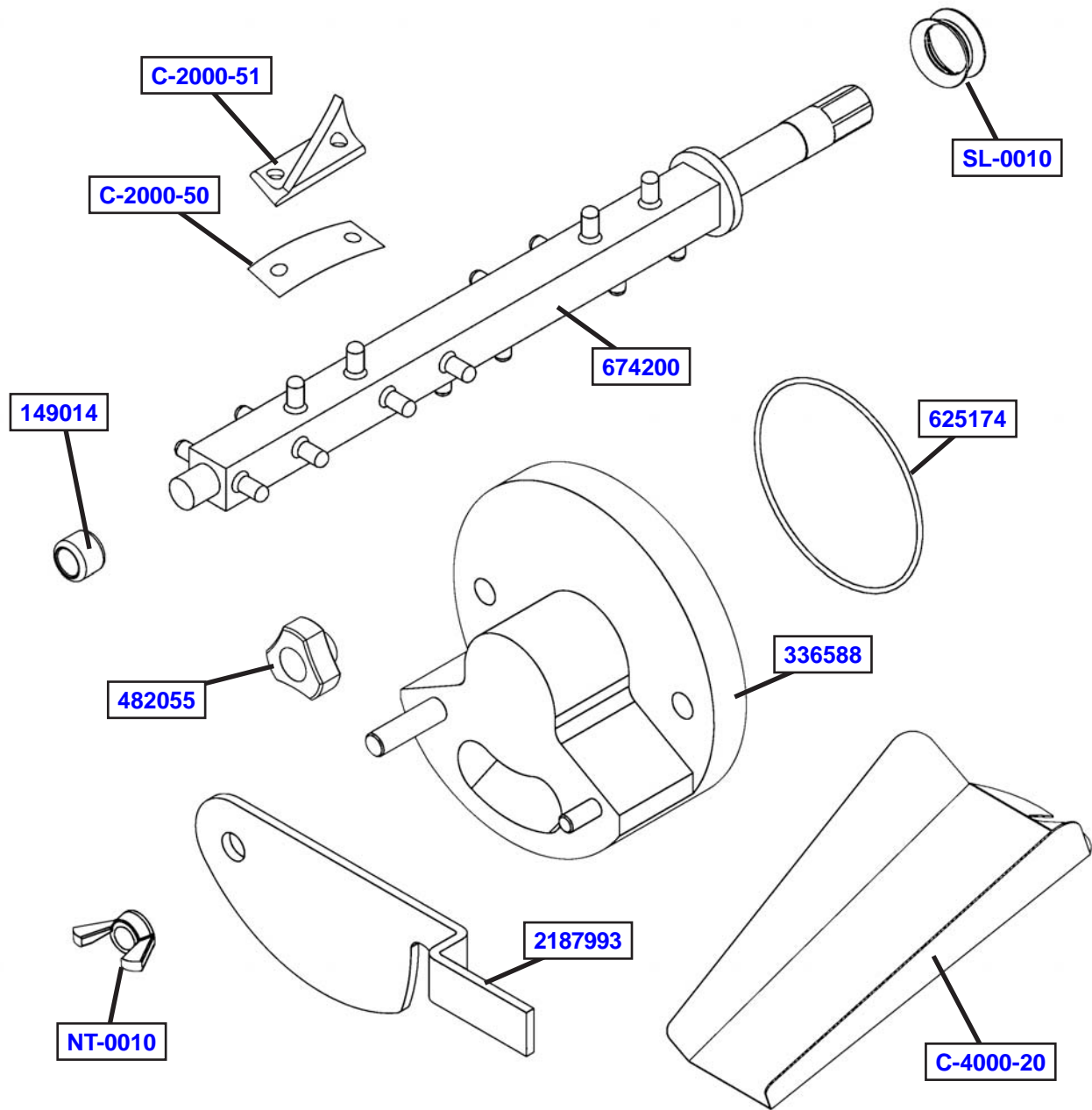

Part Number	Description	Quantity
C-2000-50	Spring	12 per barrel
C-2000-51	Blade (12 per Barrel)	12 per barrel
C-4000-19	Slide - Long (Chute) (14")	1
C-4000-20	Slide - Short (Chute) (10")	1
NT-0010	Wing Nut - Stainless Steel (Front Gate)	1 per barrel
SL-0010	Seal - Beater Shaft (Rear)	1 per barrel
149014	Wearguard - Front Beater Shaft (Small)	1 per barrel
336588	Front Door w/Pins	1 per barrel
482055	Knob - Front Door (Stainless) (3 Point)	2 per barrel
482061	Knob - Front Door (Stainless) (5 Point)	2 per barrel
538397	Hex Nut - Front Gate	1 per barrel
625174	O-Ring - Front Door (Black)	1 per barrel
674200	Beater Shaft	1 per barrel
2187993	Gate - Front	1 per barrel

### 5.3 HOPPER PARTS

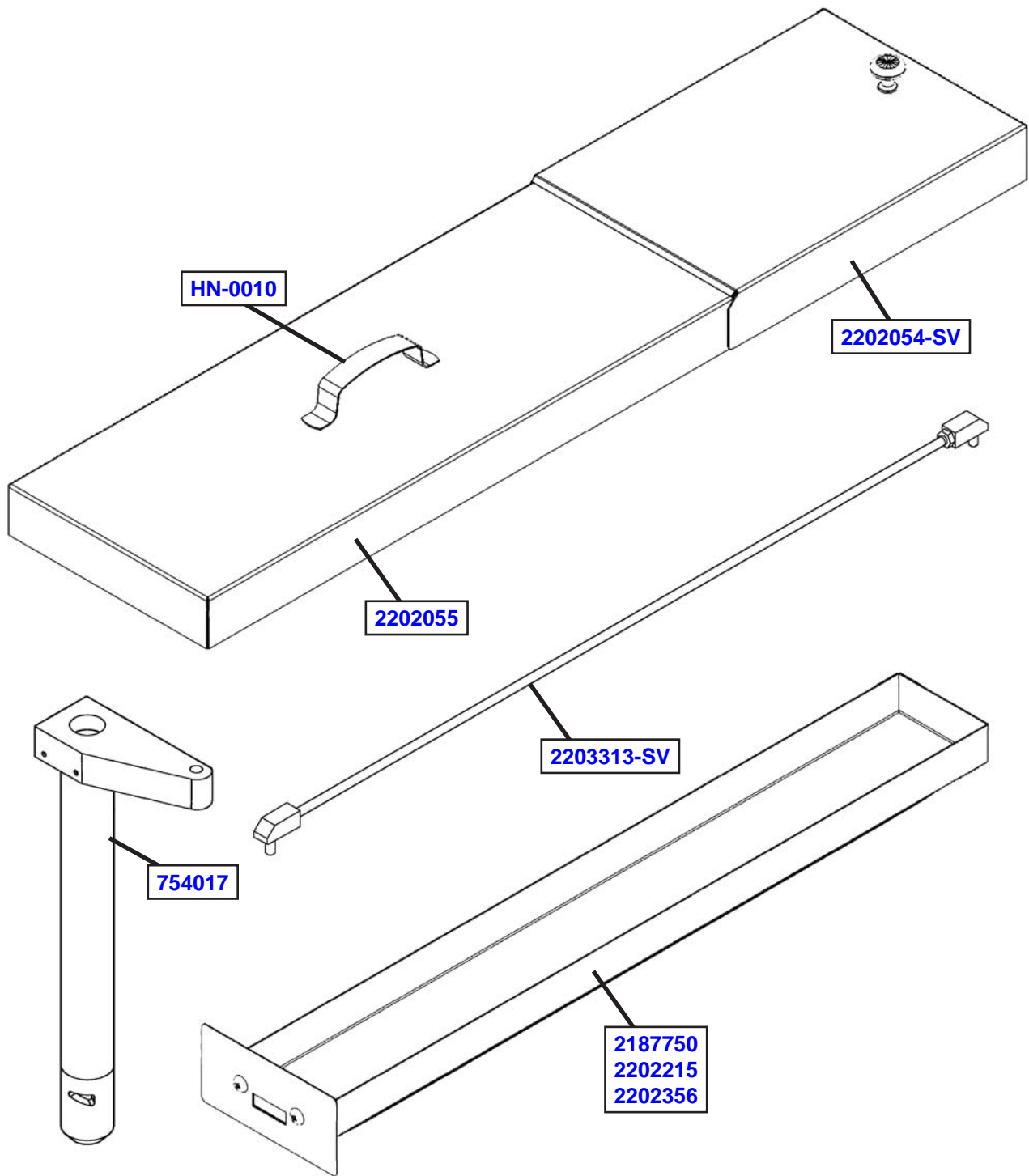

Part Number	Description	Quantity
<a href="#">HN-0010</a>	Handle - Rear Hopper Cover (Requires # <a href="#">647533</a> )	1 per barrel
<a href="#">624645-5</a>	O-Ring - Flow Valve (# <a href="#">754032</a> ) (5 Pack)	-
<a href="#">754017</a>	Flow Valve (No O-Rings)	1 per barrel
<a href="#">2187750</a>	Tray - Drain (CC303)	1
<a href="#">2202054-SV</a>	Cover - Rear Hopper w/Handle	1 per barrel
<a href="#">2202055</a>	Cover - Front Hopper	1 per barrel
<a href="#">2202215</a>	Tray - Drain (CC202)	1
<a href="#">2202356</a>	Tray - Drain (CC404)	1
<a href="#">2203313-SV</a>	Flow Control Rod	1 per barrel

## 5.4 PANELS AND SCREWS

Part	Description	Quantity
<a href="#">647899</a>	Screw - All Panels	-
<a href="#">2187744</a>	Panel - Front Electrical (Culvers CC303) (L.H. Service)	1
<a href="#">2187751</a>	Panel - Drain Tray Cover	1
<a href="#">2187754</a>	Panel - Side Panel Cover	3
<a href="#">2187757</a>	Panel - Rear (CC303)	1
<a href="#">2187785</a>	Panel - Front Lower (CC303)	1
<a href="#">2202208</a>	Panel - Front Electrical (GM CC303)	1
<a href="#">2202213</a>	Panel - Front Electrical (GM CC202)	1
<a href="#">2202216</a>	Panel - Rear (CC202)	1
<a href="#">2202230</a>	Panel - Front Lower (CC202)	1
<a href="#">2202354</a>	Panel - Front Electrical (Culvers CC404)	1
<a href="#">2202357</a>	Panel - Rear (CC404)	1
<a href="#">2202371</a>	Panel - Front Lower (CC404)	1
<a href="#">2202628</a>	Panel - Rear (CC202 Abbott's)	1
<a href="#">2202635</a>	Panel - Upper Side	2
<a href="#">2202636</a>	Panel - Lower Side	2
<a href="#">2203289</a>	Panel - Rear (CC303)	1
<a href="#">2203391</a>	Panel - Front Electrical (Culver's CC303 R.H. Service)	1

## 5.5 FAUCET

Part	Description	Quantity
<a href="#">360003</a>	Extension (#FA-0010 Faucet)	1
<a href="#">369336</a>	Aerator - Swing Faucet	1
<a href="#">369337</a>	Faucet Arm - Swing Style	1
<a href="#">369337-SV</a>	Faucet Arm Kit (Arm & Aerator)	-

## 5.6 ELECTRICAL PANELS

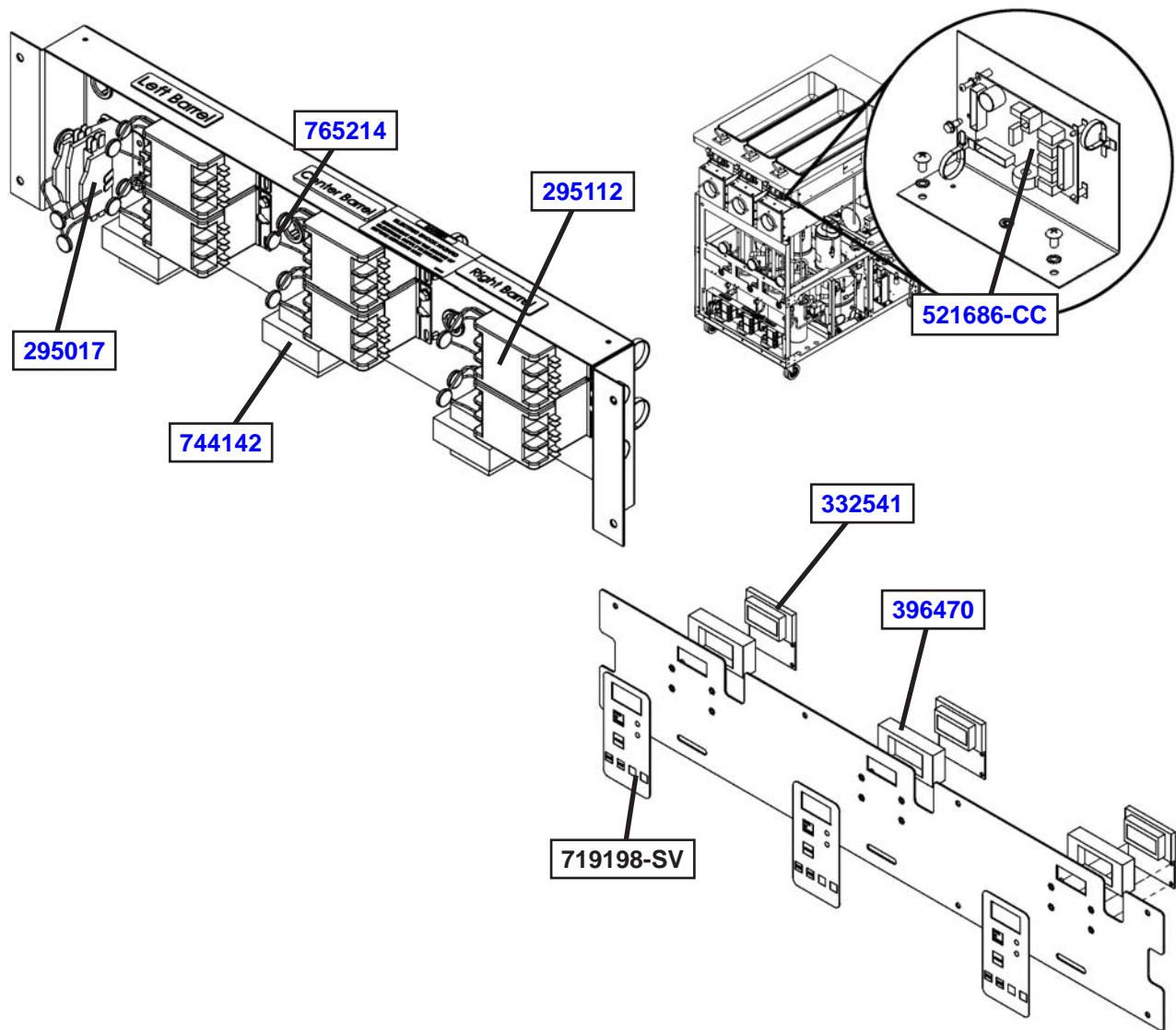

Part	Description	Quantity
<a href="#">229115</a>	Cable - Phone (Control Board To Display Board)	1 per barrel
<a href="#">230622</a>	Capacitor - Start (# <a href="#">522856</a> Motor)	1 per barrel
<a href="#">230653</a>	Capacitor - Run (# <a href="#">282090</a> Compressor)	1 per barrel
<a href="#">231058</a>	Capacitor - Start (# <a href="#">282090</a> Compressor)	1 per barrel
<a href="#">231075</a>	Capacitor - Run (# <a href="#">522856</a> Motor)	1 per barrel
<a href="#">295017</a>	Contactor (45CG20AG) (Hopper Condenser)	1
<a href="#">295112</a>	Contactor - Compressor / Drive	2 per Barrel
<a href="#">332541</a>	Board - Display Module	1 per Barrel
<a href="#">396470</a>	Gasket - Display (1 Per Barrel)	1 per barrel
<a href="#">493042</a>	Flasher - Indicator Light	1
<a href="#">521686-CC</a>	Board - Program (IntelliTec)	1 per barrel
<a href="#">618142</a>	Relay (# <a href="#">282090</a> Compressor) (1 PH)	1 per barrel
<a href="#">618231</a>	Relay - Overload (3 PH)	1 per barrel
<a href="#">719098-SV</a>	Switch - Membrane Strip (Touchpad & Ribbon)	1 per barrel
<a href="#">744142</a>	Transformer	1 per barrel
<a href="#">765214</a>	Varistor Harness	-

## 5.7 RIGHT SIDE VIEW (AIR-REMOTE SHOWN)

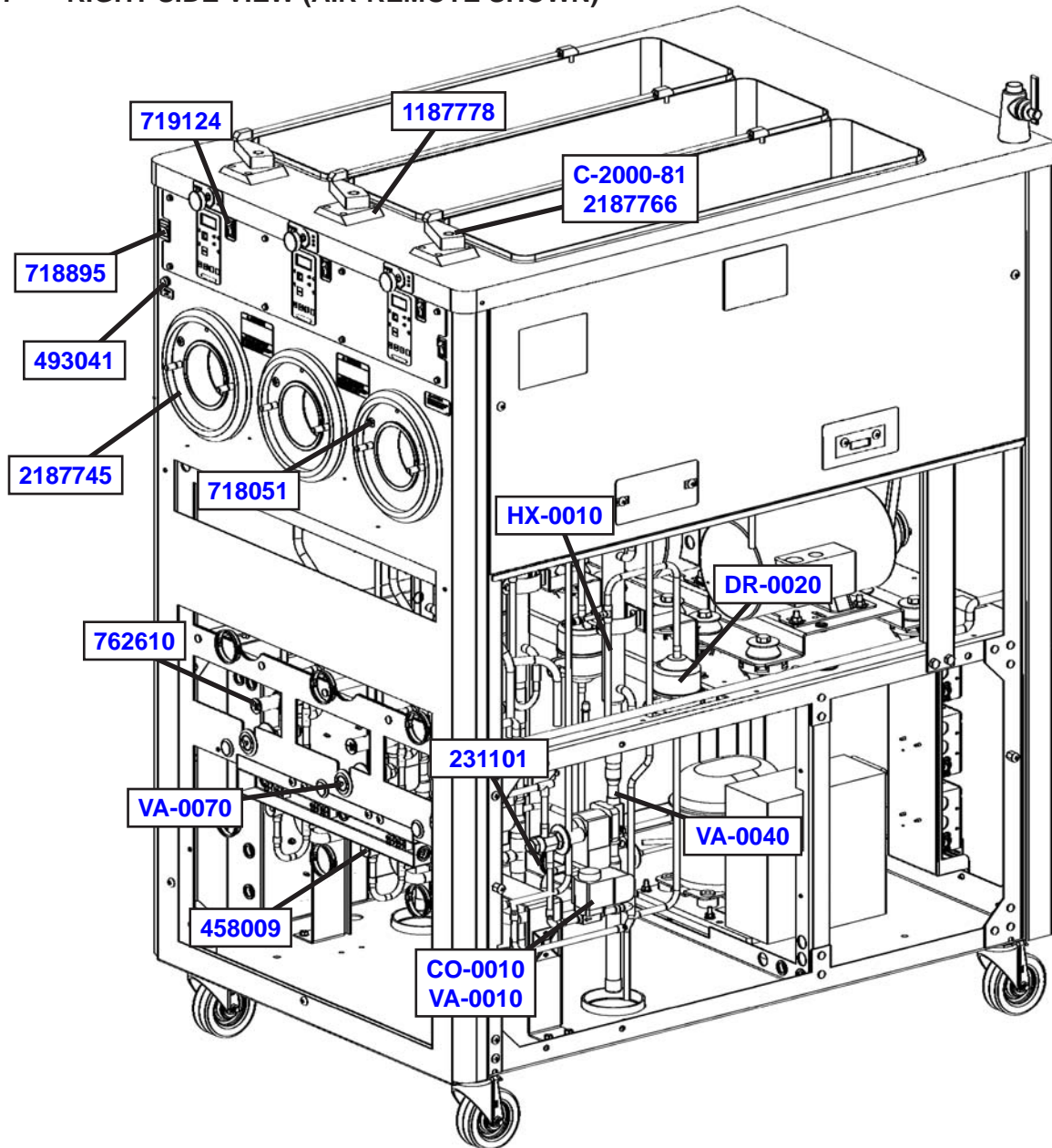

Part	Description	Quantity
C-2000-81	Flow Control Gear Arm	1 per barrel
CO-0010	Valve Coil - Solenoid (240V) (VA-0010) (Barrel)	-
DR-0020	Drier - Filter (3/8" OD) (Cap Tube)	1
HX-0010	Heat Exchanger - 7/8" (Suction Side)	1 per barrel
VA-0010	Valve - Solenoid (3/8")	1
VA-0040	Valve - Solenoid (7/8") (Suction)	1 per barrel
VA-0070	Valve - Expansion (AXV)	1 per barrel + 1
231101	Cap Tube Only	1
458009	Sight Glass	1 per barrel
493041	Indicator Light (Hopper Off)	1
718051	Switch - Reed (Door Interlock)	1 per barrel
718895	Switch - Rocker (Hoppers)	1
719124	Switch - Rocker (Freezing Cylinders / Lemon Ice)	1 per barrel + 1
762610	Valve - ORI (Air Remote)	1 per barrel
1187778	Hopper Cover Stop	1 per barrel
2187745	Trim Ring - Front Barrel	1 per barrel
2187766	Gearbox - Flow Control	1 per barrel

## 5.8 REAR VIEW (WATER-COOLED SHOWN)

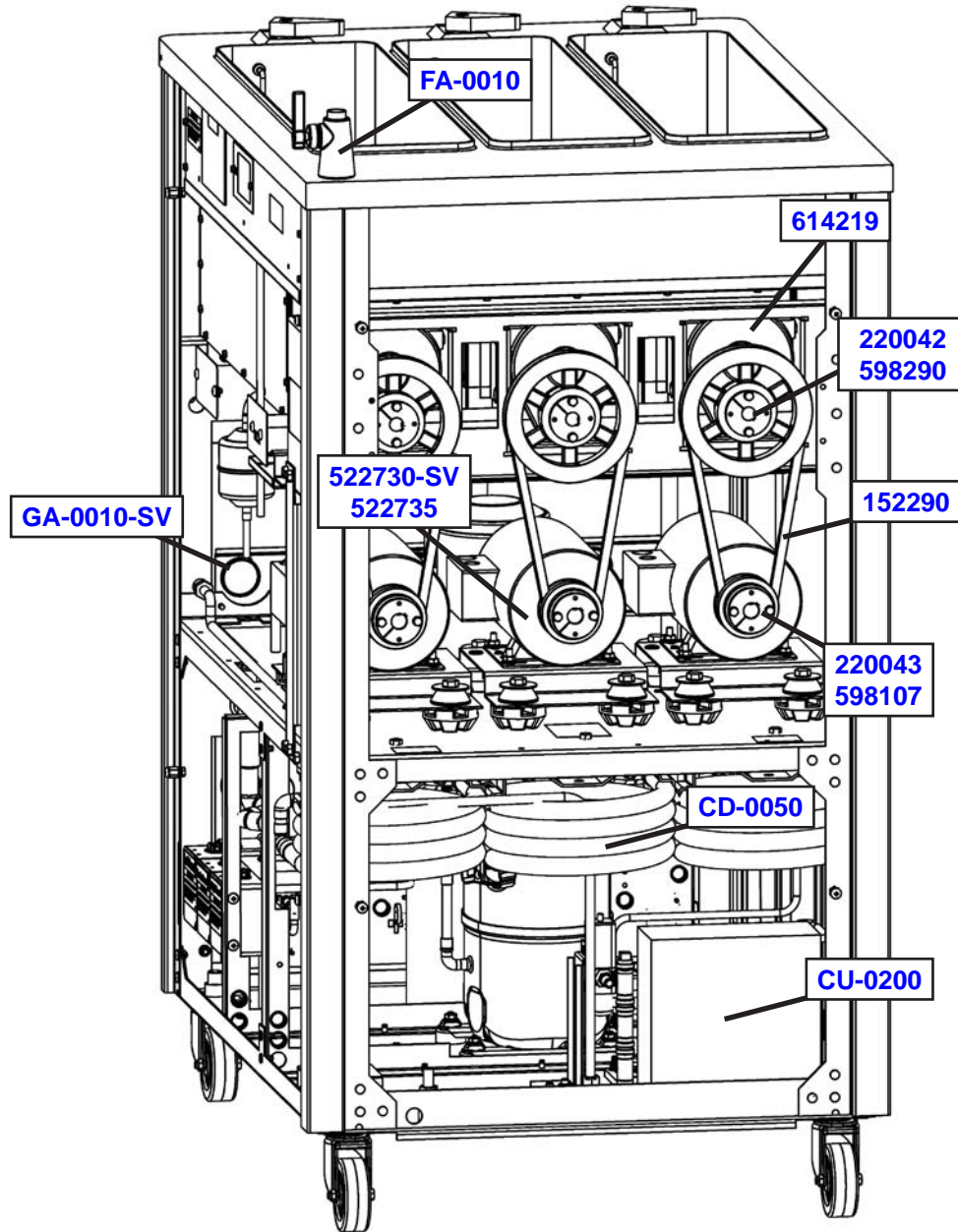

Part	Description	Quantity
CD-0050	Condenser - 2 Ton (Water-Cooled)	1 per barrel
CU-0200	Condensing Unit w/Compressor (Hopper) (60 Hz)	1
CU-0205	Condensing Unit - Hopper (50 Hz)	1
FA-0010	Faucet - Swing-Out	1
GA-0010-SV	Gauge - Barrel Pressure (Suction)	-
152272	Belt - Gripnotch (BX32) (Ser. #31243 - #34299)	1 per barrel
152290	Belt - V (BX36) (Ser. #34300 Plus)	1 per barrel
220042	Bushing - Pulley (Speed Reducer) (#598290 Pulley)	1 per barrel
220043	Bushing (#598107 Pulley)	1 per barrel
285011	Condensing Unit (50 Hz)	1
522730-SV	Motor - Drive w/Base (1 PH & 3 PH) (3 HP)	1 per barrel
522735	Motor - Drive (380V - 415V) (3 PH) (50 Hz)	1 per barrel
598107	Pulley - Drive Motor (Ser. #343004 Plus)	1 per barrel
598290	Pulley - Speed Reducer (Ser. #343004 Plus)	1 per barrel
598577	Pulley - Speed Reducer (Ser. #31243 - #343299)	1 per barrel
598608	Pulley - Drive Motor (Ser. #31243 - #34299)	1 per barrel
614219	Speed Reducer	1 per barrel

## 5.9 LEFT SIDE VIEW (WATER-COOLED SHOWN)

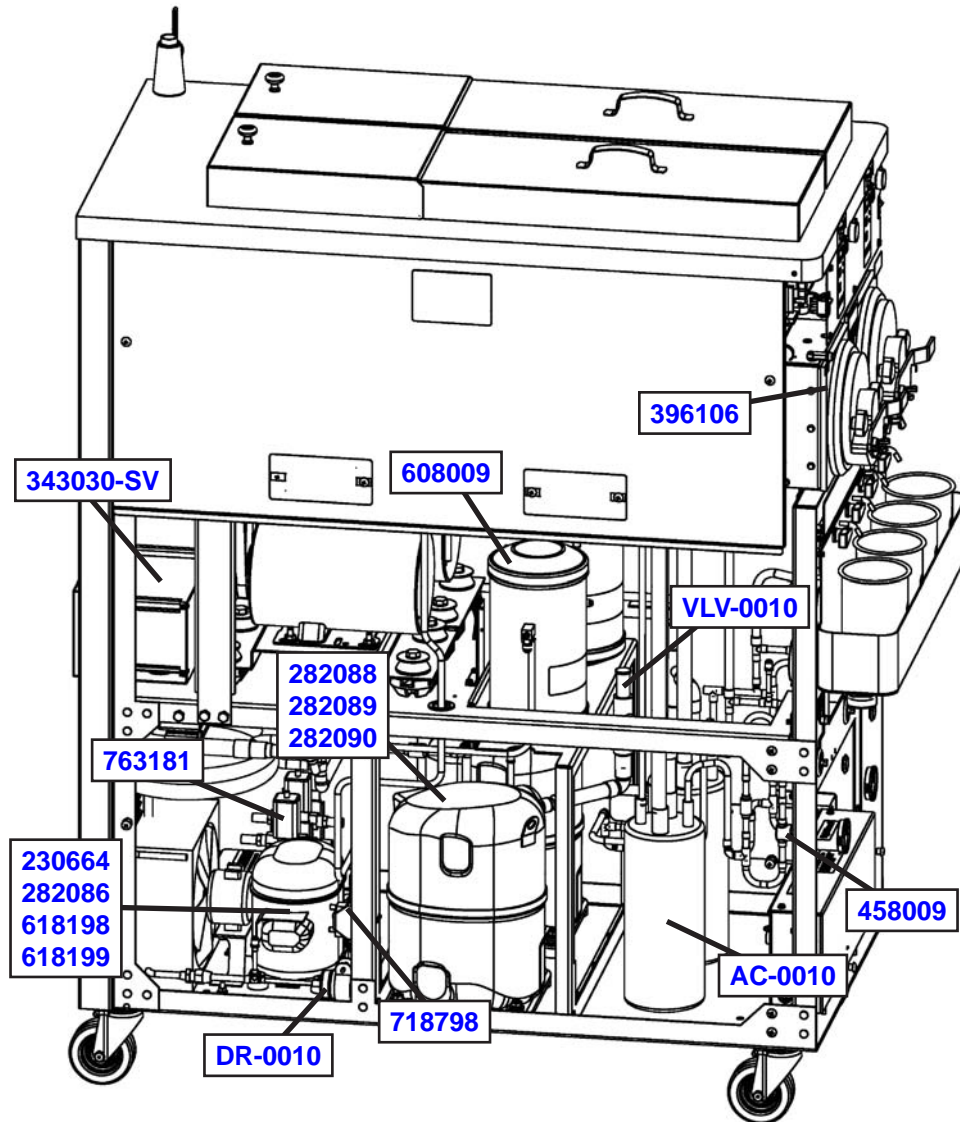

Part	Description	Quantity
AC-0010	Accumulator / Heat Exchanger - 7/8"	1 per barrel
DR-0010	Drier - Filter (1/4" OD)	1
VLV-0010	Valve - Crankcase Pressure Regulator (7/8")	1 per barrel
230664	Capacitor - Start (Hopper Condenser Compressor)	1
282086	Compressor (For CU-0200 Hopper Condenser)	-
282088	Compressor - 3 PH (60 Hz)	1 per barrel
282089	Compressor - 3 PH (380-420V) (50 Hz)	1 per barrel
282090	Compressor - 1 PH (No Capacitors) (60 Hz)	1 per barrel
343030-SV	Drive - Variable Speed (1 PH)	1 per barrel
396106	Gasket - Front Evaporator	1 per barrel
608009	Receiver	1 per barrel
618198	Relay - Current (Hopper Condenser Compressor)	1
618199	Relay - Overload (Hopper Condenser Compressor)	1
718794	Switch - High Pressure Auto Reset (Water-Cooled)	1 per barrel
718798	Switch - High Pressure Cutout	1
763181	Valve - Water	1 per barrel

## 5.10 DIPPING TROUGHS

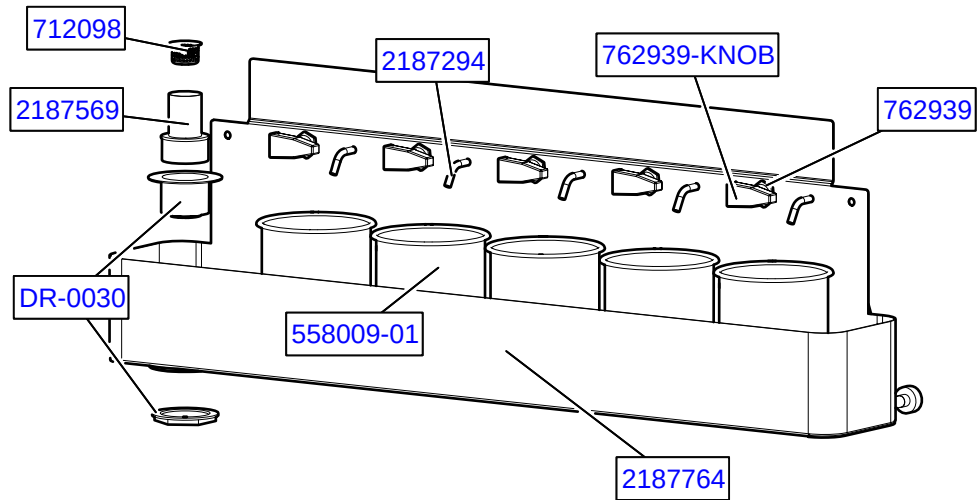

Part	Description	Quantity
DR-0030	Drain (Round Dividers)	1
558009-01	Pot - Round	1 per barrel + 2
712098	Strainer	1
762925	Valve - Needle (Water Supply)	-
762939	Valve Ball (Water Supply)	1 per barrel + 2
762939-KNOB	Knob - Valve Ball (Requires #1171955 Set Screws)	1 per barrel + 2
1171955	Set Screw - Eccentric (Valve Ball Knob)	-
2187294	Spout - Needle Valve	1 per barrel + 2
2187297	Dipping Trough Divider (CC303 L.H. Service)	1
2187535	Dipping Trough Divider (CC404)	1
2187569	Overflow	1
2187763	Dipping Trough Assembly (CC303)	1
2187764	Dipping Trough (CC303 L.H. Service)	1
2187915	Dipping Trough Divider (CC303 R.H. Service)	1
2202063	Dipping Trough Divider (CC202)	1
2202218	Dipping Trough Assembly (CC202)	1
2202219	Dipping Trough (CC202)	1
2202359	Dipping Trough Assembly (CC404)	1
2202360	Dipping Trough (CC404)	1
2203393	Dipping Trough (CC303 R.H. Service)	1





**WARRANTY  
CUSTARD EQUIPMENT AND BATCH EQUIPMENT**

1. **Scope:**  
PW Stoelting, L.L.C. (“Stoelting”) warrants to the first user (the “Buyer”) that the freezing cylinders, hoppers, compressors, drive motors, speed reducers, beaters, and auger shafts of Stoelting custard equipment and batch equipment will be free from defects in materials and workmanship under normal use and proper maintenance appearing within two (2) years, and that all other components of such equipment manufactured by Stoelting will be free from defects in material and workmanship under normal use and proper maintenance appearing within twelve (12) months after the date that such equipment is originally installed.
  
2. **Disclaimer of Other Warranties:**  

**THIS WARRANTY IS EXCLUSIVE; AND STOELTING HEREBY DISCLAIMS ANY IMPLIED WARRANTY OF MERCHANTABILITY OR FITNESS FOR PARTICULAR PURPOSE.**
  
3. **Remedies:**  
Stoelting’s sole obligations, and Buyer’s sole remedies, for any breach of this warranty shall be the repair or (at Stoelting’s option) replacement of the affected component at Stoelting’s plant in Kiel, Wisconsin, or (again, at Stoelting’s option) refund of the purchase price of the affected equipment, and, during the first twelve (12) months of the warranty period, deinstallation/reinstallation of the affected component from/into the equipment. Those obligations/remedies are subject to the conditions that Buyer (a) signs and returns to Stoelting, upon installation, the Start-Up and Training Checklist for the affected equipment, (b) gives Stoelting prompt written notice of any claimed breach of warranty within the applicable warranty period, and (c) delivers the affected equipment to Stoelting or its designated service location, in its original packaging/crating, also within that period. Buyer shall bear the cost and risk of shipping to and from Stoelting’s plant or designated service location.
  
4. **Exclusions and Limitations:**  
This warranty does not extend to parts, sometimes called “wear parts”, which are generally expected to deteriorate and to require replacement as equipment is used, including as examples but not intended to be limited to o-rings, auger seals, auger support bushings, and drive belts. All such parts are sold

**AS IS.**

Further, Stoelting shall not be responsible to provide any remedy under this warranty with respect to any component that fails by reason of negligence, abnormal use, misuse or abuse, use with parts or equipment not manufactured or supplied by Stoelting, or damage in transit.

**THE REMEDIES SET FORTH IN THIS WARRANTY SHALL BE THE SOLE LIABILITY STOELTING AND THE EXCLUSIVE REMEDY OF BUYER WITH RESPECT TO EQUIPMENT SUPPLIED BY STOELTING; AND IN NO EVENT SHALL STOELTING BE LIABLE FOR ANY INCIDENTAL OR CONSEQUENTIAL DAMAGES, WHETHER FOR BREACH OF WARRANTY OR OTHER CONTRACT BREACH, NEGLIGENCE OR OTHER TORT, OR ON ANY STRICT LIABILITY THEORY.**