



Model CF101
SERVICE MANUAL

Manual No. [513644](#)

Mar. 2009

This manual provides basic information about the machine. Instructions and suggestions are given covering its operation and care.

The illustrations and specifications are not binding in detail. We reserve the right to make changes to the machine without notice, and without incurring any obligation to modify or provide new parts for machines built prior to date of change.

DO NOT ATTEMPT to operate the machine until instructions and safety precautions in this manual are read completely and are thoroughly understood. If problems develop or questions arise in connection with installation, operation, or servicing of the machine, contact Stoelting.



stoeltingfoodservice.com

Stoelting Foodservice Equipment
502 Highway 67
Kiel, WI 53042-1600
U.S.A.

Main Tel: 800.558.5807
Fax: 920.894.7029

Customer Service: 888.429.5920
Fax: 800.545.0662
Email: foodservice@stoelting.com

© 2014 PW Stoelting, LLC

A Few Words About Safety

Safety Information

Read and understand the entire manual before operating or maintaining Stoelting equipment.

This manual provides the operator with information for the safe operation and maintenance of Stoelting equipment. As with any machine, there are hazards associated with their operation. For this reason safety is emphasized throughout the manual. To highlight specific safety information, the following safety definitions are provided to assist the reader.

The purpose of safety symbols is to attract your attention to possible dangers. The safety symbols, and their explanations, deserve your careful attention and understanding. The safety warnings do not by themselves eliminate any danger. The instructions or warnings they give are not substitutes for proper accident prevention measures.

If you need to replace a part, use genuine Stoelting parts with the correct part number or an equivalent part. We strongly recommend that you do not use replacement parts of inferior quality.



Safety Alert Symbol:

This symbol Indicates danger, warning or caution. Attention is required in order to avoid serious personal injury. The message that follows the symbol contains important information about safety.

Signal Word:

Signal words are distinctive words used throughout this manual that alert the reader to the existence and relative degree of a hazard.



The signal word "WARNING" indicates a potentially hazardous situation, which, if not avoided, may result in death or serious injury and equipment/property damage.



The signal word "CAUTION" indicates a potentially hazardous situation, which, if not avoided, may result in minor or moderate injury and equipment/property damage.

CAUTION

The signal word "CAUTION" not preceded by the safety alert symbol indicates a potentially hazardous situation, which, if not avoided, may result in equipment/property damage.

NOTE (or NOTICE)

The signal word "NOTICE" indicates information or procedures that relate directly or indirectly to the safety of personnel or equipment/property.

TABLE OF CONTENTS

Section	Description	Page
1	Description and Specifications	
1.1	Description	1
1.2	Specifications	2
2	Installation Instructions	
2.1	Safety Precautions	3
2.2	Shipment and Transit	3
2.3	Machine Installation	3
3	Initial Set-Up and Operation	
3.1	Operator's Safety Precautions	5
3.2	Operating Controls and Indicators	5
3.3	Sanitizing	6
3.4	Freeze Down and Operation	7
3.5	Mix Information	8
3.6	Removing Mix from Machine	8
3.7	Cleaning the Machine	8
3.8	Disassembly of Machine Parts	8
3.9	Cleaning the Machine Parts	9
3.10	Assembly of Machine	9
3.11	Routine Cleaning	10
3.12	Cleaning and Sanitizing Information	10
4	Maintenance and Adjustments	
4.1	Machine Adjustment	13
4.2	Obtaining Readings and Modifying Settings (Service Personnel Only)	13
4.3	Readings (Service Personnel Only)	13
4.4	Settings (Service Personnel Only)	14
4.5	Drive Belt Tension Adjustment	15
4.6	Preventative Maintenance	15
4.7	Extended Storage	16

Section	Description	Page
5	Refrigeration System	
5.1	Refrigeration System	17
5.2	Refrigerant Recovery and Evacuation	17
5.3	Refrigerant Charging	18
5.4	Compressor	19
5.5	Condenser	20
5.6	Evaporator	20
5.7	Valves	20
A.	Thermostatic Expansion Valve (TXV)	20
B.	Check Valve	21
C.	High Pressure Cutout	22
D.	Hot Gas Bypass	22
E.	Evaporator Pressure Regulator (EPR)	23
5.8	Solenoid	23
5.9	Filter Drier	25
5.10	Capillary Tube	25
5.11	Receiver	25
6	Electrical and Mechanical Control Systems	
6.1	IntelliTec Controller	27
6.2	Contactors	27
6.3	Drive Motor	28
6.4	Capacitors	29
6.5	Gearbox	29
6.6	Condenser Fan Motor	30
6.7	Potential Relay	30
6.8	Temperature Control Sensor	30
7	Troubleshooting	
7.1	Error Codes	31
7.2	Troubleshooting Error Codes	31
7.3	Troubleshooting Tables	33
8	Replacement Parts	
8.1	Decals and Lubrication	35
8.2	Panels and Panel Screws	35
8.3	Beater Shaft and Faceplate Parts	36
8.4	Hopper Parts and Trays	37
8.5	Electrical Panel	38
8.6	Front	39
8.7	Rear	40
8.8	Left Side	41
8.9	Wiring Diagram	42

SECTION 1 DESCRIPTION AND SPECIFICATIONS

1.1 DESCRIPTION

The CF101 is a counter top continuous flow custard machine. It is equipped with fully automatic controls to provide a uniform product and features Quick-Freeze technology. This manual is designed to assist qualified service personnel and operators in the installation, operation and maintenance of the CF101 frozen custard machine.



Figure 1-1 Model CF101

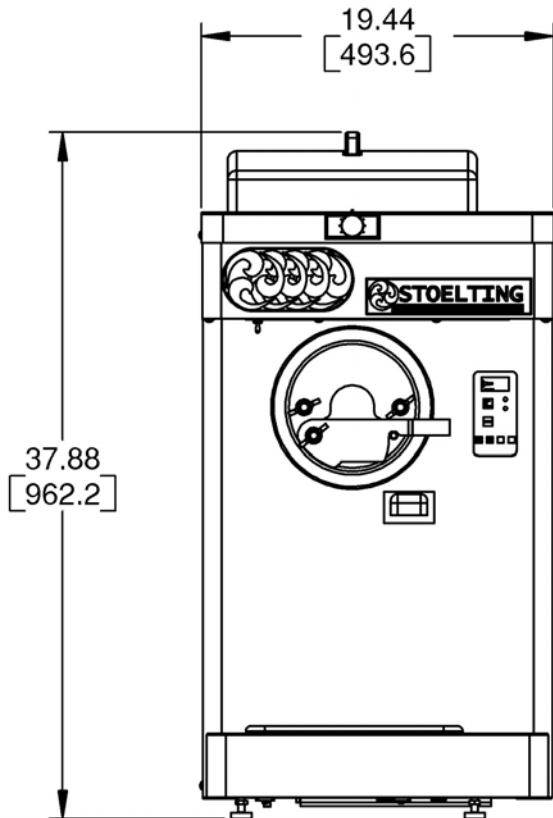

FRONT VIEW

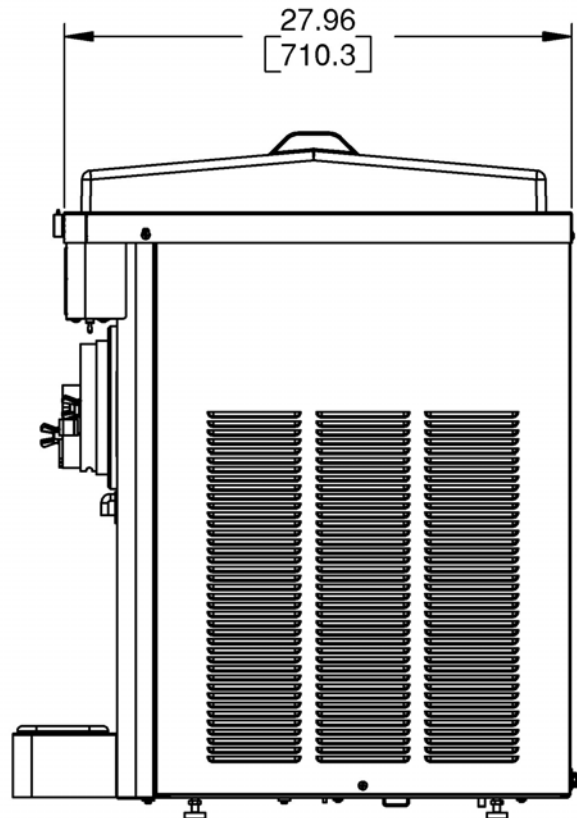

SIDE VIEW

Figure 1-2 Machine Specifications

1.2 SPECIFICATIONS

CF101			
Dimensions	Machine	with crate	
	width	19-1/2" (49,5 cm)	38-3/4" (98,4 cm)
	height	37-3/4" (95,9 cm)	28-3/4" (73,0 cm)
depth	28" (71,1 cm)	43" (109,2 cm)	
Weight	310 lbs (140,6 kg)	380 lbs (172,3 kg)	
Electrical	1 Phase, 208-240 VAC, 60Hz		
connection type	NEMA6-20P power cord provided		
Compressor	14,000 Btu/hr		
Drive Motor	1-1/2 hp		
Air Flow	Air cooled units require 6" (15,2 cm) air space at left and right sides and 10" (25,4) air space above the machine.		
Hopper Volume	5.4 gallon (30,28 liters)		
Freezing Cylinder Volume	0.8 gallon (3.2 quart), 3,03 liters		

CF101	
Refrigerant	R-404A
Charge	No Receiver 64 oz With Receiver 80 oz
Superheat out of Evaporator	8°F
Suction Pressure (at 72°F)	Freezing Cylinder Only 19-20 psig Freezing Cylinder & Hopper 23 psig Hopper Only 14 psig
Discharge Pressure	235-305 psig
Hot Gas Bypass Pressure	14 psig (only hopper running)
EPR Valve	46-48 psig

Menu	Display	Value
Product 1	Cut In T	3 °F
	Cut Out T	-20 °F
Product 2	Cut In T	3 °F
	Cut Out T	-13 °F
	On Time	180 seconds
	Off Time	30 seconds
Standby	Cut In T	35 °F w/Receiver 25 °F w/o Receiver
	Cut Out T	25 °F w/Receiver 15 °F w/o Receiver
	On Time	60 seconds
	Off Time	900 seconds
Storage	HprCutIn	27.5 °F
	HprCtOut	26.5 °F
	Hpr On	100 seconds
	Hpr Off	6 minutes

SECTION 2 INSTALLATION INSTRUCTIONS

2.1 SAFETY PRECAUTIONS

Do not attempt to operate the machine until the safety precautions and operating instructions in this manual are read completely and are thoroughly understood.

Take notice of all warning labels on the machine. The labels have been put there to help maintain a safe working environment. The labels have been designed to withstand washing and cleaning. All labels must remain legible for the life of the machine. Labels should be checked periodically to be sure they can be recognized as warning labels.

If danger, warning or caution labels are needed, indicate the part number, type of label, location of label, and quantity required along with your address and mail to:

STOELTING, INC.
ATTENTION: Customer Service
502 Hwy. 67
Kiel, Wisconsin 53042

2.2 SHIPMENT AND TRANSIT

The machine has been assembled, operated and inspected at the factory. Upon arrival at the final destination, the entire machine must be checked for any damage which may have occurred during transit.

With the method of packaging used, the machine should arrive in excellent condition. **THE CARRIER IS RESPONSIBLE FOR ALL DAMAGE IN TRANSIT, WHETHER VISIBLE OR CONCEALED.** Do not pay the freight bill until the machine has been checked for damage. Have the carrier note any visible damage on the freight bill. If concealed damage and/or shortage is found later, advise the carrier within 10 days and request inspection. The customer must place claim for damages and/or shortages in shipment with the carrier. Stoelting, Inc. cannot make any claims against the carrier.

2.3 MACHINE INSTALLATION

Installation of the machine involves moving the machine close to its permanent location, removing all crating, setting in place, assembling parts, and cleaning.

- A. Uncrate the machine.
- B. Accurate leveling is necessary for correct drainage of the freezing cylinder and to insure correct overrun. Place a bubble level on top of the machine at each corner to check for level condition. If adjustment is necessary, level the machine by turning the bottom part of each leg in or out. Then separate machine base gasket and install with seam to the back and angle to the top.
- C. Correct ventilation is required. The CF101 requires a minimum of 6" (15,2 cm) air space at left and right sides and 10" (25,4) air space above the machine.



Figure 2-2 Space and Ventilation Requirements

CAUTION

Failure to provide adequate ventilation will void warranty.

- D. Place the Main Freezer Power Off/On switch in the Off position.
- E. Connect the power cord to the proper power supply. The plug is designed for 208-240 Volt/20 amp duty. Check the nameplate on your machine for the proper supply. The unit must be connected to a properly grounded receptacle. The electrical cord furnished as part of the machine has a three prong grounding type plug. The use of an extension cord is not recommended, if necessary use one with a size 12 gauge or heavier with ground wire. Do not use an adapter to get around grounding requirement.

WARNING

Do not alter or deform electrical plug in any way. Altering the plug to fit into an outlet of different configuration may cause fire, risk of electrical shock, product damage and will void warranty.

SECTION 3 INITIAL SET-UP AND OPERATION

3.1 OPERATOR'S SAFETY PRECAUTIONS

SAFE OPERATION IS NO ACCIDENT; observe these rules:

- A. Know the machine. Read and understand the Operating Instructions.
- B. Notice all warning labels on the machine.
- C. Wear proper clothing. Avoid loose fitting garments, and remove watches, rings or jewelry that could cause a serious accident.
- D. Maintain a clean work area. Avoid accidents by cleaning up the area and keeping it clean.
- E. Stay alert at all times. Know which switch, push button or control you are about to use and what effect it is going to have.
- F. Disconnect electrical cord for maintenance. Never attempt to repair or perform maintenance on the machine until the main electrical power has been disconnected.
- G. Do not operate under unsafe operating conditions. Never operate the machine if unusual or excessive noise or vibration occurs.

3.2 OPERATING CONTROLS AND INDICATORS

Before operating the machine, it is required that the operator know the function of each operating control. Refer to Figure 3-1 for the location of the operating controls on the machine.



WARNING

High voltage will shock, burn or cause death. The Off/On switch must be placed in the OFF position prior to disassembling for cleaning or servicing. Do not operate machine with cabinet panels removed.

A. Main Freezer Power Off/On Switch

The Main Freezer Power Off/On switch is a two-position toggle switch used to supply power to the control circuit. When the switch is in the Off position, power will not be supplied to the control board or refrigeration system. When the switch is put in the On position, the machine will be in standby mode. The display will read Standby and the amber LED will light.



Figure 3-1 CF101 Controls

B. Product Selector Switch

The product selector switch changes the refrigeration profile to allow two different products to be made. Before the machine is in ready mode, this switch can be moved to the desired profile.

C. PUSH TO FREEZE Button

The PUSH TO FREEZE button is used to initiate the run mode. To start the machine, place the Main Freezer Power Off/On switch in the On position and press the PUSH TO FREEZE button.

D. LEDs

The membrane switch features two lights; a green LED and an amber LED. The green LED will flash when the freezing cylinder is near ready mode and stay lit during ready mode. The amber LED is lit during standby, purge and clean modes.

NOTE

If the machine enters an error condition, alternating green and amber lights will flash. The LCD will display an error. Turn the Main Freezer Power Off/On switch to the OFF position, correct the problem (Refer to Troubleshooting in Section 4) and turn the machine back on.

E. PURGE/CLEAN Button

PURGE Mode - When the PURGE/CLEAN button is pressed, the beater shaft will rotate. A PURGE message will display on the screen along with a 5 minute timer. Hopper refrigeration will continue to run. When the timer gets to 0:00 and no other buttons are pressed, the machine will go into standby mode.

CLEAN Mode - During PURGE mode, if the PURGE/CLEAN button is pressed and held for 3 seconds, the CLEAN mode will begin. The beater shaft will continue to rotate and hopper refrigeration will stop.

F. Mix Low Light Indicator

The MIX LOW message will appear on the LCD display when there is approximately one gallon of mix left in the hopper. When the MIX LOW message is displayed, refill hopper immediately.

NOTE

Failure to refill hopper immediately may result in operational problems.

G. Menu Navigation Buttons

The Menu Navigation Buttons are primarily used for machine calibration.

Selection Button (SEL) The SEL button is not functional in the normal operation mode. This button is only used by service technicians for machine calibration.

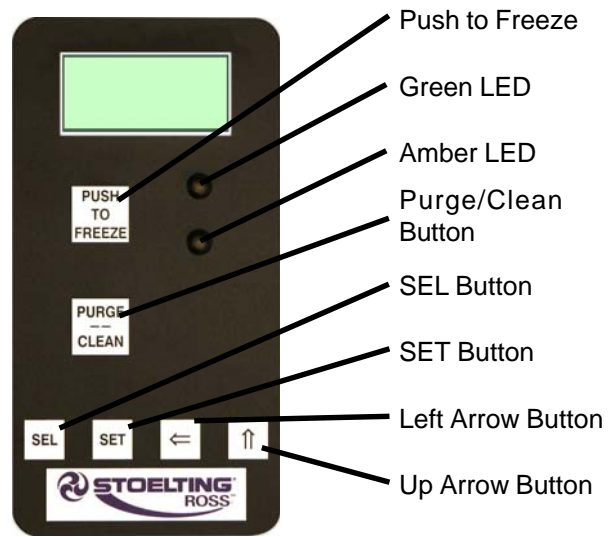

Figure 3-2 IntelliTec Control

Set Button (SET) The SET button is not functional in the normal operation mode. This button is only used by service technicians for machine calibration.

Left Arrow Button (⇐) Pressing any button on the control panel will automatically illuminate the display. The backlight will turn off several seconds after use. To keep the display constantly lit, press and hold the left (⇐) button for five seconds. The backlight function can be reset to normal operation in the same manner.

Up Arrow Button (↑) The ↑ button is not functional in the normal operation mode. This button is only used by service technicians for machine calibration.

H. Front Door Safety Switch

The front door safety switch prevents the beater shaft from turning when the front door is removed. The switch is open when the door is not in place and closed when the door is properly installed.

3.3 SANITIZING

Sanitizing must be done after the machine is cleaned and just before the hopper is filled with mix. Sanitizing the night before is not effective. However, you should always clean the machine and parts after each use.

THE UNITED STATES DEPARTMENT OF AGRICULTURE AND THE FOOD AND DRUG ADMINISTRATION REQUIRE THAT ALL CLEANING AND SANITIZING SOLUTIONS USED WITH FOOD PROCESSING EQUIPMENT BE CERTIFIED FOR THIS USE.

When sanitizing the machine, refer to local sanitary regulations for applicable codes and recommended sanitizing products and procedures. The frequency of sanitizing must comply with local health regulations.

Mix sanitizer according to manufacturer's instructions to provide a 100 parts per million strength solution. Mix sanitizer in quantities of no less than 2 gallons (7.5 liters) of 90° to 110°F (32° to 43°C) water. Allow sanitizer to contact the surfaces to be sanitized for 5 minutes. Any sanitizer must be used only in accordance with the manufacturer's instructions.

In general, sanitizing may be conducted as follows:

- A. Prepare Stera-Sheen Green Label Sanitizer or equivalent according to manufacturer's instructions to provide a 100ppm strength solution. Mix the sanitizer in quantities of no less than 2 gallons of 90° to 110°F (32° to 43°C) water. Any sanitizer must be used only in accordance with the manufacturer's instructions.
- B. Place the tapered end of the flow valve into the hopper drain hole with the arm pointing towards the left. Connect the flow control rod to the flow valve and the flow valve arm (Fig. 3-3).



Figure 3-3 Flow Control Assembly

- C. Make sure the flow control valve is shut by turning the control knob counterclockwise to the 12:00 position.
- D. Place a bucket under the slide.
- E. Pour the sanitizer into the hopper.

NOTE

A small amount of sanitizer may drain into the bucket with the flow control shut.

- F. Place the Main Freezer Power Off/On switch in the On position and press the PURGE/CLEAN button. The display will read PURGE.
- G. Press and hold the PURGE/CLEAN button for 3 seconds. The display will read CLEAN and a 20 minute timer will start.
- G. Turn the flow control knob fully open (clockwise).
- H. Clean sides of hopper, flow valve and underside of hopper cover using a sanitized soft bristle brush dipped in the sanitizing solution.

- I. When the sanitizer has drained from the hopper, press and hold the PURGE/CLEAN button for 3 seconds to stop the beater shaft. Allow the freezing cylinder to drain completely.
- J. Shut off the flow control valve by turning the flow control knob counterclockwise to the 12:00 position.

3.4 FREEZE DOWN AND OPERATION

This section covers the recommended operating procedures to be followed for the safe operation of the machine.

- A. Sanitize just prior to use.

NOTE

Make sure the flow control assembly is in place before adding mix and that the flow control knob is set to the 12:00 position.

- B. Fill hopper with approximately 3 gallons (11.4 liters) of pre-chilled (40°F or 4°C) mix.
- E. Place the Main Freezer Power Off/On switch in the On position. The display will read STANDBY MODE.
- F. Press the PUSH TO FREEZE button. The display will read CUSTARD and a bar on the second line will start to fill. For PRODUCT 2, move the product selector switch to the PRODUCT 2 position.

NOTE

The product selector switch can be changed until the READY message is displayed on the second line.

- G. When the display reads CUSTARD READY, the freezing cylinder is at the correct temperature (Fig. 3-4).
- H. Open the front gate.
- I. Turn the flow control knob clockwise to the 6:00

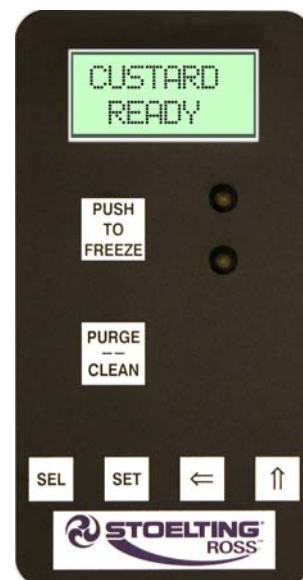

Figure 3-4 Custard Mode

position. A small amount of mix and remaining sanitizer will drain from the machine.

- J. Turn the flow control knob between the 1:00-2:00 position for vanilla or between the 5:00-6:00 for chocolate. After a few minutes, a ribbon of product starts to form.
- K. Adjust the flow control knob until the product flow fills the faceplate outlet and is at the desired texture (Fig. 3-5). The flow control knob setting will be different for each type of product.

NOTE

Adjustments take up to 1 minute before a noticeable difference is seen in the product.

NOTE

A high-pitched noise from the freezing cylinder is an indication that there is not enough mix entering the freezing cylinder. Slowly turn the flow control knob clockwise to increase the flow. It can take up to 1 minute for the adjustment to stop the noise.



Figure 3-5 Proper Flow

3.5 MIX INFORMATION

Mix can vary considerably from one manufacturer to another. Differences in the amount of butterfat content and the quantity and quality of other ingredients have a direct bearing on the finished frozen product. A change in machine performance that cannot be explained by a technical problem may be related to the mix.

Proper product serving temperature varies from one manufacturer's mix to another. When checking the temperature, stir the thermometer in the frozen product to read the true temperature.

Old mix or mix that has been stored at elevated temperatures will produce poor-quality product with a bad taste and unacceptable appearance. To retard bacteria growth in dairy based mixes, the best storage temperature range is between 36° to 40°F (2.2° to 4.4°C).

3.6 REMOVING MIX FROM MACHINE

To remove the mix from the machine, refer to the following steps. Make sure the gate on the faceplate is open.

- A. Press the PURGE/CLEAN button. The display will read PURGE.
- B. Press and hold the PURGE/CLEAN button for 3 seconds. The display will read CLEAN and a 20 minute timer will start.
- C. Open the flow control valve fully by turning the flow control knob clockwise until the pointer is near the 12:00 position.
- D. After the hopper and freezing cylinder have drained, place the Main Freezer Power Off/On switch in the OFF position.

3.7 CLEANING THE MACHINE

NOTE

The frequency of cleaning the machine and machine parts must comply with local health regulations.

After the mix has been removed from the machine, the machine must be cleaned. To clean the machine, refer to the following steps:

- A. Place a container under the slide of the faceplate. Fill the hopper with 2 gallons (7.5 liters) of tap water.
- B. Place the Main Freezer Power Off/On switch in the On position. Press the PURGE/CLEAN button. The display will read PURGE.
- C. Press and hold the PURGE/CLEAN button for 3 seconds. The display will read CLEAN and a 20 minute timer will start.
- D. When the water has drained, place the switch in the OFF position. Allow the freezing cylinder to drain completely.
- E. Prepare detergent water by mixing 2 oz. of Palmolive detergent or equivalent in 2 gallons of 90° to 110°F (32° to 43°C) water. Repeat steps A through D using the detergent solution.

3.8 DISASSEMBLY OF MACHINE PARTS

Inspection for worn or broken parts should be made each time the machine is disassembled. All worn or broken parts should be replaced to ensure safety to both the operator and the customer and to maintain good machine performance and a quality product. Frequency of cleaning must comply with local health regulations.

To disassemble the machine, refer to the following steps:

CAUTION

Hazardous Moving Parts

A revolving beater shaft can grab and cause injury. Place the Main Freezer Power Off/On switch in the OFF position before disassembling for cleaning or servicing.

- A. Remove the flow control rod and flow control valve from the hopper by pulling straight up.
- C. Remove the slide from the faceplate and remove the faceplate.
- D. Remove the beater shaft wearguard.
- F. Remove the beater shaft assembly from the machine. Pull the beater shaft out of the freezing cylinder slowly. As it is being pulled out, carefully remove each of the blades and springs.
- G. Remove the seal from the back of the beater shaft.
- I. Wipe socket lubricant from the drive end (rear) of the beater shaft with a cloth or paper towel.

3.9 CLEANING THE MACHINE PARTS

Place all loose parts in a pan or container and take to the wash sink for cleaning. To clean the parts refer to the following steps:

- A. Prepare detergent water by mixing 2 oz. of Palmolive detergent or equivalent in 2 gallons of 90° to 110°F (32° to 43°C) water.
- B. Place all parts in detergent solution and clean with the provided brushes.
- C. Wash the hopper and freezing cylinder with the detergent water and brushes provided.
- D. Wash the inside of the freezing cylinder with the detergent water.
- E. Rinse all parts with clean 90° to 110°F (32° to 43°C) water.

NOTE

If the machine is not going to be immediately operated, store the faceplate in a clean and sanitized container in a cooler.

3.10 ASSEMBLY OF MACHINE

To assemble the machine parts, refer to the following steps:

NOTE

Petrol Gel sanitary lubricant or equivalent must be used when lubrication of parts is specified.

NOTE

The United States Department of Agriculture and the Food and Drug Administration require that lubricants used on food processing equipment be certified for this use. Use lubricants only in accordance with the manufacturer's instructions.

- A. Coat the rear seal with a generous amount of Petrol Gel.
- B. Install the rear seal onto the beater shaft.
- C. Lubricate the drive (rear) end of the beater shaft with a small amount of white socket lubricant. A small container of socket lubricant is shipped with the machine.
- D. Install two of the springs and blades onto the rear of the beater shaft and insert the shaft part way into freezing cylinder. Rotate the shaft so another spring and blade can be placed onto it.



Figure 3-6 Installing Blades

- E. Install the remaining blades, push the beater shaft into the freezing cylinder and rotate it slowly until the shaft engages the drive coupling.(Fig. 3-6).



Figure 3-7 Install Front Wear Bushing

- F. Lubricate the inside and outside of the wearguard and install it onto the beater shaft (Fig. 3-7).



Figure 3-8 Install Faceplate

- G. Install the large o-ring onto the front plate and install the faceplate onto the machine (Fig. 3-8).
- H. Install slide, hopper cover and drain tray.

3.11 ROUTINE CLEANING

To remove spilled or dried mix from the machine exterior, wash in the direction of the finish with warm soapy water and wipe dry. Do not use highly abrasive materials, as they will mar the finish.

3.12 CLEANING AND SANITIZING INFORMATION

Special consideration is required when it comes to food safety and proper cleaning and sanitizing.

The following information has been compiled by Purdy Products Company, makers of Stera-Sheen Green Label Cleaner/Sanitizer and specifically covers issues for cleaning and sanitizing frozen dessert machines. This information is meant to supplement a comprehensive food safety program.

SOIL MATERIALS ASSOCIATED WITH FROZEN DESSERT MACHINES

MILKFAT/BUTTERFAT – As components of ice-cream/frozen custard mix, these soils will accumulate on the interior surfaces of the machine and its parts. Fats are difficult to remove and help attribute to milkstone buildup.

MILKSTONE – Is a white/gray film that forms on equipment and utensils that come in contact with dairy products. These films will accumulate slowly on surfaces because of ineffective cleaning, use of hard water, or both. Milkstone is usually a porous deposit, which will harbor microbial contaminants and eventually defy sanitizing efforts.

Once milkstone has formed, it is very difficult to remove. Without using the correct product and procedure, it is nearly impossible to remove a thick layer of milkstone. (NOTE: general-purpose cleaners DO NOT remove milkstone.) This can lead to high bacteria counts and a food safety dilemma.

IT IS BEST TO CONTROL MILKSTONE ON A DAILY BASIS BEFORE IT CAN BECOME A SIGNIFICANT FOOD SAFETY PROBLEM.

In addition to food safety, milkstone can cause premature wear to machine parts which can add to costs for replacement parts or possibly more expensive repairs if worn machine parts are not replaced once they have become excessively worn.

IMPORTANT DIFFERENCES BETWEEN CLEANING AND SANITIZING

CLEANING vs. SANITIZING

It is important to distinguish between cleaning and sanitizing. Although these terms may sound synonymous, they are not. BOTH are required for adequate food safety and proper machine maintenance.

CLEANING

- Is the removal of soil materials from a surface.
- Is a prerequisite for effective sanitizing.

NOTE

An UNCLEAN surface will harbor bacteria that can defy sanitizing efforts.

Bacteria can develop and resist sanitizing efforts within a layer of soil material (milkstone). Thorough cleaning procedures that involve milkstone removal are critical for operators of frozen dessert machines.

SANITIZING

- Kills bacteria.
- Can be effective on clean surfaces only.

NOTE

Using a SANITIZER on an unclean surface will not guarantee a clean and safe frozen dessert machine.

PROPER DAILY MAINTENANCE: THE ONLY WAY TO ASSURE FOOD SAFETY AND PRODUCT QUALITY

Proper daily maintenance can involve a wide variety of products and procedures. Overall, the products and procedures fall into three separate categories. (Please note that this is a brief overview intended for informational purposes only.)

1. **CLEANING** – This involves draining mix from the freezing cylinder and rinsing the machine with water. Next, a cleaner is run through the machine. Then, the machine is disassembled and removable parts are taken to the sink for cleaning.
2. **MILKSTONE REMOVAL** – Since almost all cleaners do not have the ability to remove milkstone, the use of a delimer becomes necessary. Although this procedure may not be needed on a daily basis, it will usually follow the cleaning procedure. It requires letting a delimer

solution soak in the machine for an extended period. Individual parts are also soaked in a deliming solution for an extended period (more about delimers in Additional Information).

3. **SANITIZING** – After the machine has been cleaned and contains no milkstone, the machine is reassembled. Then a FDA-approved sanitizing solution is run through the machine to kill bacteria. The machine is then ready for food preparation.

As a recommended cleaner and sanitizer for your frozen dessert machine, STERA-SHEEN has proven to be one of the best daily maintenance products for:

- **CLEANING** – Thorough removal of all solids including butterfat and milk fat.
- **MILKSTONE REMOVAL** – Complete removal of milkstone.
- **SANITIZING** – FDA-approved no rinse sanitizer for food contact surfaces.

ADDITIONAL INFORMATION

THE USE OF DELIMERS

A delimer is a strong acid that has the ability to dissolve milkstone. This type of chemical may become necessary once high levels of milkstone have developed. While these products are very effective for removing HIGH levels of milkstone, they are not ideal for two reasons:

1. **PRODUCT SAFETY** – Strong acids are dangerous chemicals and handling them requires safety
2. **MACHINE DAMAGE** – Strong acids will attack metal and rubber causing premature wear of parts. The use of a delimer needs to be closely monitored to avoid damage to machine surfaces and parts.

With proper daily use of STERA-SHEEN or its equivalent, there is no need for the use of a DELIMER.

DO NOT USE BLEACH

- **BLEACH HAS ABSOLUTELY NO CLEANING PROPERTIES.**
- **BLEACH IS CORROSIVE.** It can and will damage components of the machine causing premature wear and metal corrosion.

GENERAL PURPOSE CLEANERS

General purpose cleaners do not have the ability to remove milkstone. Milkstone will become a problem if not remedied with additional products and procedures.

THE USE OF CHLORINE TEST STRIPS

“Test strips” are used to determine concentrations of active chlorine in sanitizing solutions. To use the strips, tear off a small portion and submerge it into the sanitizing solution. Then, compare the color change to the color key on the side of the test strip dispenser to determine the approximate chlorine concentration.

The ideal concentration of chlorine needs to be 100 ppm (as stated by the FDA).

NOTE

Follow the directions on the container for proper concentration.

There are two main factors that contribute to falling chlorine concentrations in a sanitizing solution.

1. **PRODUCT USE** – As the chlorine in the solution is being used, chlorine concentrations fall.
2. **TIME** – As time passes, small amounts of chlorine “evaporate” from the solution. (That is why you can smell it.)

Sanitizing solutions should not be allowed to fall below 100 ppm chlorine. New solutions should be mixed once old solutions become ineffective.

SECTION 4 MAINTENANCE AND ADJUSTMENTS

4.1 MACHINE ADJUSTMENT

This section is intended to provide maintenance personnel with a general understanding of the machine adjustments. It is recommended that any adjustments in this section be made by a qualified person.

4.2 OBTAINING READINGS AND MODIFYING SETTINGS (SERVICE PERSONNEL ONLY)

Readings and Settings on the IntelliTec control are accessed through the IntelliTec control menu settings. Locating the readings and settings are done using the up arrow (↑) and left arrow (←) buttons on the membrane switch. A printed IntelliTec Menu Settings sheet is located in the information pouch behind the header panel.

IntelliTec Control Readings

To obtain machine readings, locate the value on the machine's menu settings sheet and follow the steps below.

- A. Press and hold the SEL button for 8 seconds. While still holding the SEL button, press the up arrow button (↑). The LCD screen will read DISPLAY.
- B. Release both buttons.
- C. Press the up arrow button (↑) to navigate to the correct reading under DISPLAY or press the left arrow (←) button to navigate to the ERRCODES menu.
- D. Press the up arrow (↑) and left arrow (←) buttons to navigate through the rest of the readings as needed.
- E. When all readings have been obtained, press the up arrow button (↑) from ExitMenu to return to the current mode display.



Figure 4-1 Membrane Switch

Modifying Control Settings

To change the value of a setting, locate it on the IntelliTec Menu Settings sheet and follow the steps below.

IMPORTANT:

Before making changes to any settings, record the original values. If the setting changes do not achieve desired results, return settings to their original values.

- A. Press and hold the SEL button for 8 seconds. While still holding the SEL button, press the up arrow button (↑). The LCD Screen will read DISPLAY.
- B. Release both buttons.
- C. Press the left arrow button (←) to get to the correct menu (Product1, Product 2, Stand By, Storage).
- D. Press the up arrow button (↑) to navigate to the value that needs to be changed.
- E. Press the SET button to enter the edit mode.
- F. Press the up arrow button (↑) to change the setting.
- G. Press the SET button to save the setting and exit the edit mode.
- H. Press the up arrow (↑) and the left arrow (←) buttons to navigate through the rest of the settings as needed.
- I. When all changes have been completed, press the up arrow button (↑) from ExitMenu to return to the current mode display.

4.3 READINGS (SERVICE PERSONNEL ONLY)

The IntelliTec control continuously monitors and records temperatures, voltages, amps, and error code details. Each reading is beneficial to service personnel when troubleshooting.

DISPLAY READINGS

Following are the readings available under the DISPLAY menu:

Hopper

The temperature of the hopper is constantly monitored by the IntelliTec control.

°F and amps

Suction line temperature on the freezing cylinder and drive motor amps are available on the same screen to assist with setup and troubleshooting.

Aux. Temp (°F)

This reading provides the ambient temperature around the IntelliTec control board.

Supply V (VAC)

The input voltage is recorded.

ERROR CODE READINGS

The following details are recorded under the ERRCODES menu for each of the last 25 error codes received:

Err1 (hours)

A timer begins when an error occurs. The timer records the number of hours since the error occurred. If power to the machine is interrupted, the timer will stop until power has been restored.

°F and amps

The suction gas temperature on the freezing cylinder and the drive motor amps are recorded at the time of the error.

Aux. Temp (°F)

Ambient temperature of the IntelliTec control board is recorded at the time of the error.

Str (°F)

The storage temperature is recorded at the time of the error.

VAC and Mode

The input voltage and mode at which the error occurred are recorded. See the table below for descriptions of each mode (Fig. 4-2).

Up Time (hours)

This value is a record of the total time the machine has been in service. If power is interrupted, the timer will stop until power is restored. This timer does not reset.

4.4 SETTINGS (SERVICE PERSONNEL ONLY)

Changing any setting on the IntelliTec control will alter machine operation and affect the product temperature, consistency, or life. Refer to the IntelliTec Menu Settings sheet located in the information pouch behind the header panel of the machine. If any of the following settings on the IntelliTec control differ from the settings sheet, it is recommended to return those settings to factory defaults.

PRODUCT1 AND PRODUCT2 MENUS:

Cut In T (°F)

This setting determines when refrigeration will start during Run Mode.

Cut Out T (°F)

This setting determines when refrigeration stops during Run Mode.

Product 1 / Product 2

This text is shown on the top line after the Push To Freeze button is pressed. The default value is "CUSTARD" for Product 1 and "PRODUCT2" for Product 2.

On Time (sec)

In case of a temperature sensor failure, this setting determines the length of a refrigeration cycle.

Off Time (sec)

In case of a temperature sensor failure, this setting determines the amount of time between refrigeration cycles.

Code	Description	Compressor	Drive Motor	Details
1	Start-Up	Off	Off	
2	Standby	Off	Off	Waiting for a Cycle
3	Standby	Off	Off	
4	Standby	On	Off	
5	Standby	Off	Off	Sensor Fail
6	Standby	On	Off	Sensor Fail
7	Freeze Down	On	Off	Product 1
8	Run Mode	On	On	Product 1
9	Run Mode	Off	On	Product 1
10	Freeze Down	On	Off	Product 2
11	Run Mode	On	On	Product 2
12	Run Mode	Off	On	Product 2
13	Sensor Fail	On	On	Product 1
14	Sensor Fail	On	On	Product 2
15	Sensor Fail	Off	On	Product 2
16	Purge Mode	Hopper Only	On	
17	Clean Mode	Off	Off	
18	High Pressure Cutout	Off	Off	
19	Door Safety Switch Triggered	Off	Off	

Figure 4-2 Modes When Error Occurs

STAND BY MENU:

Cut In T (°F)

This setting determines when refrigeration will start during Stand By Mode.

Cut Out T (°F)

This setting determines when refrigeration stops during Stand By Mode.

On Time (sec)

In case of a temperature sensor failure, this setting determines the length of a refrigeration cycle.

Off Time (sec)

In case of a temperature sensor failure, this setting determines the amount of time between refrigeration cycles.

STORAGE MENU:

Refriger

This setting changes how the control handles the storage refrigeration cycle. The setting is Hopper and should not be changed.

HprCutIn (°F)

This setting determines the temperature at which the hopper refrigeration cycle starts.

HprCtOut (°F)

This setting determines the temperature at which the hopper refrigeration cycle stops.

Hpr On

In case of a temperature sensor failure, this setting determines the length of a refrigeration cycle.

Hpr Off

In case of a temperature sensor failure, this setting determines the amount of time between refrigeration cycles.

4.5 DRIVE BELT TENSION ADJUSTMENT

To check belt tension, follow the steps below:

- A. Remove a side panel and the back panel.
- B. Use a Burroughs Belt Tension Gauge to set the tension for the drive belt. Set the belt tension to 35-45 lbs.
- C. If an adjustment is necessary, loosen the four motor plate retaining nuts, adjust belt tension then retighten the four nuts.

NOTE

Belt life will be increased if new drive belts are checked after two or three weeks of operation.

4.6 PREVENTATIVE MAINTENANCE

It is recommended that a maintenance schedule be followed to keep the machine clean and operating properly.

A. DAILY

1. The exterior should be kept clean at all times to preserve the luster of the stainless steel. A mild alkaline cleaner is recommended. Use a soft cloth or sponge to apply the cleaner.

CAUTION

Do not use acidic cleansers, strong caustic compounds or abrasive materials to clean any part of the machine exterior or plastic parts. Use of these types of cleaners will cause equipment damage.

B. WEEKLY

1. Check o-rings and the beater shaft seal for excessive wear and replace if necessary.
2. Remove the drip tray by gently lifting up to disengage from the support and pulling out. Clean behind the drip tray and front of the machine with a soap solution.

C. QUARTERLY

Lubricate Flow Control Assembly

1. With 3-In-One oil or equivalent, place a few drops of oil between the flow control arm and grommet (Fig. 4-3).
2. Rotate flow control knob to ensure proper coverage.



Figure 4-3 Flow Control Arm Lubrication

Clean Condenser and Filter

The air-cooled condenser is a copper tube and aluminum fin type. Condensing is dependent upon airflow. A plugged condenser filter or restrictions in the louvered panel will restrict airflow. This will lower the capacity of the system and damage the compressor.

The condenser must be kept clean of dirt and grease. The machine must have a minimum of 3" (7.5 cm) of ventilation on the right and left sides of the unit for free flow of air. Make sure the machine is not pulling over 100° F (37° C) air from other equipment in the area.

The condenser and condenser filter require periodic cleaning. To clean, refer to the following procedures.



WARNING

High voltage will shock, burn or cause death. Turn off and lock out main power disconnect before servicing. Do not operate machine with panels removed.

1. Remove the Phillips head screw from the bottom of the right side panel, and then slide the panel down and out.
2. To remove the condenser filter, grasp the top and pull off. Visually inspect for dirt. If the filter is dirty, shake or brush excess dirt off the filter and wash in warm, soapy water. Once the filter is clean rinse thoroughly in warm, clear water and shake dry, taking care not to damage the filter in any way.
3. Visually inspect the condenser for dirt by shining a light through the coil from the back (inside) of the condenser.
4. If the condenser is dirty, place a wet towel over the front (outside) of the condenser.
5. Using a vacuum, carefully clean the condenser coil from the inside and outside of the machine. A stiff bristled brush may help in releasing debris from between the condenser coils.

D. SEMI-ANNUALLY



WARNING

High voltage will shock, burn or cause death. Turn off and lock out main power disconnect before servicing. Do not operate machine with panels removed.

1. Check drive belt for proper tension. Push belt in with one finger, belt should deflect about 3/8".
2. Lubricate condenser fan motor with S.A.E. 20 weight oil. Three to six drops is required.

CAUTION

Do not over-lubricate; resulting damage could cause motor failure.

4.7 EXTENDED STORAGE

Refer to the following steps for storage of the machine over any long shutdown period:

- A. Turn the Main Freezer Power OFF-ON switch to the OFF position.
- B. Disconnect (unplug) from the electrical supply source.
- C. Clean all parts thoroughly with a warm water detergent. Rinse in clean water and dry parts. Do not sanitize.

NOTE

Do not let the cleaning solution stand in the hopper or in the freezing cylinder during the shutdown period.

- D. Remove, disassemble and clean the faceplate, flow control assembly and beater shaft parts. Place the blades and the beater shaft wearguard in a plastic bag with a moist paper towel to prevent them from becoming brittle.

SECTION 5 REFRIGERATION SYSTEM

5.1 REFRIGERATION SYSTEM

The CF101 refrigeration system has two functions:

Medium-Temperature - Maintaining product temperature in the hopper.

Low-Temperature - Producing and maintaining high quality custard in the freezing cylinder.

The system is designed for efficient use with R404A refrigerant. The proper charge is indicated on the information plate.

5.2 REFRIGERANT RECOVERY AND EVACUATION

Refer to the following procedures to properly recover and evacuate the refrigeration system. Do not purge refrigerant into the atmosphere.

NOTE

For qualified service personnel only. Anybody working with refrigerants must be certified as a Technician TYPE I as required by 40 CFR 82 Subpart F and hold all State and/or local refrigerant handling certifications. In addition, all handling, storage, and disposal of refrigerants must be in accordance with Environmental Protection Agency (EPA) guidelines and standards and all State and local guidelines and standards.



WARNING

Hazardous voltage

The Main Freezer Power switch must be placed in the OFF position when disassembling for servicing. The machine must be disconnected from electrical supply before removing any access panel. Failure to disconnect power before servicing could result in death or serious injury.

A. Refrigerant Recovery

1. Disconnect the machine from electrical supply before removing any panels for servicing.
2. Remove all panels.
3. Connect the recovery unit to the suction and discharge service valves of the compressor.
4. Locate the compressor contactor behind the header panel and disconnect the gray wire #47.
5. Wrap electrical tape around wire to insulate it.
6. Remove belt from the pulley to allow drive motor to spin freely.
7. Connect power to the machine.

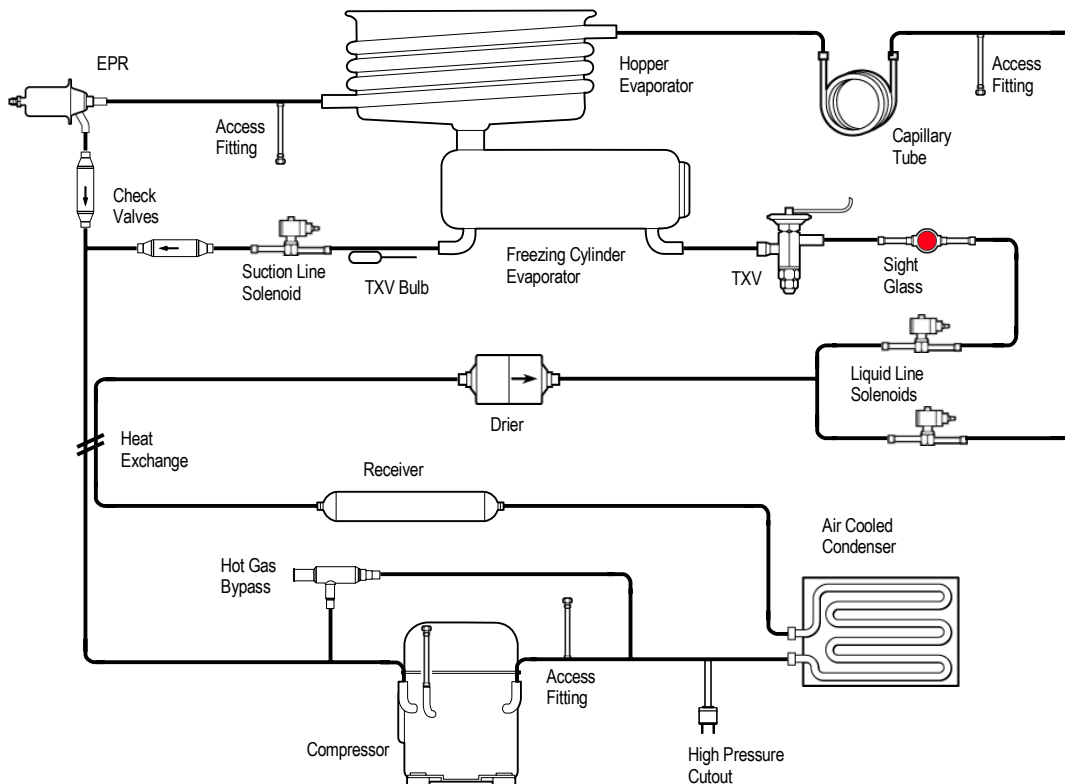

Figure 5-1 Refrigeration System

8. Turn the Main Power OFF/ON switch and Freezing Cylinder OFF/ON switches to the ON position.
9. Press the Push To Freeze button on the IntelliTec control. This will energize the solenoid valves.

CAUTION

The solenoid valves must be energized to allow all refrigerant to be recovered and to prevent injury when brazing.

10. Operate the recovery unit per manufacturer's instructions

NOTE

If recovery is not completed after 20 minutes, press the Push To Freeze button again. This will keep the solenoid valves open.

B. Evacuating the Refrigeration System

1. Close any open ports in the refrigeration system.
2. Connect a vacuum gauge to one of the access fittings next to an evaporator.
3. Connect the evacuation unit to the high side and low side access fittings of the compressor.
4. Locate the compressor contactor behind the header panel and disconnect the gray wire #47.
5. Wrap electrical tape around wire to insulate it.
6. Remove belts from the pulleys to allow drive motors to spin freely.
7. Connect power to the machine.
8. Turn the Main Power OFF/ON switch and Freezing Cylinder OFF/ON switches to the ON position.
9. Press the Push To Freeze button on the IntelliTec control. This will energize the solenoid valves.
10. Evacuate the system until the gauge reads 300 microns of mercury (300µ Hg) for 5 continuous minutes.

NOTE

If evacuation is not completed after 20 minutes, press the Push To Freeze button again. This will keep the solenoid valves open.

11. If the system will not maintain a standing vacuum test with the vacuum pump off (gauge increases towards atmosphere), find the leak, fix it, and evacuate again.

5.3 REFRIGERANT CHARGING

Refer to the following procedures to properly charge the refrigeration system. Stoelting recommends liquid refrigerant charging.

NOTE

For qualified service personnel only. Anybody working with refrigerants must be certified as a Technician TYPE I as required by 40 CFR 82 Subpart F and hold all State and/or local refrigerant handling certifications. In addition, all handling, storage, and disposal of refrigerants must be in accordance with Environmental Protection Agency (EPA) guidelines and standards and all State and local guidelines and standards.

 **WARNING**

Hazardous voltage
The Main Freezer Power switch must be placed in the OFF position when disassembling for servicing. The machine must be disconnected from electrical supply before removing any access panel. Failure to disconnect power before servicing could result in death or serious injury.

- A. Ensure the electrical supply has been removed before continuing.
- B. If the system has been opened or if there was a leak, refer to Section 5.2 - Refrigerant Recovery and Evacuation to evacuate the system prior to charging.
- C. Refer to machine's information plate for total charge requirements.

NOTE

The refrigeration system of the CF101 is critically charged. Be sure to charge the system to the weight listed on the machine's information plate.

- D. For liquid refrigerant charging, connect refrigerant cylinder to the discharge access fitting of the compressor.
- E. Energize the three solenoid valves. There are two liquid line solenoids and one suction line solenoid.
- F. Add the proper amount of refrigerant according to the machine's information plate.

5.4 COMPRESSOR

The CF101 has a hermetic reciprocating compressor (Refer to Figure 5-3).

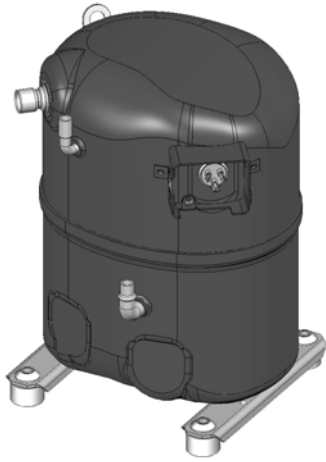

Figure 5-2 CF101 Compressor

A. WINDING TEST

To test the compressor motor windings for possible problems, perform the following steps:

- A. Disconnect the machine from electrical supply before removing any panels for servicing.
- B. Gently pry the white plastic ring off of the freezing cylinder on the front of the machine.
- C. Remove the front panel screws. The panel is still connected by the telephone wire.
- D. Reach behind the panel and disconnect the telephone wire on the display module.
- E. Remove the front panel.
- F. Remove the protective cover from the compressor terminals. Disconnect the three terminals; C (common), R (run), and S (start).
- G. Connect an ohmmeter to the C and R terminals on the compressor. Resistance through the run winding should be $1.16\Omega \pm 10\%$
- H. Connect an ohmmeter to the C and S terminals on the compressor. Resistance through the start winding should be $3.10\Omega \pm 10\%$
- I. To check if windings are shorted to ground, connect one ohmmeter lead to a bare metal part on the compressor (such as any copper line leading to or from the compressor) and check terminals C, R, and S.

NOTE

The compressor is equipped with an internal overload protector. If the compressor is warm and ohmmeter readings indicate an open winding, allow up to one hour for overload to reset.

B. COMPRESSOR REMOVAL

- A. Disconnect the machine from electrical supply before removing any panels for servicing.
- B. Gently pry the white plastic ring off of the freezing cylinder on the front of the machine.
- C. Remove the front panel screws. The panel is still connected by the telephone wire.
- D. Reach behind the panel and disconnect the telephone wire on the display module.
- E. Remove the front panel.
- F. Remove the protective cover from the compressor terminals and disconnect the wires.
- G. Recover refrigerant charge per the instructions in Section 5.2.
- H. Leave the suction and discharge ports open to prevent pressure buildup during compressor removal.
- I. Remove six inches of insulating tubing on the suction line going to the compressor and unsweat the suction and discharge line from the compressor.
- J. Remove the four nuts and washers from the base of the compressor.
- K. Remove the compressor through the front of the machine.
- L. Remove the four rubber compressor mounts from the compressor.
- M. Crimp and braze all open ports of the old compressor.

NOTE

A compressor returned to Stoelting with any open ports will void the warranty. ALWAYS crimp and braze ports on a compressor that has been removed.

C. COMPRESSOR INSTALLATION

- A. Make sure the machine is disconnected from the electrical supply before servicing.



WARNING

Hazardous voltage

The Main Freezer Power switch must be placed in the OFF position when disassembling for servicing. The machine must be disconnected from electrical supply before removing any access panel. Failure to disconnect power before servicing could result in death or serious injury.

- B. Install the four rubber mounts on the compressor.
- C. Install the compressor into the machine, fitting the base over the four bolt holes.
- D. Install the four washers and nuts onto the bolts and tighten securely.
- E. Remove all tubing plugs from the replacement compressor.

NOTE

The compressor plugs protect the compressor from moisture in the air. Do not remove the plugs until you are ready to install. The compressor must not be opened to the atmosphere for more than 10 minutes.

- F. Leave the suction and discharge ports open to prevent pressure buildup. Braze the suction and discharge line to the compressor.
- G. Connect the wires to the compressor terminals.
- H. Replace the drier per the instructions in Section 5.9.
- I. Evacuate the system per the instructions in Section 5.2
- J. Recharge the system per the instructions in Section 5.3.
- K. Replace the insulating tubing on the suction line.

5.5 CONDENSER

The CF101 is available with an air-cooled condenser. The capacity of the machine is directly related to keeping the condenser clean and free of debris.

The air-cooled condenser is a copper tube and aluminum fin type. The machine must have a minimum of 6" of clearance on the sides for proper air flow.

Condenser Testing

The condenser can be checked for leaks using the bubble test or using a leak detector.

5.6 EVAPORATOR

The CF101 has a freezing cylinder evaporator and a hopper evaporator.

Evaporator Testing

The evaporator can be checked for leaks using the bubble test or using a leak detector.

NOTE

Foam insulation around the evaporator will set off electronic leak detectors if disturbed.

5.7 VALVES

A. Thermostatic Expansion Valve (TXV)

The Thermostatic Expansion Valve (TXV) is used to meter the refrigerant to the evaporator. It does so by maintaining a low, constant superheat in the evaporator. The self-regulating TXV is preset by the manufacturer and adjustment is not recommended. Figure 5-4.

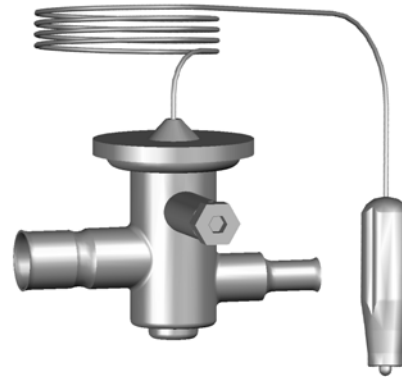

Figure 5-4 TXV

TXV Testing & Adjustment

When testing the TXV, disconnect the hopper liquid line solenoid.

NOTE

The bulb has an indent which must be positioned against the tubing. Good contact between the bulb and the suction line is necessary for proper operation of the valve. The bulb must also be well insulated.

- A. Connect a gauge to the access fitting on the suction line of the compressor.
- B. Connect a thermocouple to the suction line next to the evaporator.
- C. Immediately before the refrigeration cycle ends, the gauge should read between 19-20 psig and superheat should be 8°F.
- D. If the pressure reading is higher than expected and the superheat is low, check to see if there is an overcharge of refrigerant.
- E. If the pressure reading is lower than expected and the superheat is high, check to see if there is a low refrigerant charge or if there is a restriction in the system.

NOTE

The TXV is the LAST component to adjust in the refrigeration system.

- F. The TXV can be adjusted after the steps above are completed. When adjusting, do not turn the valve over 1/4 turn (90°). Turn the valve stem clockwise to increase the superheat or counterclockwise to decrease the superheat.

TXV Removal

- A. Disconnect the machine from electrical supply before removing any panels for servicing.
- B. Gently pry the white plastic ring off of the freezing cylinder on the front of the machine.
- C. Remove the front panel screws. The panel is still connected by the telephone wire.
- D. Reach behind the panel and disconnect the telephone wire on the display module.
- E. Remove the front panel.
- F. Remove the left side panel.
- G. Remove bulb from suction line exiting from the evaporator.
- H. Recover refrigerant charge per instructions in Section 5.2.
- I. Leave the suction and discharge ports open to prevent pressure buildup during TXV removal.
- J. Remove any insulation from the TXV and immediate surrounding lines.
- K. Apply a heat sink (wet cloth) to the valve dome (Figure 5-5).
- L. Unsweat the TXV and remove.

TXV Replacement

To replace the TXV, perform the following procedures:

- A. Position the TXV with a heat sink into the system.
- B. With the suction and discharge ports open, braze the TXV into the system using appropriate brazing material.
- C. Remove the heat sink from the TXV.
- D. Install bulb on suction line exiting the evaporator using existing clamp. The bulb has an indent which must be placed against the tubing.

NOTE

Good contact between the bulb and the suction line is necessary for proper operation of the valve. The bulb must also be well insulated.

- E. Tighten clamp to 20 in/lb using a torque wrench.
- F. Replace insulation to the TXV and surrounding lines.
- G. Replace the drier per the instructions in Section 5.9.
- H. Evacuate the system per the instructions in Section 5.2.
- I. Recharge the system per the instructions in Section 5.3.

B. Check Valve

The CF101 has 2 magnetic check valves (Refer to Figure 5-6). Both valves are on the suction side and prevent backflow of refrigerant into the evaporator. Without a check valve, reversed flow could cause product in the freezing cylinder to soften and liquid could flood the compressor on startup.

If a check valve needs to be replaced, use a heat sink (wet cloth) when installing the new valve to prevent damage.



Figure 5-6 Check Valve

C. High Pressure Cutout

The high pressure cutout stops the compressor if the discharge pressure reaches 445 psig (Refer to Figure 5-7).



Figure 5-7 High Pressure Cutout

High Pressure Cutout Test

- A. Connect a gauge to the access fitting on the discharge line.
- B. Disconnect the evaporator fan.
- C. High pressure cutout should trip when pressure reaches 445 psig \pm 10.

High Pressure Cutout Removal

- A. Remove the left side panel.
- B. Recover refrigerant charge per instructions in Section 5.2.
- C. Leave the suction and discharge ports open to prevent pressure buildup during removal.
- D. Unsweat capillary tube from suction line.
- E. Disconnect terminals from the high pressure cutout.

High Pressure Cutout Replacement

- A. With the suction and discharge ports open, braze the high pressure cutout to the discharge line.
- C. Replace the drier per the instructions in Section 5.9.
- D. Evacuate the system per the instructions in Section 5.2.
- E. Recharge the system per the instructions in Section 5.3.
- F. Connect the wires to the terminals to the high pressure cutout.

D. Hot Gas Bypass

The hot gas bypass valve is installed in parallel to the compressor and helps to regulate the compressor temperature (Refer to Figure 5-8). When the hopper evaporator is the only part of the system requiring refrigerant, the bypass valve will allow discharge gas to bypass into the suction line to prevent liquid refrigerant from entering the compressor.

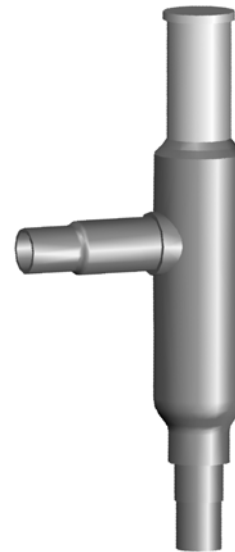

Figure 5-8 Hot Gas Bypass

Hot Gas Bypass Adjustment

NOTE

Before adjusting the hot gas bypass, check the EPR valve and adjust if necessary.

- A. Turn the Main Power OFF/ON switch to the OFF position.
- B. Remove the left side panel.
- C. Connect a gauge to the access fitting on the suction line of the compressor.
- D. Turn the Main Power OFF/ON switch to the ON position.
- E. After the hopper refrigeration starts, wait until the gauge to stop moving.
- F. Unscrew the seal cap from the top of the valve.
- G. Using a 5/16" Allen wrench, adjust the valve counterclockwise to decrease pressure and clockwise to increase pressure.

NOTE

Each 360° turn will change the pressure about 6 psig.

- H. Adjust the hot gas bypass valve to 14 psig \pm 1.
- I. Wait 2 minutes to ensure pressure remains stable.
- J. Hand-tighten seal cap to valve.

Hot Gas Bypass Removal

- A. Remove the left side panel.
- B. Recover refrigerant charge per instructions in Section 5.2.
- C. Remove insulation around hot gas bypass and tubing.

- D. Leave the suction and discharge ports open to prevent pressure buildup during hot gas bypass removal.
- E. Apply a heat sink (wet cloth) to the hot gas bypass.
- F. Unsweat the hot gas bypass and remove.

Hot Gas Bypass Replacement

To replace the hot gas bypass, perform the following procedures:

- A. Apply a heat sink (wet cloth) to the hot gas bypass.
- B. With an open port, braze the hot gas bypass into the system using appropriate brazing material.
- C. Remove the heat sink from the hot gas bypass.
- D. Replace the filter drier. Refer to Section 5.8 for details.
- E. Evacuate and recharge system per instructions in Section 5.2.

E. Evaporator Pressure Regulator (EPR)

There is one EPR in the CF101 refrigeration system (Refer to Figure 5-9). It is located on the suction line of the hopper and regulates evaporator refrigerant pressure.

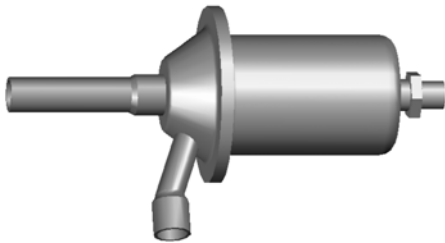

Figure 5-9 EPR Valve

EPR Test and Adjustment

- A. Place the Main Power OFF/ON switch in the OFF position.
- B. Connect a gauge to the access fitting on the suction line between the hopper evaporator and the EPR.
- C. Place the Main Power OFF/ON switch to the ON position.
- D. After the hopper refrigeration starts, the gauge should read 47 psig ± 1 . If it does not, then adjustment is needed.
- F. Remove the plastic cap and loosen the locknut on the EPR. Using a small screwdriver, turn the adjustment screw counterclockwise 1/2 turn, then adjust as necessary. Turn the valve stem clockwise for higher pressure or counterclockwise for lower pressure.
- G. Allow the system to stabilize for 2-3 minutes to ensure pressure remains stable.

EPR Removal

- A. Remove the side panel.
- B. Recover refrigerant charge per instructions in Section 5.2.
- C. Leave the suction and discharge ports open to prevent pressure buildup during EPR removal.
- D. Unsweat the EPR and remove.

EPR Replacement

To replace the EPR, perform the following procedures:

- A. Apply a heat sink (wet cloth) to the EPR.
- B. With an open port, braze the EPR into the system using appropriate brazing material.
- C. Remove the heat sink from the EPR.
- D. Replace the filter drier. Refer to Section 5.8 for details.
- E. Evacuate and recharge system per instructions in Section 5.2.

5.8 SOLENOID

Solenoid valves are installed on the liquid and suction line of the freezing cylinder evaporator and on the liquid line of the hopper evaporator (Refer to Figure 5-10). A solenoid valve has a magnetic coil that, when energized, lifts a plunger and allows refrigerant to flow. The solenoids are activated by the IntelliTec control and determine which evaporator receives refrigeration.

The suction line solenoid prevents refrigerant flow in the evaporator when the suction pressure drops due to the operation of the other evaporators in the system.

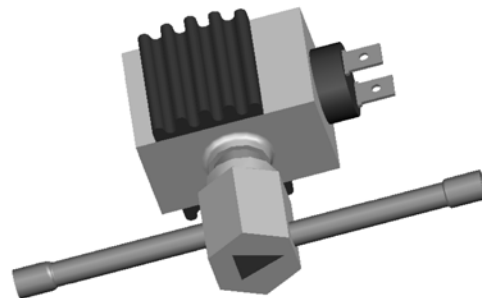

Figure 5-10 Solenoid Valve

Activating Solenoid Valves

To open the solenoids, follow these steps:

- A. Turn the Main Power OFF/ON switch to the OFF position.
- B. Locate the compressor contactor behind the header panel and disconnect the gray wire #47.
- C. Wrap electrical tape around wire to insulate it.
- D. Remove belts from the pulley to allow drive motor to spin freely.

- E. Connect power to the machine.
- F. Turn the Main Power OFF/ON switch to the ON position.
- G. Press the Push To Freeze button the IntelliTec control. This will energize the solenoid valves.

Suction Line Solenoid Testing

The following test will check for a leaking valve seat on the suction line solenoid. For this test, power is disconnected from the suction line solenoid and from the hopper liquid line solenoid.

- A. Turn the Main Power OFF/ON switch and the Freezing Cylinder OFF/ON switch to the OFF position.
- B. Disconnect a terminal on the suction line solenoid and on the hopper liquid line solenoid.
- C. Protect the terminal ends of the disconnected electrical lines with pieces of electrical tape.
- D. Place the Main Power OFF/ON switch to the ON position and press the Push To Freeze button.
- E. If frost appears on the valve, the valve seat leaks and should be replaced.

Liquid Line Solenoid Testing

The following test will check if a liquid line solenoid has a leaking valve seat. For this test, the power to the solenoid is disconnected and refrigerant flow is monitored through the system. If the valve seat does not leak, the suction pressure during the test will read the same as the pressure when only the hopper refrigeration is running.

- A. Turn the Main Power OFF/ON switch to the OFF position.
- B. Disconnect a terminal on the liquid line solenoid.
- C. Protect the terminal end of the disconnected electrical line with a piece of electrical tape.
- D. Attach gauges to the access fitting on the suction line of the compressor.
- E. Turn the Main Power OFF/ON switch to the ON position
- F. Start a freezing cycle by pressing the Push To Freeze button.
- G. The gauge should show approximately 14 psig after 1 minute.
- H. Watch the pressure in the freezing cylinder. If there is a pressure rise, the solenoid valve may have a leaking valve seat.

Solenoid Magnetic Coil Removal

- A. Remove the side panel.
- B. Disconnect the electrical wires.
- C. Remove the retainer screw from the top of the solenoid and pull the magnetic coil off.

Solenoid Magnetic Coil Installation

To replace the magnetic coil, perform the following procedures:

- A. Connect the two electrical wires to the magnetic coil.
- B. Push the coil on to the solenoid valve stem.
- C. Make sure there isn't any foam insulation between the valve coil and valve body. Trim any excess insulation.
- D. Install retainer screw onto top of coil.

Solenoid Valve Removal

- A. Recover refrigerant charge per instructions in Section 5.2.
- B. Remove insulation around valve and attached refrigeration lines.
- C. Apply heat sinks (wet cloth) to the insulated refrigerant lines near the valve.
- D. Leave a port open to prevent pressure buildup during solenoid removal.
- E. Identify and disconnect the two wires from the solenoid coil.
- F. Remove the retainer holding the coil to the solenoid body and remove the coil.
- G. Unsweat the solenoid and remove.

Solenoid Valve Replacement

To replace the solenoid, perform the following procedures:

- A. Position the new solenoid with the arrow pointing toward the direction of flow.
- B. Apply a heat sink (wet cloth) to the solenoid valve.
- C. With the suction and discharge ports open, braze the solenoid into the system using appropriate brazing material.
- D. Remove the heat sink from the valve.
- E. Replace insulation around valve.
- F. Replace the filter drier. Refer to Section 5.8 for details.
- G. Evacuate and recharge system per instructions in Section 5.2.

5.9 FILTER DRIER

The filter drier must be replaced every time the refrigeration system is opened for service. A new filter drier improves operation of the entire refrigeration system by stopping the circulation of moisture and by removing harmful contaminants (Refer to Figure 5-11).

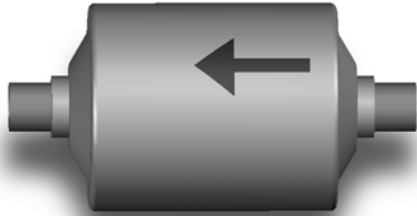

Figure 5-11 Filter Drier

Filter Drier Removal

- A. Recover refrigerant charge per instructions in Section 5.2.
- B. Cut the refrigeration line as close to the filter drier as possible and remove drier.
- C. Cap the ends of the drier using the plugs from the new drier.

NOTE

The drier must be capped to prevent moisture from the environment

Filter Drier Replacement

- A. Position the filter drier so the arrow is pointing towards the evaporators (pointing away from the condenser).
- B. Apply a heat sink (wet cloth) to the filter drier.
- C. With the suction and discharge ports open, braze the filter drier into the system using appropriate brazing material.
- D. Evacuate the system per instructions in Section 5.2.
- E. Recharge the system per instructions in Section 5.3.

5.10 CAPILLARY TUBE

The capillary tube meters refrigerant flow to the hopper evaporator (Refer to Figure 5-12). The rate of flow is dependent on the length and ID of the capillary tube as well as the refrigerant charge.

Capillary Tube Removal

- A. Recover refrigerant charge per instructions in Section 5.2.
- B. Leave a port open to prevent pressure buildup during capillary tube removal.



Figure 5-12 Capillary Tube

- C. Remove foam insulation from the capillary tube at the evaporator inlet.
- D. Unsweat the capillary tube and remove.

Capillary Tube Replacement

- A. Position the capillary tube in place.
- B. Apply a heat sink (wet cloth) to the capillary tube.
- C. With the suction and discharge ports open, braze the capillary tube into the system using appropriate brazing material.
- D. Replace foam insulation to the capillary tube at the evaporator inlet.
- E. Evacuate the system per instructions in Section 5.2.
- F. Recharge the system per instructions in Section 5.3.

5.11 RECEIVER (SER. #26919 PLUS)

The receiver is located in the liquid line and is used to ensure that the TXV receives a constant supply of liquid refrigerant.



Figure 5-13 Receiver

SECTION 6 ELECTRICAL AND MECHANICAL CONTROL SYSTEMS

NOTE

The wiring diagram is available in Section 8.

6.1 INTELLITEC CONTROLLER

The IntelliTec control is Stoelting's most advanced controller. It combines all of the best features of previous controllers with advanced sensing and troubleshooting capabilities.

A. COMPONENTS OF CONTROLLER

The IntelliTec control consists of three main components; the control board (Figure 6-1), the membrane switch (Figure 6-2), and the display panel module (Figure 6-3). The membrane switch is connected to the display panel module via a 9-pin ribbon cable. The display panel module is connected to the IntelliTec control board through a telephone cord. The IntelliTec control board is connected to the machine through an 8-pin connector, a 7-pin connector, and a 6-pin connector.

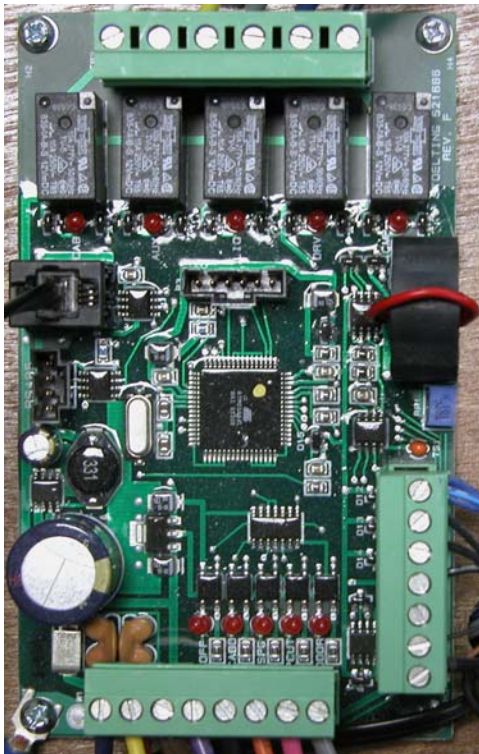

Figure 6-1 IntelliTec Control Board

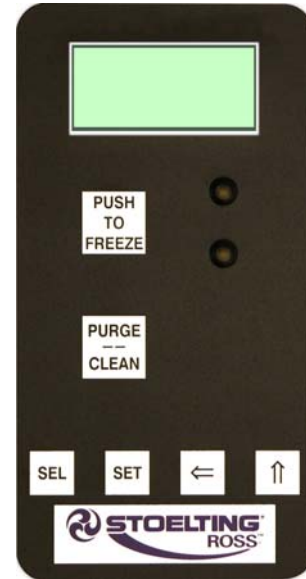

Figure 6-2 Membrane Switch

6.2 CONTACTORS

The compressor and drive motor contactors are mounted inside the electrical box behind the right panel. There is one contactor for the compressor and a contactor for the drive motor.

The IntelliTec control sends electronic signals to trigger the contactors. Separate signals are used to control the drive motor contactor and the compressor contactor. The signals to the contactors are staggered, so the drive motor will always start and stop three seconds before the compressor. By staggering the starting and stopping of the drive motor, maximum starting torque is available and voltage spikes are reduced.



Figure 6-3 Display Panel Module

A. CONTACTOR TESTS

The following tests will show if a contactor is working properly.

1. Remove the right panel and visually check the IntelliTec control board.
2. Check for a signal going to contactor. When the Push To Freeze button is pressed, the CMP LED on the control board will light (The DRV light may also light, depending on the temperature in the freezing cylinder). When the Purge button is pressed, the DRV button will light.

NOTE

In addition to the LEDs lighting, there will be an audible click from a contactor when the motor or compressor will starts.

3. Check to ensure contactor is receiving signal.

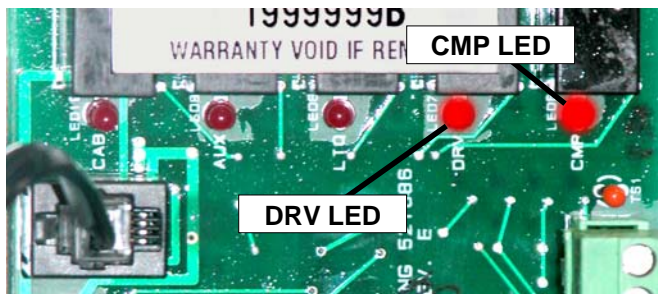

Figure 6-4 IntelliTec LEDs

Read voltage across the coils of the contactor during Run Mode. Voltage should be about 240V. If there is no voltage reading, refer to Section 7 Troubleshooting.

6.3 DRIVE MOTOR

The drive motor is designed specifically for the CF101 machine. The drive motor is used to rotate the beater shaft. An internal, normally closed, centrifugal switch starts the drive motor. The motor has an internal thermal overload.

A. DRIVE MOTOR REMOVAL

1. Disconnect the machine from the electrical supply before removing any panels for servicing.



WARNING

Hazardous voltage

The Main Freezer Power switch must be placed in the OFF position when disassembling for servicing. The machine must be disconnected from electrical supply before removing any access panel. Failure to disconnect power before servicing could result in death or serious injury.

2. Remove the rear panel and the left side panel.
3. Remove the belt tension adjustment nut and remove the belt.
4. Remove the two bolts on the motor mounting clamp and remove the clamp.
5. Slide the motor and motor mounting plate out the back of the machine to access the electrical cover plate.
6. Remove the electrical cover plate from the back of the motor.
7. Identify (mark) wires and remove them from the motor.
8. Remove the motor through the back of the machine.
9. Remove the motor mounting bolts and shims.
10. Loosen the two allen head screws from the pulley.

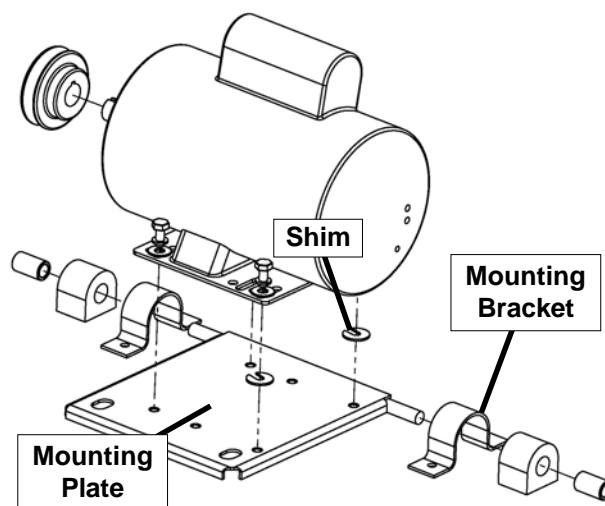

Figure 6-5 Motor Installation

11. Remove the pulley and key from the motor shaft.

B. DRIVE MOTOR INSTALLATION

1. Place the drive motor on the motor mounting plate and install the four mounting bolts and shims.
2. Install wiring according to wiring diagram (located behind header panel). Install electrical cover plate.
3. Install the motor mounting plate with the two bolts and the mounting clamp.
4. Place the pulley and key on the motor shaft.

NOTE

Do not tighten the pulley screws until after the belt tension has been properly adjusted.

5. Install the tension bolt.
6. Install the belt and tighten the tension bolt.

- 7 Test for proper belt tension by pressing firmly on the belt with an index finger. When the tension is properly adjusted, the belt should depress approximately 3/8" (roughly the width of the belt).
- 8 Using a straightedge, align the drive motor pulley with the gearbox pulley. Tighten the two allen head screws.
- 9 Install rear and side panel.

6.4 CAPACITORS

The compressor start and run contactors are mounted

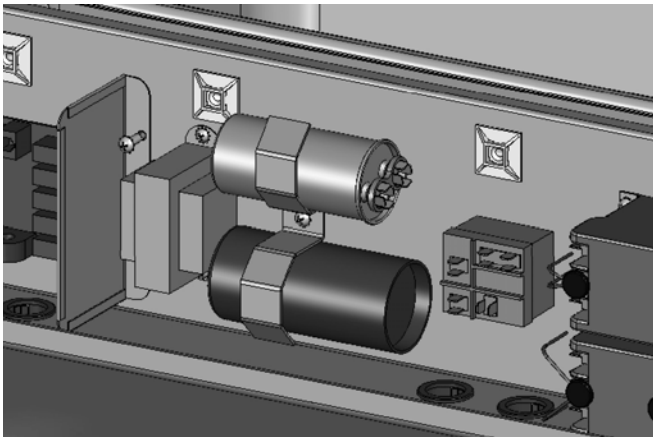

Figure 6-6 Compressor Capacitors

behind the right side panel. The start and run capacitors for the drive motor is mounted directly onto the motor body.

A. CAPACITOR TEST

1. Disconnect machine from electrical supply before removing any panels for servicing.
2. Place the Main Power OFF/ON switch and the Freezing Cylinder OFF/ON switch in the OFF position. Remove the right side panel.
3. Remove a lead from one of the capacitor terminals.
4. Using insulated pliers, create a short across the capacitor terminals with a 20KΩ 5W resistor to discharge the capacitor.

NOTE

Create the short even if there is a bleeder resistor across the terminals. There may be an open in the bleeder resistor preventing it from working properly.

	Part	Rating	
		MFD	VAC
Drive Motor Start	230635	125 MFD	250 VAC
Drive Motor Run	230636	15 MFD	480 VAC
Compressor Start	231079	145-174 MFD	220 VAC
Compressor Run	230633	30 MFD	370 VAC

5. Disconnect the bleeder resistor from the circuit.
6. Measure capacitance across the terminals. The results should be as follows:
7. Check the resistance across the capacitor terminals. The reading should be close to 0 and will rise slowly (as the meter charges the capacitor).
8. If the resistance stops increasing, there may be an internal short in the capacitor.
9. Short the capacitor if the test needs to be repeated.

B. CAPACITOR REPLACEMENT

1. Disconnect machine from electrical supply before removing any panels for servicing.
2. Place the Main Power OFF/ON switch and the Freezing Cylinder OFF/ON switch in the OFF position.
3. Remove leads from the capacitor terminals.
4. Using insulated pliers, create a short across the capacitor terminals with a 20KΩ 5W resistor to discharge the capacitor.

NOTE

Create the short even if there is a bleeder resistor across the terminals. There may be an open in the bleeder resistor preventing it from working properly.

5. Pull the capacitor out of its holder and replace. Make sure the new capacitor has a bleed resistor.
6. Connect the leads to the terminals.

6.5 GEARBOX

A. GEARBOX INSPECTION

Inspect the gearbox and listen for unusual noise. A grinding sound generally indicates a bad gear.



WARNING

Hazardous voltage

The Main Freezer Power switch must be placed in the OFF position when disassembling for servicing. The machine must be disconnected from electrical supply before removing any access panel. Failure to disconnect power before servicing could result in death or serious injury.

B. GEARBOX REMOVAL

1. Disconnect machine from electrical supply before removing any panels for servicing.
2. Remove the front door and remove the beater shaft.
3. Remove the rear panel and left side panel.
4. Remove the belt.

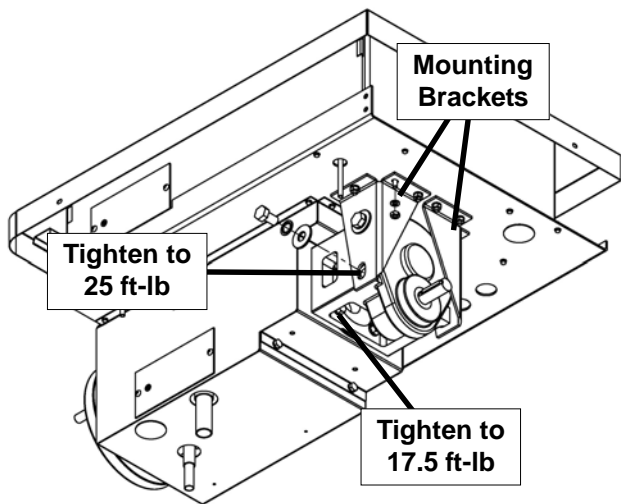

Figure 6-7 Gearbox

5. Remove the pulley by loosening the set screws.
6. Remove the four bolts holding the gearbox to the freezing cylinder.
7. Remove the six bolts holding the speed reducer mounting brackets.
8. Remove the gearbox and mounting brackets.
9. Remove the large bolts from the gearbox mounting brackets.

C. GEARBOX INSTALLATION

1. Install the mounting brackets to the gearbox using the large bolts. Tighten the bolts with a torque wrench to 25 foot-pounds.
2. Install the mounting brackets to the machine with the six bolts.
3. Install the gearbox to the back of the freezing cylinder. Tighten the bolts with a torque wrench to 17.5 foot-pounds.
4. Mount the pulley on the gear box shaft and align it with the motor pulley, then tighten the allen head screws.
5. Install the belt.
6. Press firmly on the belt.
7. When the tension is properly adjusted, the belt will depress the approximate width of the belt with the pressure of a finger.
8. If an adjustment is necessary, loosen the four motor plate retaining nuts, adjust belt tension then retighten the four nuts.
9. Install the beater shaft and front door.

6.6 CONDENSER FAN MOTOR

A. FAN MOTOR REPLACEMENT

1. Disconnect machine from electrical supply before removing any panels for servicing.



WARNING

Hazardous voltage

The Main Freezer Power switch must be placed in the OFF position when disassembling for servicing. The machine must be disconnected from electrical supply before removing any access panel. Failure to disconnect power before servicing could result in death or serious injury.

2. Remove a right panel and the rear panel.
3. Trace and disconnect the black and yellow wires on the T1 and T2 terminals on the compressor contactor.
4. Loosen set screw on fan blade.
5. Remove the four bolts from the fan motor mounting plate and remove the motor.

B. FAN MOTOR INSTALLATION

1. Attach motor to the mounting plate with the three bolts.
2. Place fan blade on motor shaft. Make sure the motor shaft does not extend past the hub of the fan blade. Tighten the set screw.

NOTE

The fan blades must be at least 3/8" from the fins on the condenser.

3. Ensure red wire is terminated with blue wire.
4. Route yellow and black wires to the compressor contactor behind the right panel.
5. Connect black wire to the T1 terminal.
6. Connect yellow wire to the T2 terminal.

6.7 POTENTIAL RELAY

The potential relay senses voltage produced by the start winding. When the rated pick-up voltage is reached, the relay will open and drop the start capacitor from the circuit.

6.8 TEMPERATURE CONTROL SENSOR

The temperature control sensor is a thermistor used to sense the temperature of the suction line. As the suction line temperature increases, the internal resistance of the thermistor will decrease. The IntelliTec control board monitors this value. In "Serve Mode", when the temperature of the sensor equals the Cut In T value on the control, the drive motor will start.

SECTION 7 TROUBLESHOOTING

7.1 ERROR CODES

When the machine experiences a problem, one of the following error codes will be displayed on the control panel. Each error code directs you to the system location of the malfunction.

ERROR CODE MALFUNCTION

1	Soft
2	High Torque
3	Extended Run Time
4	Clean
5	Barrel Sensor
6	Hopper Sensor
7	Drive Motor
8	Cab Sensor
9	High Pressure Cutout
10	Auxiliary Sensor

To return the machine to normal operation, any error causing condition must be corrected and the Main Freezer Power Off/On switch in the Off position and back in the On position before the machine will return to normal operation.

7.2 TROUBLESHOOTING ERROR CODES

Error Code 1 - Soft Error

The Soft Error (E1) is an internal control board error that is logged for future analysis. The refrigeration is never stopped and the machine will continue to operate normally.

Error Code 2 - High Torque

If the control panel displays a High Torque Error (E2), the drive motor is running at a high load for 10 or more seconds. Place the Main Freezer Power Off/On switch in the Off position, wait until the product in the freezing cylinder thaws to a reasonably soft consistency and return the switch to the On position. If the error persists, it could be a sign of very low and/or fluctuating supply voltage. The error can also be caused by faulty motor or starting components which could product a high amp draw.

Error Code 3 - Run Time

The Run Time Error (E3) occurs when the compressor runs continuously for an extended period. This error could happen if the cutout value is not attained during "Standby Mode" or if the "Ready" signal does not come on in "Custard Mode" or "Lemon Ice Mode".

The Run Time Error may also occur if airflow within the machine has reduced or stopped. Check the sides and top of the machine for anything that would restrict airflow. Check the condenser filter and clean if necessary. Check the evaporator for frost that could restrict airflow.

The compressor will run continuously if a solenoid valve fails to open. This could be due to loose wiring, magnetic coil failure, a stuck valve or a faulty control board.

After the cause of the problem is found and remedied place the Main Freezer Power Off/On switch in the Off position and back in the On position.

Error Code 4 - Clean

If the machine is left in the Clean Mode for more than 20 minutes, the control panel will display a Clean Error (Error 04). This condition does not reflect a problem with the machine itself. The Clean Error has been programmed into the controller as a safeguard to protect the machine from potential damage caused by the machine being accidentally left in "Clean Mode". The control will attempt to restart itself after 5 minutes. The display will then flash and read Restart. To immediately clear the Clean Error, place the Main Freezer Power Off/On switch in the Off position and back in the On position. After the Clean Error has been cleared, the machine will start a refrigeration cycle to protect the product in case the clean button was pressed by mistake.

Error Code 5 - Freezing Cylinder Sensor

The Freezing Cylinder Sensor Error (E5) indicates a failure of the freezing cylinder sensor or if the sensor is out of range. If the control panel displays an E5, place the Main Freezer Power Off/On switch in the Off position and back in the On position. If the control panel still displays the error code, refer to the machine's wiring diagram and the Temperature Sensor Chart (Figure 7-1). Check each lead of the sensor to ground for continuity. If continuity is found, replace the sensor. To check the resistance of the sensor, place a thermocouple on the suction line at the exit of the freezing cylinder. Compare temperature and sensor resistance with the table as reference. If measured value does not coincide with a value on the table (± 400 ohms), replace the sensor.

NOTE

When the machine encounters a Freezing Cylinder Sensor Error, the machine will continue to run using timers. This mode will allow the machine to continue making product until the machine is serviced.

Error Code 6 - Hopper Sensor

The Hopper Sensor Error (E6) indicates a failure of the hopper sensor or if the sensor is out of range. If the control panel displays an E6, place the Main Freezer Power Off/On switch in the Off position and back in the On position. If the control panel still displays the error condition code, refer to the machine's wiring diagram and the Temperature Sensor Chart (Figure 7-1). Check each lead of the sensor to ground for continuity. If continuity is found, replace the sensor. To check

the resistance of the sensor, place a thermocouple on the suction line at the exit of the freezing cylinder. Compare temperature and sensor resistance with the table as reference. If measured value does not coincide with a value on the table (± 400 ohms), replace the sensor.

Error Code 7 - Drive Motor

If the control panel displays a Drive Motor Error (E7), the control does not sense current coming from the drive motor. Place the Main Freezer Power Off/On switch in the Off position and back in the On position. If the error returns, use the machine's wiring diagram and check connections at the IntelliTec control and at the motor. An E7 may also be the result of a faulty drive motor contactor.

Error Code 8 - Cab Sensor

A Cab Sensor Error (E8) will not occur on the CF101 machine.

Error Code 9 - High Pressure Cutout

High Pressure Cutout Errors (E9) are usually caused by a dirty or inefficient condenser. If the control panel displays an E9, place the Main Freezer Power Off/On switch in the Off position and back in the On position.

In air cooled condenser models, check the air filter to make sure it is clean. Replace or clean the filter as required. Check for proper air clearance around the machine (6" on both sides). Check the condenser for blockage, and be sure condenser fan is functioning.

On water cooled condenser models, check for proper water flow through the condenser coil.

After the cause of the error is determined and corrected, place the Main Freezer Power Off/On switch in the Off position and back in the On position.

Error Code 10 - Auxiliary Sensor

An Auxiliary Temperature Sensor Error (E10) occurs if the temperature sensor on the control board fails. Place the Main Freezer Power Off/On switch in the Off position and back in the On position. If there is an E10 the control board may be faulty.

ALTERNATING FLASHING CONTROL PANEL LIGHTS

The display panel lights will flash in an alternating sequence under any error codes. Clear the error and place the Freezing Cylinder Off/On switch in the OFF position and back in the ON position.

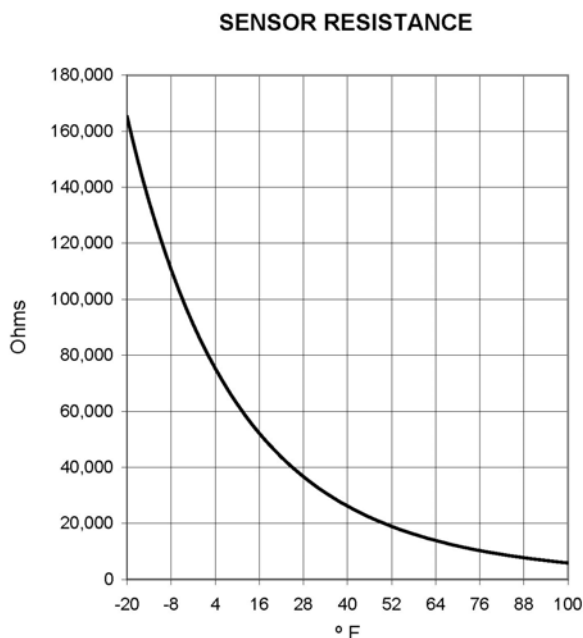

Figure 7-1 Temperature Sensor Resistance (10k Ohms)

7.3 TROUBLESHOOTING

PROBLEM	POSSIBLE CAUSE	REMEDY
Custard is running too cold or beater shaft blades chatter during running.	<ol style="list-style-type: none"> 1. Flow is not high enough. 2. Hopper is low or out of mix. 3. Flow valve is plugged. 4. The refrigeration system is set too cold for the mix. 	<ol style="list-style-type: none"> 1. Increase the flow. Machine needs to run for at least a minute before you see a change in the product. 2. Add Mix 3. Check flow valve. 4. Call Stoelting Technical Services for proper setting adjustment.
Custard is running too soft.	<ol style="list-style-type: none"> 1. Flow is too high. 2. Flow valve is plugged. 3. The refrigeration system for that freezing cylinder set too warm for the mix. 4. Condenser on remote unit is blocked. 5. Water cooled machine has water shut off. 6. Refrigeration system not functioning correctly. 	<ol style="list-style-type: none"> 1. Decrease the flow. Machine needs to run for at least a minute before you see a change in the product. 2. Check flow valve. 3. Call Stoelting Technical Services for proper setting adjustment. 4. Check for blockage and clean if necessary. 5. Check that water is connected and turned on. 6. Call Stoelting service department.
Beater motor freezes up in the run mode.	<ol style="list-style-type: none"> 1. Hopper is low or out of mix. 2. Flow valve is plugged. 3. Flow valve is set too low. 4. Belt is loose and slipping. 	<ol style="list-style-type: none"> 1. Add Mix 2. Check flow valve. 3. Increase the flow setting. 4. Check the belt and tighten if necessary.

SECTION 8 REPLACEMENT PARTS

8.1 DECALS AND LUBRICATION

Part	Description	Quantity
C-2000-57	Wrench - Beater Shaft	1
C74	O-Ring Pick	1
208135	Brush - 4" X 8" X 16" (Barrel)	1
208401	Brush - 1" X 3" X 10"	1
236048	Card - Cleaning Instruction	1
396243	Gasket - Freezer Base	1
490716	Leg	4
508048	Lubricant - Spline (2 oz Squeeze Tube)	1
508135	Petrol Gel - 4 oz Tube	1
513624	Manual - Owner's	1
324105	Decal - Caution Electrical Shock	1
324106	Decal - Caution Electrical Wiring Materials	1
324107	Decal - Caution Hazardous Moving Parts	1
324141	Decal - Caution Rotating Blades	1
324151	Decal - Field Connections	1
324208	Decal - Attention Refrigerant Leak Check	1
324509	Decal - Cleaning Instructions	1
324566	Decal - Wired According To	1
324584	Decal - Adequate Ventilation 3"	2
324594	Decal - Attention Heat Sensitive	1
324686	Decal - Danger Automatic Start	1
324728	Decal - Contactor Identification	1
324825	Decal - Main Freezer Power	1
324855	Decal - Flow Control	1
324856	Decal - Stoelting / Ross	1
324858	Decal - Custard / Italian Ice	1
324878	Decal - #149014 Wearguard	-
324879	Decal - #149003 Wearguard	-
324880	Decal - #149015 Wearguard	-

8.2 PANELS AND PANEL SCREWS

Part	Description	Quantity
647653	Screw - Panel	-
649000-39	Screw - Side Panel	-
2183900	Panel - Side	2
2183910	Panel - Rear	1
2183913	Panel - Header	1
2183993	Panel - Front	1

8.3 BEATER SHAFT AND FACEPLATE PARTS

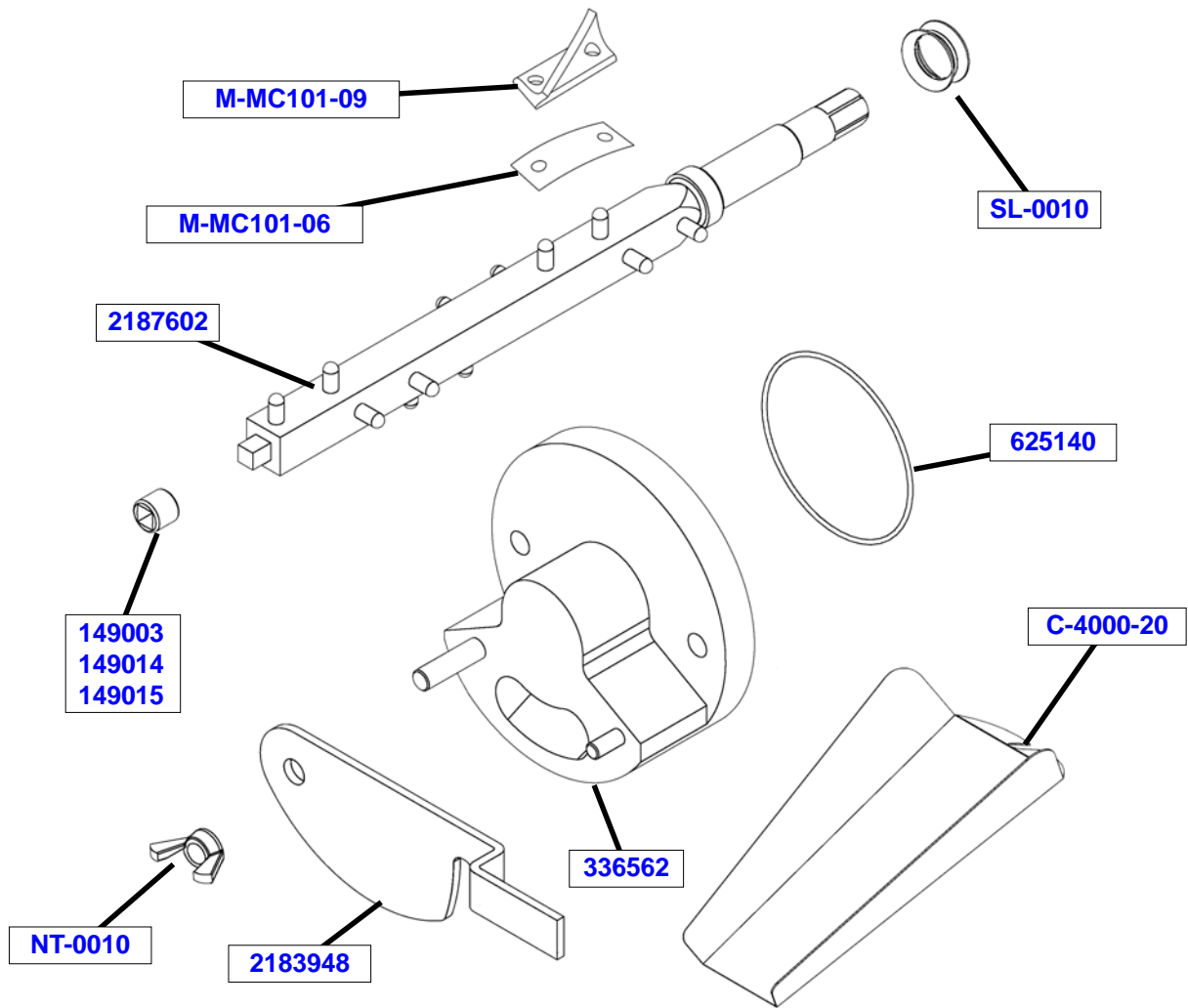

Part	Description	Quantity
C-2000-40	Wearguard - Beater Shaft (Ser. #0 - #26918)	-
C-4000-19	Slide - Long (Chute)	1
C-4000-20	Slide - Short (Chute)	1
M-MC101-06	Spring - Auger Blade	8
M-MC101-09	Blade - Auger	8
NT-0010	Wing Nut - Stainless Steel	4
SL-0010	Seal - Beater Shaft (Ser. #26919 Plus)	1
149003	Wearguard - Beater Shaft (Ser. #26919 Plus)	1
149014	Wearguard - Front Beater Shaft (Small)	-
149015	Wearguard - Front Beater Shaft (Large)	-
336557	Face Plate - Italian Ice	-
336558	Face Plate (Ser. #0 - #26918)	-
336562	Face Plate (Ser. #26919 Plus)	1
624678	O-Ring - Rear Seal - Black (Ser. #0 - #26918)	-
625140	O-Ring - Face Plate	1
667868	Seal - Rear Auger (Orange) (Ser. #0 - #26918)	-
674182	Beater Shaft (Ser. #0 - #26918)	-
1151859	Adapter - Rear Seal (Code 1) (Ser. #0 - #26918)	-
2183948	Gate - Face Plate	1
2187602	Beater Shaft (Ser. #27789 Plus)	1
2187609	Beater Shaft (Ser. #26919 - # 27431)	-
2187654	Beater Shaft (Ser. #27432 - #27788)	-

8.4 HOPPER PARTS AND TRAYS

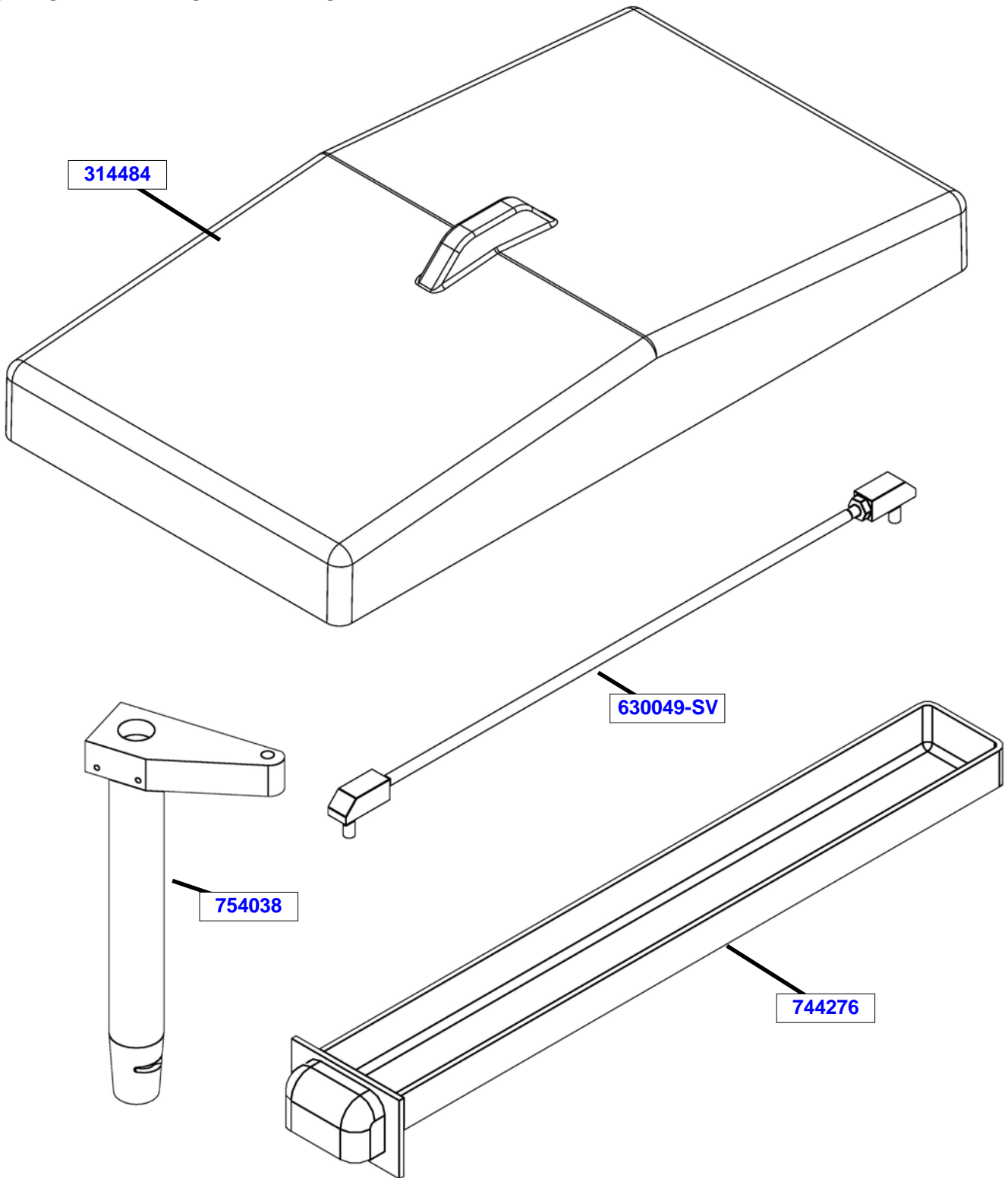

Part	Description	Quantity
314484	Cover - Hopper	1
417010	Grid - Drip Tray	1
630049-SV	Rod - Flow Control	1
744276	Tray - Drain	1
744287	Tray - Drip	1
754038	Tube - Flow Control (Hopper)	1

8.5 ELECTRICAL PANEL

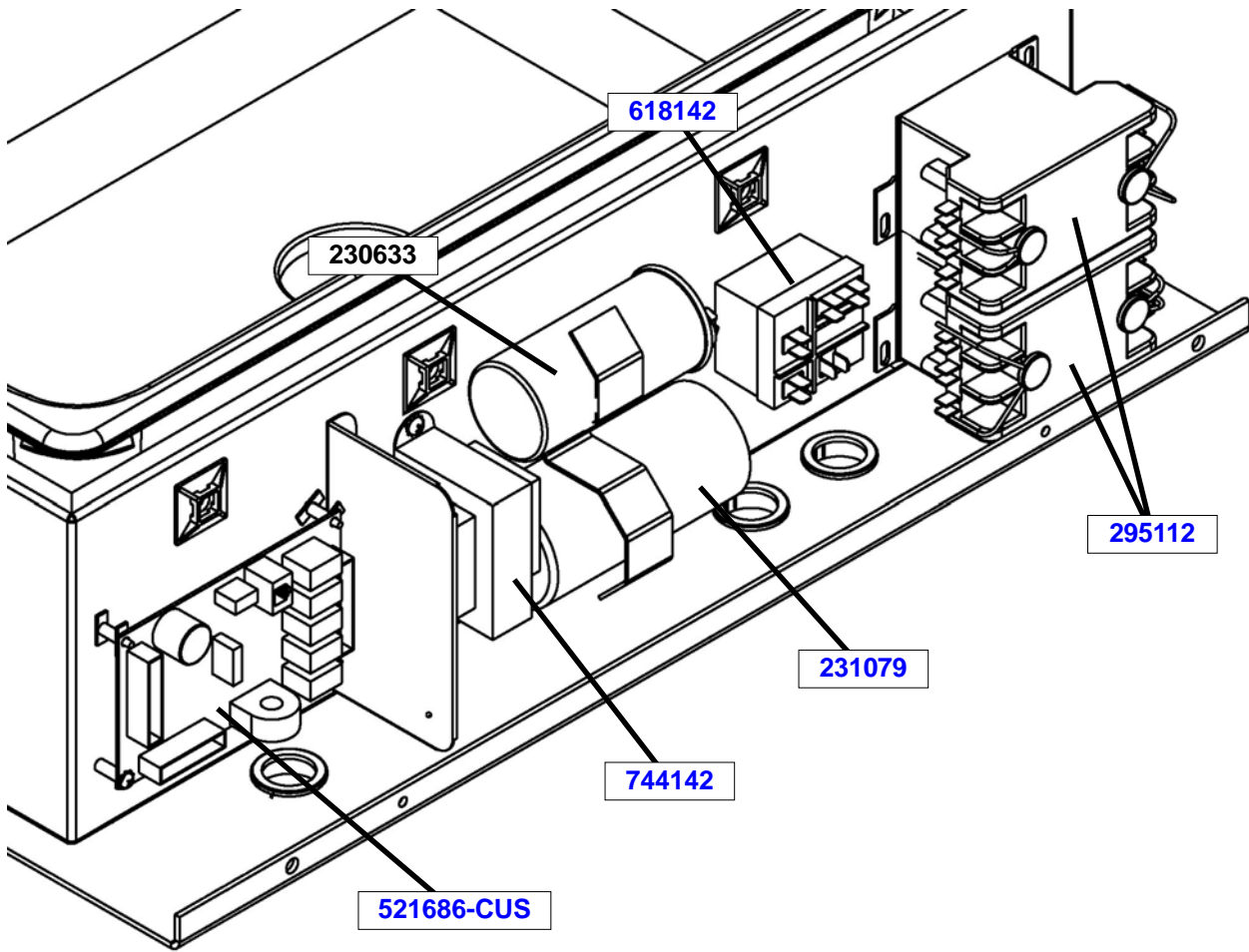

Part	Description	Quantity
230633	Capacitor - Run (60 Hz Compressor)	1
231046	Capacitor - Start (50 Hz Compressor)	1
231047	Capacitor - Run (50 Hz Compressor)	1
231079	Capacitor - Start (60 Hz Compressor)	1
295112	Contactors	2
521686-CUS	Program Board - IntelliTec (Custard)	1
618142	Relay (60 Hz Compressor)	1
618195	Relay (50 Hz Compressor)	-
744142	Transformer	1

8.6 FRONT

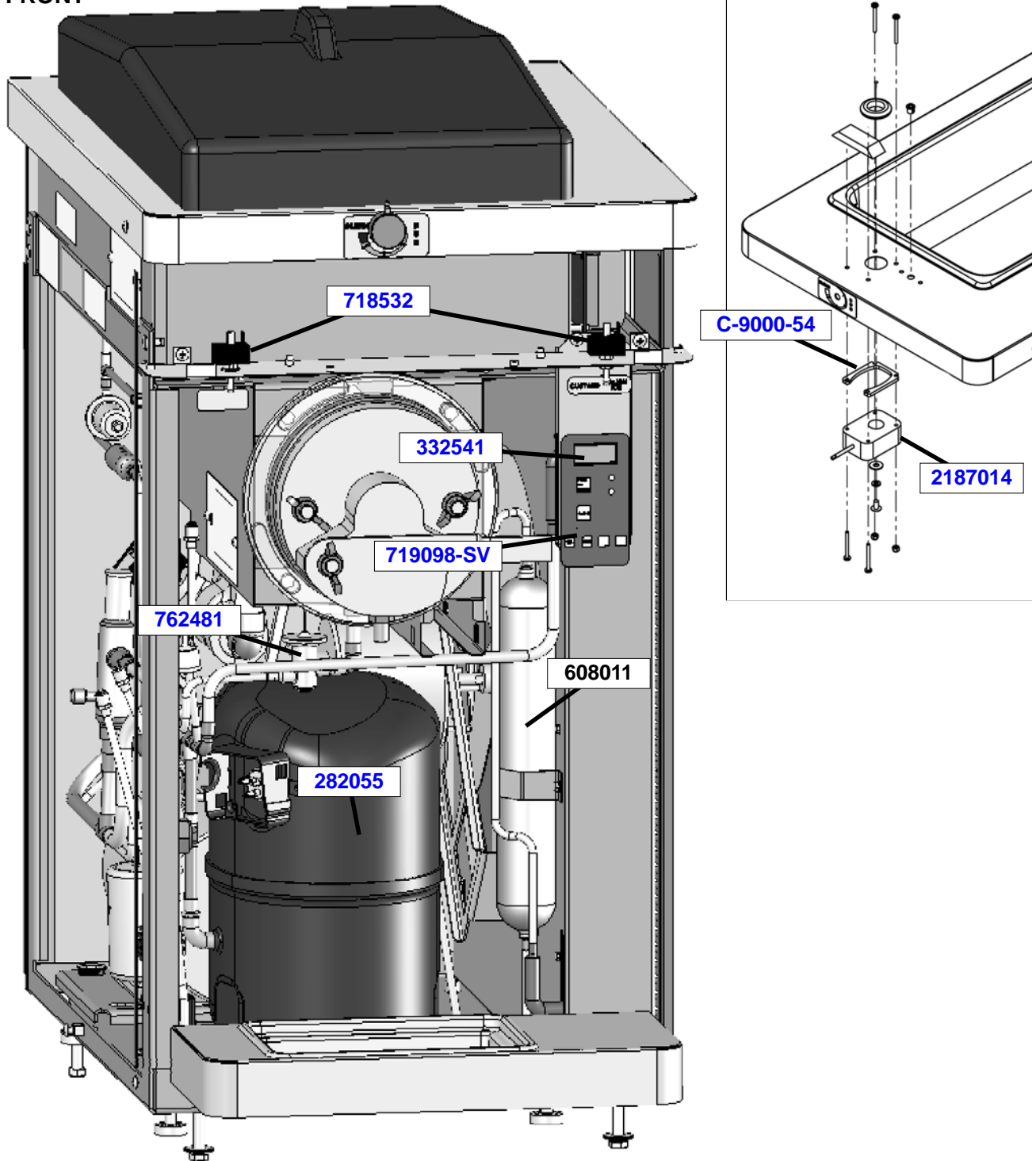

Part	Description	Quantity
C-9000-54	Shim - Gearbox	1
282055	Compressor - Copeland (60 Hz)	1
282056	Compressor - Copeland (50 Hz)	-
332541	Board - Display Module	1
608011	Receiver (Ser. #26919 Plus)	1
718532	Switch - Toggle	1
719098-SV	Switch - Membrane Strip	1
762481	Valve - Expansion	1
2183967	Support - Drip Tray	1
2187014	Gearbox Assembly w/ Knob	1

8.7 REAR

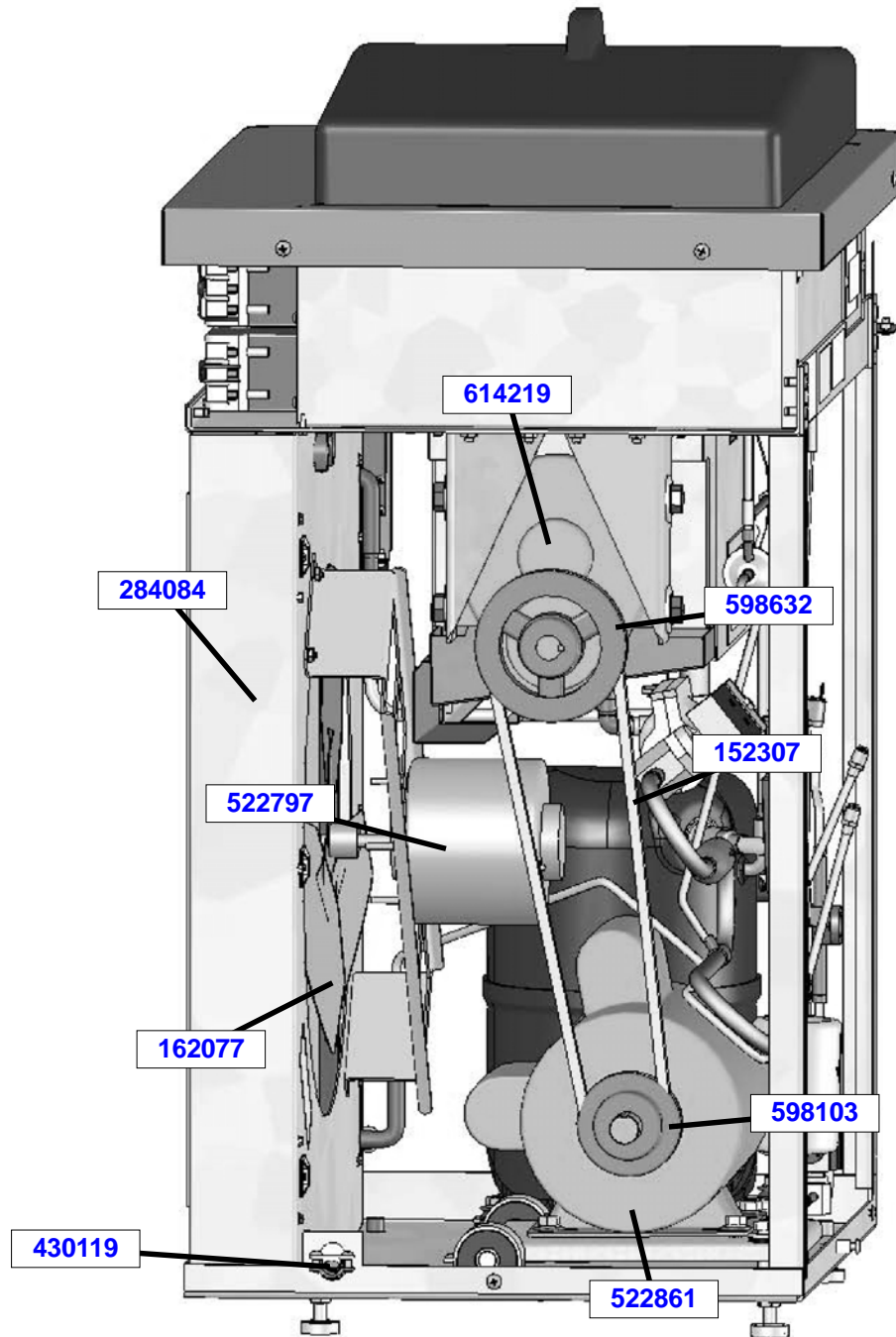

Part	Description	Quantity
152307	Belt - AX38 (60 Hz)	1
152323	Belt - Gripnotch (AX39) (Each) (50 Hz)	-
162077	Blade - Fan (Air-Cooled Condenser)	1
284084	Condenser (Air-Cooled)	1
368140	Filter - Air	1
430119	Cord - Power	1
522797	Motor - Fan	1
522861	Motor - Drive (1-1/2 HP)	1
598103	Pulley - Drive Motor	1
598108	Pulley - Drive Motor (50 Hz)	1
598632	Pulley - Speed Reducer (60 Hz)	1
614219	Speed Reducer	1

8.8 LEFT SIDE

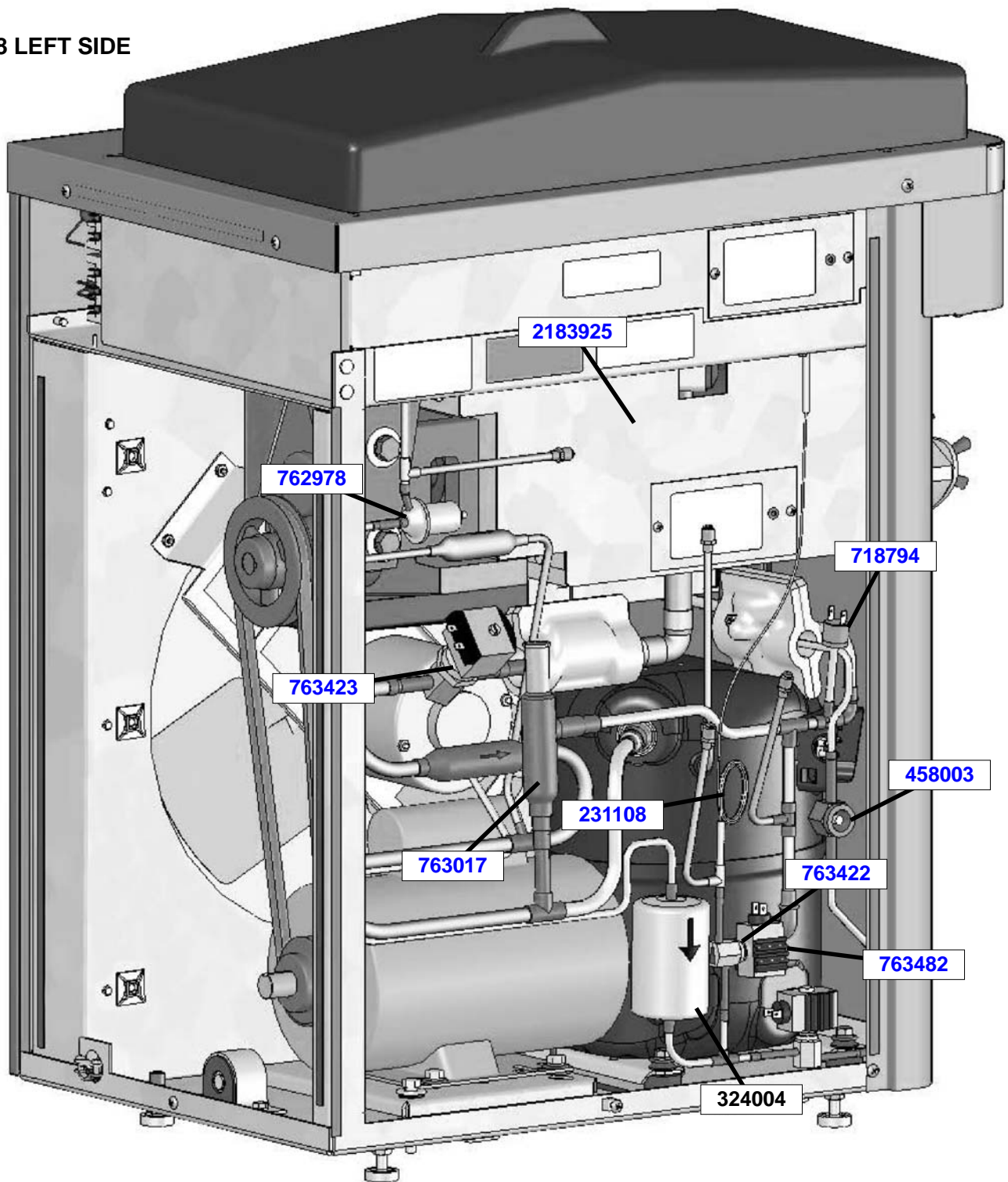

Part	Description	Quantity
C-5000-66	Flange - Bushing (Ser. #27432 - #27788)	-
C-5000-67	Nut - Flange Bushing (Ser. #27432 - #27788)	-
231108	Cap Tube Only	1
342004	Drier	1
458003	Indicator - Liquid Line	1
718794	Switch - High Pressure	1
762978	Valve - EPR	1
763017	Valve - Hot Gas Bypass	1
763422	Valve - Solenoid (1/4")	2
763423	Valve - Solenoid (1/2") (Suction Side)	1
763482	Valve Coil - Solenoid (#763422)	2
2183925	Evaporator	1

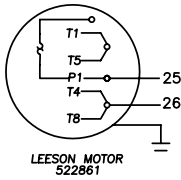
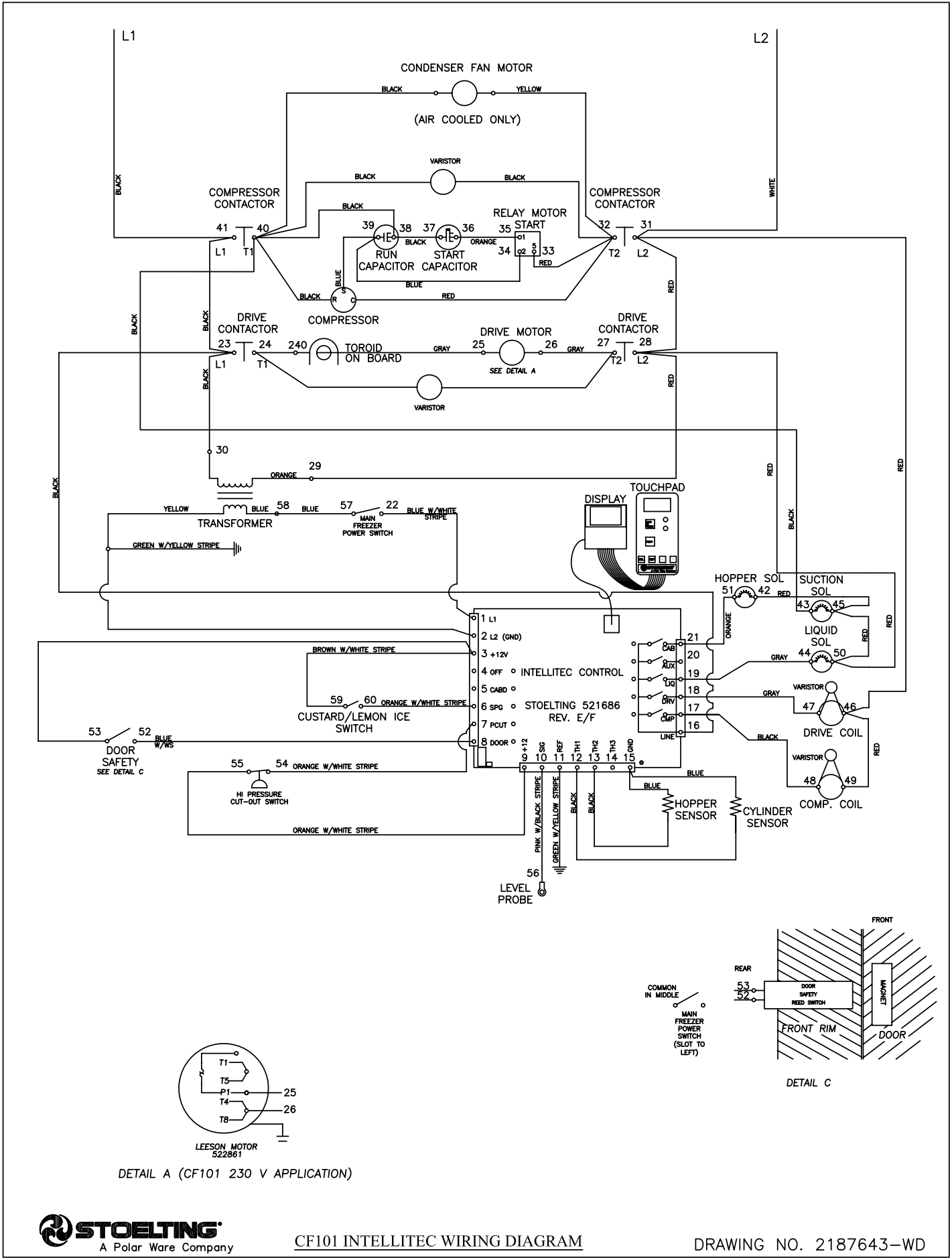

DETAIL A (CF101 230 V APPLICATION)

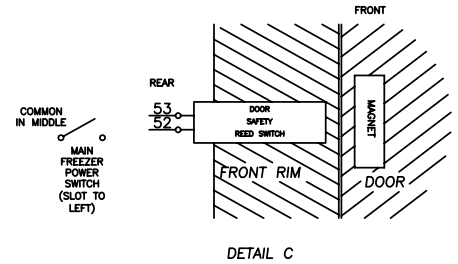



**WARRANTY
CUSTARD EQUIPMENT AND BATCH EQUIPMENT**

1. **Scope:**
PW Stoelting, L.L.C. (“Stoelting”) warrants to the first user (the “Buyer”) that the freezing cylinders, hoppers, compressors, drive motors, speed reducers, beaters, and auger shafts of Stoelting custard equipment and batch equipment will be free from defects in materials and workmanship under normal use and proper maintenance appearing within two (2) years, and that all other components of such equipment manufactured by Stoelting will be free from defects in material and workmanship under normal use and proper maintenance appearing within twelve (12) months after the date that such equipment is originally installed.

2. **Disclaimer of Other Warranties:**

THIS WARRANTY IS EXCLUSIVE; AND STOELTING HEREBY DISCLAIMS ANY IMPLIED WARRANTY OF MERCHANTABILITY OR FITNESS FOR PARTICULAR PURPOSE.

3. **Remedies:**
Stoelting’s sole obligations, and Buyer’s sole remedies, for any breach of this warranty shall be the repair or (at Stoelting’s option) replacement of the affected component at Stoelting’s plant in Kiel, Wisconsin, or (again, at Stoelting’s option) refund of the purchase price of the affected equipment, and, during the first twelve (12) months of the warranty period, deinstallation/reinstallation of the affected component from/into the equipment. Those obligations/remedies are subject to the conditions that Buyer (a) signs and returns to Stoelting, upon installation, the Start-Up and Training Checklist for the affected equipment, (b) gives Stoelting prompt written notice of any claimed breach of warranty within the applicable warranty period, and (c) delivers the affected equipment to Stoelting or its designated service location, in its original packaging/crating, also within that period. Buyer shall bear the cost and risk of shipping to and from Stoelting’s plant or designated service location.

4. **Exclusions and Limitations:**
This warranty does not extend to parts, sometimes called “wear parts”, which are generally expected to deteriorate and to require replacement as equipment is used, including as examples but not intended to be limited to o-rings, auger seals, auger support bushings, and drive belts. All such parts are sold

AS IS.

Further, Stoelting shall not be responsible to provide any remedy under this warranty with respect to any component that fails by reason of negligence, abnormal use, misuse or abuse, use with parts or equipment not manufactured or supplied by Stoelting, or damage in transit.

THE REMEDIES SET FORTH IN THIS WARRANTY SHALL BE THE SOLE LIABILITY STOELTING AND THE EXCLUSIVE REMEDY OF BUYER WITH RESPECT TO EQUIPMENT SUPPLIED BY STOELTING; AND IN NO EVENT SHALL STOELTING BE LIABLE FOR ANY INCIDENTAL OR CONSEQUENTIAL DAMAGES, WHETHER FOR BREACH OF WARRANTY OR OTHER CONTRACT BREACH, NEGLIGENCE OR OTHER TORT, OR ON ANY STRICT LIABILITY THEORY.