



Model E112 / F112
SERVICE MANUAL

Manual No. [513632](#)

Rev.3

This manual provides basic information about the machine. Instructions and suggestions are given covering its operation and care.

The illustrations and specifications are not binding in detail. We reserve the right to make changes to the machine without notice, and without incurring any obligation to modify or provide new parts for machines built prior to date of change.

DO NOT ATTEMPT to operate the machine until instructions and safety precautions in this manual are read completely and are thoroughly understood. If problems develop or questions arise in connection with installation, operation, or servicing of the machine, contact Stoelting.



stoeltingfoodservice.com

Stoelting Foodservice Equipment
502 Highway 67
Kiel, WI 53042-1600
U.S.A.

Main Tel: 800.558.5807
Fax: 920.894.7029

Customer Service: 888.429.5920
Fax: 800.545.0662
Email: foodservice@stoelting.com

© 2014 PW Stoelting, LLC

A Few Words About Safety

Safety Information

Read and understand the entire manual before operating or maintaining Stoelting equipment.

This manual provides the operator with information for the safe operation and maintenance of Stoelting equipment. As with any machine, there are hazards associated with their operation. For this reason safety is emphasized throughout the manual. To highlight specific safety information, the following safety definitions are provided to assist the reader.

The purpose of safety symbols is to attract your attention to possible dangers. The safety symbols, and their explanations, deserve your careful attention and understanding. The safety warnings do not by themselves eliminate any danger. The instructions or warnings they give are not substitutes for proper accident prevention measures.

If you need to replace a part, use genuine Stoelting parts with the correct part number or an equivalent part. We strongly recommend that you do not use replacement parts of inferior quality.



Safety Alert Symbol:

This symbol Indicates danger, warning or caution. Attention is required in order to avoid serious personal injury. The message that follows the symbol contains important information about safety.

Signal Word:

Signal words are distinctive words used throughout this manual that alert the reader to the existence and relative degree of a hazard.



The signal word "WARNING" indicates a potentially hazardous situation, which, if not avoided, may result in death or serious injury and equipment/property damage.



The signal word "CAUTION" indicates a potentially hazardous situation, which, if not avoided, may result in minor or moderate injury and equipment/property damage.

CAUTION

The signal word "CAUTION" not preceded by the safety alert symbol indicates a potentially hazardous situation, which, if not avoided, may result in equipment/property damage.

NOTE (or NOTICE)

The signal word "NOTICE" indicates information or procedures that relate directly or indirectly to the safety of personnel or equipment/property.

TABLE OF CONTENTS

Section	Description	Page
1	Description and Specifications	
1.1	Description.....	1
1.2	Specifications	2
1.3	Modes of Normal Operation	4
1.4	Operation During an Error Mode	5
2	Installation Instructions	
2.1	Safety Precautions	7
2.2	Shipment and Transit.....	7
2.3	Machine Installation.....	7
3	Initial Set-Up and Operation	
3.1	Operator's Safety Precautions	9
3.2	Operating Controls and Indicators	9
3.3	Sanitizing	10
3.4	Freeze Down and Operation	11
3.5	Mix Information	11
3.6	Removing Mix From Machine	12
3.7	Cleaning the Machine	12
3.8	Disassembly of Machine Parts	12
3.9	Cleaning and Sanitizing the Machine Parts.....	13
3.10	Sanitize Machine	13
3.11	Assembly of Machine	14
3.12	Routine Cleaning	15
3.13	Preventive Maintenance	15
3.14	Extended Storage.....	17
4	Maintenance and Adjustments	
4.1	Machine Adjustment	19
4.2	Product Consistency Adjustment.....	19
4.3	Convert Slush to Shake	19
4.4	Drive Belt Tension Adjustment.....	19
4.5	Condenser Cleaning	19
4.6	Preventative Maintenance	20
4.7	Extended Storage.....	20

Section	Description	Page
5	Refrigeration System	
5.1	Refrigeration System	21
5.2	Refrigerant Recovery and Evacuation	21
5.3	Refrigerant Charging	22
5.4	Compressor	22
5.5	Condenser	24
5.6	Valves	24
5.7	Capillary Tube.....	27
5.8	Filter Drier.....	28
6	Electrical and Mechanical Control Systems	
6.1	Control Board	29
6.2	Contactors	29
6.3	Drive Motor	30
6.4	Capacitors	31
6.5	Gearbox.....	32
6.6	Condenser Fan Motor (Air-Cooled Only).....	32
6.7	Switches	32
7	Troubleshooting	
7.1	Light Indicators	35
7.2	Troubleshooting.....	35
8	Replacement Parts	
8.1	Decals, Lubrication, Panels & Legs.....	37
8.2	Auger Shaft and Faceplate Parts	38
8.3	Hopper Parts	40
8.4	Machine Front & Spigot Switch Assembly	41
8.5	E112 Parts	42
8.6	F112 Parts	44
8.7	Retrofit Kits	46
8.8	Refrigeration Diagram	47
8.9	E112 Wiring Diagram.....	48
8.10	F112 Wiring Diagram.....	50
8.11	Autofill Options	52

SECTION 1 DESCRIPTION AND SPECIFICATIONS

1.1 DESCRIPTION

The Stoelting E112/F112 counter machines are gravity fed. The machines are equipped with fully automatic controls to provide a uniform product. They will operate with almost any type of shake or frozen beverage mix. This manual is designed to help qualified service personnel and operators with the installation, operation and maintenance of the Stoelting E112/F112 gravity machines.



Figure 1-1 Model E112



Figure 1-1 Model F112

1.2 SPECIFICATIONS

E112

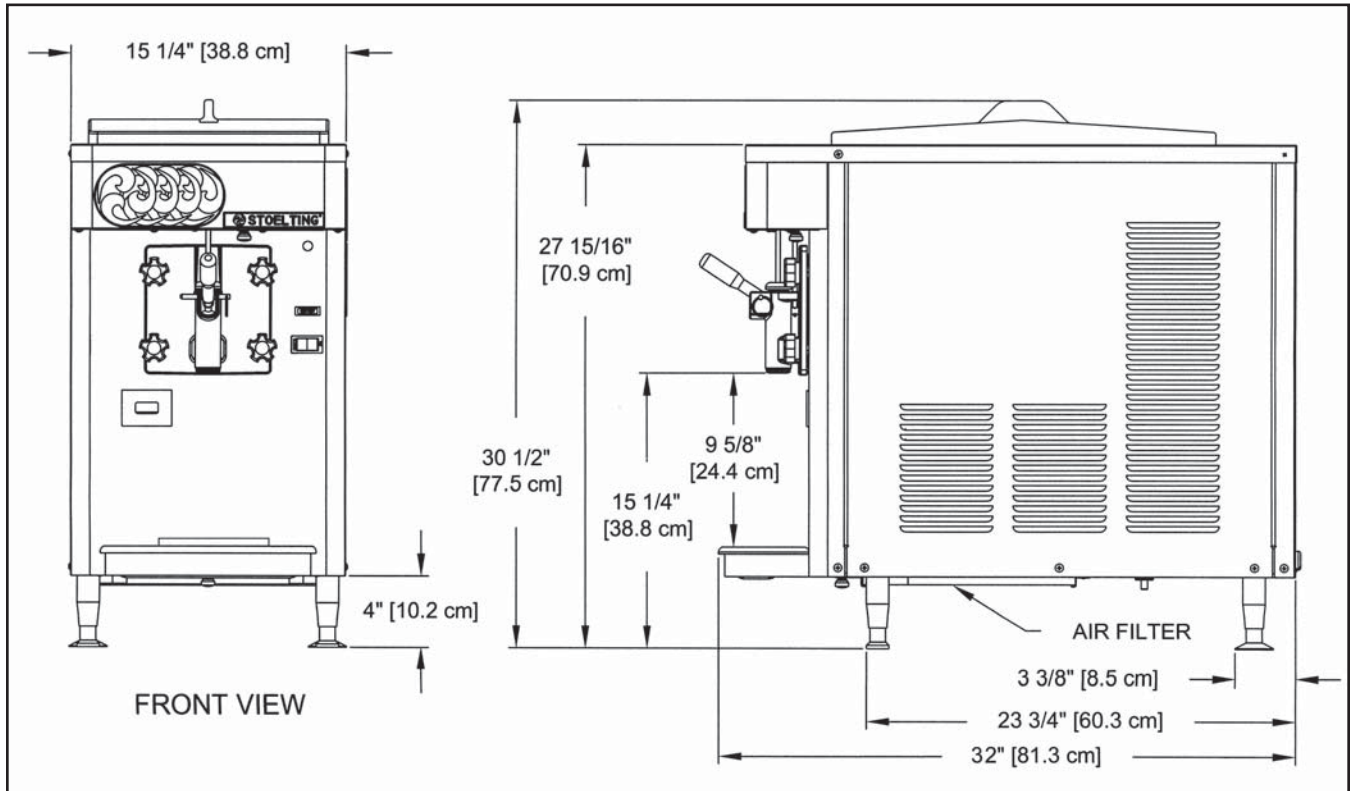

F112

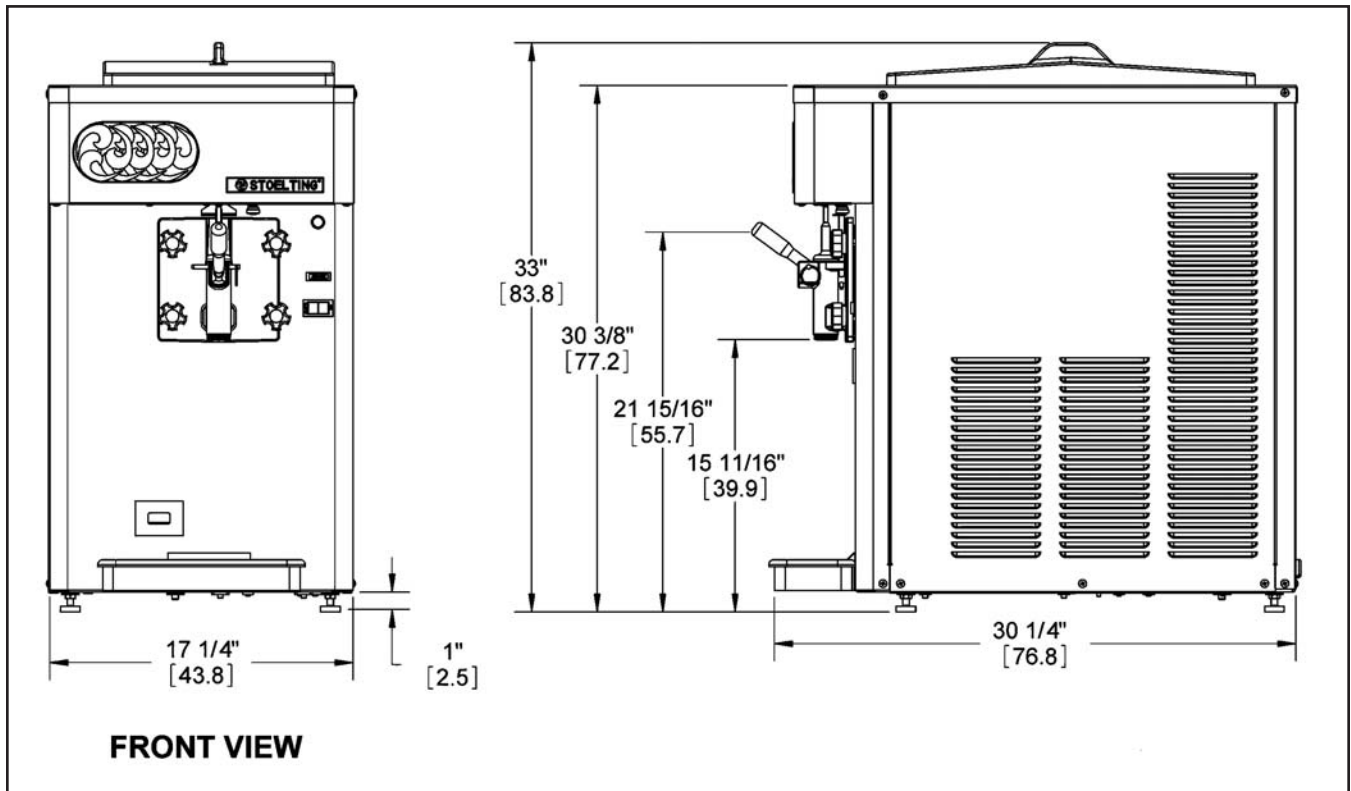

Figure 1-2 Specifications

1.2 SPECIFICATIONS - CONTINUED

	Model E112		Model F112		
Dimensions	Machine	with crate	Machine	with crate	
	width	15-1/4" (38,7 cm)	17-1/2" (44,5 cm)	17-1/4" (43,8 cm)	29" (73,7 cm)
	height	30-1/2" (77,5 cm)	35" (88,9 cm)	33" (83,8 cm)	44" (111,8 cm)
depth	32" (81,3 cm)	36-1/2" (92,7 cm)	30-1/4" (76,8 cm)	39" (99,1 cm)	
Weight	205 lbs (92,9 kg)	215 lbs (97,5 kg)	288 lbs (130,6 kg)	315 lbs (142,8 kg)	
Electrical	1 Phase, 115 VAC, 60Hz		1 Phase, 208-240 VAC, 60Hz		
	running amps	16A	10A		
connection type	NEMA5-20P power cord provided		NEMA6-15P power cord provided		
International Option	1 Phase, 220-240 VAC, 50Hz		1 Phase, 220-240 VAC, 50Hz		
Compressor	6,000 Btu/hr		8,600 Btu/hr		
Drive Motor	1/3 hp		3/4 hp		
Air Flow	Air cooled units require 3" (7,6 cm) air space on both sides or 4" (10,2 cm) air space in back for side-by-side installation		Air cooled units require 6" (15,24 cm) air space on both sides		
Plumbing Fittings	N/A		Water cooled units require 3/8" N.P.T. water and drain fittings.		
Hopper Volume	3.625 gallon (13,73 liters)		5.375 gallon (20,35 liters)		
Freezing Cylinder Volume	1.25 gallon (4,73 liters)		2.125 gallon (8,04 liters)		
Production Capacity	18 GPH (68,15 liters)		24 GPH (90,87 liters)		

	E112
Refrigerant	R-404A
Charge	20 oz
Suction Pressure (at 72°F)	Shake 22-24 psig Slush 30-32 psig
Discharge Pressure	Shake 205-215 psig Slush 200-205 psig
EPR Valve	59-61 psig

	F112
Refrigerant	R-404A
Charge	(W/C) 20 oz (A/C) 28 oz
Suction Pressure (at 72°F)	Shake 30-32 psig Slush 40 psig
Discharge Pressure	Shake 245-250 psig Slush 280 psig
EPR Valve	59-61 psig

1.3 MODES OF NORMAL OPERATION

Following is an explanation of the normal operation modes on the E112 and F112 (Refer to Figure 1-3).

NOTE

The following modes of operation are for the latest versions of the control boards (521696.3, 521696.2 and 521696.1 Rev72). The older version of the control has the following differences:

- The older control does not have slush mode with a continuous drive
- The older control does not have a consistency check during the pre stir in slush mode and the pre stir is 3 seconds (instead of 4)
- The older control runs strictly on timers during an error mode, and the cycle time during a drive motor error is 7 minutes off/55 seconds on.

NOTE

Slush mode has two options: normal and continuous drive. With the continuous drive option selected, the drive motor will run at all times, including standby. To change the control between the two options, refer to Section 4.3.

A. PRE STIR

When the CLEAN-OFF-ON is moved into the ON position or when the spigot is opened, the drive motor will start a 4-second pre stir. In slush mode, a consistency check will determine if a freezing cycle will begin.

B. FREEZING CYCLE

After the pre stir, a freezing cycle begins. The freezing cycle continues until the torque rod closes the torque switch and keeps the switch closed for 3 seconds. If

product consistency is not met within 22 minutes for slush or 20 minutes for shake, the machine will operate in the compressor time out mode (See Section 1.4).

NOTE

If the spigot is pulled during a freezing cycle, the 20-minute or 22-minute timer will restart.

C. POST STIR

After the freezing cycle ends, the drive motor will continue to run for an 18 second post stir. The post stir ensures the product does not freeze to the cylinder. If the spigot is opened during the post stir, the machine will check consistency. If the product is at consistency, the machine will move into standby. If the product is not at consistency, the machine will start a freezing cycle.

D. STANDBY

After the post stir, the machine will be in standby. It will remain in standby for 7 minutes or until the spigot is opened.

E. DEFROST MODE (SLUSH MODE ONLY)

If the spigot is not opened for 3 hours, defrost mode will begin. The drive motor will run for 90 seconds every 7 minutes and the diagnostic light will remain lit.

After 5.5 hours or if the spigot is opened, normal operation mode will begin.

F. CLEAN MODE

When the CLEAN-OFF-ON switch is in the CLEAN position, the drive motor starts and will run for 20 minutes. After the 20 minutes expire, the drive motor will stop and the diagnostic light will flash three times every 4 seconds. It will continue to flash until the CLEAN-OFF-ON switch is moved out of the CLEAN position.

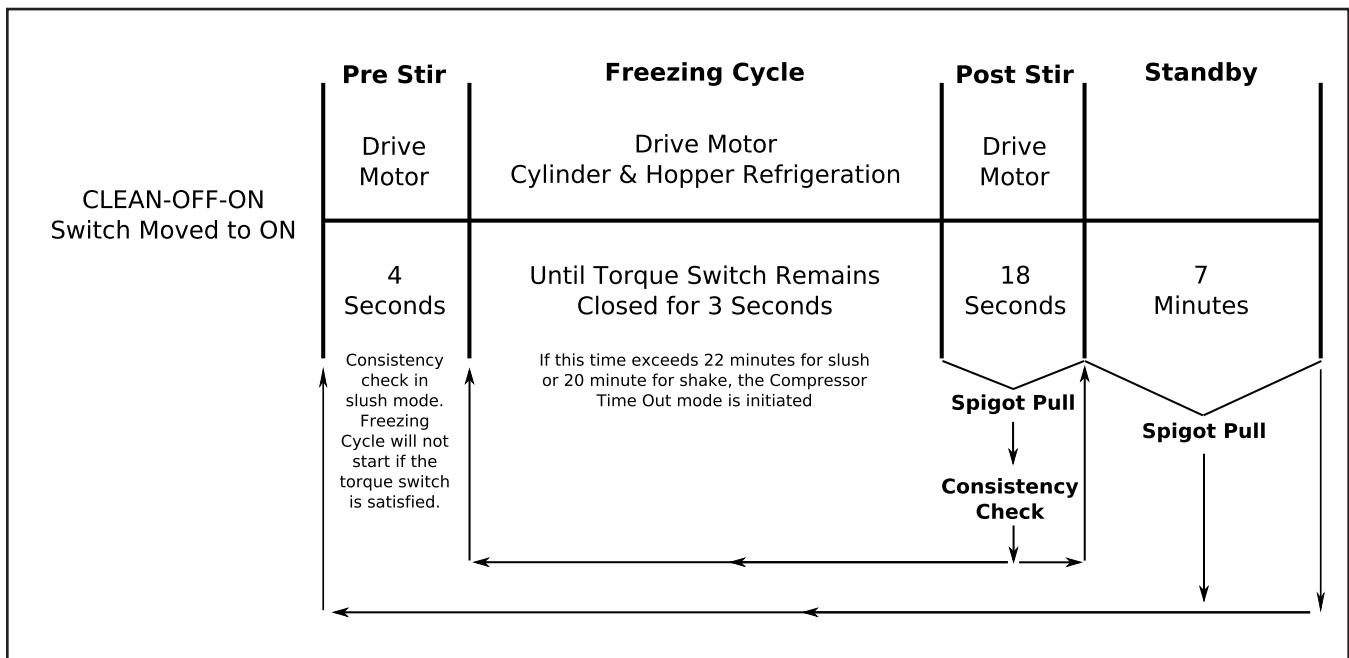

Figure 1-3 Modes of Normal Operation

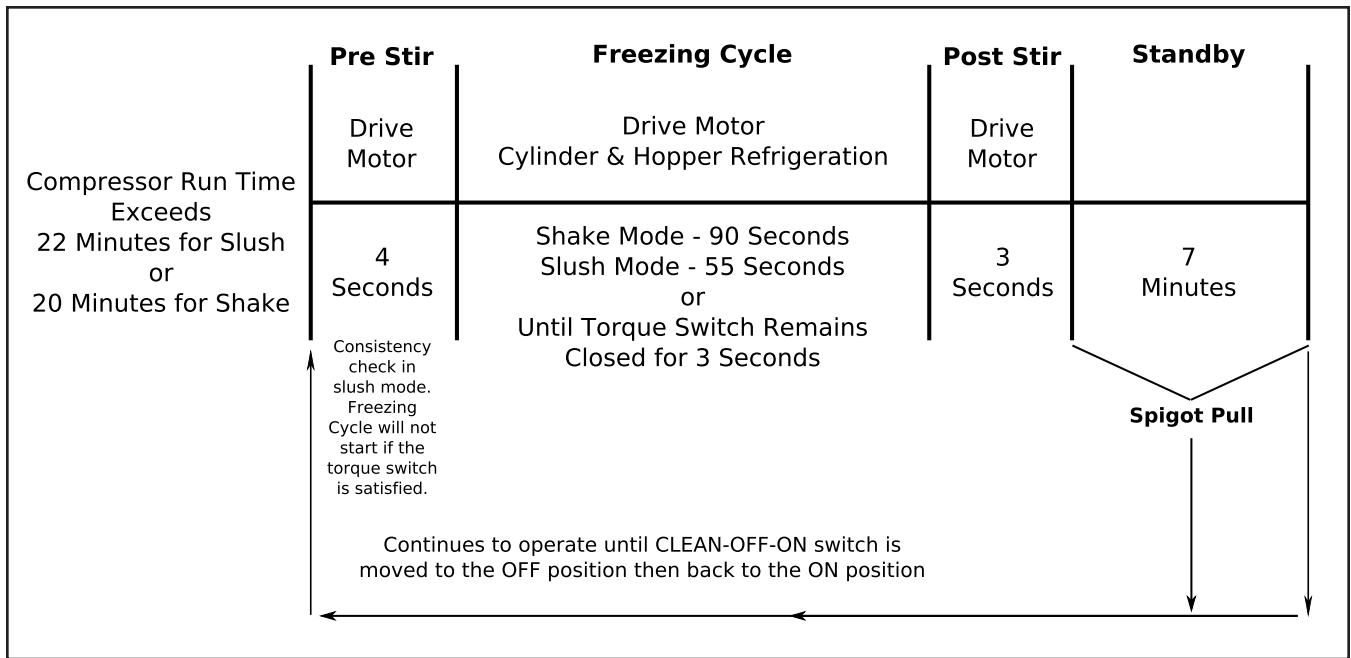

Figure 1-4 Compressor Time Out Mode

1.4 OPERATION DURING AN ERROR MODE

A. COMPRESSOR TIME OUT MODE

If the freezing cycle exceeds 20 minutes for shake or 22 minutes for slush, the machine will operate on timers. The diagnostic light will flash once every 4 seconds (Refer to Figure 1-4).

B. LOW MIX MODE

If the mix level falls below the sensor probe, the machine will operate on timers. The ADD MIX light will flash. The machine will continue to operate on timers until the mix level in the hopper is above the sensor probe (Refer to Figure 1-5).

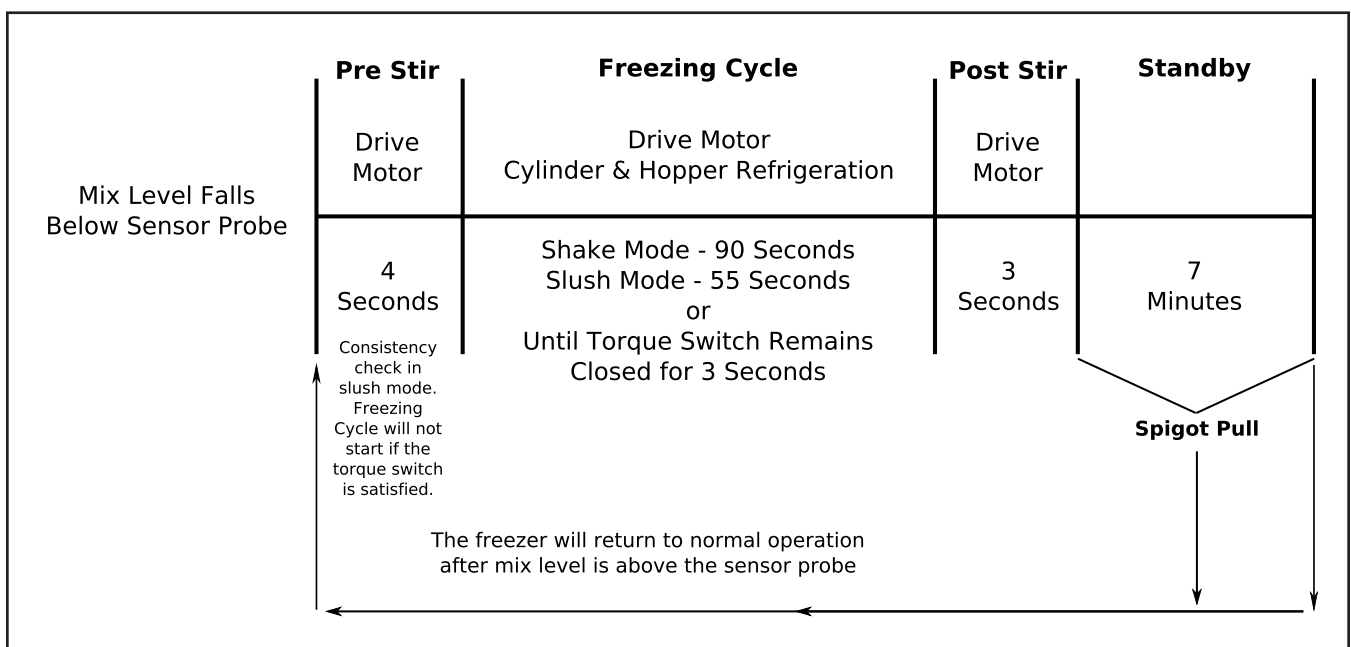

Figure 1-5 Low Mix Mode

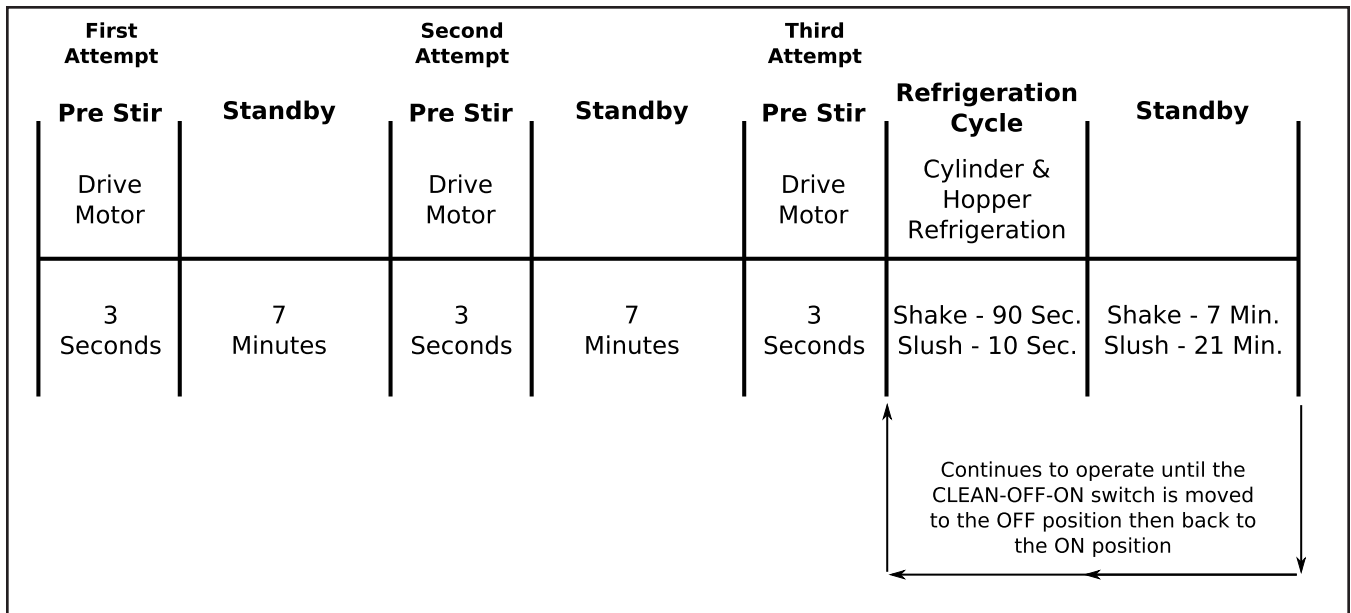

Figure 1-6 Drive Motor Error Mode

C. DRIVE MOTOR ERROR MODE

If the control does not sense current from the drive motor during a pre stir, the machine will go into standby mode for 7 minutes. After standby, the control will repeat the pre stir and attempt to sense drive motor current. After the third pre stir without sensing drive motor current, the machine will operate on timers and the diagnostic light will flash twice every four seconds (Refer to Figure 1-6). The attempts to sense the drive motor current can be substituted by pulling the spigot.

SECTION 2 INSTALLATION INSTRUCTIONS

2.1 SAFETY PRECAUTIONS

Do not attempt to operate the machine until the safety precautions and operating instructions in this manual are read completely and are thoroughly understood.

Take notice of all warning labels on the machine. The labels have been put there to help maintain a safe working environment. The labels have been designed to withstand washing and cleaning. All labels must remain legible for the life of the machine. Labels should be checked periodically to be sure they can be recognized as warning labels.

If danger, warning or caution labels are needed, indicate the part number, type of label, location of label, and quantity required along with your address and mail to:

STOELTING, INC.
ATTENTION: Customer Service
502 Hwy. 67
Kiel, Wisconsin 53042

2.2 SHIPMENT AND TRANSIT

The machine has been assembled, operated and inspected at the factory. Upon arrival at the final destination, the entire machine must be checked for any damage which may have occurred during transit.

With the method of packaging used, the machine should arrive in excellent condition. **THE CARRIER IS RESPONSIBLE FOR ALL DAMAGE IN TRANSIT, WHETHER VISIBLE OR CONCEALED.** Do not pay the freight bill until the machine has been checked for damage. Have the carrier note any visible damage on the freight bill. If concealed damage and/or shortage is found later, advise the carrier within 10 days and request inspection. The customer must place claim for damages and/or shortages in shipment with the carrier. Stoelting, Inc. cannot make any claims against the carrier.

2.3 MACHINE INSTALLATION

Installation of the machine involves moving the machine close to its permanent location, removing all crating, setting in place, assembling parts, and cleaning.

- A. Uncrate the machine.
- B. Accurate leveling is necessary for correct drainage of machine barrel and to insure correct overrun. Place a bubble level on top of the machine at each corner to check for level condition. If adjustment is necessary, level the machine by turning the bottom part of each leg in or out.
- C. The F112 has a base gasket that must be installed. Separate the gasket and install it with the seam to the back. Make sure the angled side of the gasket is facing up.



Figure 2-2 Space and Ventilation Requirements

- D. Correct ventilation is required. The E112 requires 3" clearance on both sides. If the machine is placed side-by-side next to other equipment, there needs to be at least 4" clearance at the back of the machine. The air-cooled F112 requires 6" clearance on both sides for proper air flow.

CAUTION

Failure to provide adequate ventilation will void warranty.

- D. Connect the drip tray bracket by loosening the two screws at the front of the machine. Install the bracket so that it rests on the nylon washer between the two metal washers. Tighten the screws.



Figure 2-3 Drip Tray Bracket

- E. Place the CLEAN-ON-OFF switch in the OFF position.

**WARNING**

Do not alter or deform electrical plug in any way. Altering the plug to fit into an outlet of different configuration may cause fire, risk of electrical shock, product damage and will void warranty.

- E. Connect the power cord to the proper power supply. The plug on the E112 is designed for 115VAC, 20 amp duty and the plug on the F112 is designed for 208-240VAC / 15 amp duty. Check the nameplate on your machine for proper supply. The unit must be connected to a properly grounded receptacle. The electrical cord furnished as part of the machine has a three prong grounding type plug. The use of an extension cord is not recommended, if necessary use one with a size 12 gauge or heavier with ground wire. Do not use an adapter to get around grounding requirement.

SECTION 3 INITIAL SET-UP AND OPERATION

3.1 OPERATOR'S SAFETY PRECAUTIONS

SAFE OPERATION IS NO ACCIDENT; observe these rules:

- A. Know the machine. Read and understand the Operating Instructions.
- B. Notice all warning labels on the machine.
- C. Wear proper clothing. Avoid loose fitting garments, and remove watches, rings or jewelry that could cause a serious accident.
- D. Maintain a clean work area. Avoid accidents by cleaning up the area and keeping it clean.
- E. Stay alert at all times. Know which switch, push button or control you are about to use and what effect it is going to have.
- F. Disconnect electrical cord for maintenance. Never attempt to repair or perform maintenance on the machine until the main electrical power has been disconnected.
- G. Do not operate under unsafe operating conditions. Never operate the machine if unusual or excessive noise or vibration occurs.

3.2 OPERATING CONTROLS AND INDICATORS

Before operating the machine, it is required that the operator know the function of each operating control. Refer to Figure 3-1 for the location of the operating controls on the machine.

WARNING

High voltage will shock, burn or cause death. The OFF-ON switch must be placed in the OFF position prior to disassembling for cleaning or servicing. Do not operate machine with cabinet panels removed.

A. Spigot Switch

The spigot switch will automatically start the auger drive and refrigeration systems when the spigot is opened to dispense product. When the spigot is closed, the drive motor and compressor will remain on until the product in the freezing cylinder reaches the proper consistency..



Figure 3-1 Controls

B. CLEAN-OFF-ON Switch

The CLEAN-OFF-ON switch is used to supply power to the control circuit. When the switch is in the OFF (middle) position, power will not be supplied to the control board or refrigeration system. When the switch is in the ON position, the machine will operate in the freezing mode. When the switch is in the CLEAN position, all refrigeration will stop and the auger will start rotating.

C. ADD MIX Light

The ADD MIX light will flash to alert the operator to a low mix condition. It does so by monitoring the mix level in the hopper. When the ADD MIX light is flashing, refill hopper immediately.

NOTE

Failure to refill hopper immediately may result in operational problems.

D. Diagnostic Light

The Diagnostic Light will flash if an error occurs. The light will flash once if there is a compressor error. There will be two quick flashes if there is an auger error. And there will be three quick flashes if the machine is left in clean mode for more than 20 minutes. Refer to the troubleshooting section for details.

E. Consistency Adjustment Screw

The Consistency Adjustment Screw increases or decreases product consistency. A tension spring is connected to the screw and changes the amount of torque needed to complete a refrigeration cycle. Turn the knob clockwise to increase consistency or counterclockwise to decrease consistency.

NOTE

An additional spring is included with the machine behind the header panel. The additional spring can be installed for use with shake mixes when a higher consistency is required. Do not use the optional spring with slush mixes.

F. Front Door Safety Switch

The front door safety switch prevents the auger from turning when the front door is removed. The switch is open when the door is not in place and closed when the door is properly installed.

G. Autofill Kit - Optional (E112 Part 2183807, F112 Part 2187101)

The autofill kit is used with a pump to keep the hopper filled. The autofill kit is for use with non-potentially hazardous food substances; non-dairy. Refer to Section 5-4 for Autofill options.

H. Light Kit - Optional (E112 Part 2183800, F112 Part 2187102)

The light kit is installed behind the header panel and illuminates a translucent header panel.

I. Bottle Rack Kit - Optional (E112 Part 2187100, F112 Part 2187040 or 2187024)

The bottle rack kit is installed onto the header panel and holds 7 flavor bottles (13 bottles on the 2187024).

J. Spinner Kit - Optional (E112 Part 2187103, F112 Part 2187031)

The spinner kit is installed on the front of the machine and offers blended frozen beverages.

3.3 SANITIZING

Sanitizing must be done after the machine is cleaned and just before the hopper is filled with mix. Sanitizing the night before is not effective. However, you should always clean the machine and parts after each use.

The United States Department of Agriculture and the Food and Drug Administration require that all cleaning and sanitizing solutions used with food processing equipment be certified for this use.

When sanitizing the machine, refer to local sanitary regulations for applicable codes and recommended sanitizing products and procedures. The frequency of sanitizing must comply with local health regulations.

Mix sanitizer according to manufacturer's instructions to provide a 100 parts per million (ppm) strength solution and check the solution with chlorine test strips. Mix sanitizer in quantities of no less than 2 gallons (7.5 liters) of 90° to 110°F (32° to 43°C) water. Allow sanitizer to contact the surfaces to be sanitized for 5 minutes. Any sanitizer must be used only in accordance with the manufacturer's instructions.

CAUTION

Do not allow sanitizer to remain in contact with stainless steel parts for prolonged periods. Prolonged contact of sanitizer with machine may cause corrosion of stainless steel parts.

In general, sanitizing may be conducted as follows:

- A. Prepare Stera-Sheen Green Label Sanitizer or equivalent according to manufacturer's instructions to provide a 100 ppm strength solution. Mix the sanitizer in quantities of no less than 2 gallons of 90° to 110°F (32° to 43°C) water. Check the strength of the sanitizing solution. Use a chlorine test strip and color chart to make sure the solution has 100 ppm. Any sanitizer must be used only in accordance with the manufacturer's instructions.

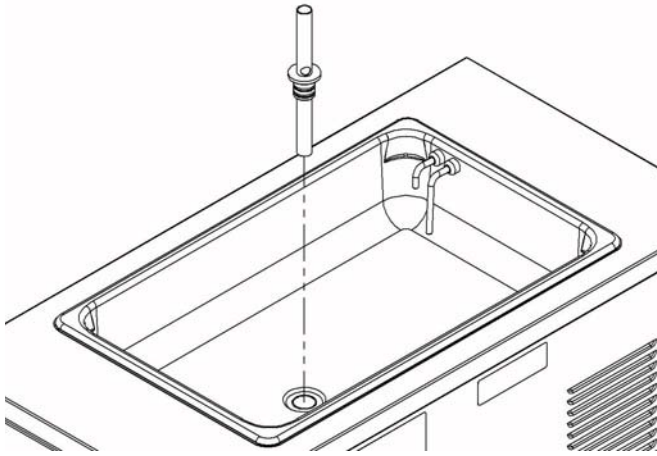

Figure 3-2 Mix Inlet Regulator

- B. If using a shake mix, place the mix inlet regulator into hopper (Refer to Figure 3-2). If using a slush mix, the mix inlet regulator is not required.
- C. Pour the sanitizing solution into the hopper and place the switch in the CLEAN position. Check for leaks.
- D. Clean sides of hopper, mix inlet regulator and underside of hopper cover using a soft bristle brush dipped in the sanitizing solution (Refer to Figure 3-3).



Figure 3-3 Sanitizing hopper

- E. After five minutes, place a bucket under the spigot and open spigot to drain most sanitizing solution. Leave a small amount of the sanitizing solution in the freezing cylinder. Place the switch in the OFF (middle) position.
- F. Collect the remaining sanitizing solution in a cup and test the chlorine contents with a new test strip. A reading of 100 ppm or more is acceptable.
If the reading is less than 100 ppm, sanitize the machine again.
If the reading is less than 100 ppm after sanitizing the second time, disassemble and wash the machine again.

3.4 FREEZE DOWN AND OPERATION

This section covers the recommended operating procedures for the safe operation of the machine.

- A. Sanitize just prior to use.
- B. Place the switch in the OFF (middle) position.

NOTE

Make sure the mix inlet regulator is in place before adding shake mixes. This is not necessary for slush mixes.

- C. Pour approximately 1/2 gallon of fully thawed mix into the hopper. Open spigot and drain a small amount of mix to remove any remaining sanitizer.
- D. Fill the hopper with pre-chilled (40°F or 4°C) mix.

NOTE

Do not overfill the hopper. Mix level must be below the air inlet tube on the mix inlet regulator.

- E. Place the switch in the ON position.

NOTE

After the drive motor starts, there is a 3 or 4 second delay before the compressor starts.

- F. After 8 to 12 minutes the product will be at consistency and will be ready to serve. Freeze down time may vary depending on mix type and ambient temperatures.
- G. To dispense, pull the spigot handle down to open the spigot.
- H. The machine is designed to dispense the product at a reasonable draw rate. If the machine is overdrawn, the result is a soft product or a product that will not dispense at all. If this should occur, allow the machine to run for approximately 30 seconds before dispensing additional product.
- I. Do not operate the machine when the ADD MIX light is on. Refill the hopper immediately.

3.5 MIX INFORMATION

Mix can vary considerably from one manufacturer to another. Differences in the amount of butterfat content and quantity and quality of other ingredients have a direct bearing on the finished frozen product. A change in machine performance that cannot be explained by a technical problem may be related to the mix.

Proper product serving temperature varies from one manufacturer's mix to another. Shake and stackable slush mixes provide satisfactory product from 24° to 28°F (-4° to -2°C).

When checking the temperature, stir the thermometer in the frozen product to obtain an accurate reading.

Old mix or mix that has been stored at elevated temperatures will produce poor-quality product with a bad taste and unacceptable appearance. To retard bacteria growth in dairy based mixes, the best storage temperature range is between 33° to 38°F (0.5° to 3.3°C).

Some shake mixes tend to foam more than others. If foam appears in the hopper, skim off with a sanitized utensil and discard. Periodically, stir the mix in the hopper with a sanitized utensil to help prevent excess foam.

3.6 REMOVING MIX FROM MACHINE

To remove the mix from the machine, refer to the following steps:

- A. If removing shake mix, pull the mix inlet regulator straight up and remove it from the hopper.
- B. Place the switch in the CLEAN position to rotate the auger. Allow the mix to agitate in freezing cylinder until the mix has become liquid, about 5 minutes.
- C. Drain the liquid mix by opening the spigot. A container should be placed under the spigot to collect the liquid mix.
- D. Place the switch in the OFF (middle) position.

3.7 CLEANING THE MACHINE

NOTE

The frequency of cleaning the machine and machine parts must comply with local health regulations.

After the mix has been removed from the machine, the machine must be cleaned. To clean the machine, refer to the following steps:

- A. Close the spigot and fill the hopper with 2 gallons (8 liters) of tap water.
- B. Place the switch in the CLEAN position. The auger will start to rotate.
- C. Allow the water to agitate for approximately 30 seconds.
- D. Open the spigot to drain the water. Remember to place a container under the spigot to catch the water. When the water has drained, place the switch in the OFF (middle) position. Allow the freezing cylinder to drain completely.
- E. Prepare sanitizing solution according to manufacturer's instructions to provide a 100 ppm strength solution. Mix the sanitizer in quantities of no less than 2 gallons of 90° to 110°F (32° to 43°C) water. Check the strength of the sanitizing solution. Use a chlorine test strip and color chart to make sure the solution has 100 ppm. Repeat steps A through D using the sanitizing solution.

3.8 DISASSEMBLY OF MACHINE PARTS

Inspection for worn or broken parts should be made each time the machine is disassembled. All worn or broken parts should be replaced to ensure safety to both the operator and the customer and to maintain good machine performance and a quality product. Frequency of cleaning must comply with the local health regulations.

To disassemble the machine, refer to the following steps:

 CAUTION
Hazardous Moving Parts. Revolving auger shaft can grab and cause injury. Place the switch in the OFF (middle) position before disassembling for cleaning or servicing.

- A. Remove hopper cover. Remove the mix inlet regulator from the hopper (if installed).
- B. Pull out the spigot pin by its ring (Refer to Figure 3-4).

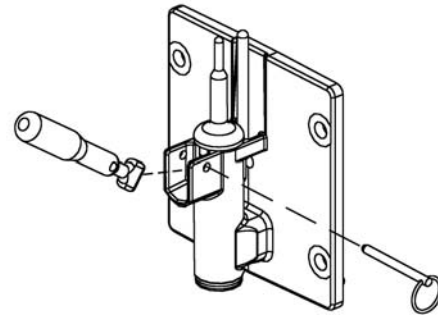

Figure 3-4 Remove Spigot Pin

- C. Remove the spigot handle.
- D. Remove front door by turning the circular knobs and then pulling door off the studs.

NOTE

When removing front door, entire door and stator assembly will come out as well.

- E. Remove torque rod from stator assembly.
- F. Remove quad ring from groove in front door.
- G. Remove stator bar. Remove o-ring and white bushing from stator bar.
- H. Remove auger support bushing.
- I. Turn the spigot body until the ice breaker bar can be removed. Remove breaker bar (Refer to Figure 3-5).

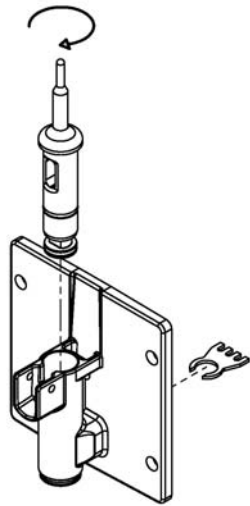

Figure 3-5 Spigot and Ice Breaker Bar Removal

- J. Remove spigot body from the front door.
- K. Remove o-rings (2) from the spigot by first wiping off the lubricant using a clean paper towel. Then squeeze the o-ring upward with a dry cloth. When a loop is formed, roll the o-ring out of the groove (Refer to Figure 3-6).
- L. Remove auger assembly from the freezing cylinder and remove auger blades.
- M. Remove rear seal and o-ring from auger.
- N. Remove drain tray, drip tray and drip tray grid.



Figure 3-6 Removing O-Ring

3.9 CLEANING AND SANITIZING THE MACHINE PARTS

Place all loose parts in a pan or container and take to the wash sink for cleaning. Local and state health codes dictate the procedure required. Some health codes require a four-sink process (pre-wash, wash, rinse, sanitize, and air-dry), while other codes require a three-sink process (without the pre-wash step). The following procedures are a general guideline only. Consult your local and state health codes for procedures required in your location.



Figure 3-7 Cleaning Freezing Cylinder

- A. Prepare Stera-Sheen or equivalent cleaner in 2 gallons of 90° to 110°F (32° to 43°C) water following manufacturers instructions.
- B. Prepare sanitizing solution according to manufacturer's instructions to provide a 100 ppm strength solution. Mix the sanitizer in quantities of no less than 2 gallons of 90° to 110°F (32° to 43°C) water. Check the strength of the sanitizing solution. Use a chlorine test strip and color chart to make sure the solution has 100 ppm.
- D. Place all parts in the cleaning solution and clean the parts with the provided brushes. Rinse all parts with clean 90° to 110°F (32° to 43°C) water. Place the parts in the sanitizing solution.
- E. Wash the hopper and freezing cylinder with the 90° to 110°F (32° to 43°C) cleaning solution and brushes provided (Refer to Figure 3-7).
- F. Clean the rear seal surfaces from the inside of the freezing cylinder with the 90° to 110°F (32° to 43°C) cleaning solution.

3.10 SANITIZE MACHINE

CAUTION

Do not allow sanitizer to remain in contact with stainless steel parts for prolonged periods. Prolonged contact of sanitizer with machine may cause corrosion of stainless steel parts.

- A. Use Stera-Sheen or equivalent sanitizing solution mixed according to manufacturer's instructions to provide 100 parts per million strength solution. Mix sanitizer in quantities of no less than 2 gallons (7.5 liters) of 90° to 110°F (32° to 43°C) water. Any sanitizer must be used only in accordance with the manufacturer's instructions.

- B. With the large brush provided, sanitize the rear of the freezing cylinder by dipping the brush in the sanitizing solution and brushing the rear of the cylinder.

3.11 ASSEMBLY OF MACHINE

To assemble the machine parts, refer to the following steps:

NOTE

Petrol Gel sanitary lubricant or equivalent must be used when lubrication of parts is specified.

NOTE

The United States Department of Agriculture and the Food and Drug Administration require that lubricants used on food processing equipment be certified for this use. Use lubricants only in accordance with the manufacturer's instructions.

- A. Assemble all o-rings onto the parts dry, without lubrication. Then apply a thin film of sanitary lubrication to the exposed surfaces of the o-rings. Also apply a thin film of sanitary lubricant to the inside and outside of the front auger support bushing, and to the inside and outside of stator support bushing.
- B. Assemble the rear seal onto the auger with the large end to the rear. Be sure the o-ring is in place before installing the rear seal (Refer to Figure 3-8).
- C. Put a small amount of spline lubricant on the hex end of the auger shaft. A small container of spline lubricant is shipped with the machine.

- D. Install the plastic auger blade onto the auger.
- E. Push the auger into the freezing cylinder and rotate it slowly until the auger engages the drive shaft.
- F. Insert the spigot body into the front door.

NOTE

Press the o-rings against the spigot body when inserting it into the front door to prevent damage.

- G. Turn the spigot body until the ice breaker bar can be inserted. Insert the breaker bar and rotate the spigot body 90°.
- H. Install the auger support bushing onto the front door so the beveled edge of the bushing is against the door.
- I. Install the white stator support bushing onto the rear of the stator bar and insert stator into spigot.
- J. Insert the torque rod. The rod should be placed through the hole in the stator bar.
- K. Install the front door onto the machine.

NOTE

When installing the door onto the machine, the torque rod must be placed in the center of the metal torque actuator arm

- L. Install the knobs on the machine studs.
- M. Look for the proper seal between the freezing cylinder, quad ring, and front door

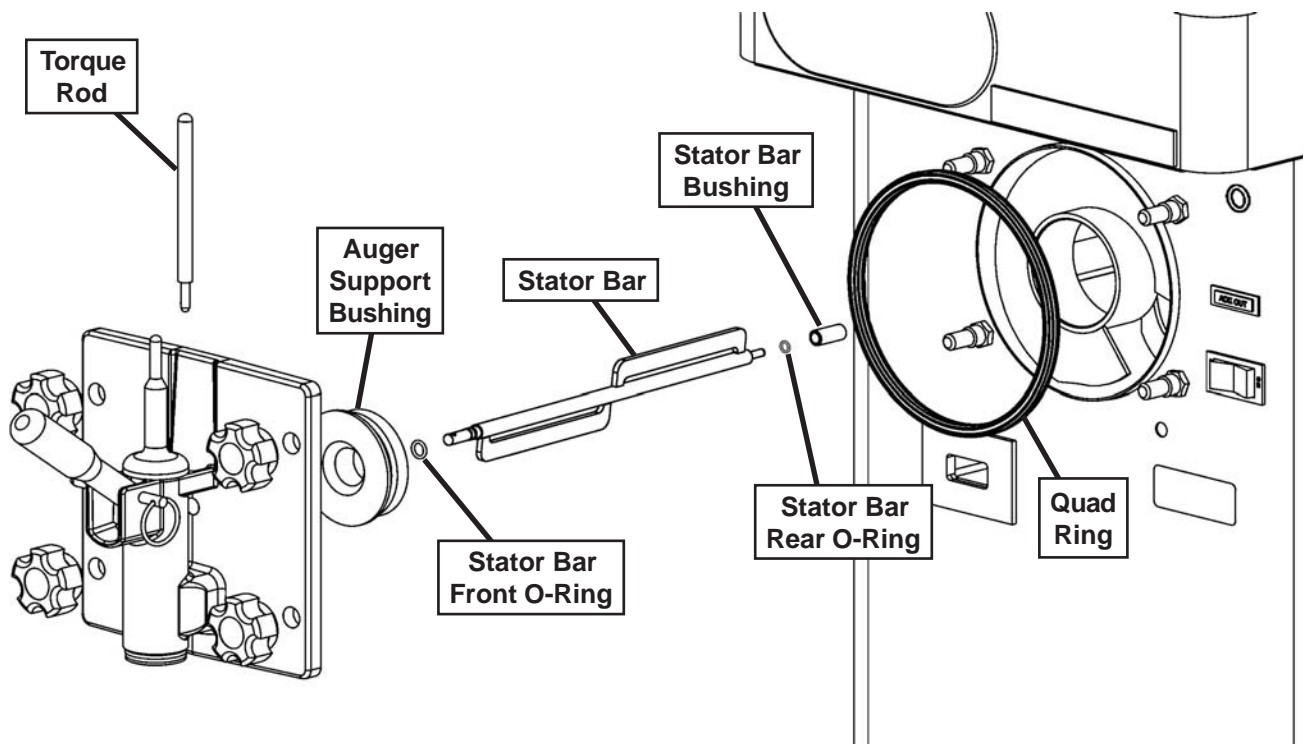

Figure 3-9 Door and Stator Assembly

CAUTION

Do not place the mix inlet regulator into the hopper before installing the auger. Attempting to install the auger with the mix inlet regulator in place will damage the regulator.

- N. Insert the spigot handle so the hole lines up and insert the spigot pin.
- O. Install the mix inlet regulator into the hopper if using shake mix. If using slush mix, the mix inlet regulator is not required.
- P. Install the hopper cover, drain tray, drip tray, and drip tray grid.

3.12 ROUTINE CLEANING

To remove spilled or dried mix from the machine exterior, wash in the direction of the finish with warm soapy water and wipe dry. Do not use highly abrasive materials as they will mar the finish.

3.13 PREVENTIVE MAINTENANCE

Stoelting recommends that a maintenance schedule be followed to keep the machine clean and operating properly.

CLEANING AND SANITIZING INFORMATION

Special consideration is required when it comes to food safety and proper cleaning and sanitizing.

The following information has been compiled by Purdy Products Company, makers of Stera-Sheen Green Label Cleaner/Sanitizer and specifically covers issues for cleaning and sanitizing frozen dessert machines. This information is meant to supplement a comprehensive food safety program.

SOIL MATERIALS ASSOCIATED WITH FROZEN DESSERT MACHINES

MILKFAT/BUTTERFAT – As components of ice-cream/frozen custard mix, these soils will accumulate on the interior surfaces of the machine and its parts. Fats are difficult to remove and help attribute to milkstone build-up.

MILKSTONE – Is a white/gray film that forms on equipment and utensils that come in contact with dairy products. These films will accumulate slowly on surfaces because of ineffective cleaning, use of hard water, or both. Milkstone is usually a porous deposit, which will harbor microbial contaminants and eventually defy sanitizing efforts.

Once milkstone has formed, it is very difficult to remove. Without using the correct product and procedure, it is nearly impossible to remove a thick layer of milkstone. (NOTE: general-purpose cleaners DO NOT remove milkstone.) This can lead to high bacteria counts and a food safety dilemma.

IT IS BEST TO CONTROL MILKSTONE ON A DAILY BASIS BEFORE IT CAN BECOME A SIGNIFICANT FOOD SAFETY PROBLEM.

In addition to food safety, milkstone can cause premature wear to machine parts which can add to costs for replacement parts or possibly more expensive repairs if worn machine parts are not replaced once they have become excessively worn.

IMPORTANT DIFFERENCES BETWEEN CLEANING AND SANITIZING

CLEANING vs. SANITIZING

It is important to distinguish between cleaning and sanitizing. Although these terms may sound synonymous, they are not. BOTH are required for adequate food safety and proper machine maintenance.

CLEANING

- Is the removal of soil materials from a surface.
- Is a prerequisite for effective sanitizing.

NOTE

An UNCLEAN surface will harbor bacteria that can defy sanitizing efforts.

Bacteria can develop and resist sanitizing efforts within a layer of soil material (milkstone). Thorough cleaning procedures that involve milkstone removal are critical for operators of frozen dessert machines.

SANITIZING

- Kills bacteria.
- Can be effective on clean surfaces only.

NOTE

Using a SANITIZER on an unclean surface will not guarantee a clean and safe frozen dessert machine.

PROPER DAILY MAINTENANCE: THE ONLY WAY TO ASSURE FOOD SAFETY AND PRODUCT QUALITY

Proper daily maintenance can involve a wide variety of products and procedures. Overall, the products and procedures fall into three separate categories. (Please note that this is a brief overview intended for informational purposes only.)

1. **CLEANING** – This involves draining mix from the freezing cylinder and rinsing the machine with water. Next, a cleaner is run through the machine. Then, the machine is disassembled and removable parts are taken to the sink for cleaning.
2. **MILKSTONE REMOVAL** – Since almost all cleaners do not have the ability to remove milkstone, the use of a delimer becomes necessary. Although this procedure may not be needed on a daily basis, it will usually follow the cleaning procedure. It requires letting a delimer solution soak in the machine for an extended period of time. Individual parts are also soaked in a deliming solution for an extended period of time (more about delimers in Additional Information).

3. **SANITIZING** – After the machine has been cleaned and contains no milkstone, the machine is reassembled. Then a FDA-approved sanitizing solution is run through the machine to kill bacteria. The machine is then ready for food preparation.

As a recommended cleaner and sanitizer for your frozen dessert machine, STERA-SHEEN has proven to be one of the best daily maintenance products for:

- **CLEANING** – Thorough removal of all solids including butterfat and milk fat.
- **MILKSTONE REMOVAL** – Complete removal of milkstone.
- **SANITIZING** – FDA-approved no rinse sanitizer for food contact surfaces.

ADDITIONAL INFORMATION

THE USE OF DELIMERS

A delimer is a strong acid that has the ability to dissolve milkstone. This type of chemical may become necessary once high levels of milkstone have developed. While these products are very effective for removing HIGH levels of milkstone, they are not ideal for two reasons:

1. **PRODUCT SAFETY** – Strong acids are dangerous chemicals and handling them requires safety
2. **MACHINE DAMAGE** – Strong acids will attack metal and rubber causing premature wear of parts. The use of a delimer needs to be closely monitored to avoid damage to machine surfaces and parts.

With proper daily use of STERA-SHEEN or its equivalent, there is no need for the use of a DELIMER.

DO NOT USE BLEACH

- **BLEACH HAS ABSOLUTELY NO CLEANING PROPERTIES.**
- **BLEACH IS CORROSIVE.** It can and will damage components of the machine causing premature wear and metal corrosion.

GENERAL PURPOSE CLEANERS

General purpose cleaners do not have the ability to remove milkstone. Milkstone will become a problem if not remedied with additional products and procedures.

THE USE OF CHLORINE TEST STRIPS

“Test strips” are used to determine concentrations of active chlorine in sanitizing solutions. To use the strips, tear off a small portion and submerge it into the sanitizing solution. Then, compare the color change to the color key on the side of the test strip dispenser to determine the approximate chlorine concentration.

The ideal concentration of chlorine needs to be 100 ppm (as stated by the FDA).

NOTE

Follow the directions on the container for proper concentration.

There are two main factors that contribute to falling chlorine concentrations in a sanitizing solution.

1. **PRODUCT USE** – As the chlorine in the solution is being used, chlorine concentrations fall.
2. **TIME** – As time passes, small amounts of chlorine “evaporate” from the solution. (That is why you can smell it.)

Sanitizing solutions should not be allowed to fall below 100 ppm chlorine. New solutions should be mixed once old solutions become ineffective

B. DAILY

1. The exterior should be kept clean at all times to preserve the luster of the stainless steel. A mild alkaline cleaner is recommended. Use a soft cloth or sponge to apply the cleaner.

C. WEEKLY

1. Check o-rings and rear seal for excessive wear and replace if necessary.
2. Remove the drip tray by gently lifting up to disengage from the support and pulling out. Clean behind the drip tray and front of the machine with a soap solution.

D. QUARTERLY

Air Cooled

The air-cooled condenser is a copper tube and aluminum fin type. Condensing is totally dependent upon airflow. A plugged condenser filter, condenser, or restrictions in the louvered panel will restrict airflow. This will lower the capacity of the system and damage the compressor.

The condenser must be kept clean of dirt and grease. The F112 must have a minimum of 6” (15.2 cm) ventilation on the right and left sides of the unit for free flow of air. The E112 must have 3” (7.6 cm) ventilation. Make sure the machine is not pulling over 100° F (37° C) air from other equipment in the area.

The condenser and condenser filter require periodic cleaning. To clean, refer to the following procedures.

E112 Air Cooled Condenser Cleaning

- A. Unscrew the knob located on the underside of the machine towards the front (Fig. 3-10).
- B. Remove the filter bracket and remove the filter.
- C. Visually inspect the condenser filter for dirt.
- D. If the filter is dirty, vacuum or brush clean, rinse with clean water and allow to dry before replacing on the machine.

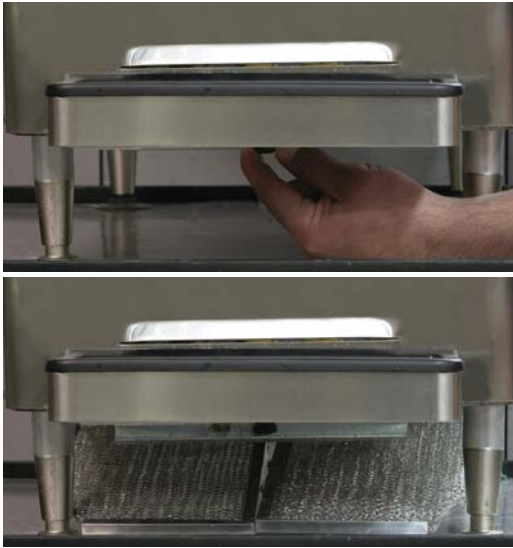

Figure 3-10 E112 Condenser Filter Removal

NOTE

If the condenser is not kept clean, refrigeration efficiency will be lost.

F112 Air Cooled Condenser Cleaning

- A. Remove the Phillips head screws from the bottom of the right side panel, and then slide the panel down and out.
- B. To remove the condenser filter, grasp the top and pull off. Visually inspect it for dirt. If the filter is dirty, shake or brush excess dirt off the filter and wash it in warm, soapy water. Once the filter is clean rinse thoroughly in warm, clear water and shake dry, taking care not to damage the filter in any way (Fig. 3-11).



Figure 3-11 F112 Condenser Filter Removal

- C. Visually inspect the condenser for dirt by shining a light through the coil from the back (inside) of the condenser.
- D. If the condenser is dirty, place a wet towel over the front (outside) of the condenser.
- E. Using a vacuum, carefully clean the condenser coil from the inside and outside of the machine. A stiff bristled brush may help in releasing debris from between the condenser coils.

Water Cooled (F112 only)

The water-cooled condenser is a tube and shell type. The condenser needs a cool, clean supply of water to properly cool the machine. Inlet and discharge lines must be 3/8" I.D. minimum. Make sure the machine is receiving an unrestricted supply of cold, clean water.

E. SEMI-ANNUALLY

1. Disconnect the machine from the power source.
2. Use a Burroughs Belt Tension Gauge to set the tension for the drive belt. Set the belt tension on the E112 to 5-15 lbs and on the F112 to 30-40 lbs.
3. Lubricate the condenser fan motor with S.A.E. 20 weight oil. Three to six drops are required.

3.14 EXTENDED STORAGE

Refer to the following steps for storage of the machine over any long period of shutdown time:

- A. Place the CLEAN-OFF-ON switch in the OFF (middle) position.
- B. Disconnect (unplug) from the electrical supply source.
- C. Clean all parts that come in contact with mix thoroughly with a warm water cleaning solution. Rinse in clean water and dry parts. Do not sanitize.

NOTE

Do not let the cleaning solution stand in the hopper or in the freezing cylinder during the shutdown period.

- D. Remove, disassemble and clean the front door, mix inlet regulator and auger parts.
- E. In a water cooled machine, disconnect the water lines and drain water. With a flathead screwdriver, hold the water valve open and use compressed air to clear the lines of any remaining water.

SECTION 4 MAINTENANCE AND ADJUSTMENTS

4.1 MACHINE ADJUSTMENT

This section is intended to provide maintenance personnel with a general understanding of the machine adjustments. It is recommended that any adjustments in this section be made by a qualified person.

4.2 PRODUCT CONSISTENCY ADJUSTMENT

The Consistency Adjustment Knob increases or decreases product consistency by changing the amount of torque needed to complete a refrigeration cycle. Turn the knob clockwise to increase consistency.

TENSION SPRINGS

An optional spring is included with the machine and is for use with **shake mixes only**. It is located behind the header panel. To change springs, remove the header panel, unhook the original spring from the torque switch assembly and hook the new spring into place.

E112 - The standard spring is green. The optional spring is yellow.

F112 - The standard spring is yellow. The optional spring is red.

4.3 CONVERT SLUSH TO SHAKE

The machine is shipped from the factory for use with slush. To convert the machine for use with shake, locate the SHAKE/SLUSH terminal on the control board and remove the jumper (Fig. 4-1).

There are two jumpers for use in slush mode; a large jumper that has a resistor attached and a small jumper (shown below). The large jumper is used to run the drive motor continuously. The small jumper is used to run standby without the drive motor operating.

NOTE

The large jumper is only available on the [521696.3](#), [521696.2](#) and [521696.1 Rev72](#) control boards.



Figure 4-1 Shake to Slush Jumper

4.4 DRIVE BELT TENSION ADJUSTMENT

To check belt tension, refer to Figure 4-2 and follow the steps below:

- Remove the right side panel.
- Use a Burroughs Belt Tension Gauge to set the tension for the drive belt. Set the E112 belt tension to 5-15 lbs. Set the F112 belt tension to 20-30 lbs.
- If an adjustment is necessary, loosen the four motor plate retaining nuts, adjust belt tension then retighten the four nuts.

NOTE

Belt life will be increased if new drive belts are checked after two or three weeks of operation.

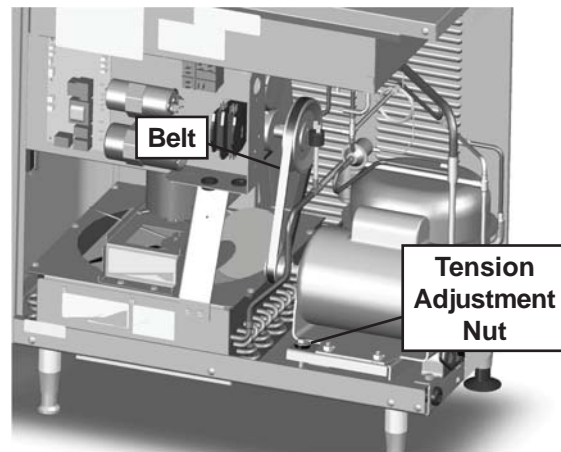

Figure 4-2 Belt Tension

4.5 CONDENSER CLEANING

The condenser requires periodic cleaning. To clean the condenser, refer to the following steps:

E112 CONDENSER

- Unscrew the knob located on the underside of the machine towards the front (Fig. 4-3).
- Remove the filter bracket and remove the filter.
- Visually inspect the condenser filter for dirt.
- If the filter is dirty, vacuum or brush clean, rinse with clean water and allow to dry before replacing on the machine.

NOTE

If the condenser is not kept clean, refrigeration efficiency will be lost.



Figure 4-3 E112 Condenser Filter Removal

F112 CONDENSER

- A. Remove the Phillips head screws from the bottom of the right side panel, and then slide the panel down and out.
- B. To remove the condenser filter, grasp the top and pull off. Visually inspect for dirt. If the filter is dirty, shake or brush excess dirt off the filter and wash in warm, soapy water. Once the filter is clean rinse thoroughly in warm, clear water and shake dry, taking care not to damage the filter in any way (Fig. 4-4).
- C. Visually inspect the condenser for dirt by shining a light through the coil from the back (inside) of the condenser.



Figure 4-4 F112 Condenser Filter Removal

- D. If the condenser is dirty, place a wet towel over the front (outside) of the condenser.
- E. Using a vacuum, carefully clean the condenser coil from the inside and outside of the machine. A stiff bristled brush may help in releasing debris from between the condenser coils.

4.6 PREVENTATIVE MAINTENANCE

It is recommended that a preventative maintenance schedule be followed to keep the machine clean and operating properly. The following steps are suggested as a preventative maintenance guide.

The United States department of agriculture and the food and drug administration require that lubricants used in food zones be certified for this use. Use lubricants only in accordance with the manufacturer's instructions.

- A. Daily checks
Check for any unusual noise or condition and repair immediately.
- B. Monthly checks
Check the condenser for dirt. (Refer to section 4.5).
- C. Quarterly checks
Check drive belts for wear and tighten belts if necessary. (Refer to section 4.4)

4.7 EXTENDED STORAGE

Refer to the following steps for storage of the machine over any long period of shutdown time:

- A. Place the CLEAN-OFF-ON switch in the OFF (middle) position.
- B. Disconnect (unplug) from the electrical supply source.
- C. Clean thoroughly with a warm water detergent all parts that come in contact with the mix. Rinse in clean water and dry parts. Do not sanitize.

NOTE

Do not let the cleaning solution stand in the hopper or in the freezing cylinder during the shutdown period.

- D. Remove, disassemble and clean the front door, mix inlet regulator and auger parts.
- E. In a water cooled machine, disconnect water lines and drain water. With a flathead screwdriver, hold the water valve open and use compressed air to clear the lines of any remaining water.

SECTION 5 REFRIGERATION SYSTEM

5.1 REFRIGERATION SYSTEM

The E112 and F112 refrigeration systems have two functions:

Medium-Temperature - Maintaining product temperature in the hopper.

Low-Temperature - Producing and maintaining high quality product in the freezing cylinder.

The system is designed for efficient use with R404A refrigerant. The proper charge is indicated on the information plate.

5.2 REFRIGERANT RECOVERY AND EVACUATION

Refer to the following procedures to properly recover and evacuate the refrigeration system. Do not purge refrigerant into the atmosphere.

NOTE

For qualified service personnel only. Anybody working with refrigerants must be certified as a Technician TYPE I as required by 40 CFR 82 Subpart F and hold all State and/or local refrigerant handling certifications. In addition, all handling, storage, and disposal of refrigerants must be in accordance with Environmental Protection Agency (EPA) guidelines and standards and all State and local guidelines and standards.



WARNING

Hazardous voltage

The CLEAN-OFF-ON switch must be placed in the OFF position when disassembling for servicing. The machine must be disconnected from electrical supply before removing any access panel. Failure to disconnect power before servicing could result in death or serious injury.

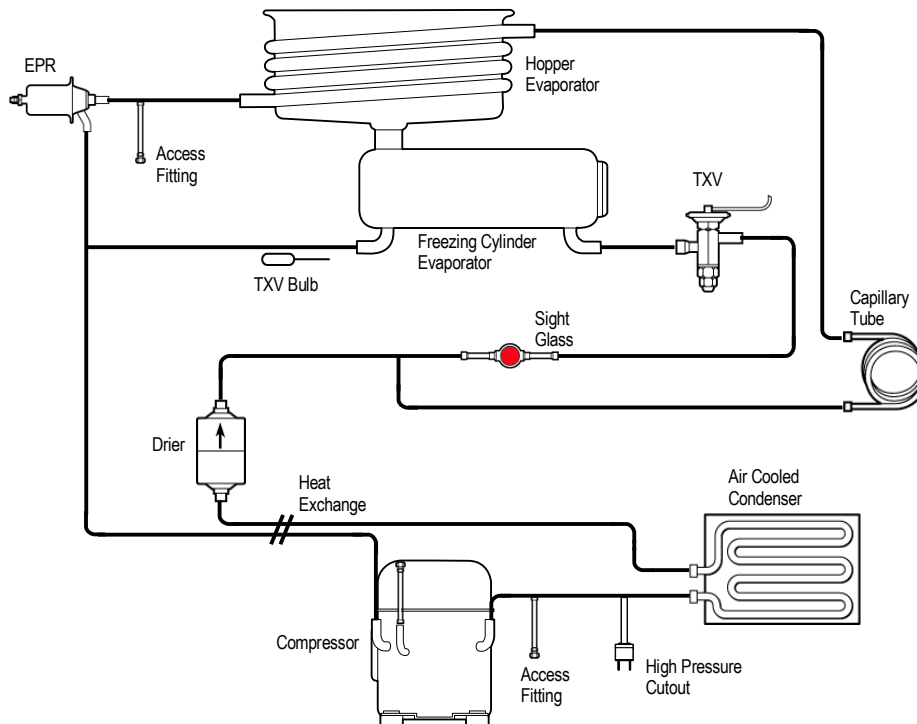

Figure 5-1 E112 Refrigeration Diagram

- A. Disconnect the machine from electrical supply before removing any panels for servicing.
- B. Remove the right side panel.
- C. If evacuating the system, connect a vacuum gauge to the Schrader valve next to the evaporator.
- D. Connect the recovery or evacuation unit to the suction and discharge service valves of the compressor.
- E. Perform the recovery or evacuation:
 - For recovery
 - Operate the recovery unit per manufacturer's instructions.
 - For evacuation
 - Evacuate the system until the gauge reads 300 microns of mercury (300 μ Hg). Turn off evacuation unit and wait 5 minutes.
 - If the gauge stays below 500 μ Hg, the system is properly evacuated.
 - If the gauge slowly rises to 1500-2000 μ Hg, there is still moisture in the system and further evacuation is required.
 - If the gauge rises to atmosphere, the system has a leak which must be resolved before continuing.
- F. Remove evacuation or recovery unit and gauge.

- B. If the system has been opened or if there was a leak, refer to Section 5.2 - Refrigerant Recovery and Evacuation to evacuate the system prior to charging.
- C. Refer to machine's information plate for total charge requirements.

NOTE

The refrigeration systems of the E112 and F112 are critically charged. Be sure to charge the system to the weight listed on the machine's information plate.

- D. For liquid refrigerant charging, connect refrigerant cylinder to the discharge Schrader valve of the compressor.
- E. Add the proper amount of refrigerant according to the machine's information plate.

5.4 COMPRESSOR

The E112 and F112 have hermetic reciprocating compressors (Refer to Figures 5-2 and 5-3).

5.3 REFRIGERANT CHARGING

Refer to the following procedures to properly charge the refrigeration system. Stoelting recommends liquid refrigerant charging.

NOTE

For qualified service personnel only. Anybody working with refrigerants must be certified as a Technician TYPE I as required by 40 CFR 82 Subpart F and hold all State and/or local refrigerant handling certifications. In addition, all handling, storage, and disposal of refrigerants must be in accordance with Environmental Protection Agency (EPA) guidelines and standards and all State and local guidelines and standards.

- A. Ensure the electrical supply has been removed before continuing.



Figure 5-2 E112 Compressor

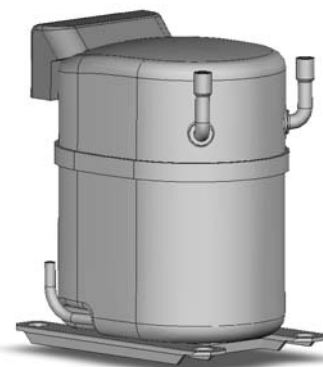

Figure 5-3 F112 Compressor



WARNING

Hazardous voltage

The CLEAN-OFF-ON switch must be placed in the OFF position when disassembling for servicing. The machine must be disconnected from electrical supply before removing any access panel. Failure to disconnect power before servicing could result in death or serious injury.

A. WINDING TEST

To test the compressor motor windings for possible problems, perform the following steps:

- A. Disconnect the machine from electrical supply before removing any panels for servicing.
- B. Remove the right side panel.
- C. Remove the protective cover from the compressor terminals. Disconnect the three terminals; C (common), R (run), and S (start).
- D. Connect an ohmmeter to the C and R terminals on the compressor. Resistance through the run winding should be as follows:
E112 - $0.6\Omega \pm 10\%$
F112 - $1.41\Omega \pm 10\%$
- E. Connect an ohmmeter to the C and S terminals on the compressor. Resistance through the start winding should be as follows:
E112 - $4.03\Omega \pm 10\%$
F112 - $2.65\Omega \pm 10\%$
- F. To check if windings are shorted to ground, connect one ohmmeter lead to a bare metal part on the compressor (such as any copper line leading to or from the compressor) and check terminals C, R, and S.

NOTE

The compressor is equipped with an internal overload protector. If the compressor is warm and ohmmeter readings indicate an open winding, allow up to one hour for overload to reset.

B. COMPRESSOR REMOVAL

E112 COMPRESSOR REMOVAL

- A. Disconnect the machine from electrical supply before removing any panels for servicing.
- B. Remove the protective cover from the compressor terminals and disconnect the wires.
- C. Recover refrigerant charge per the instructions in Section 5.2.
- D. Leave a port open to prevent pressure buildup during compressor removal.
- E. Remove six inches of insulating tubing on the suction line going to the compressor and unsweat the suction and discharge line from the compressor.
- F. Remove the four nuts and washers from the base of the compressor.
- G. Remove the compressor through the side of the machine.

- H. Remove the four rubber compressor mounts from the compressor.
- I. Plug all open ports of the old compressor.

NOTE

A compressor returned to Stoelting with any open ports will void the warranty. ALWAYS plug ports on a compressor that has been removed.

F112 COMPRESSOR REMOVAL

- A. Disconnect the machine from electrical supply before removing any panels for servicing.
- B. Remove the protective cover from the compressor terminals and disconnect the wires.
- C. Recover refrigerant charge per the instructions in Section 5.2.
- D. Leave a port open to prevent pressure buildup during compressor removal.
- E. Remove the insulation around the tubing on the suction line going to the compressor and unsweat the suction line from the compressor. (Fig. 5-4)
- F. Apply a heat sink (wet cloth) to the high pressure cutout and unsweat the tubing at the tee.
- G. Remove the four nuts and washers from the base of the compressor.
- H. Remove the compressor through the right side of the machine by tilting the compressor base outward.
- I. Remove the four rubber compressor mounts from the compressor.
- J. Apply a heat sink to the high pressure cutout and unsweat the discharge line from the compressor.
- K. Unsweat the suction line access fitting from the compressor.
- I. Plug all open ports of the old compressor.

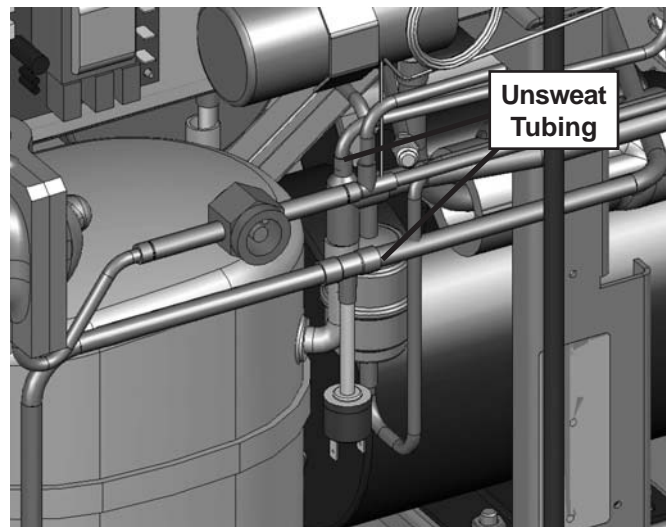

Figure 5-4 Compressor Removal - F112

NOTE

A compressor returned to Stoelting with any open ports will void the warranty. ALWAYS plug ports on a compressor that has been removed.

C. COMPRESSOR INSTALLATION

E112 COMPRESSOR INSTALLATION

- A. Make sure the machine is disconnected from the electrical supply before servicing.
- B. Install the four rubber mounts on the compressor.
- C. Install the compressor into the machine, fitting the base over the four bolt holes.
- D. Install the four washers and nuts onto the bolts and tighten securely.
- E. Remove all tubing plugs from the replacement compressor.

NOTE

The compressor plugs protect the compressor from moisture in the air. Do not remove the plugs until you are ready to install. The compressor must not be opened to the atmosphere for more than 10 minutes.

- F. Leave a port open to prevent pressure buildup. Braze the suction and discharge line to the compressor.
- G. Connect the wires to the compressor terminals.
- H. Replace the drier per the instructions in Section 5.8.
- I. Evacuate the system per the instructions in Section 5.2
- J. Recharge the system per the instructions in Section 5.3.
- K. Replace the insulating tubing on the suction line.

F112 COMPRESSOR INSTALLATION

- A. Make sure the machine is disconnected from the electrical supply before servicing.
- B. Remove all tubing plugs from the replacement compressor.

NOTE

The compressor plugs protect the compressor from moisture in the air. Do not remove the plugs until you are ready to install. The compressor must not be opened to the atmosphere for more than 10 minutes.

- C. Apply a heat sink (wet cloth) to the high pressure cutout and braze the tubing to the compressor.
- D. With the port open, braze the access fitting to the compressor.
- E. Install the four rubber mounts on the compressor.
- F. Install the compressor into the machine, fitting the base over the four bolt holes.

- G. Install the four washers and nuts onto the bolts and tighten securely.
- H. Leave a port open to prevent pressure buildup. Braze the suction line to the compressor.
- I. Apply a heat sink (wet cloth) to the high pressure cutout and braze the tee to the refrigeration line.
- J. Connect the wires to the compressor terminals.
- K. Replace the drier per the instructions in Section 5.8.
- L. Evacuate the system per the instructions in Section 5.2
- M. Recharge the system per the instructions in Section 5.3.
- N. Replace the insulating tubing on the suction line.

5.5 CONDENSER

The E112 has an air-cooled condenser. The F112 has either an air-cooled or water-cooled condenser. The capacity of the machine is directly related to keeping the condenser clean and free of debris, regardless of cooling type.

The air-cooled condenser is a copper tube and aluminum fin type. The E112 must have a minimum of 3" of clearance on the sides and the F112 must have a minimum of 6" of clearance on the sides. The underside must be kept clear for proper air flow.

The water-cooled condenser on an F112 is a tube and shell type. This condenser requires cool, clean water to function properly. Inlet and discharge lines must be 3/8" ID minimum.

CONDENSER TESTING

The condenser can be checked for leaks using the bubble test or using a leak detector.

5.6 VALVES

A. THERMOSTATIC EXPANSION VALVE (TXV)

The Thermostatic Expansion Valve (TXV) is used to meter the refrigerant to the evaporator. It does so by maintaining a low, constant superheat in the evaporator. The self-regulating TXV is preset by the manufacturer and adjustment is not recommended. (Fig. 5-5)

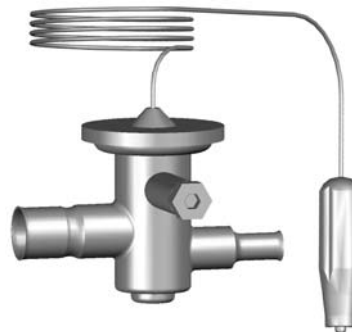

Figure 5-5 TXV

TXV TESTING & ADJUSTMENT

NOTE

The TXV bulb has an indent which must be positioned against the tubing. Good contact between the bulb and the suction line is necessary for proper operation of the valve. The bulb must also be well insulated.

- A. Connect a gauge to the Schrader valve on the suction line.
- B. Connect a thermocouple to the suction line next to the evaporator. Make sure the thermocouple is making direct contact with the suction line and insulate the the thermocouple to obtain a correct reading.
- C. Immediately before the refrigeration cycle ends, the superheat should be 7-10°F. This temperature is based on a full load in the freezing cylinder and an ambient temperature of 70°F. The gauge should read the following:
E112: 20-22 psig
F112: 30-32 psig
- D. If the readings are higher than expected, check to see if there is an overcharge of refrigerant. Also make sure the TXV bulb is making good contact with the suction line and it is well insulated.
- E. If the readings are lower than expected, check to see if there is a low refrigerant charge or if there is a restriction in the system.

NOTE

The TXV is the LAST component to adjust in the refrigeration system.

- F. The TXV can be adjusted after the steps above are completed. When adjusting, do not turn the valve over 1/4 turn (90°). Turn the valve stem clockwise to increase the superheat or counterclockwise to decrease the superheat.

TXV REMOVAL

- A. Remove the side panel.
- B. Remove bulb from suction line exiting from the evaporator.
- C. Recover refrigerant charge per instructions in Section 5.2.
- D. Leave a port open to prevent pressure buildup during TXV removal.
- E. Remove any insulation from the TXV and immediate surrounding lines.
- F. Apply a heat sink (wet cloth) to the valve dome.
- G. Unsweat the TXV and remove.

TXV REPLACEMENT

To replace the TXV, perform the following procedures:

- A. Position the TXV with a heat sink into the system.
- B. With an open port, braze the TXV into the system using appropriate brazing material.
- C. Remove the heat sink from the TXV.
- D. Install bulb on suction line exiting the evaporator using existing clamp. The bulb has an indent which must be placed against the tubing.

NOTE

The TXV bulb should ALWAYS be mounted on the horizontal line, with the capillary end facing the flow of refrigerant. Good contact between the bulb and the suction line is necessary for proper operation of the valve. The bulb must also be well insulated.

- E. Tighten clamp to 20 in/lb using a torque wrench.
- F. Replace insulation to the TXV and surrounding lines.
- G. Replace the drier per the instructions in Section 5.9.
- H. Evacuate the system per the instructions in Section 5.2.
- I. Recharge the system per the instructions in Section 5.3.

B. HIGH PRESSURE CUTOUT

The high pressure cutout stops the compressor if the discharge pressure reaches 445 psig (Refer to Figure 5-6).



Figure 5-6 High Pressure Cutout

HIGH PRESSURE CUTOUT TEST

- A. Connect a gauge to the Schrader valve on the discharge line.

- B. Disconnect cooling:
Air-Cooled - Disconnect evaporator fan
Water-Cooled - Shut off water supply
- C. High pressure cutout should trip when pressure reaches 445 psig \pm 9.

HIGH PRESSURE CUTOUT REMOVAL

- A. Remove the right side panel.
- B. Disconnect terminals from high pressure cutout.
- C. Recover refrigerant charge per instructions in Section 5.2.
- D. Leave a port open to prevent pressure buildup during removal.
- E. Apply a heat sink (wet cloth) to the cutout.
- F. Unsweat cutout from discharge line.

HIGH PRESSURE CUTOUT REPLACEMENT

- A. Apply a heat sink (wet cloth) to the new cutout.
- B. With an open port, braze the cutout to the discharge line.
- C. Replace the drier per the instructions in Section 5.9.
- D. Evacuate the system per the instructions in Section 5.2.
- E. Recharge the system per the instructions in Section 5.3.
- F. Connect the high pressure cutout.

C. EVAPORATOR PRESSURE REGULATOR (EPR)

There is one EPR in the refrigeration system (Refer to Figure 5-7). It is located on the suction line of the hopper evaporator and regulates refrigerant pressure.

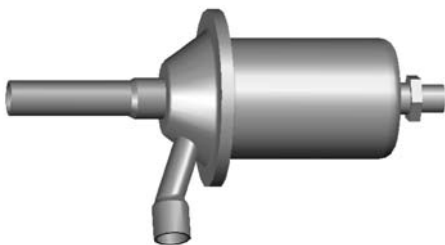

Figure 5-7 EPR Valve

EPR TEST AND ADJUSTMENT

- A. Place the CLEAN/OFF/ON switch in the OFF position.
- B. Connect a gauge to the Schrader valve on the suction line.
- C. Place the CLEAN/OFF/ON switch to the ON position.
- D. If the gauge does not read 60 psig \pm 2 then adjustment is needed.

- E. Remove the plastic cap and loosen the locknut on the EPR. Using a small screwdriver, turn the adjustment screw counterclockwise 1/2 turn, then adjust as necessary. Turn the valve stem clockwise for less cooling or counterclockwise for more cooling.
- F. Allow the system to stabilize for 5 minutes to ensure pressure remains stable.

EPR REMOVAL

- A. Remove the side panel.
- B. Recover refrigerant charge per instructions in Section 5.2.
- C. Leave a port open to prevent pressure buildup during EPR removal.
- D. Unsweat the EPR and remove.

EPR REPLACEMENT

To replace the EPR, perform the following procedures:

- A. Apply a heat sink (wet cloth) to the EPR.
- B. With an open port, braze the EPR into the system using appropriate brazing material.
- C. Remove the heat sink from the hot gas bypass.
- D. Replace the filter drier. Refer to Section 5.8 for details.
- E. Evacuate and recharge system per instructions in Section 5.2.
- F. Adjust the suction pressure to 60 psig \pm 2.

D. WATER VALVE (WATER COOLED MODELS ONLY)

The water valve monitors refrigerant pressure and opens on an increase of pressure. The opening point pressure is the refrigerant pressure required to lift the valve disc off the valve seat. (Figure 5-7)

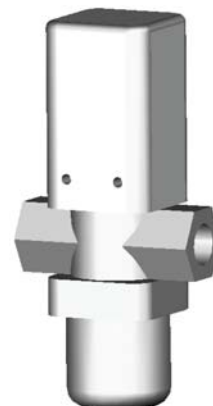

Figure 5-8 Water Valve

WATER VALVE ADJUSTMENT

- A. Remove the back panel.
- B. Connect a gauge to the compressor discharge Schrader valve.

- C. Take the temperature of the inlet water.
- D. Connect the machine to the electrical supply, start the refrigeration cycle, and read the pressure.
- D. Refer to the chart below for correct pressures and water outlet temperatures:

Inlet Water Temperature	Discharge Pressure	Outlet Water Temperature
60°F	225-235 psig	81° - 93°F
70°F	227-237 psig	83° - 95°F
80°F	229-239 psig	84° - 96°F
90°F	248-258 psig	90° - 102°F
100°F	282-292 psig	100° - 112°F
110°F	317-327 psig	109° - 121°F

Table 5-1 Water Cooled Pressure/Temperature Table

- E. If the water temperature is too low, the opening point pressure should be increased to slow the water flow. Turn the adjustment screw counterclockwise.
- F. If the water temperature is too high, the opening point pressure should be decreased to increase the flow of water. Turn the adjustment screw clockwise.

WATER VALVE REMOVAL

The water valve is connected to the refrigeration system by capillary tube brazed to the discharge line.

- A. Turn off and disconnect the water supply. Blow out the water lines with compressed air or CO₂.
- B. Recover refrigerant charge per instructions in Section 5.2.
- C. Unsweat the capillary tube from the discharge line.
- E. Remove the clamps from the water lines at the valve.
- F. Remove the two screws holding the water valve to the frame and remove the valve.

WATER VALVE REPLACEMENT

To replace the water valve, perform the following procedures:

- A. Position the water valve and attach to the frame using the two screws.
- B. Install the water lines onto the valve with hose clamps.
- C. Braze the capillary tube into the system using BCuP-3 or BCuP-5 brazing material.
- D. Connect the water supply line and turn on the water supply.



Figure 5-9 Capillary Tube

- E. Check for leaks in the water lines. If there are no leaks, turn off the water supply.
- F. Replace the filter drier. Refer to Section 5.8 for details.
- G. Evacuate and recharge system per instructions in Section 5.2.
- H. Turn on the water and check for leaks in the water lines with the refrigeration system running.
- I. Adjust the valve as necessary.

5.7 CAPILLARY TUBE

The capillary tube meters refrigerant flow in the hopper evaporator (Refer to Figure 5-9). The amount of flow is dependent on the length and ID of the capillary tube as well as the refrigerant charge.

CAPILLARY TUBE REMOVAL

- A. Recover refrigerant charge per instructions in Section 5.2.
- B. Leave a port open to prevent pressure buildup during capillary tube removal.
- C. Remove foam insulation from the capillary tube at the evaporator inlet.
- C. Unsweat the capillary tube and remove.

CAPILLARY TUBE REPLACEMENT

- A. Position the capillary tube in place.
- B. Apply a heat sink (wet cloth) to the capillary tube and drier assembly.
- C. With an open port, braze the capillary tube into the system using appropriate brazing material.
- D. Replace foam insulation to the capillary tube at the evaporator inlet.
- E. Evacuate the system per instructions in Section 5.2.
- F. Recharge the system per instructions in Section 5.3.

FILTER DRIER REPLACEMENT

- A. Position the filter drier so the arrow is pointing towards the evaporators (pointing away from the condenser).
- B. Apply a heat sink (wet cloth) to the filter drier.
- C. With an open port, braze the filter drier into the system using appropriate brazing material.
- D. Evacuate the system per instructions in Section 5.2.
- E. Recharge the system per instructions in Section 5.3.

5.8 FILTER DRIER

The filter drier must be replaced every time the refrigeration system is opened for service. A new filter drier improves operation of the entire refrigeration system by stopping the circulation of moisture and by removing harmful contaminants (Refer to Figure 5-10).

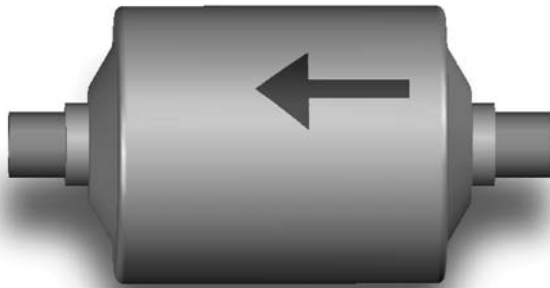

Figure 5-10 Filter Drier

FILTER DRIER REMOVAL

- A. Recover refrigerant charge per instructions in Section 5.2.
- B. Cut the refrigeration line as close to the filter drier as possible and remove drier.
- C. Cap the ends of the drier using the plugs from the new drier.

NOTE

The drier must be capped to prevent moisture from the environment

SECTION 6 ELECTRICAL AND MECHANICAL CONTROL SYSTEMS

NOTE

The wiring diagrams are located in Section 8.

6.1 CONTROL BOARD

The control board uses a microprocessor to control all timing and mode operations. It processes information from the motor and spigot and sends signals to the compressor and motor.

NOTE

The control board is designed for use at 115VAC or 208-230VAC. A connector and resistor determine the voltage setting of the control board. Refer to Figure 6-1 for the location of the connector and resistor.

CONTROL BOARD TEST

The following test will show if the control board has proper voltage.

1. Open the right side panel.
2. When the CLEAN-OFF-ON switch is in the ON position, read voltage on the control board across the L1 terminal and one of the neutral terminals (P2, P3, P4 or P5). Voltage should be near line voltage (115VAC on E112 and 220VAC on F112).

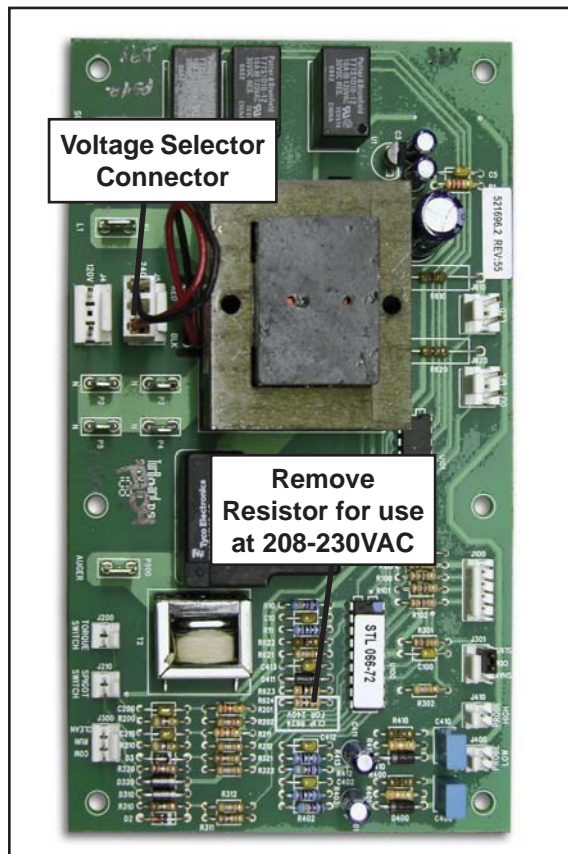

Figure 6-1 Control Board



WARNING

Service to the machine must be completed by a qualified electrician/refrigeration specialist.

Any tests or work done on the machine must be done by a qualified technician. Service to the machine done by an unqualified person, could result in serious personal injury.

6.2 CONTACTOR

The compressor contactor is mounted behind the right panel. The control board sends electronic signals to trigger the contactor and start the compressor.

A. CONTACTOR TESTS

The following test will show if the control board is sending a voltage signal to the contactor.

1. Open the right side panel.
2. When the CLEAN-OFF-ON switch is in the ON position, read voltage on the control board across the L1 terminal and one of the neutral terminals (P2, P3, P4 or P5). Voltage should be near line voltage (115VAC on E112 and 220VAC on F112).
3. Read voltage on the control board across the L1 terminal and the COMPRESSOR CONTACTOR terminal during a freezing cycle. Voltage should be 0V.

The following test will show if a contactor is receiving a voltage signal from the control board.

1. Open the right side panel.
2. Read voltage across the coils of the contactor during a freezing cycle. Voltage should be near line voltage (115VAC on E112 and 220VAC on F112). If there is no voltage reading, refer to Section 7 Troubleshooting.

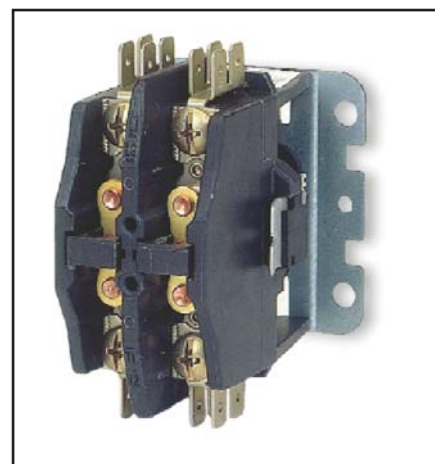

Figure 6-2 Contactor

6.3 DRIVE MOTOR

The drive motor is used to rotate the auger assembly. An internal, normally closed, centrifugal switch starts the drive motor. The motors have an internal thermal overload.

A. DRIVE MOTOR VOLTAGE TEST

The following test will show if the relay on the control board is working properly and sending a voltage signal to the drive motor.

1. Open the right side panel.
2. When the CLEAN-OFF-ON switch is in the ON position, read voltage on the control board across the L1 terminal and one of the neutral terminals (P2, P3, P4 or P5). Voltage should be near line voltage (115VAC on E112 and 220VAC on F112).
3. Read voltage across the L1 terminal and the AUGER terminal. Voltage should be 0V.

B. DRIVE MOTOR REPLACEMENT

E112 MOTOR REMOVAL

1. Disconnect machine from electrical supply before removing any panels for servicing.
2. Remove the back panel and the right side panel.
3. Remove the ground wire from the machine frame.
4. Loosen the motor cradle clamps at the front and back of the motor.
5. Rotate the motor so that the electrical cover plate can be removed. Remove the cover plate from the back of the motor.
6. Identify (mark) wires and remove them from the motor.
7. Remove the belt tension adjustment nut and remove the belt.
8. Remove the two bolts from the bushing clamp at the rear of the machine and pull the motor out through the back of the machine.
9. Remove the bolts that connect the motor to the mounting plate.

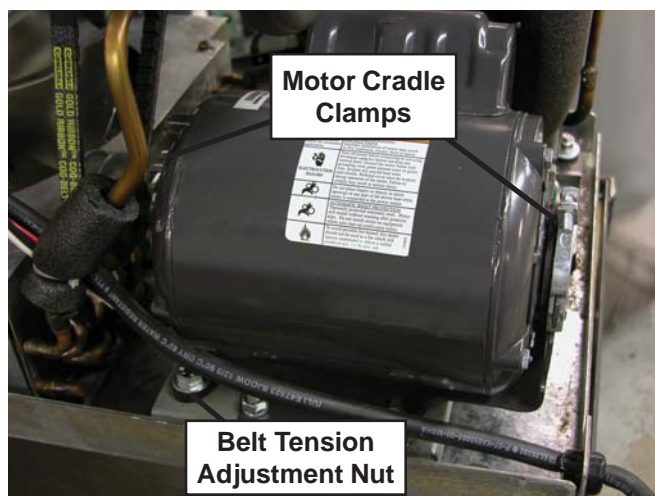

Figure 6-3 E112 Drive Motor

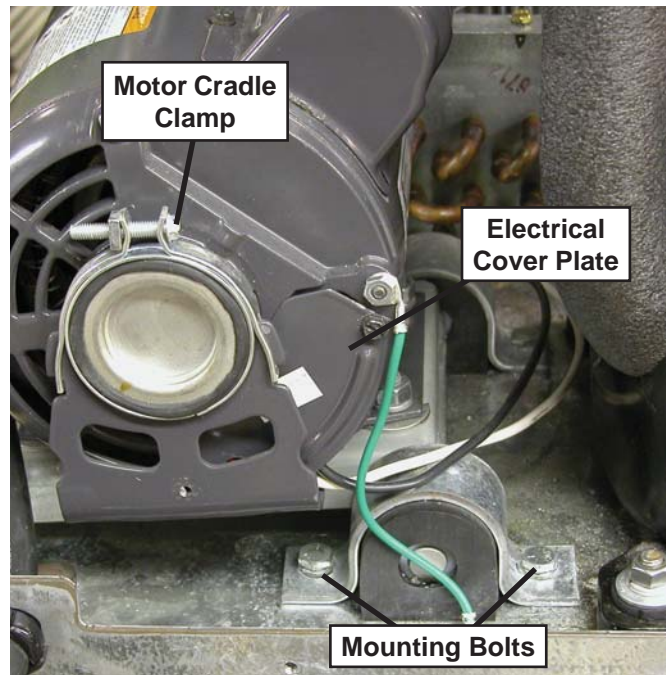

Figure 6-4 E112 Drive Motor

10. Loosen the two allen head screws from the pulley.
11. Remove the pulley and key from the motor shaft.

E112 MOTOR INSTALLATION

1. Place the drive motor on the mounting plate and install the four mounting bolts.
2. Place the pulley and key on the motor shaft.

NOTE

Do not tighten the pulley screws until after the belt tension has been properly adjusted.

3. Install the motor and mounting plate in the machine to the bushing clamp using the mounting bolts.
4. Install the belt and the tension bolt. Tighten the tension bolt.
5. Use a Burroughs Belt Tension Gauge to set the tension for the drive belt. Set the E112 belt tension to 5-15 lbs.
6. Using a straightedge, align the drive motor pulley with the gearbox pulley. Tighten the two allen head screws on the drive motor pulley.
7. Loosen the motor cradle clamps at the front and back of the motor.
8. Rotate the motor so that the electrical cover plate can be removed. Remove the cover plate from the back of the motor.
9. Install wiring according to the wiring diagram. Install the electrical cover plate.
10. Tighten the motor cradle clamps.
11. Install back and side panels.

F112 MOTOR REMOVAL

1. Disconnect machine from electrical supply before removing any panels for servicing.
2. Remove the back panel and the right side panel.
3. Remove the electrical cover plate from the back of the motor.
4. Identify (mark) wires and remove them from the motor.
5. Loosen the belt tension adjustment nut and remove the belt.
6. Remove the motor mounting bolts.
7. Remove the motor through the back of the machine.
8. Loosen the two allen head screws from the pulley.
9. Remove the pulley and key from the motor shaft.

F112 MOTOR INSTALLATION

1. Place the pulley and key on the motor shaft.

NOTE

Do not tighten the pulley screws until after the belt tension has been properly adjusted.

2. Place the drive motor in position and install the four mounting bolts.
3. Install the belt and tighten the tension bolt.
4. Use a Burroughs Belt Tension Gauge to set the tension for the drive belt. Set the F112 belt tension to 20-30 lbs.
5. Using a straightedge, align the drive motor pulley with the gearbox pulley. Tighten the two allen head screws.
6. Install wiring according to wiring diagram. Install electrical cover plate.
7. Install back and side panels.

6.4 CAPACITORS

The compressor start and run capacitors are mounted behind the right side panel. The capacitors for the drive motor are mounted directly onto the motor body. The E112 has one drive motor capacitor. The F112 has two drive motor capacitors: a run capacitor and a start capacitor.

A. CAPACITOR TEST

1. Place the CLEAN-OFF-ON switch in the OFF position.
2. Remove a lead from one of the capacitor terminals.
3. Using insulated pliers, discharge the capacitor with a 20K Ω 5W resistor across the terminals.

NOTE

Discharge the capacitor even if there is a bleeder resistor across the terminals. There may be an open in the bleeder resistor preventing it from working properly.

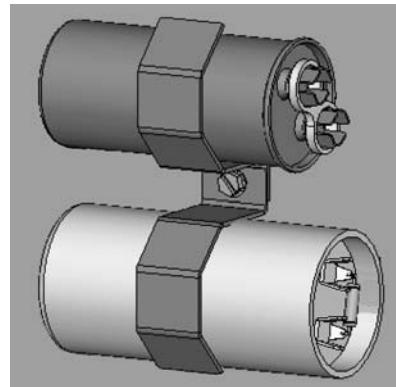

Figure 6-5 Compressor Capacitors

4. Disconnect the bleeder resistor from the circuit.
5. Measure capacitance across the terminals. The results should be as follows:

E112	Part	Rating	
		MFD	VAC
Drive Motor	230440	378-454 MFD	110 VAC
Compressor Start	231058	145-174 MFD	250 VAC
Compressor Run	230648	25 MFD	440 VAC

F112	Part	Rating	
		MFD	VAC
Drive Motor Start	231095	500 MFD	125 VAC
Drive Motor Run	231078	50 MFD	370 VAC
Compressor Start	230632	72-86 MFD	330 VAC
Compressor Run	231084	30 MFD	370 VAC

6. Check the resistance across the capacitor terminals. The reading should be close to 0 and will rise slowly (as the meter charges the capacitor).
6. If the resistance stops increasing, there may be an internal short in the capacitor.
7. Discharge the capacitor if the test needs to be repeated.

B. CAPACITOR REPLACEMENT

1. Place the CLEAN-OFF-ON switch in the OFF position.
2. Remove leads from the capacitor terminals.
3. Using insulated pliers, discharge the capacitor with a 20K Ω 5W resistor across the terminals.

NOTE

Discharge the capacitor even if there is a bleeder resistor across the terminals. There may be an open in the bleeder resistor preventing it from working properly

4. Pull the capacitor out of its holder and replace.
5. Connect the leads to the terminals.

6.5 GEARBOX

A. GEARBOX INSPECTION

Inspect the gearbox and listen for unusual noise. A grinding sound generally indicates a bad gear.

B. GEARBOX REMOVAL

1. Disconnect machine from electrical supply before removing any panels for servicing.
2. Remove the back panel and the side panel.
3. Remove protective shield from side of machine.
4. Remove the belts.
5. Remove the pulley by loosening the set screws.
6. Remove the three bolts holding the gearbox to the barrel.
4. Remove the two bolts holding the gearbox to the mounting bracket and remove the gear box through the rear of the machine.

C. GEARBOX INSTALLATION

1. Place the gear box in position from the rear of the machine. Fasten the three bolts through the gear box to the rear of the barrel.
2. Fasten the gearbox to the mounting bracket using the two bolts.
3. Mount the pulley on the gear box shaft and align with the motor pulley, then tighten the allen head screws.
4. Install the belt.
5. Press firmly on the belt.
6. When the tension is properly adjusted, the belt will depress the approximate width of the belt with the pressure of a finger.
7. If an adjustment is necessary, loosen the four motor plate retaining nuts, adjust belt tension then retighten the four nuts.

6.6 CONDENSER FAN MOTOR (AIR-COOLED ONLY)

A. FAN MOTOR REPLACEMENT

1. Disconnect machine from electrical supply before removing any panels for servicing.
2. Remove the panels and the header panel as noted below.
E112: Remove both side panels
F112: Remove the left side panel and rear panel
3. Trace and disconnect the wires on the T1 and T2 terminals on the compressor contactor. The F112 has a black and white wire connected to the contactor. The E112 has two black wires.
4. Remove the four screws on the fan motor bracket and remove the bracket. Be careful to not damage the fins on the condenser when removing the fan.

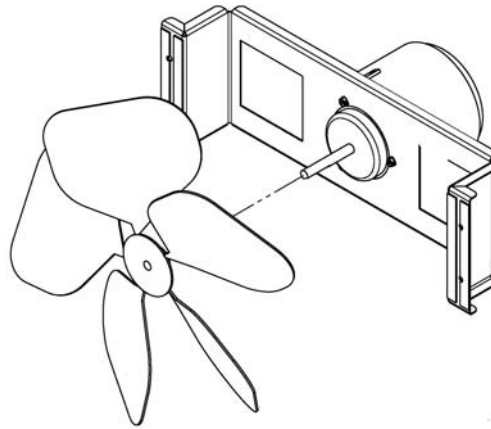

Figure 6.6 Fan Motor Replacement

5. Loosen set screw on fan blade.
6. Remove the three bolts from the fan motor mounting plate and remove the motor.

B. FAN MOTOR INSTALLATION

5. Route the wires to the compressor contactor.
6. Connect the wires to the contactor as follows:
F112: Connect black wire to the T1 terminal. Connect white wire to the T2 terminal.
E112: Connect a black wire to the T1 terminal and connect the other black wire to the T2 terminal. It does not matter which wire is connected to which terminal.
3. For F112 only: Ensure the purple wire is terminated, and the ensure red wire is terminated with blue wire.
1. Attach motor to the mounting plate with the three bolts.
2. Place fan blade on motor shaft. Make sure the motor shaft does not extend past the hub of the fan blade.
7. Install the fan motor bracket to the condenser.
8. Position the fan on the motor shaft so that the blades are 3/8" from the fins on the condenser. Tighten the set screw.

6.7 SWITCHES

A. SPIGOT SWITCH

The spigot switch is a normally closed, held open switch. When a spigot is pulled, the spigot switch sends a signal to the control board to start the drive motor.

SPIGOT SWITCH TESTING - ELECTRICAL

1. Disconnect the switch from the circuit by unplugging the connector.

2. Check resistance readings across the common (COM) and normally closed (NC) terminals. When the spigot is closed (not dispensing), the resistance should show an open. When the spigot is opened (during dispensing), the switch will close and the resistance should be 0 ohms.

SPIGOT SWITCH REPLACEMENT

1. Remove the header panel.
2. Disconnect the connector from the switch and remove the switch.
3. Install the replacement switch onto the spigot assembly.
4. Attach the connector to the spigot switch.
5. Replace the header panel and secure with the two Phillips head screws.

B. TORQUE SWITCH

The torque switch is a normally open switch. During the freezing cycle, the product in the freezing cylinder increases consistency. As product consistency increases, the stator bar rotates and moves the torque rod. When the torque rod activates the torque switch, the product in the freezing cylinder is at consistency.

TORQUE SWITCH TEST

1. Disconnect the switch from the circuit by unplugging the connector.
2. Check resistance readings across the common (COM) and normally open (NO) terminals. When the switch is open, the resistance should show an open. When the switch is closed, the resistance should be 0 ohms.

TORQUE SWITCH REPLACEMENT

1. Remove the header panel.
2. Disconnect the connector from the switch and remove the switch.
3. Install the replacement switch onto the torque assembly.
4. Attach the connector to the torque switch.
5. Replace the header panel and secure with the two Phillips head screws.

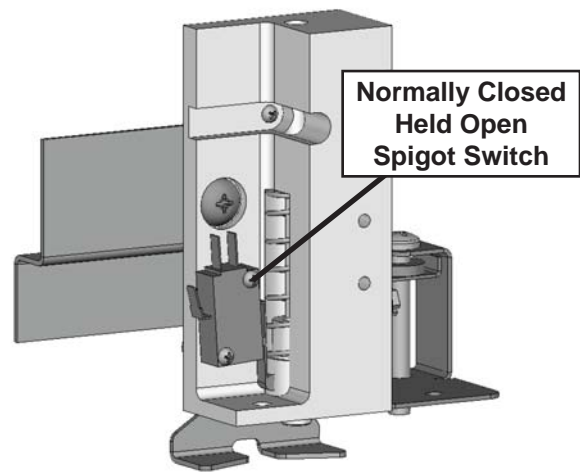

Figure 6-7 Spigot Switch

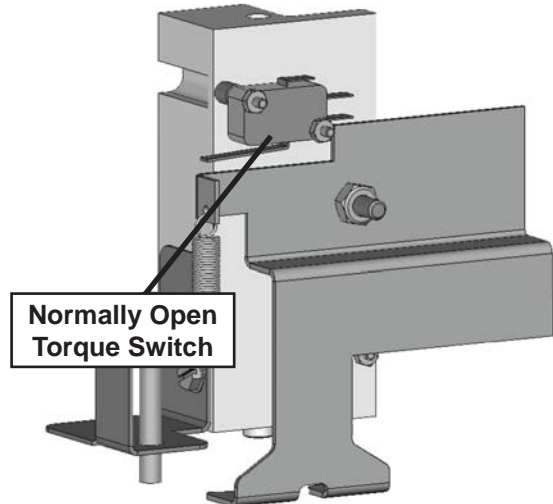

Figure 6-8 Torque Switch

SECTION 7 TROUBLESHOOTING

7.1 LIGHT INDICATORS

The machine has two lights that will alert the user if a problem occurs: an ADD MIX light and a Diagnostic Light.

The ADD MIX light will flash to alert the operator to a low mix condition. It does so by monitoring the mix level in the hopper. When the ADD MIX light is flashing, refill hopper immediately.

The Diagnostic Light will flash if an error occurs. Refer to the chart below for details.

Indication	On	One Blink	Two Blinks	Three Blinks
Conditions	Defrost Mode	Torque is not met after 20 minutes (22 minutes for shake)	Drive current is not sensed	Machine left in clean mode for over 20 minutes
Self Correction	N/A	N/A	The machine attempts to sense drive current with a 3 second pre-stir. If current is sensed, the machine will return to normal operation. If current is not sensed, the machine will wait 7 minutes and try to sense current with another 3 second pre-stir. After the third attempt, the compressor will run on timers.	N/A
Operation	Every 7 minutes the auger will run for 90 seconds.	Timers or until torque switch remains closed for 3 seconds.	Timers	Off
Corrective Action	N/A	Check for product in the hopper, check if the condenser is dirty, check the refrigeration system.	Check that there is power going to the contactor, check for power leaving the contactor, check for power at the motor.	Turn CLEAN-OFF-ON switch to OFF (middle) position then turn the switch to ON.

7.2 TROUBLESHOOTING

PROBLEM	POSSIBLE CAUSE	REMEDY
Machine does not run.	<ol style="list-style-type: none"> 1 Power to machine is off. 2 Blown fuse or tripped circuit. 3 Freeze-up (auger will not turn). 4 Front door not in place. 	<ol style="list-style-type: none"> 1 Supply power to machine. 2 Replace or reset. 3 Turn Clean/Off/On switch Off for 15 minutes, then restart. 4 Assemble front door in place.
Machine will not shut off before 22 minute Compressor Time Out Mode.	<ol style="list-style-type: none"> 1 Drive belt failure. 2 Consistency temperature setting is too firm. 3 Refrigeration problem. 	<ol style="list-style-type: none"> 1 Replace drive belt. 2 Turn Consistency Adjustment knob counter-clockwise. 3 Check system.
Product is too firm.	<ol style="list-style-type: none"> 1 Consistency temperature setting is too firm. 	<ol style="list-style-type: none"> 1 Turn Consistency Adjustment knob counter-clockwise.

7.2 TROUBLESHOOTING - CONTINUED

PROBLEM	POSSIBLE CAUSE	REMEDY
Product is too thin.	<ol style="list-style-type: none"> 1 No vent space for free flow of cooling air. 2 Condenser is dirty. 3 Consistency setting too soft. 4 Auger is assembled incorrectly. 5 Auto Fill Pump not operating. 6 Refrigeration problem. 	<ol style="list-style-type: none"> 1 A minimum of 6" of air space on both sides (the E112 requires 3"). (See Section 2) 2 Clean. (See Section 3) 3 Turn Consistency Adjustment knob clockwise. 4 Remove mix, clean, reassemble, sanitize and freeze down. 5 See Auto Fill Troubleshooting section. 6 Check system.
Product does not dispense.	<ol style="list-style-type: none"> 1 No mix in hopper. 2 Drive motor overload tripped. 3 Drive belt failure. 4 Freeze-up (Auger will not turn). 	<ol style="list-style-type: none"> 1 See Auto Fill Troubleshooting section. 2 Wait for automatic reset. 3 Replace drive belt. 4 Turn Clean/Off/On switch Off for 15 minutes, then restart.
Drive belt slipping or squealing.	<ol style="list-style-type: none"> 1 Worn drive belt. 2 Freeze-up (Auger will not turn). 3 Not tensioned properly. 	<ol style="list-style-type: none"> 1 Replace drive belt. 2 Turn Clean/Off/On switch Off for 15 minutes, then restart. 3 Adjust belt tension
Low overrun	<ol style="list-style-type: none"> 1 Auger is assembled incorrectly. 2 Mix inlet regulator missing. 3 Mix inlet regulator o-ring missing. 4 Mix inlet regulator air tube blocked. 5 Product breakdown. 	<ol style="list-style-type: none"> 1 Remove mix, clean, sanitize, and freeze down with fresh mix. 2 Replace mix inlet regulator. 3 Replace mix inlet regulator o-ring. 4 Clean with sanitized brush. 5 Fill machine with fresh product.
Rear auger seal leaks.	<ol style="list-style-type: none"> 1 Outside surface of rear auger seal is lubricated. 2 Rear seal missing or damaged. 3 Seal o-ring missing, damaged or installed incorrectly. 4 Worn or scratched auger shaft. 	<ol style="list-style-type: none"> 1 Clean lubricant from outside of rear seal, lubricate inside of seal and reinstall. 2 Check or replace. 3 Check. or replace. 4 Replace auger shaft.
Front door leaks.	<ol style="list-style-type: none"> 1 Front door knobs are loose. 2 Spigot parts are not lubricated. 3 Chipped or worn spigot o-rings. 4 O-rings or spigot installed wrong. 5 Inner spigot hole in front door nicked or scratched. 	<ol style="list-style-type: none"> 1 Tighten knobs. 2 See Section 3. 3 Replace o-rings. 4 Remove spigot and check o-ring. 5 Replace front door.

SECTION 8 REPLACEMENT PARTS

8.1 DECALS, LUBRICATION, PANELS & LEGS

Part	Description	Quantity	
		E112	F112
208135	Brush - 4" X 8" X 16" (Barrel)	1	1
208380	Brush - 1/4" X 3" X 14"	1	1
208401	Brush - 1" X 3" X 10"	1	1
232091	Cap - Protective (Gray) - #490716 Leg		1
236049	Card - Cleaning Instruction	1	1
324105	Decal - Caution Electrical Shock	1	1
324106	Decal - Caution Electrical Wiring Materials	1	1
324107	Decal - Caution Hazardous Moving Parts	1	1
324141	Decal - Caution Rotating Blades	1	1
324208	Decal - Attention Refrigerant Leak Check	1	1
324393	Decal - Stoelting Swirl Logo	1	1
324509	Decal - Cleaning Instructions	1	1
324548	Decal - Adequate Ventilation 6"		1
324566	Decal - Wired According To	1	1
324584	Decal - Adequate Ventilation 3"	1	
324686	Decal - Danger Automatic Start	1	1
324804	Decal - Domed Stoelting Swirl (Header Panel)	1	1
324852	Decal - Clean Condenser Filter	1	
324864	Decal - A&W Logo	-	-
324865	Decal - Standby Light	1	1
396244	Gasket - Freezer Base		1
430165	Cord - Power	1	
430172	Cord - Power		1
490716	Leg		4
490749	Leg - Front	2	
490750	Leg - Rear (w/Suction Cup)	2	
508048	Lubricant - Spline (2 oz Squeeze Tube)	1	1
508135	Petrol Gel - 4 oz Tube	1	1
513613	Manual - Owner's	1	1
649105	Screw - Self-Tapping (E112 - Side Panels) (F112 - All Panels)	-	-
649114	Screw - Header Panel & Bottle Rack		-
1183955	O-Ring Kit	-	-
2183639	Panel - L.H. Side	1	
2183640	Panel - R.H. Side	1	
2183641	Panel - Rear (E112 - Ser. #0 - #22767)	1	
2183647	Panel - Front (E112 - Ser. #0 - #22767)	1	
2183704	Panel - Header		1
2183710	Panel - Bottom		1
2183782	Panel - Electrical Cover (E112 - Ser. #22768 Plus)	1	
2183783	Panel - Front (E112 - Ser. #22768 Plus)	1	
2183808	Panel - Rear (E112 - Ser. #22768 Plus)	1	
2187029	Panel - R.H. Side		1
2187030	Panel - L.H. Side		1
2187036	Panel - Front		1
2187197	Panel - Rear (Air-Cooled)		1
2187241	Panel - Rear (Water-Cooled)		1
2187550	Panel - Front (A & W Only)		-
7183341	Panel - Electrical Cover (E112 - Ser. #0 - #22767)	1	

8.2 AUGER SHAFT AND FACEPLATE PARTS

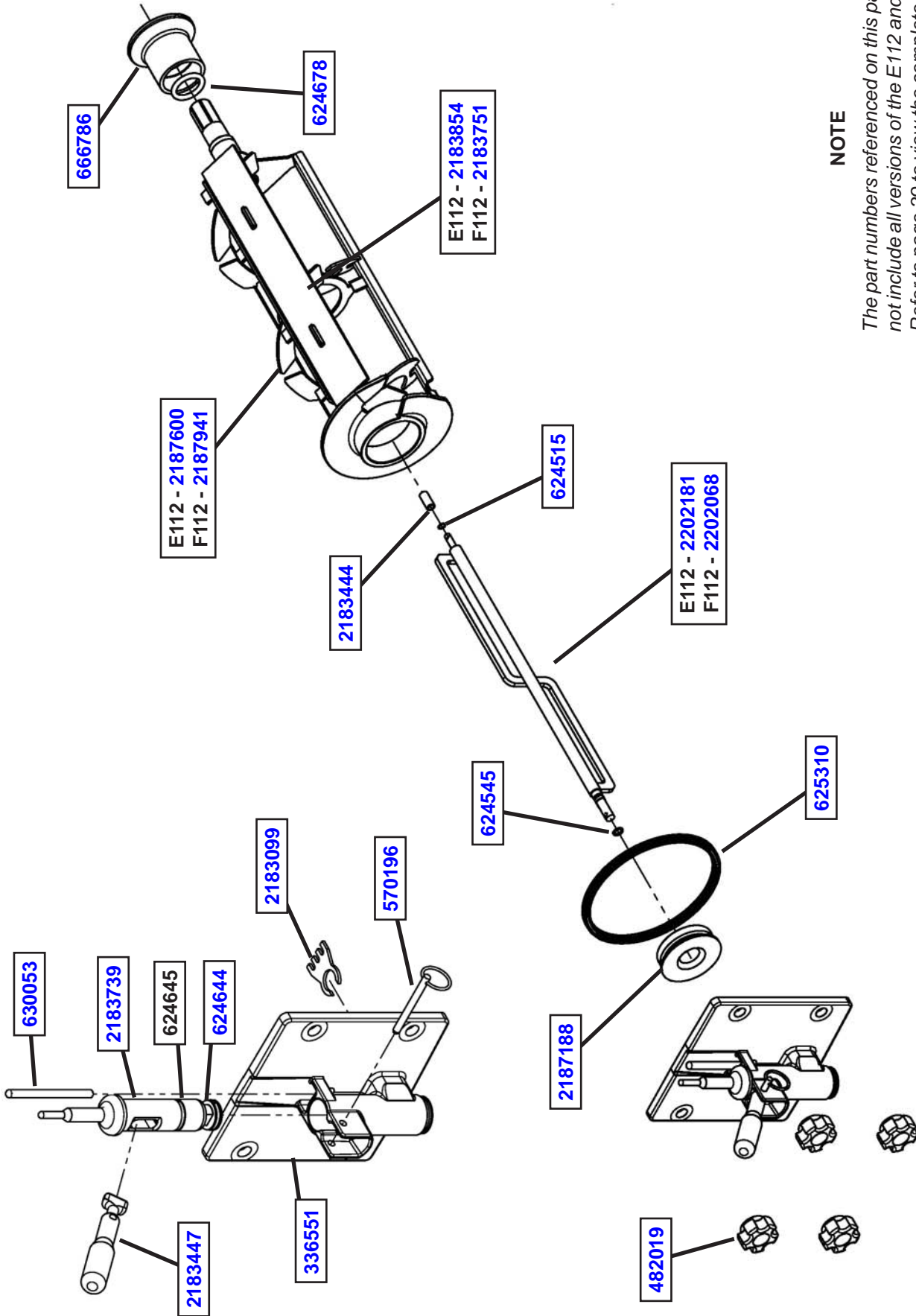

NOTE

The part numbers referenced on this page do not include all versions of the E112 and F112. Refer to page 39 to view the complete listing.

8.2 AUGER SHAFT AND FACEPLATE PARTS - CONTINUED

Part	Description	Quantity	
		E112	F112
162165	Blade - Scraper (E112 Ser. #22768 - #23376)	2	
336546	Door - Front (E112 - Ser. #0 - #23494)	1	
336551	Door - Front (E112 - Ser. #23495 Plus) (F112 - All)	1	1
482019	Knob - Front Door (Black)	4	4
570196	Pin - Cotterless Clevis (Front Door)	1	1
624515-5	O-Ring - Stator Bar Rear (5 Pack)	1	1
624545-5	O-Ring - Stator Bar Front (5 Pack)	1	1
624644-5	O-Ring - Spigot Body (Bottom) (5 Pack)	1	1
624645-5	O-Ring - Spigot Body (Top) (5 Pack)	1	1
624678-5	O-Ring - Rear Seal - Black (5 Pack)	1	1
625310	Quad-Ring - Front Door - Black	1	1
630053	Rod - Torque Actuator	1	1
666786	Seal - Rear Auger - Black	1	1
2183099	Breaker Bar - Spigot Body	1	1
2183100	Blade - Scraper (E112 - Ser. #0 - #22767)	2	
2183444	Bushing - Stator Support (Rear)	1	1
2183446	Spigot Body (E112 - Ser. #0 - #23197)	1	
2183447	Handle Only - Spigot	1	1
2183449	Bushing - Front Auger Support (F112 - Ser. #0 - #25280)	1	1
2183645	Rod Actuator - Spigot (E112 - Ser. #0 - #22767)	1	
2183739	Spigot Body (E112 - Ser. #23198 Plus) (F112 - All)	1	1
2183751	Blade - Scraper	1	1
2183854	Blade - Scraper (E112 - Ser. #23377 Plus)	1	
2187188	Bushing - Front Auger Support (E112 - All) (F112 - Ser. #25281 Plus)	1	1
2187225	Auger Shaft (F112 - Ser. #0 - #25280)	1	1
2187600	Auger Shaft	1	
2187941	Auger Shaft	1	1
2202068	Stator Bar	1	1
2202181	Stator Bar	1	

8.3 HOPPER PARTS

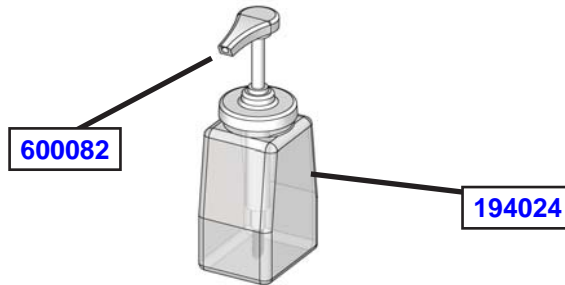
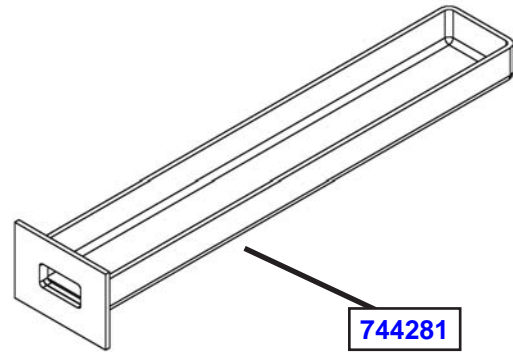
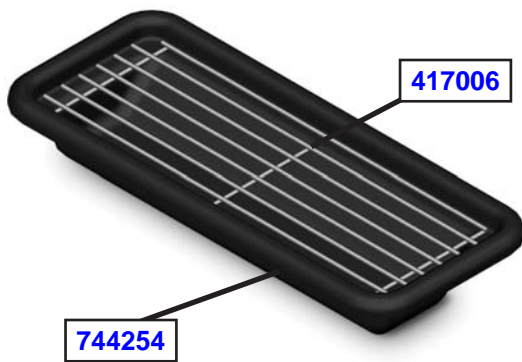
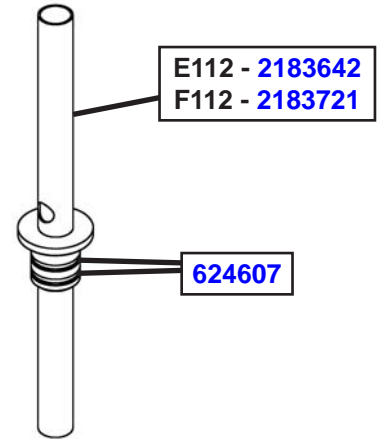
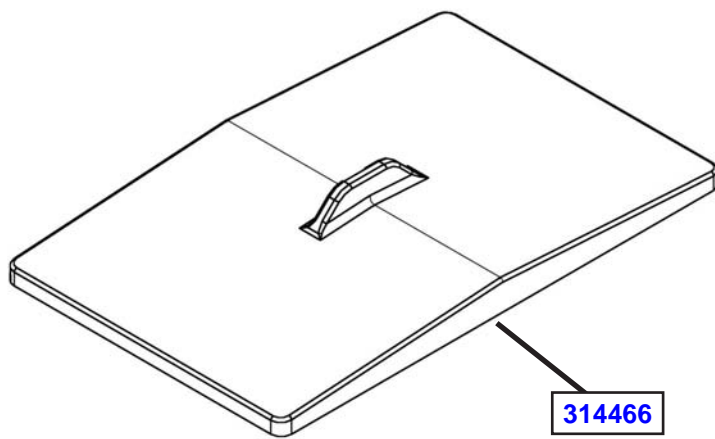

Part	Description	Quantity	
		E112	F112
194024	Bottle - Flavor (Plastic)	-	-
314466	Cover - Hopper (E112 - Non LJS) (F112 - Non Auto Fill)	1	1
417006	Grid - Drip Tray (Metal)	1	1
600082	Pump - Flavor (Plastic Bottle)	-	-
624607-5	O-Ring - Mix Inlet (5 Pack)	2	2
744254	Tray - Drip (E112 - Ser. #24587 Plus) (F112 - All)	1	1
744273	Tray - Drip (E112 - Ser. #0 - #24586)	1	-
744281	Tray - Drain (Front)	1	1
744601	Tray - Drain (Rear)	1	-
2177315	Cover - Hopper (E112 - LJS) (F112 - Auto Fill Kit)	-	-
2177316	Clip - Retaining (Mix Inlet) (Auto Fill Kit)	-	-
2177317	Mix Inlet Assembly (Auto Fill Kit)	-	-
2183642	Mix Inlet Assembly	1	-
2183721	Mix Inlet Assembly	-	1
2187039	Rack - Flavor Bottle (F112)	-	-
2187041	Rack - Flavor Bottle (E112)	-	-
2187918	Mix Inlet Assembly (LJS)	-	-
2187919	Clip - Retaining (Mix Inlet) (LJS)	-	-

8.4 MACHINE FRONT & SPIGOT SWITCH ASSEMBLY

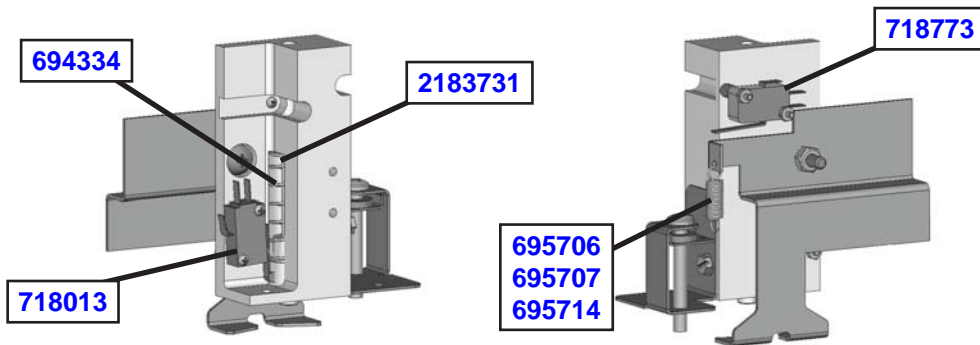
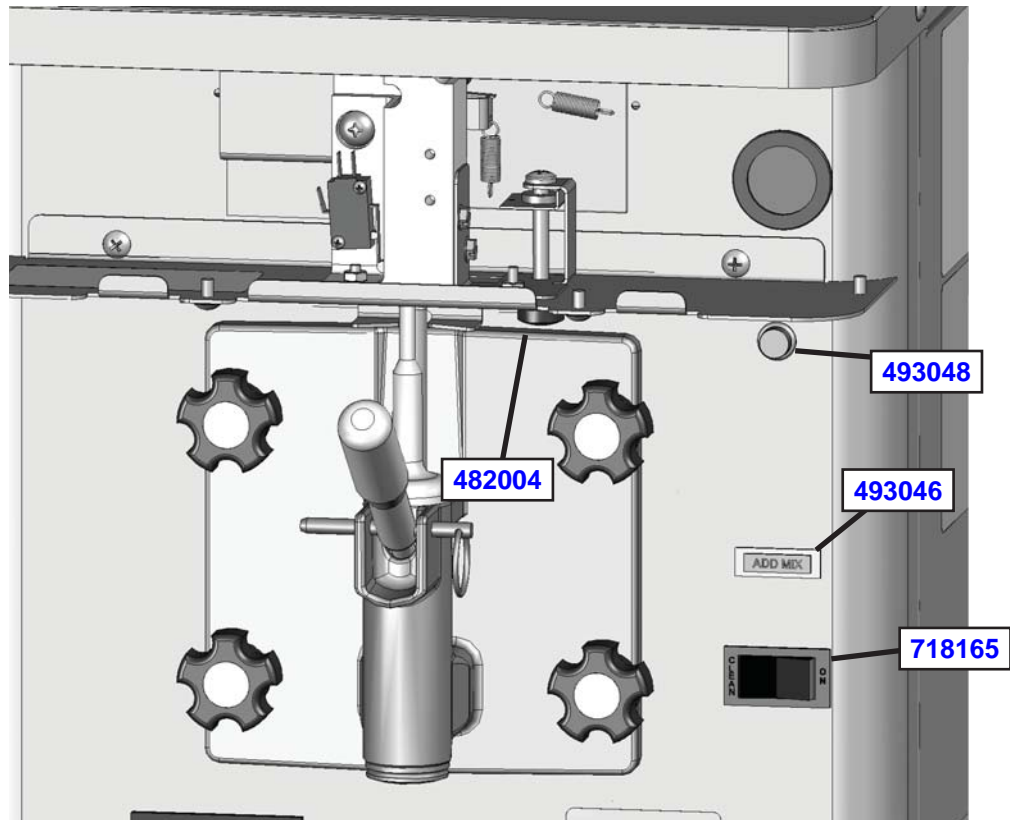

Part	Description	Quantity	
		E112	F112
482004	Knob (Consistency Adjustment)	1	1
493046	Light - Mix Low	1	1
493048	Light - Diagnostic (Round)	1	1
493057	Light - Diagnostic (Rectangular)	1	1
493080	Light - Mix Out (Rectangular)	1	
694334	Spring - Compression (Spigot Switch)	1	1
695706	Spring - Consistency Adjustment (Green)	1	
695707	Spring - Consistency Adjustment (Yellow)	1 (shake)	1
695714	Spring - Consistency Adjustment (Red)		1 (shake)
718013	Switch - Roller (Spigot)	1	1
718165	Switch - Rocker (Clean-Off-On)	1	1
718773	Switch - Limit (Torque Consistency)	1	1
2183459	Actuator - Spigot Switch (E112 - Ser. #0 - #23197)	1	
2183731	Actuator - Spigot Switch (E112 - Ser. #23198 Plus)	1	
2183851	Bracket - Drip Tray (E112 - Ser. #23377 Plus) (F112 - All)	1	1
7183303	Bracket - Drip Tray (E112 - Ser. #0 - #24586)	1	

8.5 E112 PARTS

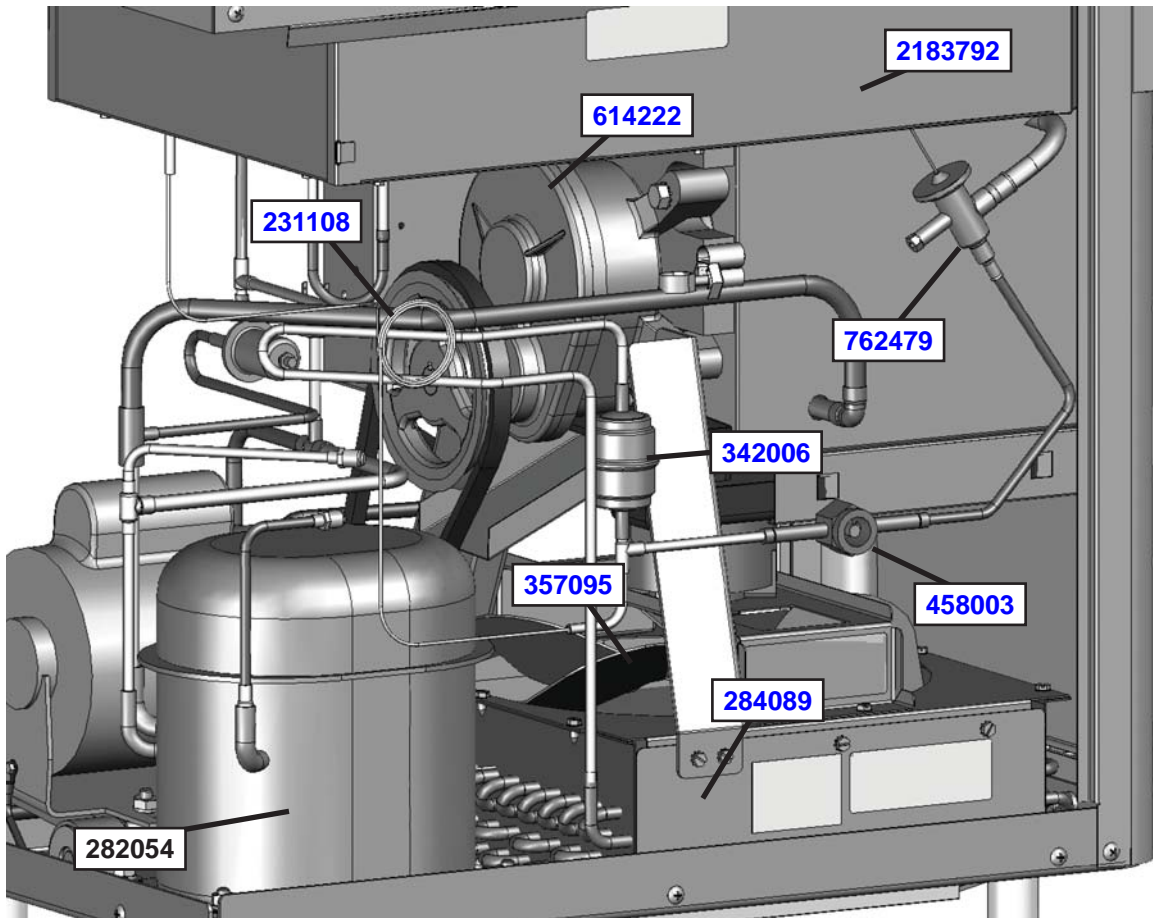
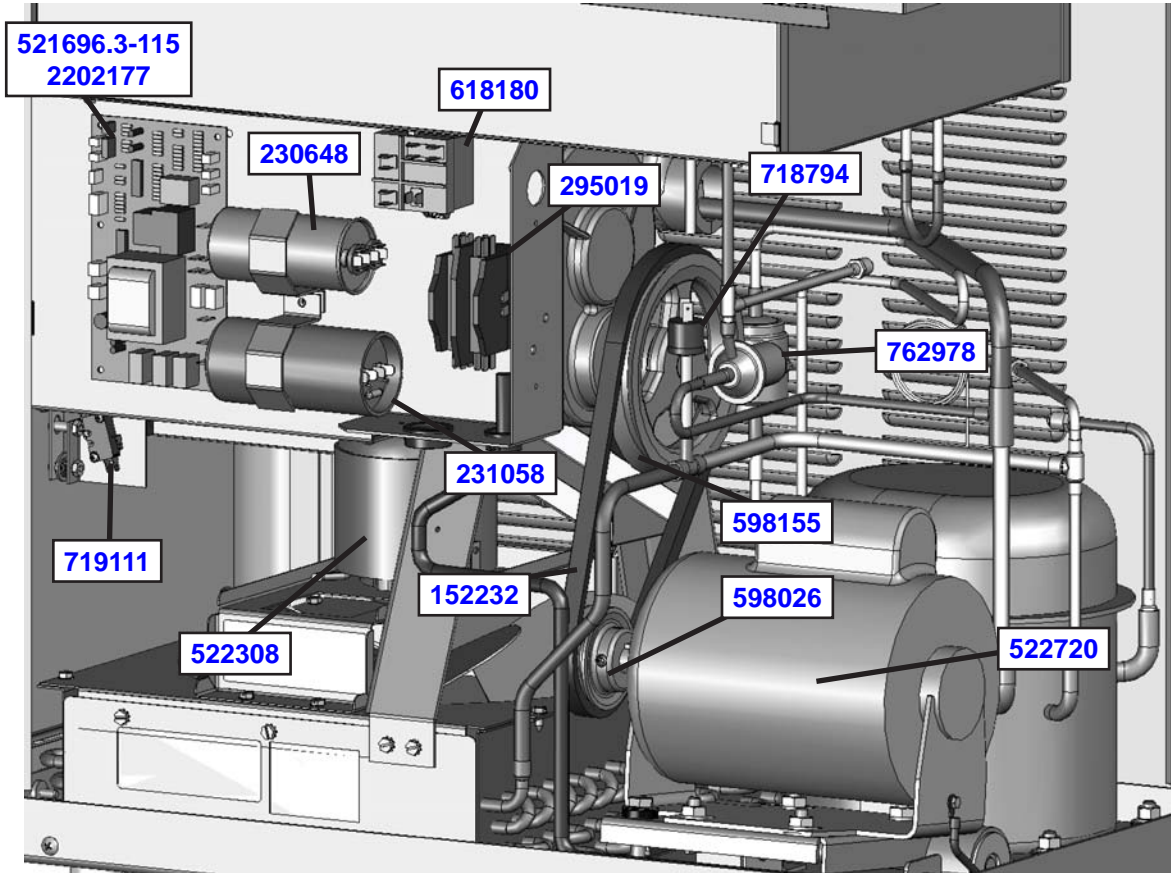

8.5 E112 PARTS - CONTINUED

Part	Description	E112 Qty.
152232	Belt - Grip-Notch (AX26) (E112 - Ser. #23377 Plus)	1
152233	Belt - Grip-Notch (AX28) (E112 - Ser. #0 - #23376)	1
230440	Capacitor (#522233 Drive Motor)	1
230648	Capacitor - Run (Compressor)	1
231058	Capacitor - Start (Compressor)	1
231101	Cap Tube Only (E112 - Ser. #0 - #23197)	1
231108	Cap Tube Only (E112 - Ser. #23198 Plus)	1
266196	Pin - Parts Safety (LJS)	-
282054	Compressor (No Capacitors)	1
284088	Condenser - Air-Cooled (E112 - Ser. #0 - #22767)	1
284089	Condenser - Air-Cooled (E112 - Ser. #22768 Plus)	1
295019	Contacto (45CG20AF)	1
342006	Drier	1
357093	Blade - Fan (Air-Cooled Condenser) (E112 - Ser. #0 - #23197)	1
357095	Blade - Fan (Air-Cooled Condenser) (E112 - Ser. #23198 Plus)	1
368397	Filter (2 Required)	2
458003	Indicator - Liquid Line	1
521696.3-115	Program Control Board (Use #2202177 if #295019 Contacto Not Installed)	1
522233	Motor - Drive - 1/2 HP (E112 - Ser. #0 - #23376)	1
522308	Fan Motor - Condenser	1
522720	Motor - Drive - 1/3 HP (E112 - Ser. #23377 Plus)	1
598026	Pulley - Drive Motor (E112 - Ser. #23377 Plus)	1
598027	Pulley - Drive Motor (E112 - Ser. #0 - #23376)	1
598155	Pulley - Speed Reducer	1
614222	Speed Reducer	1
618180	Relay (Compressor)	1
649200	Spring - Door Interlock	1
718537	Switch - Limit (Door Interlock) (E112 - Ser. #0 - #23494)	1
718794	Switch - High Pressure Reset	1
719111	Switch - Limit (Door Interlock) (E112 - Ser. #23495 Plus)	1
756067	Tubing - 1/4" ID (LJS) (Per Inch) (Auto Fill Kit)	-
762479	Valve - Expansion	1
762978	Valve - EPR	1
763664	Valve - Solenoid (LJS) (Auto Fill Kit)	-
1170836-SV	Switch Assembly - Limit (Door Interlock) (E112 - Ser. #0 - #23494)	1
2183792	Evaporator Assembly (E112 - Ser. #22768 Plus)	1
2202177	Program Control Board Kit (Use #521696.3-115 if #295019 Contacto Installed)	-
7183311	Evaporator Assembly (E112 - Ser. #0 - #22767)	1

8.6 F112 PARTS

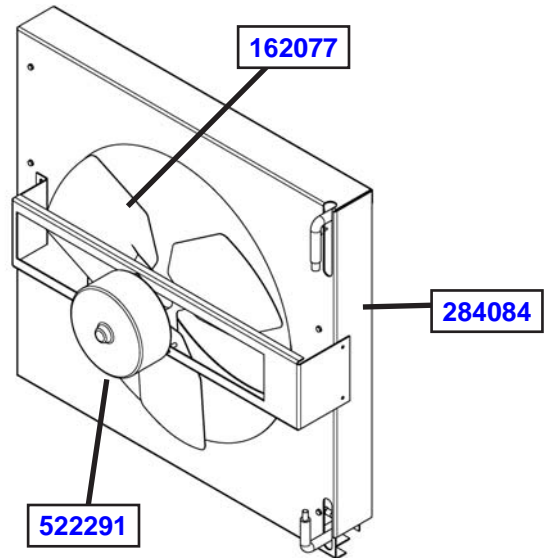
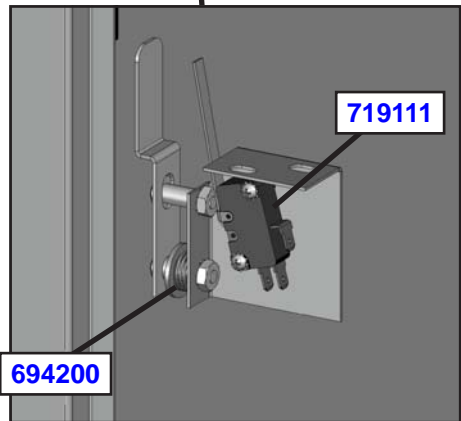
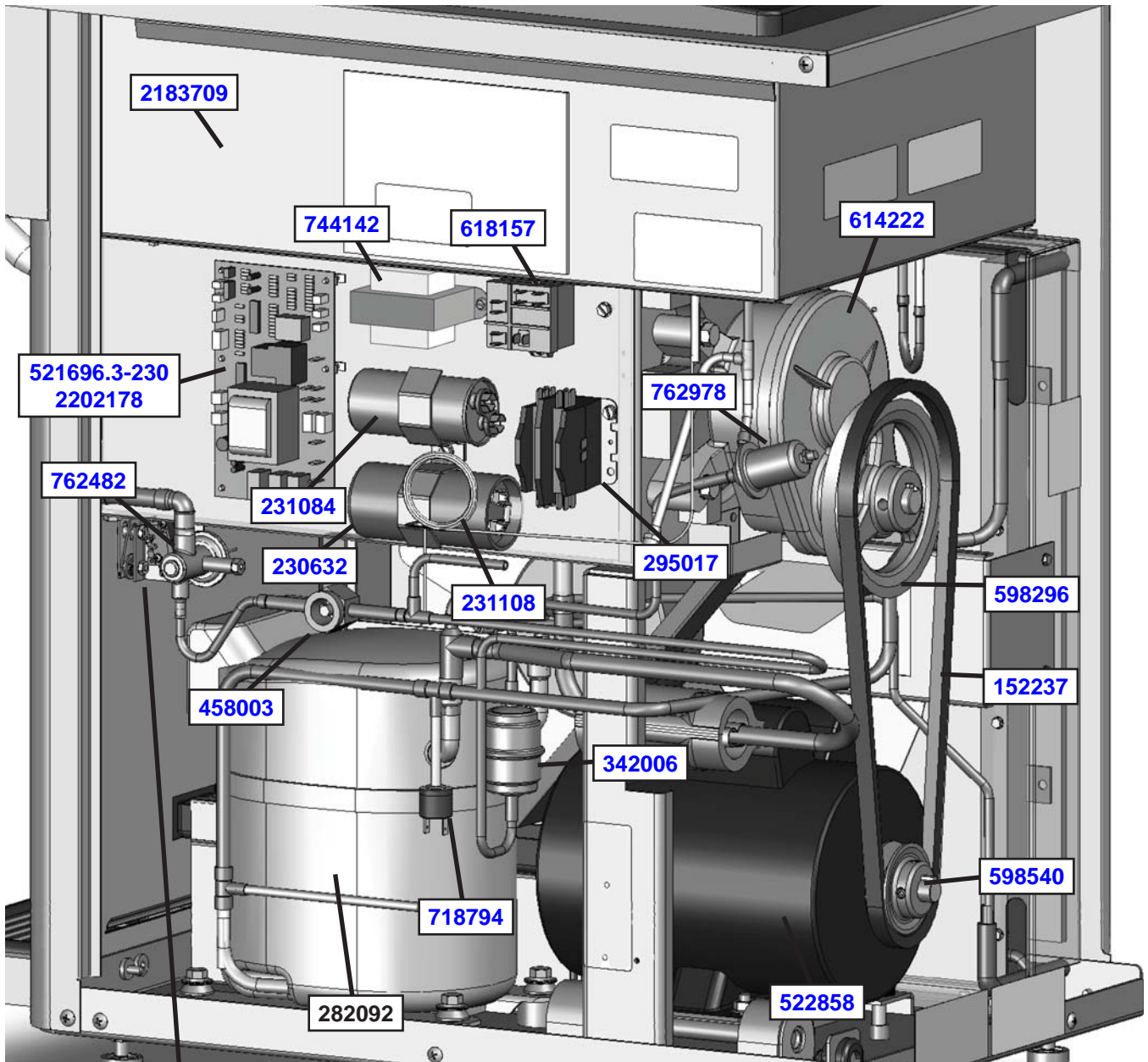

8.6 F112 PARTS - CONTINUED

Part	Description	F112 Qty.
152237	Belt - Grip-Notch (AX35)	1
162077	Blade - Fan (Air-Cooled Condenser)	1
230632	Capacitor - Start (#282045 Compressor)	1
231027	Capacitor - Run (#282052 Compressor)	1
231042	Capacitor - Start (#282052 Compressor)	1
231078	Capacitor - Run (#522858 Motor)	1
231084	Capacitor - Run (#282045 Compressor)	1
231095	Capacitor - Start (#522858 Motor)	1
231108	Cap Tube Only	1
264235	Clamp - Metal (1/4" I.D. Tubing) (Auto Fill Kit)	-
282052	Compressor - 50 Hz - R404A (No Capacitors)	-
282092	Compressor - 60 Hz - R404A (No Capacitors)	1
284084	Condenser (Air-Cooled)	1
284104	Condenser (Water-Cooled)	1
295017	Contactora (45CG20AG)	1
342006	Drier	1
368140	Filter - Air (Condenser)	1
458003	Indicator - Liquid Line	1
521696.3-230	Program Control Board (Use #2202178 if #295017 Contactora Not Installed)	1
522291	Motor - Fan	1
522858	Motor - Drive	1
598296	Pulley - Speed Reducer	1
598540	Pulley - Drive Motor	1
614222	Speed Reducer	1
618142	Relay - Start (#282052 Compressor)	-
618157	Relay - Start (#282045 Compressor)	1
694200	Spring - Door Interlock	1
718794	Switch - High Pressure Reset	1
719111	Switch - Limit (Door Interlock)	1
744142	Transformer (Auto Fill Kit)	-
756067	Tubing - 1/4" ID (Auto Fill Kit)	-
762482	Valve - Expansion	1
762978	Valve - EPR	1
763181	Valve - Water	1
763458	Valve - Solenoid (Auto Fill Kit)	-
2183709	Evaporator Assembly (Non A & W)	1
2187430	Kit - Side Mounting Rack (A&W Only)	-
2187546	Evaporator Assembly (A&W Only)	-
2202178	Program Control Board Kit (Use #521696.3-230 if #295017 Contactora Installed)	-

8.7 RETROFIT KITS

The E112 and F112 retrofit kits have a redesigned torque switch bracket. The kits also replace the consistency adjustment knob with an adjustment screw.

Note: If the machine has been retrofitted, there will not be a consistency adjustment knob visible from the front of the machine.

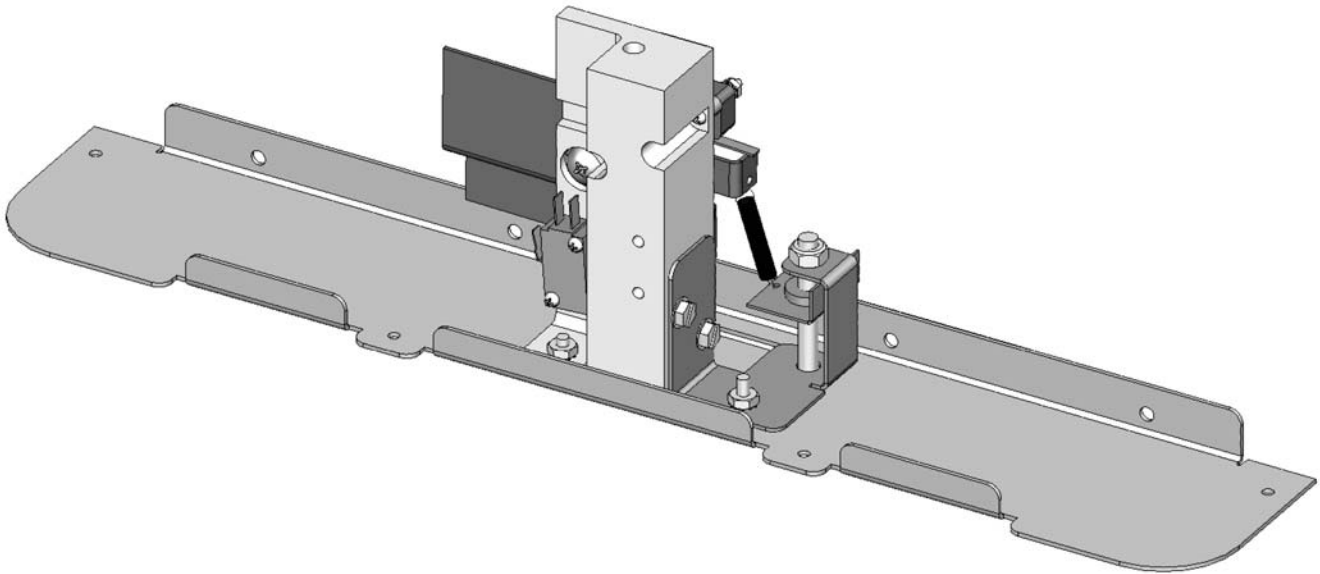

Following are the parts required for the retrofit kit:

E112 (SER. #0 - #22767)

Part	Description	Quantity
630053	Rod - Torque Actuator	1
2183739	Spigot Body	1
2187512	Kit - Header Panel Retrofit	1
2187557	Stator Bar	1

E112 (SER. #22768 - #23197)

Part	Description	Quantity
2183739	Spigot Body	1
2187512	Kit - Header Panel Retrofit	1
2187557	Stator Bar	1

E112 (SER. #23198 - #25947)

Part	Description	Quantity
2187512	Kit - Header Panel Retrofit	1

F112 (SER. #0 - #25501)

Part	Description	Quantity
2187513	Kit - Header Panel Retrofit	1
2187556	Stator Bar	1

8.8 REFRIGERATION DIAGRAM

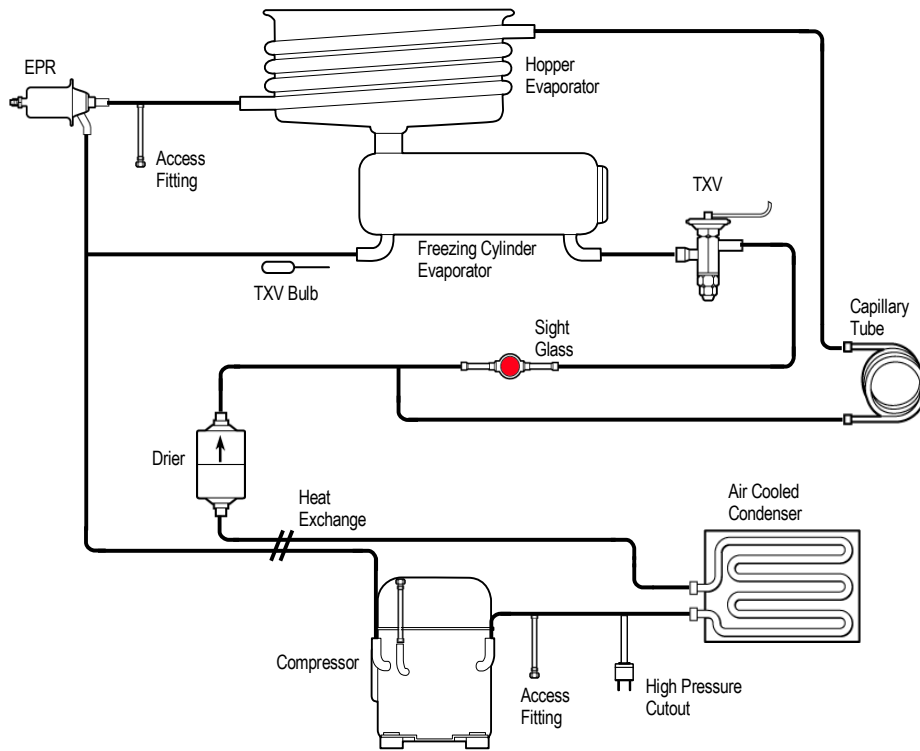

E112 Refrigeration Diagram

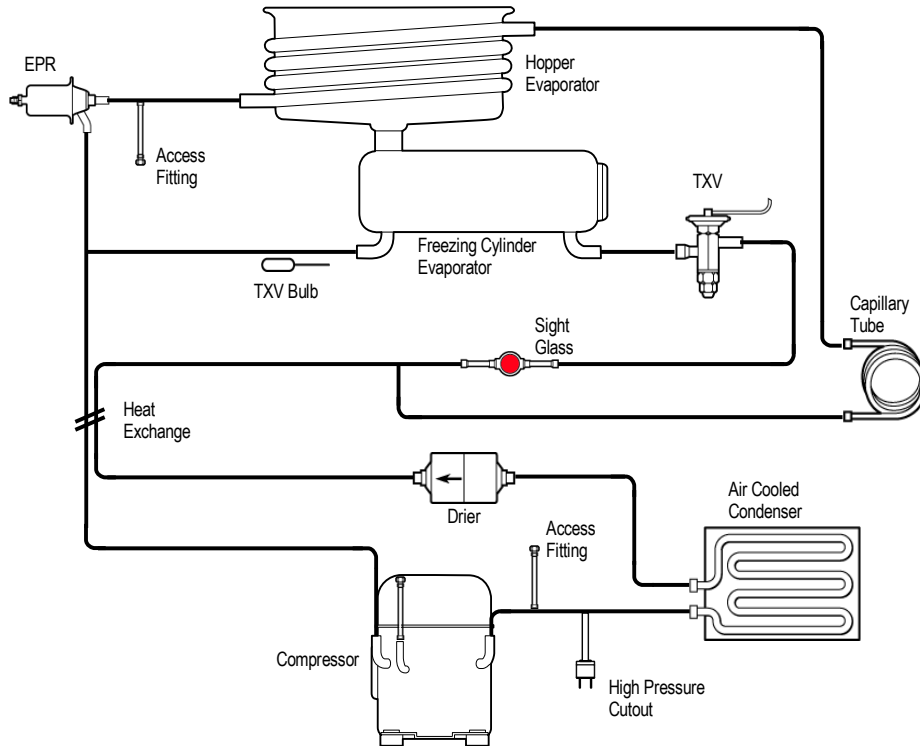

F112 Refrigeration Diagram

8.9 E112 WIRING DIAGRAM

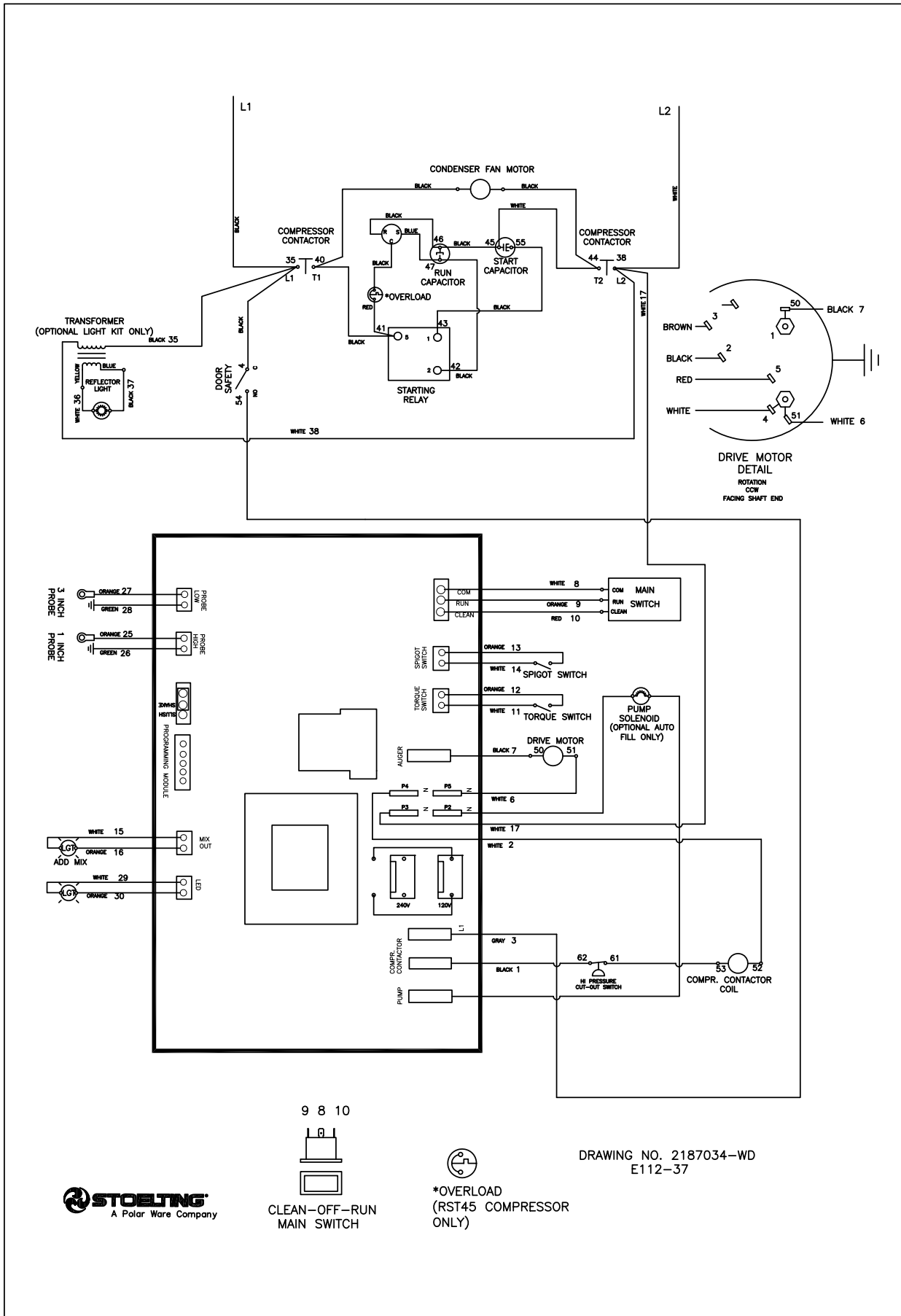

8.10 F112 WIRING DIAGRAM

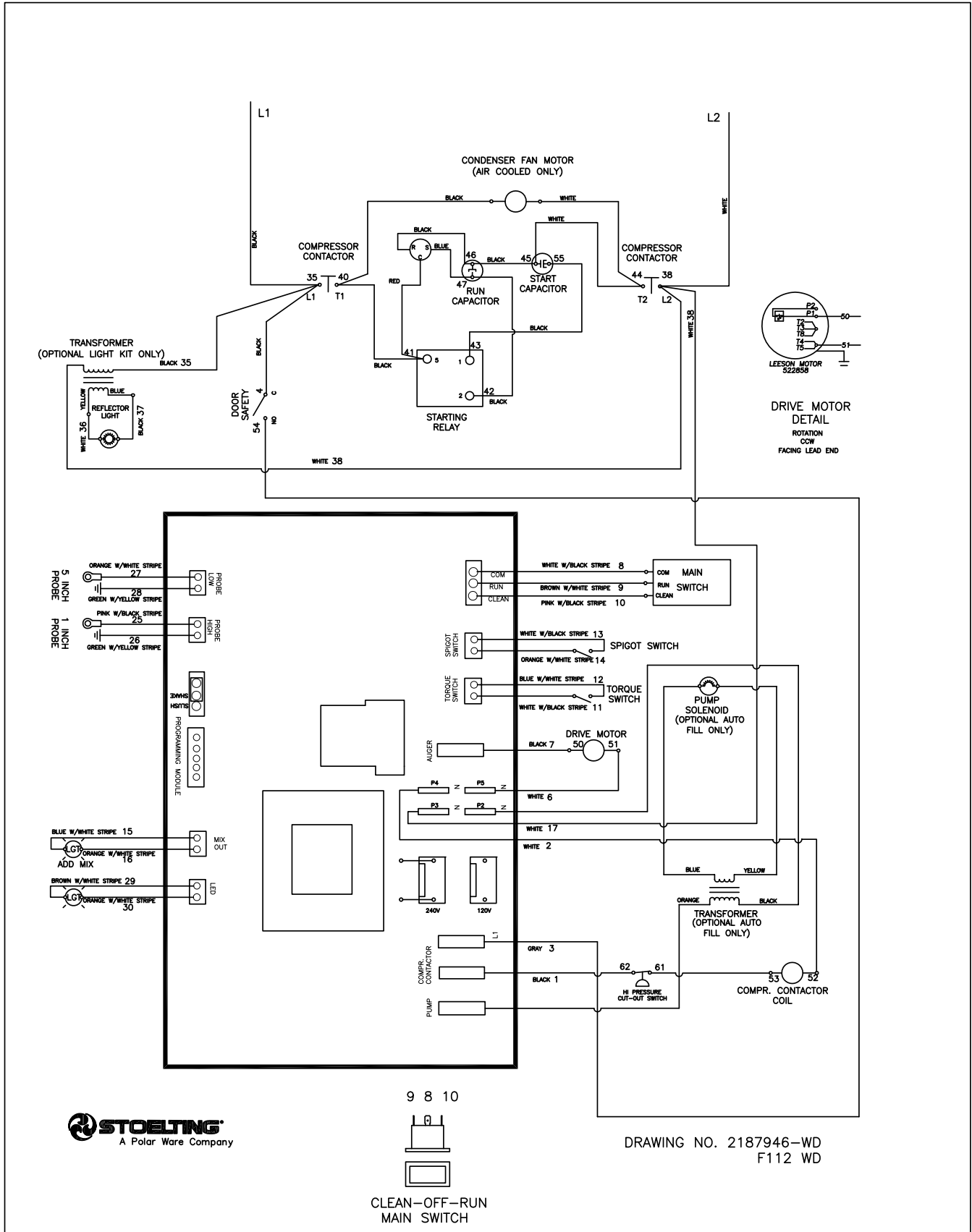

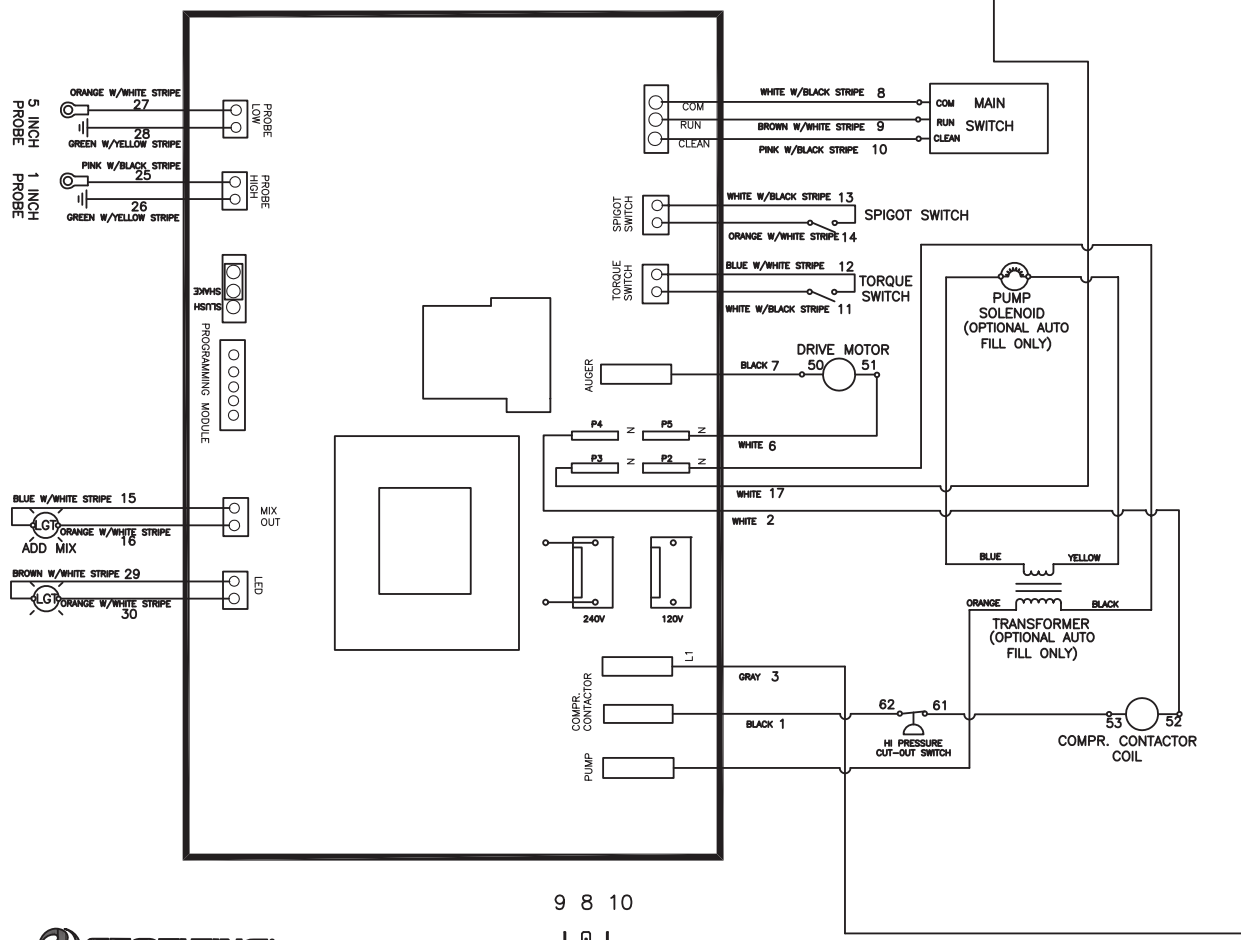
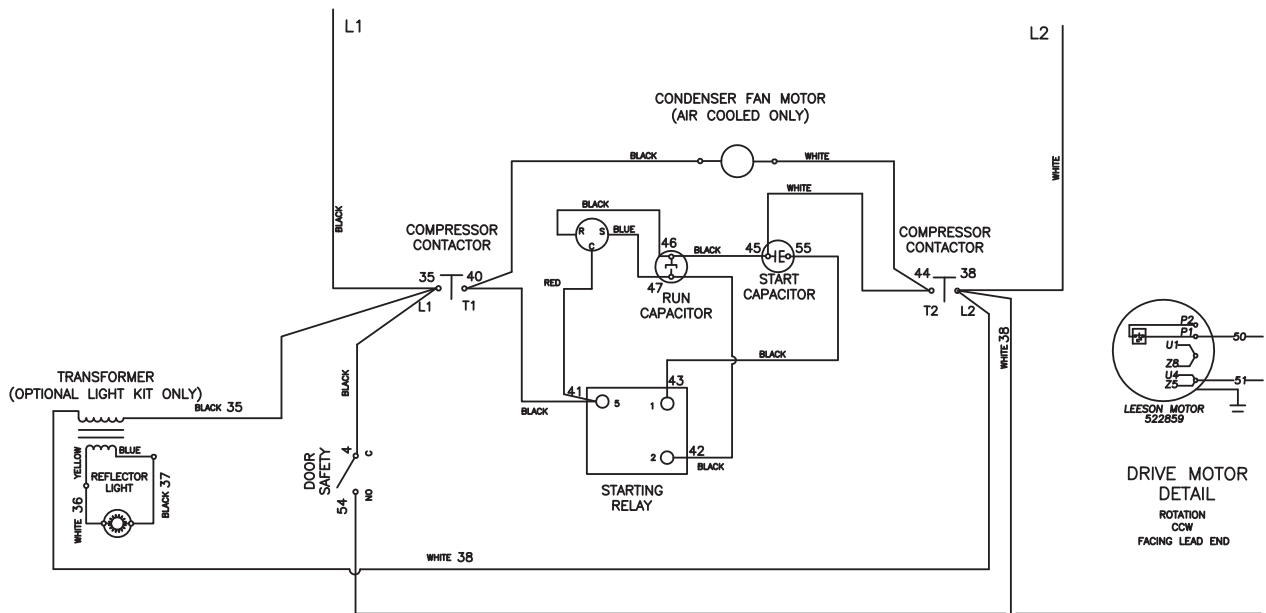

9 8 10



CLEAN-OFF-RUN MAIN SWITCH

DRAWING NO. 2187236-WD
F112-302
F112-102

8.11 AUTOFILL OPTIONS

The E112 and F112 machines can easily be configured to use an Autofill System. The Autofill System provides a constant supply of non-dairy mix to the machine.

AUTOFILL KIT

An autofill kit is needed to use an Autofill System. The kit includes a solenoid, tubing, and a new hopper cover (the F112 also includes a transformer). See below for the Autofill Kit part numbers.

AUTOFILL SYSTEMS

There are two Autofill Systems available: the Fill-O-Matic II and the Fill-O-Matic III. See below for details on the Autofill Systems.

Fill-O-Matic II

The Fill-O-Matic II is powered through an electrical outlet and pumps up to 60 gallons per hour.

Fill-O-Matic III

The Fill-O-Matic III is powered by gas and pumps up to 45 gallons per hour.



Fill-O-Matic II & Fill-O-Matic III

Fill-O-Matic II	
Part Numbers	Autofill System: 4177349 E112 Autofill Kit: 2183807 F112 Autofill Kit: 2187101
Usage	For use with non-potentially hazardous food substances; non-dairy
Dimensions	L 11-1/2" x W 11-1/2" x H 32-1/2"
Electrical	115VAC 60Hz 15A power cord provided
Mix Storage	15 gallon plastic tank
Clean Process	Removable strainer allows for easy cleaning
Output	Pumps up to 60 gallons per hour

Fill-O-Matic III	
Part Numbers	Autofill System: 4177370 E112 Autofill Kit: 2183807 F112 Autofill Kit: 2187101
Usage	For use with non-potentially hazardous food substances; non-dairy
Dimensions	L 11-1/2" x W 11-1/2" x H 27-1/2"
Electrical	No electrical connections required Powered by CO ₂ , Nitrogen or compressed air
Mix Storage	15 gallon plastic tank
Clean Process	Clean-in-place by pumping solution through hoses
Output	Pumps up to 45 gallons per hour



**DOMESTIC WARRANTY
(Including Mexico)
SOFT SERVE / SHAKE EQUIPMENT**

1. **Scope:**
PW Stoelting, L.L.C. (“Stoelting”) warrants to the first user (the “Buyer”) that the freezing cylinders, hoppers, compressors, drive motors, speed reducers, and augers of Stoelting soft serve / shake equipment will be free from defects in materials and workmanship under normal use and proper maintenance appearing within five (5) years, and that all other components of such equipment manufactured by Stoelting will be free from defects in material and workmanship under normal use and proper maintenance appearing within twelve (12) months after the date that such equipment is originally installed.

2. **Disclaimer of Other Warranties:**

THIS WARRANTY IS EXCLUSIVE; AND STOELTING HEREBY DISCLAIMS ANY IMPLIED WARRANTY OF MERCHANTABILITY OR FITNESS FOR PARTICULAR PURPOSE.

3. **Remedies:**
Stoelting’s sole obligations, and Buyer’s sole remedies, for any breach of this warranty shall be the repair or (at Stoelting’s option) replacement of the affected component at Stoelting’s plant in Kiel, Wisconsin, or (again, at Stoelting’s option) refund of the purchase price of the affected equipment, and, during the first twelve (12) months of the warranty period, deinstallation/reinstallation of the affected component from/into the equipment. Those obligations/remedies are subject to the conditions that Buyer (a) signs and returns to Stoelting, upon installation, the Start-Up and Training Checklist for the affected equipment, (b) gives Stoelting prompt written notice of any claimed breach of warranty within the applicable warranty period, and (c) delivers the affected equipment to Stoelting or its designated service location, in its original packaging/crating, also within that period. Buyer shall bear the cost and risk of shipping to and from Stoelting’s plant or designated service location.

4. **Exclusions and Limitations:**
This warranty does not extend to parts, sometimes called “wear parts”, which are generally expected to deteriorate and to require replacement as equipment is used, including as examples but not intended to be limited to o-rings, auger flights, auger seals, auger support bushings, and drive belts. All such parts are sold

AS IS.

Further, Stoelting shall not be responsible to provide any remedy under this warranty with respect to any component that fails by reason of negligence, abnormal use, misuse or abuse, use with parts or equipment not manufactured or supplied by Stoelting, or damage in transit.

THE REMEDIES SET FORTH IN THIS WARRANTY SHALL BE THE SOLE LIABILITY STOELTING AND THE EXCLUSIVE REMEDY OF BUYER WITH RESPECT TO EQUIPMENT SUPPLIED BY STOELTING; AND IN NO EVENT SHALL STOELTING BE LIABLE FOR ANY INCIDENTAL OR CONSEQUENTIAL DAMAGES, WHETHER FOR BREACH OF WARRANTY OR OTHER CONTRACT BREACH, NEGLIGENCE OR OTHER TORT, OR ON ANY STRICT LIABILITY THEORY.