



Model E122 & F122
SERVICE MANUAL

Manual No. 513668

Rev.0

This manual provides basic information about the machine. Instructions and suggestions are given covering its operation and care.

The illustrations and specifications are not binding in detail. We reserve the right to make changes to the machine without notice, and without incurring any obligation to modify or provide new parts for machines built prior to date of change.

DO NOT ATTEMPT to operate the machine until instructions and safety precautions in this manual are read completely and are thoroughly understood. If problems develop or questions arise in connection with installation, operation, or servicing of the machine, contact Stoelting.



stoeltingfoodservice.com

Stoelting Foodservice Equipment
502 Highway 67
Kiel, WI 53042-1600
U.S.A.

White Glove Service Network
Phone: 888.319.9549

© 2017 Stoelting

A Few Words About Safety

Safety Information

Read and understand the entire manual before operating or maintaining Stoelting equipment.

This manual provides the operator with information for the safe operation and maintenance of Stoelting equipment. As with any machine, there are hazards associated with their operation. For this reason safety is emphasized throughout the manual. To highlight specific safety information, the following safety definitions are provided to assist the reader.

The purpose of safety symbols is to attract your attention to possible dangers. The safety symbols, and their explanations, deserve your careful attention and understanding. The safety warnings do not by themselves eliminate any danger. The instructions or warnings they give are not substitutes for proper accident prevention measures.

If you need to replace a part, use genuine Stoelting parts with the correct part number or an equivalent part. We strongly recommend that you do not use replacement parts of inferior quality.



Safety Alert Symbol:

This symbol Indicates danger, warning or caution. Attention is required in order to avoid serious personal injury. The message that follows the symbol contains important information about safety.

Signal Word:

Signal words are distinctive words used throughout this manual that alert the reader to the existence and relative degree of a hazard.



The signal word “WARNING” indicates a potentially hazardous situation, which, if not avoided, may result in death or serious injury and equipment/property damage.



The signal word “CAUTION” indicates a potentially hazardous situation, which, if not avoided, may result in minor or moderate injury and equipment/property damage.

CAUTION

The signal word “CAUTION” not preceded by the safety alert symbol indicates a potentially hazardous situation, which, if not avoided, may result in equipment/property damage.

NOTE (or NOTICE)

The signal word “NOTICE” indicates information or procedures that relate directly or indirectly to the safety of personnel or equipment/property.

TABLE OF CONTENTS

Section	Description	Page
1	Description and Specifications	
1.1	Description.....	1
1.2	Specifications	2
1.3	Component Settings	4
1.4	Modes of Normal Operation	5
1.5	Operation During an Error Mode	6
2	Maintenance and Adjustments	
2.1	Accessing Control Readings and Settings	9
2.2	Navigation and Modifying Settings	9
2.3	User Interface Screens.....	9
2.4	Performance Screens.....	10
2.5	Settings Screens	10
2.6	Utilities Screens.....	12
2.7	Errors and Statistics Screens	14
2.8	Product Consistency Adjustment.....	17
2.9	Drive Belt Tension Adjustment.....	17
2.10	Preventative Maintenance.....	17
2.11	Extended Storage.....	18
3	Refrigeration and Wiring Diagrams	
3.1	Refrigeration Diagram	19
3.2	Wiring Diagrams.....	20
4	Replacement Parts	
4.1	Decals and Lubrications	29
4.2	Auger Shaft and Faceplate Parts	30
4.3	Hopper Parts	31
4.4	Motor Components.....	32
4.5	Spigot Assembly.....	32
4.6	Panels and Screws.....	33
4.7	Kits and Miscellaneous.....	33
4.8	Electrical Components.....	34
4.9	Refrigeration	36
4.10	Auto Fill Parts	38

SECTION 1

DESCRIPTION AND SPECIFICATIONS

1.1 DESCRIPTION

The Stoelting E122 & F122 countertop machines are gravity fed. The machines are equipped with fully automatic controls to provide a uniform product. This manual is designed to help qualified service personnel and operators with the installation, operation and maintenance of the Stoelting E122 & F122 gravity machines.

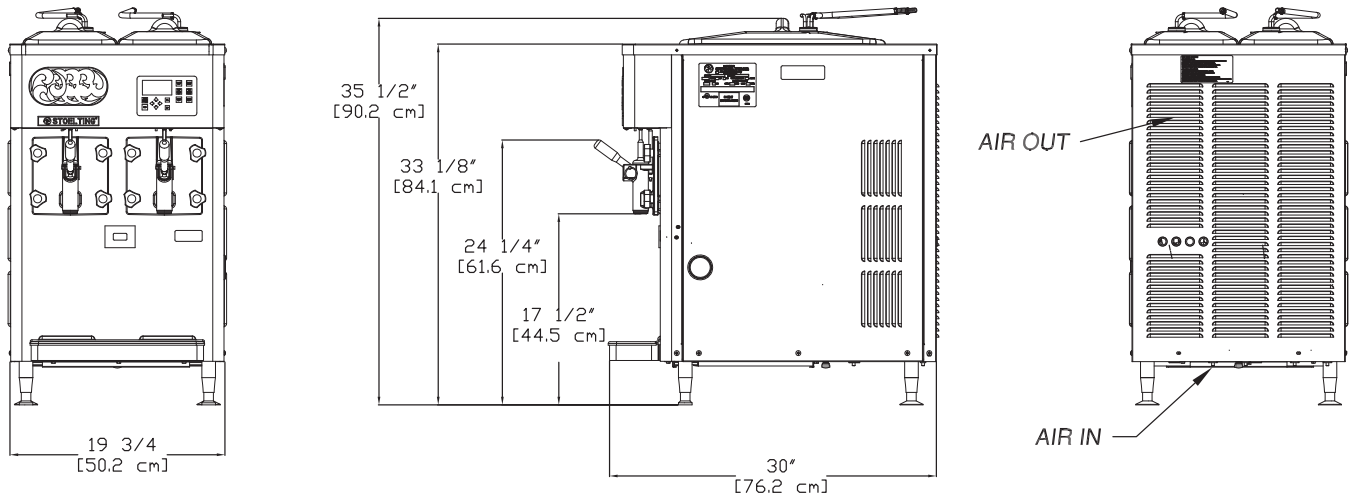

Figure 1-1 Model E122



Figure 1-2 Model F122

1.2 SPECIFICATIONS



	Model E122	
Dimensions	Machine	with crate
width	19-5/8" (49,8 cm)	28-1/2" (72,4 cm)
height	35-1/2" (90,2 cm)	44" (111,8 cm)
depth	30-1/4" (76,8 cm)	36" (91,4 cm)
Weight	275 lbs (124,7 kg)	278 lbs (126,0 kg)
Electrical	1 Phase, 208-240 VAC, 60Hz	
running amps	10.6A	
connection type	NEMA6-15P power cord provided	
Compressor	5,500 Btu/hr	
Drive Motor	Two - 1/3 hp	
Air Flow	Air cooled units require 4" (10,2 cm) air space in back	
Plumbing Fittings	Water cooled units require 3/8" N.P.T. water and drain fittings. Maximum water pressure of 130 psi. Minimum water flow rate of 3 GPM per barrel. Ideal EWT of 50°-70°F.	
Hopper Volume	Two - 3 gallon (11,36 liters)	
Freezing Cylinder Volume	Two - 2.125 gallon (8,04 liters)	

	E122
Refrigerant	R-404A
Charge	30 oz
Suction Pressure (at 80-85°F)	23-26 psig
Discharge Pressure	270 psig
Hot Gas Bypass Pressure	18 psig
EPR Valve	68-70 psig

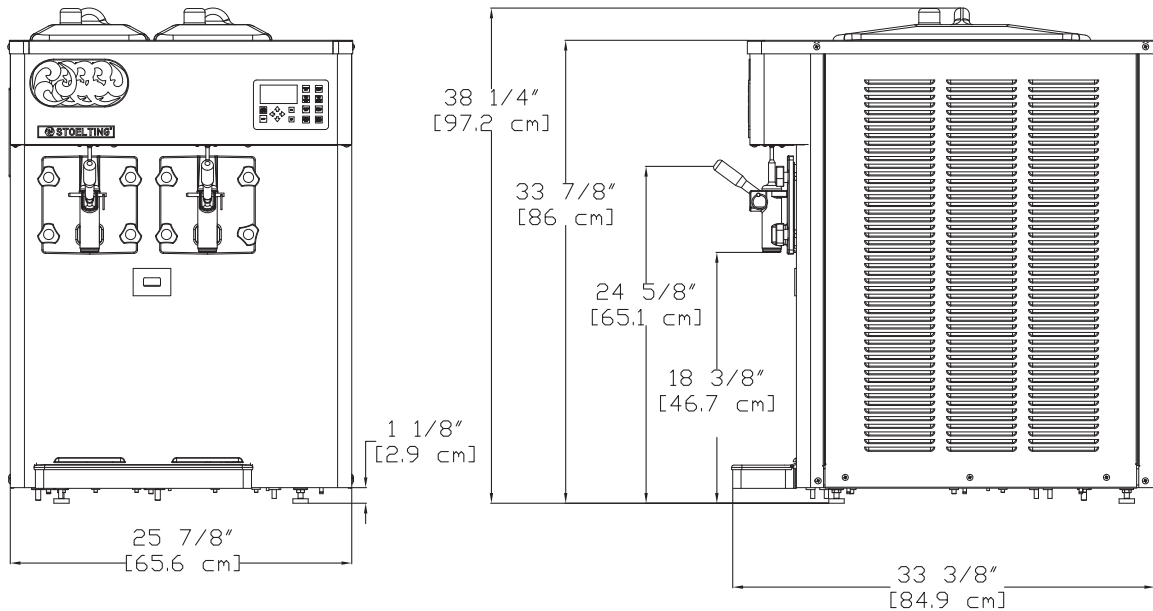

Model F122		
Dimensions	Machine	with crate
width	25-7/8" (65,7 cm)	31-3/4" (80,6 cm)
height	38-1/4" (97,2 cm)	47-3/8" (120,3 cm)
depth	33-3/8" (84,8 cm)	41-1/4" (104,8 cm)
Weight	390 lbs (176,9 kg)	458 lbs (207,7 kg)
Electrical	1 Phase, 208-240 VAC, 60Hz	
running amps	14.5A	
connection type	NEMA6-20P power cord provided	
Compressor	12,000 Btu/hr	
Drive Motor	Two - 1/2 hp	
Air Flow	Air cooled units require 6" (15,24 cm) air space on both sides	
Plumbing Fittings	Water cooled units require 3/8" N.P.T. water and drain fittings. Maximum water pressure of 130 psi. Minimum water flow rate of 3 GPM per barrel. Ideal EWT of 50°-70°F.	
Hopper Volume	Two - 3 gallon (11,36 liters)	
Freezing Cylinder Volume	Two - 2.125 gallon (8,04 liters)	

	F122
Refrigerant	R-404A
Charge	40 oz
Suction Pressure (at 72°F)	34 psig
Discharge Pressure	225-235 psig
Hot Gas Bypass Pressure	14 psig
EPR Valve	68-70 psig

1.2 SPECIFICATIONS (CONTINUED)

PEAK HEAT OF REJECTION

Model	Electrical	Peak Heat of Rejection	Water Cooled Only		Air Cooled Only
			Peak Water Usage	Estimated Water Usage	AC Load Rating
E122	1 PH, 60Hz	11,511 BTU/hr	2.3 GPM	1.4 GPM	8,850 BTU/hr
F122	1 PH, 50Hz	14,947 BTU/hr	3.0 GPM	1.9 GPM	11,721 BTU/hr

1.3 COMPONENT SETTINGS

Following are the settings for the components in the E122 & F122 machines.

A. COMPRESSOR WINDINGS

When testing the compressor windings the resistance through the windings should be as follows:

F122

Compressor	Electrical	S to C	R to C
282032-SV	1 PH 60Hz	3.10Ω	1.16Ω
282050	1 PH 50Hz	3.79Ω	1.39Ω

E122

Compressor	Electrical	S to C	R to C
282094	1 PH 60Hz	5.94Ω	1.18Ω

B. CAPACITORS

Refer to the following table for the capacitance of all the capacitors in the machine:

F122

Capacitor	Part	Rating	
		MFD	VAC
Comp - Run (50/60 Hz)	231084	30 MFD	370 VAC
Comp - Start (60 Hz)	231079	145-174 MFD	220 VAC
Comp - Start (50 Hz)	230649	130-156 MFD	250 VAC
Drive Motor - Run	230687	30 MFD	370 VAC
Drive Motor - Start	230685	645-774 MFD	125 VAC
Fan Motor	230654	5 MFD	400 VAC

E122

	Part	Rating	
		MFD	VAC
Compressor - Run	230666	20 MFD	440 VAC
Compressor - Start	230632	72-86 MFD	330 VAC
Drive Motor - Start	230447	189-227 MFD	165 VAC
Fan Motor	230665	88-106 MFD	330 VAC

C. TEMPERATURE CONTROL SENSOR

The following table shows the relationship between the thermistor resistance and the suction line temperature.

°F	Resistance	°F	Resistance
-22	176950	40	26100
-20	165200	42	24725
-18	154300	44	23400
-16	144200	46	22175
-14	134825	48	21000
-12	126125	50	19900
-10	118050	52	18875
-8	110550	54	17900
-6	103550	56	17000
-4	97075	58	16125
-2	91025	60	15325
0	85400	62	14550
2	80150	64	13825
4	75275	66	13150
6	70725	68	12500
8	66475	70	11875
10	62500	72	11300
12	58800	74	10750
14	55325	76	10250
16	52100	78	9750
18	49075	80	9300
20	46250	82	8850
22	43600	84	8450
24	41125	86	8050
26	38800	88	7675
28	36625	90	7325
30	34575	92	7000
32	32675	94	6675
34	30875	96	6375
36	29175	98	6100
38	27600	100	5825

1.4 MODES OF NORMAL OPERATION

Following is an explanation of the normal operation modes on the E122 and F122 (Refer to Figure 1-3).

NOTE

The machine uses the torque switch to maintain product consistency. The IntelliTec2™ controls the timers which include Pre Stir, Post Stir and Off Time (standby).

A. PRE STIR

When the Push To Freeze button is pressed or when the spigot is opened, the drive motor starts a 5-second pre stir. The torque switch determines if a freezing cycle begins. If the consistency of the product holds the torque switch closed for 3 seconds the machine goes to Standby. Otherwise a freezing cycle begins.

B. FREEZING CYCLE

The freezing cycle runs until the torque rod closes the torque switch and keeps the switch closed for 3 seconds. If product consistency is not met within 20 minutes, the machine operates in the compressor time out mode (See Section 1.5).

NOTE

If the spigot is pulled during a freezing cycle, the 20-minute timer restarts.

C. POST STIR

After the freezing cycle ends, the drive motor continues to run for a 12 second post stir. The post stir ensures the product does not freeze to the cylinder. If the spigot is opened during the post stir, the machine checks consistency. If the product is at consistency, the machine goes to standby. If the product is not at consistency, the machine starts a freezing cycle.

D. STANDBY

The machine remains in Standby for 5 minutes or until the spigot is pulled. At the end of Standby the machine goes to Pre Stir if the cycle count has not been met. If the cycle count has been met it goes to Refrigerate Mode.

E. REFRIGERATE MODE

After the cycle count is met without a spigot pull, the machine is in Refrigerate Mode. It remains in refrigerate mode until the spigot is pulled.

F. CLEAN MODE

When the Clean button is pressed, the drive motor starts and runs for 20 minutes. After the 20 minutes expire, the drive motor stops and a Clean alert will be displayed on the IntelliTec2™. To clear the alert, press the On/Off button for the cylinder to turn it off then press it again to turn it on.

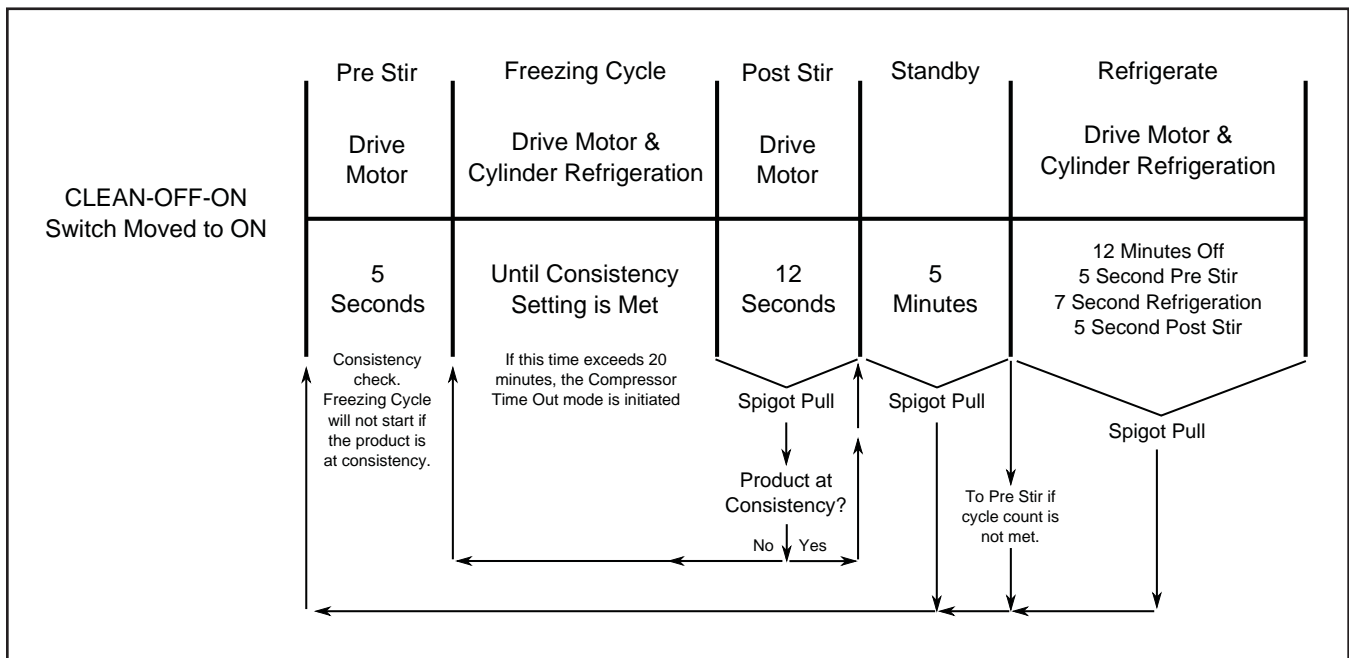

Figure 1-3 Modes of Normal Operation

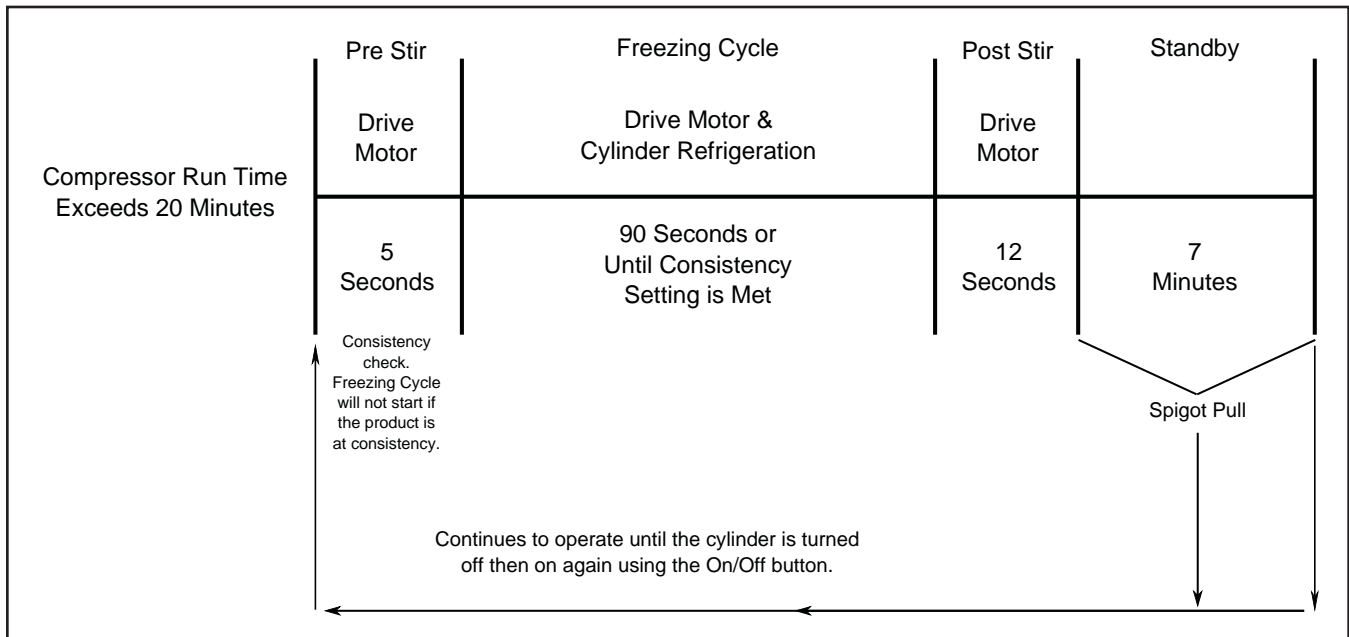

Figure 1-4 Compressor Time Out Mode

1.5 OPERATION DURING AN ERROR MODE

A. COMPRESSOR TIME OUT MODE

If the freezing cycle exceeds 20 minutes, the machine operates on timers (Refer to Figure 1-4).

B. LOW MIX MODE

If the mix level falls below the sensor probe, the machine operates on timers. The machine continues to operate on timers until the mix level in the hopper is above the sensor probe (Refer to Figure 1-5).

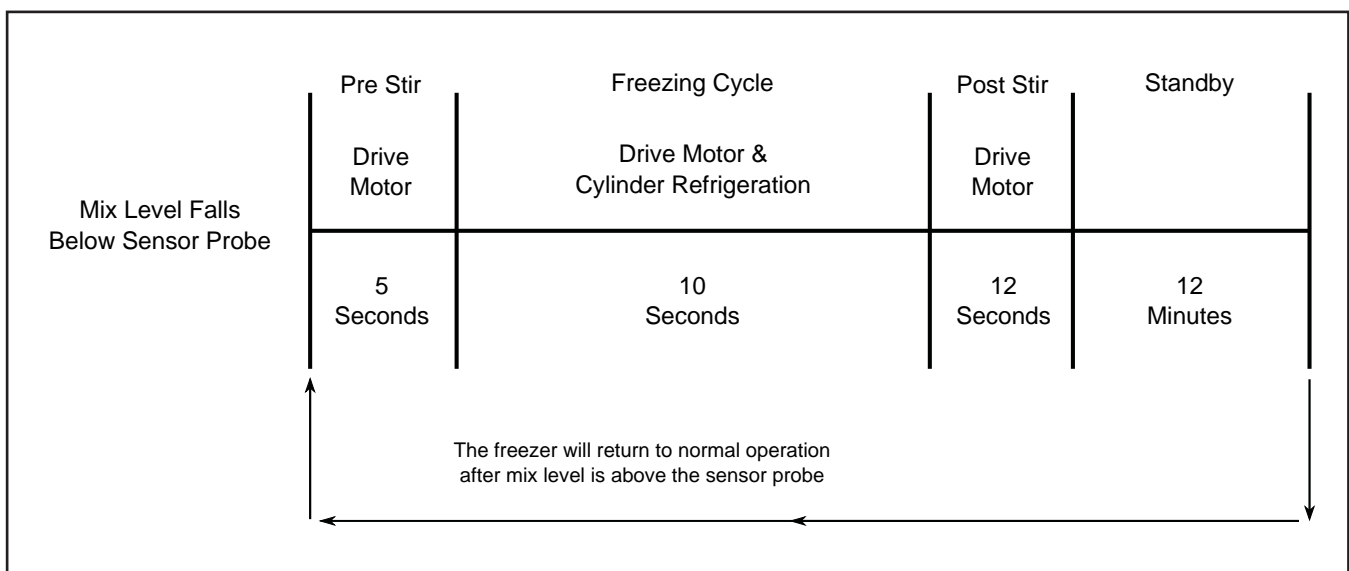

Figure 1-5 Low Mix Mode

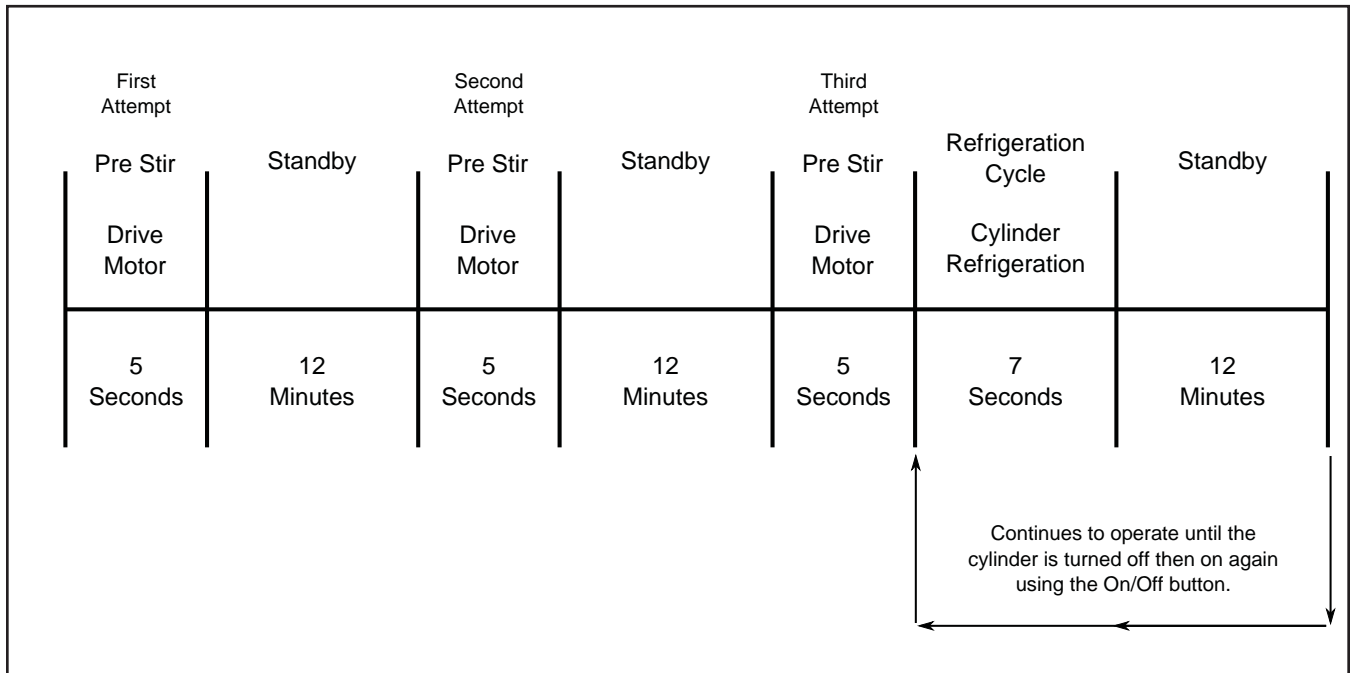

Figure 1-6 Drive Motor Error Mode

C. DRIVE MOTOR ERROR MODE

If the control does not sense current from the drive motor during a pre stir, the machine goes into standby mode for 12 minutes. After standby, the control repeats the pre stir and attempts to sense drive motor current. After the third pre stir without sensing drive motor current, the machine operates on timers. If the spigot is pulled during standby, the machine immediately attempts to sense drive motor current.

SECTION 2 MAINTENANCE AND ADJUSTMENTS

This section is intended to provide maintenance personnel with a general understanding of the machine adjustments. It is recommended that any adjustments be made by a qualified person.

NOTE

There are many settings in the IntelliTec2™ control that do not affect the operation of the E122 or F122. These settings will not be covered in this manual and should not be changed.

2.1 ACCESSING CONTROL READINGS AND SETTINGS

The readings and settings on the IntelliTec2™ control are accessed by using a keypad sequence. Press the left arrow button from the Current Status screen to access the passcode input screen.

The specific readings and parameters available depend on the keypad sequence entered. The lowest level is Associate and has limited access. The Manager level has access to the majority of screens except Utilities (2 of 2). The Technician and Factory levels have full access to the control including the Associate and Manager level options. The Factory level has an additional factory settings menu.

Following are the keypad sequences for the three levels available.

- | | |
|-------------------|---|
| Associate | Press the right arrow then the SEL button. |
| Manager | Press the right arrow, up arrow then the SEL button |
| Technician | Press the right arrow, SET, then the SEL button |
| Factory | Press the right arrow, down arrow, SET, up arrow then the SEL button. |

2.2 NAVIGATION AND MODIFYING SETTINGS

Navigating through the IntelliTec2™ screens is done with the arrow keys on the touchpad. After positioning the cursor on a desired menu, press the SEL button to select that option. To change a setting, press the SET button. Use the arrow keys to change the value. Press the SET button to save the changes.

The SEL button changes the cylinder selection on screens that show the cylinder.

Pressing the left arrow button from any menu will go back one screen. Pressing the left arrow button at the Main Menu screen goes to the Current Status screen.

2.3 USER INTERFACE SCREENS

A. CURRENT STATUS

Current Status	01/01/01 12:34:56
Left	Off
Right	Off
Storage Hoppers	Off
Left Hopper	Autofill On
Right Hopper	Autofill On
_ Service Company	

The Current Status screen gives an overview of the machine's operation. It shows the mode of the freezing cylinders, the storage refrigeration, and the status of the autofill system. If there is an error, the error text description replaces the status information.

The Service Contact Information screen is accessed from the Current Status screen. Move the cursor to the Service Contact Information option and press the SEL button.

B. SERVICE CONTACT INFORMATION

Service Contact Information	
Name	Stoelting
Telephone Number	800 - 319 - 9549
Unit Serial Number	1234567AA
Version	00.00/00.00

The Service Contact Information screen provides the name and telephone number for service. The default is Stoelting White Glove Service. The default can be changed by selecting the Modify Contact Information option or by uploading the info.txt file.

C. MAIN MENU

Main Menu
- Technician Level Access
_ Fine Consistency Adjustment
_ Performance
_ Modify Settings
_ Utilities
_ Errors and Statistics

The Main Menu screen provides access to all the readings and settings on the IntelliTec2™ control. To access the Main Menu, use one of the keypad sequences from Section 2.1. The example above shows the options available when entering the Manager, Technician or Factory keypad sequence. The Associate will only see the Fine Consistency Adjustment option.

D. FINE CONSISTENCY ADJUSTMENT

The Fine Consistency Adjustment screen has no effect on machine operation.

2.4 PERFORMANCE SCREENS

A. PERFORMANCE (1 OF 2)

Performance (1 of 2)	
Cylinder	Right
Consistency	000.00
Cylinder Temp	-000.0°F
Motor Amps	00.000A
Input Voltage	000.0V

The Performance screens display the current status of the machine. These screens are available to the Manager, Technician, and Factory levels. Press the right arrow to go to the second screen.

Cylinder

The performance information displayed is for the selected cylinder. To change cylinders press the SEL button.

Consistency

Disregard this value. Product consistency is regulated by the torque switch (See Section 2.8)

Cylinder Temperature

This is the current suction line temperature of the selected cylinder.

Motor Amps *

This is the motor amps of the selected cylinder. Note that the Motor Amps are not used to determine product consistency.

Input Voltage *

This is the voltage of the selected cylinder.

* Only shown when the drive motor is running.

B. PERFORMANCE (2 OF 2)

Performance (2 of 2)	
Cylinder	Right
Ambient Temp	-000.0°F
Storage Temp	-000.0°F
Number of Cycles	000
Error Status	No Error

The Performance screens display the current status of the machine. This screen shows the current ambient temperature, storage temperature, and number of cycles since the Push to Freeze button was pressed or the spigot was pulled. Press the left arrow to go back to the first screen.

2.5 SETTINGS SCREENS

A. MODIFY OPERATING SETTINGS

Modify Operating Settings
Reset Serve Amount
_ Basic Settings
_ Advanced Settings
_ Storage Settings
_ User Preferences
_ Time and Date
_ Factory Settings

This menu provides access to view and change the different operating settings on the machine. The Manager, Technician, and Factory levels have access to these screens.

B. BASIC SETTINGS

Basic Settings	
Cylinder	Right
_ CutOut Consist Offset	000
_ CutIn Consist Offset	000
_ Cycles In Serve Mode	000
_ CutIn Refrig Temp	00.0°F
_ CutOut Refrig Temp	00.0°F

This menu contains settings for the CutIn and CutOut, cycles in serve mode and auger cycle times. This screen is available to the Technician and Factory levels.

Cylinder can be changed by pressing the SEL button.

CutOut Consistency Offset has no effect on machine operation.

CutIn Consistency Offset has no effect on machine operation.

Cycles In Serve Mode is a count of the number of freezing cycles.

CutIn Refrig Temp is the suction line temperature in the cylinder when a freezing cycle will start during Refrigerate Mode. Decreasing this value lowers product temperature.

CutOut Refrig Temp is the suction line temperature in the cylinder when a freezing cycle will stop during Refrigerate Mode. Decreasing this value lowers product temperature.

C. ADVANCED SETTINGS

The Advanced Settings options have no effect on machine operation.

E. STORAGE SETTINGS (1 OF 2)

Storage Settings (1 of 2)	
_ Storage Refrigeration	Active
_ Storage CutIn	-00.0°F
_ Storage CutOut	-00.0°F
_ Storage Degree Offset	00°F
_ Storage Off Time	00 min
_ Storage On Time	0000 sec

This Storage Settings menu contains storage refrigeration parameters and is available to the Technician and Factory level. Press the right arrow to go to the second screen.

Storage Refrigeration can be set to Active or Suspend. Active is the normal setting. Suspend is used only for troubleshooting and setting an expansion valve. Never set storage refrigeration to Suspend during normal operation.

Storage CutIn has no effect on machine operation.

Storage CutOut has no effect on machine operation.

The **Storage Degree Offset** value is added to the storage temperature reading to determine if storage refrigeration starts with a freezing cycle. This setting is used in conjunction with the Storage Off Time and Storage On Time during an error.

The **Storage Off Time** setting determines the time between storage refrigeration cycles during a sensor failure.

The **Storage On Time** setting determines the length of a storage refrigeration cycle during a sensor failure.

F. STORAGE SETTINGS (2 OF 2)

This Storage Settings options have no effect on machine operation.

G. USER PREFERENCES

User Preferences	
_ Language	English
_ Temp Units	Fahrenheit(°F)
_ Service Contact Information	
_ Contact Information USB Update	

The User Preferences menu contains language options, temperature units, and service contact information. The screen is available to the Manager, Technician, and Factory levels.

The **Language** setting changes the language displayed. English is the only language currently available.

The **Temperature Units** setting changes the units displayed to Fahrenheit or Celsius.

The **Service Contact Information** option is used to change the service contact details including service company name and number and machine serial number.

The **Contact Information USB Update** option is used for uploading the info.txt file. The info.txt file is available from Stoelting White Glove Service and contains the service company name and telephone number. Select this option after connecting a USB drive to the port on the machine.

H. TIME AND DATE

Time and Date	
Time	00:00:00 AM
Date	00/00/00
Daylight Savings	Off
Clock Type	12 HR
Date Format	
_ Modify Time and Date	

The Time and Date menu shows the time and date settings. The Manager, Technician, and Factory levels can change the time and date by using the Modify Time and Date option.

I. FACTORY SETTINGS (1 OF 6)

Factory Settings (1 of 6)	
Cylinder	Right
_ Pre Stir	00 sec
_ Post Stir	00 sec
_ Off Time	0000 sec
_ Consistency Sensing	Switch

The Factory Settings screen 1 of 6 contains timer settings. The screen is available only to the Factory level.

The **Pre Stir** setting is the amount of time the machine will perform a consistency check before a freezing cycle begins. During the pre stir the drive motor will run and the machine will monitor the torque switch.

The **Post Stir** setting is the amount of time the drive motor will operate after a freezing cycle ends. The post stir ensures product does not freeze to the cylinder.

The **Off Time** setting is the standby time. It is the period between the end of the Post Stir and start of the Pre Stir (without opening the spigot).

Consistency Sensing has no effect on machine operation.

J. FACTORY SETTINGS (2 OF 6) THROUGH (6 OF 6)

The remaining factory settings screens do not affect machine operation and should not be changed.

2.6 UTILITIES SCREENS

```
Utilities (1 of 2)

_ Adjust LCD Contrast
_ Touchpad Lockup
_ Export Machine Stats
_ Clean Options
Next Utilities Menu
```

```
Utilities (2 of 2)
_ Testing and Manual Operation
_ Unit Calibration
_ Clear Log Data
_ Restore Factory Defaults
_ Reset Unit Configuration
```

The Utilities menu gives access to various settings and operations in the control. The Utilities menu is available to the Manager, Technician, and Factory levels. The Manager level will only have access to the first screen. The Technician and Factory levels have access to both screens.

NOTE

Entering the Utilities (2 of 2) screen automatically shuts off the freezing cylinders (refrigeration and drive motors).

A. ADJUST LCD CONTRAST

```
Adjust LCD Contrast

0123456789
ABCDEFGHIJKLMN OPQRSTUVWXYZ

Press ▲ ▼ to change
```

The Adjust LCD Contrast screen adjusts the contrast between the background lighting and the text on the screen.

B. TOUCHPAD LOCKUP

```
Touchpad Lockup

Touchpad Status:          Unlocked

Do you want to lock keys

_ No    Unlock Touchpad
_ Yes   Lock Touchpad
```

The Touchpad Lockup is used to lock and unlock the keypad for self service locations.

C. EXPORT MACHINE STATS

```
Export Machine Stats

This will export statistics
data to stats.txt file
Please insert USB flash memory
Are you sure you want to do that

_ No
_ Yes
```

The Export Machine Stats screen allows you to export all the data and statistics stored in the control. Connect a USB flash drive (1 MB minimum) to the port on the side of the machine and select the yes option.

D. CLEAN OPTIONS

```
Clean Options

Clean History Log
Clean Warning
Clean Lockout
```

The Clean Options Menu gives access to the Clean History Log and Clean Lockout options.

The **Clean History Log** screen shows the date, time and duration of the last 32 clean cycles.

```
Clean History Log (32 of 32)
Cylinder                      Right

Clean Log ID 0:                00/00/00
                               00:00:00

Clean Total Time                000 min
```

The **Clean Warning** and **Clean Lockout** screens are used to enable the clean warning mode or the clean lockout mode. When one of the modes is enabled and the machine is not cleaned within a specified period, the machine will either display a warning (for warning mode) or remain in sleep mode and not go into serve mode (for lockout mode).

```

Clean Warning

Clean Warning Enabled
This option will
require cylinder cleaning
Are you sure you want to do that
_ No - Cancel Clean Warning
_ Yes - Enable Clean Warning
  
```

```

Clean Lockout

Clean Lockout           Disabled
This option will
enforce cylinder cleaning
Are you sure you want to do that
_ No - Cancel Clean Lockout
_ Yes - Enable Clean Lockout
  
```

F. TESTING AND MANUAL OPERATION

The Testing and Manual Operation menu provides access for individual components to be energized to assist with troubleshooting. There are also test monitoring screens that provide details of the machine status during testing. Any energized component will deenergize after leaving the Testing and Manual Operations menu.

```

Testing and Manual Operation
Select below for testing

_ Left Output Control
_ Right Output Control
_ Left / Right Monitoring
  
```

Selecting Left or Right Output Control goes to a screen that allows motors, solenoids, or the compressor to be individually activated. Activate by moving the cursor to the desired component and pressing the SET button.

```

Testing and Manual Ops,      Left
_ Drive Motor                Off
_ Fan Motor                  Off
_ Liquid Solenoid           Off
_ Compressor                 Off
_ Refer Solenoid            Off
_ Aux Solenoid              Off
_ Pump Motor                 Off
  
```

Selecting Left/Right Monitoring goes to screens that show current statistics of the selected cylinder.

The Test Monitoring screens can be used for immediate feedback when troubleshooting. For example the spigot switch can be tested by opening the spigot and observing if the status text changes from "Closed" to "Open".

```

Test Monitoring (1 of 3)
Cylinder                      Right
CRC Errors Dis/IO              0/6791
Motor Voltage                  0.0 V
Motor Current                  0.000
I/V Phase Angle                0.0°
Frequency                      0.0 Hz
Consistency                    0.0
  
```

```

Test Monitoring (2 of 3)
Cylinder                      Right
CRC Errors Dis/IO              0/12
Ambient Temp                   +00.0°F
Cylinder Temp                  +00.0°F
Storage Temp                   +00.0°F
Liquid Level                   OK
  
```

```

Test Monitoring (3 of 3)
Cylinder                      Right
CRC Errors Dis/IO              0/12

Spigot                        Closed
Door                          Closed
Hi Pressure                    No
Torque Switch Input           Off
  
```

G. UNIT CALIBRATION

The Unit Calibration screens have no effect on machine operation.

H. MOTOR CALIBRATION

The Motor Calibration screen has no effect on machine operation.

H. CLEAR LOG DATA

```
Clear Log Data

This will clear the error log
and the statistics.
Are you sure
you want to do that
_ No
_ Yes
```

The Clear Log Data screen will clear all the errors and statistics in memory.

I. RESTORE FACTORY DEFAULTS

```
Restore Factory Defaults

This will reset all machine
settins to the original
factory configurations. Are
you sure you want to do that
_ No
_ Yes
```

The Restore Factory Defaults screen is used to restore the control to the original factory configuration.

J. RESTORE UNIT CONFIGURATION

```
Reset Unit Configuration

This will reset the unit type
and motor types.
Are you sure you want to do that
_ No
_ Yes
```

The Restore Unit Configuration screen allows you to change the motor type default. The E122 unit configuration is 0, and the F122 unit configuration is 1.

2.7 ERRORS & STATISTICS SCREENS

The Errors & Statistics menu gives the Technician and Factory levels access to machine statistics and error history.

```
Errors and Statistics

_ Machine Statistics
_ Error History
```

A. MACHINE STATISTICS (1 OF 10)

```
Machine Statistics (1 of 10)
Cylinder                               Right
Time in Serve Mode                     0000 hr
    Last 24hrs                          0000 min
    Last 7days                          0000 hr
Time in Off Mode                        0000 hr
    Last 24hrs                          0000 min
    Last 7days                          0000 hr
```

The Machine Statistics screen 1 of 10 shows the time in serve mode and time in sleep mode. The screen shows a running total, the total for the previous day, and the total for the previous week for both statistics.

B. MACHINE STATISTICS (2 OF 10)

```
Machine Statistics (2 of 10)
Cylinder                               Right

Total Low Mix Time                     0000 hr
    Last 24hrs                          0000 min
    Last 7days                          0000 hr
```

The Machine Statistics screen 2 of 10 shows the low mix running time. This is the total time, including serve mode and sleep mode, that the freezing cylinder was operating with a low mix error. The screen shows a running total, the total for the previous day, and the total for the previous week.

C. MACHINE STATISTICS (3 OF 10)

Machine Statistics (3 of 10)	
Cylinder	Right
Last Clean Cycle	00/00/00 00:00:00 AM
Last Clean Time	0000 min

The Machine Statistics screen 3 of 10 provides the time and date that the freezing cylinder was last cleaned. This value is recorded when the Clean button is pressed on the touchpad. The screen also shows how long the most recent clean mode lasted.

D. MACHINE STATISTICS (4 OF 10)

Machine Statistics (4 of 10)	
Cylinder	Right
Spigot Open Total	0000 min
Last 24hrs	0000 min
Last 7days	0000 min
Spigot Total Cycles	0000
Average Spigot Open	0000 sec

The Machine Statistics screen 4 of 10 shows the total time that the spigot has been open during serve mode. The screen shows a running total, the total for the previous day, and the total for the previous week. The screen also shows the total times that the spigot has been opened.

E. MACHINE STATISTICS (5 OF 10)

Machine Statistics (5 of 10)	
Cylinder	Right
Estimated Serve Amount	0000 gal
Last Reset Amount	00/00/00 00:00:00 AM

The Machine Statistics screen 5 of 10 gives the estimated serve amount of the freezing cylinder based on the time the spigot is open during serve mode. The estimation is also calculated for the previous day and the previous week. The screen gives an option to reset the serve amount and shows when the last reset was done.

F. MACHINE STATISTICS (6 OF 10)

Machine Statistics (6 of 10)	
Cylinder	Right
Compressor Run Time	0000 hr
Compressor Cycles	0000
Last Compressor Reset	00/00/00 00:00:00
_ Reset Compressor Time	

The Machine Statistics screen 6 of 10 shows the total run time for the compressor and counts the total cycles. There is an option to reset the timer and the screen shows when the last reset was done. Only reset the compressor time if the compressor is changed.

G. MACHINE STATISTICS (7 OF 10)

Machine Statistics (7 of 10)	
Cylinder	Right
Motor Run Time	0000 hr
Motor Cycles	0000
Last Motor Reset	00/00/00 00:00:00 AM
_ Reset Motor Time	

The Machine Statistics screen 7 of 10 shows the total run time for the drive motor and counts the total cycles. There is an option to reset the timer and the screen shows when the last reset was done. Only reset the motor time if the drive motor is changed.

H. MACHINE STATISTICS (8 OF 10)

Machine Statistics (8 of 10)	
Cylinder	Right
Pump Run Time	0000 hr
Pump Cycles	0000
Last Pump Reset	00/00/00 00:00:00 AM
_ Reset Pump Time	

The Machine Statistics screen 8 of 10 does not apply to this machine.

I. MACHINE STATISTICS (9 OF 10)

Machine Statistics (9 of 10)	
Cylinder	Right
Current Hose Usage	0000 hr
Hose Service Limit	100 hr
Last Hose Reposition	00/00/00
	00:00:00 AM
_ Reset Hose Service Time	

The Machine Statistics screen 9 of 10 does not apply to this machine.

J. MACHINE STATISTICS (10 OF 10)

Machine Statistics (10 of 10)	
Last Unit Power Up	00/00/00
	00:00:00
Avg Power KWH/Day	0 Watts

The Machine Statistics screen 10 of 10 shows when the machine was last powered on. The screen also gives an average power consumption per day.

K. ERROR HISTORY

Error History	25 of 25
Type	Cylinder Sensor
Date	00/00/00 00:00:00 AM
Cylinder	Right
_ Status At Time of Error	
_ Help	

The Error History screen shows the last error that occurred. The screen shows the type of error, the time and date and the cylinder that had the error. Up to 25 errors are stored. Press the up or down arrow to scroll through the errors. Select the Status at Time of Error option to view data for the time the error occurred. The Help option explains the error and provides quick troubleshooting tips.

L. STATUS AT TIME OF ERROR

Status at Time of Error		
Operating Mode		Off
Mix Levels		Full Level
Consistency		000.00
Input V/A/P		000.0V 00 00
Outputs Status		0 0 0 0 0 0 0
Inputs Status		0 0 0 0 0 0
Amb/Cyl Temp		-000.0°F -000.0°F

The Status at Time of Error screen gives data for the time the error occurred.

2.8 PRODUCT CONSISTENCY ADJUSTMENT

The Consistency Adjustment Screw increases or decreases product consistency by changing the amount of torque needed to complete a refrigeration cycle. Turn the knob clockwise to increase consistency.

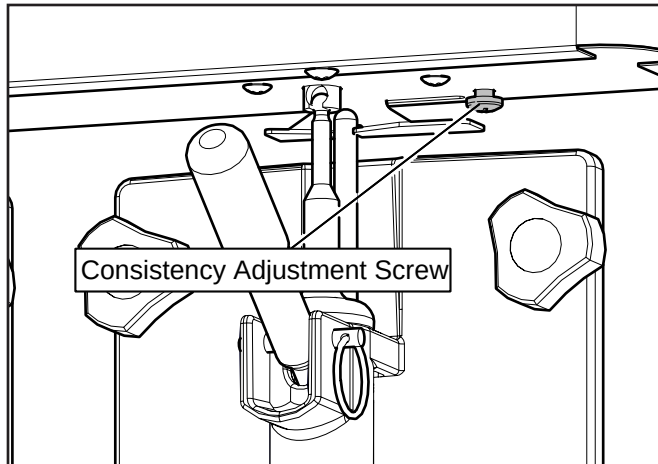

TENSION SPRINGS

An optional spring is included with the machine and is for use with **shake mixes only**. It is located behind the header panel. To change springs, remove the header panel, unhook the original spring from the torque switch assembly and hook the new spring into place.

E122 - The standard spring is green. The optional spring is yellow. The yellow spring is thicker.

F122 - The standard spring is yellow. The optional spring is red. The red spring is thicker.

2.9 DRIVE BELT TENSION ADJUSTMENT

To check belt tension, follow the steps below:

- A. Remove the side panels and back panel.
- B. Use a Burroughs Belt Tension Gauge to check the drive belt tension. The belt tension should be 50-55 lbs.
- C. If an adjustment is necessary, loosen the four motor plate retaining nuts, adjust belt tension bolt then retighten the four nuts.
- D. Using a straightedge, check that the drive motor pulley is aligned with the speed reducer pulley. Align the pulley if necessary.

NOTE

Belt life will be increased if new drive belts are tightened after two or three weeks of operation.

2.10 PREVENTIVE MAINTENANCE

Stoelting recommends that a maintenance schedule be followed to keep the machine clean and operating properly.

A. DAILY

1. The exterior should be kept clean at all times to preserve the luster of the stainless steel. A mild alkaline cleaner is recommended. Use a soft cloth or sponge to apply the cleaner.
2. Make sure nothing is blocking airflow around the machine.

B. WEEKLY

1. Check o-rings and rear seal for excessive wear and replace if necessary.
2. Remove the drip tray by gently lifting up to disengage from the support and pulling out. Clean behind the drip tray and front of the machine.

C. QUARTERLY

The air-cooled condenser is a copper tube and aluminum fin type. Condensing is totally dependent upon airflow. A plugged condenser filter, condenser, or restrictions in the louvered panel will restrict airflow. This will lower the capacity of the system and damage the compressor.

The condenser must be kept clean of dirt and grease. The E122 must have a minimum of 4" (10.2 cm) of ventilation at the back. The F122 must have a minimum of 6" (15.2 cm) of ventilation on both sides of the unit for free flow of air.

The condenser and condenser filter require periodic cleaning. To clean, refer to the following procedures.

F122 Air Cooled Condenser Cleaning

- A. Disconnect power to the machine
- B. Remove the Phillips head screws from the right side panel, and remove the panel.
- C. To remove a condenser filter, grasp the top and pull off. Visually inspect the filters for dirt. If a filter is dirty, shake or brush excess dirt off the filter and wash it in warm, soapy water. Once it is clean, rinse it thoroughly in warm, clear water and shake dry, taking care not to damage the filter in any way.

E122 Air Cooled Condenser Cleaning

- A. Unscrew the knob located on the underside of the machine.
- B. Remove the filter bracket and remove the filter.
- C. Visually inspect the condenser filter for dirt.
- D. If the filter is dirty, vacuum or brush clean, rinse with clean water and allow to dry before replacing on the machine.

D. SEMI-ANNUALLY

1. Disconnect the machine from the power source.
2. Check drive belt for proper tension.
3. Lubricate condenser fan motor with S.A.E. 20 weight oil. Three to six drops is required.
4. Sanitize the autofill system (if applicable) following the steps below:

AUTOFILL SANITIZING

- A. If necessary, disassemble, clean and sanitize the machine.

NOTE

If the machine does not require cleaning and sanitizing, press the Pump On/Off button to turn off the pump. Then dispense enough product so that the mix level in the hopper is below the long probe. If the mix level is above the long probe, the solenoid will not activate and the pump will not operate.

- B. Prepare Stera-Sheen Green Label Sanitizer or equivalent according to manufacturer's instructions to provide a 100ppm strength solution. Mix the sanitizer in quantities of no less than 2 gallons of 90° to 110°F (32° to 43°C) water. Any sanitizer must be used only in accordance with the manufacturer's instructions.
- C. Cut an adapter from an empty bag of syrup. Connect the adapter to the Bag-In-Box (BIB) connector of the syrup line. Put the BIB connector into the bucket of sanitizer.

NOTE

If you do not have an empty bag of syrup, remove the plug from the top of the BIB connector. Do not lose the plug; it is needed for proper operation of the BIB.

- D. Make sure the display screen shows that the main power is on. Hold the hopper cover over a bucket and press the Pump On/Off button. The solenoid will activate and the brix pump will pump sanitizer into the bucket.

NOTE

The solenoid will only activate when there is not any liquid touching the longer mix probe in the hopper.

- E. After all the sanitizer has run through the pump, press the Pump On/Off button to turn off the pump.
- F. Disconnect the bag adapter from the BIB connector (or reinsert the plug into the connector). Connect the BIB connector to the syrup BIB.
- G. Hold the hopper cover over a bucket and press the Pump On/Off button. This will flush the sanitizer out of the pump and tubing. Once the sanitizer is flushed out, press the Pump On/Off button.

- H. The pump is now ready to operate. Place the hopper cover on the hopper.

2.11 EXTENDED STORAGE

Refer to the following steps for storage of the machine over any long period of shutdown time:

- A. Follow the cleaning and sanitizing procedures for the machine and follow the semi-annual instructions to sanitize the autofill system.
- B. Press the Main Power On/Off button so that power to the machine is off.
- C. Disconnect (unplug) from the electrical supply source.
- D. Thoroughly clean all parts that come in contact with mix. Rinse in clean water and dry parts. Do not sanitize.

NOTE

Do not leave cleaning solution in the hopper or in the freezing cylinder during the shutdown period.

- E. Remove, disassemble and clean the front door, mix inlet regulator and auger parts.

SECTION 3 REFRIGERATION & WIRING DIAGRAMS

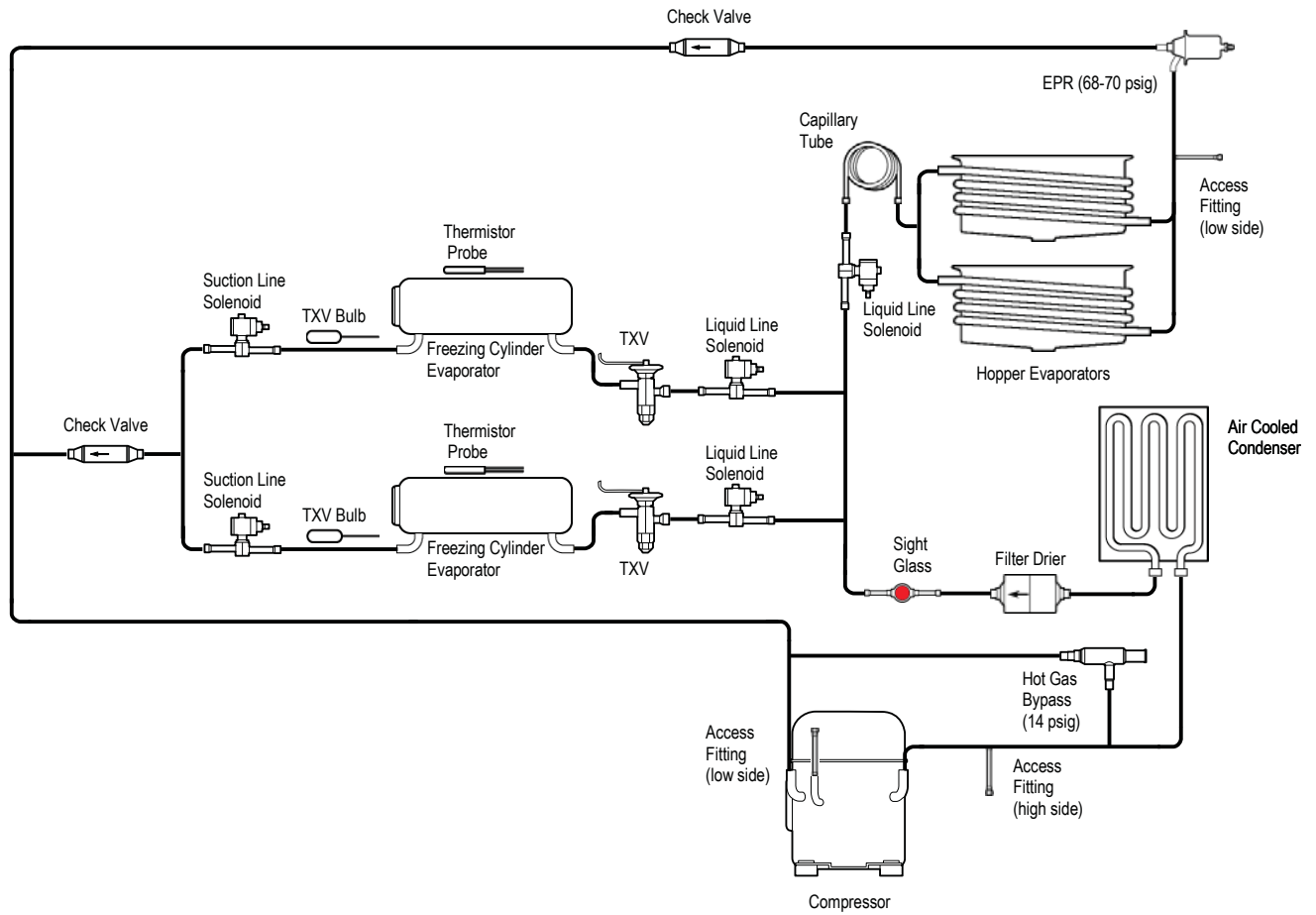

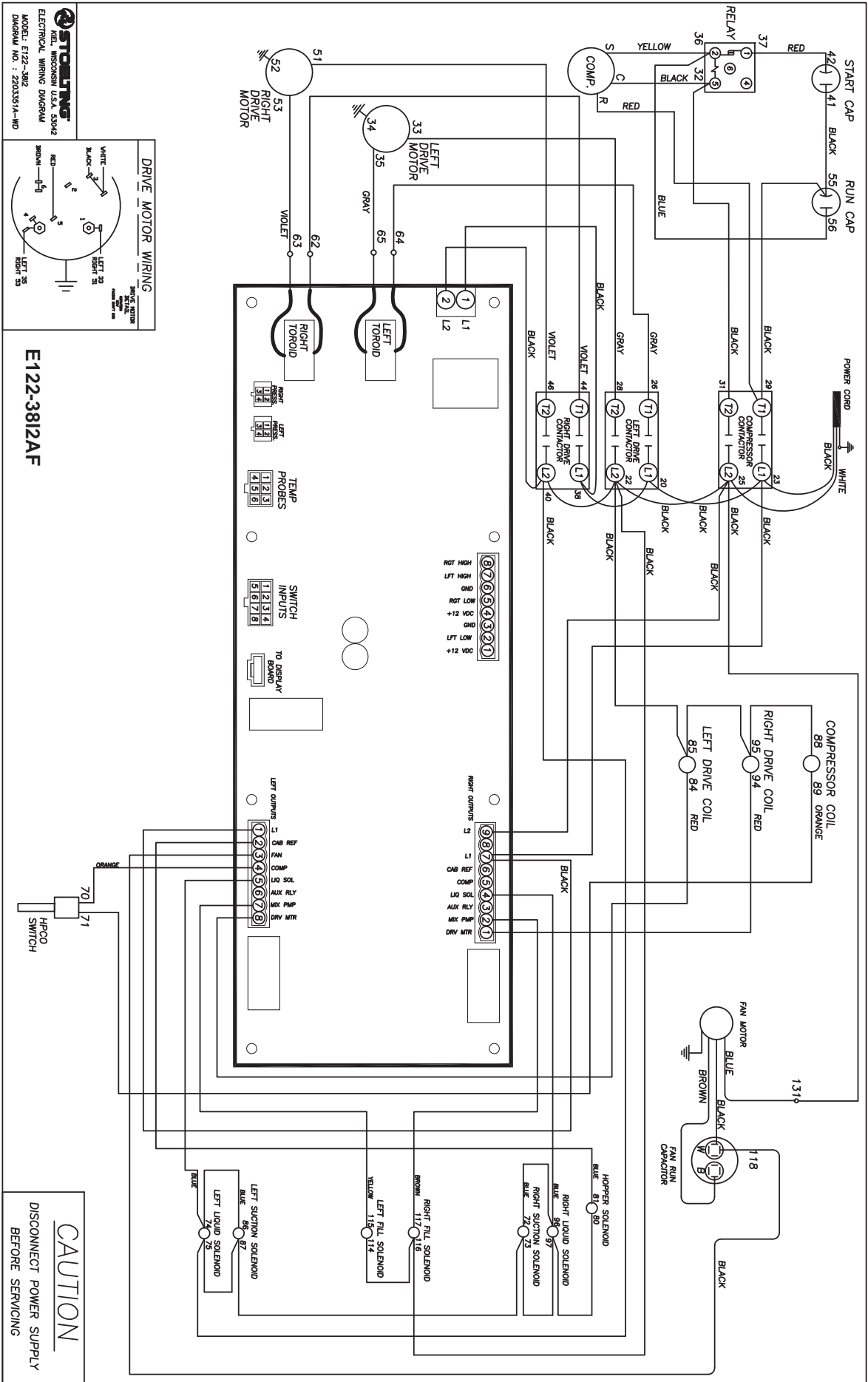

STORLING
 KEEL, WISCONSIN U.S.A. 53042
 ELECTRICAL WIRING DIAGRAM
 MODEL: E122-3812AF
 DIAGRAM NO.: 22033181B-WD

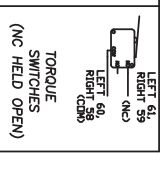
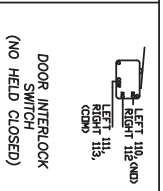
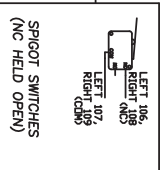

E122-3812AF

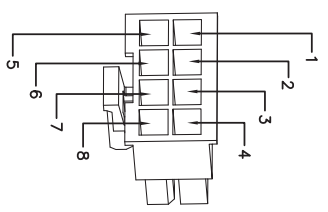
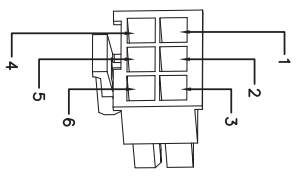
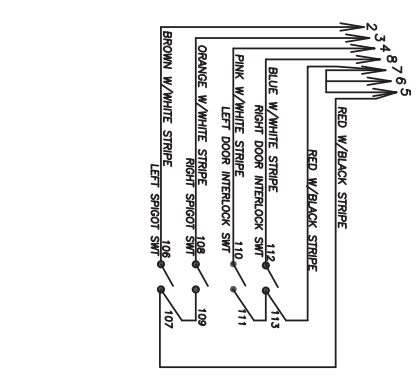
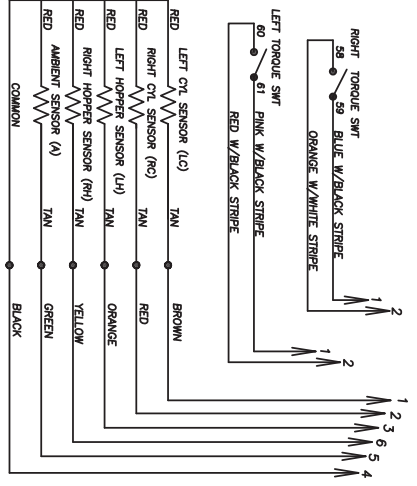

CAUTION
 DISCONNECT POWER SUPPLY
 BEFORE SERVICING

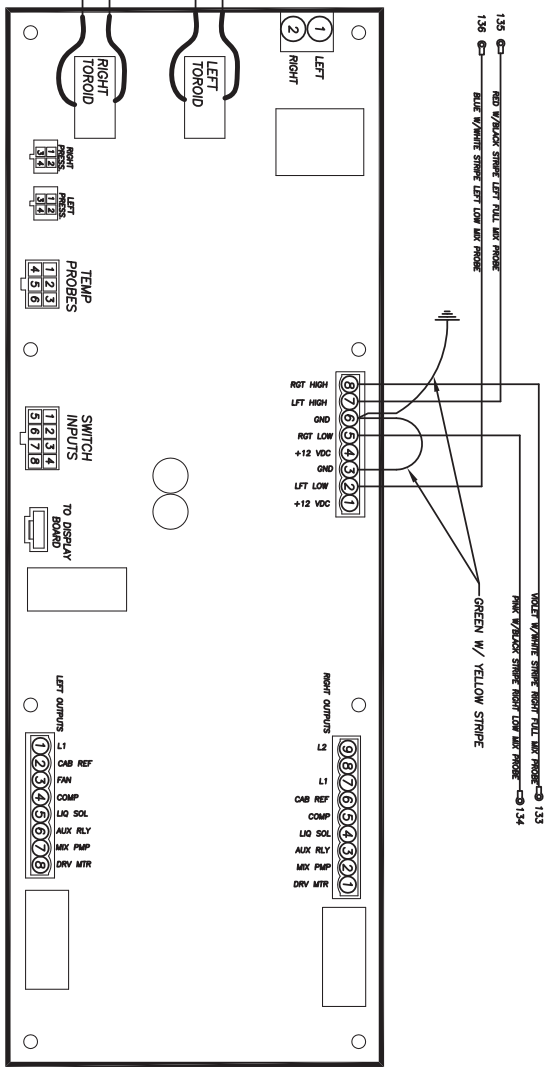
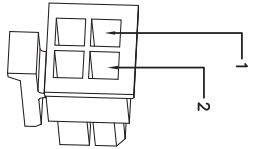

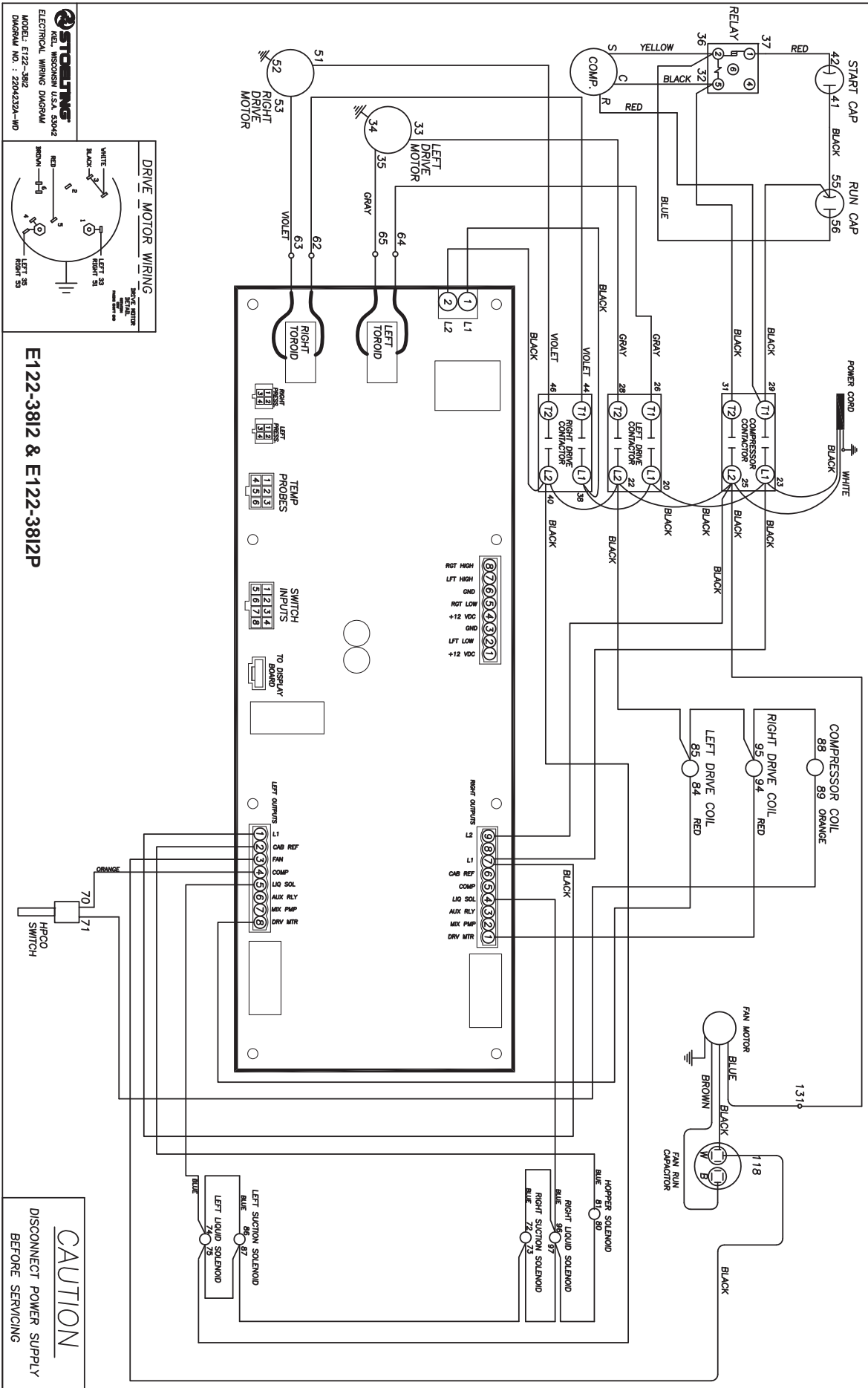

E122-3812 & E122-3812P

STORLING
 KEEL, WISCONSIN U.S.A. 53042
 ELECTRICAL WIRING DIAGRAM
 MODEL: E122-3812
 DIAGRAM NO.: 2204232B-WD

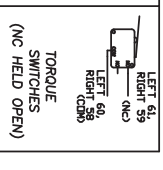
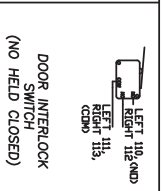
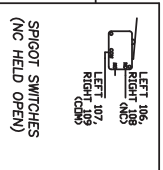

E122-3812 & E122-3812P

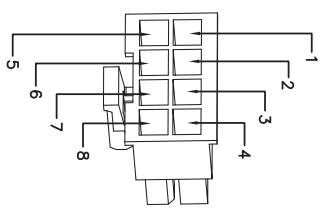
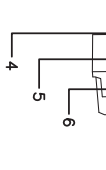
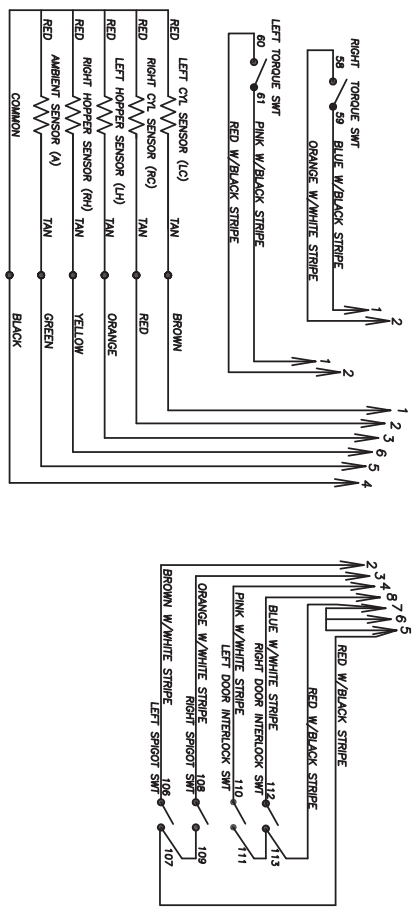

CAUTION
 DISCONNECT POWER SUPPLY
 BEFORE SERVICING

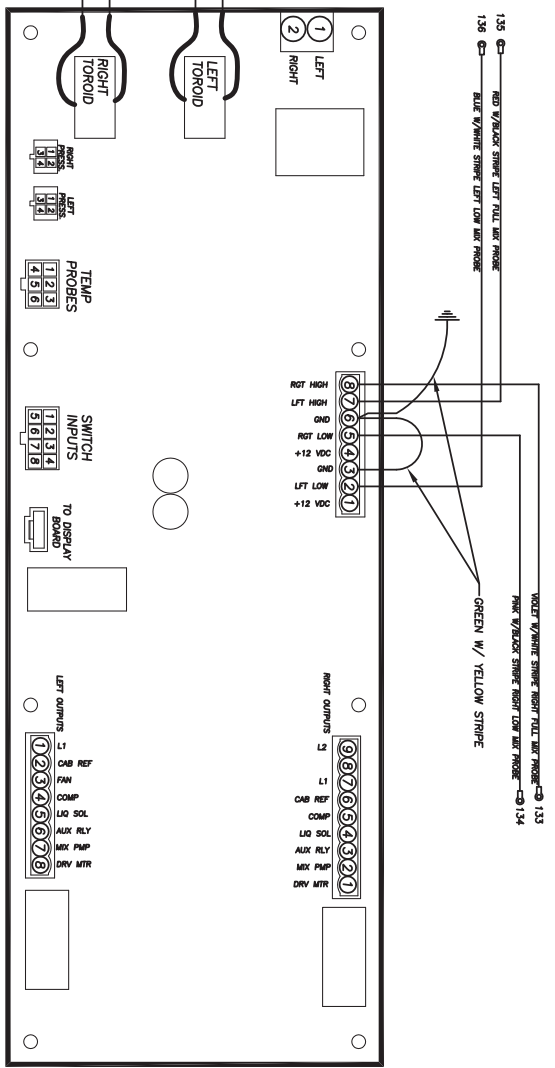

F122-3812-AF & F122-3812AF

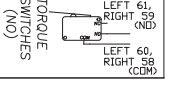
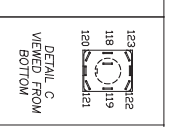
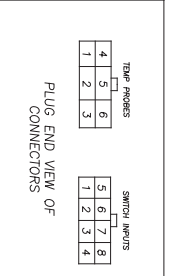
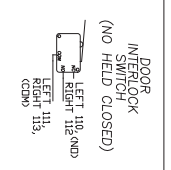
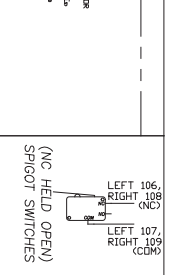
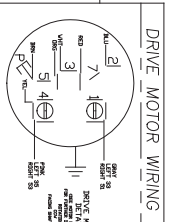
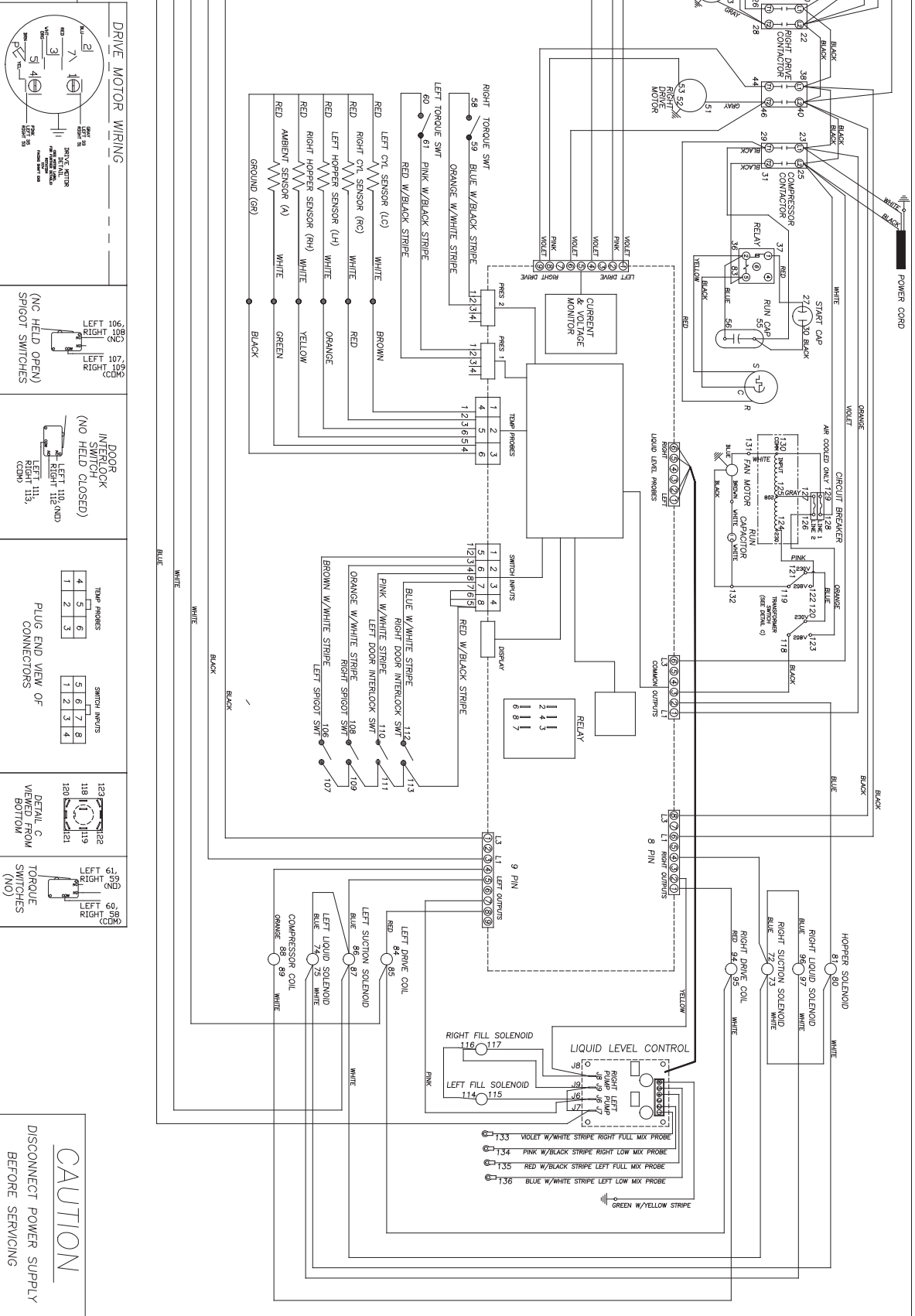

CAUTION
 DISCONNECT POWER SUPPLY BEFORE SERVICING

F122X-30212

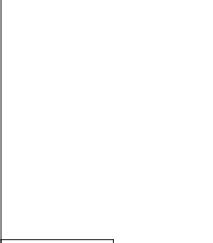
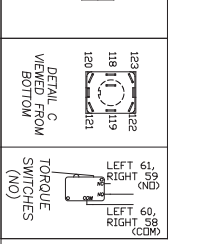
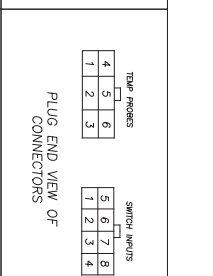
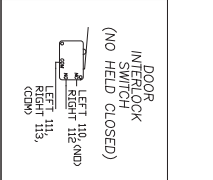
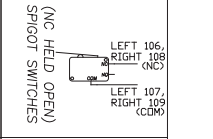
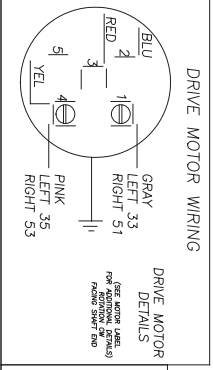
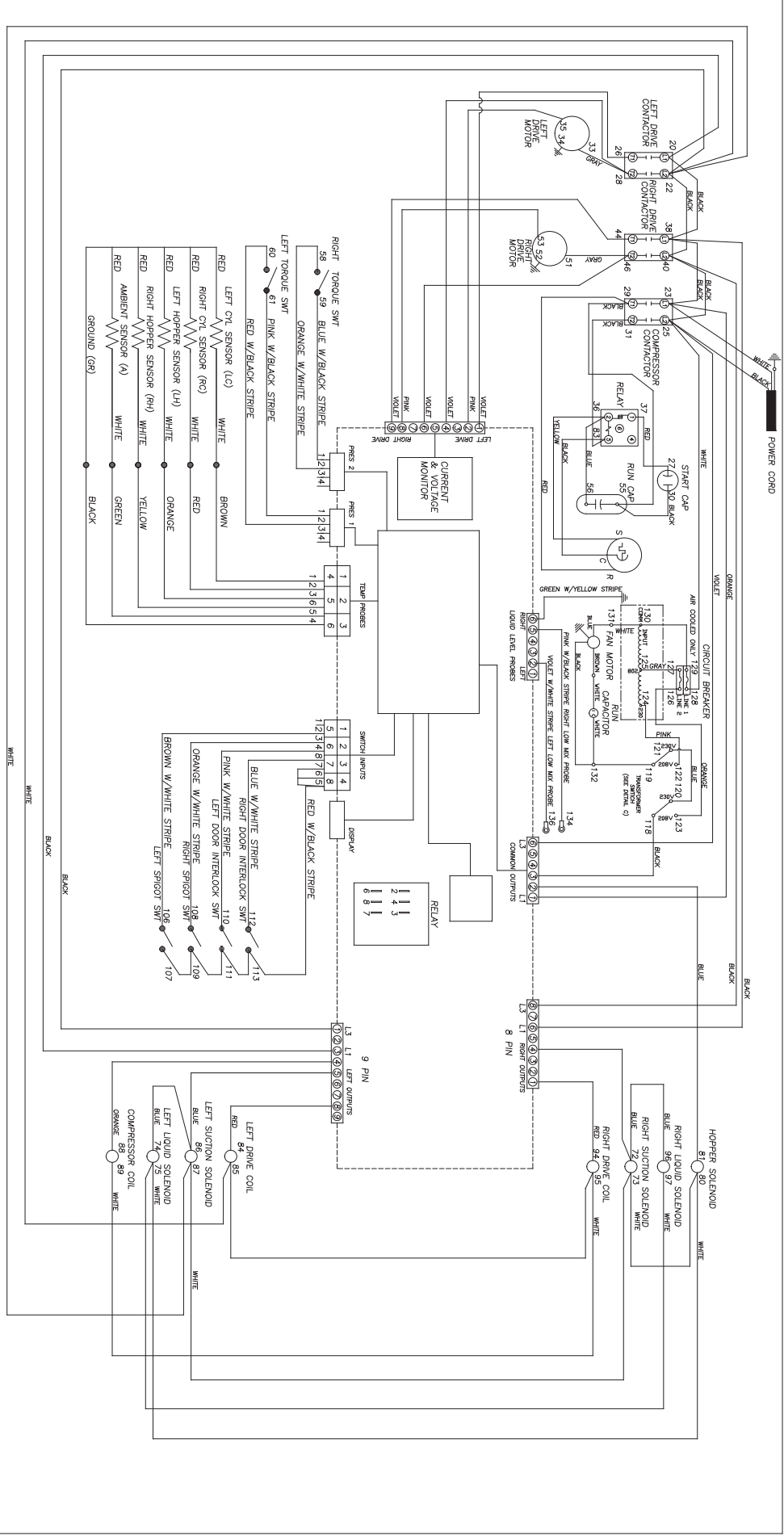

CAUTION
 DISCONNECT POWER SUPPLY BEFORE SERVICING

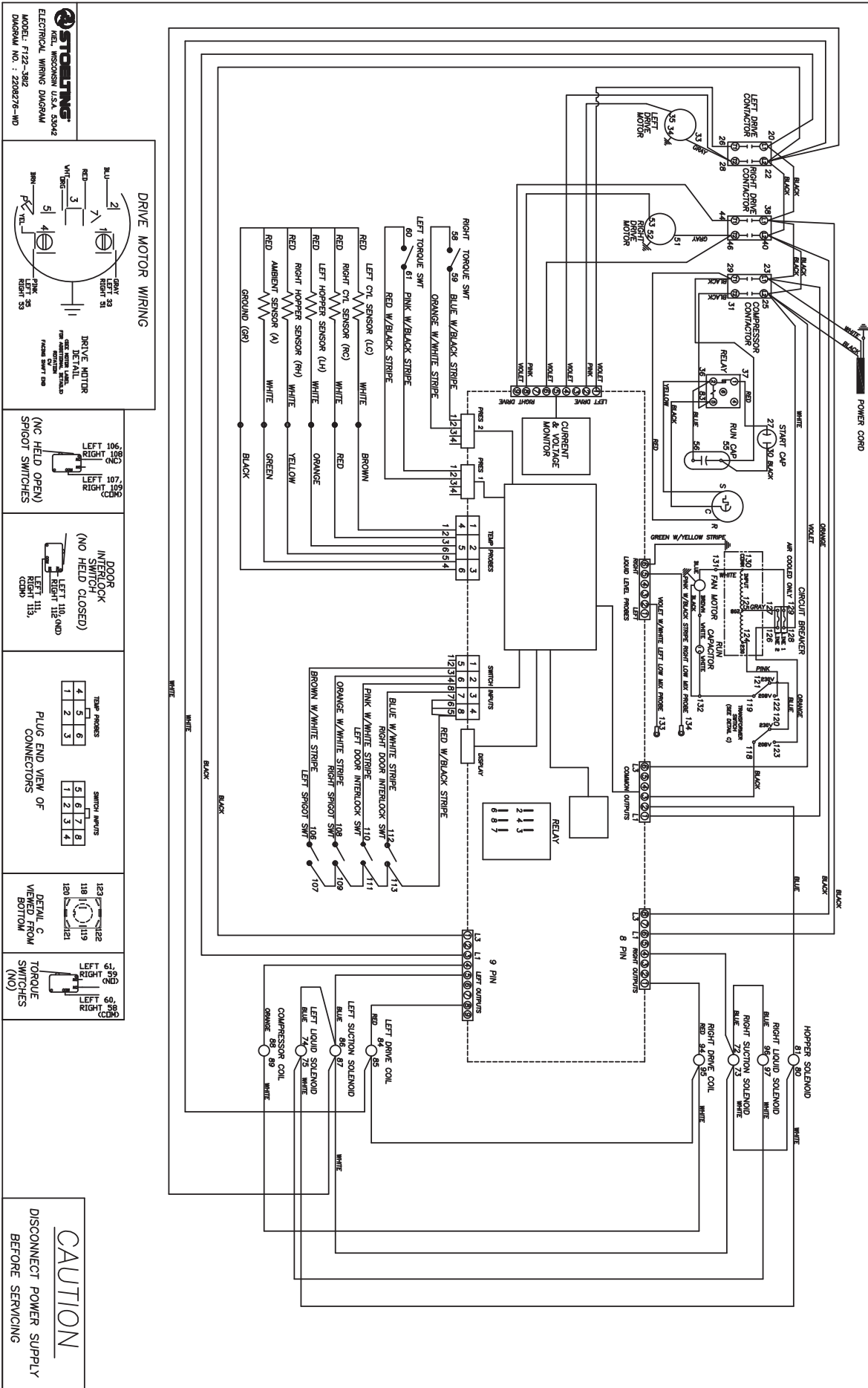

SECTION 4 REPLACEMENT PARTS

4.1 DECALS AND LUBRICATION

Part	Description	Quantity	
		E122	F122
C-1000-26C	Decal - Made In USA	1	1
208135	Brush - 4" X 8" X 16" (Barrel)	1	1
208380	Brush - 1/4" X 3" X 14"	1	1
208401	Brush - 1" X 3" X 10"	1	1
232091	Cap - Protective (Gray) - #490716 Leg		1
236054	Card - Cleaning Instructions - Brix Pump (Auto Fill)	1	1
236065	Card - Cleaning Instruction - E122 & F122	1	1
324065	Decal - Water Inlet		1
324105	Decal - Caution Electrical Shock	4	3
324106	Decal - Caution Electrical Wiring Materials	1	1
324107	Decal - Caution Hazardous Moving Parts	2	2
324141	Decal - Caution Rotating Blades	1	1
324208	Decal - Attention Refrigerant Leak Check	2	2
324509	Decal - Cleaning Instructions	1	1
324548	Decal - Adequate Ventilation 6"	2	2
324594	Decal - Attention Heat Sensitive	2	2
324686	Decal - Danger Automatic Start		2
324804	Decal - Domed Stoelting Swirl (Header Panel)	1	1
324888	Decal - Fan Motor Reset		1
324901	Decal - Transformer Switch		1
324909	Decal - USB Port	1	1
324921	Decal - Arctic Quake		1
324922	Decal - Assembly Check	1	
324938	Decal - 4" Ventilation	1	
325023	Decal - Stoelting (Black) (Large)	1	1
325024	Decal - Stoelting (Black) (Small)	1	1
325032	Decal - White Glove Service	1	1
396245	Gasket - Freezer Base		1
490716	Leg		4
490749	Leg - Front	2	
490750	Leg - Rear (w/Suction Cup)	2	
508053	Lubricant - Total Blend (50 Packets)	1	1
513667	Manual - Operators	1	1
1183955	O-Ring Kit	-	
2183636	Spacer - Leg	4	
2203790	Sensor Probe Kit	-	-

4.2 AUGER SHAFT AND FACEPLATE PARTS

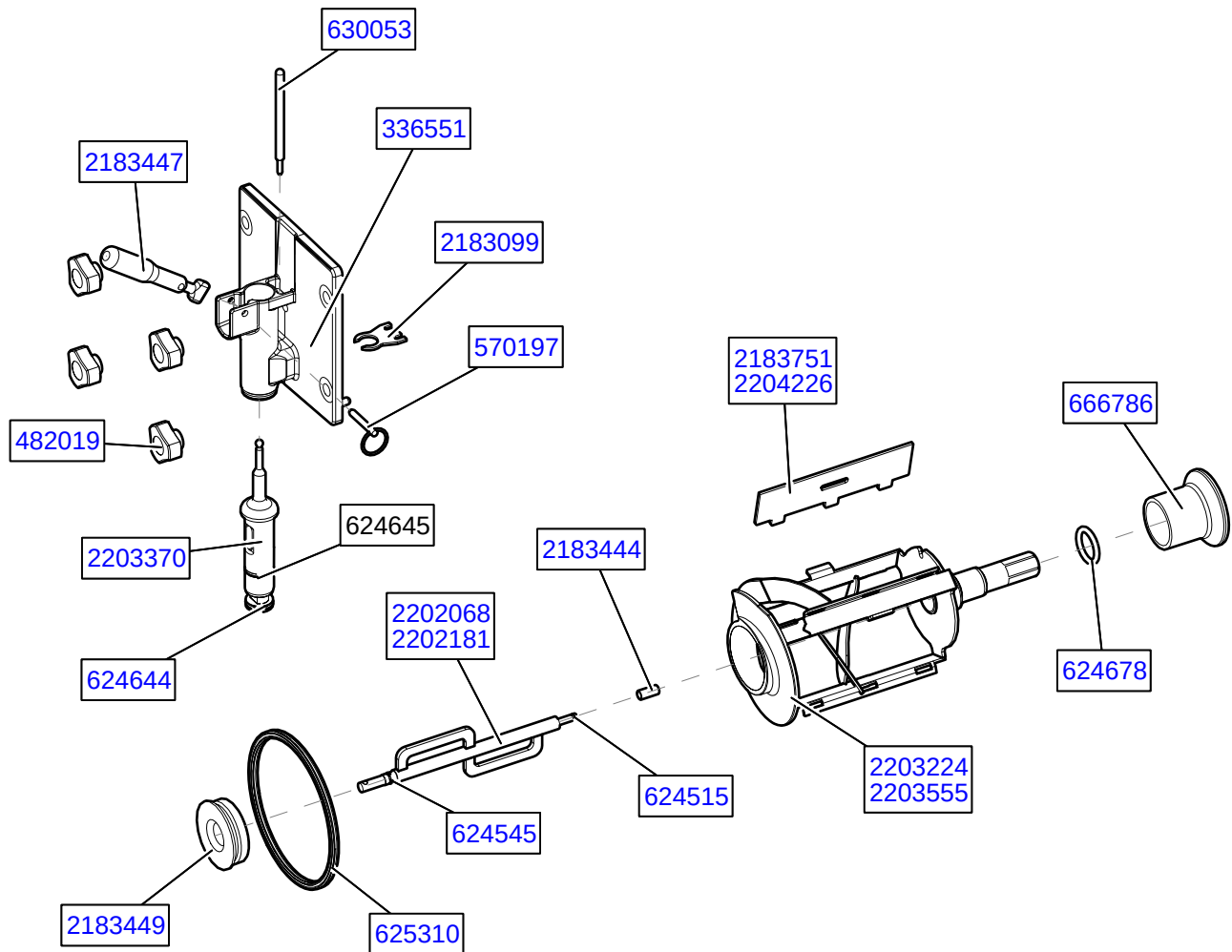

Part	Description	Quantity	
		E122	F122
336551	Door - Front	2	2
482019	Knob - Front Door (Black)	8	8
570197	Pin - Cotterless Clevis (Front Door)	2	2
624515-5	O-Ring - Stator Bar Rear (5 Pack)	2	2
624545-5	O-Ring - Stator Bar Front (5 Pack)	2	2
624644-5	O-Ring - Spigot Body (Bottom) (5 Pack)	2	2
624645-5	O-Ring - Spigot Body (Top) (5 Pack)	2	2
624678-5	O-Ring - Rear Seal - Black (5 Pack)	2	2
625310	Quad-Ring - Front Door - Black	2	2
630053	Rod - Torque Actuator	2	2
666786	Seal - Rear Auger - Black	2	2
2183099	Breaker Bar - Spigot Body	2	2
2183444	Bushing - Stator Support (Rear)	2	2
2183447	Handle Only - Spigot	2	2
2183449	Bushing - Front Auger Support	2	2
2183751	Blade - Scraper		2
2202068	Stator Bar		2
2202181	Stator Bar	2	
2203224	Auger Shaft		2
2203370	Spigot Body	2	2
2203555	Auger Shaft	2	
2204226	Blade - Scraper	2	

4.3 HOPPER PARTS

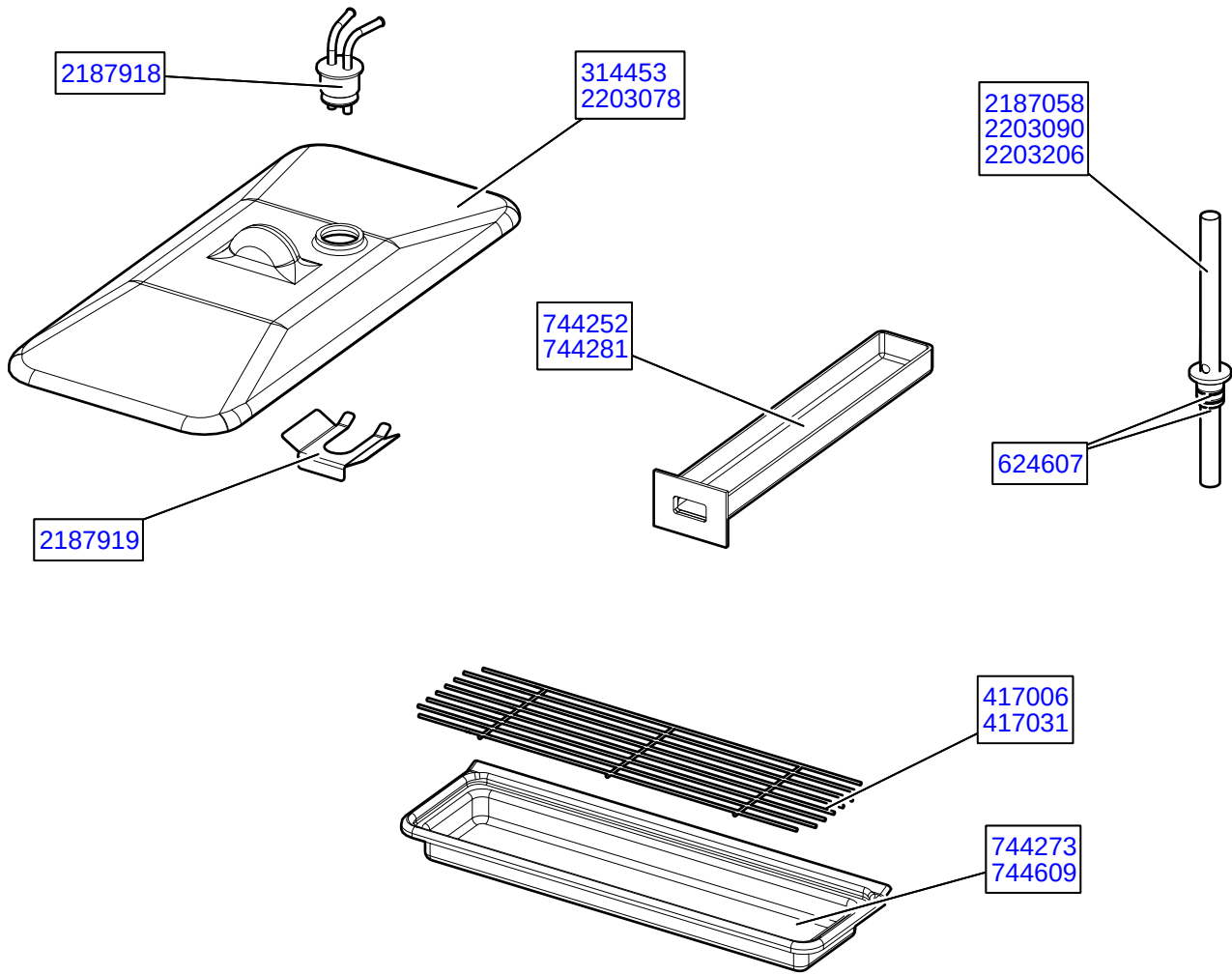

Part	Description	Quantity	
		E122	F122
314453	Cover - Hopper	2	2
417006	Grid - Drip Tray (Vinyl Coated Metal)		1
417031	Grid - Drip Tray	1	
624607-5	O-Ring - Mix Inlet (5 Pack)	4	4
744252	Tray - Drain		1
744273	Tray - Drip		1
744281	Tray - Drain (Front)	1	
744609	Tray - Drip	1	
2187058	Mix Inlet Regulator	2	
2187918	Mix Inlet Adapter (Auto Fill)	2	2
2187919	Clip - Retaining (Mix Inlet Adapter) (Auto Fill)	2	2
2203090	Mix Inlet Regulator		2
2203078	Cover - Hopper (Auto Fill)	2	2
2203206	Mix Inlet Regulator (Auto Fill)		2

4.4 MOTOR COMPONENTS

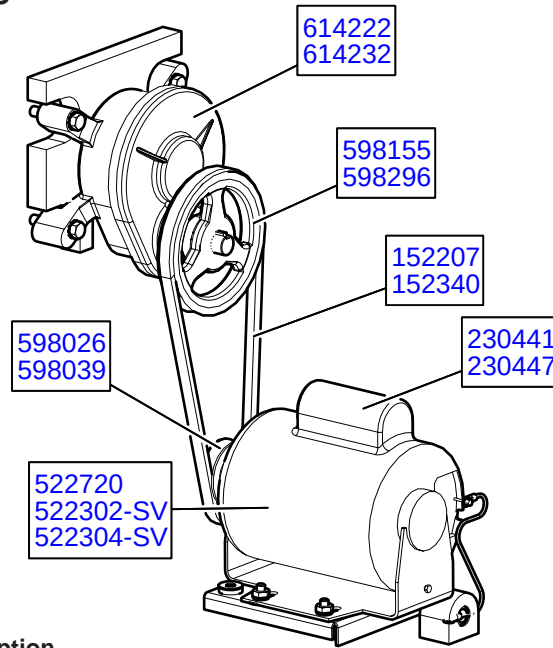

Part	Description	Quantity	
		E122	F122
152207	Belt - Gripnotch (AX29) (Each)	2	
152340	Belt - Gripnotch (AX41) (Each)		2
230441	Capacitor Start (#522235 Motor)		2
230447	Capacitor (#522720 Drive Motor)	2	
230685	Capacitor - Start (#522302-SV Motor)		2
230687	Capacitor - Run (#522302-SV Motor)		2
522720	Motor - Drive - 1/3 HP (60 Hz)	2	
522302-SV	Motor - Drive w/Mounting Base - 1PH - 60Hz		2
522304-SV	Motor - Drive w/Mounting Base - 1PH - 50Hz		2
598026	Pulley - Drive Motor	2	
598039	Pulley - Drive Motor		2
598155	Pulley - Speed Reducer	2	
598296	Pulley - Speed Reducer		2
614222	Speed Reducer		2
614232	Speed Reducer	2	

4.5 SPIGOT ASSEMBLY

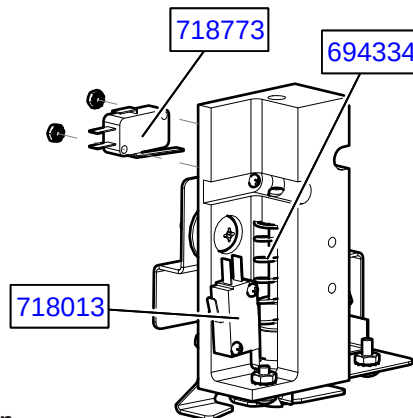

Part	Description	Quantity	
		E122	F122
694334	Spring - Compression (Spigot Switch) (2.25")	2	2
694336	Spring - Compression (Spigot Switch) (2.75")	2	
695706	Spring - Consistency Adjustment (Green)	2	
695707	Spring - Consistency Adjustment (Yellow)	2	2
695714	Spring - Consistency Adjustment (Red)	2	2
718013	Switch - Roller (Spigot)	2	2
718773	Switch - Limit (Torque Consistency)	2	2

4.6 PANELS & SCREWS

Part	Description	Quantity	
		E122	F122
644734	Screw - Panel (Sides & Rear)	-	-
647653	Screw - Panel (Header)		-
647886	Screw - Drip Tray Support Bracket	-	
647899	Screw - Panel (Front)		-
649114	Screw - Panel (Rear Air Plenum)		-
2202679	Panel - Header	1	
2202681	Drip Tray Support Bracket	1	
2202884	Panel - Front		1
2202885	Panel - L.H. Side		1
2202886	Panel - R.H. Side		1
2202887	Panel - Rear		1
2202896	Panel - Header		1
2203051	Panel - Drip Tray		1
2203584	Panel - L.H. Side	1	
2203589	Panel - Front	1	
2203590	Panel - R.H. Side	1	
2202776-1	Panel - Rear	1	
2206167	Plenum Assembly (L.H. Side)		1
2206173	Panel - Rear Air Plenum	1	

4.7 KITS & MISCELLANEOUS

Part	Description	Quantity	
		E122	F122
396245	Gasket - Freezer Base		1
513667	Manual - Owner's	1	1
1183955	O-Ring Kit	-	
2203790	Sensor Probe Kit	-	-

4.8 ELECTRICAL COMPONENTS

Part	Description	Quantity	
		E122	F122
202245	Circuit Breaker (Air-Cooled Only)		1
229148	Cable - IntelliTec2 (Control Board to Display Board)	1	1
229158	USB Cable Extension	1	1
230632	Capacitor - Start (Compressor)	1	
230649	Capacitor - Start (#282050 Compressor)	1	
230654	Capacitor (Fan Motor)		2
230665	Capacitor - Fan Motor	2	
230666	Capacitor - Run (Compressor)	1	
231079	Capacitor - Start (#282032 Compressor)		1
231084	Capacitor - Run (#282032 & #282050 Compressors)		1
232452	Plug - USB	1	1
292353	Connector - 9 Pin Phoenix (#521513 Board)		1
292354	Connector - 8 Pin Phoenix (#521514 Board)		1
292355	Connector - 9 Pin Phoenix (#521514 Board)		1
292356	Connector - 6 Pin Phoenix (#521514 Board)		1
292357	Connector - 6 Pin Phoenix (Low Mix) (#521513 Board)		1
292358	Connector - 6 Pin Molex (Thermistor) (#521513 Board)		1
292359	Connector - 8 Pin Molex (Switch Input) (#521513 Board)		1
295017	Contact (45CG20AG) (Compressor & Drive)	3	3
332563	Board - Display Module	1	1
430119	Cord - Power (60 Hz)		1
430172	Cord - Power	1	
430608	Cord - Power (50 Hz) (Cord Only - No Plug)		1
521511	Board - Program - IntelliTec2	1	
521512	Board - Control - Mix Level (Auto Fill)		1
521513	Board - Program / Power (IntelliTec2)		1
521514	Board - Relay (IntelliTec2)		1
521516	Board - Program / Relay (IntelliTec2)		1
610038	Diode (IntelliTec2)		1
618157	Relay - Start (#282032 & #282050 Compressors)		1
618363	Relay - Compressor (60 Hz)	1	
694200	Spring - Door Interlock	2	2
718539	Switch - Toggle (Transformer Voltage Selector) (208/230V) (Air-Cooled Only)		1
719111	Switch - Limit (Door Interlock)	1	1
719127-SV	Switch - Membrane Strip (Touchpad & Ribbon)	1	1
719128-SV	Switch - Membrane Strip (Touchpad & Ribbon)	1	
743654	Transformer - Booster (Air-Cooled Only)		1
2177301	Probe Assembly - Hopper (5")	2	2
2177302	Probe Assembly - Hopper (3.25")	2	2
2183006	Probe Assembly - Hopper Liquid Level (Long) (Non Autofill Units))	1	

4.8 ELECTRICAL COMPONENTS (CONTINUED)

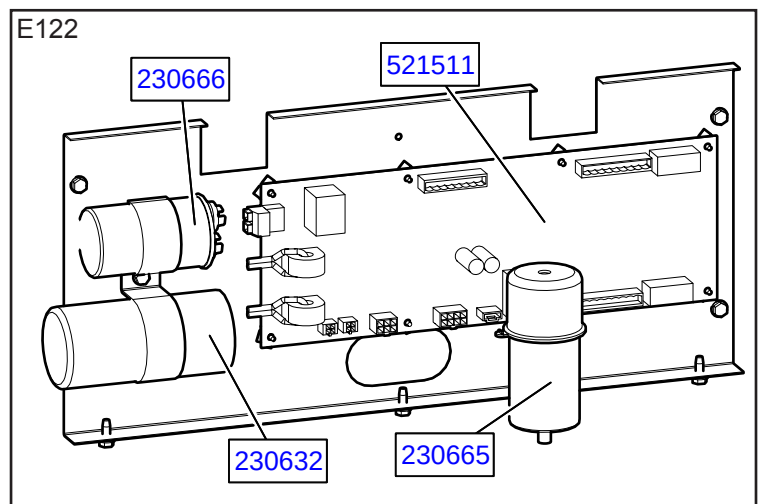
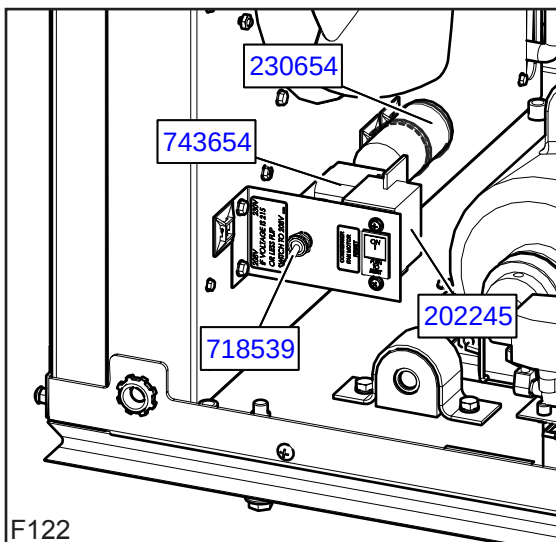
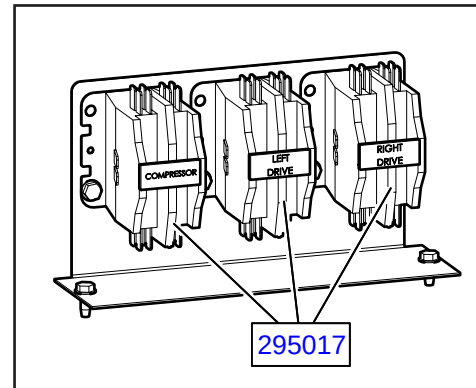
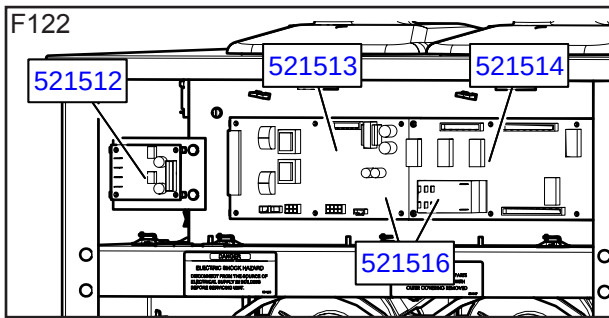
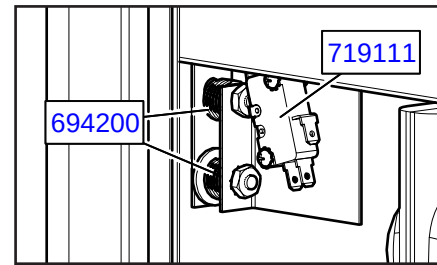
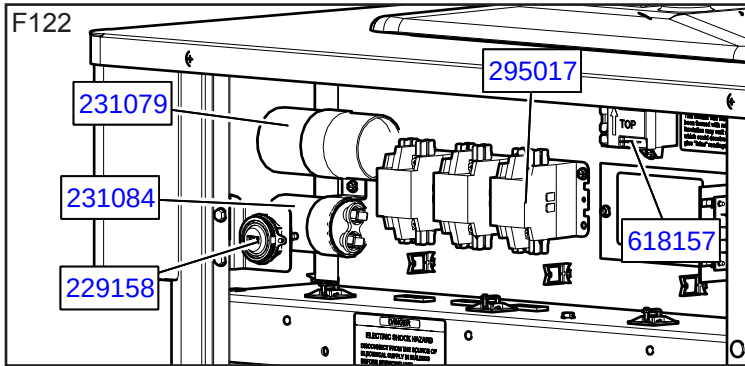
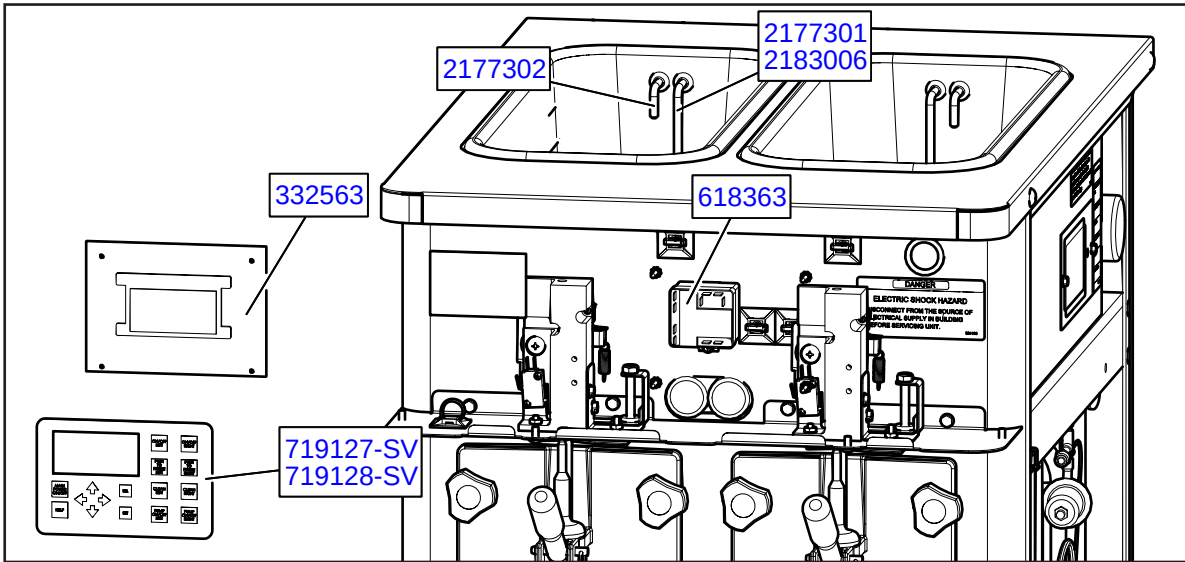

4.9 REFRIGERATION

Part	Description	Quantity	
		E122	F122
231107	Cap Tube Only		1
231107-SV	Cap Tube & Drier Assembly	1	
282032-SV	Compressor - Copeland 1 PH - 60 Hz - R404A (No Capacitors)		1
282050	Compressor - 1 PH (50 Hz) (No Capacitors)		1
282094	Compressor - Copeland 1 PH (No Capacitors)	1	
284000	Condenser - Air Cooled	1	
284084	Condenser (Air-Cooled)		1
284104	Condenser (Water-Cooled)		1
342006	Drier	1	
342008	Drier		1
357102	Motor - Fan (Air-Cooled Condenser) (Includes Blade & Guard)		1
357105	Fan - Axial (Includes Blade & Grill)	1	
368140	Filter - Air		1
368466	Filter - Condenser	1	
458003	Sight Glass	1	
458009	Sight Glass		1
482004	Knob - Rear Filter Support	1	
718794	Switch - High Pressure Reset	1	
762275	Valve - Magna Check	1	
762277	Valve - Magna Check		1
762455	Valve - Expansion (R404A)		2
762482	Valve - Expansion	2	
762604	Valve - Solenoid (3/8") (Liquid Line)		2
762978	Valve - EPR	1	1
763002	Valve - Solenoid (1/2") (Suction)		2
763012	Valve - Hot Gas Bypass	1	1
763181	Valve - Water		1
763422	Valve - Solenoid (1/4") (Liquid Line)	3	1
763482	Valve Coil - Solenoid (#763422)	3	1
763674	Valve - Solenoid (1/2") (Suction Line)	2	
763674B	Valve Coil - Solenoid (#763674)	2	
2202669	Evaporator Assembly	1	
2202880	Evaporator		1

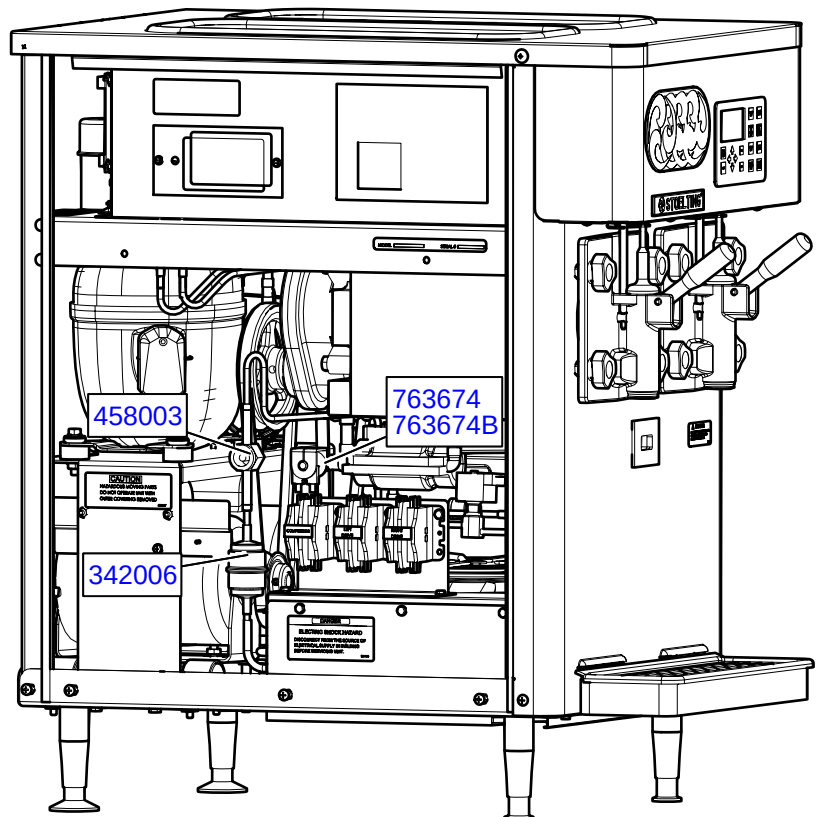
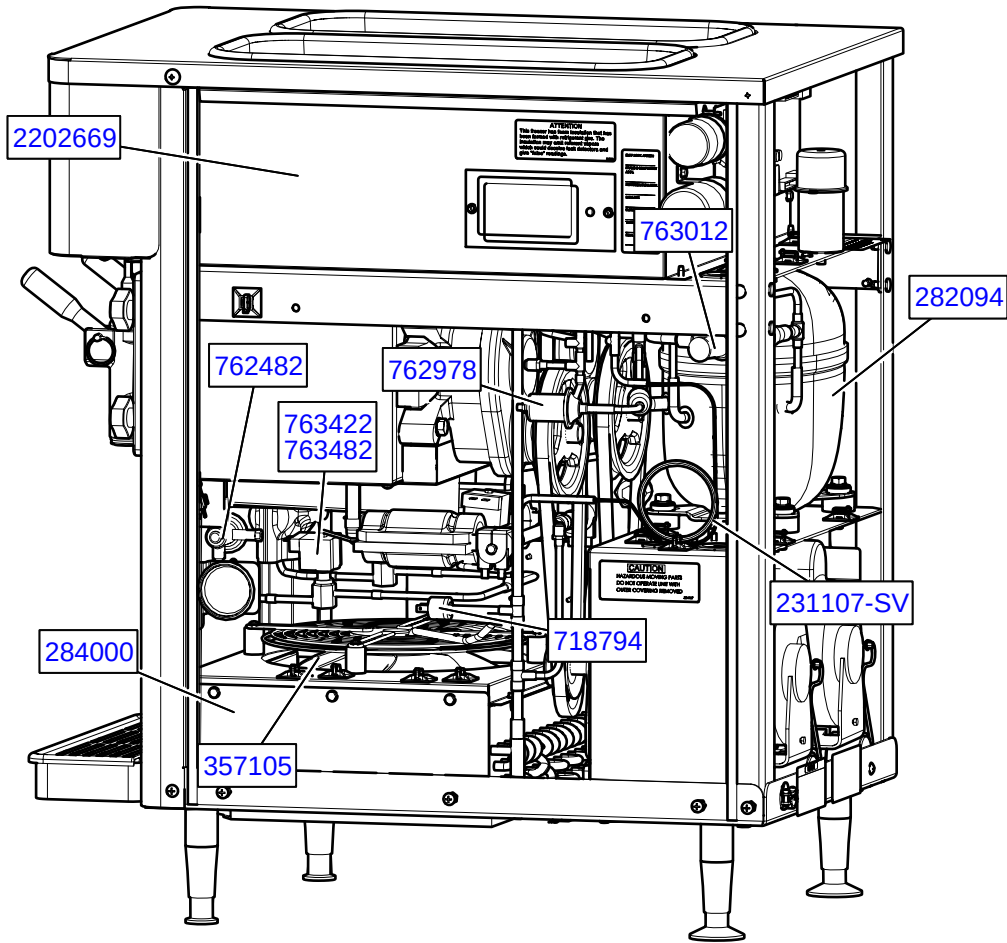

4.10 AUTO FILL PARTS

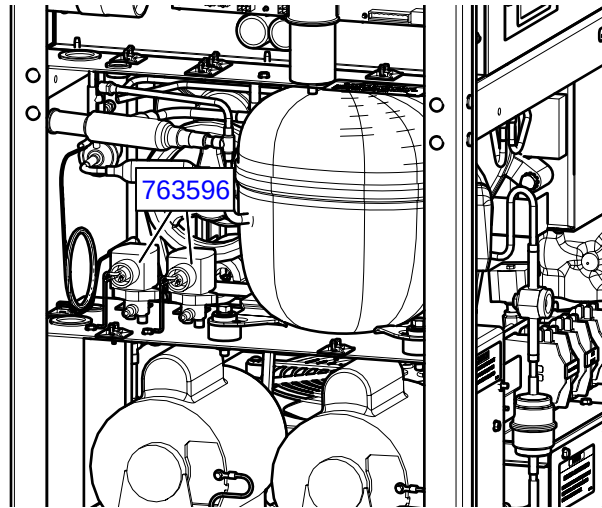

Part	Description	Quantity	
		E122	F122
264096	Clamp - Oetiker (Tubing to Hopper Cover)		18
264235	Clamp - Metal (Tubing to Solenoid)		4
376086	Hose Adapter (1/4" x 3/8")	4	4
756067	Tubing - 1/4" ID - Clear (Mix Inlet to Solenoid) (Per Inch)	192"	120"
756187	Tubing - 1/4" ID - Braided (Syrup Solenoid) (Per Inch)	96"	192"
763596	Valve - Solenoid	2	2