



**Model F231**  
**SERVICE MANUAL**

Manual No. [513659](#)

Rev.2



This manual provides basic information about the machine. Instructions and suggestions are given covering its operation and care.

The illustrations and specifications are not binding in detail. We reserve the right to make changes to the machine without notice, and without incurring any obligation to modify or provide new parts for machines built prior to date of change.

**DO NOT ATTEMPT** to operate the machine until instructions and safety precautions in this manual are read completely and are thoroughly understood. If problems develop or questions arise in connection with installation, operation, or servicing of the machine, contact Stoelting.



[stoeltingfoodservice.com](http://stoeltingfoodservice.com)

Stoelting Foodservice Equipment  
502 Highway 67  
Kiel, WI 53042-1600  
U.S.A.

Main Tel: 800.558.5807  
Fax: 920.894.7029

Customer Service: 888.429.5920  
Fax: 800.545.0662  
Email: [foodservice@stoelting.com](mailto:foodservice@stoelting.com)

© 2014 PW Stoelting, LLC

---

## ***A Few Words About Safety***

### **Safety Information**

**Read and understand the entire manual before operating or maintaining Stoelting equipment.**

This manual provides the operator with information for the safe operation and maintenance of Stoelting equipment. As with any machine, there are hazards associated with their operation. For this reason safety is emphasized throughout the manual. To highlight specific safety information, the following safety definitions are provided to assist the reader.

The purpose of safety symbols is to attract your attention to possible dangers. The safety symbols, and their explanations, deserve your careful attention and understanding. The safety warnings do not by themselves eliminate any danger. The instructions or warnings they give are not substitutes for proper accident prevention measures.

If you need to replace a part, use genuine Stoelting parts with the correct part number or an equivalent part. We strongly recommend that you do not use replacement parts of inferior quality.



### **Safety Alert Symbol:**

**This symbol** Indicates danger, warning or caution. Attention is required in order to avoid serious personal injury. The message that follows the symbol contains important information about safety.

### **Signal Word:**

Signal words are distinctive words used throughout this manual that alert the reader to the existence and relative degree of a hazard.



The signal word "WARNING" indicates a potentially hazardous situation, which, if not avoided, may result in death or serious injury and equipment/property damage.



The signal word "CAUTION" indicates a potentially hazardous situation, which, if not avoided, may result in minor or moderate injury and equipment/property damage.

### **CAUTION**

The signal word "CAUTION" not preceded by the safety alert symbol indicates a potentially hazardous situation, which, if not avoided, may result in equipment/property damage.

### **NOTE (or NOTICE)**

The signal word "NOTICE" indicates information or procedures that relate directly or indirectly to the safety of personnel or equipment/property.

# INTELLITEC2™ FIRMWARE VERSION UPDATE LOG

The list below shows the history of the firmware versions in the IntelliTec2™ control. The information in this manual refers to Version 20.39.

## VERSION 20.52

Released on 8/22/11

- Motor Calibration screen now returns to the current status screen after pressing the left arrow.
- Refer Solenoid text changed to Storage Refrigeration.
- When exporting the error log data the file name is now the serial number of machine.
- Serial Number can now be changed in the Modify Contact Information screen.
- CutIn Offset changed to 20 (was 30)
- Default Offtime changed to 450 (was 300)

## VERSION 20.39

Released on 3/2/11

- Added phase reversal detection for 3 phase machines
- Added Spigot Open Time error Error 21
- Added support for I/O update
- Changed High Torque Error 2 detection to be directly from motor amperage and not from a calculated factor

## VERSION 20.27

Released on 12/28/10

- Added Unit Serial Number to Service Contact Information and Modify Contact Information
- Added Clean Warning to Clean Options

## VERSION 20.15

Released 11/23/10

- Added Enable Control to Basic Settings
- Removed Enable CutOut Temp from Basic Settings
- Changed CutOut Consistency to CutOut Consistency Offset
- Added CutIn Consistency Offset
- Moved Sleep 1 Drive On and Sleep 1 Drive Off to Factory Settings from Advanced Settings
- Moved Stir On and Stir Off to Advanced Settings from Factory Settings
- Added Storage Refrigeration to Storage Settings
- Storage CutIn changed to 37.5°F (was 37°F)
- Moved Pressure Sensing and Liquid Sensing to Factory Settings
- Added Clean Options to Utilities page 1
- Moved Clean Lockout to Clean Options from Utilities page 1
- Added Clean History Log to Clean Options

## **VERSION 17.19**

Released on 9/8/10

*Note: They are few initial machines with 15.19 (8/23/10) where cutout consistency was 70, then pulleys were changed. Two machines with 16.19 had 60 as cutout limit, then some minor internal reset timers were changed and 17.19 released on 9/8/10*

- Consistency Limit changed to 60 (was 110 for 1 phase / 80 for 3 phase)
- Moved Stir On and Stir Off to Factory Settings from Basic Settings
- Enable CutOut Temp and CutOut Temp moved to Basic Settings from Factory Settings
- Sleep 1 Drive Off changed to 600 seconds (was 300 seconds)
- Sleep 2 CutIn changed to 33°F (was 38°F)
- Sleep 2 CutOut changed to 30.5°F (was 30°F)

*(continued on next page)*

## **VERSION 17.19 (CONTINUED)**

- Storage CutOut changed to 32°F (was 31°F)
- Storage Offset changed to 4°F (was 2°F)
- Storage Off Time changed to 13 min (was 2 min)
- Storage On Time changed to 130 sec (was 200 sec)
- Storage Max On changed to 3 min (was 10 min)
- Storage Recovery changed to 4 min (was 1 min)
- Clean Lockout Period moved to Factory Settings from Storage Settings
- Touchpad Lockup moved to Utilities from User Preferences
- Date Format added to Time and Date
- Added second Utilities page
- Changed Utilities page 1 to be accessible to Manager passcode
- Testing and Manual Operation, Restore Factory Defaults, Clear Error Log and Clear Statistics moved to Utilities page 2 from page 1
- Added Product Selection, Export Machine Stats to Utilities page 1
- Removed Clear EEPROM Map from Utilities
- Added Motor Zero Load Calibration, Restore Motor Table Defaults and Reset Unit Configuration to Utilities page 2

# TABLE OF CONTENTS

Section	Description	Page
<b>1</b>	<b>Description and Specifications</b>	
1.1	Description.....	1
1.2	Specifications .....	2
<b>2</b>	<b>Installation Instructions</b>	
2.1	Safety Precautions .....	5
2.2	Shipment and Transit.....	5
2.3	Machine Installation.....	5
2.4	Installing Permanent Wiring.....	5
2.5	Initial Startup of IntelliTec2™ .....	6
<b>3</b>	<b>Initial Set-Up and Operation</b>	
3.1	Operator's Safety Precautions.....	9
3.2	Operating Controls and Indicators.....	9
3.3	Disassembly of Machine Parts .....	10
3.4	Cleaning Disassembled Parts .....	11
3.5	Sanitizing Machine Parts .....	11
3.6	Cleaning the Machine.....	11
3.7	Assembling the Machine .....	12
3.8	Sanitizing .....	12
3.9	Freeze Down and Operation .....	13
3.10	Fine Consistency Adjustment .....	13
3.11	Mix Information .....	14
<b>4</b>	<b>Maintenance and Adjustments</b>	
4.1	Accessing Control Readings and Settings .....	15
4.2	Navigation and Modifying Settings .....	15
4.3	User Interface Screens.....	15
4.4	Performance Screens.....	16
4.5	Settings Screens .....	16
4.6	Utilities Screens.....	18
4.7	Errors & Statistics Screens.....	21
4.8	Updating Firmware .....	23
4.9	Drive Belt Tension Adjustment.....	24
4.10	Condenser Cleaning.....	25
4.11	Preventative Maintenance .....	25
4.12	Extended Storage.....	25

<b>Section</b>	<b>Description</b>	<b>Page</b>
<b>5</b>	<b>Refrigeration System</b>	
5.1	Refrigeration System .....	27
5.2	Refrigerant Recovery and Evacuation.....	27
5.3	Refrigerant Charging .....	28
5.4	Compressor .....	29
5.5	Condenser .....	30
5.6	Valves .....	30
A.	Thermostatic Expansion Valve (TXV) .....	30
B.	Automatic Expansion Valve (AXV).....	31
C.	Check Valve .....	32
D.	High Pressure Cutout.....	32
E.	Hot Gas Bypass .....	32
F.	Evaporator Pressure Regulator (EPR).....	33
G.	Water Valve (Water Cooled Models Only).....	34
5.7	Solenoid.....	34
5.8	Filter Drier.....	36
5.9	Capillary Tube.....	36
<b>6</b>	<b>Electrical and Mechanical Control Systems</b>	
6.1	IntelliTec2™ Control .....	37
6.2	Contactors .....	37
6.3	Drive Motor .....	38
6.4	Capacitors .....	39
6.5	Gearbox.....	39
6.6	Condenser Fan Motor (Air-Cooled Only).....	39
6.7	Spigot Switch.....	40
6.8	Temperature Control Sensor .....	41
<b>7</b>	<b>Troubleshooting</b>	
7.1	Error Codes .....	43
7.2	Troubleshooting .....	44
7.3	Troubleshooting - Machine .....	46
<b>8</b>	<b>Replacement Parts</b>	
8.1	Decals and Lubrication .....	47
8.2	Panels and Screws.....	47
8.3	Auger Shaft and Faceplate Parts .....	48
8.4	Air Plenum Kit.....	49
8.5	Internal Components .....	50
8.6	Spigot Assembly .....	52
8.7	Front .....	52
8.8	Wiring Diagrams .....	53

# SECTION 1 INTRODUCTION

## 1.1 DESCRIPTION

The Stoelting F231 floor machine is gravity fed. The machine is equipped with the IntelliTec2™ control which provides a uniform product. The F231 is designed to operate with almost any type of commercial soft serve or non-dairy mixes available, including: ice milk, ice cream, yogurt, and frozen dietary desserts.

This manual is designed to assist qualified service personnel and operators in the installation, operation and maintenance of the Stoelting F231 gravity machine.



Figure 1-1 Model F231

## 1.2 SPECIFICATIONS

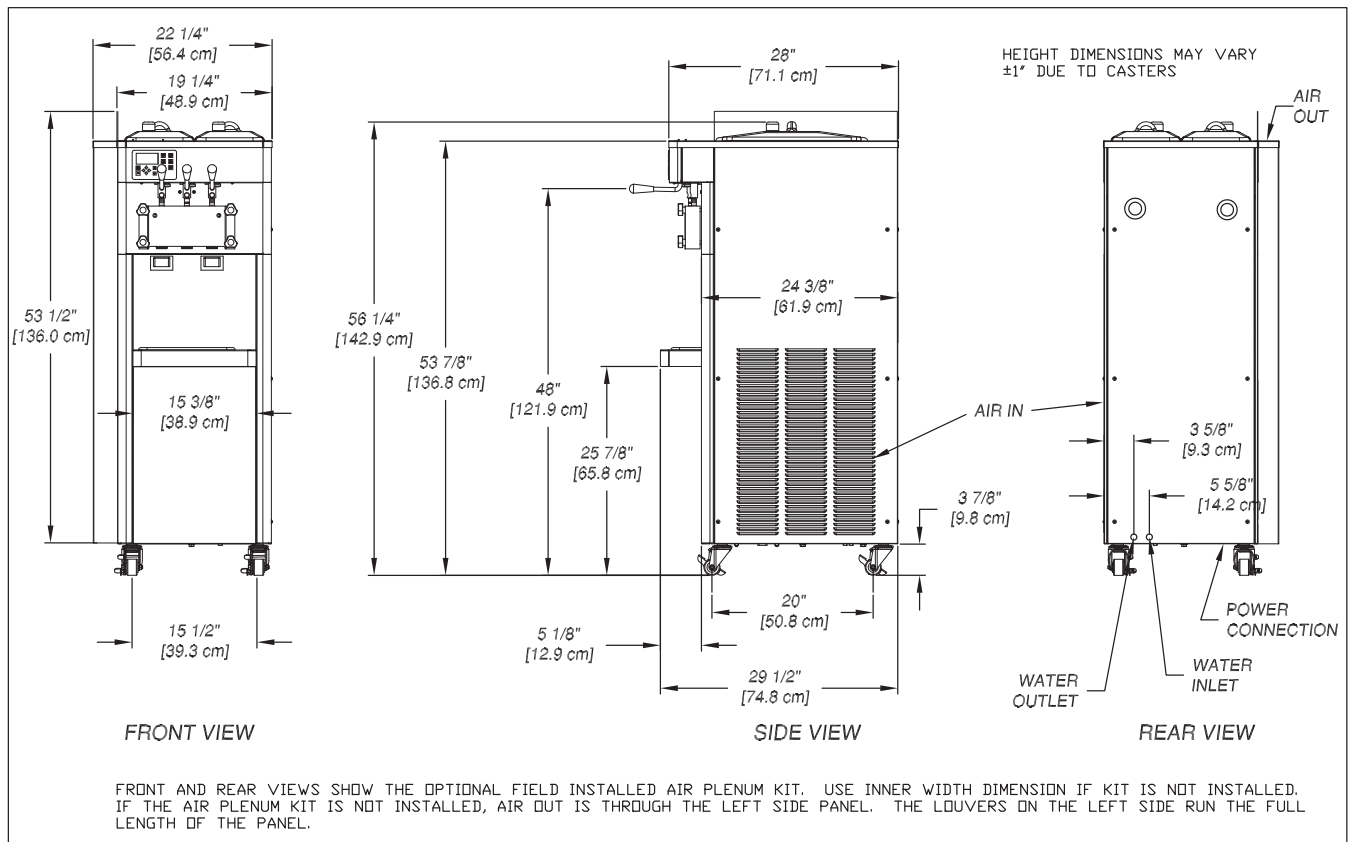

**Figure 1-2 Dimension Specifications (variations on spigot handles and casters available)**

Model F231		
Dimensions	Machine	as shipped
width	19-1/4" (48,9 cm)	32" (81,3 cm)
height	58-1/4" (148,0 cm)	60" (152,4 cm)
depth	28" (71,1 cm)	39" (99,1 cm)
Weight	400 lbs (181,4 kg)	470 lbs (213,1 kg)
Electrical	<b>1 Phase, 208-240 VAC, 60Hz</b>	<b>3 Phase, 208-240 VAC, 60Hz</b>
running amps	12A	10A
connection type	NEMA 6-20P power cord provided	NEMA L15-20P power cord provided
International Option	1 Phase, 220-240 VAC, 50Hz	
Compressor	12,000 Btu/hr (R-404A)	
Drive Motor	Two - 3/4 hp	
Air Flow	Air cooled units require 3" (7,6 cm) air space on both sides	
Plumbing Fittings	Water cooled units require 1/2" N.P.T. water and drain fittings. Maximum water pressure of 130 psi. Minimum water flow rate of 3 GPM. Ideal EWT of 50°-70°F	
Hopper Volume	Two - 3 gallon (11,35 liters)	
Freezing Cylinder Volume	Two - 0.85 gallon (3,22 liters)	

Menu	Display	F231
<b>Basic</b>	Enable Control	Consistency/Consistency
	CutOut Consist Offset	7
	CutIn Consist Offset	20
	CutIn Temp	19.5 °F
	CutOut Temperature	19 °F
	Cycles In Serve Mode	20
<b>Advanced</b>	Standby On Time	10 sec
	Standby Off Time	360 sec
	Standby Time	120 min
	Stir On	15 sec
	Stir Off	600 sec
	Sleep 2 CutIn	33 °F
	Sleep 2 CutOut	30.5 °F
	Default Off Time	300 sec
<b>Storage</b>	Storage Refrigeration	Active
	Storage CutIn	37.5 °F
	Storage CutOut	32 °F
	Storage Offset	4 °F
	Storage Off Time	13 min
	Storage On Time	130 sec
	Storage Max On	3 min
	Storage Recovery	4 min
	Storage Too Warm	50 °F
	Storage Too Warm	2 hr

	F231
<b>Refrigerant</b>	R-404A
<b>Charge</b>	(W/C) 32 oz (A/C) 42 oz
<b>Suction Pressure (at 72°F)</b>	One Cylinder 18-22 psig Both Cylinders 22-27 psig Hopper Only 14 psig
<b>Discharge Pressure</b>	225-235 psig
<b>Hot Gas Bypass Pressure</b>	14 psig (only hopper running)
<b>EPR Valve</b>	68-70 psig

## IntelliTec™ Control Modes of Operation

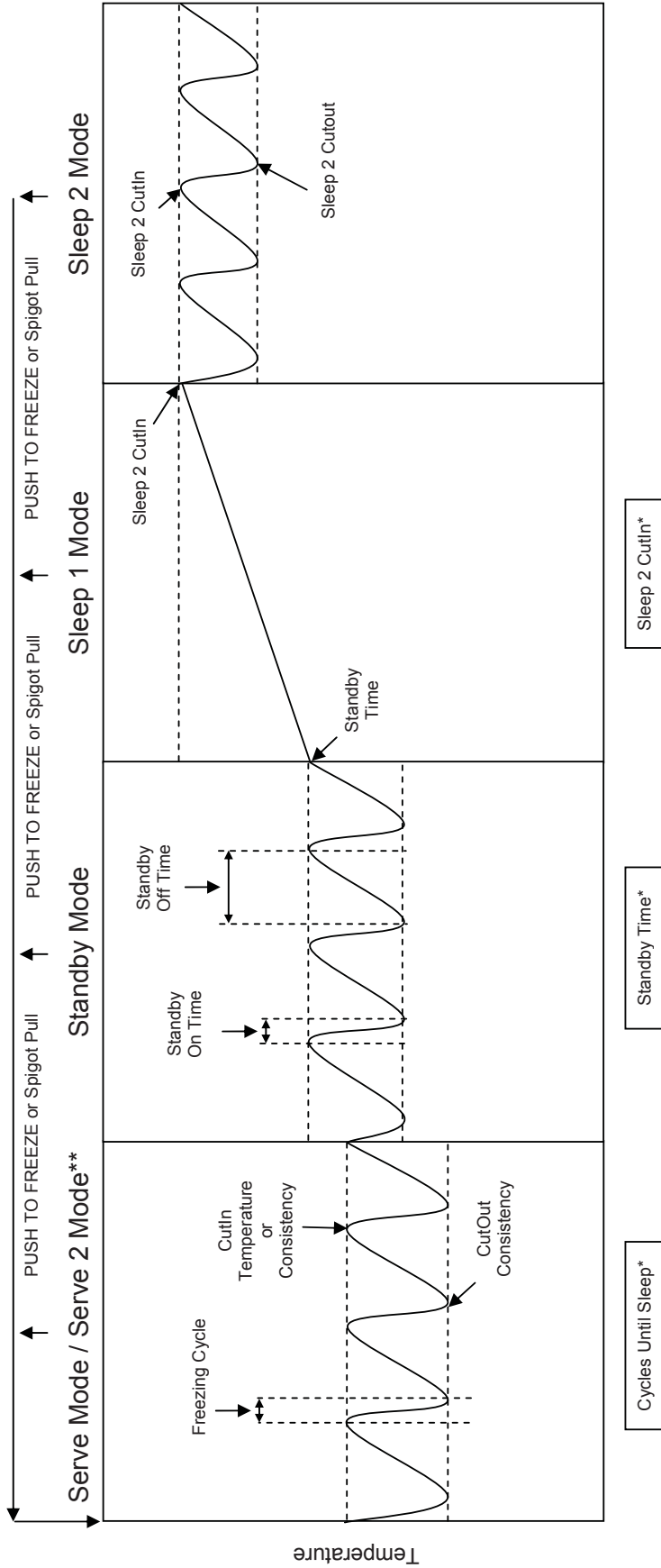

\* Resets any time the PUSH TO FREEZE button is pressed or a spigot is pulled. In order for the mode to change, it has to go through its normal cycles without reset.

\*\* After the Cycles Until Sleep number is met, Serve 2 Mode goes directly into Sleep 2 Mode.

### Note:

- 1) A stir cycle will start in each mode. The cycle is independent of the freezing cycle.
- 2) Normal start up mode is Sleep 1 when the number of cycles is set below 99. When cycles are set higher than 99, the freezer will start up in the Serve mode.
- 3) Sensor failure will keep the control in Serve and Standby modes only.
- 4) A freeze cycle will reset the stir cycle.
- 5) Serve Mode is active for the Temperature/Consistency setting and monitors CutIn Temperature. Serve 2 Mode is active for the Consistency/Consistency setting and monitors CutIn Consistency. Both use CutOut Consistency.

## SECTION 2 INSTALLATION INSTRUCTIONS

### 2.1 SAFETY PRECAUTIONS

Do not attempt to operate the machine until the safety precautions and operating instructions in this manual are read completely and are thoroughly understood.

Take notice of all warning labels on the machine. The labels have been put there to help maintain a safe working environment. The labels have been designed to withstand washing and cleaning. All labels must remain legible for the life of the machine. Labels should be checked periodically to be sure they can be recognized as warning labels.

If danger, warning or caution labels are needed, indicate the part number, type of label, location of label, and quantity required along with your address and mail to:

**STOELTING**  
**ATTENTION: Customer Service**  
**502 Hwy. 67**  
**Kiel, Wisconsin 53042**

### 2.2 SHIPMENT AND TRANSIT

The machine has been assembled, operated and inspected at the factory. Upon arrival at the final destination, the entire machine must be checked for any damage which may have occurred during transit.

With the method of packaging used, the machine should arrive in excellent condition. THE CARRIER IS RESPONSIBLE FOR ALL DAMAGE IN TRANSIT, WHETHER VISIBLE OR CONCEALED. Do not pay the freight bill until the machine has been checked for damage. Have the carrier note any visible damage on the freight bill. If concealed damage and/or shortage is found later, advise the carrier within 10 days and request inspection. The customer must place claim for damages and/or shortages in shipment with the carrier. Stoelting, Inc. cannot make any claims against the carrier.

### 2.3 MACHINE INSTALLATION



#### WARNING

**Installation must be completed by a qualified electrician/refrigeration specialist.**

Incorrect installation may cause personal injury, severe damage to the machine and will void factory warranty.

Installation of the machine involves moving the machine close to its permanent location, removing all crating, setting in place, assembling parts, and cleaning.

- A. Uncrate the machine.
- B. Install the four casters. Turn the threaded end into the machine until no threads are showing. To level, turn out casters no more than 1/4" maximum, then tighten all jam nuts.
- C. The machine must be placed in a solid level position.

#### NOTE

*Accurate leveling is necessary for correct drainage of freezing cylinder and to insure correct overrun.*

- D. Machines with air cooled condensers require a minimum of 3" (7,5cm) of space on both sides for proper circulation. (Fig. 2-1)
- E. Machines that have a water cooled condenser require 1/2" NPT supply and drain fittings.



**Figure 2-1 Space and Ventilation Requirements**

### 2.4 INSTALLING PERMANENT WIRING

To install wiring follow the steps below:

- A. Refer to the nameplate on the side panel of the machine for specific electrical requirements. Make sure the power source in the building matches the nameplate requirements.
- B. Remove the back panel and the junction box cover located at the bottom of the machine.
- C. Install permanent wiring according to local code.

## 2.5 INITIAL STARTUP OF INTELLITEC2™

Before completing the following procedures, follow the steps in Section 3 to disassemble, clean, lubricate and sanitize the machine.

### NOTE

*IntelliTec2™ startup must be completed by a trained authorized service provider or Stoelting distributor.*

- A. Locate a copy of the latest firmware file (ueziimage.rom) and service contact file (info.txt).
- B. Modify the info.txt file with information from the service company using the instructions in the file.
- C. Put the firmware file and service contact file onto the root level of a USB flash drive (do not put the files into any folder).
- D. Insert the flash drive into the USB port of the machine.
- E. Fill the mix containers in the cabinet with mix.
- F. Connect power to the machine and press the Main Power On/Off button and the Pump On/Off buttons.

### SETTING CONTACT INFORMATION

- A. When the Current Status screen is displayed, press the left arrow button to access the passcode selection screen. Press the right arrow, SET, then the SEL button.

```

Main Menu
- Technician Level Access
_ Fine Consistency Adjustment
_ Performance
_ Modify Settings
_ Utilities
_ Errors and Statistics
    
```

**Figure 2-2**

- B. After the password is accepted, use the arrows to move the cursor to the Modify Settings option and press the SEL button. Then move the cursor to the User Preferences and press the SEL button.
- C. On the User Preferences screen move the cursor to the Contact Information USB Update and press the SEL button.

```

User Preferences
_ Language                      English
_ Temp Units                     Fahrenheit(°F)
_ Service Contact Information
_ Contact Information USB Update
    
```

**Figure 2-3**

- D. The screen will change and show "File Found" for a quick second while it updates the information.
- E. After updating the contact information, the screen will show the Service Contact Information page.

```

Service Contact Information
Name
  Stoelting
Telephone Number
  920 - 894 - 2293
Unit Serial Number
  00000000
Version                               00.00/00.00
    
```

**Figure 2-4**

- F. Press the left arrow button to go back to the Current Status screen. Then press the right arrow to go to the Main Menu.

### NOTE

*If you press the left arrow from the Current Status screen it will ask for the password. Press the right arrow, SET, then the SEL button.*

### UPDATING FIRMWARE

If the control has the latest firmware, skip this section and go to the Motor Calibration section.

- A. Move the cursor to the Utilities option and press the SEL button. Then move the cursor to the Next Utilities Menu and press the SEL button.
- B. On the Utilities (2 of 2) screen move the cursor to the Update IO Firmware option and press the SEL button.
- C. On the Update IO Firmware screen select the Yes option.

```

Update IO Firmware

Bootloader Version 655.35
This will update the IO Firmware
Are you sure
you want to do that
_ No
_ Yes
    
```

**Figure 2-5**

- D. This process will take about 4 minutes. DO NOT INTERRUPT this upload. The control will go through several process steps and return to the Main Menu when the update is completed.

- E. Press the left arrow button to go back to the Current Status screen. Then press the right arrow to go to the Main Menu.

**NOTE**

*If you press the left arrow from the Current Status screen it will ask for the password. Press the right arrow, SET, then the SEL button.*

**MOTOR CALIBRATION**

Before starting the motor calibration, be sure there is liquid mix in the freezing cylinder.

- A. Select the Utilities option, then the Next Utilities option. Select the Unit Calibration then the Motor Calibration option.
- B. Move the cursor over the Left side and press the SEL button then move the cursor over the Right side and press the SEL button.

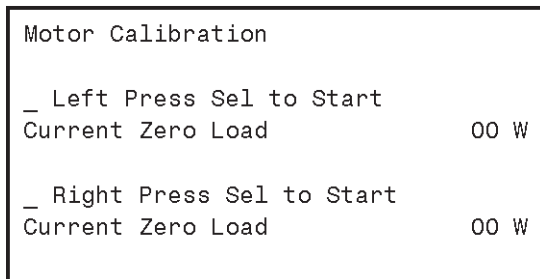

**Figure 2-6**

**NOTE**

*The motor calibration can be done for both sides simultaneously.*

- C. After the calibration is complete, press the Main Power On/Off button to turn the machine off and remove the USB flash drive.

**SETTING CONTROL**

- A. Press the Main Power On/Off button.
- B. When the Current Status screen is displayed, press the left arrow button to access the passcode selection screen. Press the right arrow, SET, then the SEL button.
- C. Move the cursor to the Modify Settings option and press the SEL button. Then move the cursor to the Time and Date option and press the SEL button and adjust the settings as required.
  1. Press the SEL button to enter the Modify Time and Date screen.
  2. Move the cursor to the setting that needs to be changed and press the SET button.
  3. Use the arrow buttons to change the setting and press the SET button to save the change.

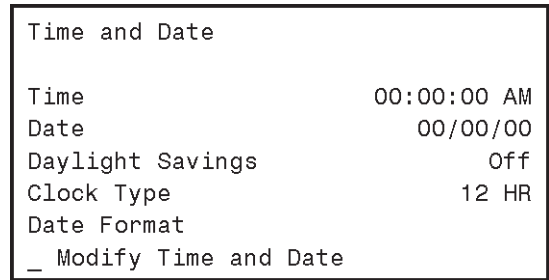

**Figure 2-7**

- D. Press the Push to Freeze button and let the machine cycle 4-5 times.
- E. Draw product from the barrel immediately after the compressor cycles off after the fifth time and test the product for consistency and temperature.
- F. Adjust the product consistency by increasing or decreasing the CutIn Consist Offset setting.
- G. If the machine short cycles (short on/off compressor run times), change the settings as follows:
  1. If the product is too soft, increase the CutOut Consist Offset.
  2. If the product is too firm, decrease the CutIn Consist Offset.
- H. Allow the machine to cycle 3-4 more times after making the adjustment.
- I. After 3-4 cycles, draw product from the barrel immediately after the compressor cycles on.  
  
If the product is servable when the compressor cycles on but it is too firm at the end of the cycle, reduce the CutOut Consist Offset.

**SETTING DISCHARGE PRESSURE ON WATER COOLED MACHINES**

- A. Water cooled machines require the water condenser valves to be adjusted to maintain a discharge pressure of 225-235 psig. When adjusting the discharge pressure the machine must be under a full load with both cylinders running and the hopper running (if applicable).



## SECTION 3 INITIAL SET-UP AND OPERATION

### 3.1 OPERATOR'S SAFETY PRECAUTIONS

SAFE OPERATION IS NO ACCIDENT; observe these rules:

- A. Know the machine. Read and understand the Operating Instructions.
- B. Notice all warning labels on the machine.
- C. Wear proper clothing. Avoid loose fitting garments, and remove watches, rings or jewelry that could cause a serious accident.
- D. Maintain a clean work area. Avoid accidents by cleaning up the area and keeping it clean.
- E. Stay alert at all times. Know which switch, push button or control you are about to use and what effect it is going to have.
- F. Disconnect power for maintenance. Never attempt to repair or perform maintenance on the machine until the main electrical power has been disconnected.
- G. Do not operate under unsafe operating conditions. Never operate the machine if unusual or excessive noise or vibration occurs.

### 3.2 OPERATING CONTROLS AND INDICATORS

Before operating the machine, it is required that the operator know the function of each operating control. Refer to Figure 3-1 for the location of the operating controls on the machine. For the information regarding error codes displayed on the control panel, refer to the troubleshooting section of this manual.

#### A. INTELLITEC2™ TOUCHPAD



#### WARNING

High voltage will shock, burn or cause death. The OFF-ON switch must be placed in the OFF position prior to disassembling for cleaning or servicing. Do not operate machine with panels removed.

#### Main Power On/Off

The Main Power button is used to supply power to the IntelliTec2™ control, the freezing cylinder circuits and the storage refrigeration system. When the machine is first plugged in, the control defaults to the On status with power to the hopper only. If the Main Power On/Off button is pressed when the machine is on, the machine will turn off and a status message will be displayed on the screen.



Figure 3-1 Machine Controls

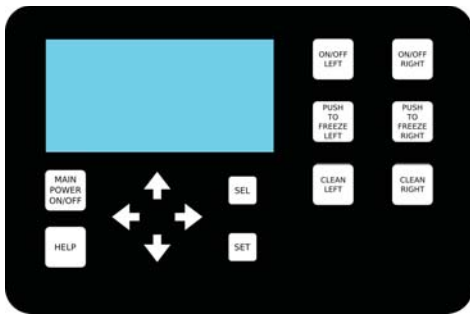

Figure 3-2 IntelliTec2™ Control

### Help

Pressing the Help button will display help information dependant on the cursor's location. Pressing the Help button again will exit the help screen.

### Selection Button (SEL)

The SEL button is used by technicians to select menu options.

### Set Button (SET)

The SET button is used by technicians to save changes when modifying control settings.

### On/Off Button

Power to the freezing cylinders can then be controlled with the On/Off Left and On/Off Right switches.

### Push to Freeze Button

Pressing the PUSH TO FREEZE button initiates "Serve Mode".

### Clean Button

The CLEAN button initiates "Clean Mode".

### Arrow Buttons (←, ↑, →, ↓)

The arrow buttons are used by technicians to navigate through the control readings and settings.

## B. SPIGOT SWITCH

The spigot switch is mounted to the spigot cam assembly behind the header panel. When the spigot is opened to dispense product, the spigot switch opens and the "Serve Mode" begins.

## C. DISPENSE RATE ADJUSTOR

The dispense rate adjustor is located under the header panel, to the immediate right of the spigot handles. Turning the knob counterclockwise will decrease the dispense rate.

## D. MIX LOW LIGHTS

The mix low lights are located at the back of the F231. There is a light for each freezing cylinder. A steady light signifies a low mix condition. A blinking light signifies an error. The light will automatically turn off when the condition has been resolved.

## E. USB ACCESS PORT

The USB access port is located on the right side panel of the machine. The port is used by technicians to import firmware and export machine statistics.

## 3.3 DISASSEMBLY OF MACHINE PARTS

Before using the machine for the first time, complete machine disassembly, cleaning and sanitizing procedures need to be followed. Routine cleaning intervals and procedures must comply with the local and state health codes. Inspection for worn or broken parts should be made at every disassembly of the machine. All worn or broken parts should be replaced to ensure safety to both the operator and the customer and to maintain good machine performance and a quality product. Check the wear line on the auger flights on a regular basis (Fig. 3-3) and replace as needed. Frequency of cleaning must comply with the local health regulations.



Figure 3-3 Auger Flight Wear

To disassemble the machine, refer to the following steps:

### A. REMOVING MIX

For the first time cleaning the machine, skip to part B. Disassembly of Front Door.

1. Press the Clean button. After mix has melted (about 5 minutes) open the spigot to drain the mix.
2. Fill the hopper with 2 gallons (8 liters) of cool tap water.
3. Press the Clean button to run the machine. After 30 seconds press the Clean button again to stop the auger.
4. Drain the water out of the machine.

### NOTE

*If the water does not drain clear, repeat steps 2-4.*

5. Use Stera-Sheen or equivalent sanitizing solution mixed according to manufacturer's instructions to provide a 100 parts per million strength solution. Mix sanitizer in quantities of no less than 2 gallons of 90° to 110°F (32°C to 43°C) water. Any sanitizer must be used only in accordance with the manufacturer's instructions.
6. Pour the sanitizer into the hopper.
7. Using brushes provided, scrub the hopper.
8. After 5 minutes, drain the sanitizer out of the freezing cylinder.

## B. DISASSEMBLY OF FRONT DOOR

1. Turn the machine off by pressing the Main Freezer Power Off/On button on the IntelliTec2™ control.
2. Remove the knobs on the front door.
3. Remove the front door by pulling it off the studs.
4. Remove the spigot through the bottom of the front door.
5. Remove all o-rings from parts by first wiping off the lubrication using a clean towel. Then squeeze the o-ring upward to form a loop (Fig. 3-4). Roll the o-ring out of the groove.



Figure 3-4 Removing O-Ring

## C. DISASSEMBLY OF AUGER

1. Remove the front auger support and bushing.
2. Remove the auger assembly from the machine. Pull the auger out of the machine barrel slowly. As the auger is being pulled out, carefully remove each of the plastic flights with springs.
3. Keep the rear of the auger tipped up once it is clear of the freezing cylinder to prevent the rear seal assembly from dropping.
4. Wipe the spline lubricant off of the hex end of the auger with a paper towel. Remove the rear seal assembly (Fig. 3-5).
5. Unscrew the springs from the auger flights.



Figure 3-5 Rear Seal Assembly

## 3.4 CLEANING DISASSEMBLED PARTS

Disassembled machine parts require complete cleaning, sanitizing and air drying before assembling. Local and state health codes will dictate the procedure required. Some state health codes require a four sink process (pre-wash, wash, rinse, sanitize, air dry), while others require a three sink process (without the pre-wash step). The following procedures are a general guideline only. Consult your local and state health codes for the procedures required in your location.

- A. Prepare Stera-Sheen or equivalent cleaner in 2 gallons of 90° to 110°F (32° to 43°C) water following manufacturers instructions. Place all parts in the solution and clean with provided brushes.
- B. Rinse all parts with clean 90° to 110°F (32° to 43°C) water.
- C. Wash the hopper and freezing cylinder with the Stera-Sheen solution and brushes provided.
- D. Clean the rear seal surfaces from the inside of the freezing cylinder with the Stera-Sheen Solution.

## 3.5 SANITIZING MACHINE PARTS

- A. Use Stera-Sheen or equivalent sanitizing solution mixed according to manufacturer's instructions to provide a 100 parts per million strength solution. Mix sanitizer in quantities of no less than 2 gallons of 90° to 110°F (32°C to 43°C) water. Any sanitizer must be used only in accordance with the manufacturer's instructions.
- B. Place all parts in the sanitizing solution for 5 minutes, then remove and let air dry completely before assembling in machine.

## 3.6 CLEANING THE MACHINE

The exterior should be kept clean at all times to preserve the luster of the stainless steel. A high grade of stainless steel has been used on the machine to ease cleanup. To remove spilled or dried mix, wash the exterior with 90° to 110°F (32°C to 43°C) Stera-Sheen solution or equivalent cleaner and wipe dry.

Do not use highly abrasive materials, as they will mar the finish. Use a soft cloth or sponge to apply the solution. For best results, wipe with the grain of the steel.

- A. Clean the rear seal surface from inside of the freezing cylinder.

- B. Using sanitizing solution and the large barrel brush provided, sanitize the freezing cylinder by dipping the brush in the sanitizing solution and brushing the inside of the freezing cylinder.

**NOTE**

*Do not let sanitizing solution sit overnight in the freezing cylinder.*

- C. Remove the drip tray by pulling from the front panel. Clean and replace the drip tray.

**3.7 ASSEMBLING MACHINE**

To assemble the machine parts, refer to the following steps:

**NOTICE**

*Petrol-Gel sanitary lubricant or equivalent must be used when lubrication of machine parts is specified.*

**NOTICE**

*The United States Department of Agriculture and the Food and Drug Administration require that lubricants used on food processing equipment be certified for this use. Use lubricants only in accordance with the manufacturer's instructions.*

- A. Assemble all o-rings onto parts dry, without lubrication. Then apply a thin film of sanitary lubricant to exposed surfaces of the o-rings.
- B. Lubricate the rear seal area on the auger shaft with a thin layer of sanitary lubricant. Install the rear seal o-ring. Lubricate the outside of the rear seal o-ring with sanitary lubricant.
- C. Lubricate the inside metal surface of the rear seal and install it onto the auger shaft. **DO NOT** lubricate the outside of the rear auger seal (Fig. 3-6).



**Figure 3-6 Lubricate Rear Seal**

- D. Lubricate the hex drive end of the auger with a small amount of spline lubricant. A small container of spline lubricant is shipped with the machine.
- E. Screw the springs onto the studs in the plastic flights. The springs must be screwed into the flights completely to provide proper compression.
- F. Install the two plastic flights onto the rear of the auger and insert it part way into the freezing cylinder.
- G. Install the remaining plastic flights, push the auger into the freezing cylinder and rotate slowly until the auger engages the drive shaft.
- H. Apply a thin layer of sanitary lubricant to the inside and outside of the auger support bushing. Install the bushing onto the auger support and install the auger support into the front of the auger. Rotate the auger support so that one leg of the support points straight up.
- I. Apply a thin layer of sanitary lubricant to the o-rings on the spigot body and install the spigot body through the bottom of the front door.
- K. Apply a thin film of sanitary lubricant to the door seal o-ring and fit it into the groove on the rear of the front door.
- M. Place the front door assembly on the mounting studs and the push front door against the machine carefully.
- N. Secure the front door to the machine by placing the knobs on the studs and tightening until finger tight. Do not overtighten. A proper o-ring seal can be observed through the transparent front door.

**3.8 SANITIZING**

Sanitizing must be done after the machine is clean and just before the machine is filled with mix. Sanitizing the night before is not effective. However, you should always clean the machine and parts after using it.

**NOTE**

*The United States Department of Agriculture and the Food and Drug Administration require that all cleaning and sanitizing solutions used with food processing equipment be certified for this use.*

When sanitizing the machine, refer to local sanitary regulations for applicable codes and recommended sanitizing products and procedures. The frequency of sanitizing must comply with local health regulations. Mix sanitizer according to manufacturer's instructions to provide a 100 parts per million strength solution. Mix sanitizer in quantities of no less than 2 gallons of 90°F to 110°F (32°C to 43°C) water. Allow sanitizer to contact the surfaces to be sanitized for 5 minutes. Any sanitizer must be used only in accordance with the manufacturer's instructions.

- A. Prepare 2 gallons of Stera-Sheen sanitizing solution following the manufacturer's instructions.
- B. Install the mix inlet regulator into the hopper.
- C. Pour the sanitizing solution into the hopper.
- D. Make sure the display shows the freezing cylinder is off. If it is not, press the On/Off Left or On/Off Right button to turn it off.
- G. When the product is at 75% consistency, the display will read "SERVE". Open the spigot to dispense product.
- H. The machine dispenses product at a reasonable draw rate. If the machine is overdrawn, the result is a soft product or a product that will not dispense at all. If this occurs, allow the machine to run for approximately 30 seconds before dispensing more product. A dispense rate adjuster is located under the header panel, to the immediate right of the spigot handle. Turning the knob counterclockwise will decrease the dispense rate.

**NOTE**

*If the freezing cylinder is not off, the control will not go into Clean mode. This is to protect from accidentally going into Clean mode.*

- E. Press the CLEAN button.
- F. Check for leaks.
  - 1. Check for leaks at the front door seals.
  - 2. Check the drain tray located under the front door for leaks coming from the rear of the rear auger seal.
- G. Using a sanitized soft bristle brush (or equivalent) dipped in sanitizing solution, clean the hopper sides, mix inlet regulator and underside of the hopper cover.
- H. After five minutes, open the spigot to expel sanitizing solution. Drain all of the solution from the machine.
- I. When the solution has drained, press the CLEAN button to stop the auger. Allow the freezing cylinder to drain completely.
- I. Do not operate the machine when the MIX LOW message is displayed. Refill the mix container immediately.

**NOTE**

*The control has a standby mode for Serve 1 and a sleep mode for Serve 1 and Serve 2. After a preset number of freezing cycles in Serve 1, it will enter the standby mode (followed by sleep mode) and remain there until someone draws product or presses the PUSH TO FREEZE button. In Serve 2 the control directly goes into the Sleep 2 mode. In the sleep mode, the machine will keep the product below 41°F (5°C). Sleep modes do not take the place of cleaning and sanitizing. Federal, State, and local regulatory agencies determine frequency of cleaning and sanitizing.*

The machine is now sanitized and ready for adding mix.

**3.9 FREEZE DOWN AND OPERATION**

- A. Sanitize immediately before use.
- B. Make sure the display shows the freezing cylinder is off. If it is not, press the On/Off Left or On/Off Right button to turn it off.
- C. Fill the hopper with at least 2.5 gallons of mix.
- D. Place a container under the spigot and open the spigot to allow the mix to flush out about 8 ounces (0.23 liters) of sanitizing solution and liquid mix.
- E. Press the On/Off button for the cylinder.
- F. Press the PUSH TO FREEZE button.

**3.10 FINE CONSISTENCY ADJUSTMENT**

If the product consistency needs to be adjusted, use the Fine Consistency Adjustment. To access the setting, the Associate level password must be entered. Follow the steps below for the Fine Consistency Adjustment.

- A. Press the left arrow from the Current Status screen.
- B. Press the right arrow then the SEL button from the Password screen. After the password is accepted, move the cursor to the Fine Consistency Adjustment option and press the SEL button.
- C. On the Fine Consistency Adjustment screen, press the SEL button and use the arrows to modify the setting. Adjust the Fine Consistency higher to increase the consistency or lower to decrease the consistency.
- D. Press the SET button to save the changes. Make adjustments in increments of 5 for best results.

### 3.11 MIX INFORMATION

Mix can vary considerably from one manufacturer to another. Differences in the amount of butterfat content and quantity and quality of other ingredients have a direct bearing on the finished frozen product. A change in machine performance that cannot be explained by a technical problem may be related to the mix.

Proper product serving temperature varies from one manufacturer's mix to another. Mixes should provide a satisfactory product in the 20°F to 24°F range. Diet and low-carb mixes typically freeze to proper consistency at higher temperatures.

When checking the temperature, stir the thermometer in the frozen product to get an accurate reading.

Old mix, or mix that has been stored at too high a temperature, can result in a finished product that is unsatisfactory. To retard bacteria growth in dairy based mixes, the best storage temperature range is between 33° to 38°F (0.5° to 3.3° C).

## SECTION 4 MAINTENANCE AND ADJUSTMENTS

This section is intended to provide maintenance personnel with a general understanding of the machine adjustments. It is recommended that any adjustments in this section be made by a qualified person.

### 4.1 ACCESSING CONTROL READINGS AND SETTINGS

The readings and settings on the IntelliTec2™ control are accessed by using a keypad sequence. Press the left arrow button from the Current Status screen to access the passcode input screen.

The specific readings and parameters available depend on the keypad sequence entered. The lowest level is Associate and has limited access. The Manager level has access to the majority of screens except Utilities (2 of 2). The Technician level has full access to the control including the Associate and Manager level options.

Following are the keypad sequences for the three levels available.

- Associate**      Press the right arrow then the SEL button.
- Manager**        Press the right arrow, up arrow then the SEL button
- Technician**    Press the right arrow, SET, then the SEL button

### 4.2 NAVIGATION AND MODIFYING SETTINGS

Navigating through the IntelliTec2™ screens is done with the arrow keys on the touchpad. After positioning the cursor on a desired menu, press the SEL button to select that option. If the option is a setting, press the SET button to change the value. Use the arrow keys to change the value. Press the SET button to save the changes.

The SEL button changes the cylinder selection on screens that show the cylinder.

Pressing the left arrow button from any menu will go back one screen. Pressing the left arrow button at the Main Menu screen goes to the Current Status screen.

### 4.3 USER INTERFACE SCREENS

#### A. Current Status

Current Status	01/01/01
	12:34:56
Left	Serve
Right	Sleep 1
Storage Left	On
Storage Right	On
_ Service Company	

The Current Status screen gives an overview of the machine's operation. It shows the mode of the freezing cylinders and the storage refrigeration. If there is an error, the error text description replaces the status information.

The Service Contact Information screen is accessed from the Current Status screen. Move the cursor to the Service Contact Information option and press the SEL button.

#### B. Service Contact Information

Service Contact Information	
Name	Stoelting
Telephone Number	920 - 894 - 2293
Unit Serial Number	00000000
Version	00.00/00.00

The Service Contact Information screen provides the name and telephone number for service. The default is Stoelting Technical Customer Service. The Manager and Technician levels can change the default by selecting the Modify Contact Information option or by uploading the info.txt file.

#### C. Main Menu

Main Menu	
-	Technician Level Access
_	Fine Consistency Adjustment
_	Performance
_	Modify Settings
_	Utilities
_	Errors and Statistics

The Main Menu screen provides access to all the readings and settings on the IntelliTec2™ control. To access the Main Menu, use one of the keypad sequences from Section 4.1. The example above shows the options available when entering the Manager or Technician keypad sequence. The Associate will only see the Fine Consistency Adjustment option.

## D. Fine Consistency Adjustment

Fine Consistency Adjustment	
Cylinder	Right
Changing the fine consistency change the firmness of the product.	
Consistency CutIn Limit	00
Consistency CutOut Limit	00
_ Fine Consistency	000

Product consistency can be adjusted by the Associate level by using the Fine Consistency Adjustment screen. Increasing the Fine Consistency number increases the product consistency (firmer product).

The Consistency Limits show the Fine Consistency adjustment added to the Consistency number.

### 4.4 PERFORMANCE SCREENS

#### A. Performance (1 of 2)

Performance (1 of 2)	
Cylinder	Right
Consistency 000.00	
Cylinder Temp	-000.0°F
Motor Amps	00.000A
Input Voltage	000.0V

The Performance screens display the current status of the machine. These screens are available to the Manager and Technician levels. Press the right arrow to go to the second screen.

#### Cylinder

The performance information displayed is for the selected cylinder. To change cylinders press the SEL button.

#### Consistency\*

This is the current consistency number of the selected cylinder. The consistency number represents how thick or thin the product in the freezing cylinder is. A higher number means the product is thicker. Go to the Modify Operating Settings menu to change the operating setting.

#### Cylinder Temperature

This is the current suction line temperature of the selected cylinder.

#### Motor Amps\*

This is the current motor amps of the selected cylinder.

#### Input Voltage\*

This is the current voltage of the selected cylinder.

\* Only shown when the drive motor is running

## B. Performance (2 of 2)

Performance (2 of 2)	
Cylinder	Right
Ambient Temp	-000.0°F
Storage Temp	-000.0°F
Number of Cycles	000
Error Status	No Error

The Performance screens display the current status of the machine. This screen shows the current ambient temperature, storage temperature and number of cycles since the Push to Freeze button was pressed or the spigot was pulled. Press the left arrow to go to the first screen.

### 4.5 SETTINGS SCREENS

#### A. Modify Operating Settings

Modify Operating Settings	
_ Basic Settings	
_ Advanced Settings	
_ Storage Settings	
_ User Preferences	
_ Time and Date	

This menu provides access to view and change the different operating settings on the machine. The Manager and Technician levels have access to these screens.

#### B. Basic Settings

Basic Settings	
Cylinder	Right
_ Enable Control	Consist-Consist
_ CutOut Consist Offset	000
_ CutIn Consist Offset	000
_ CutIn Temp	00.0°F
_ CutOut Temp	00.0°F
_ Cycles In Serve Mode	000

This menu contains settings for the control style, CutIn and CutOut, cycles in serve mode and auger cycle times. This screen is available to the Technician level.

**Cylinder** can be changed by pressing the SEL button.

The **Enable Control** setting determines the cutin and cutout style. The options are Consistency-Consistency, Temperature-Consistency or Temperature-Temperature.

Setting the control to Consistency-Consistency enables Serve 2 Mode (instead of Serve 1 Mode). Serve 2 Mode extends the post stir to prevent short cycling the compressor and a possible misread of the consistency in the freezing cylinder.

**CutOut Consistency Offset** is a number that represents the point at which a freezing cycle will end in Consistency-Consistency or Temperature-Consistency style. The actual cutout value is the sum of this number, the Cutin Consistency Offset and the Motor Zero Load numbers.

**CutIn Consistency Offset** is a number that represents the point at which a freezing cycle will start in Consistency-Consistency style. The actual cutout value is the sum of this number and the Motor Zero Load number.

**CutIn Temperature** is the suction line temperature in the cylinder when a freezing cycle will start in Temperature-Consistency or Temperature-Temperature style.

**CutOut Temperature** is the suction line temperature in the cylinder when a freezing cycle will stop in Temperature-Temperature style.

**Cycles In Serve Mode** is a count of the number of freezing cycles.

### C. Advanced Settings (1 of 2)

Advanced Settings (1 of 2)	
Cylinder	Right
_ Standby On Time	0000 sec
_ Standby Off Time	0000 sec
_ Standby Time	000 min
_ Stir On	0000 sec
_ Stir Off	0000 sec

The Advanced Settings menu contains standby and sleep mode adjustments and is available to the Manager and Technician levels. Press the right arrow to go to the second screen.

**Cylinder** can be changed by pressing the SEL button.

The **Standby On Time** setting determines the length of the freezing cycle in Standby Mode.

The **Standby Off Time** setting determines the length between freezing cycles in Standby Mode.

The **Standby Time** setting determines the total amount of time in Standby Mode.

**Stir On** is the amount of time that the auger rotates during the stir cycle. Stir cycles occur in Serve Mode, Standby Mode and Sleep 2 Mode.

**Stir Off** is the amount of time between stir cycles. Stir cycles occur in Serve Mode, Standby Mode and Sleep 2 Mode.

### D. Advanced Settings (2 of 2)

Advanced Settings (2 of 2)	
Cylinder	Right
_ Sleep 2 CutIn	-00.0°F
_ Sleep 2 CutOut	-00.0°F
_ Default Off Time	0000 sec

The Advanced Settings menu contains standby and sleep mode adjustments and is available to the Manager and Technician levels. Press the left arrow to go to the first screen.

**Sleep 2 CutIn** is the temperature that a freezing cycle starts in Sleep 2 Mode.

**Sleep 2 CutOut** is the temperature that a freezing cycle stops in Sleep 2 Mode.

**Default Off Time** is the maximum time between freezing cycles during Serve Mode or Serve 2 Mode.

### E. Storage Settings (1 of 2)

Storage Settings (1 of 2)	
_ Storage Refrigeration	Active
_ Storage CutIn	-00.0°F
_ Storage CutOut	-00.0°F
_ Storage Degree Offset	00°F
_ Storage Off Time	00 min
_ Storage On Time	0000 sec

This Storage Settings menu contains storage refrigeration parameters and is available to the Technician level. Press the right arrow to go to the second screen.

**Storage Refrigeration** can be set to Active or Suspend. Active is the normal setting. Suspend is used only for troubleshooting and setting an AXV. Never have refrigeration set to Suspend during normal operation.

**Storage CutIn** is the temperature at which the storage refrigeration cycle starts. This is how warm it will get before starting a storage refrigeration cycle.

**Storage CutOut** is the temperature at which the storage refrigeration cycle stops. This is how low the temperature will get before ending the storage refrigeration cycle.

The **Storage Offset** value is added to the storage temperature reading to determine if storage refrigeration starts with a freezing cycle. This setting helps prevent short cycling and saves energy.

The **Storage Off** setting determines the time between storage refrigeration cycles during a sensor failure.

The **Storage On** setting determines the length of a storage refrigeration cycle during a sensor failure.

## F. Storage Settings (2 of 2)

Storage Settings (2 of 2)	
_ Storage Max On	00 min
_ Storage Recovery	0 min
_ Storage Too Warm	00.0°F
_ Storage Too Warm	000 min

This Storage Settings menu contains storage refrigeration parameters and is available to the Manager and Technician levels. Press the left arrow to go to the first screen.

The **Storage Max On** setting is the maximum time that a storage refrigeration cycle will run.

The **Storage Recovery** setting is the minimum time between storage refrigeration cycles if the Storage Max On time ends the cycle.

The **Storage Too Warm** values are the temperature and amount of time. When the temperature is above the set temperature for the set period, the Storage too Warm message will be displayed.

## G. User Preferences

User Preferences	
_ Language	English
_ Temp Units	Fahrenheit(°F)
_ Service Contact Information	
_ Contact Information USB Update	

The User Preferences menu contains language options, temperature units, service contact information and touchpad lockup. The screen is available to the Manager and Technician levels.

The **Language** setting changes the language displayed. English and Polish are the only languages currently available.

The **Temperature Units** setting changes the units displayed to Fahrenheit or Celsius.

The **Service Contact Information** option is used to change the service contact details including service company name and number and machine serial number.

## H. Time and Date

Time and Date	
Time	00:00:00 AM
Date	00/00/00
Daylight Savings	Off
Clock Type	12 HR
Date Format	
_ Modify Time and Date	

The Time and Date menu shows the time and date settings. The Manager and Technician levels can change the time and date by using the Modify Time and Date option.

## 4.6 UTILITIES SCREENS

Utilities (1 of 2)	
_ Adjust LCD Contrast	
_ Touchpad Lockup	
_ Export Machine Stats	
_ Clean Options	
Next Utilities Menu	

Utilities (2 of 2)	
_ Testing and Manual Operation	
_ Unit Calibration	
_ Clear Log Data	
_ Restore Factory Defaults	
_ Restore Motor Table Defaults	
_ Reset Unit Configuration	

The Utilities menu gives access for various settings and operations in the control. The Utilities menu is available to the Technician and Manager levels. The Manager level will only have access to the first screen. The Technician level has access to both screens.

### NOTE

*Entering the Utilities (2 of 2) screen automatically shuts off the freezing cylinders.*

## A. Product Selection

Product Selection	
Cylinder	Right
_ Current Product Type	0
CutOut Consistency	000
CutIn Consistency	000
Press Set to change selection	
Press Sel to accept selection	

The Product Selection screen changes CutIn Consistency and CutOut Consistency to a predetermined value depending on the product type.

### B. Adjust LCD Contrast

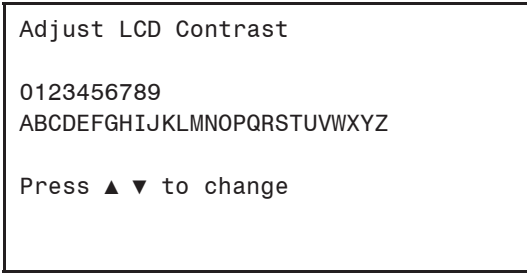

The Adjust LCD Contrast screen adjusts the contrast between the background lighting and the text on the screen.

### C. Touchpad Lockup

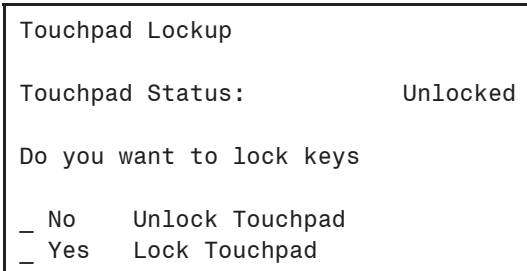

The Touchpad Lockup is used to lock and unlock the keypad for self service locations.

### D. Export Machine Stats

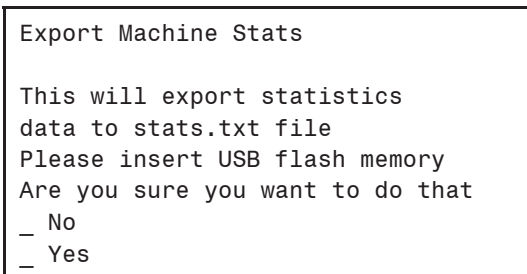

The Export Machine Stats screen allows you to export all the data and statistics stored in the control. Connect a USB flash drive to the port on the side of the machine and select the yes option.

### E. Clean Options

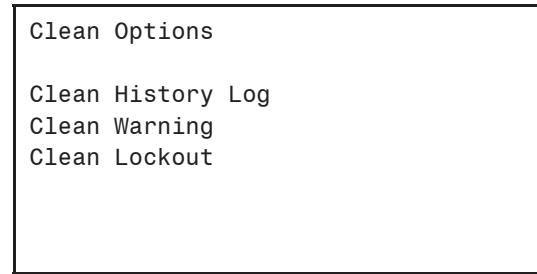

The Clean Options Menu gives access to the Clean History Log and Clean Lockout options.

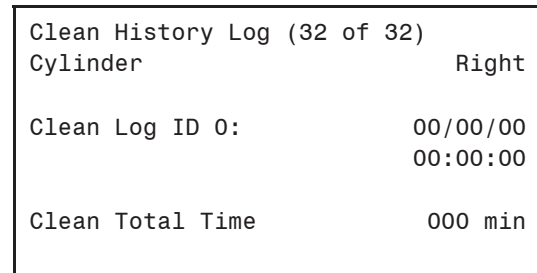

The **Clean History Log** screen shows the date, time and duration of the last 32 clean cycles.

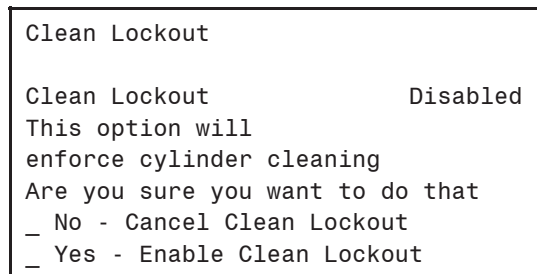
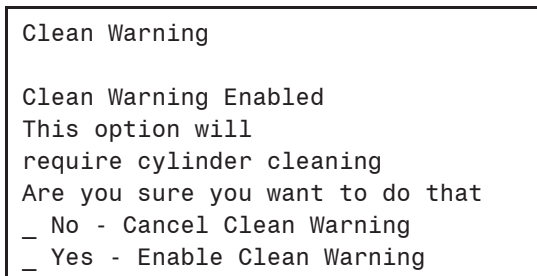

The **Clean Warning** and **Clean Lockout** screens are used to enable the clean warning mode or the clean lockout mode. When one of the modes is enabled and the machine is not cleaned within a specified period, the machine will either display a warning (for warning mode) or remain in sleep mode and not go into serve mode (for lockout mode).

## F. Testing and Manual Operation

```

Testing and Manual Operation
Select below for testing

_ Left Output Control
_ Right Output Control
_ Left / Right Monitoring
    
```

The Testing and Manual Operation menu provides access for individual components to be energized to assist with troubleshooting. There are also test monitoring screens that provide details of the machine status during testing. Any energized component will deenergize after leaving the Testing and Manual Operations menu.

```

Testing and Manual Ops,      Left
_ Drive Motor                Off
_ Fan Motor                  Off
_ Liquid Solenoid            Off
_ Compressor                 Off
_ Refer Solenoid             Off
_ Aux Solenoid               Off
_ Pump Motor                 Off
    
```

```

Test Monitoring (1 of 3)
Cylinder                      Right
CRC Errors Dis/IO             0/6791
Motor Voltage                  0.0 V
Motor Current                  0.000
I/V Phase Angle               0.0°
Frequency                      0.0 Hz
Consistency                    0.0
    
```

```

Test Monitoring (2 of 3)
Cylinder                      Right
CRC Errors Dis/IO             0/12
Ambient Temp                  +00.0°F
Cylinder Temp                  +00.0°F
Hopper Temp                    +00.0°F
Pressure Sensor
Pressure Sw                    On
    
```

```

Test Monitoring (3 of 3)
Cylinder                      Right
CRC Errors Dis/IO             0/12
Cabinet Door                  Closed
Spigot                        Closed
Door                          Closed
Hi Pressure                    No
Liquid Level                   Low
    
```

Selecting Left or Right Output Control goes to a screen that allows motors, solenoids or the compressor to be individually activated. Activate by moving the cursor to the desired component and press the SET button.

Selecting Left/Right Monitoring goes to screens that show current statistics of the selected cylinder.

The Test Monitoring screens can be used for immediate feedback when troubleshooting. For example the spigot switch can be tested by opening the spigot and observing if the status text changes from "Closed" to "Open".

## G. Motor Calibration

```

Motor Zero Load Calibration

_ Left Press Sel to Start
Current Zero Load              00 W

_ Right Press Sel to Start
Current Zero Load              00 W
    
```

The Motor Calibration screen is used when a motor is replaced or the control firmware is updated. Move the cursor to the correct option and press the SEL button to calibrate the motor to the control.

## I. Clear Log Data

```
Clear Log Data

This will clear the error log
and the statistics.
Are you sure
you want to do that
_ No
_ Yes
```

The Clear Log Data screen will clear all the errors and statistics in memory.

## J. Restore Factory Defaults / Restore Motor Table Defaults

```
Restore Factory Settings

This will reset all machine
settings to the original
factory configurations. Are
you sure you want to do that
_ No
_ Yes
```

```
Restore Motor Table Defaults

This will reset all motor
tables to the original
factory configurations. Are
you sure you want to do that
_ No
_ Yes
```

The Restore Factory Defaults and Restore Motor Table defaults screens allow you to restore the control to the factory configurations.

## K. Restore Unit Configuration

```
Reset Unit Configuration

This will reset the unit type
and motor types.

Are you sure you want to do that
_ No
_ Yes
```

The Restore Unit Configuration screen allows you to change the motor type default. See section 4.8 for details.

## 4.7 ERRORS & STATISTICS SCREENS

The Errors & Statistics menu gives the Technician access to machine statistics and error history.

```
Errors and Statistics

_ Machine Statistics
_ Error History
```

### A. Machine Statistics (1 of 10)

```
Machine Statistics (1 of 10)
Cylinder                               Right
Time in Serve Mode                     0000 hr
    Last 24hrs                          0000 min
    Last 7days                          0000 hr
Time in Off Mode                        0000 hr
    Last 24hrs                          0000 min
    Last 7days                          0000 hr
```

The Machine Statistics screen 1 of 10 shows the time in serve mode and time in sleep mode. The screen shows a running total, the total for the previous day and the total for the previous week for both statistics.

### B. Machine Statistics (2 of 10)

Machine Statistics (2 of 10)	
Cylinder	Right
Total Low Mix Run	0000 hr
Last 24hrs	0000 min
Last 7days	0000 hr

The Machine Statistics screen 2 of 10 shows the low mix running time. This is the total time, including serve mode and sleep mode, that the freezing cylinder was operating with a low mix error. The screen shows a running total, the total for the previous day and the total for the previous week.

### C. Machine Statistics (3 of 10)

Machine Statistics (3 of 10)	
Cylinder	Right
Last Clean Cycle	00/00/00 00:00:00 AM
Last Clean Total Time	0000 min

The Machine Statistics screen 3 of 10 provides the time and date that the freezing cylinder was last cleaned. This value is recorded when the Clean button is pressed on the touchpad. The screen also shows how long the most recent clean mode lasted.

### D. Machine Statistics (4 of 10)

Machine Statistics (4 of 10)	
Cylinder	Right
Spigot Open Total	0000 min
Last 24hrs	0000 min
Last 7days	0000 min
Spigot Total Cycles	0000
Average Spigot Open	0000 sec

The Machine Statistics screen 4 of 10 shows the total time that the spigot has been open during serve mode. The screen shows a running total, the total for the previous day and the total for the previous week. The screen also shows the total times that the spigot has been opened.

### E. Machine Statistics (5 of 10)

Machine Statistics (5 of 10)	
Cylinder	Right
Estimated Serve Amount	0000 gal
Last 24hrs	0000 gal
Last 7days	0000 gal
Last Serve Reset	00/00/00 00:00:00 AM
_ Reset Serve Amount	

The Machine Statistics screen 5 of 10 gives the estimated serve amount of the freezing cylinder based on the time the spigot is open during serve mode. The estimation is also calculated for the previous day and the previous week. The screen gives an option to reset the serve amount and shows when the last reset was done.

### F. Machine Statistics (6 of 10)

Machine Statistics (6 of 10)	
Cylinder	Right
Compressor Run Time	0000 hr
Compressor Cycles	0000
Last Compressor Reset	00/00/00 00:00:00
_ Reset Compressor Time	

The Machine Statistics screen 6 of 10 shows the total run time for the compressor and counts the total cycles. There is an option to reset the timer and the screen shows when the last reset was done. The reset should be used if the compressor is changed.

### G. Machine Statistics (7 of 10)

Machine Statistics (7 of 10)	
Cylinder	Right
Motor Run Time	0000 hr
Motor Cycles	0000
Last Motor Reset	00/00/00 00:00:00 AM
_ Reset Motor Time	

The Machine Statistics screen 7 of 10 shows the total run time for the drive motor and counts the total cycles. There is an option to reset the timer and the screen shows when the last reset was done. The reset should be used if the drive motor is changed.

## H. Machine Statistics (8 of 10)

Machine Statistics (8 of 10)	
Cylinder	Right
Pump Run Time	0000 hr
Pump Cycles	0000
Last Pump Reset	00/00/00
	00:00:00 AM
_ Reset Pump Time	

The Machine Statistics screen 8 of 10 shows the total run time for the pump and counts the total cycles. There is an option to reset the timer and the screen shows when the last reset was done. The reset should be used if the pump is changed.

## I. Machine Statistics (9 of 10)

Machine Statistics (9 of 10)	
Cylinder	Right
Current Hose Usage	0000 hr
Hose Service Limit	100 hr
Last Hose Reposition	00/00/00
	00:00:00 AM
_ Reset Hose Service Time	

The Machine Statistics screen 9 of 10 shows the amount of time the pump hose has been in use and when the last reposition was completed. There is also an option to reset the hose timer.

## J. Machine Statistics (10 of 10)

Machine Statistics (10 of 10)	
Last Unit Power Up	00/00/00
	00:00:00
Avg Power KWH/Day	0 Watts

The Machine Statistics screen 10 of 10 shows when the machine was last powered on. The screen also gives an average power consumption per day.

## K. Error History

Error History 25 of 25	
Type	Cylinder Sensor
Date	00/00/00 00:00:00 AM
Cylinder	Right
_ Status At Time of Error	
_ Help	

The Error History screen shows the last error that occurred. The screen shows the type of error, the time and date and the cylinder that had the error. Up to 25 errors are stored. Press the up or down arrow to scroll through the errors. Select the Status at Time of Error option to view data for the time the error occurred. The Help option explains the error and provides quick troubleshooting tips.

## L. Status at Time of Error

Status at Time of Error	
Operating Mode	Off
Mix Levels	Full Level
Consistency	000.00
Input Voltage	000.0V
Motor Amps	00.000A
Ambient Temp	-000.0°F
Cylinder Temp	-000.0°F

The Status at Time of Error screen gives data for the time the error occurred.

## 4.8 UPDATING FIRMWARE

Before starting, make sure there is liquid mix or water in the freezing cylinder. The calibration steps should not be completed with frozen product in the freezing cylinders.

Firmware is contained in a .rom file which can be downloaded from the extranet website or sent via email. Download the .rom file onto the top level of a USB drive (don't put the file in a folder and don't change the name of the file) and follow the instructions below.

- A. Unplug the machine from electrical power.

### NOTE

*On a dual power supply machine, unplug both sides.*

- B. Connect the USB flash drive to the port on the machine. Depending on the model, the USB port will be located:
  1. On the side of the machine. Remove the plug.
  2. Behind the header panel. Remove the panel and locate the USB connector on the display module.
- E. Connect power to the machine. On a dual power supply machine, only the left side needs to be connected.
- F. The display should say "Stoelting Foodservice Equipment" in a large font and the new firmware version will be displayed at the bottom.

**NOTE**

*If the display does not show the "Stoelting Foodservice Equipment" text, make sure the .rom file is in the top level of the USB flash drive. The .rom file cannot be in any folders within the flash drive.*

- G. From the Current Status screen, press the left arrow button to get to the passcode entry screen.
- H. Enter the technician password to the control by pressing the right arrow, SET, then the SEL button.
- I. Navigate to the Utilities menu and select the Next Utilities Menu.
- J. Go to the Reset Unit Configuration option and press the SEL button.
- K. On the Reset Unit Configuration screen select the Yes option and press the SEL button.
- L. Confirm the control settings are the same as the values in the table below:

Machine	Machine Type	Motor Type
F231-18	2	2
F231-38	2	2
F231-109	2	3
F231-309	2	3

**Machine & Motor Types**

- M. Scroll the cursor down to the Accept option and press the SEL button. The screen will read "Restoring EEPROM". This process takes about three minutes.
- N. Once the control has completed this step, it will automatically restart.
- O. Enter the technician password to the control by pressing the right arrow, SET, then the SEL button.
- P. Navigate to the Utilities menu and select the Next Utilities Menu.

- Q. Go to the Motor Zero Load Calibration option and press the SEL button.

**NOTE**

*Calibration must be done with water or liquid mix in the freezing cylinder. Do not try to calibrate with frozen mix in the freezing cylinder.*

- R. Press the SEL button to calibrate the motors for both freezing cylinders.

**NOTE**

*If the motors do not start, cycle the power and try again.*

- S. Press the left arrow to exit the Utilities menu and go the Main Menu screen.
- T. Go to the Modify Settings screen, scroll to the User Preferences option and press SEL at the Service Contact Information screen.
- U. Scroll to the serial number and press the SET button. Enter the serial number for the machine by scrolling through the numbers. The serial number is found on the information plate located on the side or back of the machine. If the last digit is a blank, scroll past the "z" for the blank space.

**4.9 DRIVE BELT TENSION ADJUSTMENT**

To check belt tension, refer to Figure 4-1 and follow the steps below:

**! WARNING**

**Hazardous voltage**

Make sure the machine is off when disassembling for servicing. The machine must be disconnected from electrical supply before removing any access panel. Failure to disconnect power before servicing could result in death or serious injury.

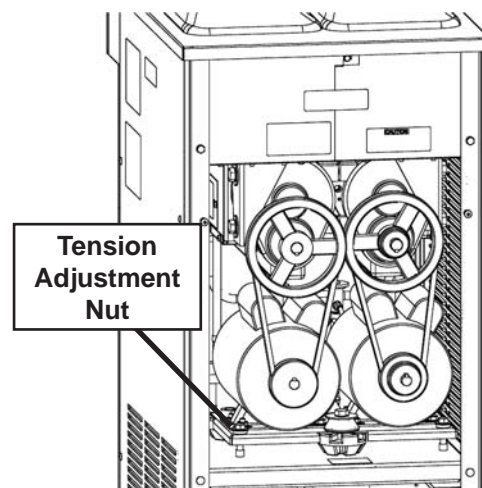

**Figure 4-1 Belt Tension Adjustment**

- A. Remove the back panel.
- B. Use a Burroughs Belt Tension Gauge to set the tension for the drive belt. Set the belt tension to 40-45 lbs.
- C. If an adjustment is necessary, loosen the four motor plate retaining nuts, adjust belt tension then retighten the four nuts.
- D. Using a straightedge, check that the drive motor pulley is aligned with the speed reducer pulley. Align the pulley if necessary.

**NOTE**

*Belt life will be increased if new drive belts are tightened after two or three weeks of operation.*

**4.10 CONDENSER CLEANING (AIR-COOLED MACHINES)**

The F231 has an air-cooled or water-cooled condenser.

The air-cooled condenser is a copper tube and aluminum fin type. Condensing is totally dependent upon airflow. A plugged condenser, or restrictions in the louvered panel will restrict airflow. This will lower the capacity of the system and damage the compressor. The condenser must be kept clean of dirt and grease. The machine must have a minimum of 3" (7.6 cm) of ventilation on the sides of the unit for free flow of air. Make sure the machine is not pulling over 100° F (37° C) air from other equipment in the area.

The water-cooled condenser is a tube and shell type. The condenser needs a cool, clean supply of water to properly cool the machine, inlet and discharge lines must be 3/8" I.D. minimum.

The air-cooled condenser requires periodic cleaning. To clean, refer to the following procedures.

- A. Visually inspect the condenser for dirt.
- B. If the condenser is dirty, place a wet towel over the condenser.
- C. Using compressed air or CO<sub>2</sub> tank, blow out the dirt from the back of the condenser. Most of the dirt will cling to the wet towel.
- D. An alternative method is to clean with a condenser brush and vacuum.

**NOTE**

*If the condenser is not kept clean, refrigeration efficiency will be lost.*

**4.11 PREVENTATIVE MAINTENANCE**

It is recommended that a preventative maintenance schedule be followed to keep the machine clean and operating properly. The following steps are suggested as a preventative maintenance guide.

The United States department of agriculture and the food and drug administration require that lubricants used in food zones be certified for this use. Use lubricants only in accordance with the manufacturer's instructions.

- A. Daily checks
  - Check for any unusual noise or condition and repair immediately.
- B. Monthly checks
  - Check the condenser for dirt and clean if necessary.
- C. Quarterly Checks
  - Check drive belts for wear and tighten belts if necessary.

**4.12 EXTENDED STORAGE**

Refer to the following steps for storage of the machine over any long period of shutdown time:

- A. Clean all the parts that come in contact with mix thoroughly with a warm detergent water. Rinse in clear water and dry all parts. Do not sanitize.

**NOTE**

*Do not let cleaning solution stand in the freezing cylinder or hopper during the shutdown period.*

- B. Remove, disassemble, and clean the front door, and auger shaft. Leave disassembled during the shutdown period.
- C. Place the auger flights and auger support bushing in a plastic bag with a moist paper towel. This will prevent them from becoming brittle if exposed to dry air over an extended period of time (over 30 days).



## SECTION 5 REFRIGERATION SYSTEM

### 5.1 REFRIGERATION SYSTEM

The F231 refrigeration systems have two functions:

Medium-Temperature - Maintaining mix temperature in the hopper.

Low-Temperature - Producing and maintaining high quality product in the freezing cylinders.

The system is designed for efficient use with R404A refrigerant. The proper charge is indicated on the information plate.

### 5.2 REFRIGERANT RECOVERY AND EVACUATION

Refer to the following procedures to properly recover and evacuate the refrigeration system. Do not purge refrigerant into the atmosphere.

### NOTE

*For qualified service personnel only. Anybody working with refrigerants must be certified as a Technician TYPE I as required by 40 CFR 82 Subpart F and hold all State and/or local refrigerant handling certifications. In addition, all handling, storage, and disposal of refrigerants must be in accordance with Environmental Protection Agency (EPA) guidelines and standards and all State and local guidelines and standards.*



### WARNING

#### Hazardous voltage

Make sure the machine is off when disassembling for servicing. The machine must be disconnected from electrical supply before removing any access panel. Failure to disconnect power before servicing could result in death or serious injury.

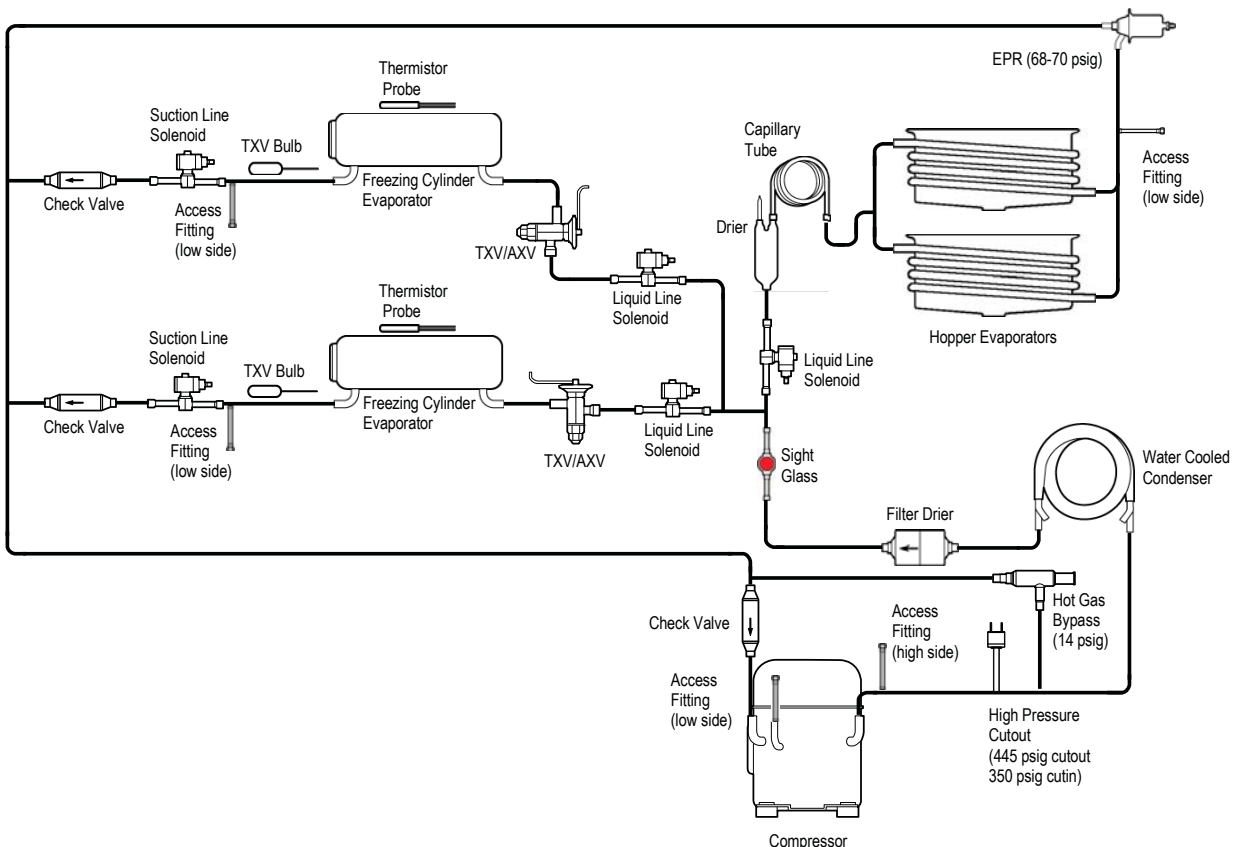

**Figure 5-1 Water Cooled Refrigeration System**

## A. REFRIGERANT RECOVERY

1. Disconnect the machine from electrical supply before removing any panels for servicing.
2. Remove all panels.
3. Connect the recovery unit to the suction and discharge service valves of the compressor.
4. Connect power to the machine.
5. Turn the machine on by pressing the Main Power Off/On button.
6. Press the right arrow, SET, then the SEL button to access the technician level on the control.
7. Activate the Liquid Solenoid and the Refer Solenoid on the left side and right side. Activating the solenoids is done through the Left Output Control and Right Output Control menus which are located under Utilities in the Testing and Manual Operation screen. Refer to Section 4 for details.

CAUTION
The solenoid valves must be energized to allow all refrigerant to be recovered and to prevent injury when brazing.

8. Operate the recovery unit per manufacturer's instructions
9. After recovery is complete, deactivate the solenoids by exiting the Testing and Manual Operation screens.

## B. EVACUATING THE REFRIGERATION SYSTEM

1. Close any open ports in the refrigeration system.
2. Connect a vacuum gauge to one of the Schrader valves next to an evaporator.
3. Connect the evacuation unit to the suction and discharge service valves of the compressor.
4. Connect power to the machine.
5. Turn the machine on by pressing the Main Power Off/On button.
6. Press the right arrow, SET, then the SEL button to access the technician level on the control.
7. Activate the Liquid Solenoid and the Refer Solenoid on the left side and right side. Activating the solenoids is done through the Left Output Control and Right Output Control menus which are located under Utilities in the Testing and Manual Operation screen. Refer to Section 4 for details.

8. Evacuate the system until the gauge reads 300 microns of mercury (300 $\mu$  Hg) for 5 continuous minutes.
10. If the system will not maintain a standing vacuum test with the vacuum pump off (gauge increases towards atmosphere), find the leak, fix it, and evacuate again.
11. After evacuating is complete, deactivate the solenoids by exiting the Testing and Manual Operation screens.

## 5.3 REFRIGERANT CHARGING

Refer to the following procedures to properly charge the refrigeration system. Stoelting recommends liquid refrigerant charging.

### NOTE

*For qualified service personnel only. Anybody working with refrigerants must be certified as a Technician TYPE I as required by 40 CFR 82 Subpart F and hold all State and/or local refrigerant handling certifications. In addition, all handling, storage, and disposal of refrigerants must be in accordance with Environmental Protection Agency (EPA) guidelines and standards and all State and local guidelines and standards.*

- A. Ensure the electrical supply has been removed before continuing.
- B. If the system has been opened or if there was a leak, refer to Section 5.2 - Refrigerant Recovery and Evacuation to evacuate the system prior to charging.
- C. Refer to machine's information plate for total charge requirements.

### NOTE

*The refrigeration systems of F231 is critically charged. Be sure to charge the system to the weight listed on the machine's information plate.*

- D. For liquid refrigerant charging, connect refrigerant cylinder to the discharge Schrader valve of the compressor.
- E. Energize all five solenoid valves. There are three liquid line solenoids and two suction line solenoids.
- F. Add the proper amount of refrigerant according to the machine's information plate.

## 5.4 COMPRESSOR

The F231 has a hermetic reciprocating compressor (Refer to Figure 5-2).



Figure 5-2 Compressor

### A. WINDING TEST

To test the compressor motor windings for possible problems, perform the following steps:

- A. Disconnect the machine from electrical supply



### WARNING

#### Hazardous voltage

Make sure the machine is off when disassembling for servicing. The machine must be disconnected from electrical supply before removing any access panel. Failure to disconnect power before servicing could result in death or serious injury.

before removing any panels for servicing.

- B. Remove the front panel.
- C. Remove the protective cover from the compressor terminals. Disconnect the three terminals; C (common), R (run), and S (start).
- D. Connect an ohmmeter to the C and R terminals on the compressor. Resistance through the run winding should be  $1.16\Omega \pm 10\%$ .
- E. Connect an ohmmeter to the C and S terminals on the compressor. Resistance through the start winding should be  $3.10\Omega \pm 10\%$ .

- F. To check if windings are shorted to ground, connect one ohmmeter lead to a bare metal part on the compressor (such as any copper line leading to or from the compressor) and check terminals C, R, and S.

### NOTE

*The compressor is equipped with an internal overload protector. If the compressor is warm and ohmmeter readings indicate an open winding, allow up to one hour for overload to reset.*

### B. COMPRESSOR REMOVAL

- A. Disconnect the machine from electrical supply before removing any panels for servicing.
- B. Remove the front panel.
- C. Remove the protective cover from the compressor terminals and disconnect the wires.
- D. Recover refrigerant charge per the instructions in Section 5.2.
- E. Leave the suction and discharge ports open to prevent pressure buildup during compressor removal.
- F. Remove six inches of insulating tubing on the suction line going to the compressor and unsweat the suction and discharge line from the compressor.
- G. Remove the four nuts and washers from the base of the compressor.
- H. Remove the compressor through the front of the machine.
- I. Remove the four rubber compressor mounts from the compressor.
- J. Crimp and braze all open ports of the old compressor.

### NOTE

*A compressor returned to Stoelting with any open ports will void the warranty. ALWAYS crimp and braze ports on a compressor that has been removed.*

### C. COMPRESSOR INSTALLATION

- A. Make sure the machine is disconnected from the electrical supply before removing any panels for servicing.
- B. Install the four rubber mounts on the compressor.
- C. Install the compressor into the machine, fitting the base over the four bolt holes.
- D. Install the four washers and nuts onto the bolts and tighten securely.

- E. Remove all tubing plugs from the replacement compressor.

**NOTE**

*The compressor plugs protect the compressor from moisture in the air. Do not remove the plugs until you are ready to install. The compressor must not be opened to the atmosphere for more than 10 minutes.*

- F. Leave the suction and discharge ports open to prevent pressure buildup. Braze the suction and discharge line to the compressor.
- G. Connect the wires to the compressor terminals.
- H. Replace the drier per the instructions in Section 5.9.
- I. Evacuate the system per the instructions in Section 5.2
- J. Recharge the system per the instructions in Section 5.3.
- K. Replace the insulating tubing on the suction line.

**5.5 CONDENSER**

The F231 comes with either an air-cooled or a water-cooled condenser. The capacity of the machine is directly related to keeping the condenser clean and free of debris.

The air-cooled condenser is a copper tube and aluminum fin type. The machine must have a minimum of 3" of clearance on both sides for proper air flow.

The water-cooled condenser is a tube and shell type. This condenser requires cool, clean water to function properly. Inlet and discharge lines must be 3/8" ID minimum.

**CONDENSER TESTING**

The condenser can be checked for leaks using the bubble test or using a leak detector.

**5.6 VALVES**

**A. THERMOSTATIC EXPANSION VALVE (TXV)**

The Thermostatic Expansion Valve (TXV) is used to meter the refrigerant to the freezing cylinder evaporator. It does so by maintaining constant superheat at the exit of the evaporator. The self-regulating TXV is preset by the manufacturer and adjustment is not recommended. Figure 5-3.

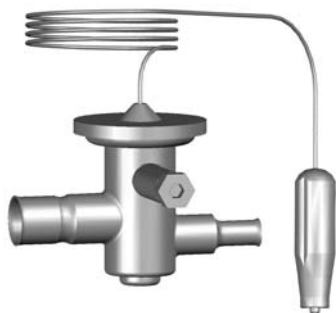

**Figure 5-3 TXV**

**TXV TESTING & ADJUSTMENT**

**NOTE**

*The bulb has an indent which must be positioned against the tubing. Good contact between the bulb and the suction line is necessary for proper operation of the valve. The bulb must also be well insulated.*

- A. Connect a gauge to the Schrader valve on the suction line.
- B. Connect a thermocouple to the suction line next to the evaporator.
- C. Immediately before the refrigeration cycle ends, the gauge should read between 18-22 psig. The superheat should be 7-10°F.
- D. If the pressure reading is higher than expected and the superheat is low, check to see if there is an overcharge of refrigerant.
- E. If the pressure reading is lower than expected and the superheat is high, check to see if there is a low refrigerant charge or if there is a restriction in the system.

**NOTE**

*The TXV is the LAST component to adjust in the refrigeration system.*

- F. The TXV can be adjusted after the steps above are completed. When adjusting, do not turn the valve over 1/4 turn (90°). Turn the valve stem clockwise to increase the superheat or counterclockwise to decrease the superheat.

**TXV REMOVAL**

- A. Disconnect the machine from electrical supply before removing any panels for servicing. Remove the front panel.
- B. Recover refrigerant charge per instructions in Section 5.2.
- C. Leave the suction and discharge ports open to prevent pressure buildup during TXV removal.
- D. Remove any insulation from the TXV and immediate surrounding lines.
- E. Apply a heat sink (wet cloth) to the valve dome (Figure 5-4).
- F. Unsweat the TXV and remove.



**Figure 5-4 TXV Removal**

## TXV REPLACEMENT

To replace the TXV, perform the following procedures:

- A. Position the TXV, with a heat sink, into the system.
- B. With the suction and discharge ports open, braze the TXV into the system.
- C. Remove the heat sink from the TXV.
- E. Replace insulation to the TXV and surrounding lines.
- F. Replace the drier per the instructions in Section 5.9.
- G. Evacuate the system per the instructions in Section 5.2.
- H. Recharge the system per the instructions in Section 5.3.

## B. AUTOMATIC EXPANSION VALVE (AXV)

The Automatic Expansion Valve (AXV) is in OT2, YG2 and YG2ME models and is used to meter the refrigerant to the freezing cylinder evaporator. It does so by maintaining a constant pressure in the evaporator. The self-regulating AXV is preset by the manufacturer and adjustment is not recommended. Figure 5-5.

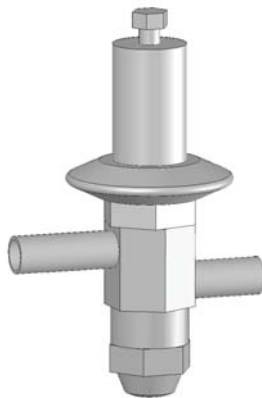

Figure 5-5 AXV

## AXV TESTING & ADJUSTMENT

When testing an AXV, isolate the evaporator from the other evaporators:

To test the left side AXV, turn the right side freezing cylinder OFF and turn the Aux Solenoid off in the control under the Testing and Manual Ops screen.

If checking the right side AXV, turn the left side freezing cylinder OFF and turn the Aux Solenoid off in the control under the Testing and Manual Ops screen..

- A. Connect a gauge to the Schrader valve on the suction line next to the evaporator.
- B. Connect a thermocouple to the suction line next to the evaporator.

- C. Immediately before the refrigeration cycle ends, the gauge should read the following:  
OT2 Models: 22-24 psig  
YG2 Models: 23-25 psig  
YG2ME Models: 18-20 psig  
This reading is based on a full load in the freezing cylinder.
- D. If the pressure reading is higher than expected, check to see if there is an overcharge of refrigerant.
- E. If the pressure reading is lower than expected, check to see if there is a low refrigerant charge or if there is a restriction in the system.

### NOTE

*The AXV is the LAST component to adjust in the refrigeration system.*

- F. The AXV can be adjusted after the steps above are completed. When adjusting, do not turn the valve over 1/4 turn (90°). Turn the valve stem clockwise to decrease the evaporator pressure or counterclockwise to increase the evaporator pressure.

## AXV REMOVAL

- A. Disconnect the machine from electrical supply before removing any panels for servicing. Remove the side panels.
- B. Recover refrigerant charge per instructions in Section 5.2.
- C. Leave the suction and discharge ports open to prevent pressure buildup during AXV removal.
- D. Remove any insulation from the AXV and immediate surrounding lines.
- E. Apply a heat sink (wet cloth) to the valve dome.
- F. Unswear the AXV and remove.

## AXV REPLACEMENT

To replace the AXV, perform the following procedures:

- A. Position the AXV, with a heat sink, into the system.
- B. With the suction and discharge ports open, braze the AXV into the system.
- C. Remove the heat sink from the AXV.
- E. Replace insulation to the AXV and surrounding lines.
- F. Replace the drier per the instructions in Section 5.9.
- G. Evacuate the system per the instructions in Section 5.2.
- H. Recharge the system per the instructions in Section 5.3.

### C. CHECK VALVE

The machine has 3 magnetic check valves (Refer to Figure 5-6). Each valve is positioned in the suction line and prevents backflow of refrigerant into the evaporator. If there is reversed flow, the product in the freezing cylinder softens and liquid refrigerant can flood into the compressor on startup.

If a check valve needs to be replaced, use a heat sink (wet cloth) when installing the new valve to prevent damage.



Figure 5-6 Check Valve

### D. HIGH PRESSURE CUTOUT

The high pressure cutout stops the compressor if the discharge pressure reaches the cutout, 445 psig for the freezing cylinders. It is an automatic reset when the pressure drops below 350 psig.



Figure 5-7 High Pressure Cutout

### HIGH PRESSURE CUTOUT TEST

- A. Connect a gauge to the Schrader valve on the discharge line.
- B. Disconnect cooling:  
In a water-cooled machine, shut off the water supply.  
In an air-cooled machine, shut off the fan motor in the IntelliTec2™ control. Refer to Section 4.6 for details.

- C. High pressure cutout should trip when pressure reaches 445 psig  $\pm$ 9.

### HIGH PRESSURE CUTOUT REMOVAL

- A. Remove the left side panel.
- B. Recover refrigerant charge per instructions in Section 5.2.
- C. Leave the suction and discharge ports open to prevent pressure buildup during removal.
- D. Unsweat capillary tube from suction line.
- E. Disconnect terminals from high pressure cutout.

### HIGH PRESSURE CUTOUT REPLACEMENT

- A. With the suction and discharge ports open, braze the capillary tube to the discharge line.
- C. Replace the drier per the instructions in Section 5.9.
- D. Braze bulb into place on suction line.
- E. Evacuate the system per the instructions in Section 5.2.
- F. Recharge the system per the instructions in Section 5.3.
- G. Connect the terminals to the high pressure cutout.
- H. Attach the high pressure cutout using the two screws with star washers.

### E. HOT GAS BYPASS

The hot gas bypass valve is installed parallel to the compressor and helps to regulate the compressor temperature (Refer to Figure 5-8). When the cab evaporator is the only part of the system requiring refrigerant, the bypass valve will allow discharge gas to bypass into the suction line to prevent liquid refrigerant from entering the compressor.

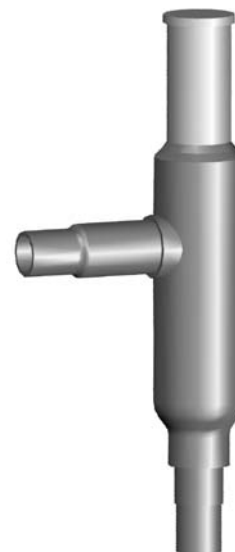

Figure 5-8 Hot Gas Bypass

## HOT GAS BYPASS ADJUSTMENT

Adjustment to the hot gas bypass must be made when the hopper refrigeration is the only part of the system running.

### NOTE

*Before adjusting the hot gas bypass, check the EPR valve and adjust if necessary.*

- A. Turn the machine off by pressing the Main Power On/Off button.
- B. Connect a gauge to the Schrader valve on the suction line next to the compressor.
- C. Wait until the gauge stops moving.
- D. Unscrew the seal cap from the top of the valve.
- E. Using a 5/16" Allen wrench, adjust the valve counterclockwise to decrease pressure and clockwise to increase pressure.

### NOTE

*Each 360° turn will change the pressure about 6 psig.*

- F. Adjust the hot gas bypass valve to 14 psig  $\pm$ 1.
- G. Wait 2 minutes to ensure pressure remains stable.
- H. Hand-tighten seal cap to valve.

## HOT GAS BYPASS REMOVAL

- A. Remove the left side panel.
- B. Recover refrigerant charge per instructions in Section 5.2.
- C. Remove insulation around hot gas bypass and tubing.
- D. Leave the suction and discharge ports open to prevent pressure buildup during hot gas bypass removal.
- E. Apply a heat sink (wet cloth) to the hot gas bypass.
- F. Unsweat the hot gas bypass and remove.

## HOT GAS BYPASS REPLACEMENT

To replace the hot gas bypass, perform the following procedures:

- A. Apply a heat sink (wet cloth) to the hot gas bypass.
- B. With an open port, braze the hot gas bypass into the system.
- C. Remove the heat sink from the hot gas bypass.
- D. Replace the filter drier. Refer to Section 5.8 for details.
- E. Evacuate and recharge system per instructions in Section 5.2.

## F. EVAPORATOR PRESSURE REGULATOR (EPR)

There is one EPR in the refrigeration system (Refer to Figure 5-9). It is located on the suction line of the hopper evaporators and regulates evaporator refrigerant pressure.

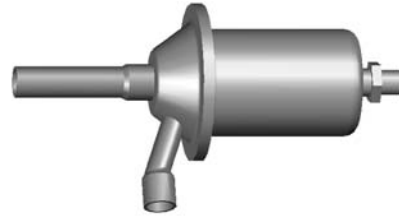

Figure 5-9 EPR Valve

## EPR TEST AND ADJUSTMENT

Adjustment to the EPR must be made when the hopper refrigeration is the only part of the system running

- A. Turn the machine off by pressing the Main Power Off/On button.
- B. Connect a gauge to the Schrader valve on the suction line between the hopper evaporators and the EPR.
- C. Press the Main Power OFF/ON button to turn the machine power on. Listen for the compressor to start a cycle for the hopper.
- D. If the gauge does not read 69  $\pm$ 1 then adjustment is needed.
- F. Remove the plastic cap and loosen the locknut on the EPR. Using a small screwdriver, turn the adjustment screw counterclockwise 1/2 turn, then adjust as necessary. Turn the valve stem clockwise for higher pressure or counterclockwise for lower pressure.
- G. Allow the system to stabilize for 5 minutes to ensure pressure remains stable.

## EPR REMOVAL

- A. Remove the left side panel and front panel.
- B. Recover refrigerant charge per instructions in Section 5.2.
- C. Leave the suction and discharge ports open to prevent pressure buildup during EPR removal.
- D. Unsweat the EPR and remove.

## EPR REPLACEMENT

To replace the EPR, perform the following procedures:

- A. Apply a heat sink (wet cloth) to the EPR.
- B. With an open port, braze the EPR into the system.
- C. Remove the heat sink from the hot gas bypass.
- D. Replace the filter drier. Refer to Section 5.8 for details.
- E. Evacuate and recharge system per instructions in Section 5.2.

## G. WATER VALVE (WATER COOLED MODELS ONLY)

The water valve monitors refrigerant pressure and opens on an increase of pressure. The opening point pressure is the refrigerant pressure required to lift the valve disc off the valve seat. (Figure 5-10)

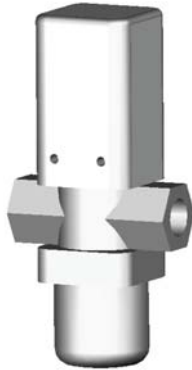

Figure 5-10 Water Valve

## WATER VALVE ADJUSTMENT

- A. Remove the right side panel.
- B. Connect a gauge to the compressor discharge Schrader valve.
- C. Connect the machine to the electrical supply, start the refrigeration cycle, and read the pressure.
- D. The proper gauge reading should be 225-235 psig. The exit water temperature should be 95-107°F.
- E. If the water temperature and high side pressure are too low, the opening point pressure should be increased to slow the water flow. Turn the adjustment screw counterclockwise.
- F. If the water temperature and high side pressure are too high, the opening point pressure should be decreased to increase the flow of water. Turn the adjustment screw clockwise.

## WATER VALVE REMOVAL

The water valve is connected to the refrigeration system by capillary tube brazed to the discharge line.

- A. Turn off and disconnect the water supply. Blow out the water lines with compressed air or CO<sub>2</sub>.
- B. Recover refrigerant charge per instructions in Section 5.2.
- C. Leave the suction and discharge ports open to prevent pressure buildup during water valve removal.
- D. Unsweat the capillary tube from the discharge line.
- E. Remove the clamps from the water lines at the valve.
- F. Remove the two screws holding the water valve to the frame and remove the valve.

## WATER VALVE REPLACEMENT

To replace the water valve, perform the following procedures:

- A. Position the water valve and attach to the frame using the two screws.
- B. Install the water lines onto the valve with hose clamps.
- C. Leave the suction and discharge ports open to prevent pressure buildup during water valve installation.
- D. Braze the capillary tube into the system.
- E. Connect the water supply line and turn on the water supply.
- F. Check for leaks in the water lines. If there are no leaks, turn off the water supply.
- G. Replace the filter drier. Refer to Section 5.8 for details.
- H. Evacuate and recharge system per instructions in Section 5.2.
- I. Turn on the water and check for leaks in the water lines with the refrigeration system running.
- J. Adjust the valve as necessary.

## 5.7 SOLENOID

Solenoid valves are installed on the liquid and suction lines of each freezing cylinder evaporator and on the liquid line of the hopper evaporators (Refer to Figure 5-11 and Figure 5-12). A solenoid valve has a magnetic coil that, when energized, lifts a plunger and allows refrigerant to flow. The solenoids are activated by the IntelliTec2™ control and determine which evaporator receives refrigeration.

The suction line solenoid prevents refrigerant flow in the evaporator when the suction pressure drops due to the operation of the other evaporators in the system.

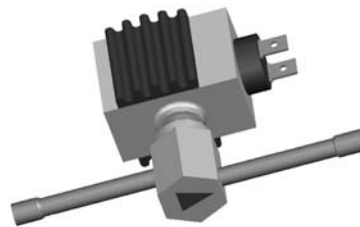

Figure 5-11 Liquid Line Solenoid Valve



Figure 5-12 Suction Line Solenoid Valve

## ACTIVATING A SOLENOID

To open a solenoid, follow these steps:

- A. Turn the machine on by pressing the Main Power Off/On button.
- B. Press the right arrow, SET, then the SEL button to access the technician level on the control.
- C. Navigate to the Left Output Control or Right Output Control menu which is located under Utilities in the Testing and Manual Operation screen. Refer to Section 4 for details.
- D. Activate the solenoid by moving the cursor to the Liquid Solenoid option and pressing the SET button.

### NOTE

*Any energized component will deenergize after leaving the Testing and Manual Operations menu.*

## SUCTION LINE SOLENOID TESTING

To check for leaking valve seats, follow the procedure outlined below. The liquid line solenoid must remain open for this test.

### NOTE

*Machine barrels must NOT contain frozen product for this test.*

- A. Turn the machine off by pressing the Main Power On/Off button.
- B. Attach a gauge to the Schrader valve located after the evaporator of the side being tested.
- C. Turn the machine on by pressing the Main Power Off/On button.
- D. Turn the opposite side Freezing Cylinder on by pressing the On/Off Left or On/Off Right button.

### NOTE

*If checking the solenoid on the left side, press the On/Off Right button. For the right side, press the On/Off Left button.*

- E. Start a freezing cycle of the opposite side by pressing the Push To Freeze button or by pulling the spigot handle.
- F. If the pressure drops more than 3 psi in 30 seconds on the side being tested, the suction line solenoid valve seat leaks and should be replaced. Repeat the procedure for the other side.

## LIQUID LINE SOLENOID TESTING

The following test will check if a liquid line solenoid has a leaking valve seat. The power to the solenoid is disconnected and refrigerant flow is monitored through the system. If the valve seat does not leak, the suction pressure during the test will be low.

- A. Attach a gauge to the Schrader valve on the suction line.

- B. Turn the machine on by pressing the Main Power Off/On button.
- C. Press the right arrow, SET, then the SEL button to access the technician level on the control.
- D. Navigate to the Left Output Control or Right Output Control menu which is located under Utilities in the Testing and Manual Operation screen. Refer to Section 4 for details.
- E. Activate the compressor by moving the cursor to the compressor option and pressing the SET button.
- F. The gauge should read well below 21 psig after 1 minute.
- G. A leaking valve seat may also show frost on the liquid line tubing just past the solenoid and before the evaporator.

## SOLENOID MAGNETIC COIL REMOVAL

- A. Remove the side panel.
- B. Disconnect the electrical wires.
- C. Remove the retainer screw from the top of the solenoid and pull the magnetic coil off.

## SOLENOID MAGNETIC COIL INSTALLATION

To replace the magnetic coil, perform the following procedures:

- A. Connect the two electrical wires to the magnetic coil.
- B. Push the coil on to the solenoid valve stem.
- C. Make sure there isn't any foam insulation between the valve coil and valve body. Trim any excess insulation.
- D. Install retainer screw onto top of coil.

## SOLENOID VALVE REMOVAL

- A. Identify and disconnect the two wires from the solenoid coil.
- B. Remove the retainer holding the coil to the solenoid body and remove the coil.
- C. Recover refrigerant charge per instructions in Section 5.2.
- D. Remove insulation around valve and attached refrigeration lines.
- E. Apply heat sinks (wet cloth) to the insulated refrigerant lines near the valve.
- F. Leave a port open to prevent pressure buildup during solenoid removal
- G. Unswear the solenoid and remove.

## SOLENOID VALVE REPLACEMENT

To replace the solenoid, perform the following procedures:

- A. Position the new solenoid with the arrow pointing toward the direction of refrigerant flow.

- B. Apply a heat sink (wet cloth) to the solenoid valve.
- C. With the suction and discharge ports open, braze the solenoid into the system.
- D. Remove the heat sink from the valve.
- E. Replace insulation around valve.
- F. Replace the filter drier. Refer to Section 5.8 for details.
- G. Evacuate and recharge system per instructions in Section 5.2.

### 5.8 FILTER DRIER

The filter drier must be replaced every time the refrigeration system is opened for service. A new filter drier improves operation of the entire refrigeration system by stopping the circulation of moisture and by removing harmful contaminants (Refer to Figure 5-13).



**Figure 5-13 Filter Drier**

#### FILTER DRIER REMOVAL

- A. Recover refrigerant charge per instructions in Section 5.2.
- B. Cut the refrigeration line as close to the filter drier as possible and remove drier.
- C. Cap the ends of the drier using the plugs from the new drier.

#### NOTE

*The drier must be capped to prevent moisture from the environment*

#### FILTER DRIER REPLACEMENT

- A. Position the filter drier so the arrow is pointing toward the direction of refrigerant flow (pointing away from the condenser).
- B. Apply a heat sink (wet cloth) to the filter drier.
- C. With the suction and discharge ports open, braze the filter drier into the system.
- D. Evacuate the system per instructions in Section 5.2.
- E. Recharge the system per instructions in Section 5.3.

### 5.9 CAPILLARY TUBE

The capillary tube meters refrigerant flow in the mix line evaporator (Refer to Figure 5-14). The amount of flow is dependent on the length and ID of the capillary tube as well as the refrigerant charge.



**Figure 5-14 Capillary Tube and Drier Assembly**

#### CAPILLARY TUBE REMOVAL

#### NOTE

*The capillary tube assembly contains a drier. The entire assembly must be removed.*

- A. Recover refrigerant charge per instructions in Section 5.2.
- B. Leave a port open to prevent pressure buildup during capillary tube removal.
- C. Remove foam insulation from the capillary tube at the evaporator inlet.
- C. Unswear the capillary tube and remove.

#### CAPILLARY TUBE REPLACEMENT

- A. Position the capillary tube in the refrigeration system.
- B. Apply a heat sink (wet cloth) to the capillary tube and drier assembly.
- C. With the suction and discharge ports open, braze the capillary tube into the system.
- D.. Replace foam insulation to the capillary tube at the evaporator inlet.
- E. Evacuate the system per instructions in Section 5.2.
- F. Recharge the system per instructions in Section 5.3.

## SECTION 6 ELECTRICAL AND MECHANICAL CONTROL SYSTEMS

### NOTE

The wiring diagram is available in Section 8.

### 6.1 INTELLITEC2™ CONTROL

The IntelliTec2™ control consists of three main components; a control board, a display board and a membrane switch (touchpad).

The control board is modular and consists of a program board and a relay board. The two boards make it easy to service and replace. The boards are connected by two screws.

### 6.2 CONTACTORS

The F231 has a total of three contactors. One for the compressor and one for each drive motor. The contactors are located in the electrical box behind the right side panel.

The IntelliTec2™ control sends electronic signals to trigger the contactors. Separate signals are used to control each drive motor contactor and the compressor contactor. The signals to the contactors are staggered, so the drive motor will always start three seconds before the compressor. By staggering the starting and stopping of the drive motor, maximum starting torque is available and voltage spikes are reduced.

#### A. CONTACTOR TESTS

The following tests will show if a contactor is working properly.

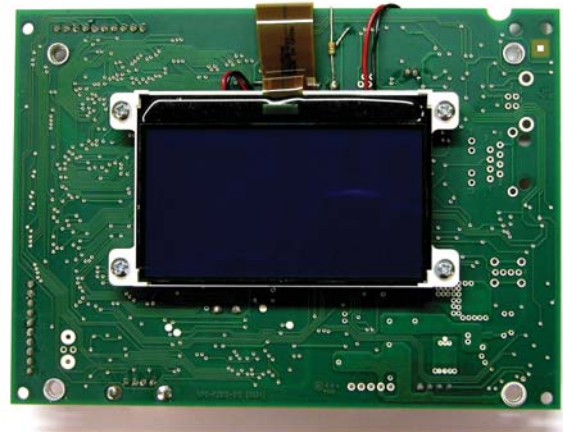

Figure 6-2 Display Board

1. Listen for the contactor to close. When the spigot is opened or the Push To Freeze button is pressed, the drive motor contactor will close. After three seconds, the compressor contactor will close.
2. Check to ensure contactor is receiving signal. Read voltage across the coils of the contactor during a freezing cycle. Voltage should be about 230V. If there is no voltage reading, refer to Section 7 Troubleshooting.

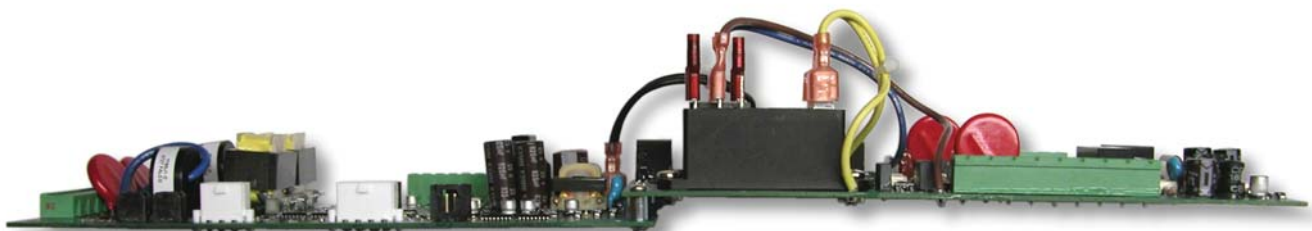
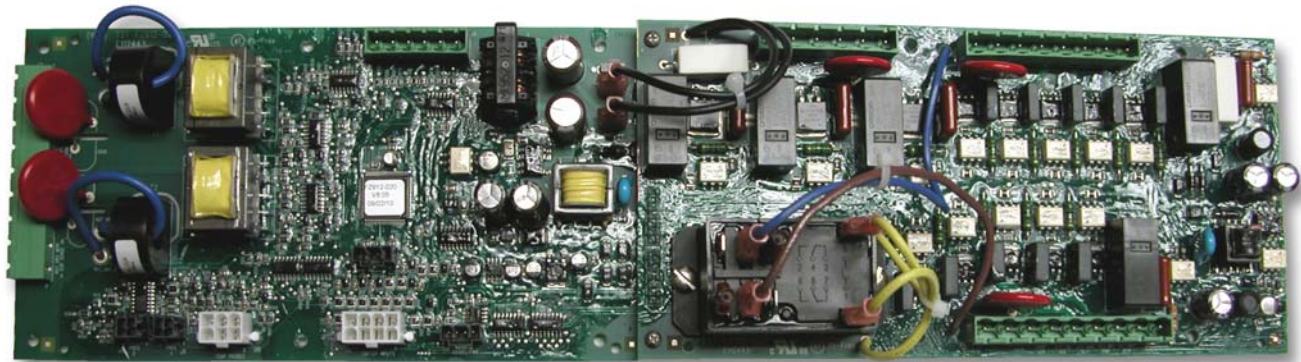

Figure 6-1 IntelliTec2™ Control Board

## 6.3 DRIVE MOTOR

The F231 has two drive motors. They are used to rotate the auger assemblies. An internal, normally closed, centrifugal switch starts the drive motor. The motors have an internal thermal overload.

### A. DRIVE MOTOR TEST

1. Turn the machine off by pressing the Main Power Off/On button and disconnect the machine from the electrical supply.



#### WARNING

##### Hazardous voltage

Make sure the machine is off when disassembling for servicing. The machine must be disconnected from electrical supply before removing any access panel. Failure to disconnect power before servicing could result in death or serious injury.

2. Remove the back panel and a side panel.
3. Loosen the belt tension adjustment nut and remove the belt.
4. Connect power to the machine.
5. Turn the machine on by pressing the Main Power Off/On button.
6. Press the right arrow, SET, then the SEL button to access the technician level on the control.
7. Activate the drive motor through the Left Output Control or Right Output Control menus which are located under Utilities in the Testing and Manual Operation screen. Refer to Section 4 for details.
8. Go to the Test Monitoring screen under Utilities. The motor current should not be above 3.5 on single phase machines or 3.8 on three phase machines.

#### NOTE

*The motor amps are based on 230VAC supply voltage.*

9. After the test, stop the motor by exiting the Testing and Manual Operation section. Turn the machine off and disconnect from the electrical supply.
10. Install the belt and tighten the tension bolt.
11. Use a Burroughs Belt Tension Gauge to set the tension for the drive belt. Set the belt tension to 40-45 lbs.
12. Using a straightedge, align the drive motor pulley with the gearbox pulley. Tighten the two allen head screws.

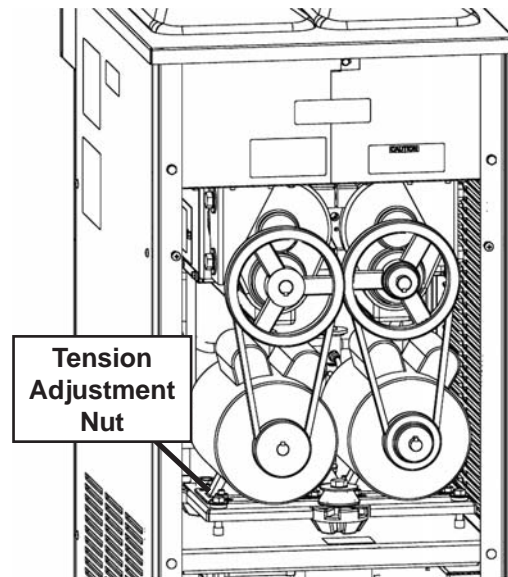

Figure 6-3 Belt Tension Adjustment

### B. DRIVE MOTOR REMOVAL

1. Disconnect machine from electrical supply before removing any panels for servicing.
2. Remove the back panel and the side panel.
3. Remove the electrical cover plate from the back of the motor.
4. Identify (mark) wires and remove them from the motor.
5. Loosen the belt tension adjustment bolt and remove the belt. (Refer to Figure 6-3)
7. Remove the motor mounting bolts.
8. Loosen the two allen head screws from the pulley.
9. Remove the pulley and key from the motor shaft.

### C. DRIVE MOTOR INSTALLATION

1. Place the drive motor in position and install the four mounting bolts.
2. Place the pulley and key on the motor shaft.

#### NOTE

*Do not tighten the pulley screws until after the belt tension has been properly adjusted.*

3. Install the belt and tighten the tension adjustment bolt.
4. Use a Burroughs Belt Tension Gauge to set the tension for the drive belt. Set the belt tension to 40-45 lbs.
5. Using a straightedge, align the drive motor pulley with the gearbox pulley. Tighten the two allen head screws.
6. Install wiring according to wiring diagram (located behind the left side panel). Install electrical cover plate on the motor.
7. Install back and side panels.

## 6.4 CAPACITORS

The compressor start and run capacitors are only on single phase machines. They are accessible by removing the right side panel.

The start and run capacitors for the drive motors are mounted directly onto each motor body.

### A. CAPACITOR TEST

1. Disconnect machine from electrical supply before removing any panels for servicing.

 <b>WARNING</b>
<b>Hazardous voltage</b> Make sure the machine is off when disassembling for servicing. The machine must be disconnected from electrical supply before removing any access panel. Failure to disconnect power before servicing could result in death or serious injury.

2. Remove a lead from one of the capacitor terminals.
3. Using insulated pliers, discharge the capacitor by connecting a 20KΩ 5W resistor across the terminals.

#### NOTE

*Discharge the capacitor even if there is a bleeder resistor across the terminals. There may be an open in the bleeder resistor preventing it from working properly.*

4. Disconnect the bleeder resistor from the circuit.
5. Measure the capacitance across the terminals. The results should be as follows:

	Part	Rating	
		MFD	VAC
Drive Motor Start	<a href="#">231095</a>	500 MFD	125 VAC
Drive Motor Run	<a href="#">231078</a>	50 MFD	370 VAC
Compressor Start	<a href="#">231079</a>	145-174 MFD	220 VAC
Compressor Start	<a href="#">230649</a>	130-156 MFD	250 VAC
Compressor Run	<a href="#">231084</a>	30 MFD	370 VAC

### B. CAPACITOR REPLACEMENT

1. Disconnect machine from electrical supply before removing any panels for servicing.
2. Remove leads from the capacitor terminals.
3. Using insulated pliers, discharge the capacitor with a 20KΩ 5W resistor across the terminals.

#### NOTE

*Discharge the capacitor even if there is a bleeder resistor across the terminals. There may be an open in the bleeder resistor preventing it from working properly.*

4. Pull the capacitor out of its holder and replace.
5. Connect the leads to the terminals of the new capacitor.

## 6.5 GEARBOX

### A. GEARBOX INSPECTION

Inspect the gearbox and listen for unusual noise. A grinding sound generally indicates a bad gear.

### B. GEARBOX REMOVAL

1. Disconnect machine from electrical supply before removing any panels for servicing.
2. Remove the back panel and the side panel.
3. Remove the four nuts holding the support bracket and remove the bracket.
4. Remove the belts.
5. Remove the bolts while holding the gearbox assembly and remove it.

### C. GEARBOX INSTALLATION

1. Place the gearbox in position from the rear of the machine. Fasten the bolts through the gearbox to the rear of the barrel.
2. Mount the pulley on the gearbox shaft and align with the motor pulley, then tighten the allen head screws.
3. Install the belt.
4. Use a Burroughs Belt Tension Gauge to set the tension for the drive belt. Set the belt tension to 40-45 lbs.
5. Using a straightedge, align the drive motor pulley with the gearbox pulley. Tighten the two allen head screws.
6. Install the support bracket to the gearbox.

## 6.6 CONDENSER FAN MOTOR (AIR-COOLED ONLY)

### A. FAN MOTOR REPLACEMENT

1. Disconnect machine from electrical supply before removing any panels for servicing.
2. Remove a side panel and the header panel.
3. Trace and disconnect the black and white wires on the fan motor.
4. Loosen the set screw on the fan blade.
5. Remove the bolts from the fan motor mounting plate and remove the motor.

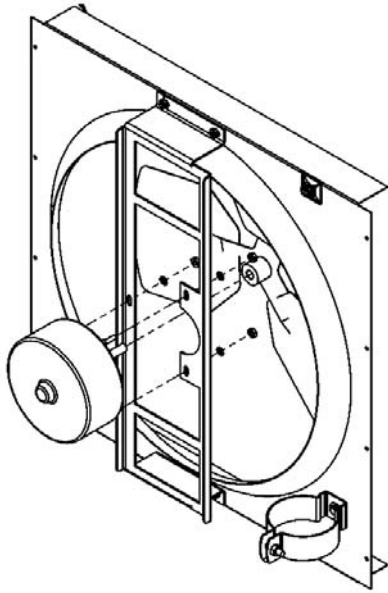

**Figure 6-4 Air Cooled Condenser**

## B. FAN MOTOR INSTALLATION

1. Attach motor to the mounting plate with the three bolts.
2. Place fan blade on motor shaft. Make sure the motor shaft does not extend past the hub of the fan blade. Tighten the set screw.

### NOTE

*The fan blades must be at least 3/8" from the fins on the condenser.*

3. Ensure purple wire is terminated.
4. Ensure red wire is terminated with blue wire.
5. Route the white and black wires through the side panel to the compressor contactor.
6. Connect black wire to the T1 terminal.
7. Connect white wire to the T2 terminal.

## 6.7 SPIGOT SWITCH

The spigot switch is a normally closed, held open switch. When a spigot is pulled, the spigot switch sends a signal to the IntelliTec2™ control to start the auger drive and refrigeration system. This signal moves the control to "Serve Mode", or if it already is in "Serve Mode", it resets the cycle count. After serving product, the IntelliTec2™ continues a freezing cycle until the product reaches consistency.

### SPIGOT SWITCH TEST - ADJUSTMENT

#### NOTE

*Adjustments to the spigot switch should be done after the product is at consistency in "Serve Mode" or when the machine is empty.*

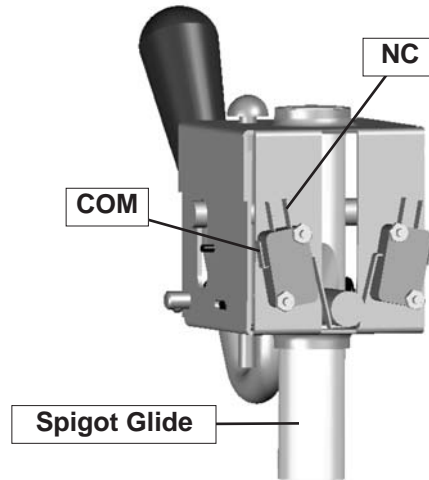

**Figure 6-5 Spigot Cam Assembly (Center Spigot)**

1. Open the spigot slowly and listen for a click when the spigot switch closes.
2. The clicking sound should be within the first 1/2" of the spigot glide movement (Refer to Figure 6-5). If the switch does not close, an adjustment may be necessary.

### NOTE

*The center spigot has two switches; one for each side. When testing the center spigot, there should be two audible clicks occurring almost simultaneously.*

### SPIGOT SWITCH TESTING - ELECTRICAL

1. Disconnect the switch from the circuit by unplugging the connectors.
2. Check resistance readings across the common (COM) and normally closed (NC) terminals. When the spigot is closed, the resistance should show an open. When the spigot is opened, the switch will close and the resistance should be 0 ohms.

### SPIGOT SWITCH ADJUSTMENT

1. Turn the machine off by pressing the Main Power On/Off button.
2. Remove the header panel.
3. Loosen the bolts on the spigot switch.
4. Using a pencil, mark the spigot glide 1/4" from the spigot housing.
5. Adjust the switch to activate when the plastic glide reaches the mark.
6. Fully tighten the retaining bolts and remove mark from spigot glide.

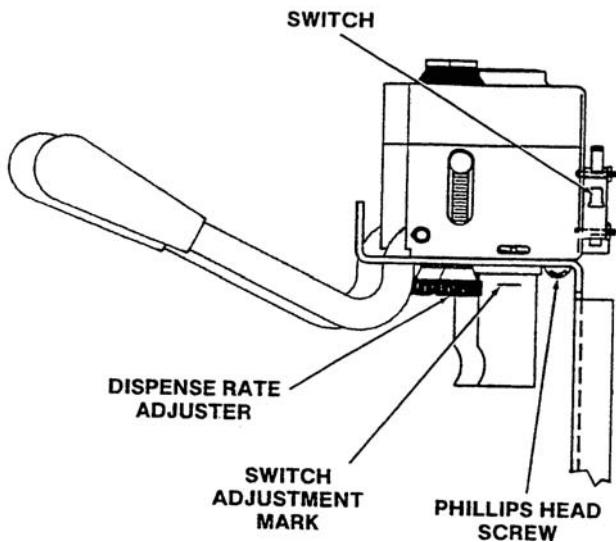

**Figure 6-6 Spigot Switch Replacement**

**SPIGOT SWITCH REPLACEMENT**

1. Remove the header panel.
2. Remove the dispense rate adjuster knob located below the header panel. (Refer to Figure 6-6)
3. Remove the two Phillips head screws that attach the spigot cam assembly to the panel. Remove the assembly.
4. Disconnect the connector from the switch and remove the switch..
5. Install the replacement switch onto the handle assembly. Do not fully tighten the retaining screws at this time.
6. Using a pencil, mark the spigot glide 1/4" from the spigot housing. Adjust the switch to activate when the spigot handle moves the glide to the mark.
7. Fully tighten the retaining screws.
8. Attach the connector to the spigot switch.
9. Position the spigot handle assembly in the electrical box and fasten securely with the two Phillips head screws.
10. Replace the dispense rate adjuster knob and tighten.
11. Replace the header panel and secure with the two Phillips head screws.

**6.8 TEMPERATURE CONTROL SENSOR**

The temperature control sensor is a thermistor used to sense the temperature of the suction line. As the suction line temperature increases, the internal resistance of the thermistor will decrease. Refer to Figure 6-7 for the relationship between sensor resistance and temperature. The IntelliTec control board monitors this value. In "Serve Mode", when the temperature of the sensor equals the Cut In T value on the control, a freezing cycle will start.

When troubleshooting a sensor, refer to the wiring diagram and remove the wires from the control board. Measure the resistance of the sensor and compare it with the table below. If the resistance is not within this range, replace it.

°F	Resistance	°F	Resistance
-22	176950	40	26100
-20	165200	42	24725
-18	154300	44	23400
-16	144200	46	22175
-14	134825	48	21000
-12	126125	50	19900
-10	118050	52	18875
-8	110550	54	17900
-6	103550	56	17000
-4	97075	58	16125
-2	91025	60	15325
0	85400	62	14550
2	80150	64	13825
4	75275	66	13150
6	70725	68	12500
8	66475	70	11875
10	62500	72	11300
12	58800	74	10750
14	55325	76	10250
16	52100	78	9750
18	49075	80	9300
20	46250	82	8850
22	43600	84	8450
24	41125	86	8050
26	38800	88	7675
28	36625	90	7325
30	34575	92	7000
32	32675	94	6675
34	30875	96	6375
36	29175	98	6100
38	27600	100	5825

**Figure 6-7 Temperature Sensor Resistance (10K Ohms)**



## SECTION 7 TROUBLESHOOTING

### 7.1 ERROR CODES

When the machine experiences a problem, one of the following error codes will be displayed on the control panel. Each error code directs you to the system location of the malfunction.

#### ERROR CODE MALFUNCTION

2	High Torque
3	Run Time
4	Clean
5	Freezing Cylinder Sensor
6	Hopper Sensor (single hopper machines)
7	Drive Motor
8	Cab Sensor
9	High Pressure Cutout
10	Ambient Sensor
11	Prime (cab units only)
12	Left Storage Sensor
13	Right Storage Sensor

To return the machine to normal operation, any error causing condition must be corrected and the freezing cylinder must be turned off and on again using the On/Off Left or On/Off Right button.

### 7.2 TROUBLESHOOTING

#### ERROR CODE 2 - HIGH TORQUE

If the control panel displays a High Torque Error (E2), the drive motor is running at a high load for 10 or more seconds. Very low and/or fluctuating supply voltages typically cause this error. The error can also be caused by faulty motor or starting components which could produce a high amp draw.

#### ERROR CODE 3 - RUN TIME

The Run Time Error (E3) occurs when the compressor runs continuously for an extended period. This error could happen if the cutout parameter is not attained. This error is generally caused by very low mix levels in the hopper or from product breakdown. Another common cause results from a restriction preventing mix from entering the freezing cylinder. Check the mix on the affected freezing cylinder. If the level mix is low, add mix. If there is a possibility that the mix is broken down, clean and sanitize the machine and replace the mix with fresh product.

Ice crystals in the hopper can clog the mix inlet regulator and prevent mix from entering the freezing cylinder. Thoroughly thaw mix per manufacturer's recommendations. To check for ice crystals, pour a small amount of product from the hopper through a clean and sanitized sieve or strainer. If ice crystals are in the mix, check the temperature of the walk-in cooler where the mix is stored or the temperature of the machine's hopper. If the hopper is below 34°F (1°C), adjust the temperature by raising the Storage Cutout value in the Storage Settings menu.

The Run Time Error may also occur if airflow within the machine has reduced or stopped. Check the sides and top of the machine for anything that would restrict airflow. Check the condenser filter and clean if necessary. Check the evaporator for frost that could restrict airflow.

The compressor will run continuously if a solenoid valve fails to open. This could be due to loose wiring, magnetic coil failure, a stuck valve or a faulty control board.

After the cause of the problem is found and remedied press the On/Off button for the cylinder to turn it off then back on.

#### ERROR CODE 4 - CLEAN

If the machine is left in the Clean Mode for more than 20 minutes, the control panel will display a Clean Error (E4). This condition does not reflect a problem with the machine itself. The Clean Error has been programmed into the controller as a safeguard to protect the machine from potential damage caused by the machine being accidentally left in "Clean Mode". To clear the Clean Error, press the On/Off button for the cylinder to turn it off then back on.

## ERROR CODE 5 - FREEZING CYLINDER SENSOR

The Freezing Cylinder Sensor Error (E5) indicates a failure of the barrel sensor or if the sensor is out of range. If the control panel displays an E5, press the On/Off button for the cylinder to turn it off then back on. If the control panel still displays the error code, refer to the machine's wiring diagram and the Temperature Sensor Chart (Figure 7-1). Check each lead of the sensor to ground for continuity. If continuity is found, replace the sensor. To check the resistance of the sensor, place a thermocouple on the suction line at the exit of the freezing cylinder. Compare temperature and sensor resistance with the table as reference. If measured value does not coincide with a value on the table ( $\pm 500$  ohms), replace the sensor.

### NOTE

*When the machine encounters a Freezing Cylinder Sensor Error, the machine will continue to run using preset timers. This mode will allow the operator to continue serving product until the machine can be serviced.*

°F	Resistance	°F	Resistance
-22	176950	40	26100
-20	165200	42	24725
-18	154300	44	23400
-16	144200	46	22175
-14	134825	48	21000
-12	126125	50	19900
-10	118050	52	18875
-8	110550	54	17900
-6	103550	56	17000
-4	97075	58	16125
-2	91025	60	15325
0	85400	62	14550
2	80150	64	13825
4	75275	66	13150
6	70725	68	12500
8	66475	70	11875
10	62500	72	11300
12	58800	74	10750
14	55325	76	10250
16	52100	78	9750
18	49075	80	9300
20	46250	82	8850
22	43600	84	8450
24	41125	86	8050
26	38800	88	7675
28	36625	90	7325
30	34575	92	7000
32	32675	94	6675
34	30875	96	6375
36	29175	98	6100
38	27600	100	5825

**Figure 7-1 Temperature Sensor Resistance  
(10K Ohms)**

## ERROR CODE 6 - HOPPER SENSOR

The Hopper Sensor Error (E6) will not occur on the F231.

## ERROR CODE 7 - DRIVE MOTOR

If the control panel displays a Drive Motor Error (E7), the control does not sense the drive motor. Press the On/Off button for the cylinder to turn it off then back on. If the error returns, use the machine's wiring diagram and check connections at the IntelliTec control and at the motor. An E7 may also be the result of a faulty drive motor contactor.

## ERROR CODE 8 - CAB SENSOR

A Cab Sensor Error (E8) will not occur on the F231.

## ERROR CODE 9 - HIGH PRESSURE CUTOUT

High Pressure Cutout Errors (E9) are usually caused by a dirty or inefficient condenser. If the control panel displays an E9, press the On/Off button for the cylinder to turn it off. Wait for 8-10 minutes for the machine pressures stabilize and an the internal timer to expire then press the On/Off button for the cylinder to turn it back on.

In air cooled condenser models, check the air filter to make sure it is clean. Replace or clean the filter as required. Check for proper air clearance around the machine. Refer to the machine's Owner's Manual for clearances. Check the condenser for blockage, and be sure condenser fan is functioning.

On water cooled condenser models, check for proper water flow through the condenser coil.

After the cause of the error is determined and corrected, press the On/Off button for the cylinder to turn it off then back on.

## ERROR CODE 10 - AMBIENT SENSOR

The Ambient Temperature Sensor Error (E10) indicates a failure of the condenser air inlet temperature sensor or if the sensor is out of range. If the control panel displays an E10, press the On/Off button for the cylinder to turn it off then back on. If the control panel still displays the error condition code, refer to the machine's wiring diagram and the Temperature Sensor Chart (Figure 7-1). Check each lead of the sensor to ground for continuity. If continuity is found, replace the sensor. To check the resistance of the sensor, place a thermocouple on the suction line at the exit of the freezing cylinder. Compare temperature and sensor resistance with the table as reference. If measured value does not coincide with a value on the table ( $\pm 400$  ohms), replace the sensor.

### **ERROR CODE 11 - PRIME**

The Prime Error (E11) will not occur on the F231.

### **ERROR CODE 12 - LEFT HOPPER SENSOR**

The Left Hopper Sensor Error (E12) indicates a failure of the hopper sensor or if the sensor is out of range. If the control panel displays an E12, press the On/Off button for the cylinder to turn it off then back on. If the control panel still displays the error condition code, refer to the machine's wiring diagram and the Temperature Sensor Chart (Figure 4-1). Check each lead of the sensor to ground for continuity. If continuity is found, replace the sensor. To check the resistance of the sensor, place a thermocouple on the suction line at the exit of the freezing cylinder. Compare temperature and sensor resistance with the table as reference. If measured value does not coincide with a value on the table ( $\pm 400$  ohms), replace the sensor.

### **ERROR CODE 13 - RIGHT HOPPER SENSOR**

The Right Hopper Sensor Error (E13) indicates a failure of the hopper sensor or if the sensor is out of range. If the control panel displays an E13, press the On/Off button for the cylinder to turn it off then back on. If the control panel still displays the error condition code, refer to the machine's wiring diagram and the Temperature Sensor Chart (Figure 4-1). Check each lead of the sensor to ground for continuity. If continuity is found, replace the sensor. To check the resistance of the sensor, place a thermocouple on the suction line at the exit of the freezing cylinder. Compare temperature and sensor resistance with the table as reference. If measured value does not coincide with a value on the table ( $\pm 400$  ohms), replace the sensor.

### **ERROR CODE 14 - NO CURRENT**

The No Current Error (E14) occurs during the refrigeration cycle. The control monitors amperage of the drive motor. If the amperage reading is too low, the control will attempt to restart the contactor and an the error gets logged. There will not be any interruption to normal operation and there will not be any notification of this error. If the error does not clear after 3 attempts, a Drive Motor Error (E7) will occur.

### **ERROR CODE 15 - LOW TORQUE**

The Low Torque Error (E15) occurs during the freezing cycle. If the product is above the Consistency CutIn and doesn't reach the Consistency CutOut in 20 minutes then the Low Torque Error will be logged for future analysis. The Low Torque error is a soft error. There will not be any interruption to normal operation and there will not be any notification of this error.

### **ERROR CODE 21 - SPIGOT OPEN TIME**

The Spigot Open Time Error (E21) indicates a failure of the spigot switch. If the control senses the spigot is open continuously for 10 minutes, the machine will go into Sleep 3 mode. If the control panel displays an E21, test the spigot switch then press the On/Off button for the cylinder to turn it off then back on.

## 7.3 TROUBLESHOOTING - MACHINE

PROBLEM	POSSIBLE CAUSE	REMEDY
<b>Machine does not run.</b>	<ol style="list-style-type: none"> <li>1 Power to machine is off.</li> <li>2 Front door not in place.</li> </ol>	<ol style="list-style-type: none"> <li>1 Supply power to machine.</li> <li>2 Assemble front door in place.</li> </ol>
<b>Machine will not shut off.</b>	<ol style="list-style-type: none"> <li>1 Drive belt failure.</li> <li>2 Consistency temperature setting is too firm.</li> <li>3 Refrigeration problem.</li> </ol>	<ol style="list-style-type: none"> <li>1 Replace drive belt.</li> <li>2 Adjust the CutOut Consistency Offset (See Section 4)</li> <li>3 Check system.</li> </ol>
<b>Product is too firm.</b>	<ol style="list-style-type: none"> <li>1 CutOut Consistency setting too high</li> </ol>	<ol style="list-style-type: none"> <li>1 Adjust the CutOut Consistency Offset (See Section 4)</li> </ol>
<b>Product is too soft.</b>	<ol style="list-style-type: none"> <li>1 No vent space for free flow of cooling air.</li> <li>2 Condenser is dirty.</li> <li>3 CutIn Consistency setting too low if the cycle time is correct</li> <li>4 CutOut Consistency setting too low if the cycle time is too short</li> <li>5 Auger is assembled incorrectly.</li> <li>6 Refrigeration problem.</li> </ol>	<ol style="list-style-type: none"> <li>1 A minimum of 3" of air space on both sides for proper circulation. (See Section 2)</li> <li>2 Clean the condenser. (See Section 4)</li> <li>3 Adjust the CutIn Consistency Offset (See Section 4)</li> <li>4 Adjust the CutOut Consistency Offset (See Section 4)</li> <li>5 Remove mix, clean, reassemble, sanitize and freeze down.</li> <li>6 Check system.</li> </ol>
<b>Product does not dispense.</b>	<ol style="list-style-type: none"> <li>1 No mix in hopper.</li> <li>2 Drive motor overload tripped.</li> <li>3 Drive belt failure.</li> <li>4 Freeze-up (Auger will not turn).</li> </ol>	<ol style="list-style-type: none"> <li>1 Add mix to the hopper.</li> <li>2 Wait for automatic reset. (If condition continues, call distributor for service.)</li> <li>3 Replace drive belt.</li> <li>4 Turn off cylinder, wait for 15 minutes, then restart.</li> </ol>
<b>Drive belt slipping or squealing.</b>	<ol style="list-style-type: none"> <li>1 Worn drive belt.</li> <li>2 Freeze-up (Auger will not turn).</li> <li>3 Not tensioned properly.</li> </ol>	<ol style="list-style-type: none"> <li>1 Replace drive belt.</li> <li>2 Turn off cylinder, wait for 15 minutes, then restart.</li> <li>3 Adjust belt tension</li> </ol>
<b>Rear auger seal leaks.</b>	<ol style="list-style-type: none"> <li>1 Outside surface of rear auger seal is lubricated.</li> <li>2 Rear seal missing or damaged.</li> <li>3 Seal o-ring missing, damaged or installed incorrectly.</li> <li>4 Worn or scratched auger shaft.</li> </ol>	<ol style="list-style-type: none"> <li>1 Clean lubricant from outside of rear seal, lubricate inside of seal and reinstall.</li> <li>2 Check or replace.</li> <li>3 Check or replace.</li> <li>4 Replace auger shaft.</li> </ol>
<b>Front door leaks.</b>	<ol style="list-style-type: none"> <li>1 Front door knobs are loose.</li> <li>2 Spigot parts are not lubricated.</li> <li>3 Chipped or worn spigot o-rings.</li> <li>4 O-rings or spigot installed wrong.</li> <li>5 Inner spigot hole in front door nicked or scratched.</li> </ol>	<ol style="list-style-type: none"> <li>1 Tighten knobs.</li> <li>2 See Section 3.</li> <li>3 Replace o-rings.</li> <li>4 Remove spigot and check o-ring.</li> <li>5 Replace front door.</li> </ol>

## SECTION 8 REPLACEMENT PARTS

### 8.1 DECALS, LUBRICATION AND MISCELLANEOUS

Part	Description	Quantity
208135	Brush - 4" X 8" X 16" (Barrel)	1
208380	Brush - 1/4" X 3" X 14"	1
208401	Brush - 1" X 3" X 10"	1
208467	Brush - 3/8" X 1" X 5"	1
229158	USB Cable Extension	-
236059	Card - Cleaning Instructions	1
244052	Caster - Locking (2") (Each)	2
244053	Caster - Non-Locking (2") (Each)	2
244138	Caster - Non-Locking (4") (Each)	2
244139	Caster - Locking (4") (Each)	2
324065	Decal - Water Inlet	1
324103	Decal - Caution Rotating Shaft	1
324105	Decal - Caution Electrical Shock	1
324106	Decal - Caution Electrical Wiring Materials	1
324107	Decal - Caution Hazardous Moving Parts	1
324125	Decal - Danger Electric Shock Hazard	1
324141	Decal - Caution Rotating Blades	1
324208	Decal - Attention Refrigerant Leak Check	1
324393	Decal - Stoelting Swirl Logo	1
324509	Decal - Cleaning Instructions	1
324566	Decal - Wired According To	1
324584	Decal - Adequate Ventilation 3"	3
324594	Decal - Attention Heat Sensitive	4
324686	Decal - Danger Automatic Start	1
324803	Decal - Domed Stoelting Logo (Large) (Header Panel)	1
324908	Decal - Rear Light	2
324909	Decal - USB Port	1
324910	Decal - Air Deflector	1
508048	Lubricant - Spline (2 oz Squeeze Tube)	1
508135	Petrol Gel - 4 oz Tube	1
513658	Manual - Owner's	1
1159501	O-Ring & Bushing Kit	1
2202790	Floor Baffle (Air Deflector)	1
2202857	Kit - Mix Low Light	-
2203790	Sensor Probe Kit	-

### 8.2 PANELS AND SCREWS

Part	Description	Quantity
647658	Screw - Header Panel	2
647660	Screw - Sides & Rear Panel	-
649114	Screw - Upper Front Panel	4
2202322	Panel - R.H. Side (Air-Cooled / Water-Cooled)	1
2202323	Panel - L.H. Side (Air Cooled)	1
2202327	Panel - Header	1
2202328	Panel - Front w/Tray Support	1
2202329	Panel - Lower Front	1
2202459	Panel - L.H. Side (Water-Cooled)	1
2202460	Panel - Rear (Air-Cooled / Water-Cooled)	1

### 8.3 AUGER SHAFT AND FACEPLATE PARTS

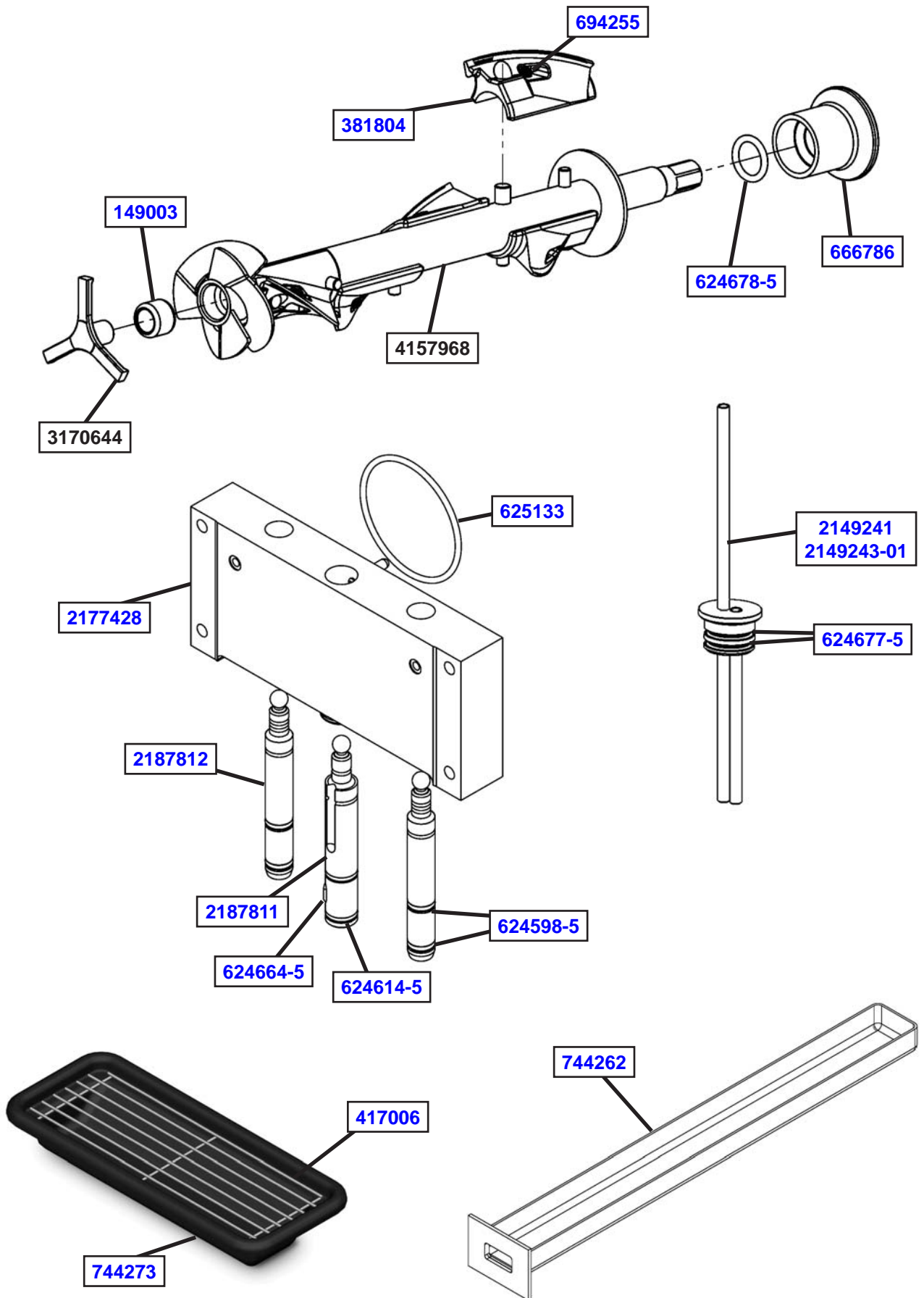

### 8.3 AUGER SHAFT AND FACEPLATE PARTS (CONTINUED)

Part	Description	Quantity
149003	Bushing - Front Auger Support	2
232734	Cap - Rosette	3
314453	Cover - Hopper	2
381804	Auger Flight	8
417006	Grid - Drip Tray ( Vinyl Coated Metal)	1
482019	Knob - Front Door (Black)	4
624598-5	O-Ring - Outside Spigot - Black (5 Pack)	4
624614-5	O-Ring - Top & Bottom Center Spigot - Black (5 Pack)	2
624664-5	O-Ring - Middle Center Spigot - Black (5 Pack)	1
624677-5	O-Ring - Mix Inlet - Black (5 Pack)	4
624678-5	O-Ring - Rear Seal - Black (5 Pack)	2
625133	O-Ring - Front Door - Red	2
666786	Seal - Rear Auger - Black	2
694255	Spring - Auger Flight	8
744262	Tray - Drain (Black Plastic)	1
744273	Tray - Drip	1
2149241	Mix Inlet Assembly - 5/16" Hole - Extended Length (2C)	-
2149243-01	Mix Inlet Assembly - 3/16" Hole - Extended Length (2A)	2
2177072	Extension - Spigot - 1.5"	-
2177073	Extension - Spigot - 2.5"	-
2177074	Extension - Spigot - 3.2"	-
2177428	Door w/Pins	1
2187811	Spigot Body - Center	1
2187812	Spigot Body - Outer	2
3170644	Support - Front Auger	2
4157968	Auger Shaft	2

### 8.4 AIR PLENUM KIT

Part	Description	Quantity
324912	Decal - Avoid Spills	1
357037	Axial Fan	1
431111	Wiring Harness	1
2202812	Plenum	1
2202922	Bracket - Axial Fan	1
2202989	Control Box Cover	1
2202990	Electrical Box Cover	1

## 8.5 INTERNAL COMPONENTS

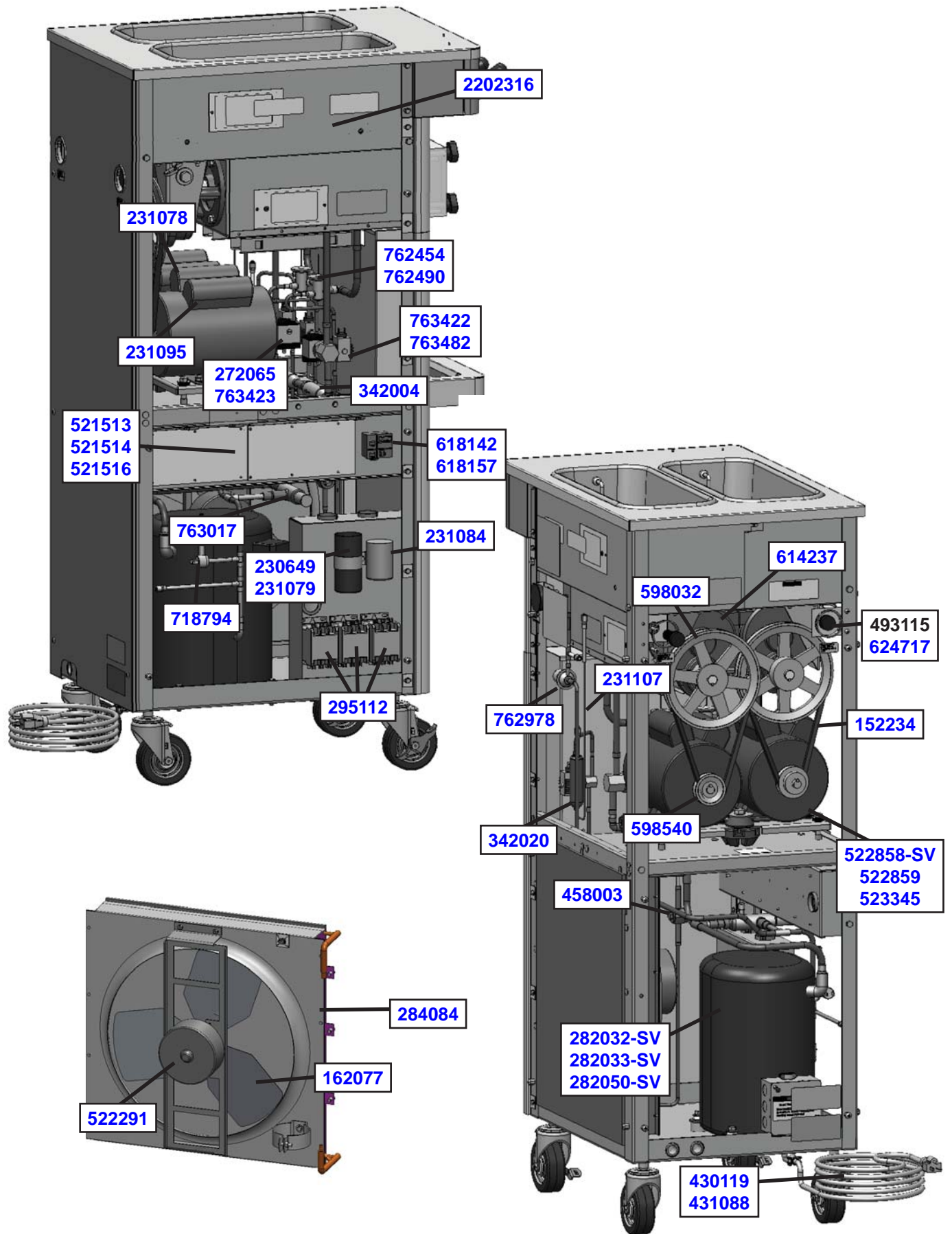

## 8.5 INTERNAL COMPONENTS (CONTINUED)

Part	Description	Quantity
152231	Belt - Gripnotch (AX32) (1 per Side) (Ser. #0 - #33842)	2
152234	Belt - Gripnotch (AX33) (1 per Side) (Ser. #33725, #33737, #33739 & #33843 Plus)	2
162077	Blade - Fan (Air-Cooled Condenser)	1
229148	Cable - IntelliTec2™ (Control Board to Display Board)	1
230649	Capacitor - Start (#282050 Compressor)	1
231078	Capacitor - Run (#522858 Motor)	1
231079	Capacitor - Start (#282032 Compressor)	1
231084	Capacitor - Run (#282032 or #282050 Compressors)	1
231095	Capacitor - Start (#522858 Motor)	1
231107	Cap Tube	1
272065	Valve Coil - Solenoid (#763423 Valve)	2
282032-SV	Compressor - Copeland 1 PH - 60 Hz - R404A (No Capacitors)	1
282033-SV	Compressor - Copeland 3 PH (60 Hz)	1
282050-SV	Compressor - 1 PH (50 Hz) (No Capacitors)	1
284084	Condenser (Air-Cooled)	1
284104	Condenser (Water-Cooled)	1
295112	Contactora - Compressor / Drive	3
342004	Drier (Liquid Line)	1
342020	Drier (Hopper Liquid Line) (Cap Tube)	1
368140	Filter - Air (Condenser)	1
430119	Cord - Power (1 PH)	1
431088	Cord - Power (3 PH)	1
458003	Sight Glass	1
493115	Light - Red LED (Mix Low)	2
521513	Board - Program (IntelliTec2™)	1
521514	Board - Relay (IntelliTec2™)	1
521516	Board - Program / Relay (IntelliTec2™)	1
522291	Motor - Fan (Air-Cooled Condenser)	1
522858-SV	Motor - Drive (1 PH) (60 Hz)	2
522859	Motor - Drive (1 PH) (50 Hz)	2
523345	Motor - Drive (3 PH) (60 Hz)	2
598031	Pulley - Drive Motor (60 Hz) (Ser. #0-33842)	2
598032	Pulley - Speed Reducer (Ser. #33843 Plus)	2
598072	Pulley - Drive Motor (50 Hz)	2
598296	Pulley - Speed Reducer (60 Hz - Ser. #0 - #33842) (50 Hz)	2
598540	Pulley - Drive Motor (60 Hz) (Ser. #33843 Plus)	2
614237	Speed Reducer	2
618142	Relay (#282050 Compressor)	1
618157	Relay (#282032 Compressor)	1
624717	O-Ring - Mix Low Lens	2
718537	Switch - Limit (Door Interlock)	1
718794	Switch - High Pressure Cutout	1
762359	Valve Core (Schradler)	3
762454	Valve - Expansion	2
762490	Valve - Expansion (AXV)	2
762978	Valve - EPR	1
763017	Valve - Hot Gas Bypass	1
763181	Valve - Water	1
763422	Valve - Solenoid (1/4") (Liquid Line)	3
763423	Valve - Solenoid (1/2") (Suction Side)	2
763482	Valve Coil - Solenoid (#763422)	3
764385	Valve Kit - Water Valve Repair	-
2202316	Evaporator / Hopper Assembly	1
2203532	Switch Assembly - Door Interlock	1

## 8.6 SPIGOT ASSEMBLY

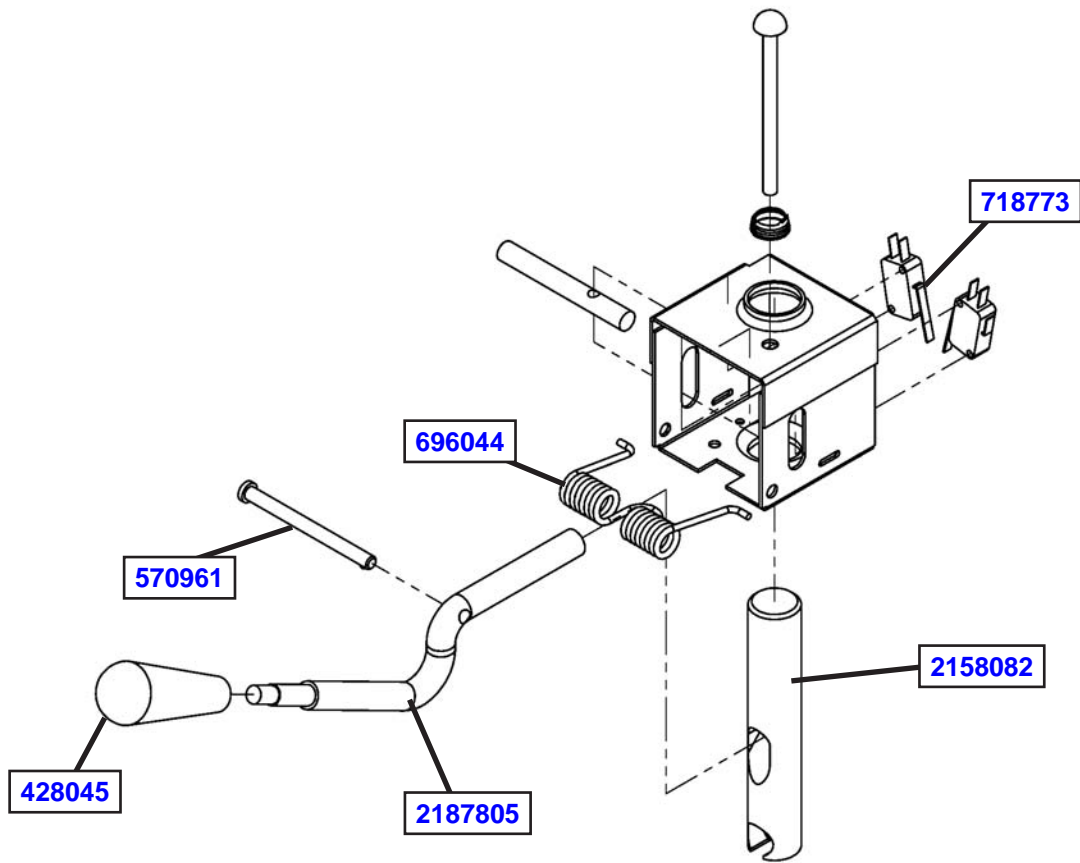

Part	Description	Quantity
428045	Knob - Spigot Handle (Black)	3
570961	Pin - Cotterless Clevis (Spigot Cam)	3
696044	Spring - Torsion (Spigot Cam)	3
718773	Switch - Limit (Spigot Cam)	3
2158082	Glide - Spigot Socket	3
2187805	Handle - Spigot (Handle Only)	3

## 8.7 FRONT

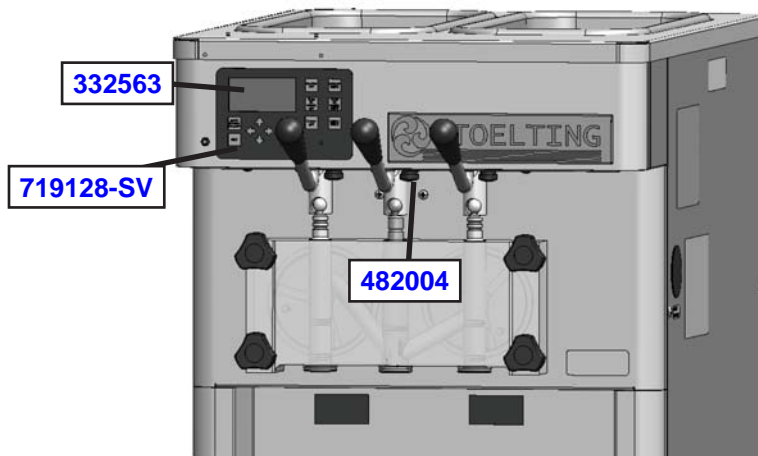

Part	Description	Quantity
332563	Board - Display Module (Display Only)	1
482004	Knob (Spigot Adjustment)	3
719128-SV	Switch - Membrane Switch (Touchpad & Ribbon)	1
1170826	Switch Assembly - Door Interlock	1

# 8.8 WIRING DIAGRAMS

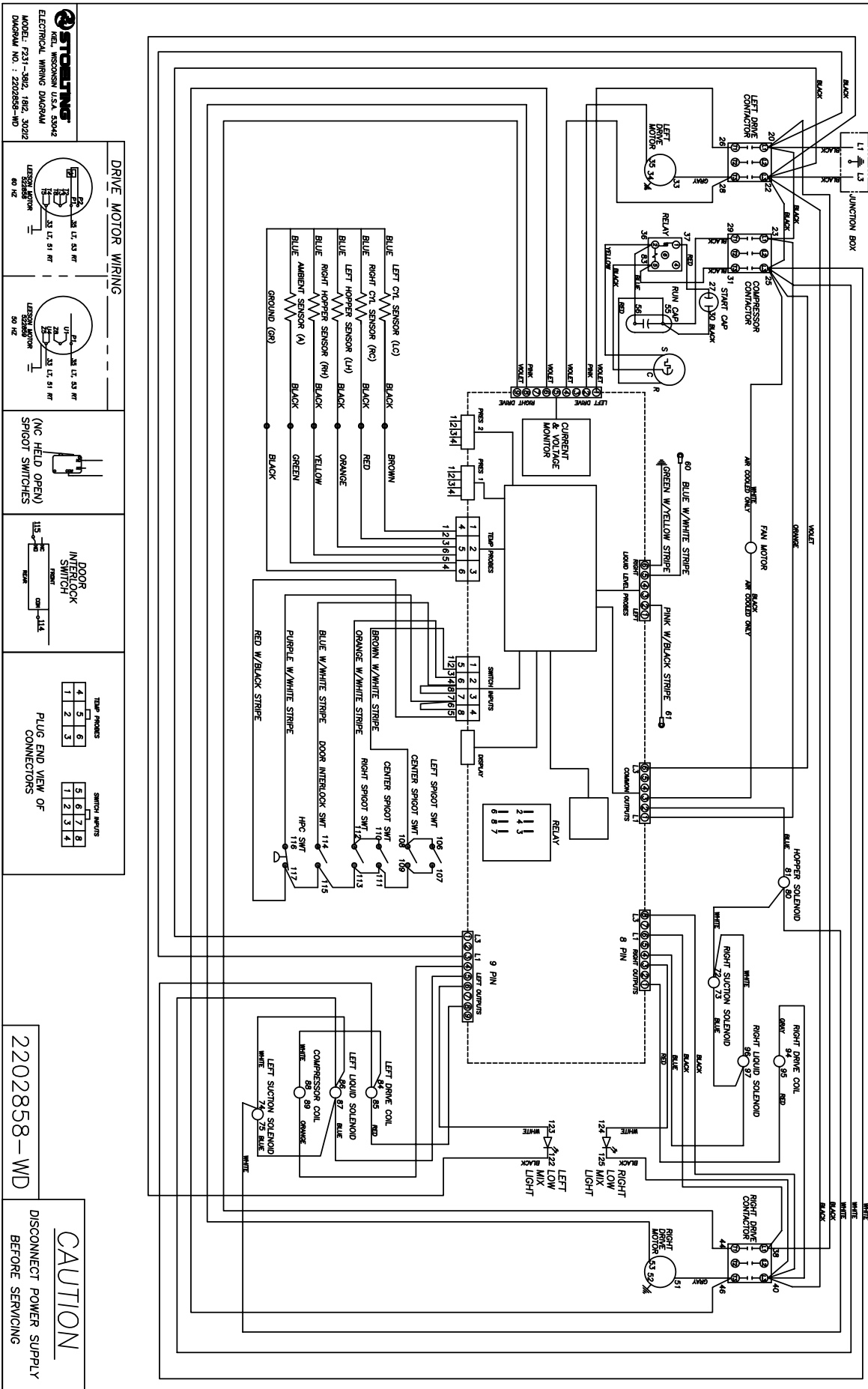

DRIVE MOTOR WIRING

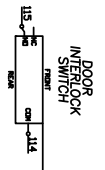
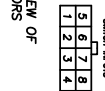
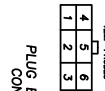
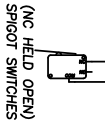
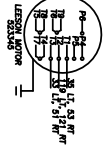

2202859-WD

**CAUTION**  
 DISCONNECT POWER SUPPLY  
 BEFORE SERVICING

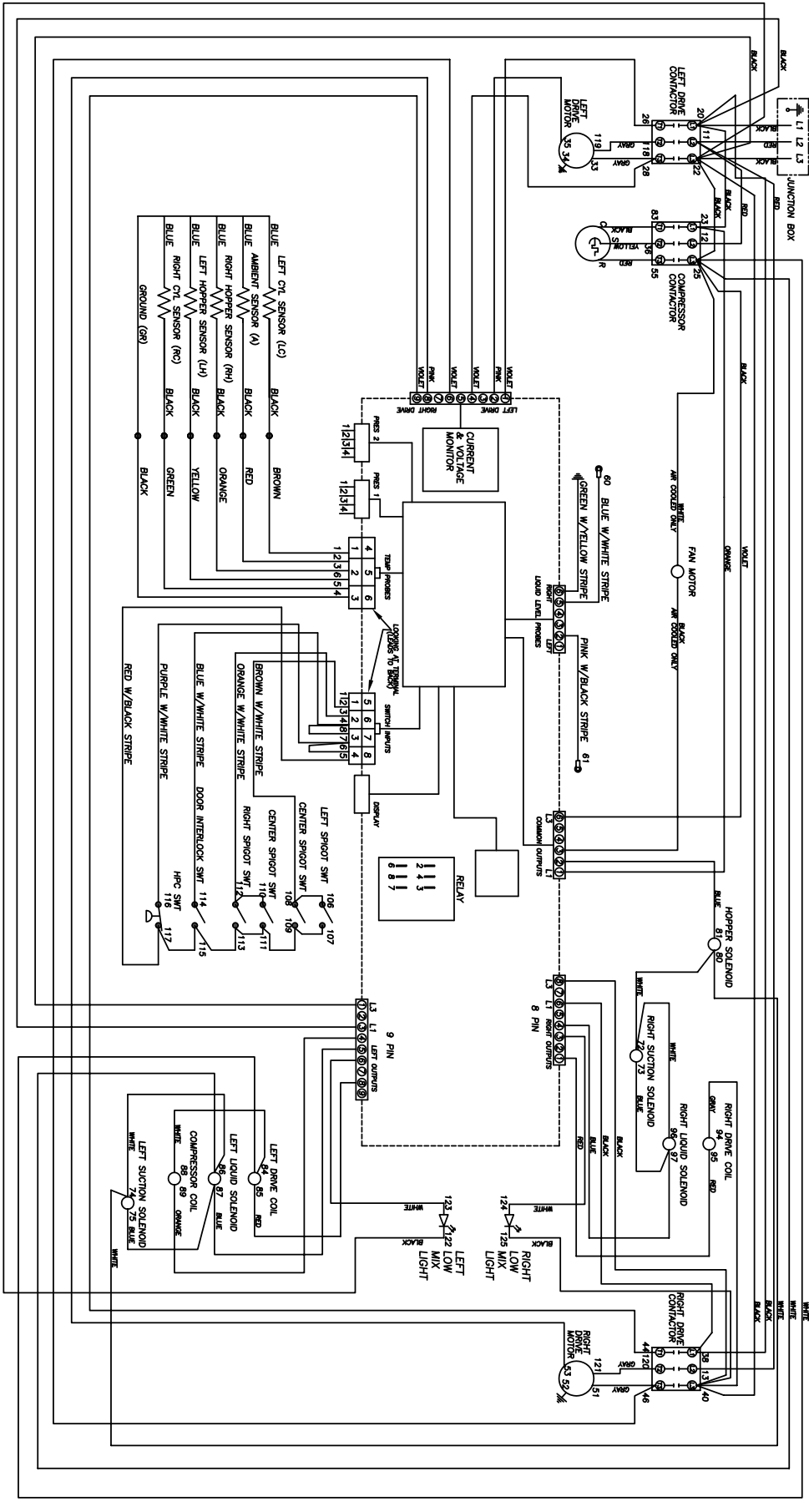



**DOMESTIC WARRANTY  
(Including Mexico)  
SOFT SERVE / SHAKE EQUIPMENT**

1. **Scope:**  
PW Stoelting, L.L.C. (“Stoelting”) warrants to the first user (the “Buyer”) that the freezing cylinders, hoppers, compressors, drive motors, speed reducers, and augers of Stoelting soft serve / shake equipment will be free from defects in materials and workmanship under normal use and proper maintenance appearing within five (5) years, and that all other components of such equipment manufactured by Stoelting will be free from defects in material and workmanship under normal use and proper maintenance appearing within twelve (12) months after the date that such equipment is originally installed.
  
2. **Disclaimer of Other Warranties:**  

**THIS WARRANTY IS EXCLUSIVE; AND STOELTING HEREBY DISCLAIMS ANY IMPLIED WARRANTY OF MERCHANTABILITY OR FITNESS FOR PARTICULAR PURPOSE.**
  
3. **Remedies:**  
Stoelting’s sole obligations, and Buyer’s sole remedies, for any breach of this warranty shall be the repair or (at Stoelting’s option) replacement of the affected component at Stoelting’s plant in Kiel, Wisconsin, or (again, at Stoelting’s option) refund of the purchase price of the affected equipment, and, during the first twelve (12) months of the warranty period, deinstallation/reinstallation of the affected component from/into the equipment. Those obligations/remedies are subject to the conditions that Buyer (a) signs and returns to Stoelting, upon installation, the Start-Up and Training Checklist for the affected equipment, (b) gives Stoelting prompt written notice of any claimed breach of warranty within the applicable warranty period, and (c) delivers the affected equipment to Stoelting or its designated service location, in its original packaging/crating, also within that period. Buyer shall bear the cost and risk of shipping to and from Stoelting’s plant or designated service location.
  
4. **Exclusions and Limitations:**  
This warranty does not extend to parts, sometimes called “wear parts”, which are generally expected to deteriorate and to require replacement as equipment is used, including as examples but not intended to be limited to o-rings, auger flights, auger seals, auger support bushings, and drive belts. All such parts are sold

**AS IS.**

Further, Stoelting shall not be responsible to provide any remedy under this warranty with respect to any component that fails by reason of negligence, abnormal use, misuse or abuse, use with parts or equipment not manufactured or supplied by Stoelting, or damage in transit.

**THE REMEDIES SET FORTH IN THIS WARRANTY SHALL BE THE SOLE LIABILITY STOELTING AND THE EXCLUSIVE REMEDY OF BUYER WITH RESPECT TO EQUIPMENT SUPPLIED BY STOELTING; AND IN NO EVENT SHALL STOELTING BE LIABLE FOR ANY INCIDENTAL OR CONSEQUENTIAL DAMAGES, WHETHER FOR BREACH OF WARRANTY OR OTHER CONTRACT BREACH, NEGLIGENCE OR OTHER TORT, OR ON ANY STRICT LIABILITY THEORY.**