



Model SC118
SERVICE MANUAL
Manual No. [513567](#)

This manual provides basic information about the machine. Instructions and suggestions are given covering its operation and care.

The illustrations and specifications are not binding in detail. We reserve the right to make changes to the machine without notice, and without incurring any obligation to modify or provide new parts for machines built prior to date of change.

DO NOT ATTEMPT to operate the machine until instructions and safety precautions in this manual are read completely and are thoroughly understood. If problems develop or questions arise in connection with installation, operation, or servicing of the machine, contact Stoelting.



stoeltingfoodservice.com

Stoelting Foodservice Equipment
502 Highway 67
Kiel, WI 53042-1600
U.S.A.

Main Tel: 800.558.5807
Fax: 920.894.7029

Customer Service: 888.429.5920
Fax: 800.545.0662
Email: foodservice@stoelting.com

© 2014 PW Stoelting, LLC

A Few Words About Safety

Safety Information

Read and understand the entire manual before operating or maintaining Stoelting equipment.

This manual provides the operator with information for the safe operation and maintenance of Stoelting equipment. As with any machine, there are hazards associated with their operation. For this reason safety is emphasized throughout the manual. To highlight specific safety information, the following safety definitions are provided to assist the reader.

The purpose of safety symbols is to attract your attention to possible dangers. The safety symbols, and their explanations, deserve your careful attention and understanding. The safety warnings do not by themselves eliminate any danger. The instructions or warnings they give are not substitutes for proper accident prevention measures.

If you need to replace a part, use genuine Stoelting parts with the correct part number or an equivalent part. We strongly recommend that you do not use replacement parts of inferior quality.



Safety Alert Symbol:

This symbol Indicates danger, warning or caution. Attention is required in order to avoid serious personal injury. The message that follows the symbol contains important information about safety.

Signal Word:

Signal words are distinctive words used throughout this manual that alert the reader to the existence and relative degree of a hazard.



The signal word “WARNING” indicates a potentially hazardous situation, which, if not avoided, may result in death or serious injury and equipment/property damage.



The signal word “CAUTION” indicates a potentially hazardous situation, which, if not avoided, may result in minor or moderate injury and equipment/property damage.

CAUTION

The signal word “CAUTION” not preceded by the safety alert symbol indicates a potentially hazardous situation, which, if not avoided, may result in equipment/property damage.

NOTE (or NOTICE)

The signal word “NOTICE” indicates information or procedures that relate directly or indirectly to the safety of personnel or equipment/property.

TABLE OF CONTENTS

SECTION	DESCRIPTION	PAGE
1. Introduction	1
2. Installation Instruction		
2.1 Safety Precautions	3
2.2 Shipment and Transit	3
2.3 Freezer Installation	3
2.4 Installing Permanent Wiring	4
3. Initial Set-Up and Operation		
3.1 Operator's Safety Precautions	5
3.2 Operating Controls and Indicators	5
3.3 Disassembly of Freezer Parts	5
3.4 Cleaning the Freezer Parts	7
3.5 Sanitize Freezer and Freezer Parts	7
3.6 Assembly of Freezer	7
3.7 Sanitizing	7
3.8 Initial Freeze Down and Operation	8
3.9 Consistency Adjustment	8
4. Maintenance		
4.1 Bulb Replacement	9
5. Refrigeration System		
5.1 Refrigeration System	11
5.2 Compressor	11
5.3 Condensers	12
5.4 Evaporators	13
5.5 Hopper	14
5.6 Capillary Tube	16
5.7 High Pressure Cutout Switch	17
6. Sequence of Operations		
6.1 Lights	19
6.2 Switches	19
6.3 Safety Switch	19
7. Electrical		
7.1 Electrical	21
7.2 Front Electrical Panel	21
7.3 Rear Electrical Panel	22
7.4 Major Component Replacement	24
8. Troubleshooting	29
9. Parts List & Drawings	31

LIST OF ILLUSTRATIONS

FIGURE	TITLE	PAGE
1	Model SC118	1
2	Specifications	2
3	Leveling Unit	3
4	Power Cord	4
5	Controls	5
6	Disassembling Freezer	5
7	Front Door and Auger Assembly	6
8	Rear Seal Assembly	6
9	Consistency Control Knob	8
10	Light Bulb	9
11	Nameplate	11
12	High Pressure Cut Out	11
13	Compressor Terminal Cover Removal	11
14	Compressor Connections	11
15	Ohm Meter Connection	12
16	Clearance For Air Flow	12
17	Condenser	12
18	Access Ports	13
19	TXV	13
20	Heat Sink	14
21	Drier	14
22	EPR & Schrader Valve	14
23	EPR Valve Adjustment	15
24	EPR Heat Sink	15
25	Filter Drier	16

LIST OF ILLUSTRATIONS

26	Drier Cap. Tube Assembly	16
27	Pressure Switch "T"	17
28	Pressure Switch	17
29	Electrical Panel	21
30	Switch/Indicator Removal	21
31	Light Bulb Replacement	21
32	Rear Electrical Panel	22
33	Temperature Control	23
34	Transformer	23
35	Safety Switch	23
36	Torque Switch	23
37	Liquid Level Control	24
38	Condenser Fan Motor	24
39	Condenser	25
40	Electrical Wires	25
41	Compressor	25
42	Torque Spring	26
43	Drive Motor/Siffener Bracket	26
44	Belt Tensioner	26
45	Bearing Assembly	27

SECTION 1 INTRODUCTION

The Stowaway is a countertop profit machine. This compact unit fits onto any crowded bar, yet its high capacity means it will turn out more than seven gallons every hour. And the Stowaway is as versatile as it is fast, dispensing frozen, pre-mixed or ready-to-serve blends all with the same smooth consistency.



Figure 1. Model SC118

Stowaway Features

- ☞ Easy plug-in installation.
- ☞ Lighted, moving product and front-mounted flavor label attract attention and merchandise product.
- ☞ Large 5.5 quart freezing cylinder serves cups, glasses or pitchers.
- ☞ Mix-low warning light notifies when to refill.
- ☞ Night-mode thermostat allows you to schedule cleaning frequency.
- ☞ Front air intake requires less counter space.
- ☞ Belt-drive system means quiet, dependable operation.
- ☞ Torque control ensures consistent quality product.

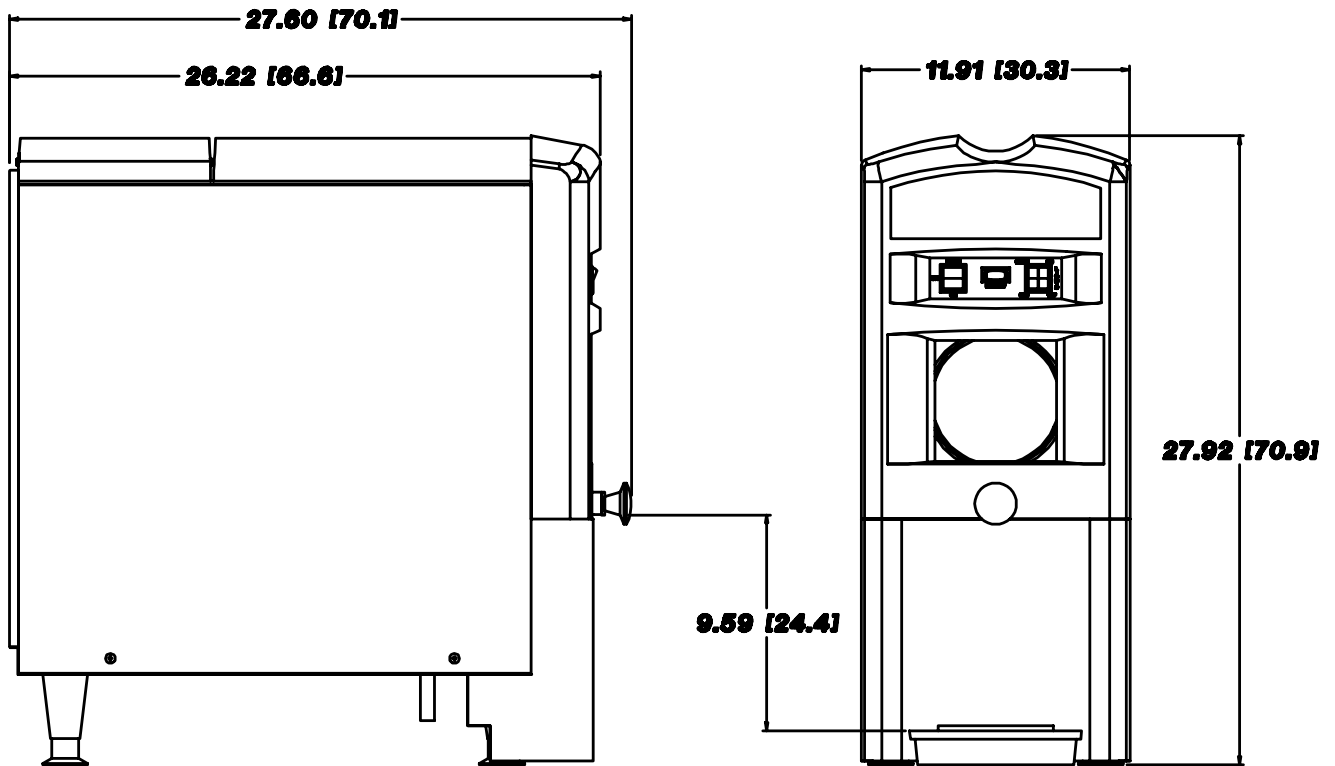

Figure 2. Specifications

Specifications

12 running amps 115/60/1

15-amp fuse

2.5 gallon (9.5 liter) hopper capacity

5.5 quart (5.2 liter) barrel capacity

1/3 horsepower drive motor

UL & C-UL approved, NSF approval pending

SECTION 2 INSTALLATION INSTRUCTIONS

2.1 SAFETY PRECAUTIONS

Do not attempt to operate the freezer until the safety precautions and operating instructions in this manual are read completely and are thoroughly understood.

Take notice of all warning labels on the freezer. The labels have been put there to help maintain a safe working environment. The labels have been designed to withstand washing and cleaning. All labels must remain legible for the life of the freezer. Labels should be checked periodically to be sure they can be recognized as warning labels.

If danger, warning or caution labels are needed, indicate the part number, type of label, location of label, and quantity required along with your address and mail to:

STOELTING, INC.
ATTENTION: Customer Service
502 Hwy. 67
Kiel, Wisconsin 53042



Figure 3. Leveling Unit

2.2 SHIPMENT AND TRANSIT

The freezer has been assembled, operated and inspected at the factory. Upon arrival at the final destination, the complete freezer must be checked for any damage which may have occurred during transit.

With the method of packaging used, the freezer should arrive in excellent condition. THE CARRIER IS RESPONSIBLE FOR ALL DAMAGE IN TRANSIT, WHETHER VISIBLE OR CONCEALED. **Do not** pay the freight bill until the freezer has been checked for damage. Have the carrier note any visible damage on the freight bill. If concealed damage and/or shortage is found later, advise the carrier within 10 days and request inspection. The customer must place claim for damages and/or shortages in shipment with the carrier. **Stoelting, Inc. cannot make any claims against the carrier.**

2.3 FREEZER INSTALLATION

Installation of the freezer involves moving the freezer close to its permanent location, removing all crating, setting in place, assembling parts, and cleaning.

WARNING

DO NOT USE SPIGOT SPOUT AS A HANDLE TO LIFT OR MOVE THE FREEZER.

- A. Uncrate the freezer.
- B. The freezer must be placed in a solid level position. To level adjust bottom portion of leg.
- C. Place all switches in the OFF position.



Figure 4. Power Cord

- D. Connect the power cord. The plug is designed for 115 volt/15 amp duty. The unit must be connected to a properly grounded receptacle. The electrical cord furnished as part of the freezer has a three prong grounding type plug. The use of an extension cord is not recommended. If one must be used, use one with a size 12 gauge or heavier with a ground wire. Do not use an adaptor to get around grounding requirements.

CAUTION

DO NOT ALTER OR DEFORM PLUG IN ANY WAY!

- E. Install the drip tray, cover and other miscellaneous parts on the freezer.

2.4 INSTALLING PERMANENT WIRING

If permanent wiring is required by local codes, the following procedure must be performed.

WARNING

DISCONNECT FREEZER FROM THE SOURCE OF ELECTRICAL SUPPLY BEFORE SERVICING.

- A. Remove the necessary panels to gain access to the power cord connection.
- B. Disconnect the black and white wires from the terminal block (L1 and common). Disconnect the green ground wire from the grounding screw.
- C. Remove the strain relief connector from the bottom of the freezer base. Remove the power cord.
- D. Install permanent wiring according to local code.
- E. Connect black wire to L1 on the terminal block. Connect the white wire to the common on the terminal block. Connect the green or yellow and green striped ground wire to the grounding screw.
- F. Replace all panels.

SECTION 3 INITIAL SETUP AND OPERATION

3.1 OPERATOR'S SAFETY PRECAUTIONS

SAFE OPERATION IS NO ACCIDENT; Observe these rules:

- A. **Know the freezer.** Read and understand the Operating Instructions.
- B. **Notice all warning labels on the freezer.**
- C. **Wear proper clothing.** Avoid loose fitting garments, and remove watches, rings or jewelry which could cause a serious accident.
- D. **Maintain a clean work area.** Avoid accidents by cleaning up the area and keeping it clean.
- E. **Stay alert at all times.** Know which switch, push button or control you are about to use and what effect it is going to have.
- F. **Disconnect electrical cord for maintenance.** Never attempt to repair or perform maintenance on the freezer until the main electrical power has been disconnected.
- G. **Do not operate under unsafe operating conditions.** Never operate the freezer if unusual or excessive noise or vibration occurs.

3.2 OPERATING CONTROLS AND INDICATORS

Before operating the freezer, it is required that the operator know the function of each operating control. Refer to Figure 8 for the location of the operating controls on the freezer.

A. Clean OFF ON Switch

The clean off on switch is a three position switch. In the clean position only the drive and condenser fan will run. In the ON position the drive and condenser fan and compressor will run until the proper consistency is reached, then the compressor will stop and the drive and condenser fan will continue to run.

B. Mix Low Light

The mix low light will illuminate when the liquid level in the hopper is less than 2".

C. Standby Serve Switch

The standby switch is a two position switch. In the standby position mix temperature will be maintained between 32° and 40°F. In the serve position the product temperature in the barrel will be determined by product consistency.

D. Lights Off On Switch

The lights Off On Switch is a two position switch. When the switch is in the ON position the lights will illuminate, when the switch is in the off position the lights will be OFF.



Figure 5. Controls

E. High Pressure Cut Out Switch

The high pressure cut out switch is located under the right side frame about halfway back. Push up to reset.



Figure 6. Disassembling Freezer

3.3. DISASSEMBLY OF FREEZER PARTS

CAUTION

PLACE THE CLEAN OFF ON SWITCH IN THE OFF POSITION BEFORE DISASSEMBLING FOR CLEANING OR SERVICING.

Inspection for worn or broken parts should be made at every disassembly of the freezer for cleaning or other purposes. All worn or broken parts should be replaced to ensure safety to both the operator and the customer and to maintain good freezer performance and a quality product. Frequency of cleaning must comply with the local health regulations.

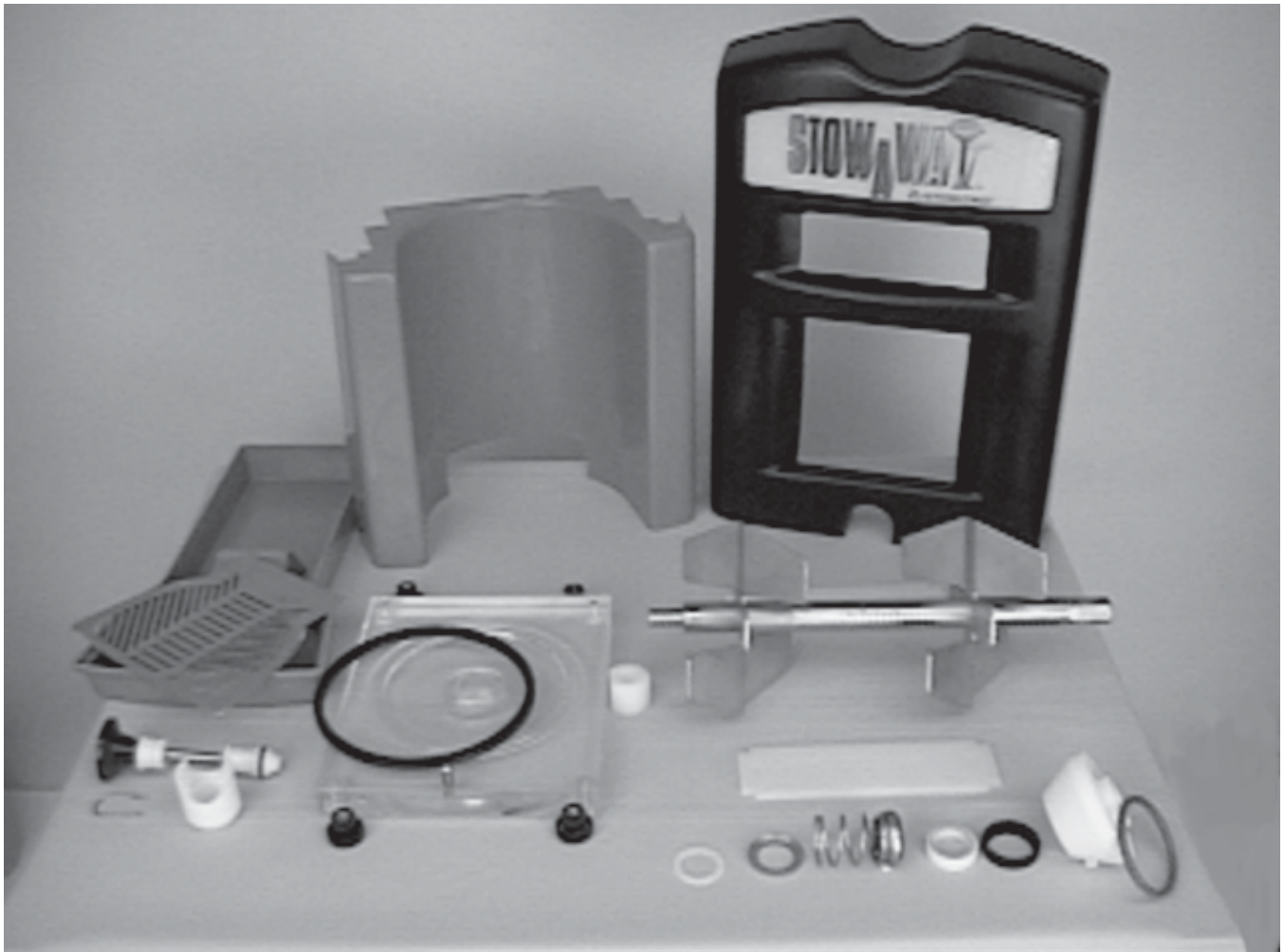

Figure 7. Front Door and Auger Assembly

To disassemble the freezer, refer to the following steps:

- A. Remove the front door by removing the upper and lower plastic shrouds then turn off the knobs, and pull the front door off the studs.
- B. Remove the spigot body from the spout by pulling the horse shoe clip up and out. Then pull the spigot body out of the spout. Disassemble by turning off the black plastic knob and removing all loose pieces.
- C. Pull the agitator assembly out of the freezer barrel.
- D. Keep the rear of the agitator assembly tipped up once it is clear of the freezer barrel to avoid dropping rear seal.
- E. Remove the front agitator support bearing and the two agitator blades.
- F. Remove the rear seal assembly and disassemble.
- G. Wipe socket lubricant from the drive end (rear) of the agitator with a cloth or paper towel.

H. Remove all "O" Rings.

WARNING
DO NOT USE ANY TYPE OF SHARP OBJECT TO REMOVE THE "O" RINGS.

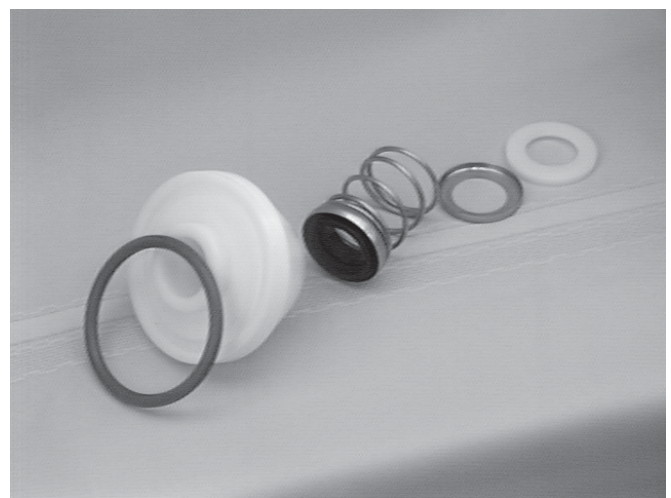

Figure 8. Rear Seal Assembly

3.4 CLEANING THE FREEZER PARTS

Place all loose parts in a pan or container and take to the wash sink for cleaning. To clean freezer parts refer to the following steps:

- A. Place all parts in warm mild detergent water and clean with brushes provided. Rinse all parts with clean hot water.

CAUTION

DO NOT DAMAGE PARTS BY DROPPING OR ROUGH HANDLING.

- B. Wash the freezer barrel and spout with warm detergent water and brushes provided.
- C. The exterior should be kept clean at all times to preserve the lustre of the stainless steel. A mild alkaline cleaner is recommended. Use a soft cloth or sponge to apply the cleaner.
- D. Remove the drip tray and insert. Clean with a soap solution. Rinse with clean hot water.

3.5 SANITIZE FREEZER AND FREEZER PARTS

- A. Use a sanitizer mixed according to manufacturer's instructions to provide a 100 parts per million strength solution. Mix sanitizer in quantities of no less than 2 gallons (7.5 liters) of 120°F water. Allow the sanitizer to contact the surfaces to be sanitized for 5 minutes. Any sanitizer must be used only in accordance with the manufacturer's instructions.
- B. Place all parts in the sanitizing solution, then remove and let air dry.

3.6 ASSEMBLY OF FREEZER

To assemble the freezer parts, refer to the following steps:

NOTE

Petro-Gel sanitary lubricant or equivalent must be used when lubrication of parts is specified.

NOTE

The United States Department of Agriculture and the Food and Drug Administration require that lubricants used on food processing equipment be certified for this use. Use lubricants only in accordance with the manufacturer's instructions.

- A. Assemble all "O" Rings onto parts dry, **without lubrication**. Then apply a thin film of sanitary lubrication to exposed surfaces of the "O" Rings. Apply a thin film of sanitary lubricant on the front of the agitator shaft.
- B. Assemble the rear seal assembly onto the agitator. Be sure the "O" Rings and gaskets are in place before installing the rear seal.

- C. Lubricate the drive end of the agitator (rear) shaft with a small amount of white socket lubricant. A small container of socket lubrication is shipped with the freezer.

- D. Install the two plastic agitator blades onto the agitator. Install front agitator bearing.

- E. Push the auger into the freezer barrel and rotate slowly until the agitator engages the drive.

- F. Assemble and install the spigot body with "O" Rings into the spout. Push straight in until the spigot is in place. Then install the horse shoe clip.

- G. Install door "O" Ring.

- H. Install the front door on the freezer.

- I. Install the knobs on the freezer studs and tighten.

CAUTION

FINGER TIGHTEN THE KNOBS EVENLY. DO NOT OVER-TIGHTEN KNOBS.

Look for the paper seal between the freezer barrel door, "O" Ring, and front door.

3.7 SANITIZING

Sanitizing must be done after the freezer is clean and just before filling with mix. **Sanitizing the night before is not effective.** However, you should always clean the freezer and parts after using it.

WARNING

THE UNITED STATES DEPARTMENT OF AGRICULTURE AND FOOD AND DRUG ADMINISTRATION REQUIRE THAT ALL CLEANING AND SANITIZING SOLUTIONS USED WITH FOOD PROCESSING EQUIPMENT BE CERTIFIED FOR THIS USE. USE "STERA-SHEEN" OR EQUIVALENT.

When sanitizing the freezer, refer to local sanitary regulations for applicable codes and recommended sanitizing products and procedures. The frequency of sanitizing must comply with local health regulations. Mix sanitizer according to manufacturer's instructions to provide a 100 parts per million strength solution. Mix sanitizer in quantities of no less than 2 gallons (7.5 liters) of 120°F water. Allow sanitizer to contact the surfaces to be sanitized for 5 minutes. Any sanitizer must be used only in accordance with the manufacturer's instructions.

NOTE

Stoelting, Inc. has found that STERA-SHEEN GREEN LABEL SANITIZER AND CLEANER does an effective job of properly sanitizing and cleaning a soft serve freezer. We therefore include a sample with each new freezer. For further information read the directions on the packet. Other products may be as effective.

CAUTION
PROLONGED CONTACT OF SANITIZER WITH FREEZER MAY CAUSE CORROSION OF STAINLESS STEEL PARTS.

In general, sanitizing may be conducted as follows:

- A. Prepare 2 gallons (7.5 liters) of sanitizing solution following manufacturer's instructions.
- B. Pour sanitizer into hopper.
- C. Place the CLEAN OFF ON switch in the CLEAN position. Check for leaks around the front door seal.
- D. After five minutes, open spigot to drain sanitizing solution. When solution has drained, place the CLEAN OFF ON switch in the OFF position. Allow the freezer barrel to drain completely.

3.8 INITIAL FREEZE DOWN AND OPERATION

This section covers the recommended operating procedures to be followed for the safe operation of the freezer.

- A. Sanitize just prior to use.
- B. Place the CLEAN OFF ON switch in the OFF position.
- C. Fill the hopper with mix.
- D. Place the CLEAN OFF ON switch in the ON position. The product will be ready to serve in about 20-30 minutes.

3.9 CONSISTENCY ADJUSTMENT

The consistency adjustment knob is located next to the right front leg. Turn clockwise for a thicker product and counterclockwise for a thinner product. Allow 15-30 minutes for the product to change consistency.

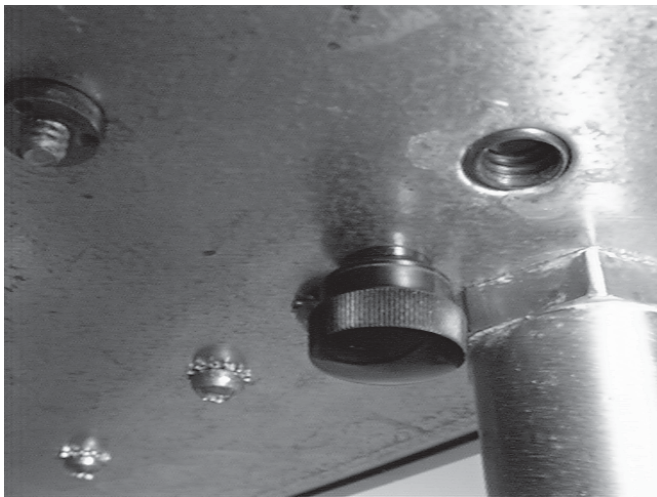

Figure 9. Consistency Control Knob

SECTION 4 BULB REPLACEMENT

4.1 LIGHT BULB REPLACEMENT

1. Remove the upper plastic shroud.
2. Remove the four retaining screws from the electrical panel and tip forward.
3. Grasp faulty bulb and pull out.
4. Push in replacement bulb until it snaps into place.
5. Replace the electrical panel and secure with the four retaining screws.
6. Replace the plastic shroud.

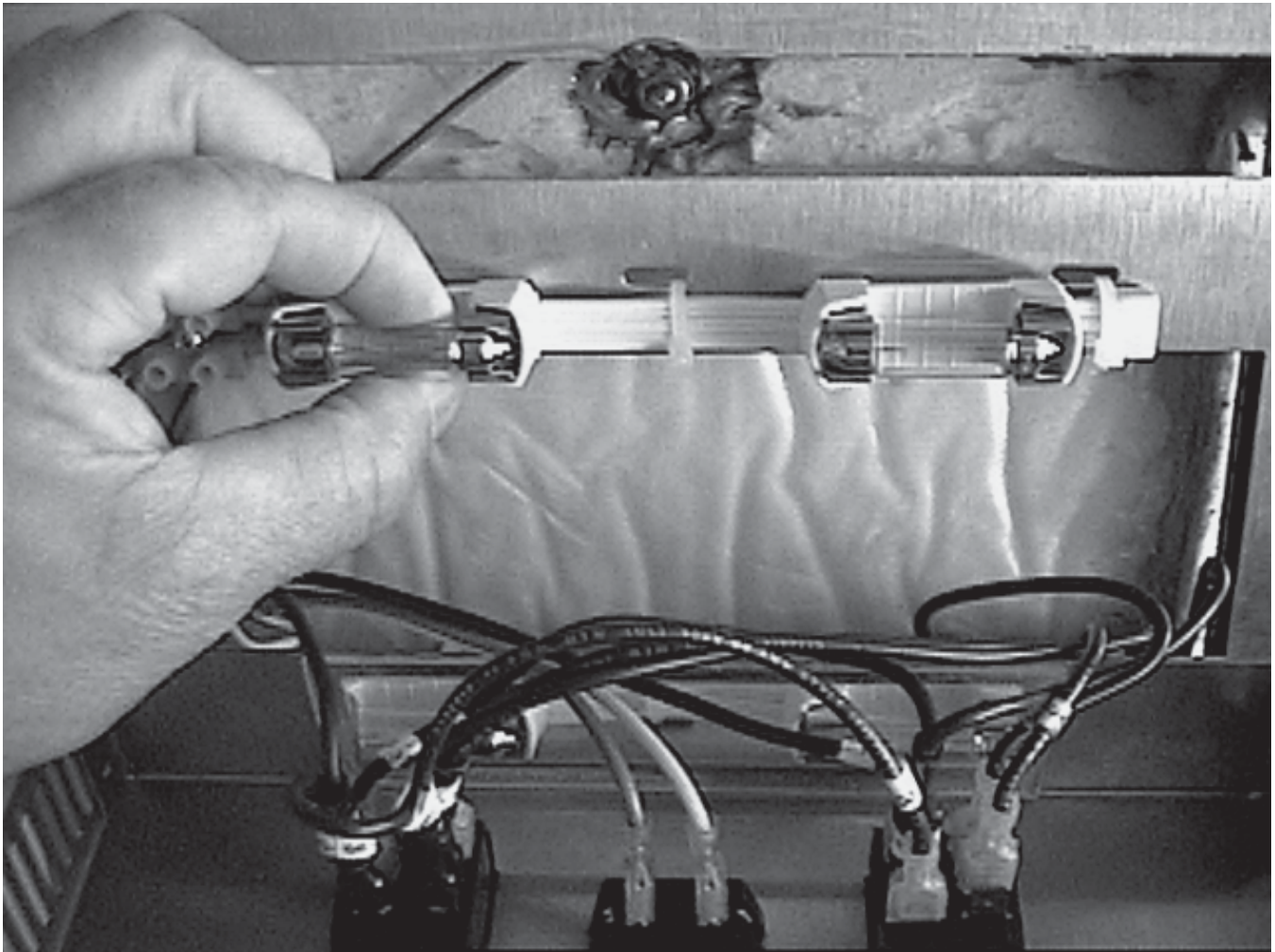

Figure 10. Light Bulb

SECTION 5 REFRIGERATION SYSTEM

5.1 REFRIGERATION SYSTEM

The refrigeration system is a dual purpose system. The system is designed to operate the hopper and the evaporator simultaneously at different temperatures. The system is designed for efficient use with R404A as the refrigerant. The proper charges are indicated on the nameplate. Figure 11.

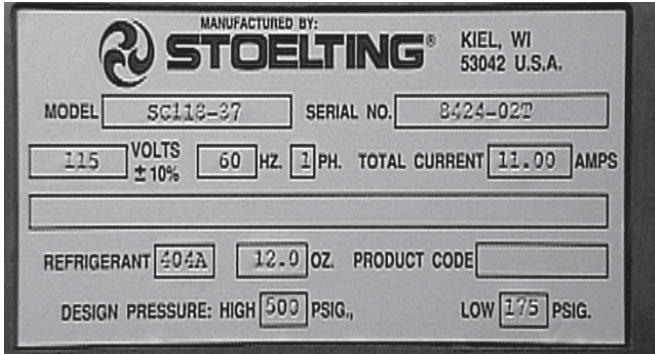

Figure 11. Nameplate

The system has a high pressure cutout set to trip at 470 P.S.I.G. The reset can be accessed from under the right side frame about half way back.



Figure 12. High Pressure Cut Out

5.2 Compressor

The compressor is designed specifically for use with R404A.

A. Winding Test

To test the compressor motor windings for possible problems perform the following steps:

WARNING

DISCONNECT FREEZER FROM ELECTRICAL SUPPLY SOURCE BEFORE SERVICING.

1. Remove the retaining screws from the bottom of the left side panel and slide the side panel out and down.

2. Remove the compressor terminal cover by inserting a standard screw driver under the terminal cover retaining clip and gently pry off. (Fig. 13)

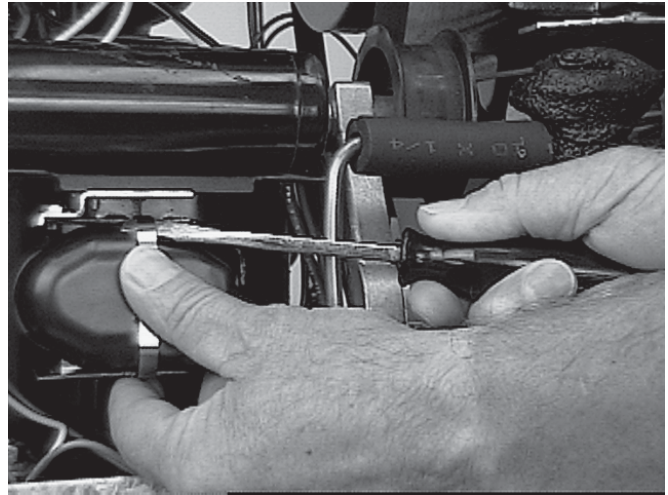

Figure 13. Compressor Terminal Cover Removal

3. Remove the retaining clip and cover.
4. Remove the relay by pulling straight off. Remove the wire from terminal C. (Fig. 14)

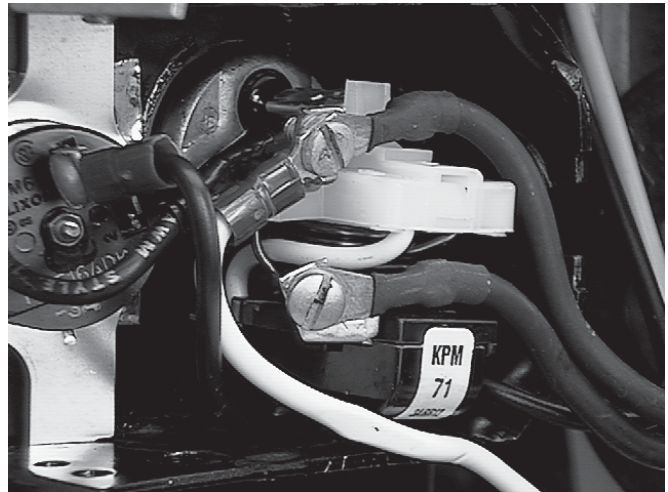

Figure 14. Compressor Connections

NOTE

The following values are for Tecumseh model AE9422ZXA with the compressor at or about room temperature. For other models or brands consult the manufacturer's service data manual.

5. Connect ohmmeter to terminal C and R. Resistance through the run winding should be 1.10 ohms with the ohmmeter set at times one. (Fig. 15)

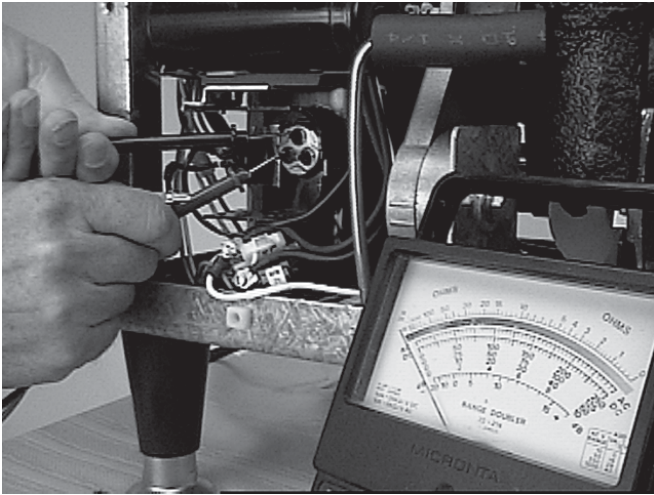

Figure 15. Ohm Meter Connection

6. Connect ohmmeter to terminal C and S. Resistance through the start winding should be 5.94 ohms with the ohmmeter set at times one.
7. To check if windings are shorted to ground connect one ohmmeter lead to a bare metal part on the compressor such as any copper line leading to or from the compressor and checking terminals C, R, and S.

NOTE

The compressor is equipped with an external overload protector. If the compressor trips the overload check for high amperage draw.

5.3 CONDENSERS

The air cooled condenser is a copper tube and aluminum fin type. Condensing is totally dependent on air flow. A plugged condenser or restrictions in the louvered grill will restrict air flow. This will lower the capacity of the system and damage the compressor.

The condenser must be kept clean from dirt and grease. The freezer must have a minimum clearance of 2 - 3" at the rear of the unit for free flow of air. Make sure the freezer is not pulling over 100° F. of air in from other equipment in the area. Figure 16.



Figure 16. Clearance for Air Flow

The condenser filter and condenser require periodic cleaning. To clean refer to the following procedures:

WARNING

DISCONNECT FREEZER FROM ELECTRICAL SOURCE BEFORE SERVICING.

1. To remove the condenser filter, remove the lower front plastic shroud by pulling straight out. Then remove the filter. Visually inspect for dirt. If the filter is dirty, shake or brush excess dirt off the filter and wash in warm soapy water. Once the filter is clean rinse thoroughly in warm, clear water and squeeze dry, taking care not to damage the filter in any way.
2. Remove the retaining screws from the bottom of the right or left side panel and slide the panel out and down. Remove the phillips head screws from the back panel and pull down and out.
3. Visually inspect the condenser for dirt by shining a light through the coil from the back (inside) of the condenser. Figure 17.

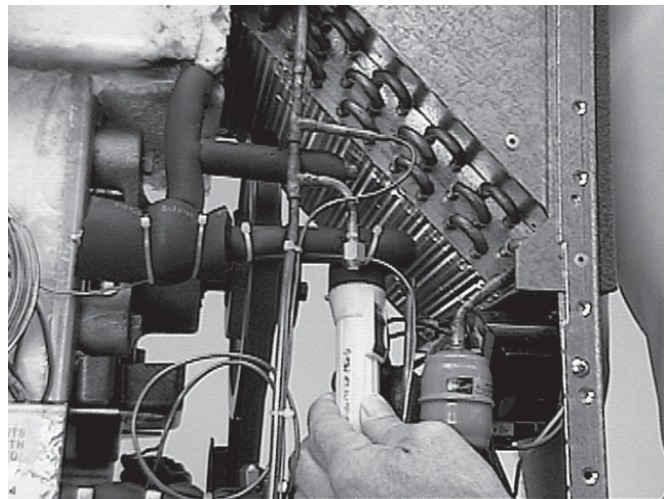

Figure 17. Condenser

4. If the condenser is dirty, place a wet towel over the front inside of the condenser.
5. Using compressed air or CO2 tank, blow out the dirt from the back (outside) of the condenser. Most of the dirt will cling to the wet towel.

An alternative method of cleaning the condenser is to use a condenser brush and vacuum.

NOTE

If the condenser is not kept clean, loss of refrigeration efficiency will result, causing extended run time or soft product consistency.

5.4 EVAPORATOR

An TXV (thermostatic expansion valve) is used to meter the refrigerant to the evaporator. The self regulating TXV is preset at the factory for approximately 45 PSIG at 75°F ambient temperature.

A. TXV Adjustments

To determine whether or not the TXV is in need of adjustment, perform the following procedure:

WARNING
DISCONNECT FREEZER FROM ELECTRICAL SOURCE BEFORE SERVICING.

1. Remove the retaining screws from the bottom of the left and right side panels and slide the panels out and down.
2. Remove the cap from the low side schrader valve and install a 0 - 100 PSIG gauge. Figure 18.

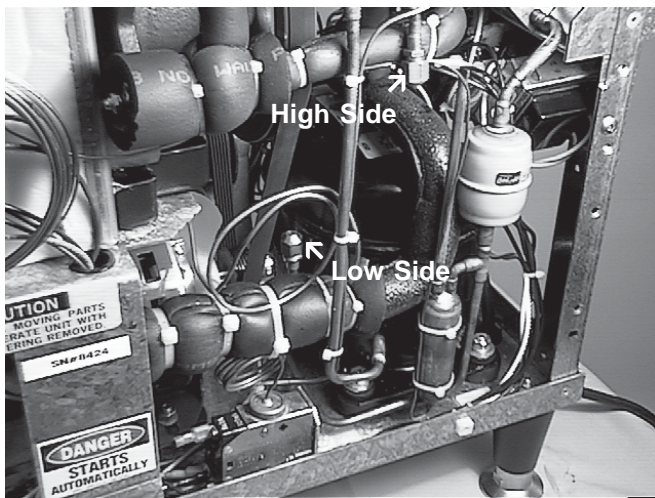

Figure 18. Access Ports

3. Plug the freezer in, start the refrigeration cycle and read the pressure.
4. The proper gauge reading should be approximately 45 PSIG at 75°F. (21.1°C) Ambient temperature at the end of pull down. If the readings are not within these parameters continue with the following steps:

NOTE

Before performing the following procedures be absolutely certain it is necessary to adjust the TXV.

5. Remove the cap on the TXV and using a service wrench, turn the valve stem 1/4 (90°) turn counter clockwise for more cooling or clockwise for less cooling. Figure 19.



Figure 19. TXV

6. Should the readings not reach 45 PSIG repeat step #7 until the correct reading is obtained.
7. Once the 45 PSIG reading is obtained, replace the cap on the TXV, remove the pressure gauge and replace the low side schrader valve cap.

B. TXV Removal

CAUTION
IF THE TXV IS REPLACED THE HEAT SINK (WET CLOTH) MUST BE USED TO PREVENT DAMAGE TO THE VALVE.

WARNING
DISCONNECT FREEZER FROM ELECTRICAL SOURCE OF SUPPLY BEFORE SERVICING.

1. Assuming the left and right side panels are removed, perform the following procedures for removing the TXV.
2. Remove the bulb from the suction line exiting from the evaporator.
3. Recover refrigerant charge and leave a port open to prevent pressure buildup during TXV removal.
4. Remove any insulation from the TXV and the immediate surrounding lines.
5. Remove or push back any foam insulation from surrounding lines.
6. Apply a heat sink (wet cloth) to the valve dome. Figure 20.
7. Unsweat the suction line and liquid line from the TXV and remove the TXV with heat sink.

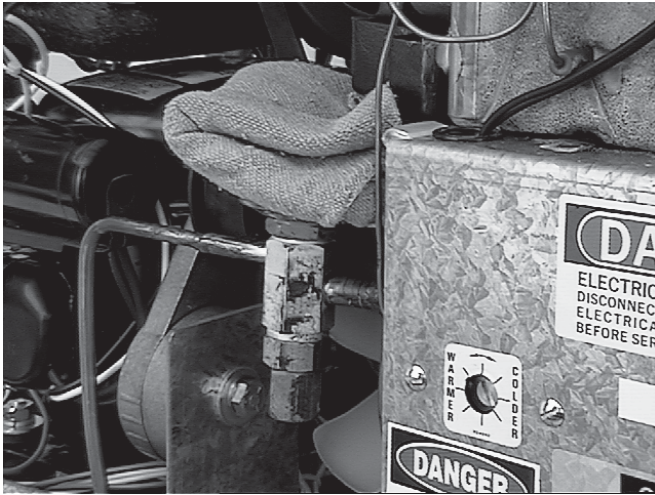

Figure 20. Heat Sink

C. TXV Replacement

To replace the TXV perform the following procedures:

CAUTION

WHEN REPLACING THE TXV A HEAT SINK (WET CLOTH) MUST BE USED TO PREVENT DAMAGE TO THE VALVE.

1. Position the TXV with the heat sink so the liquid and suction line correspond with the proper valve ports.
2. With an open port braze the liquid line and suction line to the TXV using the appropriate brazing material.
3. Remove the heat sink from the TXV.
4. Replace foam insulation to the surrounding lines.
5. Replace any insulation to the TXV and immediate surrounding areas.
6. Install bulb on suction line exiting the evaporator.

NOTE

The TXV bulb should always be mounted on the top of the horizontal line with the capillary end facing the flow of refrigerant. Good contact between the bulb and suction line is necessary for proper operation of the valve. The bulb must also be well insulated.

7. Purge and evacuate the system.
8. Break the vacuum to 0 PSIG with dry nitrogen, then open an access port.
9. Remove the dryer by unsweating the refrigeration lines then with an open port sweat in the replacement dryer. Make certain the arrow points in the direction of flow. Figure 21.

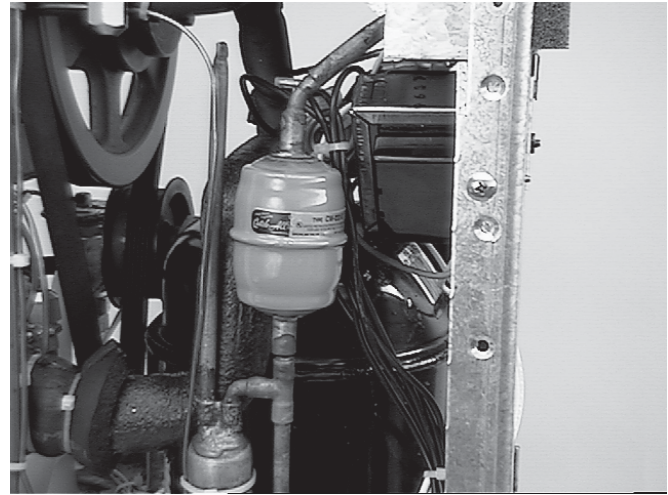

Figure 21. Drier

10. Triple evacuate the system. Evacuate twice to 1500 microns of mercury, break in the vacuum each time with dry nitrogen. Then evacuate to 500 microns of mercury.

11. Recharge the system to nameplate specifications and leak test.

5.5 HOPPER

A parallel refrigeration circuit feeds the hopper. A capillary tube is used to meter the refrigerant to the hopper. An E.P.R. valve (Evaporator Pressure Regulating) is used to control the refrigerant at the outlet. The E.P.R. controls the hopper pressure so, during heavy dispensing periods, hopper temperatures will not drop and freeze the mix in the hopper. The adjustable E.P.R. valve is preset at the factory. If the hopper temperature is too cold or too warm, an E.P.R. valve adjustment may be necessary.

A. E.P.R. Valve Adjustment

To adjust the E.P.R. valve, refer to the following procedures:

1. Remove the phillips head screws from the bottom of the right side panel and remove the side panel by sliding out and down.
2. Remove the cap from the E.P.R. schrader valve. Figure 22.

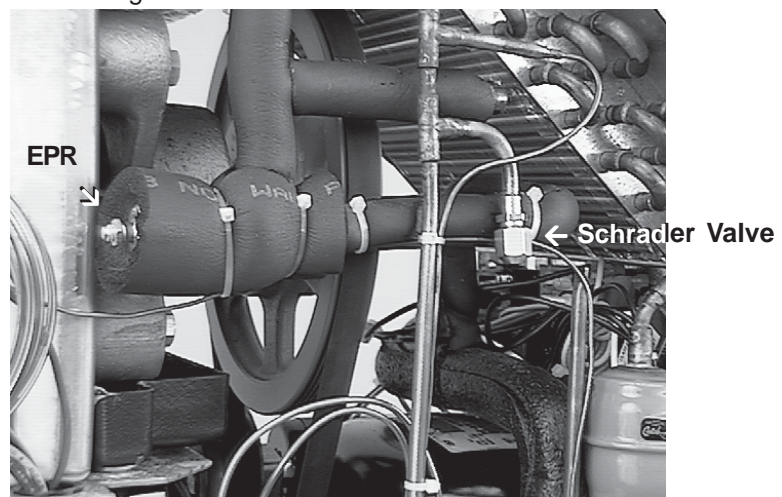

Figure 22. EPR and Schrader Valve

3. Install a 0-100 P.S.I.G. gauge onto the E.P.R. schrader valve.
4. Start the refrigeration cycle and read the pressure.

NOTE

The ideal E.P.R. valve setting (69-71 PSIG) will not allow mix to freeze to the walls of the hopper.

5. If the pressure gauge reading does not fall between 69-71 PSIG parameters, proceed with the following steps:
6. Loosen the lock nut on the E.P.R. valve and using a small screwdriver, turn the valve stem 1/4 (90°) turn counter clockwise for more cooling or clockwise for less cooling. Figure 23.

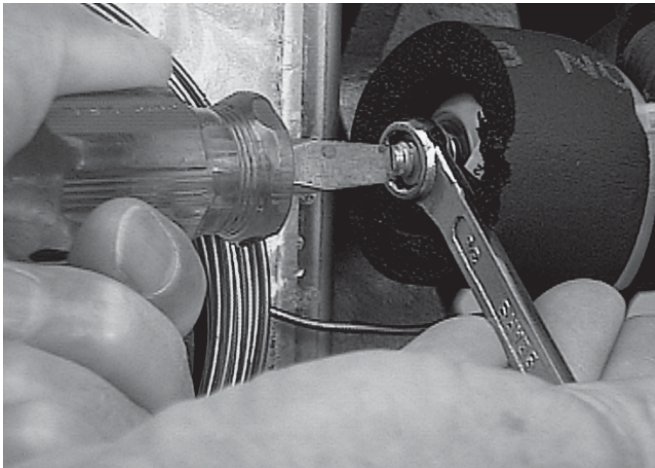

Figure 23. EPR Valve Adjustment

7. Allow the system to level out for 3 - 5 minutes before taking another pressure reading.
8. Should the reading still not fall between 69-71 PSIG, repeat steps 6 and 7 until the correct reading is obtained.
9. Once the 69-71 PSIG reading is obtained, tighten the locknut snugly, remove the pressure gauge and replace the E.P.R. schrader valve cap.
10. Replace the side panel.

B. E.P.R. Removal

CAUTION

IF THE E.P.R. VALVE IS REPLACED THE HEAT SINK (WET CLOTH) MUST BE USED TO PREVENT DAMAGE TO THE VALVE.

1. Assuming the right side panel is removed for adjusting the E.P.R. valve, perform the following procedures for removing the E.P.R. valve.

WARNING

DISCONNECT THE FREEZER FROM ELECTRICAL SUPPLY SOURCE BEFORE SERVICING.

2. Recover refrigerant charge and leave the port open to prevent pressure build-up during E.P.R. valve removal.
3. Remove foam rubber insulation from the surrounding lines.
4. Apply a heat sink (wet cloth) to the E.P.R. valve.

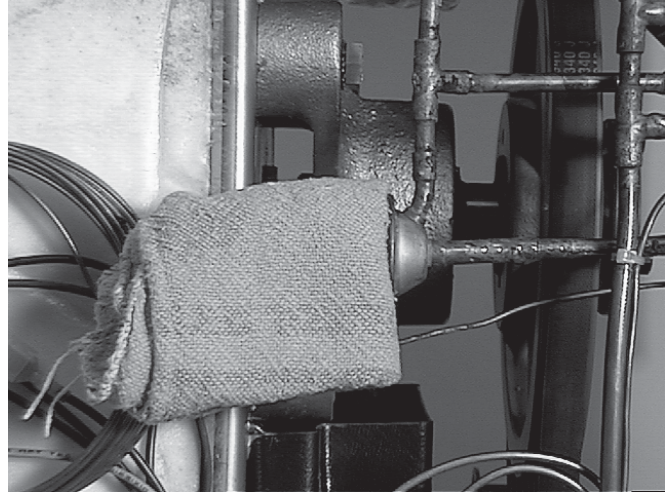

Figure 24. EPR Heat Sink

5. Unsweat the hopper evaporator line and the line leading to the low side of the main system from the E.P.R. valve.
6. Remove the E.P.R. valve with the heat sink.

C. E.P.R. Replacement

CAUTION

IF THE E.P.R. VALVE IS REPLACED THE HEAT SINK (WET CLOTH) MUST BE USED TO PREVENT DAMAGE TO THE VALVE.

1. Position the E.P.R. valve with the heat sink, so the hopper evaporator outlet line and the line leading to the low side of the main system correspond with the proper ports.
2. With an open port braze the lines to the E.P.R. valve using the appropriate brazing material.
3. Remove the heat sink from the E.P.R. valve.
4. Replace any foam insulation to the surrounding lines.
5. Purge and evacuate the system.

6. Break the vacuum to 0 PSIG with dry nitrogen, then open an access port.
7. Remove the dryer by unsweating the refrigeration lines then with an open port sweat in the replacement dryer. Make certain the arrow points in the direction of flow. Figure 25.

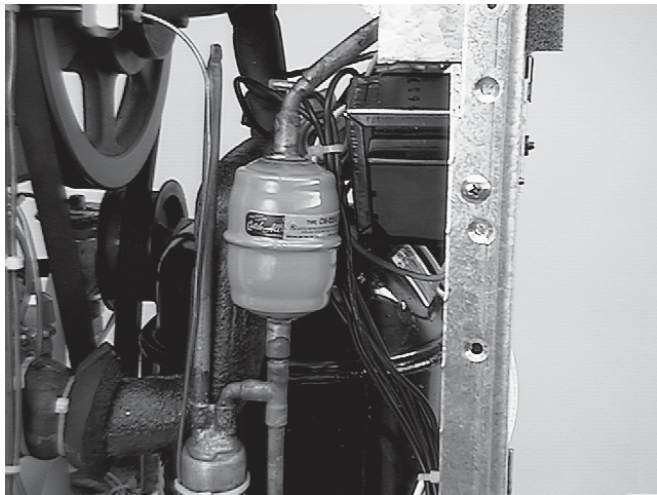

Figure 25. Filter Drier

8. Triple evacuate the system, evacuate twice to 1500 microns of mercury, break in the vacuum each time with dry nitrogen, then evacuate to 500 microns of mercury.
9. Recharge the system to the nameplate specifications and leak test.

5.6 CAPILLARY TUBE

Capillary tube replacement may be necessary if the correct hopper cooling cannot be obtained.

A. Capillary Tube Removal

WARNING

DISCONNECT FREEZER FROM ELECTRICAL SUPPLY SOURCE BEFORE SERVICING.

1. Remove the retaining screws from the bottom of the right side panel and pull the side panel out and down.
2. Recover refrigerant charge and leave a port open to prevent pressure build-up during capillary tube dryer assembly removal.
3. Unsweat capillary tube dryer assembly at the dryer inlet and at the hopper inlet located at the side of the hopper. Figure 26.

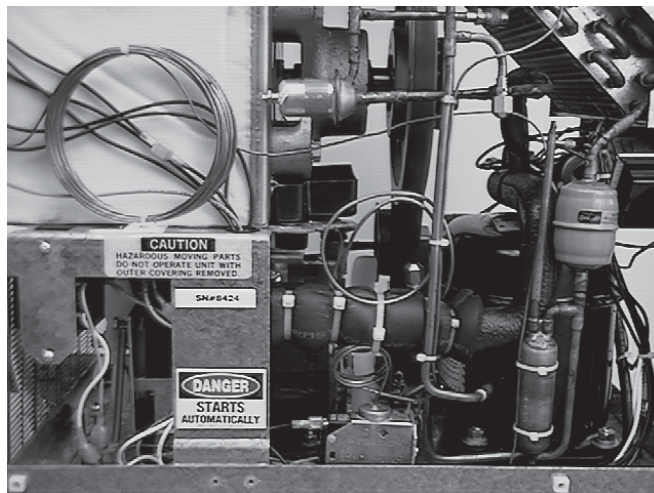

Figure 26. Drier Cap. Tube Assembly

NOTE

Before unsweating the capillary tube at the hopper inlet it will be necessary to remove the foam insulation from the capillary tube at that connection.

4. Remove the capillary tube dryer assembly.

B. Capillary Tube Replacement

1. Position the capillary tube dryer assembly so the large diameter tube is in position to be brazed first using the appropriate brazing material.
2. Position the smaller diameter tube at the side of the hopper and braze the tube to the hopper inlet using the appropriate brazing material.
3. Replace the foam insulation to the hopper inlet connections.
4. Purge and evacuate the system.
5. Break the vacuum to 0 PSIG with dry nitrogen, then open an access port.
6. Remove the dryer by unsweating the refrigeration lines then with an open port sweat in the replacement dryer. Make sure the arrow points in the direction of flow.
7. Triple evacuate the system. Evacuate twice to 1500 microns of mercury, break in the vacuum each time with dry nitrogen. Then evacuate to 500 microns of mercury.
8. Recharge the system to nameplate specifications and leak test.

5.7 HIGH PRESSURE CUTOUT SWITCH

A. Pressure Switch Removal

WARNING

DISCONNECT FREEZER FROM ELECTRICAL SUPPLY SOURCE BEFORE SERVICING.

1. Remove the retaining screws from the bottom of the right side panel and pull the side panel out and down.
2. Recover the refrigeration charge and leave a port open to prevent pressure build-up during pressure switch removal.
3. Remove foam rubber insulation from the area where the capillary tube is sweated into the "T".
4. Cut the plastic tie straps holding the capillary tube. Then unsweat the capillary tube from the "T". Figure 27.

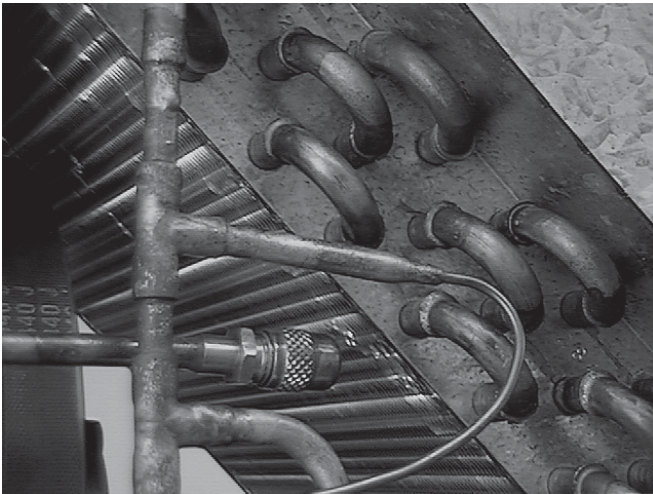

Figure 27. Pressure Switch "T"

5. Remove the two electrical wires from the switch. Figure 28.

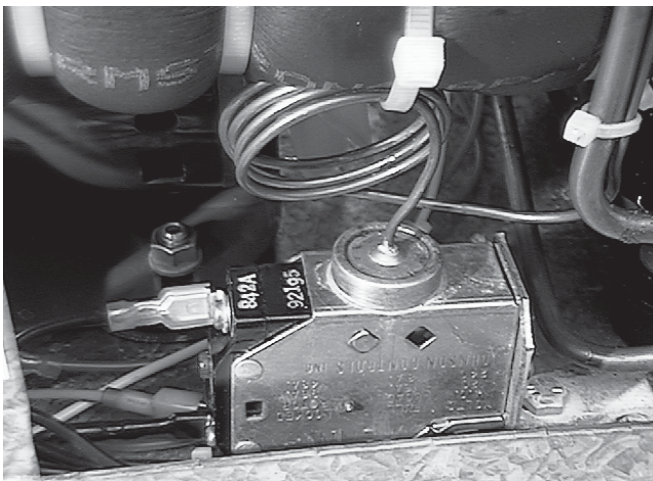

Figure 28. Pressure Switch

6. Remove the two retaining screws holding the switch to the bracket and remove the switch.

B. Pressure Switch Replacement

1. Position the replacement switch on the bracket and secure with the two retaining screws.
2. Install the two electrical wires.
3. Position the capillary tube in the "T" and braze using the appropriate brazing material.
4. Position and tie the capillary tube to the 1/4" line with plastic tie straps.
5. Replace the foam rubber insulation.
6. Purge and evacuate the system.
7. Break the vacuum to 0 PSIG with dry nitrogen, then open an access port.
8. Remove the dryer by unsweating the refrigeration lines then with an open port sweat in the replacement dryer. Make sure the arrow points in the direction of flow.
9. Triple evacuate the system. Evacuate twice to 1500 microns of mercury, break in the vacuum each time with dry nitrogen. Then evacuate to 500 microns of mercury.
10. Recharge the system to nameplate specifications and leak test.

SECTION 6 SEQUENCE OF OPERATIONS

6.1 LIGHTS

On/Off light switch is independent of all other switches. When on, the light transformer is operational and the lights illuminate.

6.2 SWITCHES

<u>On/Off/Clean Switch Position</u>	<u>Mode Switch Position</u>	<u>Sequence of Operations</u>
Clean	Serve or Standby	-Drive Motor and Condenser Fan Motor start and run together, No time limit exists. -Power Transformer, torque switch, compressor, liquid level control, and mix low light are non-operational.
On	Serve	-Drive Motor and Condenser Fan start and run together continuously. -Power Transformer is on. -Liquid level control and mix low light are operational. -With liquid mix or loose slush in the freezing cylinder, the torque switch is closed. The delay-on-make timer starts the compressor after a 10-30 second delay. -When the slush reaches consistency, the torque switch opens and the compressor immediately shuts off. The drive motor and condenser fan motor continue to run.
On	Standby	-Power transformer, liquid level control and mix low light are operational only when the temperature control is closed. -Drive motor, condenser fan motor, and compressor cycle on and off with the temperature control (compressor start delays 10-30 seconds).

NOTE

If the temperature control is set too cold, control will default to the torque switch to prevent freeze-up.

6.3 SAFETY SWITCH

Door Switch - If the front door is removed, the freezer will not function.

Motor Internal Thermostat - If the motor overheats, the freezer will not function.

Warning - The motor internal thermostat automatically resets as the motor cools. The freezer will automatically restart. Disconnect freezer from power source for servicing.

High Pressure Cutout Switch - If the compressor discharge pressure exceeds 470 PSIG, the freezer will not function.

SECTION 7 ELECTRICAL

7.1 ELECTRICAL

The control system operates from drive motor torque. When the product in the barrel freezes it puts a greater load on the drive motor. As the resistance builds up the drive motor body begins to rotate in the opposite direction of the motor shaft overcoming spring tension. When the motor has rotated far enough it contacts a microswitch shutting off the compressor. After time has passed or some product has been drawn the resistance in the barrel decreases and the spring pulls the motor back. The micro switch then closes and the compressor starts. There is a 10-30 second time delay on the compressor start. The drive motor and condenser fan runs continuously.

7.2 FRONT ELECTRICAL PANEL

The front electrical panel contains the CLEAN-OFF-ON switch, mode switch, light switch, and mix low light. The panel also covers the lights that illuminate the sign and front door.

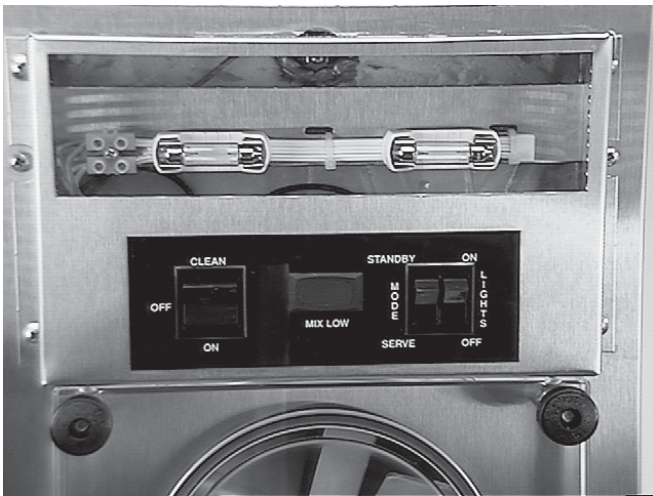

Figure 29. Electrical Panel

To replace electrical components perform the following procedures:

A. Switch and Indicator

1. Remove the upper plastic shroud by lifting up and out.
2. Remove the four retaining screws from the electrical panel and tip forward. Figure 29.
3. Identify and disconnect the wires from the switch or indicator.
4. Squeeze the four plastic retainers together and push out through the hole. Figure 30.

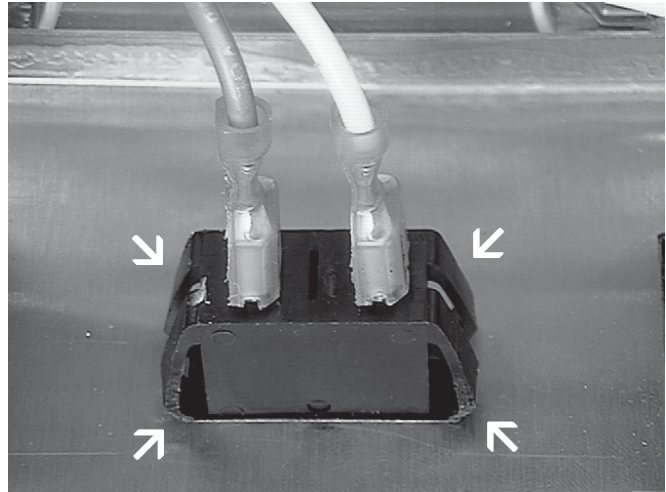

Figure 30. Switch/Indicator Removal

5. Push the replacement switch through the hole and reconnect the wires.
6. Replace the electrical panel and secure with the four retaining screws.
7. Replace the plastic shroud.

B. Light Bulb

1. Remove the upper plastic shroud.
2. Remove the four retaining screws from the electrical panel and tip forward.
3. Grasp faulty bulb and pull out. Figure 31.

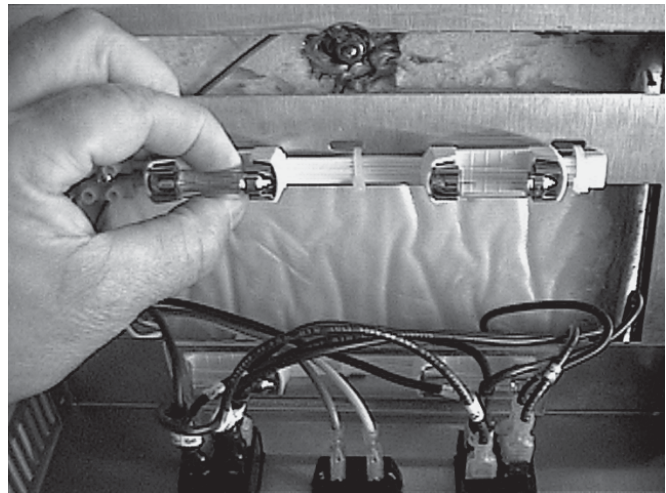

Figure 31. Light Bulb Replacement

4. Push in replacement bulb until it snaps into place.
5. Replace the electrical panel and secure with the four retaining screws.
6. Replace the plastic shroud.

7.3 REAR ELECTRICAL PANEL

The rear electrical panel contains a 24 volt transformer, contactor, and time delay. To replace the electrical components perform the following procedures:

A. Electrical Panel

1. Remove the retaining screws from the bottom of the left and right side panel and slide the panels out and down.
2. Remove the retaining screws from the top and bottom of the back panel and pull the panel out and down.
3. Remove the two retaining screws from the electrical panel and remove the panel. Figure 32.

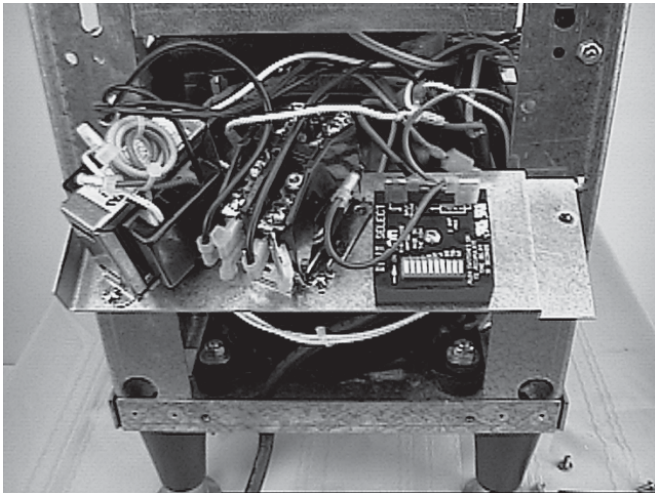

Figure 32. Rear Electrical Panel

4. Replace faulty component.
5. Relocate electrical panel and secure with the two retaining screws.
6. Replace the rear and side panels and secure with the retaining screws.

Assuming the electrical panel is removed perform the following procedures, to replace the electrical components:

B. 24 Volt Transformer

1. Disconnect the four wires.
2. Remove the two retaining screws, and remove transformer.
3. Terminate the wires on the replacement transformer per the wiring diagram.
4. Locate and secure the replacement transformer with the two retaining screws.
5. Reconnect the four wires.

C. Contactor

1. Identify and remove the six wires.
2. Remove the two retaining screws and remove the contactor.
3. Remove the four dummy insulated space type connectors and install on the replacement contactor.
4. Locate and secure the replacement contactor with the two retaining screws.
5. Reconnect the four wires.

D. Time Delay Relay

1. Identify and remove the two wires.
2. Remove the retaining screw and remove the relay.
3. Program the replacement relay with the first four dip switches closed.
4. Locate and secure the replacement relay with the retaining screw.
5. Reconnect the two wires.

WARNING

ALL REPAIRS MUST BE COMPLETED AND ALL PANELS REPLACED BEFORE CONNECTING THE FREEZER TO THE ELECTRICAL POWER. THE REMAINING ELECTRICAL COMPONENTS CAN BE REPLACED BY PERFORMING THE FOLLOWING PROCEDURES:

E. Temperature Control

1. Remove the retaining screws from the bottom of the left side panel and slide the panel out and down.
2. Remove the temperature sensing probe by pulling straight out. Figure 33.
3. Remove the two retaining screws from the temperature control and remove the two wires.
4. Connect the two wires to the replacement control.
5. Locate the control and secure with the two retaining screws.
6. Form the replacement temperature sensing probe to match the one removed and push into the well.
7. Adjust temperature control to 11 o'clock (mid-range).

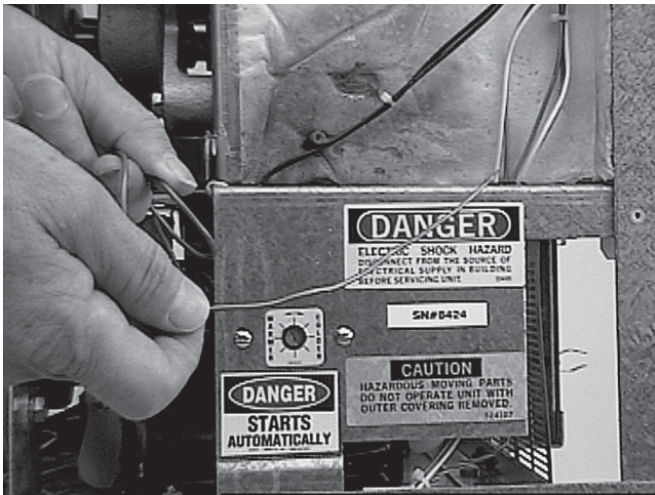

Figure 33. Temperature Control

F. Transformer

1. Remove the retaining screws from the bottom of the right side panel and slide out and down.
2. Remove the two retaining screws from the transformer. Figure 34.
3. Identify and disconnect the four wires.

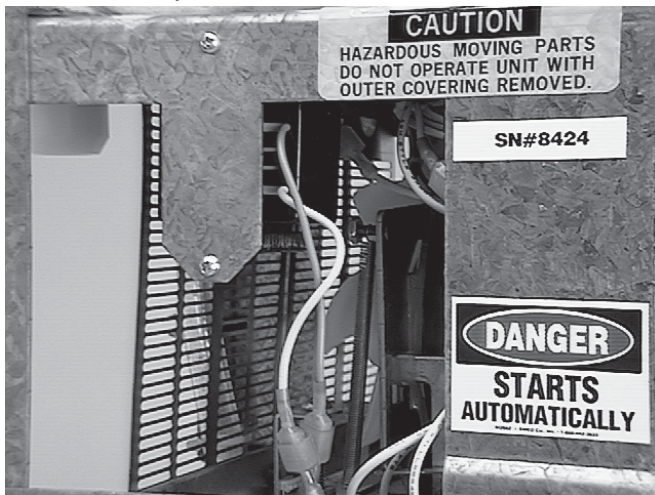

Figure 34. Transformer

4. Connect the four wires to the replacement transformer.
5. Secure with the two retaining screws.

G. Safety Switch

1. Remove the retaining screws from the bottom of the right side panel and slide out and down.
2. Remove the two retaining screws from the switch bracket and lift the assembly out. Figure 35.
3. Remove the two wires from the switch and remove the switch from the bracket.

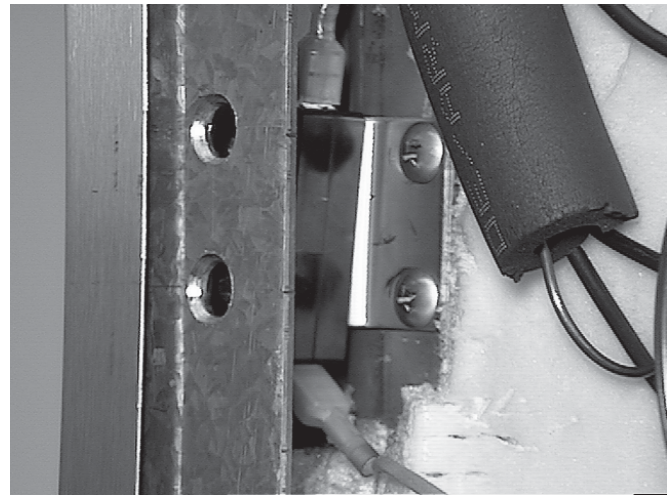

Figure 35. Safety Switch

4. Locate and secure the replacement switch to the bracket.
5. Connect the two wires.
6. Locate switch assembly in the freezer and secure with the two retaining screws.

NOTE

On earlier models the front sheet metal may have to be removed to access the safety switch.

H. Torque Switch

1. Remove the retaining screws from the bottom of the right side panel and slide out and down.
2. Identify and remove the three wires from the switch.
3. Remove the two retaining screws holding the switch bracket to the floor pan. The screws can be accessed from under the floor pan. Figure 36.

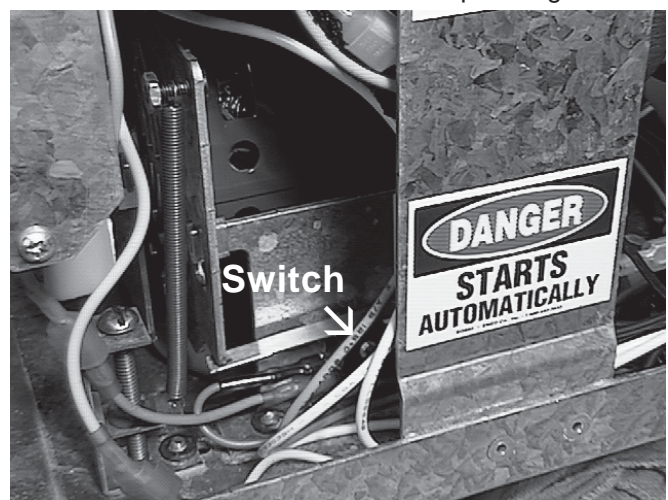

Figure 36. Torque Switch

4. Remove the failed switch from the bracket.

5. Locate the replacement switch onto the bracket and secure.
6. Locate the switch and bracket assembly in the freezer and secure with the two retaining screws.
7. Connect the three wires.

I. Liquid Level Control (Low Mix Light)

1. Remove the lower front plastic panel by pulling straight out.
2. Remove the retaining screws from the bottom and top of the slotted lower left innerfront panel and remove the panel.
3. Identify and remove the five wires from the front row of spade connectors then remove the blue wire from the back row of spade connectors. Figure 37.

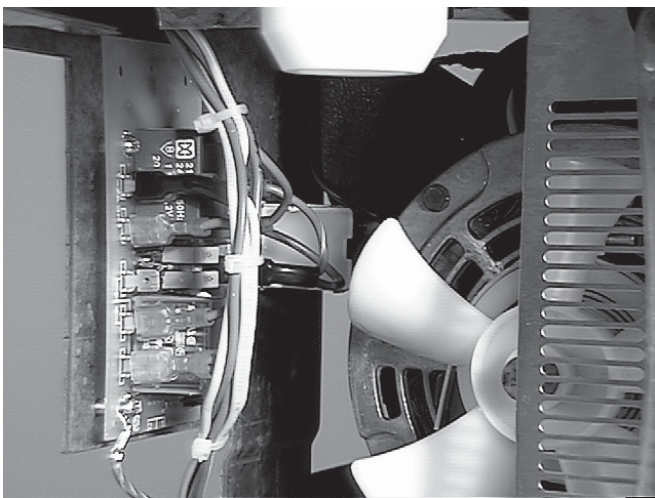

Figure 37. Liquid Level Control

4. Remove the four retaining screws and ground wires.
5. Remove the failed control and transfer the remaining wires to the replacement control.
6. Locate and secure the replacement control in the freezer. Take care to insure the ground wires are replaced properly or the control will not work.
7. Replace the remaining wires.

7.4 MAJOR COMPONENT REPLACEMENT

Prepare for component removal. The procedures in this section must be followed completely in the order in which they appear. To remove any or all of the major components of the freezer, the following steps must be performed first.

WARNING
DISCONNECT FREEZER FROM ELECTRICAL SOURCE BEFORE SERVICING.

1. Remove the retaining screws from the side panels, back panel, and rear top panel then remove panels.
2. To replace the drive motor you must also remove the lower front plastic panel and the two inner slotted panels.

A. Condenser Fan Motor Replacement

1. Identify the three wires and disconnect.
2. Cut the necessary tie straps.
3. Remove the four retaining nuts and washers.

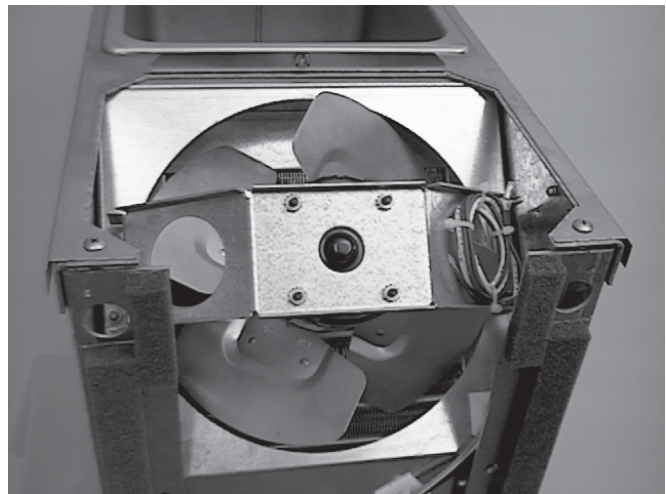

Figure 38. Condenser Fan Motor

4. Remove the assembly from the freezer, and remove the fan blade and fan bracket.

NOTE

Take a measurement of the fan blade position on the shaft on the failed motor and position it in the same place on the replacement motor shaft and secure. Install the fan bracket onto the replacement fan motor and secure.

5. Locate the fan assembly into the freezer and secure with the four retaining nuts and washers.
6. Properly terminate and reconnect the three wires and secure the wires with plastic tie straps.

B. Condenser Replacement

1. Recover the refrigerant charge and leave a port open to prevent pressure build-up during condenser replacement.
2. Unsweat the two refrigerant lines. Then cover exposed refrigerant lines to protect them from debris while preparing the condenser for removal.

3. Remove the two retaining screws from the electrical panel below the condenser and remove the panel.
4. Drill out the four blind rivets holding the condenser to the freezer frame and the two rivets holding the shroud to the condenser frame. Figure 39.

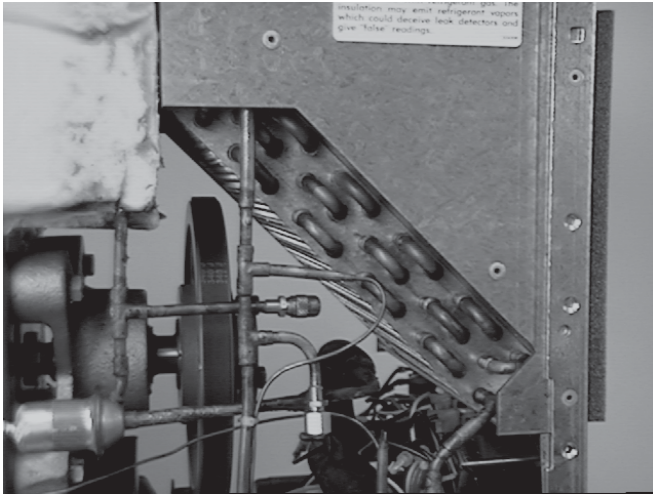

Figure 39. Condenser

5. Remove the condenser.
6. Install the replacement condenser, and position the condenser and shroud to align the four holes. Then secure with the 3/16" blind rivets or 3/16" screws, nuts, and washers. It is not necessary to replace the rivet holding the shroud to the condenser.
7. Braze the two refrigerant lines to the condenser.
8. Purge and evacuate the system.
9. Break the vacuum to 0 PSIG with dry nitrogen then open an access port.
10. Remove the dryer by unsweating the refrigeration lines then with an open port sweat in the replacement dryer. Make certain the arrow points in the direction of flow.
11. Triple evacuate the system. Evacuate twice to 1500 microns of mercury, break in the vacuum each time with dry nitrogen. Then evacuate to 500 microns of mercury.
12. Recharge the system to nameplate specifications and leak test.
13. Locate and secure the rear electrical panel with the two screws.

C. Compressor Replacement

1. Remove the compressor terminal cover by inserting a screwdriver under the terminal cover retaining clip and gently pry off, then remove clip and cover.
2. Identify and remove the white and black supply wires. Figure 40.

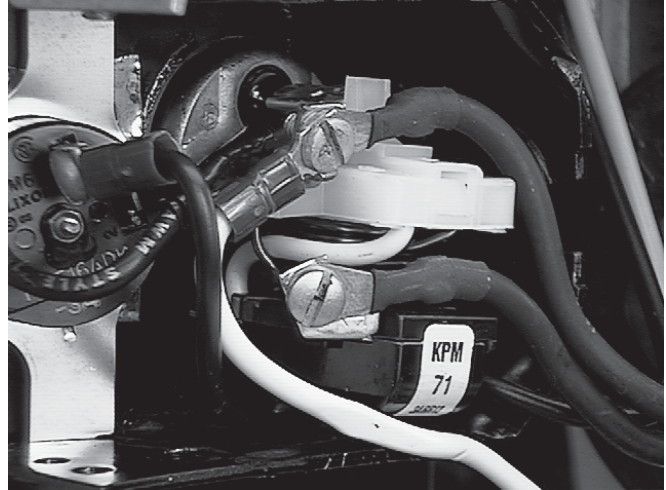

Figure 40. Electrical Wires

3. Remove the four nuts, washers, and bolts holding the compressor to the frame. Figure 41.

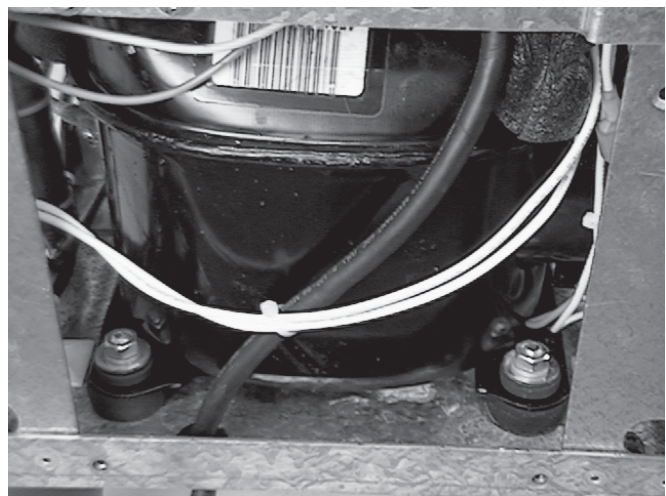

Figure 41. Compressor

4. Recover the refrigerant charge and leave a port open to prevent pressure build-up during compressor replacement.
5. Remove and/or protect insulation that may be contacted by flame or extreme heat, then unsweat the discharge and suction line.
6. Remove the compressor through the left side of the freezer.
7. Remove the four rubber compressor mounts from the failed compressor.

NOTE

Rubber mounts are not always furnished with replacement compressors.

8. Check the compressor for a burn out condition using an acid test kit. If acid is found, clean out the system per the compressor manufacturers instructions.
9. Plug all open ports of the failed compressor.

NOTE

A compressor returned to the company with any open ports will void the warranty. Always plug any open ports on a compressor that has been removed.

10. Install the four rubber mounts on the replacement compressor.
11. Install the replacement compressor into the freezer and secure with the four bolts, washers and nuts.
12. Remove the cap plugs from the replacement compressor and with an open port braze the suction and discharge lines to the compressor.
13. Connect the black wire to the overload and the white wire to the relay. Then install the cover and retaining clip.
14. Purge and evacuate the system.
15. Break the vacuum to 0 PSIG with dry nitrogen, and open an access port.
16. Remove the dryer by unsweating the refrigeration lines and then with an open port sweat in the replacement dryer. Make certain the arrow points in the direction of the flow.
17. Triple evacuate the system. Evacuate twice to 1500 microns of mercury, break in the vacuum each time with dry nitrogen. Then evacuate to 500 microns of mercury.
18. Recharge the system to nameplate specifications.
19. Leak test and replace insulation.

D. Drive Motor Replacement

1. Follow the electrical wires from the motor and disconnect at the spade connectors.
2. Disconnect the ground wire.
3. Disconnect the torque spring by removing the nut on the motor bracket and sliding off. Figure 42.



Figure 42. Torque Spring

4. Remove the three cap screws from the stiffener bracket and remove the bracket. Figure 43.

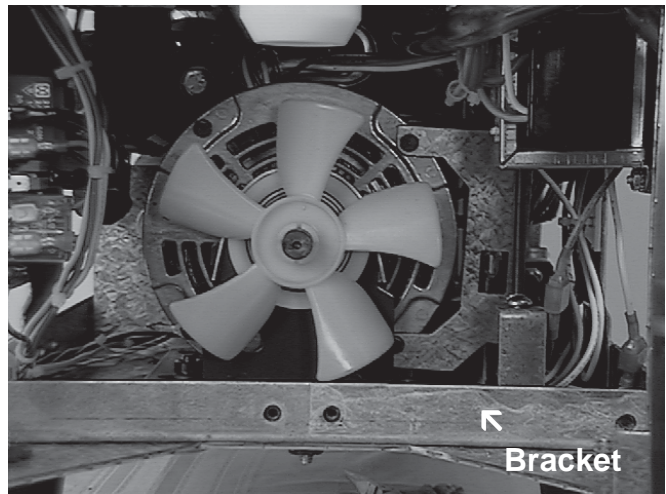

Figure 43. Drive Motor/Stiffener Bracket

5. Pull back belt tensioner and remove belt. Figure 44.

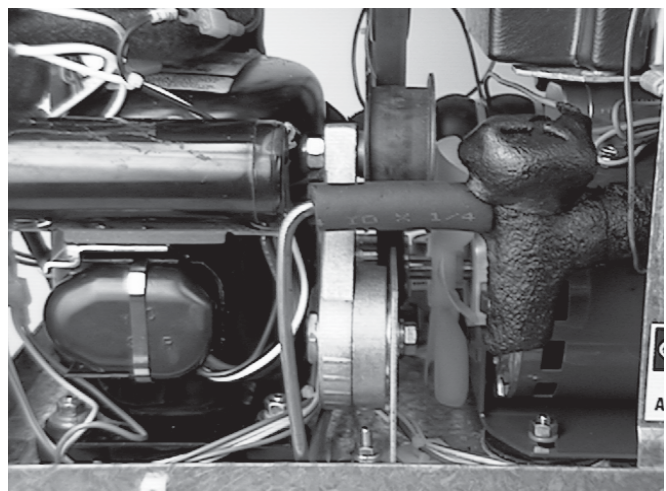

Figure 44. Belt Tensioner

6. Remove the four retaining bolts, nuts and washers.

7. Slide the motor out through the front.
8. Measure the position of the pulley and fans before removing.
9. Remove the pulley, fans, and bracket, then install on the replacement motor in the same position.
10. Locate the replacement motor in the freezer with the rubber pads in place over the mounting holes.
11. Secure the motor with the four bolts, nuts, and washers.
12. Pull back the belt tensioner and install belt. Check for proper alignment.
13. Install torque spring onto bracket and replace nut.
14. Locate stiffener bracket and secure with the four cap screws.
15. Connect the electrical wires. Do not overlook the ground wire, it must be connected.

If the belt tensioner needs adjustment perform the following procedures:

- a. With idler loosely snug against mounting bracket, rotate idler until belt is contacted.
- b. With a wrench on large idler nut, rotate idler into belt until indicator mark (single mark on idler half against mounting bracket) aligns with first mark closest to indicator mark (3 - 4.5 lbs. of tension).
- c. Tighten cap screw to lock idler into position.

E. Bearing Assembly Replacement

1. Remove the agitator assembly from the barrel.
2. Pull back the belt tensioner and remove the belt.
3. Remove the four retaining bolts and washers, then remove the bearing and pulley assembly through the left side of the freezer. Figure 45.

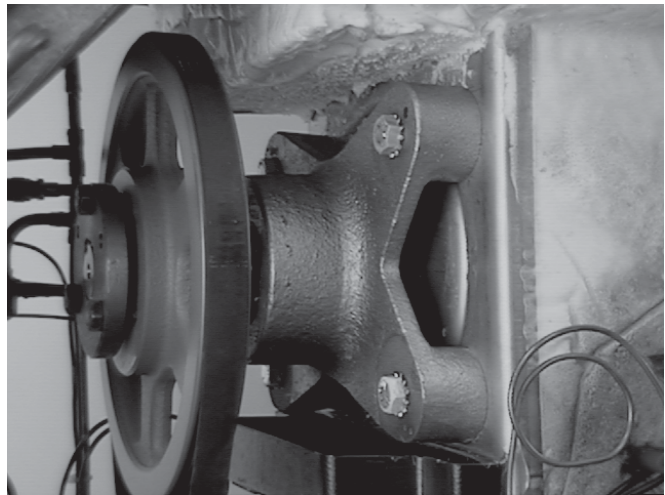

Figure 45. Bearing Assembly

4. Measure the position of the pulley hub, then remove by removing the three cap bolts and turning two of the bolts in the threaded holes to separate the hub from the pulley.
5. Install the pulley on the replacement part and securely tighten the three bolts.
6. Locate the pulley bearing assembly on the barrel and secure with the four retaining bolts and washers. Pull back the belt tensioner and install the belt. Check for proper alignment.

SECTION 8 TROUBLESHOOTING

PROBLEM:	CAUSE	CORRECTION
High Pressure Cutout Switch Tripped.	Restricted air flow to condenser.	Remove restriction.
	Condenser fan not running.	Check for obstruction or damage.
	Dirty condenser.	Clean condenser
Drive motor overload trips. (Freezer shuts down when running)	Improper Brix reading.	Refill with product that has Brix reading between 11 and 13.
	Low voltage.	Check power supply
Product dispenses incorrectly.	No mix in product cylinder or low mix in hopper.	Keep product cylinder and hopper full.
	Scraper blade missing from agitator.	Replace scraper blade.
	Freezer is being overdrawn.	Slow down rate of draw.
Product is too thin.	Toggel switch in OFF or CLEAN position.	Place toggel switch in ON position.
	Ambient temperature is about 100°F (37.7°C).	Move or direct hot air away from freezer.
	Freezer is being overdrawn.	Slow down the rate of draw.
	Condenser is dirty.	Clean condenser.
Agitator Does Not Rotate	Drive motor overload tripped off.	Turn freezer off for 5 minutes, allow automatic reset.
	Agitator stuck or frozen.	Thaw product in freezer if frozen.
	No power to drive motor.	Check wire harness and switches in drive circuit and repair or replace.
	Drive motor is defective.	Check and replace if necessary.
No Ice Crystals on Initial Freeze Down	Blown fuse in building or no input power to freezer.	Check for blown fuse or input power to freezer.
	Mix too rich.	Take "Brix" reading. Fill with properly mixed product.
	Restricted air flow to freezer.	Air enters lower front and discharges out the top back, make certain both areas are clear.
	Consistency set for too thin a product.	Set consistency to a thicker product.
Spigot Leaking or Stuck.	Spigot "O" rings defective or missing.	Drain mix to below spigot level. Remove spigot, clean, replace "O" rings as needed, lubricate and install.
	Dried mix in spigot assembly.	Drain mix to below spigot level. Remove spigot retainer and spigot. Disassemble and clean with hot water and brush. Lubricate, re-assemble and install. Fill with liquid mix.

SECTION 9 PARTS LIST & DRAWINGS

4171820-SV	Hopper & Evap. Assy. (Ser. #0-9994)
4172889	Back Panel (Ser. #0-9994)
4172948	Auger
4177157	Back Panel (Ser. #10,005 Plus)
4177158-SV	Hopper & Evap. Assy. (Ser. #10,005 Plus)
3170878	Bearing Housing Assy.
3172953	R.H. - Side Panel
3172954	L.H. - Side Panel
3177114	Front Panel
3177121-SV	Front Door w/Pin (Ser. #10,005 Plus)
3172964-SV	Front Door w/Pin (Ser. #0-9994)
2171834	Spigot Assy.
2172898	Front Lower Slotted Panel
2177040	Spigot Extension
2177123-SV	Light Strip (Top) (Ser. #10,005 Plus)
2177160	Air Blockoff Panel
2172939	Probe Assy.
2172966-02SV	2 Light Strip (Sides) (Ser. #0-9994)
2172966-03SV	3 Light Strip (Top) (Ser. #0-9994)
1106373	Spline Lubricant
1120918	Splash Defelctor - Spigot Body
1170836-SV	Limit Switch - Door Safety
1170836-TC	Limit Switch - Torque Consistency
1170882	Auger Bushing
1172926	Drip Tray Grid
718768	Hi Pressure Limit Control Switch
718886	Rocker Switch - Clean/Off/On
718887	Rocker Switch - Serve/Standby, Lights On/Off
739543	Timer Delay
744142	Transformer
744269	Drain Tray
756085	1/2" I.D. Tubing - Drain Tube (Per Foot)
762410	Expansion Valve
762978	EPR Valve
771004	Window - Front
771005	Window - Lower
618488	Relay Overload - Comp.
618530	Relay - Comp.
624607	O-Ring - Spigot Body
624857	O-Ring - Rear Seal
625311	Quad Ring - Front Door
647512	Screw - Vent Cover
647653	Panel Screw - Back Panel/Front Slotted Panels
649000-39	Panel Screw - Side Panels
667830	V-Ring Seal - Brg. Hsg. Assy.
667860	Shaft Seal - Brg. Hsg. Assy.
667892	Rear Seal
694400	Spring - Spigot Body
695763	Spring - Torque Consistency Adjustment
696130	Lock Clip - Spigot Body

508135	Petro-Gel 4 oz. tube
513556	Owner's Manual
521227	Vent Cover (Ser. #0-9994)
521228	Hopper Cover
521229	Drip Tray
521230	Splash Panel
521231	Header Panel
521232	Vent Cover (Ser.#10,005 Plus)
522418	Motor - 1/3 HP
522833	Fan Motor - Condenser
598012	Pulley - Motor
598331	Pulley - Bearing Assy.
430168	Power Cord - 15 Amp.
454016	Idler
458104	Indicator Light - Mix Out
482004	Knob - Torque Consistency Adjustment
482024	Knob - Spigot Body
482043	Knob - Front Door
490725	Leg
490730	Non-Skid Pad - Leg
493063	Incandescent Light Bulb - 24V/5 Watt (Ser. #0-9994)
493064	Incandescent Light Bult - 24V/10 Watt (Ser. #10,005 Plus)
324014	Decal - Black Arrow on White
324105	Decal - Caution Elec. Shock
324107	Decal - Caution Moving Parts
324113	Decal - Caution Grounded Plug
324141	Decal - Caution Rotating Blades
324208	Decal - Refrig. Leak Check
324242	Decal - Temp. Adjustment
324566	Decal - Wired According to
324676	Decal - Switches
324677	Decal - Stowaway
324686	Decal - Danger Starts Automatic
324689	Decal - Seal Assy.
342006	Drier - Main
342020	Drier - Cap. Tube
368140	Condenser Filter
208401	Brush 1" x 3" x 10"
230624	Start Capacitor - Comp.
231105	Cap. Tube
232002	Retaining Cap. - Spigot Body
264061	Jaw Type Clamp - Drain Tube
282022-SV	Compressor - Tecumseh (w/caps)
284081	Condenser
295011	Contactora
296179	Liquid Level Control
296658	Temperature Control
146353	Bearing - Brg. Housing Assy.
146449	Bearing - Drive Motor
152227	V-Belt
162051	Fan Blade - 6" (rear)
162052	Fan Blade - 5" (front)
162067	Fan Blade - Condenser
162156	Scraper Blade

ITEM	STOELTING PN	QTY	DESCRIPTION
1	5114-101	1	PLUG & O-RING RETAINER
2	1120918	1	SPLASH DEFLECTOR
3	694400	1	SPRING COMP 3X.281X13/32
4	232002	1	RETAINER CAP
5	482024	1	KNOB 1-27/32 PLASTIC BLACK
6	2171830	1	SPIGOT SHAFT
7	M820302	.001	ADHESIVE, RESIWELD A
8	M820303	.001	ADHESIVE, RESIWELD B
9	624607	1	RING O 11/16X7/8X3/32 SPECIAL

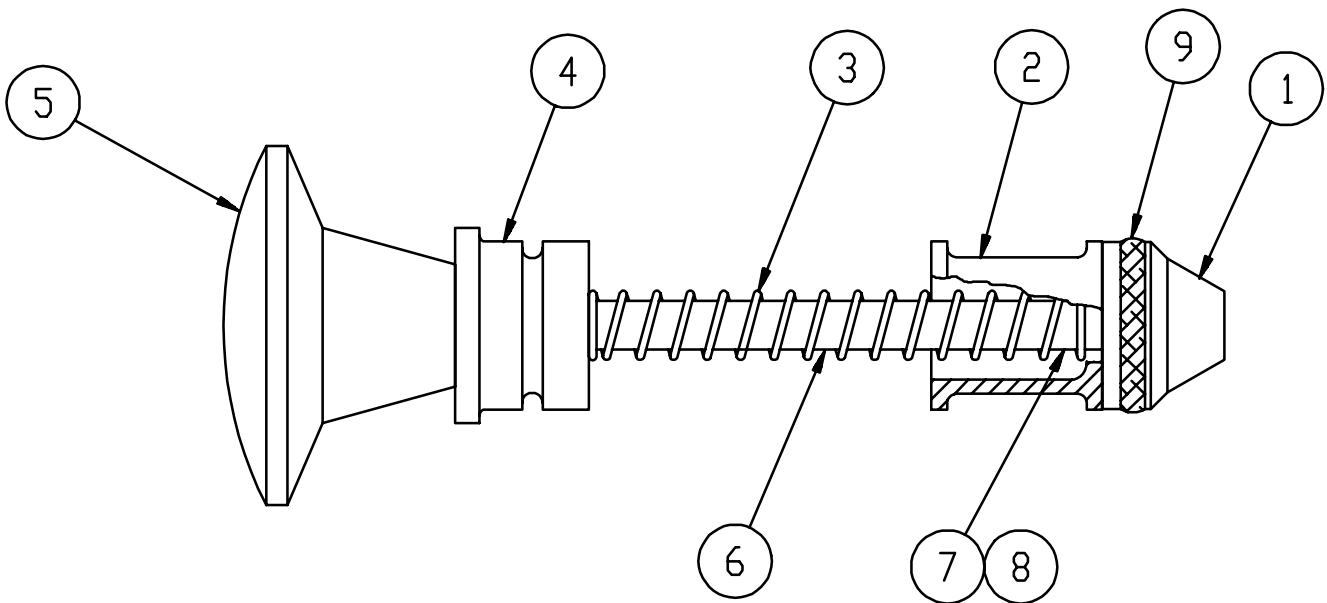

ITEM	STOELTING PN	QTY	DESCRIPTION
1	4171833	1	FAN SHROUD
2	766948	4	WASHER SHAKEPROOF 10 ZINC
3	538297	4	NUT HEX FULL 10-24 ZP
4	3171831	1	BRACKET, CONDENSER FAN
5	766940	4	WASHER SHAKEPROOF 8 ZINC PLATE
6	538280	4	NUT HEX 8-32X11/32X1/8 STL
7	522833	1	MOTOR, FAN
8	162067	1	BLADE FAN 9IN DIA 4-BLADES
9	284081	1	CONDENSER
10	628032	2	RIVET C'SUNK 3/16'DIA.ALUMINUM
11	766430	2	WASHER #8
12	2177026	1	FAN GUARD
13	222997	1	BUSHING SNAP 9/32 ID, 3/8 HOLE
14	M820172	00	LOCTITE (BLUE)

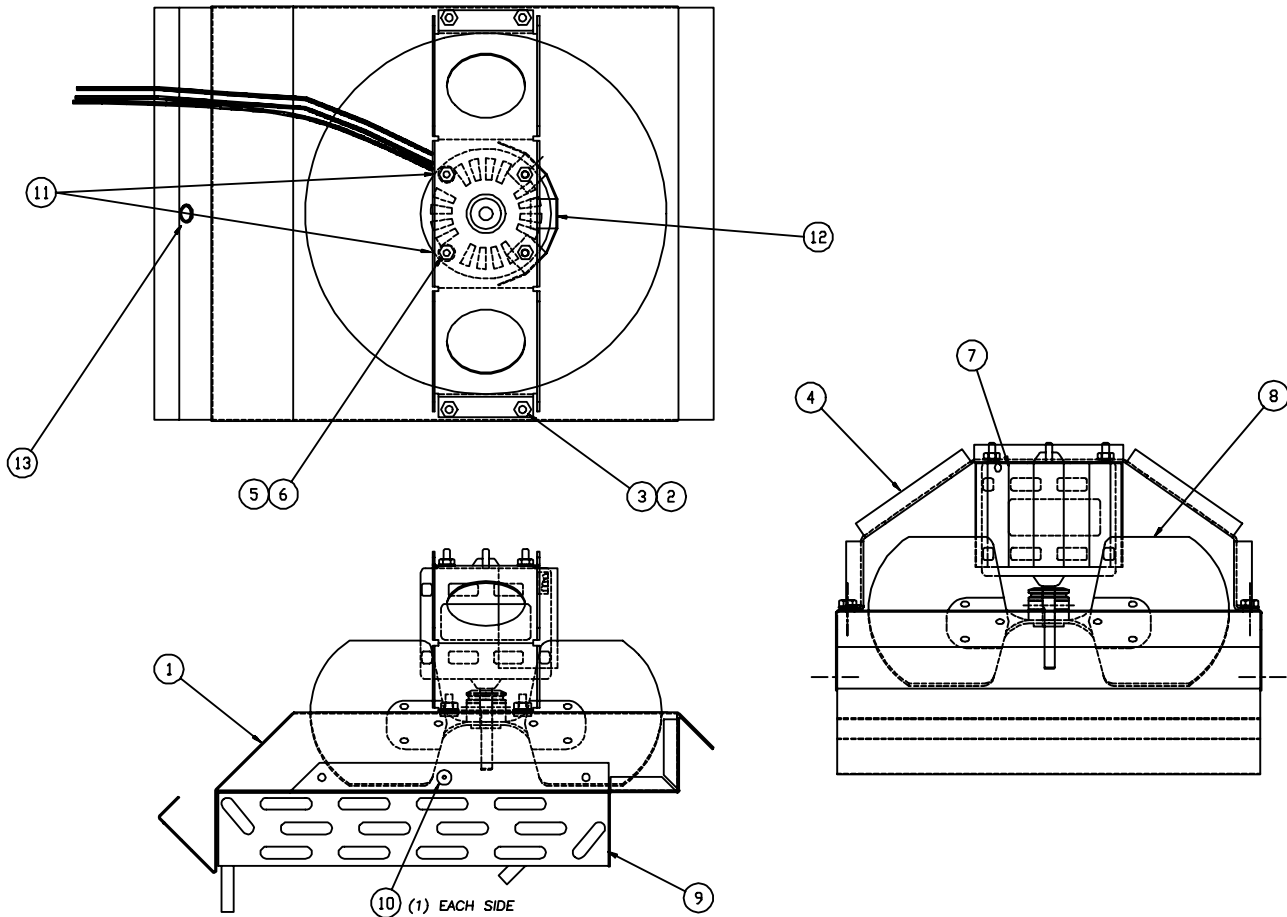

ITEM	STOELTING PN	QTY	DESCRIPTION
1	3172952	1	FRONT PANEL
2	2172966-02	2	2 LIGHT STRIP W/ CAP & TERMINAL
3	2172966-03	1	3 LIGHT STRIP W/ CAP & TERMINAL
4	647416	3	SCREW MACH 6-32 X 5/8 RD HD PH
5	739040	4	TIE 8.0 LG X 1/8 WIDE NEUTRAL
6	584200-13	1	PLUG HOLE 1.00 DIA MTG HOLE
7	1170836	1	LIMIT SWITCH ASSEMBLY
8	766933	2	WASHER SHAKEPROOF 6X5/16
9	647432	2	SCREW MACH 6-32 X 7/8 PAN HD PH

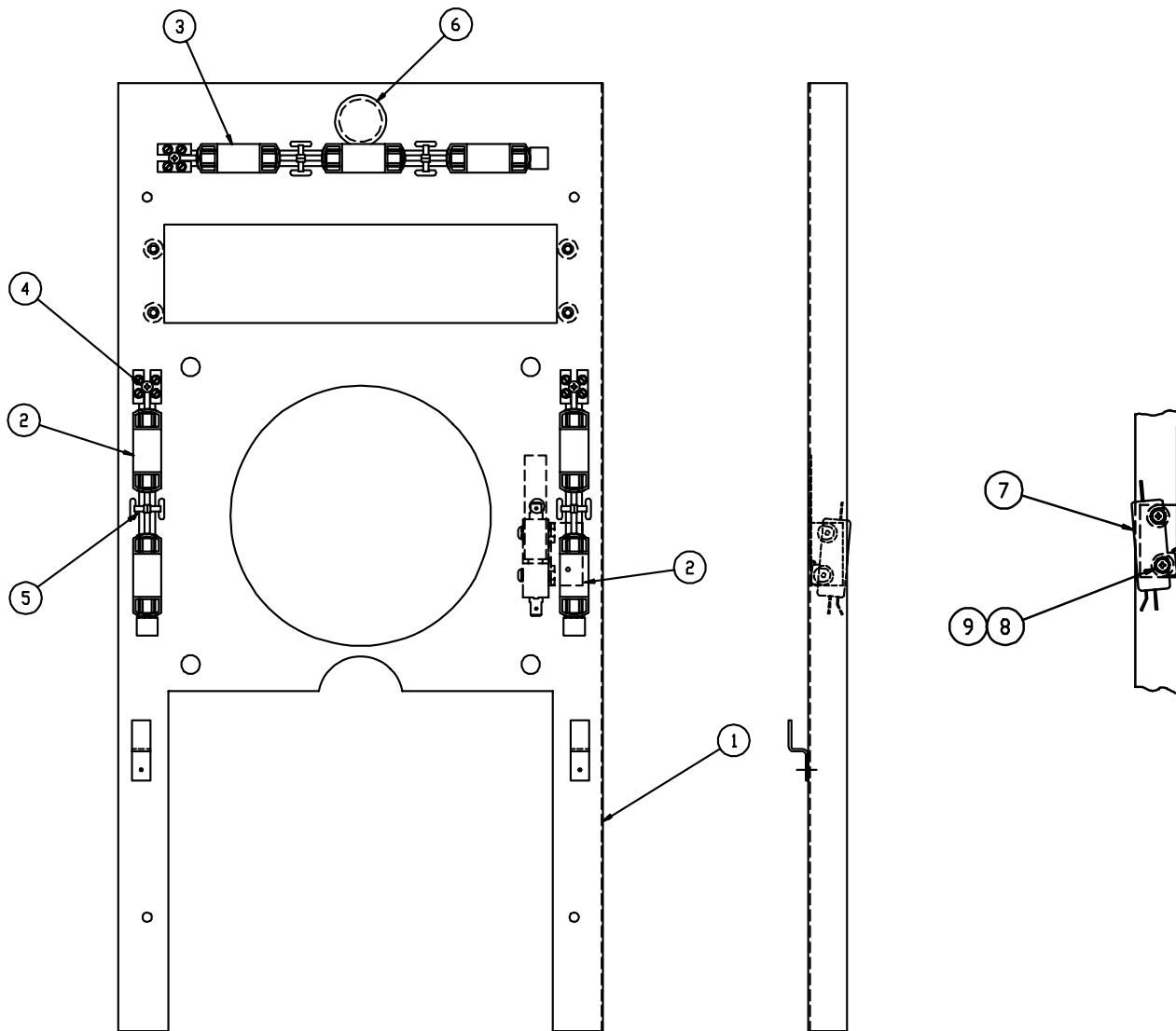

ITEM	STOELTING PN	QTY	DESCRIPTION
1	3177173	1	PANEL, RIGHT SIDE
2	.	1	MODEL ID PLATE
3	4177157	1	PANEL, BACK
4	647653	2	SCREW MACH 10-24 X 3/8 TRS HD
5	324107	3	DECAL, CAUTION MOVING PARTS
6	3177174	1	PANEL, LEFT SIDE
7	324113	1	DECAL CAUTION GROUNDED PLUG
8	647512	2	SCREW MACH 8-32 X 3/8 PAN HD
9	521232	1	COVER, VENT SC118-37
10	130000	1	BAG, ENVELOPE FRONT LOADING
11	324566	1	DECAL - WIRED ACCORDING TO
12	.	1	WIRING DIAGRAM
13	701007	4	STANDOFF, SCREW GROMMET #10
14	739040	1	TIE 8.0 LG X 1/8 WIDE NEUTRAL
15	723529	1	TAG CAUTION
16	521231	1	PANEL, HEADER C118-37H
17	521230	1	PANEL, SPLASH C118-37H
18	324677	1	DECAL, HEADER C118-37H
19	647886	4	SCREW MACH 1/4-20 X 1/2 TRS HD
20	2177179	2	SPACER, DRINK MIX ASSY.
21	649000-39	4	SCREW MACH 10-24 X 3/4 TRS HD ST
22	728088	.95 FT	TAPE INSULATION 1/2X1X33FT
23	368140	1	CONDENSER FILTER
24	2177040	1	SPIGOT EXTENSION
25	324689	1	DECAL-REAR SEAL ASSEMBLY
26	422074	2	GROMMET RUBBER BLACK

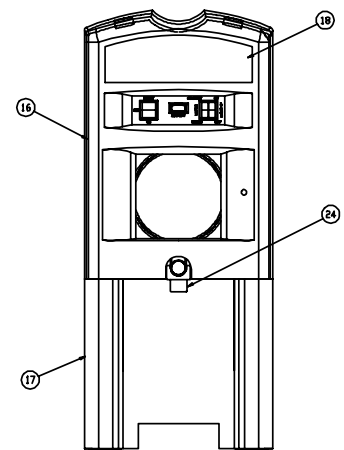
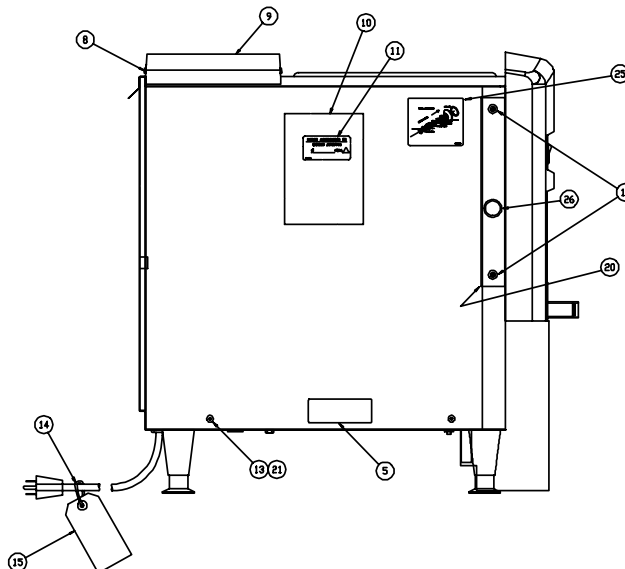
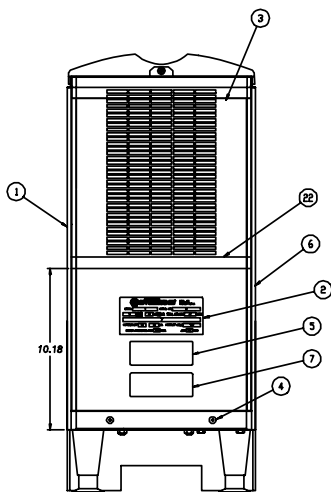
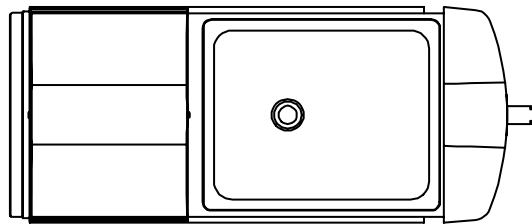

27	324107	3	DECAL CAUTION MOVING PARTS
28	324105	2	DECAL CAUTION-ELECT SHOCK
29	2172928	1	STIFFENER BRACKET
30	644093	3	SCREW CAP 1/4-20 X 1/2 HX HD
31	1170892	1	AUGER BUSHING
32	625311	1	RING QUAD 5.75 ID, 50 DURD
33	324141	1	DECAL CAUTION-ROTATING BLADES
34	493064	4	LIGHT INCANDESCENT, 24V, 10 WATT
35	482043	4	KNOB, 1/4-20 FEMALE W/ THRU HOLE
36	3177121	1	FRONT DOOR ASSY
37			
38	324208	2	DECAL REFRIG LEAK CHECK
39	3172887	1	PANEL, TOP
40	647653	10	SCREW MACH 10-24 X 3/8 TRS HD
41	M820309	.001	SEALANT, DOW CORNING
42	2177118	1	WASHER FLAT, ACETRON 1.250D X .94ID
43			
44	508135	.001	LUBE GREASE PETROL GEL 4 OZ
45	508033	.001	LUBRICANT FEL-PRO #51171
46	2172898	2	PANEL, SLOTTED
47			
48			
49	714039-03	3.5"	STRIP PROTECTIVE LINER
50			
51	324686	2	DECAL, DANGER STARTS AUTOMATIC
52	M820323	2.18'	TAPE INSUL 1 X 1/4 IN THICK
53	324014	1	DECAL BLK ARROW ON WHITE BACK

ITEM	STDELTING PN	QTY	DESCRIPTION
1	667892	1	SEAL, SHAFT, C118
2	3172965	1	ADAPTER, REAR SEAL
3	624857	1	RING O 21/4IDX25/BDDX3/16CS
4	3170878	1	BEARING HOUSING ASSY
5	766982	4	WASHER SHAKEPROOF 3/8 ZINC
6	644605	4	SCREW CAP 3/8-16 X 2 HX HD ZP
7	162156	2	BLADE SCRAPER HDPE
8	4172948	1	VELDMENT, AUGER
9	152227	1	BELT, POLY-V 34' LONG 6 GROOVE
10	744269	1	DRIP TRAY PER DVG 744269 C
11	1981462-0200	1	KEYSTOCK SQ CR 1/4 C 1/4 X 2.00
12	599170	1	BUSHING, PULLEY
13	598331	1	PULLEY, POLY-V 8.0' O.D. 6 GROOVE
14	454016	1	IDLER PER DVG 454016A
15	2171878	1	BRACKET, IDLER
16	223058	1	BUSHING SNAP 11/16ID 7/8 MTG
17	1172693	1	DRAIN TUBE
18	264061	1	CLAMP, LOOP TYPE JAW 5/8
19	644091	2	SCREW CAP 1/4-20 X 1/2 HX HD
20	375892	1	90 DEGREE ELBOW 1/2 X 1/2
21	538335	2	NUT HEX 1/4-20 X 7/16 STL ZP
22	644541	1	SCREW CAP 3/8-16 X 1 HX HD ZP
23	767216	1	WASHER FLAT 3/8X17/16 14GA ZP
24	766081	1	WASHER LOCK 3/8IN MED
25	324723	1	DECAL, TEMP ADJUSTMENT
26	756085	17.0'	TUBING, 1/2 ID X 5/8 OD CLEAR PVC

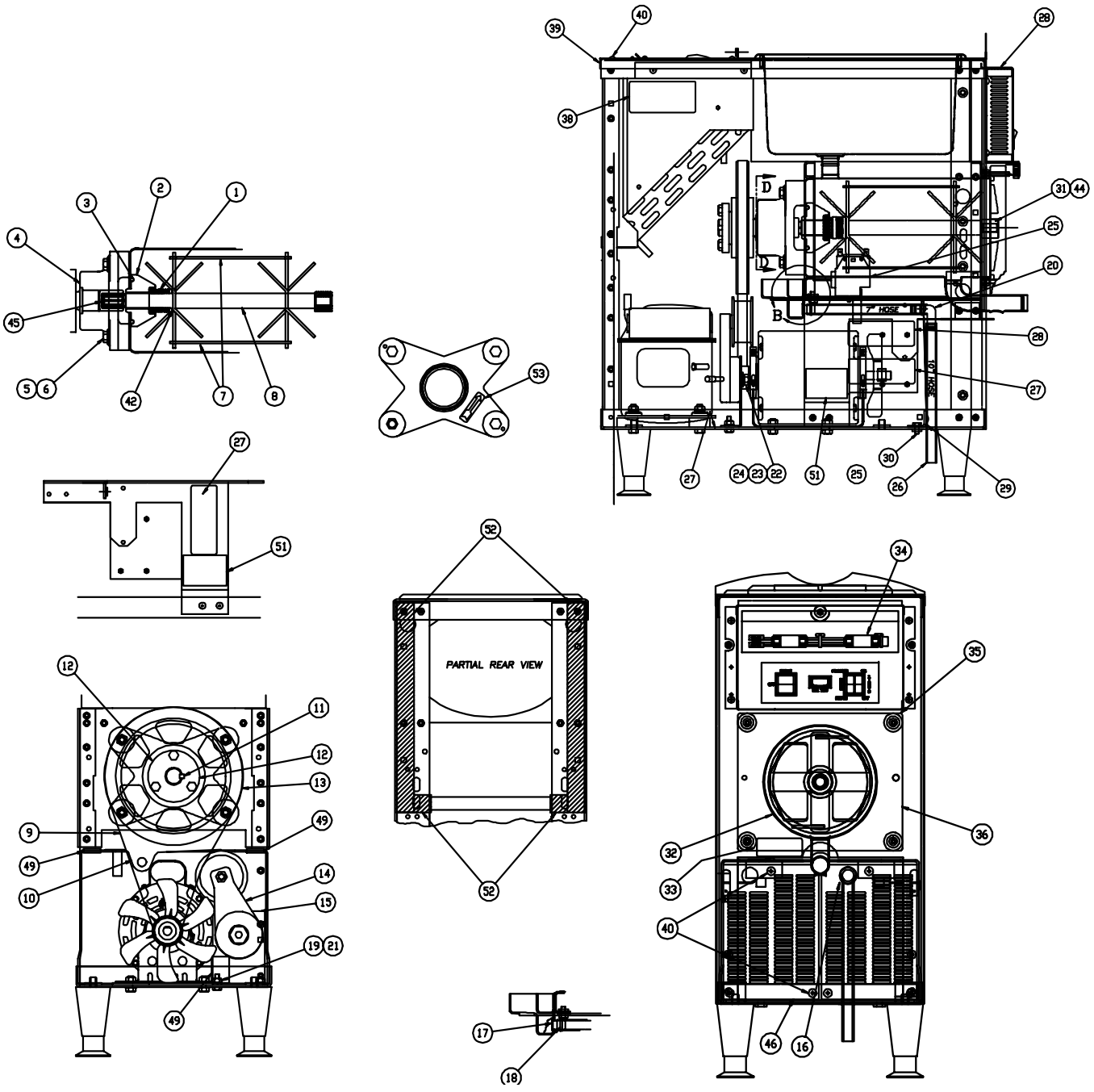

ITEM	STOELTING PN	QTY	DESCRIPTION
1	628007	4	RIVET 1/8DIA X .232LG STEEL
2	647483	2	SCREW, MACH 8-32 X 2 PAN HD
3	766941	2	WASHER SHAKEPROOF #8
4	538280	2	NUT HEX 8-32X11/32X1/8 STL
5	357036	1	FAN 6IN DIA
6	3172936	1	SHROUD, FAN
7	628032	6	RIVET, C'SUNK 3/16' DIA ALUM
8	284081	1	CONDENSER
9	282022	1	COMPRESSOR, 115V, 60Hz, 1PH
10	422065	4	GROMMET 7/16 HOLE DIA X .92 H
11	644355	4	SCREW CAP 5/16-18 X 1-1/2 HX
12	767211	4	WASHER FLAT 5/16,7/8X3/8X14GA
13	766073	4	WASHER LOCK 5/16 .125X.078 MED
14	684015	4	SLEEVE 5/16 ID X 29/32 LONG
15	644073	2	SCREW CAP 1/4-20 X 3/8 HX HD
16	647393	2	SCREW MACH 6-32 X 3/8 RD HD PH
17	766933	2	WASHER SHAKEPROOF 6X5/16
18	1172932	1	HI-PRESSURE CUT OUT BRACKET
19	718768	1	SWITCH HI-PRESS.LIMIT CONTROL
20	222997	1	BUSHING SNAP 9/32 ID, 3/8 HOLE
21	538344	4	NUT HEX 5/16-18 X 1/2 STL ZP

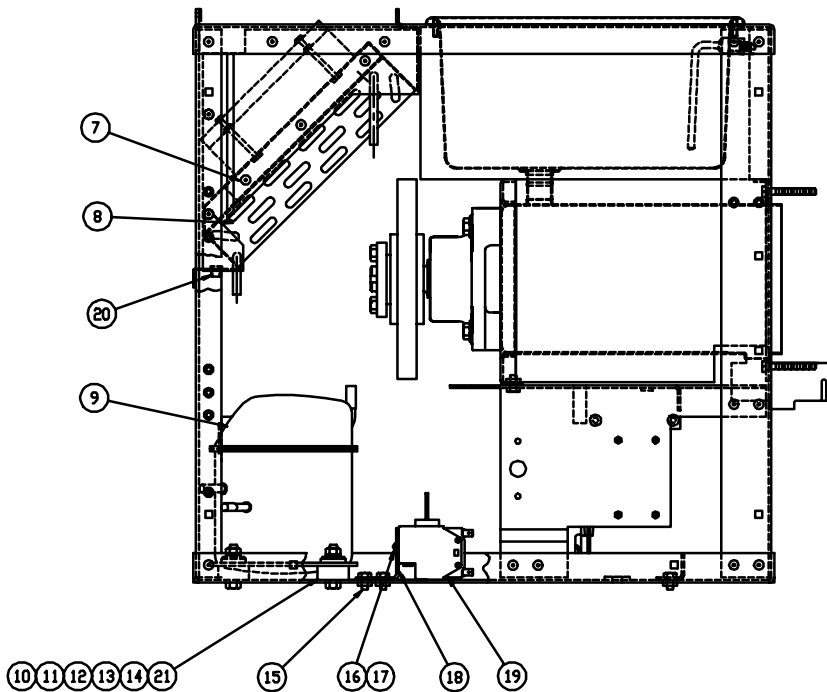
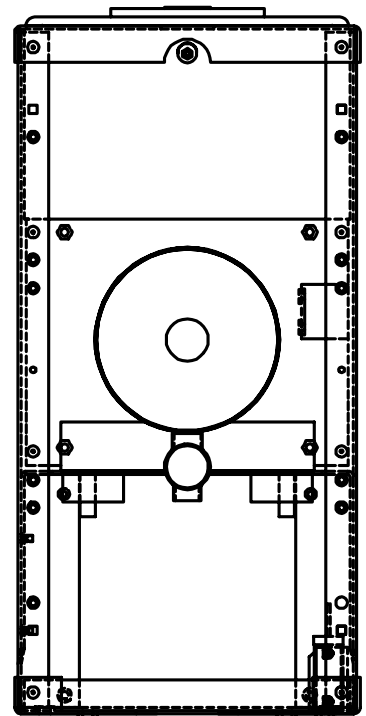
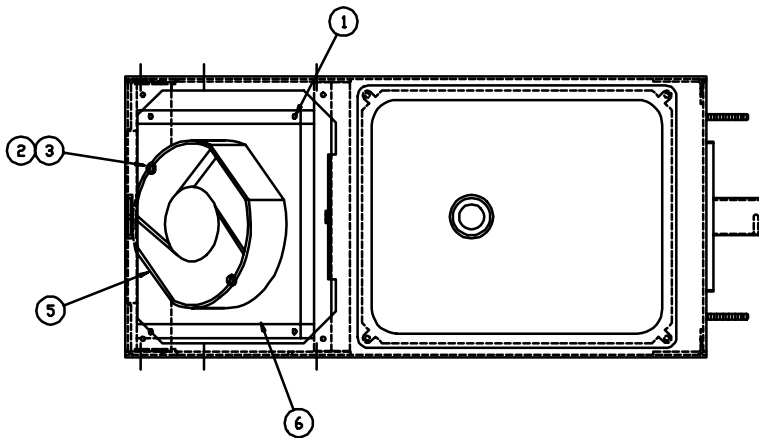

ITEM	STDELTING PN	QTY	DESCRIPTION
1	4172960-06	1	REFRIGERATION TUBING - SEE SHEET 3
2	4172960-01	1	REFRIGERATION TUBING - SEE SHEET 3
3	375127	2	FTG SOLDER RED EL 1/2X3/8 DD
4	342004	1	DRIER, FILTER
5	4172960-03	1	REFRIGERATION TUBING - SEE SHEET 3
6	519502	1	MASTIC THERMAL ND 440.22
7	739114	4	TIE 15IN LONG X 3/16WIDE WHITE
8	728091	1	TAPE INSULATING 1/8 X 2 X 30'
9	M820322	AS REQ	ADHESIVE ARMSTRONG R520
10	M860162	AS REQ	RUST INHIBITOR SPRAY 710
11	M000392	AS REQ	ALCOHOL, RUBBING
12	728220	4.6 FT	TAPE, ALUMINUM FOIL 2" WIDE
13	M002468	AS REQ	SILICONE
14	728221	5.0 FT	TAPE, VINYL FOAM
15	464262	23.0'	INSUL FOAM TUBING 3/8X1/4
16	756164	3.02'	TUBING REFRIG 1/4OD COPPER
17	756168	2.17'	TUBING REFRIG 3/8OD COPPER
18	615205	14 OZ	REFRIGERANT, R404A - DUPONT

NOTES

- 1: BRAZE AND APPLY RUST INHIBITOR (ITEM 10) PER SES 50-50-04.
- 2: WHEN BRAZING CONNECTIONS TO EXPANSION VALVE USE HEAT SINK TO PROTECT FROM OVER HEATING.
- 3: INSTALL DRIER LAST TO PREVENT CONTAMINATION OF DESSICANT.
- 4: INSULATE SUCTION LINES ONLY.
- 5: LEAK CHECK AND EVACUATE PER SES 50-54-17. CHARGE WITH 14OZ OF ITEM(18).

NOTE A: EXPANSION VALVE BULB MOUNTING.

NOTE: INSURE HANDS ARE CLEAN PRIOR TO STARTING STEP 1.

- STEP 1 CLEAN BULB AND SUCTION LINE WITH ITEM (11) ALCOHOL. LOCATE TXV BULB ON SUCTION LINE. ORIENT BULB ON TOP OF SUCTION LINE.
- STEP 2 CUT A 4" LONG PIECE OF ALUMINUM TAPE ITEM (12) CUT THIS PIECE IN HALF, RESULTING IN (2) 1" X 4" PIECES. SECURE BULB TO SUCTION LINE WITH FOIL TAPE.
- STEP 3 APPLY A SMALL AMOUNT OF SILICONE ITEM (13) OVER TXV CAPILLARY TUBE TO FORM A COMPLETE SEAL WHEN ALUMINUM TAPE IS APPLIED IN STEP 4.
- STEP 4 CUT (6) 4" LONG STRIPS OF ALUMINUM TAPE ITEM (12). WRAP FIRST 4" LONG PC. ONE TAPE WIDTH FROM END OF BULB (OPPOSITE CAPILLARY SIDE).
NOTE: ALL WRAPS ARE STRAIGHT NON-SPIRALLING. APPLY SECOND PC. WITH 1/2 OVERLAP. FORM OPEN END CLOSED. APPLY THIRD & FOURTH WRAPS WITH 1/2 OVERLAP. APPLY FIFTH WRAP WITH 1/2 OVERLAP PARTIALLY COVERING SILICONE. FORM OPEN END CLOSED. APPLY SIXTH WRAP OVER CAPILLARY TUBE. SEAL OVER SILICONE. SILICONE SHOULD OOOZE DUE TO SEALING. PRESS AND FORM ALUMINUM TAPE IN PLACE TO INSURE A GOOD SEAL.
- STEP 5 CLEAN ALUMINUM WRAP WITH ITEM (6) ALCOHOL.
NOTE: DO NOT CUT ITEM (14).
STARTING AT CAPILLARY END OF BULB, STRAIGHT WRAP (2) FULL TURNS OF ITEM (14) FOAM TAPE. SPIRAL WRAP WITH 1/2 OVERLAPS UNTIL FLUSH WITH END OF ALUMINUM TAPE. FINISH WITH (2) FULL STRAIGHT WRAPS.
- STEP 6 INSULATE SUCTION LINE FROM EVAPORATOR TO BULB AND FROM BULB TO NEXT COMPONENT.
FULL TAPES & PRESS SEAM TOGETHER FIRMLY. ADHERE INSULATION TO EVAPORATOR WITH ITEM (9) ADHESIVE.
- STEP 7 CUT INSULATION APPROX 1/2" LONGER THAN THE AREA TO BE COVERED OVER BULB. APPLY ADHESIVE ITEM (9) TO ALL ENDS TO BE CONTACTED. FIRMLY PRESS ALL SURFACES TO BE SEALED, CREATING AN AIR TIGHT SEAL. APPLY TIES ITEM (7) AFTER ADHESIVE HAS CURED.

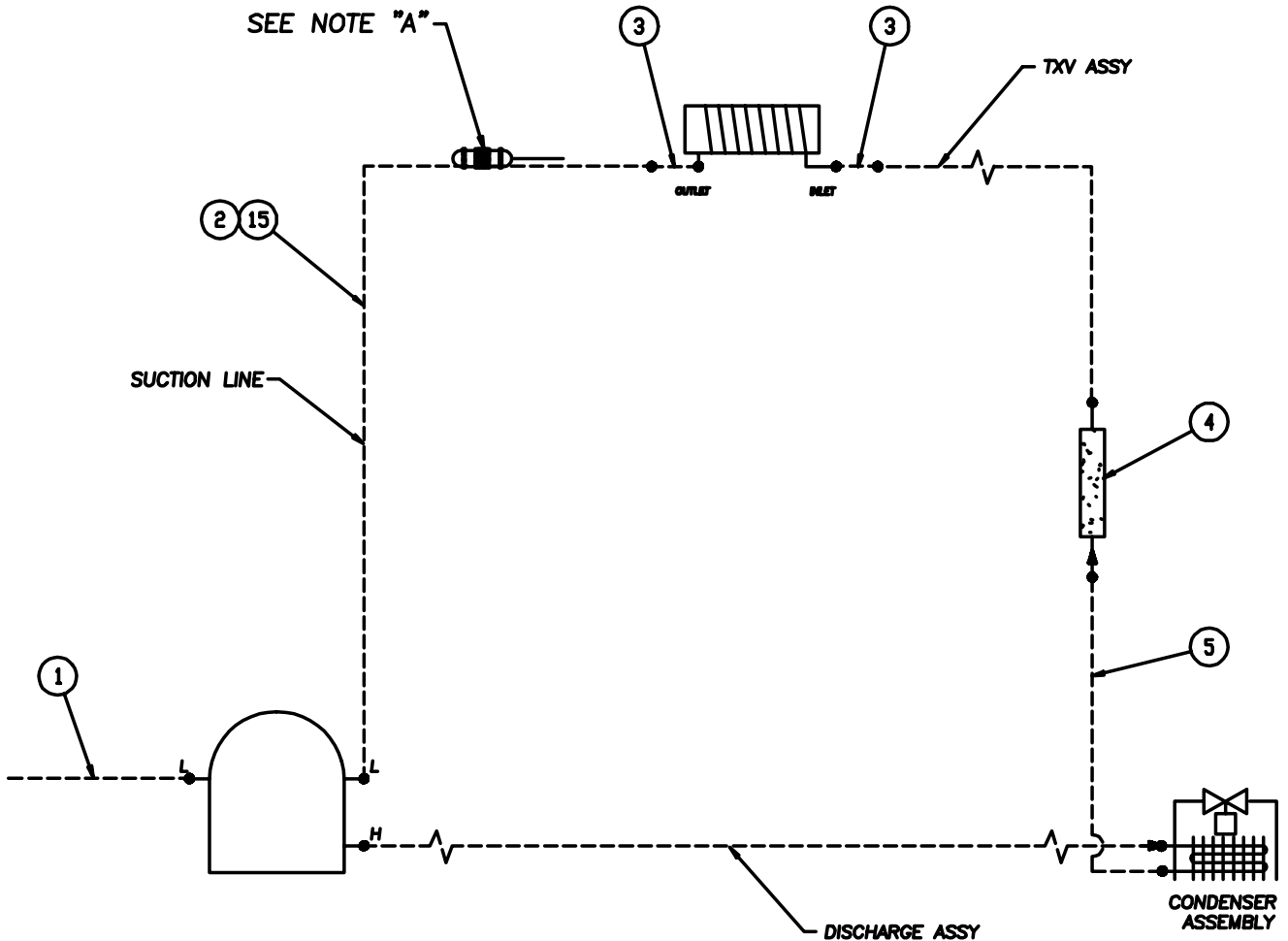

ITEM	STEELING PN	QTY	DESCRIPTION
1	4171837-12	1	REFRIGERATION TUBING, SEE SHEET 4
2	4171837-01	1	REFRIGERATION TUBING, SEE SHEET 4
3	342006	1	DRIER, FILTER
4	4171837-03	1	REFRIGERATION TUBING, SEE SHEET 4
5	762410	1	VALVE EXPANSION ADJUSTABLE
6	4171837-08	2	REFRIGERATION TUBING, SEE SHEET 4
7	4171837-09	2	REFRIGERATION TUBING, SEE SHEET 4
8	375242	4	FTG SOLDER TEE 1/4 OD
9	375003	1	FITTING, SHORT RAD.90 STR.ELBOW
10	375127	2	FTG SOLDER RED EL 1/2X3/8 OD
11	342020	1	DRIER
12	4171837-10	1	REFRIGERATION TUBING, SEE SHEET 4
13	4171837-11	2	REFRIGERATION TUBING, SEE SHEET 4
14	4171837-05	1	REFRIGERATION TUBING, SEE SHEET 4
15	4171837-02	1	REFRIGERATION TUBING, SEE SHEET 4
16	4171837-07	1	REFRIGERATION TUBING, SEE SHEET 4
17	4171837-06	1	REFRIGERATION TUBING, SEE SHEET 4
18	375253	1	FTG SOLDER TEE 3/8 X3/8 X1/4OD
19	4171837-04	1	REFRIGERATION TUBING, SEE SHEET 4
20	375011	1	FTG SOLDER ELBOW 90DEG 3/8 OD
21	375813	2	ACCESS FITTING ASSEMBLY
22	762978	1	VALVE EPR R22
23	231105	1	CAPILLARY TUBE .072 X .026
24	374845	1	FITTING, REDUCER
25	762359	2	VALVE CORE
26	232065	1	CAP, QUICK SEAL, 1/4" SAE

NOTES:

1. FOR BRAZING, SEE SES-50-50-4
2. PROTECT SUB-ASSEMBLIES IF PUT INTO STOCK.
3. CAP TUBE TO FEED FRONT HOPPER TUBE. LOCATE CAP TUBE TO SIDE OF EVAPORATOR & MOUNT TO TOP OF EVAPORATOR SUPPORT

EPR VALVE ASSY

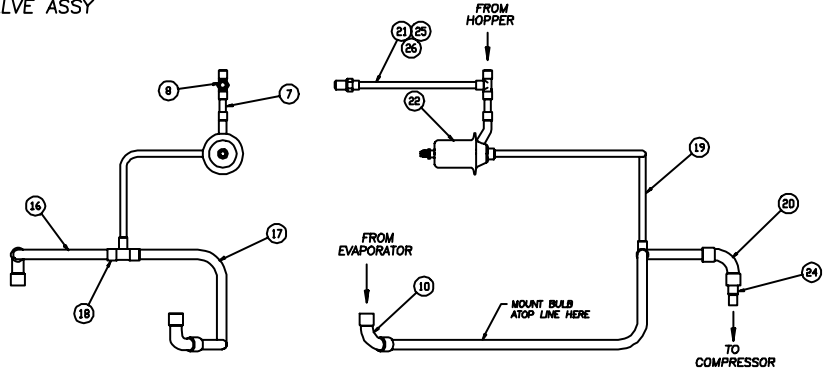

TXV ASSY

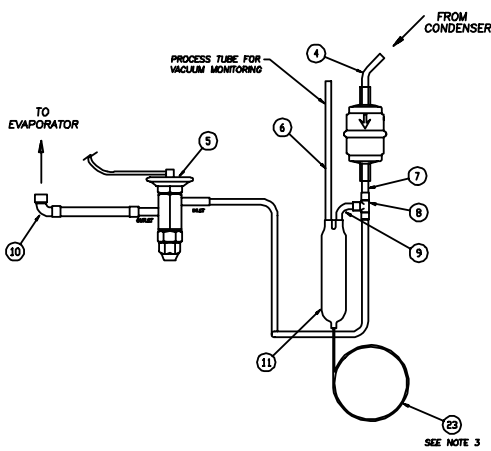
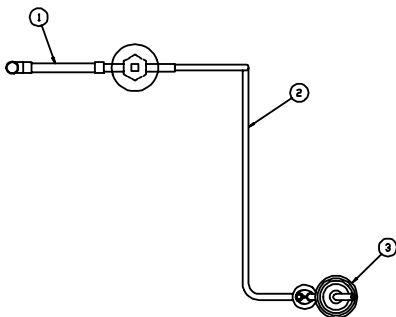

DISCHARGE ASSY

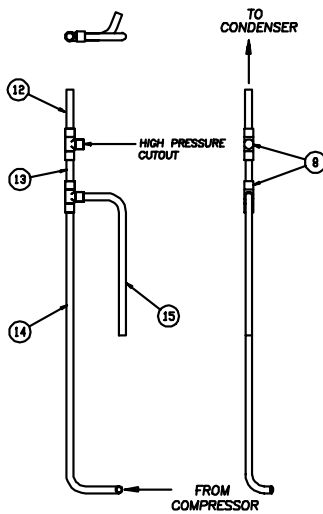

PROCESS LINE ASSY

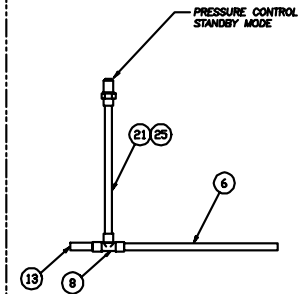

30	223058	2	BUSHING SNAP 11/16ID 7/8 MTG
31	598280	4	NUT HEX 8-32X11/32X1/8 STL
32	796209	.50"	TUBING VACUUM 7/32ID X 13/32OD
33	1171921	1	BRACKET, TORQUE SWITCH
34	1171924	1	BRACKET, ADJUSTING
35	1171923	1	BRACKET, ADJUSTING SCREW
36	430168	1	HARNESS POWER CORD 15 AMP 125V
37	223162	1	BUSHING STRAIN RELIEF 7/8 HOLE
38	714035	.62"	STRIP, EDGE LINER PROTECTOR
39	3177154	1	BRACKET, ELECTRICAL
40	524091	5	MOUNT ADHESIVE BACK 1X1 PLASTC
41	739040	5	TIE 8.0 LG X 1/8 WIDE NEUTRAL
42	647665	1	SCREW MACH 10-32 X 3/8 HX HD
43	146449	2	BEARING, BALL 15748 ID
44	701005	4	STANDOFF, SCREW GRDNMET #10
45	1172969	2	BUSHING, MOTOR
46	766940	8	WASHER SHAKEPROOF 8 ZINC PLATE
47	647513	5	SCREW MACH 8-32 X 3/8 RD HD PH
48	538351	4	NUT HEX 5/16-18 X 1/2 STL ZP LF
49	1170836	1	LIMIT SWITCH (DOOR SAFETY)
50	162051	1	BLADE, FAN 6" CW
51	162052	1	BLADE, FAN 6" CCW
52	598012	1	PULLEY, POLY-V 1.50" O.D. 6 GROOVE
53	M820172	.001	ADHESIVE LOCTITE 242-31
54	538265	2	NUT HEX #6-32 X 5/16 STL ZP
55	647650	1	SCREW MACH 10-24 X 1/2 FL HD
56	647499	2	SCREW MACHINE 8-32 X 1/4
57	295011	1	CONTACTOR MAGNETIC 2 POLE
58	2177028	2	CLIP, SPRING
59	538327	4	NUT, HEX JAM 1/4-20 S'STL
60	771004	1	WINDOW, FRONT
61	771005	1	WINDOW, LOWER
62	M820309	.001	SEALANT DOW CORNING ALUMINUM

ITEM	STDELTING PN	QTY	DESCRIPTION
1	766948	6	WASHER SHAKEPROOF 10 ZINC
2	647658	9	SCREW MACH 10-24 X 3/8 RD HD
3	74414E	2	TRANSFORMER
4	647393	4	SCREW MACH 6-32 X 3/8 RD HD PH
5	766933	8	WASHER SHAKEPROOF 6X5/16
6	647645	4	SCREW MACH 10-24 X 1/4 TRS HD
7	732010	1	TERMINAL BLOCK
8	.	.	.
9	296179	1	CONTROL LIQUID LEVEL 24V
10	739543	1	TIMER, DELAY-ON-MAKE
11	718886	1	SWITCH, ROCKER 15 AMP 125 VAC
12	M970188	.001	LOCTITE 454
13	458104	1	INDICATOR, LIGHT 28V RED LENS
14	718887	1	SWITCH, ROCKER 15 AMP 125 VAC
15	324676	1	DECAL, SWITCH BDX
16	1170836-01	1	LIMIT SWITCH ASSEMBLY
17	2177151	1	DOOR SWITCH BRACKET
18	647441	2	SCREW MACH 6-32 X 1 RD HD PH
19	3177185	1	FRONT PANEL & LIGHT ASSY
20	522418	1	MOTOR, 1/3HP 115V 60HZ 1 PHASE
21	644307	4	SCREW CAP 5/16-18 X 3/4 HX HD
22	647432	2	SCREW MACH 6-32 X 7/8 PAN HD
23	766568	4	WASHER, FLAT RUBBER 2-1/4 OD X 3/8
24	482004	1	KNOB PLASTIC BLACK 3/4" DIA
25	647979	1	SCREW, 1/4-20 X 2-1/2 SS SLOTTED
26	695763	1	SPRING, EXT .240 OD X 3 FREE LENGTH
27	2172951	1	BRACKET, MOTOR
28	3177113	1	BDX, SWITCHES & LIGHTS
29	647653	2	SCREW MACH 10-24 X 3/8 TRS HD

SECTION D-D

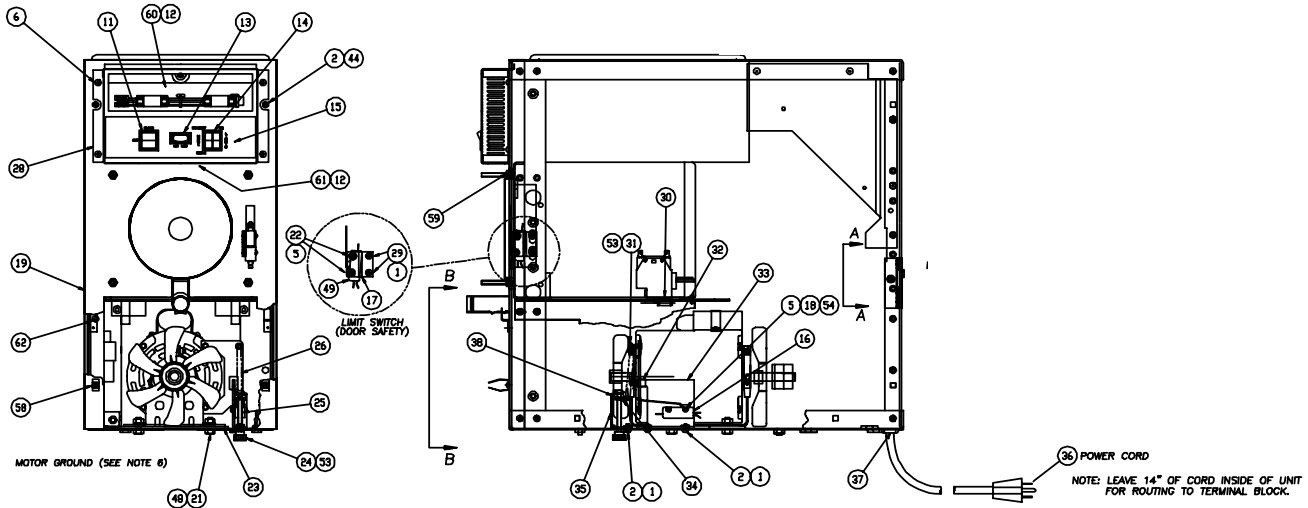

MOTOR GROUND (SEE NOTE 6)

NOTE: LEAVE 14" OF CORD INSIDE OF UNIT FOR ROUTING TO TERMINAL BLOCK.

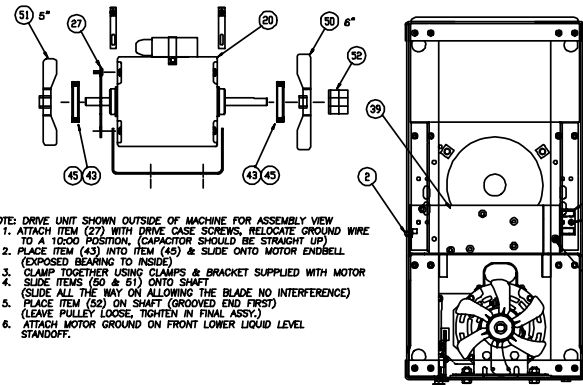

REAR

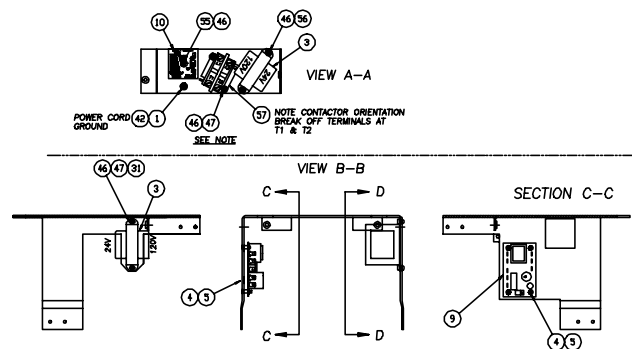

ITEM	STOELTING PN	QTY	DESCRIPTION
1	430776	1	HARNESS, 4 WIRE
2	430777	1	HARNESS, 7 WIRE
3	430778	1	HARNESS, 6 WIRE
4	430779	1	HARNESS, 3 WIRE
5	430780	1	HARNESS, 4 WIRE
6			
7	430782	1	HARNESS, 5 WIRE
8	430783	1	HARNESS, 2 WIRE
9	732096	2	TERMINAL FEMALE 14-16 GA
10	732133	4	TERMINAL
11	732116	13	TERMINAL FEMALE 18-20 GA
12	739040	2	TIE 8.0' LG X 1/8 VD
13	732202	1	1/4' TERMINAL FULLY INSULATED QC

14	538296	1	NUT HEX #10 X 3/8 SS
15	766950	1	SHAKEPROOF WASHER #10
16	430784	1	HARNESS, WIRE VKK02E2B
17	430631	1	VAA05E2B HARNESS

NOTES:

1. LIGHT TRANSFORMER DO NOT TRIM LEADS. TERMINATE BLACK, WHITE, BLUE & YELLOW WIRES WITH ITEM(11) FEMALE TERMINALS.
2. POWER TRANSFORMER: TRIM WHITE & YELLOW LEADS TO 4" LONG; BLACK & BLUE LEADS SHOULD BE FULL LENGTH. TERMINATE BLACK, WHITE, YELLOW & BLUE LEADS WITH ITEM(11) FEMALE TERMINALS.
3. CAP OFF RED & ORANGE WIRES ON EACH TRANSFORMER WITH ITEM(10) TERMINALS. COIL CRIMPED WIRES & SECURE WITH ITEM(12).
4. TRIM WHITE LEAD OF DRIVE MOTOR TO 4" AND TERMINATE WITH ITEM(11) FEMALE TERMINAL. TERMINATE BLACK MOTOR LEAD WITH ITEM(11) FEMALE TERMINAL ALONG WITH BOTH MOTOR THERMOSTAT LEADS (ORANGE). MOTOR TO BE WIRED FOR CLOCKWISE ROTATION FACING LEAD END. (PURPLE TO YELLOW) (PURPLE TO YELLOW)
5. TERMINATE POWER CORD LEADS WITH ITEM(9) FEMALE TERMINALS.
6. MOUNT LIGHT TRANSFORMER W/LOW VOLTAGE TO TOP. MOUNT POWER TRANSFORMER W/LOW VOLTAGE TO REAR OF FREEZER.
7. TRIM FAN MOTOR WIRES TO 25" LONG.(ORANGE, YELLOW & BLACK). TRIM BLUE & WHITE WIRES TO 6". TERMINATE THESE WIRES WITH ITEM (10), COIL THEM & TIE TO CONDENSER BRACKET. ROUTE THE ORANGE, YELLOW & BLACK WIRES THROUGH HOLE IN SHROUD. TERMINATE THE BLACK WIRE WITH ITEM (11). THE YELLOW & ORANGE GET TERMINATED TOGETHER WITH ITEM (13). ROUTE FAN WIRES AWAY FROM BLADE & SECURE WITH ITEM (12).
8. ATTACH ITEM (15), THEN RING TERMINAL FOR LIQUID LEVEL PROBE. TIGHTEN DOWN WITH ITEM (14) & RTV TO COMPLETE LIQUID LEVEL PROBE

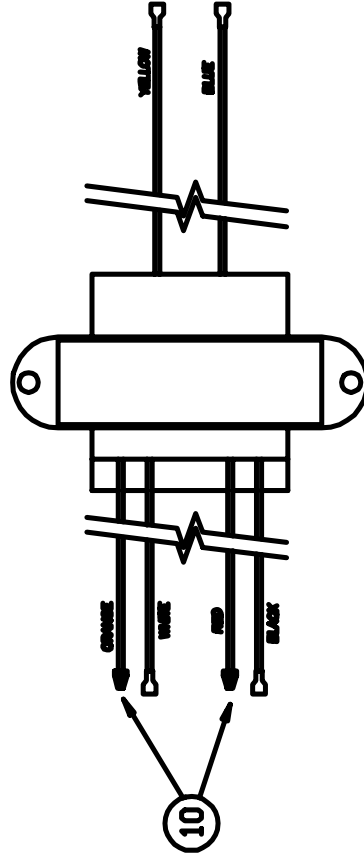

LIGHT TRANSFORMER

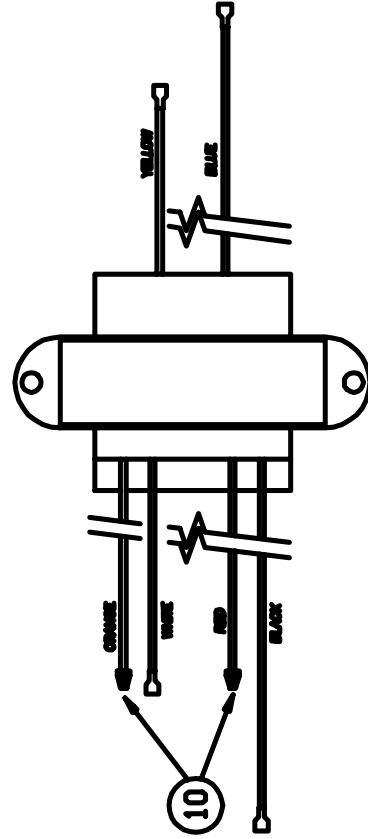

POWER TRANSFORMER

