



Model O212B
OPERATORS MANUAL

Manual No. [513705](#)

Rev.1

This manual provides basic information about the machine. Instructions and suggestions are given covering its operation and care.

The illustrations and specifications are not binding in detail. We reserve the right to make changes to the machine without notice, and without incurring any obligation to modify or provide new parts for machines built prior to date of change.

DO NOT ATTEMPT to operate the machine until instructions and safety precautions in this manual are read completely and are thoroughly understood. If problems develop or questions arise in connection with installation, operation, or servicing of the machine, contact Stoelting.



stoeltingfoodservice.com

Stoelting Foodservice Equipment
502 Highway 67
Kiel, WI 53042-1600
U.S.A.

White Glove Service Network
Phone: 888.319.9549

© 2017 Stoelting

A Few Words About Safety

Safety Information

Read and understand the entire manual before operating or maintaining Stoelting equipment.

This manual provides the operator with information for the safe operation and maintenance of Stoelting equipment. As with any machine, there are hazards associated with their operation. For this reason safety is emphasized throughout the manual. To highlight specific safety information, the following safety definitions are provided to assist the reader.

The purpose of safety symbols is to attract your attention to possible dangers. The safety symbols, and their explanations, deserve your careful attention and understanding. The safety warnings do not by themselves eliminate any danger. The instructions or warnings they give are not substitutes for proper accident prevention measures.

If you need to replace a part, use genuine Stoelting parts with the correct part number or an equivalent part. We strongly recommend that you do not use replacement parts of inferior quality.



Safety Alert Symbol:

This symbol Indicates danger, warning or caution. Attention is required in order to avoid serious personal injury. The message that follows the symbol contains important information about safety.

Signal Word:

Signal words are distinctive words used throughout this manual that alert the reader to the existence and relative degree of a hazard.



The signal word “WARNING” indicates a potentially hazardous situation, which, if not avoided, may result in death or serious injury and equipment/property damage.



The signal word “CAUTION” indicates a potentially hazardous situation, which, if not avoided, may result in minor or moderate injury and equipment/property damage.

CAUTION

The signal word “CAUTION” not preceded by the safety alert symbol indicates a potentially hazardous situation, which, if not avoided, may result in equipment/property damage.

NOTE (or NOTICE)

The signal word “NOTICE” indicates information or procedures that relate directly or indirectly to the safety of personnel or equipment/property.

TABLE OF CONTENTS

Section	Description	Page
1	Description and Specifications	
1.1	Description.....	1
1.2	Specifications	2
2	Installation Instructions	
2.1	Safety Precautions	3
2.2	Shipment and Transit.....	3
2.3	Machine Installation.....	3
3	Initial Set-Up and Operation	
3.1	Operator's Safety Precautions	5
3.2	Operating Controls and Indicators	5
3.3	Assembly of Machine	6
3.4	Sanitizing	7
3.5	Freeze Down and Operation	8
3.6	Mix Information	8
3.7	Removing Mix From Machine.....	8
3.8	Cleaning the Machine.....	8
3.9	Disassembly of Machine Parts	8
3.10	Cleaning and Sanitizing The Machine Parts.....	9
3.11	Sanitize Machine	9
3.12	Routine Cleaning	9
3.13	Preventive Maintenance	10
3.14	Extended Storage.....	10
4	Troubleshooting	
4.1	Light Indicators	11
4.2	Troubleshooting.....	11
5	Replacement Parts	
5.1	Brushes, Decals, and Lubrication.....	13
5.2	Auger Shaft and Faceplate Parts	14
5.3	Hopper Parts	15

SECTION 1 DESCRIPTION AND SPECIFICATIONS

1.1 DESCRIPTION

The Stoelting O212B floor model machine is gravity fed. The machine is equipped with fully automatic controls to provide a uniform product. The machine will operate with almost any type of shake mix. This manual is designed to help qualified service personnel and operators with the installation, operation and maintenance of the Stoelting O212B gravity machine.



Figure 1-1 Model O212B

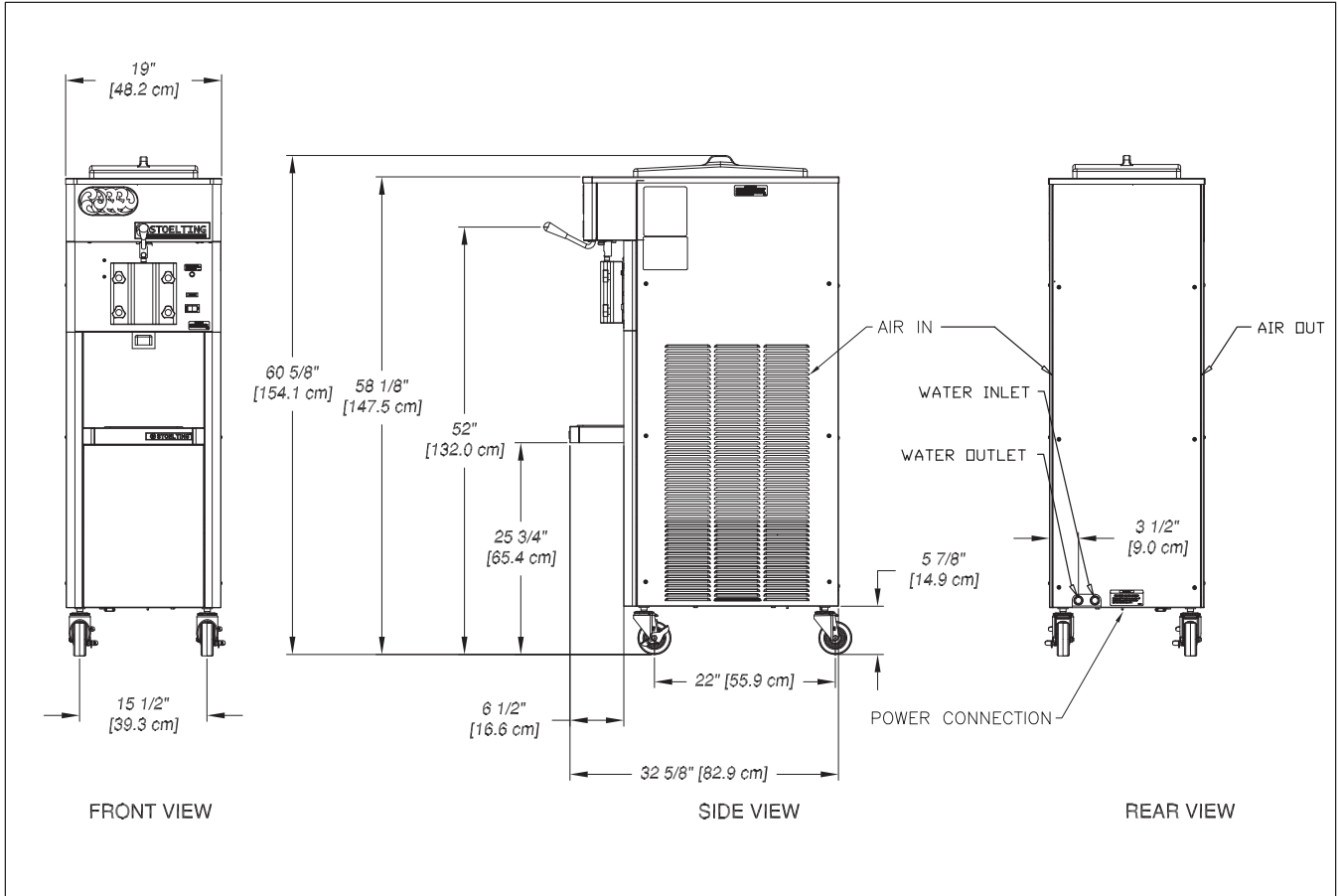

1.2 SPECIFICATIONS

Model O212B		
Dimensions	Machine	with crate
width	19" (48,3 cm)	25" (63,5 cm)
height	60-5/8" (154,0 cm)	66" (167,6 cm)
depth	32-5/8" (82,9 cm)	51" (129,5 cm)
Weight	315 lbs (142,8 kg)	500 lbs (226,7 kg)
Electrical	1 Phase, 208-240 VAC, 60Hz	
running amps	11A	
connection type	NEMA6-20P power cord provided	
Compressor	12,000 Btu/hr	
Drive Motor	3/4 hp	
Air Flow	Air cooled units require 3" (7,6 cm) air space on both sides	
Plumbing Fittings	Water cooled units require 3/8" N.P.T. water and drain fittings	
Hopper Volume	6.5 gallon (24,61 liters)	
Freezing Cylinder Volume	2 gallon (7,57 liters)	

SECTION 2 INSTALLATION INSTRUCTIONS

2.1 SAFETY PRECAUTIONS

Do not attempt to operate the machine until the safety precautions and operating instructions in this manual are read completely and are thoroughly understood.

Take notice of all warning labels on the machine. The labels have been put there to help maintain a safe working environment. The labels have been designed to withstand washing and cleaning. All labels must remain legible for the life of the machine. Labels should be checked periodically to be sure they can be recognized as warning labels.

If danger, warning or caution labels are needed, indicate the part number, type of label, location of label, and quantity required along with your address and mail to:

STOELTING
ATTENTION: Customer Service
502 Hwy. 67
Kiel, Wisconsin 53042

2.2 SHIPMENT AND TRANSIT

The machine has been assembled, operated and inspected at the factory. Upon arrival at the final destination, the entire machine must be checked for any damage which may have occurred during transit.

With the method of packaging used, the machine should arrive in excellent condition. **THE CARRIER IS RESPONSIBLE FOR ALL DAMAGE IN TRANSIT, WHETHER VISIBLE OR CONCEALED.** Do not pay the freight bill until the machine has been checked for damage. Have the carrier note any visible damage on the freight bill. If concealed damage and/or shortage is found later, advise the carrier within 10 days and request inspection. The customer must place claim for damages and/or shortages in shipment with the carrier. Stoelting, Inc. cannot make any claims against the carrier.

2.3 MACHINE INSTALLATION



WARNING

Installation must be completed by a qualified electrician/refrigeration specialist.

Incorrect installation may cause personal injury, severe damage to the machine and will void factory warranty.

Installation of the machine involves moving the machine close to its permanent location, removing all crating, setting in place, assembling parts, and cleaning.

- A. Uncrate the machine.
- B. Accurate leveling is necessary for correct drainage of machine barrel and to insure correct overrun. Place a bubble level on top of the machine at each corner to check for level condition. If adjustment is necessary, level the machine by turning the caster leveling nut in or out then tightening the locking nut.
- C. Correct ventilation is required. The O212B requires 3" clearance on both sides for proper air flow.

CAUTION

Failure to provide adequate ventilation will void warranty.

- D. Open the rear panel and check the belt tension with a Burroughs Belt Tension Gauge. The tension should be 45-55 lbs. Adjust as necessary and check the pulley alignment with a straightedge.

NOTE

Belt life will be increased if the new drive belts are tightened after two or three weeks of operation.

- E. Place the CLEAN-ON-OFF switch in the OFF position.
- F. Connect the power cord to the proper power supply. Refer to the nameplate on your machine for proper supply. The unit must be connected to a properly grounded receptacle. The use of an extension cord is not recommended. Do not use an adapter to circumvent the grounding requirement.



WARNING

Do not alter or deform electrical plug in any way. Altering the plug to fit into an outlet of different configuration may cause fire, risk of electrical shock, product damage and will void warranty.

- G. The machine is ready for use. Follow the instructions in Section 3 for disassembling, cleaning and sanitizing.

SECTION 3 OPERATION

3.1 OPERATOR'S SAFETY PRECAUTIONS

SAFE OPERATION IS NO ACCIDENT; observe these rules:

- A. Know the machine. Read and understand the Operating Instructions.
- B. Notice all warning labels on the machine.
- C. Wear proper clothing. Avoid loose fitting garments, and remove watches, rings or jewelry that could cause a serious accident.
- D. Maintain a clean work area. Avoid accidents by cleaning up the area and keeping it clean.
- E. Stay alert at all times. Know which switch, push button or control you are about to use and what effect it is going to have.
- F. Disconnect electrical cord for maintenance. Never attempt to repair or perform maintenance on the machine until the main electrical power has been disconnected.
- G. Do not operate under unsafe operating conditions. Never operate the machine if unusual or excessive noise or vibration occurs.

3.2 OPERATING CONTROLS AND INDICATORS

Before operating the machine, it is required that the operator know the function of each operating control. Refer to Figure 3-1 for the location of the operating controls on the machine.



WARNING

High voltage will shock, burn or cause death. The OFF-ON switch must be placed in the OFF position prior to disassembling for cleaning or servicing. Do not operate machine with cabinet panels removed.

A. CLEAN-OFF-ON Switch

The CLEAN-OFF-ON switch is used to supply power to the control circuit. When the switch is in the OFF (middle) position, power is not supplied to the control board or refrigeration system. When the switch is in the ON position, the machine operates in the freezing mode. (If installed, the hopper agitator operates with hopper refrigeration) When the switch is in the CLEAN position, all refrigeration stops and the auger rotates.

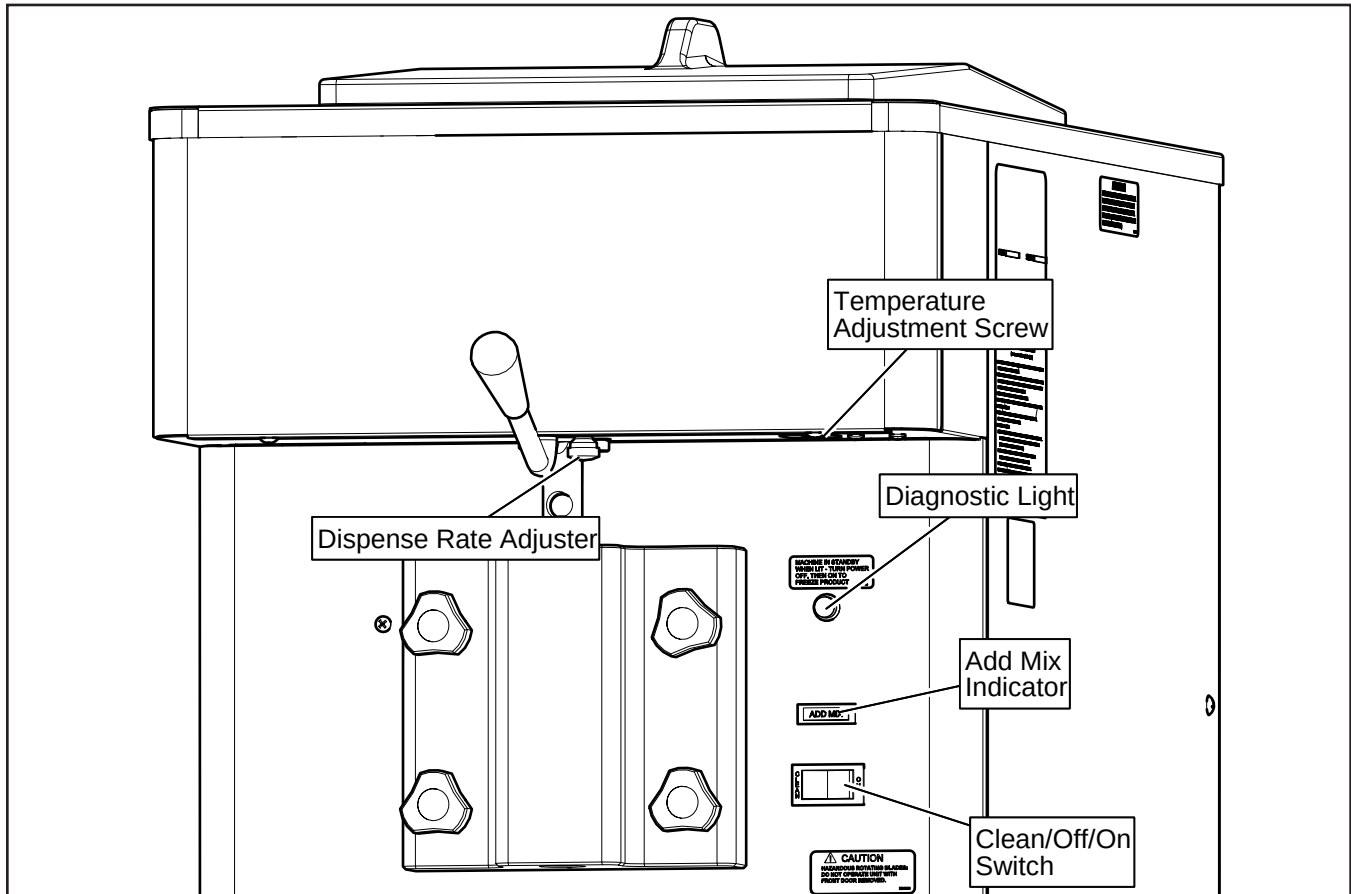

Figure 3-1 Controls

C. ADD MIX Indicator

The ADD MIX light flashes to alert the operator to a low mix condition. It does so by monitoring the mix level in the hopper. When the ADD MIX light is flashing, refill hopper immediately.

NOTE

Failure to refill the hopper immediately may result in operational problems.

D. Diagnostic Light

The Diagnostic Light remains on during standby mode. It flashes if an error occurs. The light flashes once if there is a compressor error. There are two quick flashes if there is a drive motor error. And there are three quick flashes if the machine is left in clean mode for more than 20 minutes. Refer to the troubleshooting section for details.

E. Temperature Adjustment Screw

The Temperature Adjustment Screw is located under the header panel. It is used to adjust product temperature. Making product colder also increases product consistency (thicker product) and vice versa.

When setting the temperature, adjust the screw 1/8 of a turn and retest before making another adjustment (use the markings on the decal on the underside of the header panel). Turn it to the right to make product colder or to the left to make product warmer.

F. Front Door Safety Switch

The front door safety switch prevents the auger from turning when the front door is removed. The switch is open when the door is not in place and closed when the door is properly installed.

G. Dispense Rate Adjuster

The dispense rate adjuster limits the opening of the spigot and is located under the header panel, to the immediate right of the spigot handle. Turning the knob counterclockwise decreases the dispense rate.

3.3 EMPTYING THE FREEZING CYLINDER

If the machine is empty, go to Section 3.4

- A. Pull the mix inlet regulator straight up and remove it from the hopper.
- B. Place the switch in the CLEAN position to rotate the auger.
- C. Drain the mix by opening the spigot. A container should be placed under the spigot to collect the mix.
- D. Place the switch in the OFF (middle) position.

- E. Fill the hopper with 2 gallons of cool tap water. Optional: Use detergent solution instead of tap water to make cleaning the parts easier after disassembly.
- F. Place the switch in the CLEAN position and let the auger rotate for at least 30 seconds.
- G. While the auger is rotating, scrub the hopper with a clean brush.
- H. Drain the water out of the machine and place the switch in the OFF position.

NOTE

If the water does not drain clear, repeat steps E through H.

3.4 DISASSEMBLY OF MACHINE PARTS

Before using the machine for the first time, complete machine disassembly, cleaning, and sanitizing procedures need to be followed. Routine cleaning intervals and procedures must comply with the local and state health codes. Inspection for worn or broken parts should be made at every disassembly of the machine. All worn or broken parts should be replaced to ensure safety to both the operator and the customer and to maintain good machine performance and a quality product. Check the wear line on the auger flights on a regular basis (Fig. 3-2) and replace as needed. Frequency of cleaning must comply with the local health regulations.

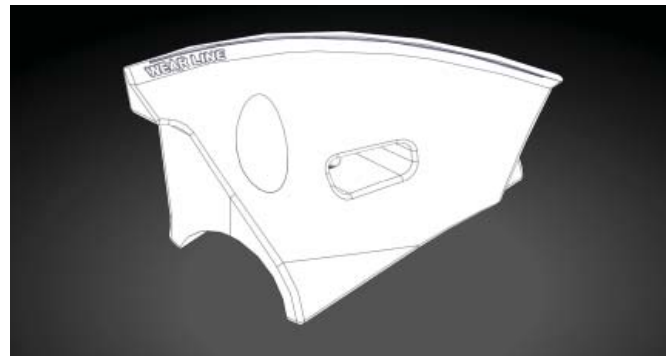

Figure 3-2 Auger Flight Wear

To disassemble the machine, refer to the following steps:

A. DISASSEMBLY OF FRONT DOOR

- 1. Make sure the Clean/Off/On switch is in the OFF position.
- 2. Remove the front door by unscrewing the knobs and then pulling the door off the studs.
- 3. Remove the spigot through the bottom of the front door.

4. Remove all o-rings from parts by first wiping off the lubricant using a clean towel. Then squeeze the o-ring upward to form a loop. Roll the o-ring out of the groove.

CAUTION
Do not use any type of sharp object to remove the o-rings.

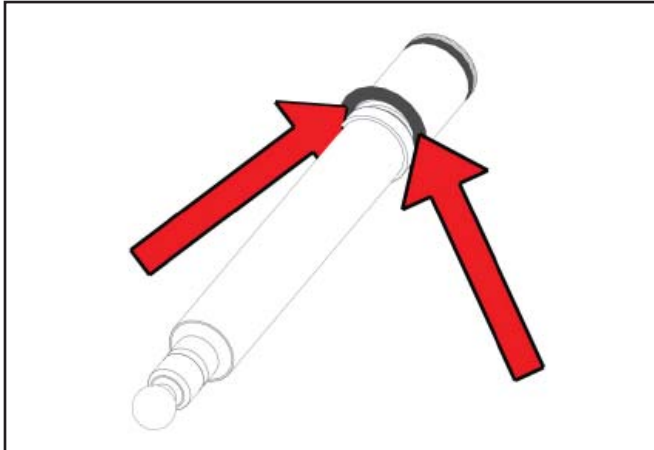

Figure 3-3 Removing O-Ring

B. DISASSEMBLY OF AUGER

1. Remove the front auger bushing.
2. Remove the auger assembly from the machine. Pull the auger out of the freezing cylinder slowly. As the auger is being pulled out, carefully remove each of the plastic flights with springs.
3. Keep the rear of the auger tipped up once it is clear of the freezing cylinder to prevent the rear seal assembly from dropping.
4. Wipe the lubricant off of the hex end of the auger shaft with a paper towel. Remove the rear seal assembly.
5. Wipe any excess lubricant off the rear seal.
6. Unscrew the springs from the auger flights.

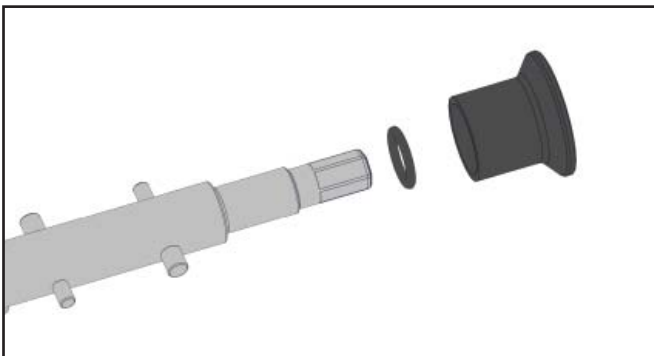

Figure 3-4 Rear Seal Assembly

3.5 CLEANING AND SANITIZING THE MACHINE PARTS

Disassembled parts require complete cleaning, sanitizing and air drying before assembling. Local and state health codes dictate the procedure required. Some state health codes require a four sink process (pre-wash, wash, rinse, sanitize, air dry), while others require a three sink process (without the pre-wash step). The following procedures are a general guideline only. Consult your local and state health codes for the procedures required in your location.

- A. Disassemble all parts. (Refer to Section 3.4 for the disassembly of machine parts)
- B. Place all parts in 90° to 110°F (32°C to 43°C) mild detergent water and wash thoroughly. Use the brushes that shipped with the machine to clean all holes in the front door, flights, mix pickup assembly, etc.
- C. Rinse all parts with clean 90° to 110°F (32°C to 43°C) water.
- D. Place all parts in a sanitizing solution for at least 1 minute, then remove and let air dry completely before assembling in machine.

3.6 CLEANING THE MACHINE

INTERIOR

- A. Using detergent solution and the large barrel brush provided, clean the hopper and freezing cylinder.

NOTE

Make sure to thoroughly clean the rear seal surface on the inside of the freezing cylinder.

- B. Wrap the brush in a clean cloth and thoroughly dry the hopper and freezing cylinder.
- C. Remove the drip tray and drain tray. Clean and replace the trays.

EXTERIOR

The exterior should be kept clean at all times to preserve the luster of the stainless steel. A high grade of stainless steel has been used on the machine to ease cleanup. To remove spilled or dried mix, wash the exterior with 90° to 110°F (32°C to 43°C) mild detergent water and wipe dry.

Do not use highly abrasive materials, as they will mar the finish. Use a soft cloth or sponge to apply the solution. For best results, wipe with the grain of the steel.

3.7 ASSEMBLING MACHINE

To assemble the machine parts, refer to the following steps:

NOTICE

Total Blend sanitary lubricant or equivalent must be used when lubrication of parts is specified.

Total Blend can be used in place of two products. It is used to lubricate parts and also used in place of spline lubricant. Do not use more than one packet of Total Blend per freezing cylinder.

NOTICE

The United States Department of Agriculture and the Food and Drug Administration require that lubricants used on food processing equipment be certified for this use. Use lubricants only in accordance with the manufacturer's instructions.

- A. Install the rear seal o-ring onto the auger. Lubricate the outside of the o-ring with a generous amount sanitary lubricant.
- B. Lubricate the inside metal surface of the rear seal (Fig. 3-6) and install it onto the auger shaft. DO NOT lubricate the outside of the rear auger seal.



Figure 3-5 Lubricate Rear Seal

- C. Lubricate the hex end of the auger with a small amount of Total Blend lubricant.
- D. Screw the springs onto the studs in the plastic flights. The springs must be screwed into the flights completely to provide proper compression.
- E. Install the two plastic flights onto the rear of the auger and insert it part way into the freezing cylinder.



Figure 3-6 Lubricate Hex End of Auger

- F. Install the remaining plastic flights, push the auger into the freezing cylinder and rotate slowly until the auger engages the drive shaft.
- G. Apply a thin layer of sanitary lubricant to the inside and outside of the auger support bushing. Install the bushing onto the auger support and install the auger support into the front of the auger. Rotate the auger support so that one leg of the support points straight up.
- H. Install the o-rings onto the spigot body and apply a thin layer of sanitary lubricant to the o-rings. Install the spigot body through the bottom of the front door.
- I. Fit the front door o-ring into the groove on the rear of the front door.
- J. Place the front door assembly on the mounting studs and the push front door against the machine carefully.

NOTE

Make sure the pins of the front door do not touch the legs of the auger support.

- K. Secure the front door to the machine by placing the knobs on the studs and tightening until finger tight. Tighten in a crisscross pattern. Do not overtighten. Proper o-ring seal can be observed through the transparent front door.

3.8 SANITIZING

Sanitizing must be done after the machine is clean and just before the machine is filled with mix. Sanitizing the night before does not ensure sanitization the next day. However, you should always clean the machine and parts after using it.

NOTE

The United States Department of Agriculture and the Food and Drug Administration require that all cleaning and sanitizing solutions used with food processing equipment be certified for this use.

When sanitizing the machine, refer to local sanitary regulations for applicable codes and recommended sanitizing products and procedures. The frequency of sanitizing must comply with local health regulations. Mix sanitizer in quantities of no less than 2 gallons of 90°F to 110°F (32°C to 43°C) water. Allow sanitizer to contact the surfaces to be sanitized for 5 minutes. Any sanitizer must be used only in accordance with the manufacturer's instructions and provide a 100 parts per million strength solution.

- A. Prepare 2 gallons of Stera-Sheen sanitizing solution following the manufacturer's instructions.
- B. Install the mix inlet regulator into the hopper.
- C. Pour the sanitizing solution into the hopper.
- D. Place the switch in the CLEAN position.
- E. Check for leaks.
 - 1. Check for leaks at the front door seal.
 - 2. Check the drain tray located under the front door for leaks coming from the rear of the rear auger seal.
- F. Use a sanitized soft bristle brush dipped in sanitizing solution to clean the hopper sides, the mix inlet regulator, and the underside of the hopper cover.
- G. After the five minutes, open the spigot to drain the sanitizing solution.
- H. Place the switch in the OFF position. Allow the freezing cylinder to drain completely.

The machine is now sanitized and ready for adding mix.

3.9 FREEZE DOWN AND OPERATION

- A. Sanitize immediately before use.
- B. Fill the hopper with at least 2.5 gallons of mix.
- C. Place a container under the spigot and open the spigot to allow the mix to flush out about 8 ounces (0.23 liters) of sanitizing solution and liquid mix.
- D. Allow the freezing cylinder to fill at least halfway. Then place the switch in the ON position.
- E. After 8 to 12 minutes, the product will be at consistency and will be ready to serve. Freeze down time may vary depending on mix type and ambient temperatures.
- F. To dispense, pull the spigot handle down to open.

- G. The machine dispenses product at a reasonable draw rate. If the machine is overdrawn, the result is a soft product or a product that will not dispense at all. If this occurs, allow the machine to run for approximately 30 seconds before dispensing more product. A dispense rate adjustor is located under the header panel, to the immediate right of the spigot handle. Turning the knob counterclockwise decreases the dispense rate.
- H. Do not operate the machine when the ADD MIX light is on. Refill the hopper immediately.

3.10 MIX INFORMATION

Mix can vary considerably from one manufacturer to another. Differences in the amount of butterfat content and quantity and quality of other ingredients have a direct bearing on the finished frozen product. A change in machine performance that cannot be explained by a technical problem may be related to the mix.

Proper product serving temperature varies from one manufacturer's mix to another. Shake mixes generally provide a satisfactory product in the 24°F to 28°F (0.5°C to 2.2°C) range. Diet and low-carb mixes typically freeze to proper consistency at higher temperatures.

When checking the temperature, stir the thermometer in the frozen product to get an accurate reading.

Old mix, or mix that has been stored at too high a temperature, can result in a finished product that is unsatisfactory. To retard bacteria growth in dairy based mixes, the best storage temperature range is between 33° to 38°F (0.5° to 3.3° C).

SECTION 4 MAINTENANCE AND ADJUSTMENTS

This section is intended to provide maintenance personnel with a general understanding of the machine adjustments. It is recommended that any adjustments be made by a qualified person.

WARNING

Hazardous Voltage

Make sure the machine is off when disassembling for servicing. The machine must be disconnected from electrical supply before removing any access panel. Failure to disconnect power before servicing could result in death or serious injury.

4.1 TEMPERATURE ADJUSTMENT

The Temperature Adjustment Screw is located under the header panel. It is used to make the product warmer or colder. Making product colder also increases product consistency (thicker product) and vice versa.

When setting the temperature, adjust the screw 1/8 of a turn and retest before making another adjustment (use the markings on the decal on the underside of the header panel). Turn it to the right to make product colder or to the left to make product warmer.

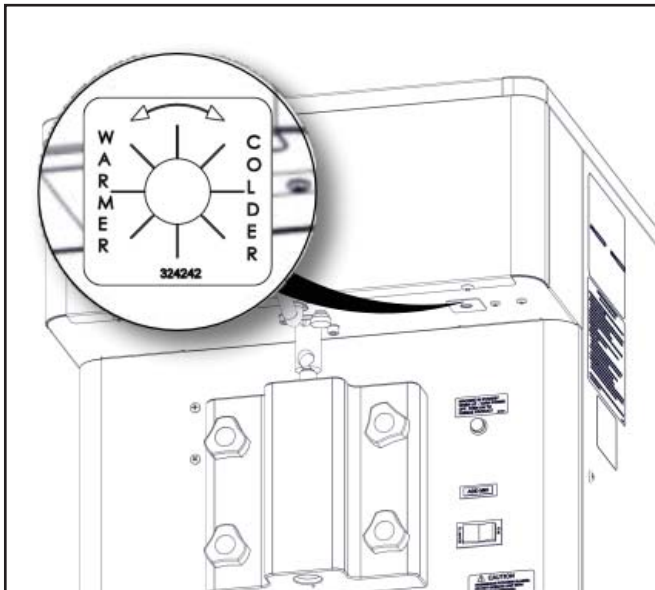

Figure 4-1 Temperature Adjustment

4.2 DRIVE BELT TENSION ADJUSTMENT

To check the belt tension, follow the steps below:

- A. Disconnect power to the machine.
- B. Remove the rear panel and left side panel.

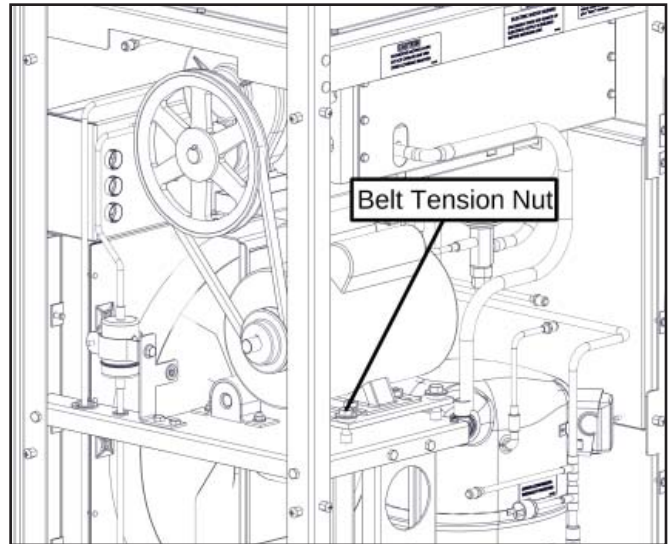

Figure 4-2 Belt Tension

- C. Use a Burroughs belt Tension Gauge to set the tension for the drive belt. Set the belt tension to 45-55 lbs.
- D. If an adjustment is necessary, adjust the belt tension nut. Make sure the other motor plate nut is snug.

NOTE

Belt life will be increased if new drive belts are tightened after two or three weeks of operation.

4.3 CONDENSER CLEANING (AIR-COOLED MACHINES)

The condenser requires periodic cleaning. If it is not kept clean, refrigeration efficiency will be lost. To clean the condenser, refer to the following procedures.

- A. Disconnect power to the machine
- B. Remove the Phillips head screws from the right side panel, and remove the panel.
- C. To remove a condenser filter, grasp the top and pull off. Visually inspect the filters for dirt. If a filter is dirty, shake or brush excess dirt off the filter and wash it in warm, soapy water. Once it is clean, rinse it thoroughly in warm, clear water and shake dry, taking care not to damage the filter in any way.

4.4 PREVENTIVE MAINTENANCE

It is recommended that a preventative maintenance schedule be followed to keep the machine clean and operating properly. The following steps are suggested as a preventative maintenance guide.

A. DAILY

Check for any unusual noise or condition and repair immediately.

B. MONTHLY

Check the condenser filter for dirt and clean if necessary.

C. QUARTERLY CHECKS

Check drive belt for wear and tighten belt if necessary.

4.5 EXTENDED STORAGE

Refer to the following steps for storage of the machine over any long period of shutdown time:

- A. Thoroughly clean all parts that come in contact with mix with warm detergent water. Rinse in clear water and dry all parts. Do not sanitize.

NOTE

Do not let the cleaning solution stand in the hopper or in the freezing cylinder during the shutdown period.

- B. Remove, disassemble, and clean the front door, and auger shaft. Leave disassembled during the shutdown period.
- C. Place the auger flights and auger support bushing in a plastic bag with a moist paper towel. This prevents them from becoming brittle if exposed to dry air over an extended period of time (over 30 days).
- D. For water-cooled machines that are left in unheated buildings, or buildings subject to freezing, the water must be shut off and disconnected. Disconnect the water inlet fitting. The fitting is located at the rear of the machine. Run the compressor for 2 - 3 minutes to open water valve (the front door must be attached for the compressor to run). Blow out all water through water inlet. Drain the water supply line coming to the machine. Disconnect the water outlet fitting.
- E. Place the CLEAN-OFF-ON switch in the OFF (middle) position.
- F. Disconnect the machine from the electrical supply source.

SECTION 5 TROUBLESHOOTING

5.1 LIGHT INDICATORS

The machine has two lights that will alert the user if a problem occurs: an ADD MIX light and a Diagnostic Light.

The ADD MIX light will flash to alert the operator to a low mix condition. It does so by monitoring the mix level in the hopper. When the ADD MIX light is flashing, refill hopper immediately.

The Diagnostic Light will flash if an error occurs. Refer to the chart below for details.

Indication	On	One Blink	Two Blinks	Three Blinks
Conditions	Standby Mode	Torque is not met after 22 minutes	Drive current is not sensed	Machine left in clean mode for over 20 minutes
Self Correction	N/A	N/A	The machine attempts to sense drive current with a 3 second pre-stir. If current is sensed, the machine will return to normal operation. If current is not sensed, the machine will wait 7 minutes and try to sense current with another 3 second pre-stir. After the third attempt, the compressor will run on timers.	N/A
Operation	Every 10 minutes the machine will run for 30 seconds.	Timers or until the consistency sensor is satisfied.	Timers	Off
Corrective Action	Standby Mode ends when the spigot is opened or when the CLEAN-OFF-ON switch is moved to OFF position then to the ON position	Check the condenser (Section 3.13). Make sure the auger is installed correctly (Section 3.11). Contact Service Technician	Contact Service Technician	Turn CLEAN-OFF-ON switch to OFF (middle) position then turn the switch to ON.

5.2 TROUBLESHOOTING

PROBLEM	POSSIBLE CAUSE	REMEDY
Machine does not run.	<ol style="list-style-type: none"> 1 Power to machine is off. 2 Blown fuse or tripped circuit. 3 Freeze-up (auger will not turn). 4 Front door not in place. 	<ol style="list-style-type: none"> 1 Supply power to machine. 2 Replace or reset. 3 Turn Clean/Off/On switch Off for 15 minutes, then restart. 4 Assemble front door in place.
Product is too firm.	<ol style="list-style-type: none"> 1 Temperature setting is too cold. 	<ol style="list-style-type: none"> 1 Adjust the Temperature Adjustment Screw (Section 3.2)

5.2 TROUBLESHOOTING - CONTINUED

PROBLEM	POSSIBLE CAUSE	REMEDY
Product is too thin.	<ol style="list-style-type: none"> 1 Temperature setting too warm. 2 No vent space for free flow of cooling air. 3 Condenser is dirty. 4 Auger is assembled incorrectly. 5 Refrigeration problem. 	<ol style="list-style-type: none"> 1 Adjust the Temperature Adjustment Screw (Section 3.2) 2 A minimum of 3" of air space at the sides. 3 Clean the condenser. (See Section 3.13) 4 Remove mix, clean, reassemble, sanitize and freeze down. 5 Check system. (Call a service technician)
Product does not dispense or it is a very slow draw rate.	<ol style="list-style-type: none"> 1 No mix in hopper. 2 Auger is not turning 3 Mix inlet regulator is obstructed or clogged. 4 Front door has frozen product or is clogged. 	<ol style="list-style-type: none"> 1 Add mix to the hopper 2 Check system. (Call a service technician) 3 Clean the mix inlet regulator and make sure the mix is fully thawed. 4 Turn Clean/Off/On switch to Clean for 5 minutes, then restart.
Drive belt slipping or squealing.	<ol style="list-style-type: none"> 1 Not tensioned properly. 2 Worn drive belt. 3 Freeze-up (Auger will not turn). 	<ol style="list-style-type: none"> 1 Adjust belt tension 2 Replace drive belt. 3 Turn Clean/Off/On switch Off for 15 minutes, then restart.
Rear auger seal leaks.	<ol style="list-style-type: none"> 1 Outside surface of rear auger seal is lubricated. 2 Rear seal missing or damaged. 3 Seal o-ring missing or damaged. 4 Worn or scratched auger shaft. 	<ol style="list-style-type: none"> 1 Clean lubricant from outside of rear seal and rear of the freezing cylinder. Lubricate the rear seal o-ring and reinstall the auger (See Section 3.11) 2 Check or replace. 3 Check. or replace. 4 Replace auger shaft.
Front door leaks.	<ol style="list-style-type: none"> 1 Front door knobs are loose. 2 Spigot o-rings are not lubricated. 3 Chipped or worn spigot o-rings. 4 Inner spigot hole in front door nicked or scratched. 	<ol style="list-style-type: none"> 1 Tighten knobs in a crisscross pattern. 2 Lubricate the spigot o-rings 3 Replace o-rings. 4 Replace front door.

SECTION 6 REPLACEMENT PARTS

6.1 BRUSHES, DECALS, AND LUBRICATION

Part	Description	Quantity
C-1000-26C	Decal - Made In USA	1
208135	Brush - 4" X 8" X 16" (Barrel)	1
208380	Brush - 1/4" X 3" X 14"	1
208401	Brush - 1" X 3" X 10"	1
208410	Brush - 1-1/2" X 4" X 12"	1
324065	Decal - Water Inlet	1
324105	Decal - Caution Electrical Shock	6
324106	Decal - Caution Electrical Wiring Materials	1
324107	Decal - Caution Hazardous Moving Parts	3
324141	Decal - Caution Rotating Blades	1
324200	Decal - High Pressure Cut-Out	1
324208	Decal - Attention Refrigerant Leak Check	2
324242	Decal - Temperature Adjustment	1
324509	Decal - Cleaning Instructions	1
324566	Decal - Wired According To	1
324584	Decal - Adequate Ventilation 3"	2
324803	Decal - Domed Stoelting Logo (Large) (Header Panel)	1
324804	Decal - Domed Stoelting Swirl (Header Panel)	1
324865	Decal - Standby Light	1
324927	Decal - Motor Compressor Thermally Protected	1
325023	Decal - Stoelting (Black) (Large) (Header Panel)	1
325024	Decal - Stoelting (Black) (Small) (Drip Tray)	1
508053	Lubricant - Total Blend (50 Packets)	1

6.2 AUGER SHAFT AND FACEPLATE PARTS

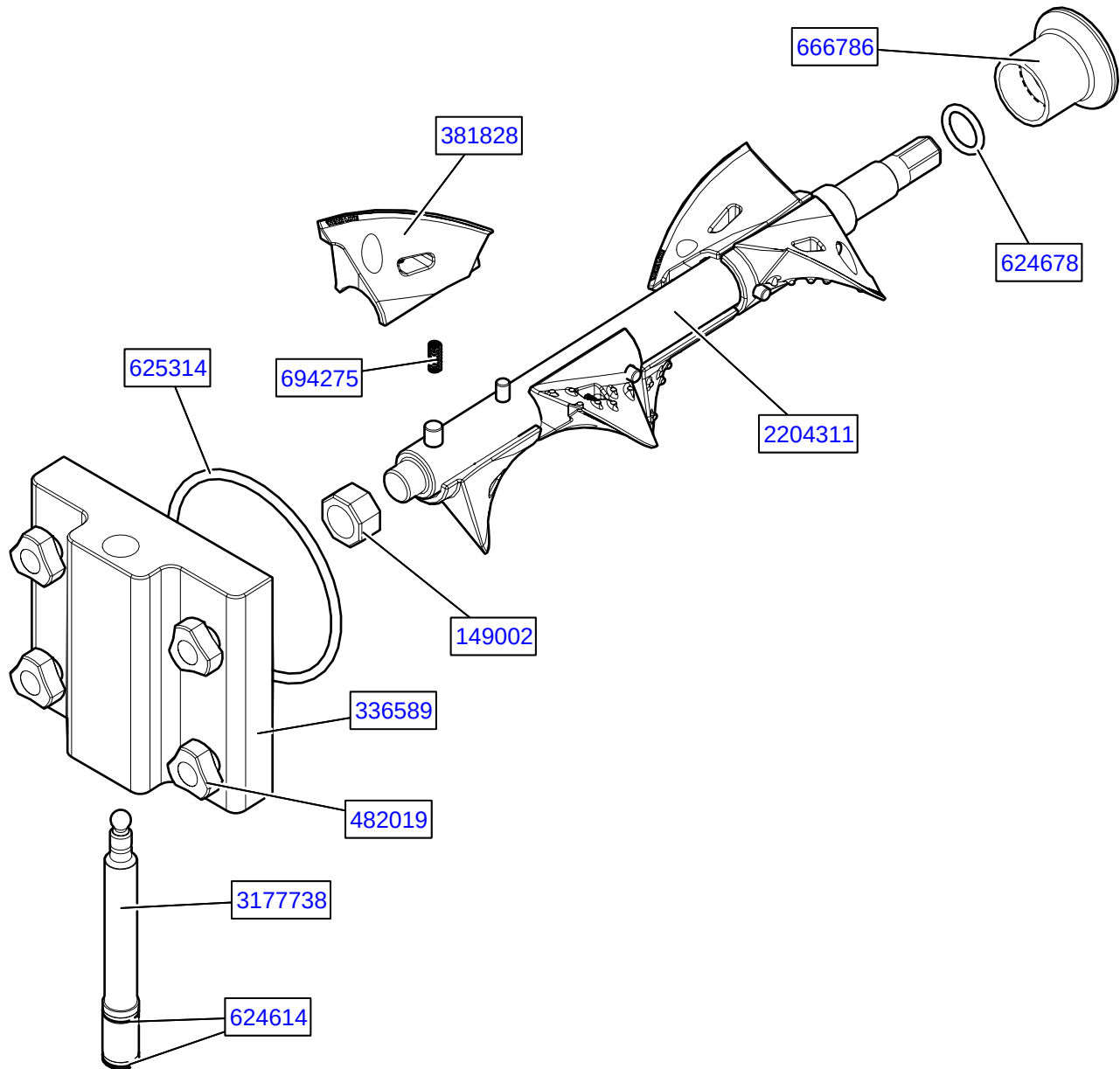

Part	Description	Quantity
149002	Bushing - Front Auger Support	1
336589	Door - Front	1
381828	Auger Flight	6
482019	Knob - Front Door (Black)	4
624614-5	O-Ring - Spigot (5 Pack)	2
624678-5	O-Ring - Rear Seal - Black (5 Pack)	1
625314	O-Ring - Front Door - Black	1
666786	Seal - Rear Auger - Black	1
694275	Spring - Auger Flight	6
2204311	Auger Shaft	1
3177738	Spigot Body	1

6.3 HOPPER PARTS

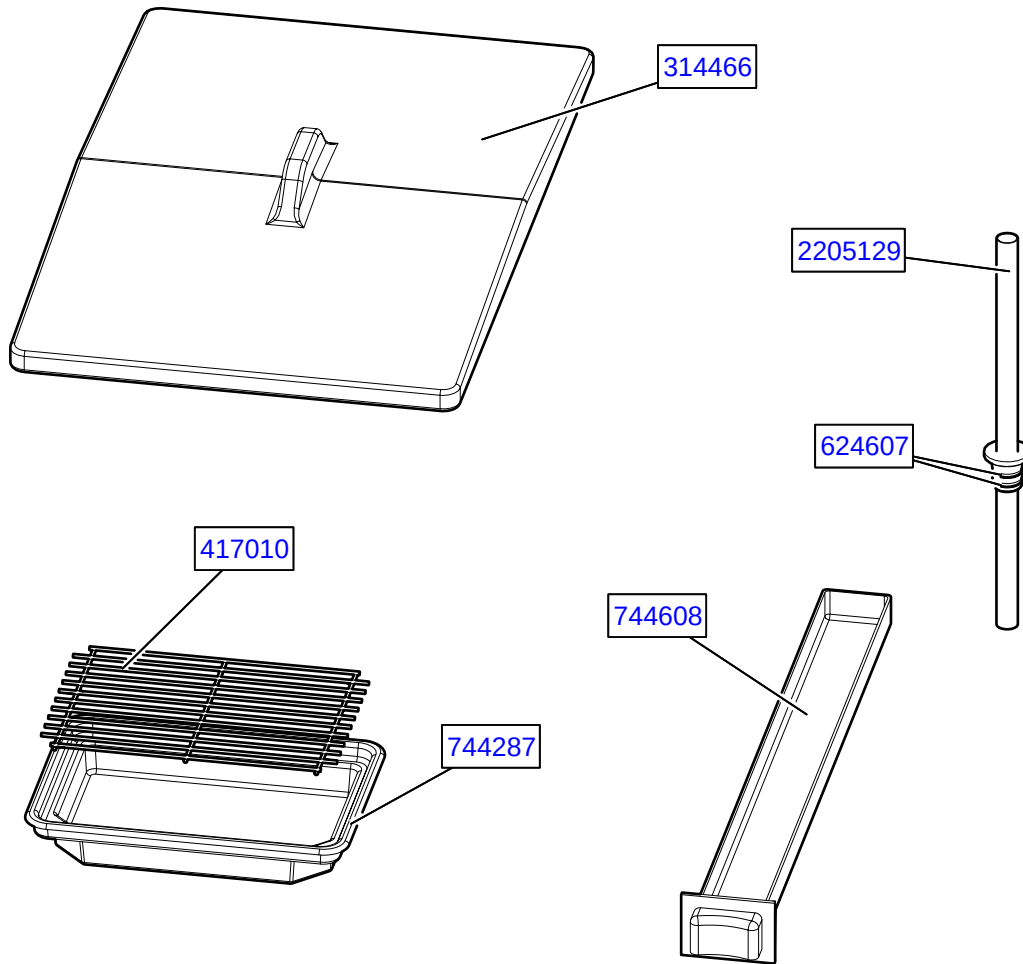

Part	Description	Quantity
314466	Cover - Hopper	1
417010	Grid - Drip Tray	1
624607-5	O-Ring - Mix Inlet (5 Pack)	2
744287	Tray - Drip	1
744608	Tray - Drain	1
2205129	Mix Inlet Assembly	1

1. Scope:

Stoelting, A Vollrath Company (“Stoelting”) warrants to the first user (the “Buyer”) that the Stoelting-branded freezer equipment (the “Equipment”) will be free from defects in materials and workmanship under normal use and proper maintenance for the period listed below in the Warranty Period section. All warranty periods begin on the date of original install or one (1) year from the shipping date, whichever occurs first. This warranty is subject to all conditions, exceptions, and limitations contained herein.

2. Disclaimer of Other Warranties:

THIS WARRANTY IS EXCLUSIVE; AND STOELTING HEREBY DISCLAIMS ANY IMPLIED WARRANTY OF MERCHANTABILITY OR FITNESS FOR PARTICULAR PURPOSE.

3. Remedies:

Stoelting’s sole obligations, and Buyer’s sole remedies, for any breach of this warranty shall be, at Stoelting’s option, one of the following: repair or replacement of the affected component at Stoelting’s plant in Kiel, Wisconsin, or refund of the purchase price of the affected Equipment. Stoelting, through an Authorized Stoelting Provider, will deinstall/reinstall the affected component from/into the equipment (“Labor”) for the period listed below in the Warranty Period section. These obligations/remedies are subject to the conditions that Buyer (a) signs and returns to Stoelting, upon installation, the Start-Up and Training Checklist for the affected equipment, (b) gives Stoelting prompt written notice of any claimed breach of warranty within the applicable warranty period, and (c) delivers the affected equipment to Stoelting or its designated service location, in its original packaging/crating, also within that period. Buyer shall bear the cost and risk of shipping to and from Stoelting’s plant or designated service location.

4. Warranty Period:

Equipment	Part	Part Warranty Period	Labor Warranty Period
Soft Serve & Shake	Freezing Cylinders	Five (5) Years	Twelve (12) Months
	Hoppers		
	Compressors		
	Drive Motors		
	Speed Reducers		
	Augers		
Frozen Uncarbonated Beverage	Evaporator	Five (5) Years	Twelve (12) Months
	Compressors		
	Drive Motors		
	Speed Reducers		
Custard & Batch	Freezing Cylinders	Two (2) Years	Twelve (12) Months
	Hoppers		
	Compressors		
	Drive Motors		
	Speed Reducers		
	Beaters Auger Shafts		
Dipping Cabinets & Display Cabinets	All components	Twelve (12) Months	Twelve (12) Months
Frozen Beverage / Granita Dispenser	Compressors	Five (5) Years	Twelve (12) Months
	Electronic Board	Three (3) Years	
	All other components	Two (2) Years	
AutoVend	All components	Twelve (12) Months	Twelve (12) Months
Crème Whippers	Compressors	Two (2) Years	Twelve (12) Months
	Motors		
	Condensers		
All equipment	All other components not specified above	Twelve (12) Months	Twelve (12) Months

5. **Conditions:**

- a) If the date of the original installation cannot be verified, these warranty periods begin one (1) year from the shipping date. It is the responsibility of the seller to disclose this information to the Buyer at the time of sale.
- b) Stoelting shall not be responsible to provide any remedy under this warranty with respect to any component that fails by reason of negligence, abnormal use, misuse or abuse, faulty repair made by others, use with parts or equipment not manufactured or supplied by Stoelting, any modification or alteration of any parts or equipment, or damage in transit.
- c) This warranty is valid only if the Equipment is installed and serviced by an Authorized Stoelting Provider and only if new, genuine Stoelting parts are used.
- d) The Equipment installation location must have suitable conditions as explained in the Stoelting operators manual, specification sheet, and/or technical manual including but not limited to, ambient temperature, water supply parameters, and space requirements.
- e) The Authorized Stoelting Provider must return defective parts, at Stoelting's discretion, for credit.
- f) Any refrigerant other than that specified on the Equipment model identification nameplate voids this warranty.

6. **Exceptions:**

This warranty does **NOT** cover any of the following

- a) Costs associated with installation labor, disposal of equipment being replaced, and shipping costs of replacement parts or Equipment.
- b) Cleaning, maintenance or lubrication of the Equipment as outlined in the Stoelting operators manual.
- c) This warranty does not extend to parts, sometimes called "wear parts", which are generally expected to deteriorate and to require replacement as equipment is used, including but limited to o-rings, auger flights, auger seals, auger support bushings, and drive belts. All such parts are sold **AS IS**.
- d) External components including but not limited to hoses, piping, or electrical equipment.
- e) Labor and travel charges due to return trips or waiting if the Authorized Stoelting Provider is prevented from promptly starting service work upon arrival. This exception includes labor charges incurred for limited access facilities including, but not limited to, government and military buildings, and airports.
- f) Failure, damage, or repairs due to faulty installation, misapplication, abuse, lack of service, or improper service, unauthorized alteration, improper operation as indicated in the Stoelting operators manual, including but not limited to failure to properly assemble and/or clean, improper tool usage, or use of unapproved lubrication, or cleaning and sanitizing supplies.
- g) Any costs associated with electricity, including utility increases, from any reason whatsoever.
- h) Damage resulting from the use of refrigerant other than that specified on the Equipment model identification nameplate.
- i) The use of this equipment as a rental asset negates all warranties associated with the equipment.
- j) Any special, indirect or consequential property or commercial damage of any nature whatsoever, if the jurisdiction allows this exclusion.
- k) Costs not covered by the Stoelting Travel Pay policy. Stoelting covers only the first trip travel which is a flat rate by mileage one-way from the service company's home location to the job site. The flat rate is calculated as follows:
 - o 0-50 Miles \$85
 - o 51-110 Miles \$127
 - o 111-160 Miles \$165
 - o Over 160 Miles The maximum reimbursed by Stoelting is \$165

Any travel costs not covered may be invoiced to the customer.

7. **Limitations:**

THE REMEDIES SET FORTH IN THIS WARRANTY SHALL BE THE SOLE LIABILITY STOELTING AND THE EXCLUSIVE REMEDY OF BUYER WITH RESPECT TO EQUIPMENT SUPPLIED BY STOELTING; AND IN NO EVENT SHALL STOELTING BE LIABLE FOR ANY INCIDENTAL OR CONSEQUENTIAL DAMAGES, INCLUDING AS EXAMPLES BUT NOT INTENDED TO BE LIMITED TO DOWNTIME, OVERHEAD, MATERIALS, PERFORMANCE PENALTIES, LOST SALES, LOST PROFITS, PRODUCT LOSS, OR PROPERTY DAMAGES, WHETHER FOR BREACH OF WARRANTY OR OTHER CONTRACT BREACH, NEGLIGENCE OR OTHER TORT, OR ON ANY STRICT LIABILITY THEORY.