



Model SO212
OPERATORS MANUAL

Manual No. [513610](#)

Apr. 2009

This manual provides basic information about the machine. Instructions and suggestions are given covering its operation and care.

The illustrations and specifications are not binding in detail. We reserve the right to make changes to the machine without notice, and without incurring any obligation to modify or provide new parts for machines built prior to date of change.

DO NOT ATTEMPT to operate the machine until instructions and safety precautions in this manual are read completely and are thoroughly understood. If problems develop or questions arise in connection with installation, operation, or servicing of the machine, contact Stoelting.



stoeltingfoodservice.com

Stoelting Foodservice Equipment
502 Highway 67
Kiel, WI 53042-1600
U.S.A.

Main Tel: 800.558.5807
Fax: 920.894.7029

Customer Service: 888.429.5920
Fax: 800.545.0662
Email: foodservice@stoelting.com

© 2014 PW Stoelting, LLC

A Few Words About Safety

Safety Information

Read and understand the entire manual before operating or maintaining Stoelting equipment.

This manual provides the operator with information for the safe operation and maintenance of Stoelting equipment. As with any machine, there are hazards associated with their operation. For this reason safety is emphasized throughout the manual. To highlight specific safety information, the following safety definitions are provided to assist the reader.

The purpose of safety symbols is to attract your attention to possible dangers. The safety symbols, and their explanations, deserve your careful attention and understanding. The safety warnings do not by themselves eliminate any danger. The instructions or warnings they give are not substitutes for proper accident prevention measures.

If you need to replace a part, use genuine Stoelting parts with the correct part number or an equivalent part. We strongly recommend that you do not use replacement parts of inferior quality.



Safety Alert Symbol:

This symbol Indicates danger, warning or caution. Attention is required in order to avoid serious personal injury. The message that follows the symbol contains important information about safety.

Signal Word:

Signal words are distinctive words used throughout this manual that alert the reader to the existence and relative degree of a hazard.



The signal word “WARNING” indicates a potentially hazardous situation, which, if not avoided, may result in death or serious injury and equipment/property damage.



The signal word “CAUTION” indicates a potentially hazardous situation, which, if not avoided, may result in minor or moderate injury and equipment/property damage.

CAUTION

The signal word “CAUTION” not preceded by the safety alert symbol indicates a potentially hazardous situation, which, if not avoided, may result in equipment/property damage.

NOTE (or NOTICE)

The signal word “NOTICE” indicates information or procedures that relate directly or indirectly to the safety of personnel or equipment/property.

TABLE OF CONTENTS

SECTION	DESCRIPTION	PAGE
1. INTRODUCTION		
1.1	Description	1
1.2	Specifications	2
2. INSTALLATION INSTRUCTIONS		
2.1	Safety Precautions	3
2.2	Shipment and Transit.....	4
2.3	Freezer Installation	4
2.4	Installing Permanent Wiring	5
3. INITIAL SET-UP AND OPERATION		
3.1	Operator's Safety Precautions	7
3.2	Operating Controls and Indicators.....	7
3.3	Sanitizing	8
3.4	Freeze Down and Operation.....	9
3.5	Mix Information	10
3.6	Removing Mix From Freezer	10
3.7	Cleaning The Freezer	11
3.8	Disassembly of Freezer Parts	11
3.9	Cleaning The Freezer Parts	12
3.10	Sanitize Freezer and Freezer Parts	12
3.11	Assembly of Freezer	13
3.12	Routine Cleaning	13
3.13	Preventive Maintenance	15
3.14	Extended Storage	15
4. TROUBLESHOOTING	19
5. REFERENCE DRAWINGS	19

LIST OF ILLUSTRATIONS

FIGURE	TITLE	PAGE
1-1	Model SO212 Freezer	1
1-2	Specifications	1
2-1	Warning Label Locations	3
2-2	Leveling	4
2-3	Space and Ventilation Requirements	4
2-4	Electrical Plug	4
2-5	Power Cord Connection	5
3-1	Controls	7
3-2	Mix Inlet Regulator	9
3-3	Sanitizing Hopper	9
3-4	Dispensing Product	10
3-5	Removing Blender	11
3-6	Removing Auger Shaft	12
3-7	Removing O-Ring	12
3-8	Cleaning Freezer Barrel	12
3-9	Auger and Door Assembly	13
5-1	Replacement Parts	19

SECTION 1 DESCRIPTION AND SPECIFICATIONS

1.1 DESCRIPTION

The Stoelting SO212 floor model freezer is gravity fed. The freezer is equipped with fully automatic controls to provide a uniform product. The freezer is designed to operate with almost any type of commercial shake mix available. This manual is designed to assist qualified service personnel and operators in the installation, operation and maintenance of the Stoelting Model SO212 freezer.



Figure 1-1 Model SO212 Freezer

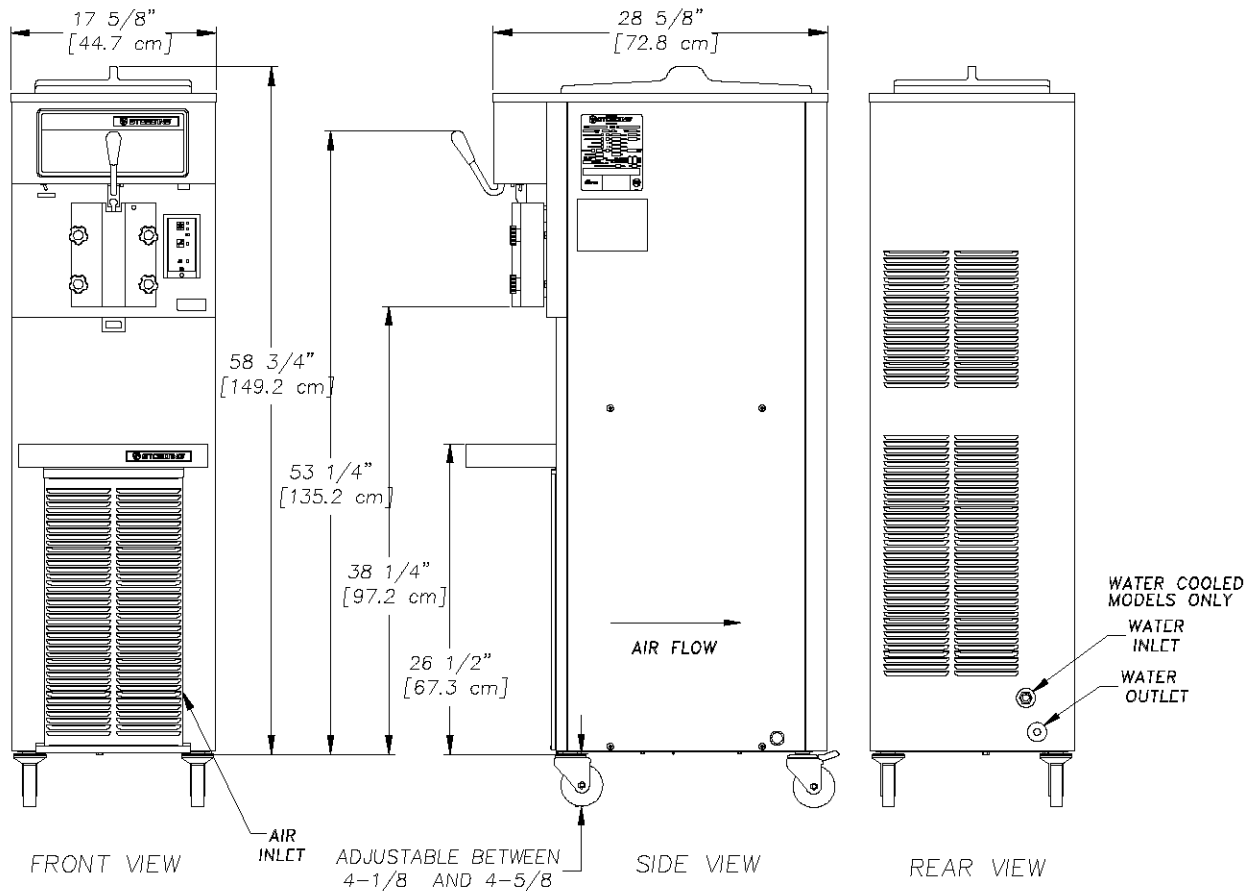

Figure 1-2 Specifications

MODEL SO212
FLOOR MODEL
GRAVITY SHAKE FREEZER

1.2 SPECIFICATIONS

DIMENSIONS:

Freezer: 17.6" (45cm) wide x 28.6" (73cm) deep x 63.75" (162cm) high
Crated: 19.5" (50cm) wide x 33" (84cm) deep x 40" (102cm) high

WEIGHT:

Freezer: 332 lbs. (150kg) Crated: 427 lbs. (193kg)

ELECTRICAL:

Description SO212-38
Voltage AC 1 PH 208/230
Total Run Amps 10.5
Drive Motor 3/4 HP
Compressor 12,000 BTUH (90°F - 0°F)

Use 20 amp HACR circuit breaker.

Automatic safeguard circuit built into electronic control - protects major freezer components under abnormal operating conditions.

COOLING:

Air cooled requires minimum 3" (7.6cm) air clearance on back side.
No clearance needed on sides.

HOPPER:

7 Gallons (26,5 liters) refrigerated and insulated.

SECTION 2 INSTALLATION INSTRUCTIONS

2.1 SAFETY PRECAUTIONS

Do not attempt to operate the freezer until the safety precautions and operating instructions in this manual are read completely and are thoroughly understood.

Take notice of all warning labels on the freezer. The labels have been put there to help maintain a safe working environment. The labels have been designed to withstand washing and cleaning. All labels must remain legible for the life of the freezer. Labels should be checked periodically to be sure they can be recognized as warning labels.

If danger, warning or caution labels are needed, indicate the part number, type of label, location of label, and quantity required along with your address and mail to:

STOELTING, INC.
ATTENTION: Customer Service
502 Hwy. 67
Kiel, Wisconsin 53042

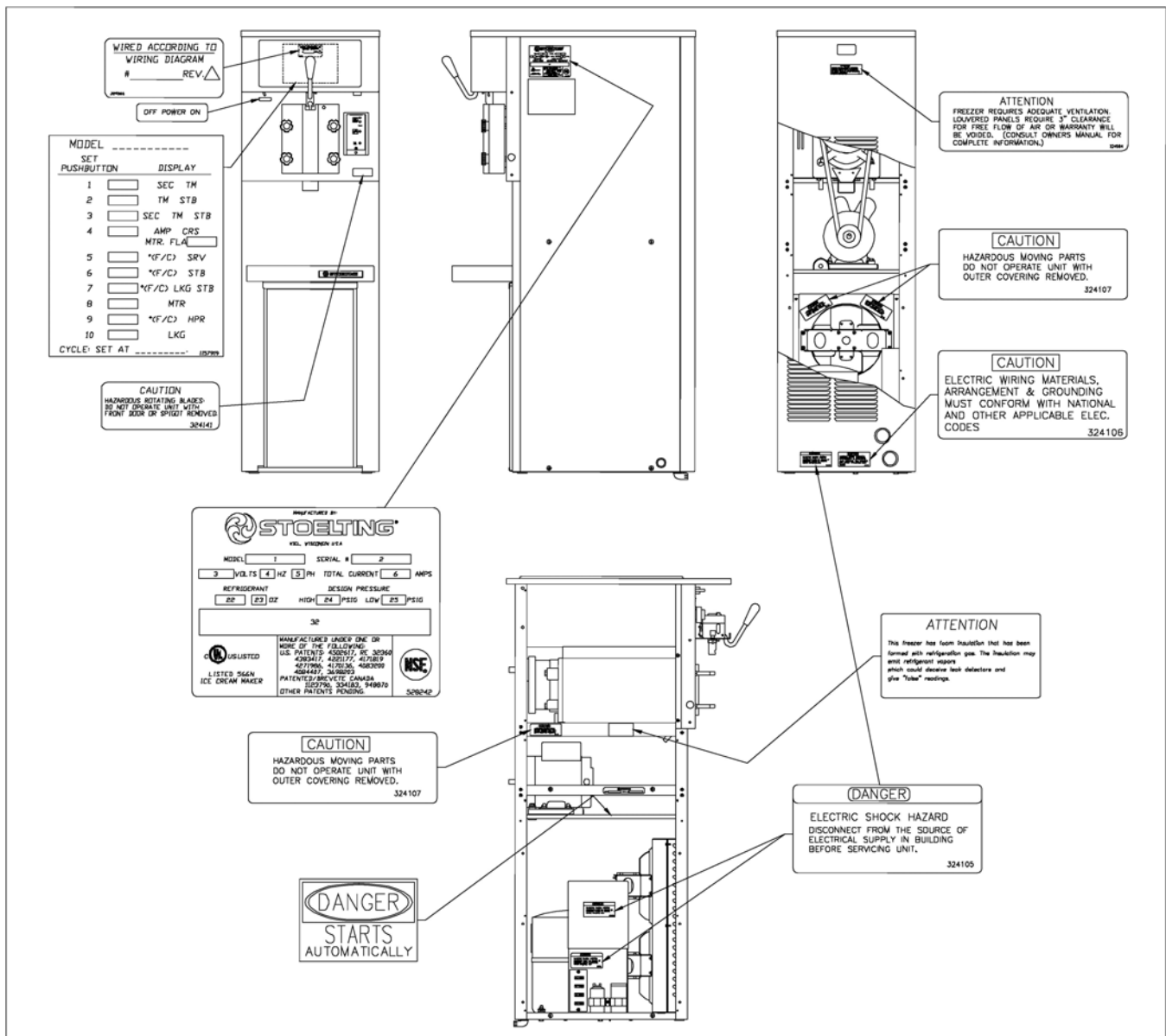

Figure 2-1 Warning Label Locations

2.2 SHIPMENT AND TRANSIT

The freezer has been assembled, operated and inspected at the factory. Upon arrival at the final destination, the complete freezer must be checked for any damage which may have occurred during transit.

With the method of packaging used, the freezer should arrive in excellent condition. **THE CARRIER IS RESPONSIBLE FOR ALL DAMAGE IN TRANSIT, WHETHER VISIBLE OR CONCEALED.** Do not pay the freight bill until the freezer has been checked for damage. Have the carrier note any visible damage on the freight bill. If concealed damage and/or shortage is found later, advise the carrier within 10 days and request inspection. The customer must place claim for damages and/or shortages in shipment with the carrier. Stoelting, Inc. cannot make any claims against the carrier.

2.3 FREEZER INSTALLATION

Installation of the freezer involves moving the freezer close to its permanent location, removing all crating, setting in place, assembling parts, and cleaning.

- A. Uncrate the freezer.
- B. Accurate leveling is necessary for correct drainage of freezer barrel and to insure correct overrun. Place a level on top of the freezer at each corner to check for level condition. If adjustment is necessary, level the freezer by turning the caster in or out and tighten the locknut. (Fig 2-2).



Figure 2-2 Leveling

- C. The freezer is equipped with an air cooled condenser and requires correct ventilation. The front of the freezer is the air intake and the back discharge. Both front and back must have a minimum of 3" of clearance. (Fig 2-3).

CAUTION

Failure to provide adequate ventilation will void warranty.

- D. Place the OFF-ON switch in the OFF position.

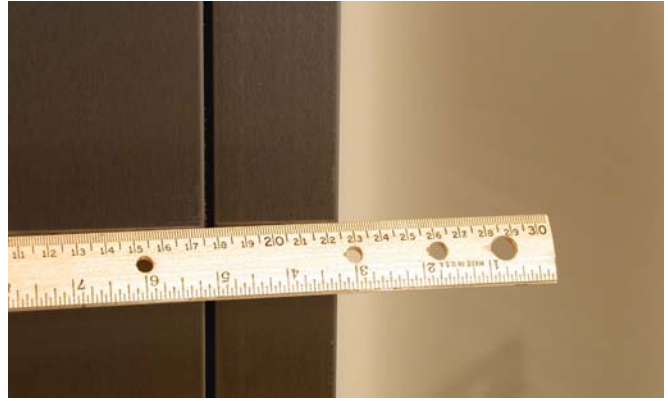

Figure 2-3 Space and Ventilation Requirements

- E. Connect the power cord. The plug is designed for 208 or 230 volt/20 amp duty. Check the nameplate on your freezer for proper supply. The unit must be connected to a properly grounded receptacle. The electrical cord furnished as part of the freezer has a three prong grounding type plug (Fig. 2-4). The use of an extension cord is not recommended, if necessary use one with a size 12 gauge or heavier with ground wire. Do not use an adapter to get around grounding requirement.



Figure 2-4 Electrical Plug

CAUTION

Do not alter or deform the plug in any way.

- F. Install the drip tray, drain tray, hopper cover and other miscellaneous parts on the freezer.

2.4 INSTALLING PERMANENT WIRING

If permanent wiring is required by local codes, the following procedure must be performed.

WARNING
Disconnect freezer from the source of electrical supply before servicing.

- A. Remove the left side panel and electrical box cover.
- B. Disconnect the wires from the terminal block. Disconnect the green ground wire from the grounding stud. (Fig 2-5).
- C. Remove the power cord.
- D. Install permanent wiring according to local code.
- E. Replace the electrical box cover and left side panel.

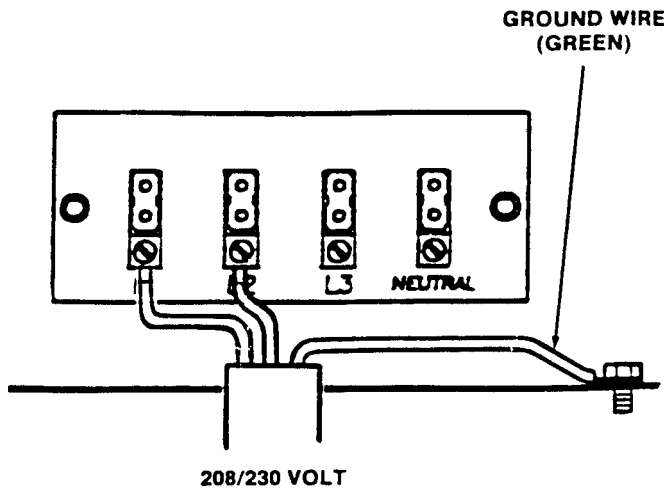

208/230 VOLT
Figure 2-5 Power Cord Connections

SECTION 3 INITIAL SETUP AND OPERATION

3.1 OPERATOR'S SAFETY PRECAUTIONS

Safe operation is no accident; observe these rules:

- A. Know the freezer. Read and understand the operating instructions.
- B. Notice all warning labels on the freezer.
- C. Wear proper clothing. Avoid loose fitting garments, and remove watches, rings or jewelry which could cause a serious accident.
- D. Maintain a clean work area. Avoid accidents by cleaning up the area and keeping it clean.
- E. Stay alert at all times. Know which switch, button or control you are about to use and what effect it is going to have.
- F. Disconnect electrical cord for maintenance. Never attempt to repair or perform maintenance on the freezer until the main electrical power has been disconnected.

- G. Do not operate under unsafe operating conditions. Never operate the freezer if unusual or excessive noise or vibration occurs.

3.2 OPERATING CONTROLS AND INDICATORS

Before operating the freezer, it is required that the operator know the function of each operating control. Refer to Figure 3-1 for the location of the operating controls on the freezer. For the information regarding flashing indicator lights, refer to Section 4 - Troubleshooting.



The Power OFF-ON switch must be placed in the OFF position when disassembling for cleaning or servicing. The freezer must be disconnected from electrical supply before removing any access panel.

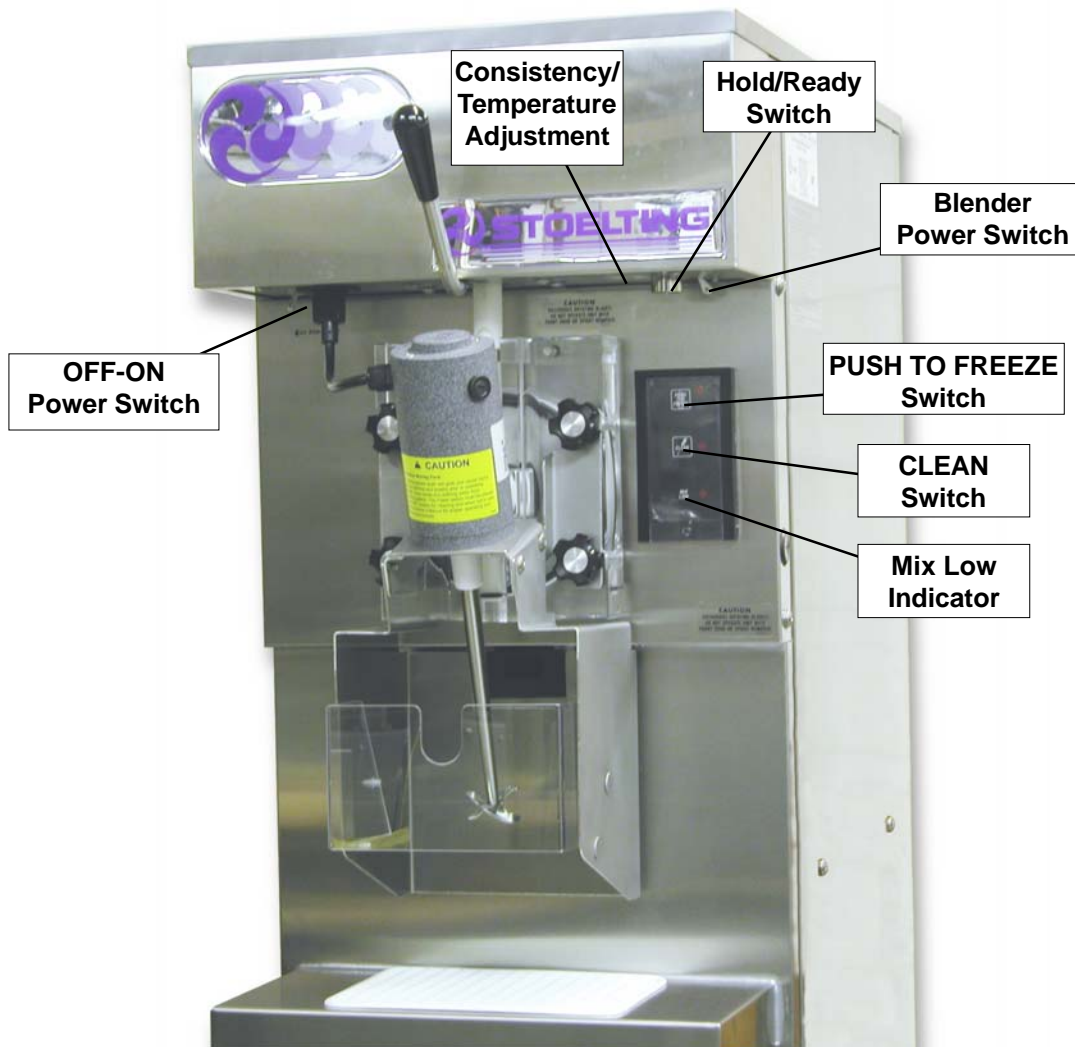

Figure 3-1 Controls

A. SPIGOT SWITCH

The spigot switch will automatically activate the auger drive and refrigeration systems when the spigot is opened to dispense product (pulled straight downwards). When the spigot is closed, the drive motor and compressor will remain “on” until the product in the barrel reaches the proper temperature.

The spigot switch will also activate the blender when pushed to the right (spring loaded). The blender will operate when product is being dispensed or when the spigot is closed.

B. POWER OFF-ON SWITCH

The Power OFF-ON switch is a two position toggle switch used to supply power to the control circuit. When the switch is in the OFF position, nothing will run. When the switch is in the ON position the freezer will be in the idle mode until a switch on the control panel is activated.

C. BLENDER OFF-ON SWITCH

The Blender OFF-ON switch is a two position toggle switch used to supply power to the blender. When the switch is in the OFF position, there is no power to the blender. When the switch is in the ON position the blender will operate any time the spigot handle is pushed to the right.

D. PUSH TO FREEZE BUTTON

The PUSH TO FREEZE button is used to start the freezing cycle. During initial freeze down, the Power OFF-ON switch is placed in the ON position. Then the PUSH TO FREEZE button is pressed until the drive motor and compressor are activated.

NOTE

After the drive motor starts, there is a 3 second delay before the compressor starts.

During the normal operation, the red PUSH TO FREEZE light will illuminate after the freezer has been idle for the preset cycles. Before drawing product, press the PUSH TO FREEZE button if it is illuminated. Wait until the green light illuminates before dispensing.

NOTE

If the freezer shuts off and the PUSH TO FREEZE light flashes, an error condition has occurred. Turn the Power OFF-ON switch to the OFF position, correct the problem and turn the freezer back on. (See Section 4 - Troubleshooting.)

E. GREEN LIGHT

The green light is used to indicate that the product has reached the proper temperature and is ready to be dispensed.

NOTE

If the red light next to the PUSH TO FREEZE button is illuminated, press the PUSH TO FREEZE button and wait until the green light illuminates before dispensing.

F. CLEAN BUTTON

When the CLEAN button is pushed the refrigeration system will be off and the auger will rotate for cleaning. When the button is pushed again, the auger will stop and the clean light will flash indicating the freezer is in the clean mode. To exit the clean mode place the Power OFF-ON switch in the OFF position. If the freezer is left in clean for more than 30 minutes or the CLEAN button is pushed three times in ten seconds, an error will occur. To reset, press the CLEAN switch and allow the error light to flash a minimum of 10 minutes. Then place the Power OFF-ON switch in the OFF position, wait 5 seconds and place the switch in the ON position.

G. DRIVE MOTOR OVERLOAD

The internal drive motor overload will trip if the drive motor is overloaded. It will reset after approximately 10-12 minutes. If the drive motor continues to trip, refer to Section 4 - Troubleshooting.

H. RED MIX LOW LIGHT

The red mix low light is designed to alert the operator to a low mix condition. The light will illuminate with approximately one gallon of mix in the hopper. When the mix low light is illuminated, refill hopper immediately.

NOTE

Failure to refill hopper immediately may result in operational problems.

I. HOLD READY SWITCH

The hold ready switch is a push button switch. When pushed in and held for 5 seconds, the hold ready mode will be activated. The product will remain ready to serve and the freezer will not go to idle. To return to normal operation push and hold for 5 seconds.

3.3 SANITIZING

Sanitizing must be done after the freezer is cleaned and just before the hopper is filled with mix. Sanitizing the night before is not effective. However, you should always clean the freezer and parts after using it.

WARNING

The United States Department of Agriculture and the food and drug administration require that all cleaning and sanitizing solutions used with food processing equipment be certified for this use.

When sanitizing the freezer, refer to local sanitary regulations for applicable codes and recommended sanitizing products and procedures. The frequency of sanitizing must comply with local health regulations. Mix sanitizer according to manufacturer's instructions to provide a 100 parts per million strength solution. Mix sanitizer in quantities of no less than 2 gallons (7.5 liters) of 120°F water. Allow sanitizer to contact the surfaces to be sanitized for 5 minutes. Any sanitizer must be used only in accordance with the manufacturer's instructions.

NOTE

Stoelting has found that Stera-Sheen Green Label does an effective job of properly sanitizing a shake freezer. We therefore include a sample with each new freezer. Other products may be as effective.

CAUTION

Prolonged contact of sanitizer with freezer may cause corrosion of stainless steel parts.

In general, sanitizing may be conducted as follows:

- A. With the auger in place, install the mix inlet regulator into hopper with air inlet (long) tube toward the front of the freezer (Fig. 3-2).



Figure 3-2 Mix Inlet Regulator

NOTE

It is recommended to sanitize the freezer without the blender assembly installed. Once the freezer has been sanitized, install the blender and sanitize the blender shaft.

- B. Prepare 4 gallons (15 liters) of sanitizing solution following manufacturer's instructions. Set aside a large cup of sanitizer solution to sanitize the blender. Pour the remainder of the solution into hopper.

- C. Place the Power OFF-ON switch in the ON position and press the CLEAN button. Check for leaks.
- D. Clean sides of hopper, mix inlet regulator and underside of hopper cover using a sanitized soft bristle brush dipped in the sanitizing solution (Fig. 3-3).



Figure 3-3 Sanitizing Hopper

- E. After five minutes, place a bucket under the spigot and open spigot to drain sanitizing solution. When solution has drained, press the CLEAN button to stop the auger. Allow the freezer barrel to drain completely.
- F. Install the blender assembly to the front door, plug the blender into the outlet on the freezer, and place the Blender Power OFF-ON switch in the ON position.
- G. Submerge the blender shaft into the large cup with sanitizer solution and push the spigot handle to the right. Allow the blender shaft to be submerged for at least 30 seconds.

3.4 FREEZE DOWN AND OPERATION

This section covers the recommended operating procedures to be followed for the safe operation of the freezer.

- A. Sanitize just prior to use.
- B. Place the Power OFF-ON switch in the OFF position.

NOTE

Make sure the mix inlet regulator and blender assembly are in place before adding mix.

- C. With spigot open, pour approximately 1 gallon (3.8 liters) of fully thawed mix into the hopper. Allow the mix to flush out about 8 ounces (0.23 liters) of sanitizing solution and liquid mix. Close the spigot.

- D. Fill hopper with approximately 5 gallons (19 liters) of pre-chilled (40°F or 4°C) mix.

CAUTION

Do not overfill the hopper. Mix level must not be higher than the air inlet tube on the mix inlet regulator.

- E. The freezer barrel will automatically fill until it is about 1/2 full. If freezer barrel does not fill, check for obstruction in the mix inlet regulator. If freezer barrel fills over 1/2 full, check for leaks at the mix inlet regulator o-ring or check if the mix inlet regulator was installed correctly or that the freezer is level.
- F. Place the Power OFF-ON switch in the ON position. Place the Blender Power OFF-ON switch in the ON position and make sure the blender power plug is connected to the freezer.

WARNING

Hazardous Moving Parts
Blender shaft and agitator can grasp and cause injury. Do not operate blender without protective shield or swing splash shield.

- G. Press the PUSH TO FREEZE button until the freezer starts.

NOTE

After the drive motor starts, there is a 3 second delay before the compressor starts.

- H. After about 7 to 10 minutes the freezer will shut off and the green light will illuminate indicating the product is ready to serve. Freeze down time may be longer for some mixes. High ambient temperatures may extend freeze down time.



Figure 3-4 Dispensing Product

- I. For normal dispensing, pull the spigot handle down. (Fig. 3-4). Push the spigot handle to the right to activate the blender. The blender will operate during dispensing or when the spigot handle is closed.

CAUTION

Refrigeration is automatically activated when the spigot is opened (pulled downwards). Close the spigot completely after dispensing.

- J. The freezer is designed to dispense the product at a reasonable draw rate. If the freezer is overdrawn, the result is a very thin product. If this should occur, allow the freezer to run for approximately 30 seconds before dispensing additional product. After a while the operator will sense or feel when the freezer is beginning to fall behind, and will slow down on the rate of draw so as not to exceed the capacity.
- K. Do not operate the freezer when the mix low light is on or with less than 1-3/4" (4.4 cm) of mix in the hopper. Refill the hopper immediately.

3.5 MIX INFORMATION

Mix can vary considerably from one manufacturer to another. Differences in the amount of butterfat content and quantity and quality of other ingredients have a direct bearing on the finished frozen product. A change in freezer performance that cannot be explained by a technical problem may be related to the mix.

Proper product serving temperature varies from one manufacturer's mix to another. Shake mixes generally provide satisfactory product from 24° to 28°F (-4° to -2°C).

When checking the temperature, stir the thermometer in the frozen product to read the true temperature.

Old mix or mix that has been stored at elevated temperatures will produce poor quality product with a bad taste and unacceptable appearance. To retard bacteria growth in dairy based mixes, the best storage temperature range is between 36° to 40°F (2.2° to 4.4°C).

Some products tend to foam more than others. If foam appears in the hopper, skim off with a sanitized utensil and discard. Periodically, stir the mix in the hopper with a sanitized utensil to help prevent excess foam.

3.6 REMOVING MIX FROM FREEZER

To remove the mix from the freezer, refer to the following steps:

- A. Remove the mix inlet regulator from the hopper by pulling straight up.

- B. Place the Power OFF-ON switch in the ON position and push the CLEAN button to rotate the auger. Allow the mix to agitate in freezer barrel until the mix has become a liquid, about 5 minutes.
- C. Empty mix from the freezer by opening the spigot and draining into a tall cup and discarding mix. Continue drawing mix into the cup until the freezer is empty.
- D. Fill a clean and sanitized tall cup with clean 110°F (43°C) water and submerge blender agitator shaft into water. Activate blender by pulling spigot to the right. Allow blender agitator to run for 10-15 seconds. Repeat using a mild detergent.
- E. Push the CLEAN button to stop the auger rotation.
- F. Place the Blender Power OFF-ON switch into the OFF position and unplug the blender from the freezer.
- G. Place the Power OFF-ON switch in the OFF position.



Figure 3-5 Removing Blender

- H. Remove the knobs on the front door and remove the blender assembly and set aside (Fig. 3-5). When the knobs are removed, mix may drip from the door and barrel into the drip tray.

NOTE

Support the blender with one hand while removing the knobs on the door to prevent the blender from dropping.

- J. Replace the door knobs on the front door.

- K. Remove the clear plastic swing shield from the blender assembly and clean it (Refer to Section 3.9 - Cleaning the Freezer Parts).

3.7 CLEANING THE FREEZER

NOTE

The frequency of cleaning the freezer and freezer parts must comply with local health regulations.

After the mix has been removed from the freezer, the freezer must be cleaned. To clean the freezer, refer to the following steps:

- A. Close the spigot and fill the hopper with 2 gallons (7.5 liters) of tap water.
- B. Place the Power OFF-ON switch in the ON position and press the CLEAN button. The auger will start to rotate.
- C. Allow the water to agitate for approximately 5 minutes.

NOTE

If freezer is left in CLEAN for more than 20 minutes, the display will show an error code.

- D. Open the spigot to drain the water. Remember to place a bucket or container under the spigot to catch the water. When the water has drained, turn the Power OFF-ON switch to the OFF position. Allow the freezer barrel to drain completely.
- E. Repeat Steps A through D using a mild detergent solution.

3.8 DISASSEMBLY OF FREEZER PARTS

CAUTION

Hazardous Moving Parts

Revolving auger shaft can grab and cause injury. Place the Power OFF-ON switch in the OFF position before disassembling for cleaning or servicing.

Inspection for worn or broken parts should be made each time the freezer is disassembled. All worn or broken parts should be replaced to ensure safety to both the operator and the customer and to maintain good freezer performance and a quality product. Frequency of cleaning must comply with the local health regulations.

To disassemble the freezer, refer to the following steps:

- A. Remove hopper cover and drain tray.
- B. Remove the mix inlet regulator from the hopper by pulling straight up.
- C. Remove the front door by turning the circular knobs and then pulling the front door off the studs.

- D. Push the spigot body through the bottom of the front door and remove.
- E. Remove the front auger support and bushing (Fig. 3-6).
- F. Remove the auger assembly from the freezer.
- G. Keep the rear of the auger shaft tipped up once it is clear of the freezer to avoid dropping rear seal.
- H. Remove the scraper blades and the rear seal assembly.
- I. Wipe socket lubricant from the drive end (rear) of the auger with a cloth or paper towel.
- J. Remove all o-rings from parts by first wiping off the lubricant using a clean paper towel. Then squeeze the o-ring upward (Fig. 3-7). When a loop is formed, roll out of the o-ring groove.

CAUTION
Do not use any type of sharp object to remove the o-rings.



Figure 3-7 Removing O-Ring

3.9 CLEANING THE FREEZER PARTS

Place all loose parts in a pan or container and take to the wash sink for cleaning. To clean freezer parts refer to the following steps:

- A. Place all parts in warm mild detergent water and clean with brushes provided. Rinse all parts with clean hot water.

NOTE

If a dishwasher is used, product damage is likely to occur.

- B. Wash the hopper and freezer barrel with warm detergent water and brushes provided. (Fig. 3-8)



Figure 3-8 Cleaning Freezer Barrel

- C. Clean the rear seal surfaces from the inside of the freezer barrel with warm detergent water.
- D. Clean the drip tray and insert with a soap solution. Rinse with clean hot water.

3.10 SANITIZE FREEZER AND FREEZER PARTS

- A. Use a sanitizing solution mixed according to manufacturer's instructions to provide 100 parts per million strength solution. Mix sanitizer in quantities of no less than 2 gallons (7.5 liters) of 120°F water. Allow the sanitizer to contact the surfaces to be sanitized for 5 minutes. Any sanitizer must be used only in accordance with the manufacturer's instructions.
- B. Place all parts in the sanitizing solution, then remove and let air dry.

- C. Using this sanitizing solution and the large barrel brush provided, sanitize the rear of the barrel by dipping the brush in the sanitizing solution and brushing the rear of the barrel.

3.11 ASSEMBLY OF FREEZER

To assemble the freezer parts, refer to the following steps:

NOTE

The United States Department of Agriculture and the Food and Drug Administration require that lubricants used on food processing equipment be certified for this use. Use lubricants only in accordance with the manufacturer's instructions.

- A. Assemble all o-rings onto parts dry, without lubrication. Then apply a thin film of sanitary lubrication (Petrol Gel or equivalent) to exposed surfaces of the o-rings. Apply a thin film of sanitary lubricant to metal part of rear seal. Also apply a thin film of sanitary lubricant inside and outside of the front auger support bushing.

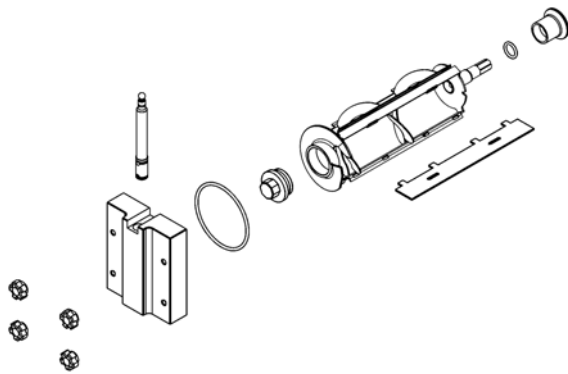

Figure 3-9 Auger and Door Assembly

- B. Assemble the rear seal onto the auger with the large end to the rear. Be sure the o-ring is in place before installing the rear seal.
- C. Lubricate the auger drive (rear) with a small amount of white socket lubricant (spline lubricant). A small container of socket lubricant is shipped with the freezer.
- D. Install the two plastic scraper blades onto the auger and insert it into the freezer barrel.

CAUTION

Do not place the mix inlet regulator into the hopper before installing the auger. Attempting to install the auger with the mix inlet regulator in place will damage the mix inlet regulator.

- E. Rotate the auger until the auger engages the drive shaft.
- F. Install the auger support bushing into the front of the auger.
- G. Install the spigot body with o-ring into the front door from bottom. Push straight up until the spigot is in place.
- H. Install the front door on the freezer.
- I. Install the blender assembly onto the front door studs and tighten the circular knobs on the freezer studs.

CAUTION

Overtightening or uneven tensioning of circular knobs may cause damage to front door and cause leaking. Hand tighten circular knobs evenly.

- J. Look for the proper seal between the freezer barrel, o-ring, and front door.
- K. Install the mix inlet regulator into the freezer with the air tube to the front of the freezer.
- L. Install hopper cover and drain tray.

3.12 ROUTINE CLEANING

To remove spilled or dried mix from the freezer exterior, simply wash in the direction of the finish with warm soapy water and wipe dry. Do not use highly abrasive materials as they will mar the finish.

It is recommended that a maintenance schedule be followed to keep the freezer clean and operating properly.

CLEANING AND SANITIZING INFORMATION

Shake freezers require special consideration when it comes to food safety and proper cleaning and sanitizing.

The following information has been compiled by Purdy Products Company, makers of Stera-Sheen Green Label Cleaner/Sanitizer and specifically covers issues for cleaning and sanitizing frozen dessert machines. This information is meant to supplement a comprehensive food safety program.

SOIL MATERIALS ASSOCIATED WITH FROZEN DESSERT MACHINES

MILKFAT/BUTTERFAT – As components of ice cream/frozen custard mix, these soils will accumulate on the interior surfaces of the machine and its parts. Fats are difficult to remove and help attribute to milkstone build-up.

MILKSTONE – Is a white/gray film that forms on equipment and utensils that come in contact with dairy products. These films will accumulate slowly on surfaces because of ineffective cleaning, use of hard water, or both. Milkstone is usually a porous deposit, which will harbor microbial contaminants and eventually defy sanitizing efforts.

Once milkstone has formed, it is very difficult to remove. Without using the correct product and procedure, it is nearly impossible to remove a thick layer of milkstone. (NOTE: general purpose cleaners DO NOT remove milkstone.) This can lead to high bacteria counts and a food safety dilemma.

IT IS BEST TO CONTROL MILKSTONE ON A DAILY BASIS BEFORE IT CAN BECOME A SIGNIFICANT FOOD SAFETY PROBLEM.

In addition to food safety, milkstone can cause premature wear to machine parts which can add to costs for replacement parts or possibly more expensive repairs if worn machine parts are not replaced once they have become excessively worn.

IMPORTANT DIFFERENCES BETWEEN CLEANING AND SANITIZING

CLEANING vs. SANITIZING

It is important to distinguish between cleaning and sanitizing. Although these terms may sound synonymous, they are not. BOTH are required for adequate food safety and proper machine maintenance.

CLEANING

- Is the removal of soil materials from a surface.
- Is a prerequisite for effective sanitizing.

NOTE

An UNCLEAN surface will harbor bacteria that can defy sanitizing efforts.

Bacteria can develop and resist sanitizing efforts within a layer of soil material (milkstone). Thorough cleaning procedures that involve milkstone removal are critical for operators of frozen dessert machines.

SANITIZING

- Kills bacteria.
- Can be effective on clean surfaces only.

NOTE

Using a SANITIZER on an unclean surface will not guarantee a clean and safe frozen dessert machine.

PROPER DAILY MAINTENANCE: THE ONLY WAY TO ASSURE FOOD SAFETY AND PRODUCT QUALITY

Proper daily maintenance can involve a wide variety of products and procedures. Overall, the products and procedures fall into three separate categories. (Please note that this is a brief overview intended for informational purposes only.)

1. **CLEANING** – This involves draining mix from the freezer barrel and rinsing the machine with water. Next, a cleaner is run through the machine. Then, the machine is disassembled and removable parts are taken to the sink for cleaning.

2. **MILKSTONE REMOVAL** – Since almost all cleaners do not have the ability to remove milkstone, the use of a delimer becomes necessary. Although this procedure may not be needed on a daily basis, it will usually follow the cleaning procedure. It requires letting a delimer solution soak in the machine for an extended period of time. Individual parts are also soaked in a deliming solution for an extended period of time (more about delimers in Additional Information).
3. **SANITIZING** – After the machine has been cleaned and contains no milkstone, the machine is reassembled. Then an FDA approved sanitizing solution is run through the machine to kill bacteria. The machine is then ready for food preparation.

As a recommended cleaner and sanitizer for your frozen dessert machine, Stera-Sheen has proven to be one of the best daily maintenance products for:

- **CLEANING** – Thorough removal of all solids including butterfat and milk fat.
- **MILKSTONE REMOVAL** – Complete removal of milkstone.
- **SANITIZING** – FDA approved no rinse sanitizer for food contact surfaces.

ADDITIONAL INFORMATION

THE USE OF DELIMERS

A delimer is a strong acid that has the ability to dissolve milkstone. This type of chemical may become necessary once high levels of milkstone have developed. While these products are very effective for removing HIGH levels of milkstone, they are not ideal for two reasons:

1. **PRODUCT SAFETY** – Strong acids are dangerous chemicals and handling them requires safety
2. **MACHINE DAMAGE** – Strong acids will attack metal and rubber causing premature wear of parts. The use of a delimer needs to be closely monitored to avoid damage to machine surfaces and parts.

With proper daily use of Stera-Sheen or its equivalent, there is no need for the use of a DELIMER.

DO NOT USE BLEACH

- **BLEACH HAS ABSOLUTELY NO CLEANING PROPERTIES.**
- **BLEACH IS CORROSIVE.** It can and will damage components of the machine causing premature wear and metal corrosion.

GENERAL PURPOSE CLEANERS

General purpose cleaners do not have the ability to remove milkstone. Milkstone will become a problem if not remedied with additional products and procedures.

THE USE OF CHLORINE TEST STRIPS

“Test strips” are used to determine concentrations of active chlorine in sanitizing solutions. To use the strips, tear off a small portion and submerge it into the sanitizing solution. Then, compare the color change to the color key on the side of the test strip dispenser to determine the approximate chlorine concentration.

The ideal concentration of chlorine needs to be 100 ppm (as stated by the FDA).

NOTE

Follow the directions on the container for proper concentration.

There are two main factors that contribute to falling chlorine concentrations in a sanitizing solution.

1. **PRODUCT USE** – As the chlorine in the solution is being used, chlorine concentrations fall.
2. **TIME** – As time passes, small amounts of chlorine “evaporate” from the solution. (That is why you can smell it.)

Sanitizing solutions should not be allowed to fall below 100 ppm chlorine. New solutions should be mixed as soon as old solutions become ineffective or if you are unsure of the concentration of chlorine.

3.13 PREVENTATIVE MAINTENANCE

A. DAILY

1. The exterior should be kept clean at all times to preserve the luster of the stainless steel. A mild alkaline cleaner is recommended. Use a soft cloth or sponge to apply the cleaner.

CAUTION

Do not use acidic cleansers, strong caustic compounds or abrasive materials to clean any part of the freezer exterior or plastic parts. Use of these types of cleaners will cause equipment damage.

B. WEEKLY

1. Check o-rings and rear seal for excessive wear and replace if necessary.
2. Remove the drip tray by gently lifting up to disengage from the support and pulling out. Clean behind the drip tray and front of the freezer with a soap solution.

C. MONTHLY

CAUTION

The freezer has an air cooled condenser and must have the proper air circulation. Maintain at least 3” of clearance at all louvered panels. Failure to clean the condenser filter on a regular basis may result in serious freezer damage and could void the freezer warranty.

1. Remove the condenser filter by lifting up and pulling bottom out and down. Then clean with warm soapy water. Rinse in clean water and shake dry, taking care not to damage the filter in any way.

D. SEMI-ANNUALLY

1. Check drive belt for proper tension. Push belt in with one finger, belt should deflect about 3/8”.
2. Lubricate condenser fan motor with S.A.E. 20 weight oil. Three to six drops is required.

CAUTION

Do not over-lubricate; resulting damage could cause motor failure.

3.14 EXTENDED STORAGE

Refer to the following steps for storage of the freezer over any long period of shutdown time:

- A. Turn the Power OFF-ON switch to the OFF position.
- B. Disconnect (unplug) from the electrical supply source.
- C. Clean thoroughly with a warm water detergent all parts that come in contact with the mix. Rinse in clean water and dry parts. Do not sanitize.

NOTE

Do not let the cleaning solution stand in the hopper or in the freezer barrel during the shutdown period.

- D. Remove, disassemble and clean the front door, mix inlet regulator and auger parts. Place the auger flights and the front auger support bushing in a plastic bag with a moist paper towel to prevent them from becoming brittle.
- E. In a water cooled freezer, disconnect water lines and drain water. With a flathead screwdriver, hold the water valve open and use compressed air to clear the lines of any remaining water.

SECTION 4 TROUBLESHOOTING

PROBLEM	POSSIBLE CAUSE	REMEDY
Freezer does not run.	<ol style="list-style-type: none"> 1. Power to freezer is off. 2. Fuse or circuit if blown or tripped. 3. Freeze-up (auger will not turn). 4. Front door not in place. 	<ol style="list-style-type: none"> 1. Supply power to freezer. 2. Replace or reset. 3. Turn Power OFF-ON switch to OFF for 15 minutes, then restart. 4. Assemble front door in place.
Freezer does not run, PUSH TO FREEZE light flashes in sequence of four.	<ol style="list-style-type: none"> 1. Freezer has been left in the CLEAN mode for more than 20 minutes. 2. CLEAN switch has been activated 3 times within 10 seconds. 	<ol style="list-style-type: none"> 1. Let light flash for 10 minutes, then place the Power OFF-ON switch to the OFF position to reset. 2. Leave Power OFF-ON switch in the ON position for 10 minutes, then place the switch to the OFF position to reset.
Freezer does not run, PUSH TO FREEZE light flashes in sequence	<ol style="list-style-type: none"> 1. No mix in hopper. 2. Mix inlet regulator not allowing mix to flow into barrel. 3. Sensor problem. 	<ol style="list-style-type: none"> 1. Fill hopper with mix 2. Remove mix inlet regulator, clean, sanitize, and replace. 3. Call distributor for service.
Freezer will not shut off.	<ol style="list-style-type: none"> 1. Temperature setting is too cold. 2. Push to freeze switch failure. 3. Spigot switch failure. 4. Reduced air flow. 5. Refrigeration problem. 	<ol style="list-style-type: none"> 1. Readjust. Call distributor for service. 2. Call distributor for service. 3. Call distributor for service. 4. Check for proper air flow through the condenser 5. Check system. Call distributor for service.
Product is too thin.	<ol style="list-style-type: none"> 1. Product is being dispensed when the PUSH TO FREEZE light is illuminated red. 2. No vent space for free flow of cooling air. 3. Air temperature entering condenser is above 100°F. 4. Condenser is dirty. 5. Temperature setting too warm. 6. Stabilizers in mix are broken down. 7. Auger is assembled wrong. 8. Reduced air flow. 9. Refrigeration problem. 	<ol style="list-style-type: none"> 1. Press the PUSH TO FREEZE push button. Wait until the green light illuminates before dispensing. 2. A minimum of 3" of vent space required. 3. Change location or direct hot air away from freezer. 4. Clean condenser. 5. Readjust. Call distributor for service. 6. Remove mix, clean, sanitize and restart with fresh mix. 7. Remove mix, clean, reassemble, sanitize and restart freezer. 8. Check for proper air flow through the condenser. 9. Check system. Call distributor for service.
Product is too thick.	<ol style="list-style-type: none"> 1. Small portions are being dispensed in a short time. 2. Temperature setting is too cold. 3. Line voltage fluctuating. 	<ol style="list-style-type: none"> 1. Allow freezer to sit idle for 5 minutes before dispensing. 2. Readjust. Call distributor for service. 3. Call distributor for service.
Product does not dispense.	<ol style="list-style-type: none"> 1. No mix in hopper. 2. Mix inlet regulator tube is plugged. 3. Special mix inlet regulator needed for mix being used. 4. Drive motor overload tripped. 5. Drive belt failure. 6. Freeze-up. (Auger will not turn.) 	<ol style="list-style-type: none"> 1. Fill hopper with mix. 2. Unplug, using small sanitized brush. 3. Order special mix inlet regulator. 4. Automatic reset. Wait 15 to 30 minutes. 5. Replace drive belt. 6. Turn Power OFF-ON switch to the OFF position for 15 minutes, then restart.

PROBLEM	POSSIBLE CAUSE	REMEDY
Drive belt slipping or squealing.	<ol style="list-style-type: none"> 1. Worn drive belt. 2. Freeze-up (Auger will not turn). 	<ol style="list-style-type: none"> 1. Call distributor for service. 2. Turn Power OFF-ON switch to the OFF position for 15 minutes, then restart.
Low overrun.	<ol style="list-style-type: none"> 1. Mix inlet regulator missing. 2. Mix inlet regulator o-ring missing 3. Mix inlet regulator air tube blocked. 4. Product breakdown. 	<ol style="list-style-type: none"> 1. Replace mix inlet regulator. 2. Replace mix inlet regulator o-ring. 3. Clean with sanitized brush. 4. Fill freezer with fresh product.
Front door leaks	<ol style="list-style-type: none"> 1. Front door knobs are loose. 2. Spigot parts are not lubricated. 3. Chipped or worn spigot o-rings. 4. O-rings or spigot installed wrong. 5. Inner spigot hole in front door nicked or scratched. 	<ol style="list-style-type: none"> 1. Tighten knobs. 2. Assemble & lube correctly. 3. Replace o-rings. 4. Remove spigot and check o-ring. 5. Replace front door.
Hopper will not maintain mix temperature below	<ol style="list-style-type: none"> 1. EPR valve needs adjustment. 2. Refrigeration problem. 3. Hopper cover not fitted properly. 	<ol style="list-style-type: none"> 1. Check system. Call distributor for service. 2. Check system. Call distributor for service. 3. Check hopper cover for proper fit.
Blender is not spinning	<ol style="list-style-type: none"> 1. Not plugged in or Blender switch not placed in ON position. 2. Blender shaft, agitator, and/or collar not tightened. 	<ol style="list-style-type: none"> 1. Plug in blender cord and turn Blender Power OFF-ON switch to the ON position. 2. Tighten components.

SECTION 5 REPLACEMENT PARTS

5.1 BRUSHES, DECALS AND LUBRICATION

Part Number	Description	Quantity
208135	Brush - 4" X 8" X 16" (Barrel)	1
208380	Brush - 1/4" X 3" X 14"	1
208401	Brush - 1" X 3" X 10"	1
324065	Decal - Water Inlet	-
324105	Decal - Caution Electrical Shock	-
324106	Decal - Caution Electrical Wiring Materials	-
324107	Decal - Caution Hazardous Moving Parts	-
324141	Decal - Caution Rotating Blades	-
324200	Decal - High Pressure Cut-Out	-
324208	Decal - Attention Refrigerant Leak Check	-
324393	Decal - Stoelting Swirl Logo (Drip Tray Support)	-
324509	Decal - Cleaning Instructions	-
324566	Decal - Wired According To	-
324584	Decal - Adequate Ventilation 3"	1
324593	Decal - Power	1
324686	Decal - Danger Automatic Start	2
324803	Decal - Domed Stoelting Logo (Large) (Header Panel)	1
324804	Decal - Domed Stoelting Swirl (Header Panel)	1
324835	Decal - Blender Power On / Off	1
324837	Decal - Caution Blender	1
324877	Decal - Sonic Logo (Header Panel)	-
508048	Lubricant - Spline (2 oz Squeeze Tube)	1
508135	Petrol Gel - 4 oz Tube	1
1177990	Caster Kit - 4" (Set Of 4)	1
1183954	O-Ring Kit (Ser. #0 - #28937)	-
2177917	Brush Kit	-

5.2 AUGER SHAFTS AND FRONT DOOR PARTS

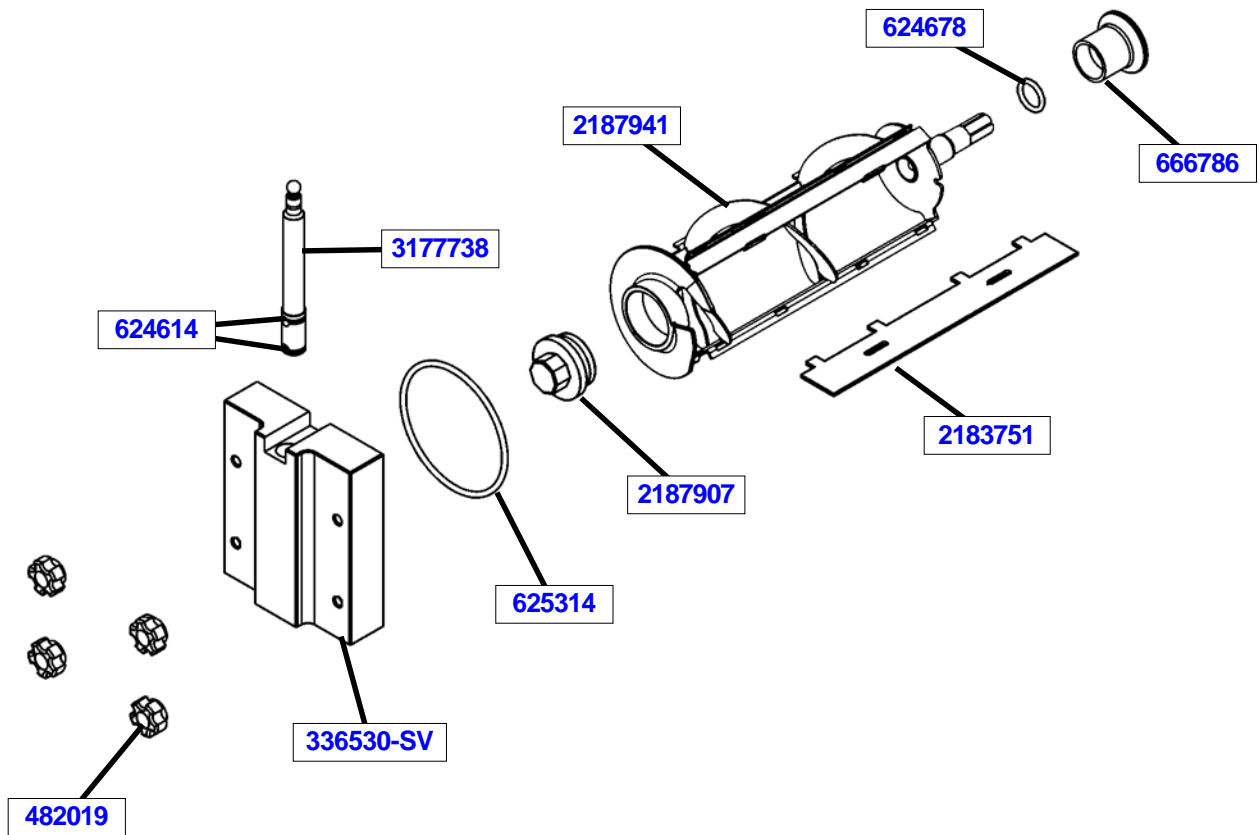

Part Number	Description	Quantity
149002	Bushing - Front Auger Support (Ser. #0 - #28937)	-
162155	Scraper Blade (Ser. #0 - #28937)	-
482019	Knob - Front Door (Black)	4
336530-SV	Door w/Pins	1
624614-5	O-Ring - Spigot - Black (5 Pack)	2
624678-5	O-Ring - Rear Seal - Black (5 Pack)	1
625314	O-Ring - Front Door - Black	1
666786	Seal - Rear Auger - Black	1
2183751	Blade - Scraper (Ser. #28938 Plus)	1
2187907	Bushing - Front Auger Support (Ser. #28938 Plus)	1
2187941	Auger Shaft (Ser. #28938 Plus)	1
3177738	Spigot Body	1

5.3 BLENDER PARTS AND DRIP TRAY

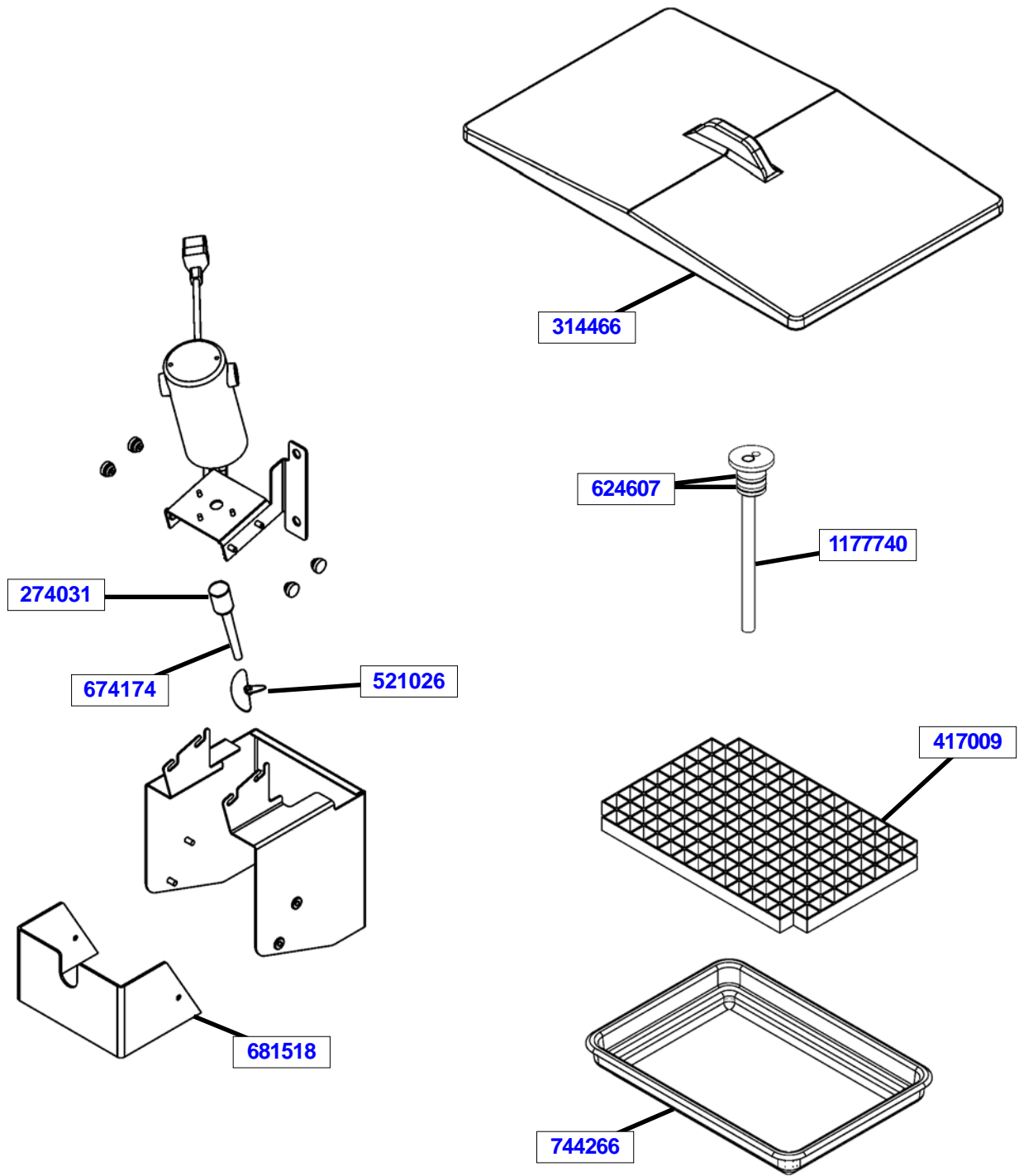

Part Number	Description	Quantity
314466	Cover - Hopper	1
417009	Grid - Drip Tray (White Honeycomb)	1
521026	Blender Agitator	1
624607-5	O-Ring - Mix Inlet - Black (5 Pack)	2
674174	Blender Shaft	1
681518	Shield - Plastic Swing	1
744266	Tray - Drip (White)	1
1177740	Mix Inlet Assembly	1
3177732	Tray - Drain	1



WARRANTY SOFT SERVE / SHAKE FREEZERS

1. Scope:

Stoelting, LLC warrants to the first user (the "Buyer") that the freezer cylinders, hoppers, compressors, drive motors, speed reducers, augers and auger flights of Stoelting soft serve / shake freezers will be free from defects in materials and workmanship under normal use and proper maintenance appearing within five (5) years, and that all other components of such equipment manufactured by Stoelting will be free from defects in material and workmanship under normal use and proper maintenance appearing within twelve (12) months after the date that such equipment is originally installed.

2. Disclaimer of Other Warranties:

THIS WARRANTY IS EXCLUSIVE; AND STOELTING HEREBY DISCLAIMS ANY IMPLIED WARRANTY OF MERCHANTABILITY OR FITNESS FOR PARTICULAR PURPOSE.

3. Remedies:

Stoelting's sole obligations, and Buyer's sole remedies, for any breach of this warranty shall be the repair or (at Stoelting's option) replacement of the affected component at Stoelting's plant in Kiel, Wisconsin, or (again, at Stoelting's option) refund of the purchase price of the affected equipment, and, during the first twelve (12) months of the warranty period, deinstallation/reinstallation of the affected component from/into the equipment. Those obligations/remedies are subject to the conditions that Buyer (a) signs and returns to Stoelting, upon installation, the Checklist/Warranty Registration Card for the affected equipment, (b) gives Stoelting prompt written notice of any claimed breach of warranty within the applicable warranty period, and (c) delivers the affected equipment to Stoelting or its designated service location, in its original packaging/crating, also within that period. Buyer shall bear the cost and risk of shipping to and from Stoelting's plant or designated service location.

4. Exclusions and Limitations:

This warranty does not extend to parts, sometimes called "wear parts", which are generally expected to deteriorate and to require replacement as equipment is used, including as examples but not intended to be limited to o-rings, auger seals, auger support bushings and drive belts. All such parts are sold

AS IS.

Further, Stoelting shall not be responsible to provide any remedy under this warranty with respect to any component that fails by reason of negligence, abnormal use, misuse or abuse, use with parts or equipment not manufactured or supplied by Stoelting, or damage in transit.

THE REMEDIES SET FORTH IN THIS WARRANTY SHALL BE THE SOLE LIABILITY STOELTING AND THE EXCLUSIVE REMEDY OF BUYER WITH RESPECT TO EQUIPMENT SUPPLIED BY STOELTING; AND IN NO EVENT SHALL STOELTING BE LIABLE FOR ANY INCIDENTAL OR CONSEQUENTIAL DAMAGES, WHETHER FOR BREACH OF WARRANTY OR OTHER CONTRACT BREACH, NEGLIGENCE OR OTHER TORT, OR ON ANY STRICT LIABILITY THEORY.

January 30, 2003
721-013, Rev. 0