



**Model SU444 / U444A**  
**SERVICE MANUAL**

Manual No. [513640](#)

Rev.1



This manual provides basic information about the machine. Instructions and suggestions are given covering its operation and care.

The illustrations and specifications are not binding in detail. We reserve the right to make changes to the machine without notice, and without incurring any obligation to modify or provide new parts for machines built prior to date of change.

**DO NOT ATTEMPT** to operate the machine until instructions and safety precautions in this manual are read completely and are thoroughly understood. If problems develop or questions arise in connection with installation, operation, or servicing of the machine, contact Stoelting.



[stoeltingfoodservice.com](http://stoeltingfoodservice.com)

Stoelting Foodservice Equipment  
502 Highway 67  
Kiel, WI 53042-1600  
U.S.A.

Main Tel: 800.558.5807  
Fax: 920.894.7029

Customer Service: 888.429.5920  
Fax: 800.545.0662  
Email: [foodservice@stoelting.com](mailto:foodservice@stoelting.com)

© 2014 PW Stoelting, LLC

---

## ***A Few Words About Safety***

### **Safety Information**

**Read and understand the entire manual before operating or maintaining Stoelting equipment.**

This manual provides the operator with information for the safe operation and maintenance of Stoelting equipment. As with any machine, there are hazards associated with their operation. For this reason safety is emphasized throughout the manual. To highlight specific safety information, the following safety definitions are provided to assist the reader.

The purpose of safety symbols is to attract your attention to possible dangers. The safety symbols, and their explanations, deserve your careful attention and understanding. The safety warnings do not by themselves eliminate any danger. The instructions or warnings they give are not substitutes for proper accident prevention measures.

If you need to replace a part, use genuine Stoelting parts with the correct part number or an equivalent part. We strongly recommend that you do not use replacement parts of inferior quality.



### **Safety Alert Symbol:**

**This symbol** Indicates danger, warning or caution. Attention is required in order to avoid serious personal injury. The message that follows the symbol contains important information about safety.

### **Signal Word:**

Signal words are distinctive words used throughout this manual that alert the reader to the existence and relative degree of a hazard.



The signal word “WARNING” indicates a potentially hazardous situation, which, if not avoided, may result in death or serious injury and equipment/property damage.



The signal word “CAUTION” indicates a potentially hazardous situation, which, if not avoided, may result in minor or moderate injury and equipment/property damage.

### **CAUTION**

The signal word “CAUTION” not preceded by the safety alert symbol indicates a potentially hazardous situation, which, if not avoided, may result in equipment/property damage.

### **NOTE (or NOTICE)**

The signal word “NOTICE” indicates information or procedures that relate directly or indirectly to the safety of personnel or equipment/property.

# TABLE OF CONTENTS

<b>Section</b>	<b>Description</b>	<b>Page</b>
<b>1</b>	<b>Introduction</b>	
1.1	Description.....	1
1.2	Specifications .....	2
1.3	Right Side Control Operation.....	3
A.	Initial Status.....	3
B.	Serve Mode.....	3
C.	Standby Mode .....	3
D.	Sleep 1 Mode.....	4
E.	Sleep 2 Mode .....	4
F.	IntelliTec Restart.....	4
G.	Sleep 3 Mode .....	4
H.	Clean Mode.....	5
1.4	Mix Level Indicators.....	5
1.5	Storage Refrigeration .....	5
1.6	Operation During Sensor Failure.....	5
A.	Serve and Standby Mode.....	5
B.	Cabinet Refrigeration .....	5
1.7	Motor Profile Cutout Compensation .....	5
1.8	Left Side Control Operation .....	6
A.	Initial Status.....	6
B.	Standby Mode .....	6
C.	Serve Mode.....	6
D.	Clean.....	6
<b>2</b>	<b>Installation Instructions</b>	
2.1	Safety Precautions .....	9
2.2	Shipment and Transit.....	9
2.3	Machine Installation.....	9
2.4	Installing Wiring .....	9
2.5	Check Compressor for Proper Power (3 Phase Only).....	10
2.6	Check Blender Rotation.....	10
2.7	Mix Pump.....	10
A.	Mix Pump Hose Installation.....	10
B.	Mix Pickup Hose Installation .....	11
C.	Mix Low Level Indicator Adjustment.....	12

<b>Section</b>	<b>Description</b>	<b>Page</b>
<b>3</b>	<b>Initial Set-Up and Operation</b>	
3.1	Operator's Safety Precautions.....	13
3.2	Operating Controls and Indicators.....	13
3.3	Important Information Regarding Cleaning and Sanitizing.....	14
3.4	Disassembly of Left Side.....	16
3.5	Disassembly of Right Side.....	17
3.6	Cleaning Disassembled Parts.....	18
3.7	Sanitizing Parts.....	18
3.8	Cleaning the Machine.....	18
3.9	Assembling the Left Side.....	18
3.10	Assembling the Right Side.....	19
3.11	Sanitizing.....	20
3.12	Initial Freeze Down and Operation.....	21
3.13	Normal Freeze Down And Operation.....	22
3.14	Mix Information.....	23
3.15	Operation of Mix Pump.....	23
3.16	Mix Pump Cleaning.....	23
3.17	Disassembly and Inspection of Removable Parts.....	24
<b>4</b>	<b>Maintenance and Adjustments</b>	
4.1	Machine Adjustment.....	25
4.2	Product Temperature Adjustment (Left Side).....	25
4.3	Product Consistency Adjustment (Right Side).....	25
4.4	Locking the Control Panel (Right Side).....	25
4.5	Obtaining Readings and Modifying Settings (Service Personnel Only) (Right Side).....	25
4.6	Readings (Service Personnel Only) (Right Side).....	26
4.7	Adjustments (Service Personnel Only) (Right Side).....	27
4.8	Other Settings (Service Personnel Only) (Right Side).....	28
4.9	Overrun Adjustment.....	28
4.10	Mix Pump Hose Reposition.....	29
4.11	Mix Pump Hose Replacement.....	30
4.12	Cab Temperature Adjustment.....	30
4.13	Drive Belt Tension Adjustment.....	31
4.14	Condenser Cleaning (Air- Cooled Machines).....	31
4.15	Preventative Maintenance.....	31
4.16	Extended Storage.....	32

<b>Section</b>	<b>Description</b>	<b>Page</b>
<b>5</b>	<b>Refrigeration System</b>	
5.1	Refrigeration System .....	33
5.2	Refrigerant Recovery And Evacuation.....	33
A.	Refrigerant Recovery .....	34
B.	Evacuating the Refrigeration System.....	34
5.3	Refrigerant Charging .....	34
5.4	Compressor .....	35
5.5	Condenser .....	36
5.6	Evaporator .....	36
5.7	Valves .....	37
A.	Thermostatic Expansion Valve (TXV) .....	37
B.	Check Valve .....	38
C.	High Pressure Cutout.....	38
D.	Water Valve (Water Cooled Models Only).....	38
5.8	Solenoid.....	39
5.9	Filter Drier .....	40
5.10	Capillary Tube.....	41
5.11	Cab Unit.....	41
<b>6</b>	<b>Electrical and Mechanical Control Systems</b>	
6.1	Controls .....	43
A.	IntelliTec Control.....	43
B.	Challenger Control .....	43
6.2	Contactors .....	43
6.3	Drive Motor .....	44
6.4	Capacitors .....	45
6.5	Gearbox.....	45
6.6	Condenser Fan Motor (Air- Cooled Only).....	46
6.7	Cab Condenser Fan Motor .....	47
6.8	Switches .....	47
A.	Spigot Switch .....	47
B.	Blender Activation Switch (Shake).....	48
C.	Pump Pressure Switch.....	48
D.	Cab Door Magnetic Reed Switch .....	48
6.9	Temperature Control Sensor .....	49

<b>Section</b>	<b>Description</b>	<b>Page</b>
<b>7</b>	<b>Troubleshooting</b>	
7.1	Error Codes (Right Side) .....	51
7.2	Troubleshooting - Error Codes (Right Side) .....	51
7.3	Troubleshooting - Freezer .....	53
7.4	Troubleshooting - Mix Pump.....	54
<b>8</b>	<b>Replacement Parts</b>	
8.1	Brushes, Decals and Lubrication.....	57
8.2	Accessories .....	58
8.3	Kits.....	58
8.4	Panels and Screws.....	58
8.5	Left Side Auger Shaft and Front Door Parts .....	59
8.6	Right Side Auger Shaft and Front Door Parts.....	60
8.7	Blender Parts and Drip Tray .....	61
8.8	Machine Front.....	62
8.9	Spigot Assemblies .....	63
8.10	Cab Interior.....	64
8.11	Cab Tubing .....	65
8.12	Pump Parts.....	66
8.13	Header Panel - Electrical.....	68
8.14	Right Side .....	69
8.15	Rear.....	70
8.16	Left Side and Cabinet Refrigeration System .....	72
8.17	Wiring Diagrams.....	73

# SECTION 1 DESCRIPTION AND SPECIFICATIONS

## 1.1 DESCRIPTION

The Stoelting SU444 and U444A floor model machines are pressure fed. They are equipped with fully automatic controls to provide a uniform product. The SU444 and U444A are designed to dispense soft serve product from the left side and shake product from the right side. The SU444 has a blender attached to the front door of the shake side.

This manual is designed to assist qualified service personnel and operators with installation, operation and maintenance of the SU444 and U444A.



Figure 1-1 Model SU444 Machine

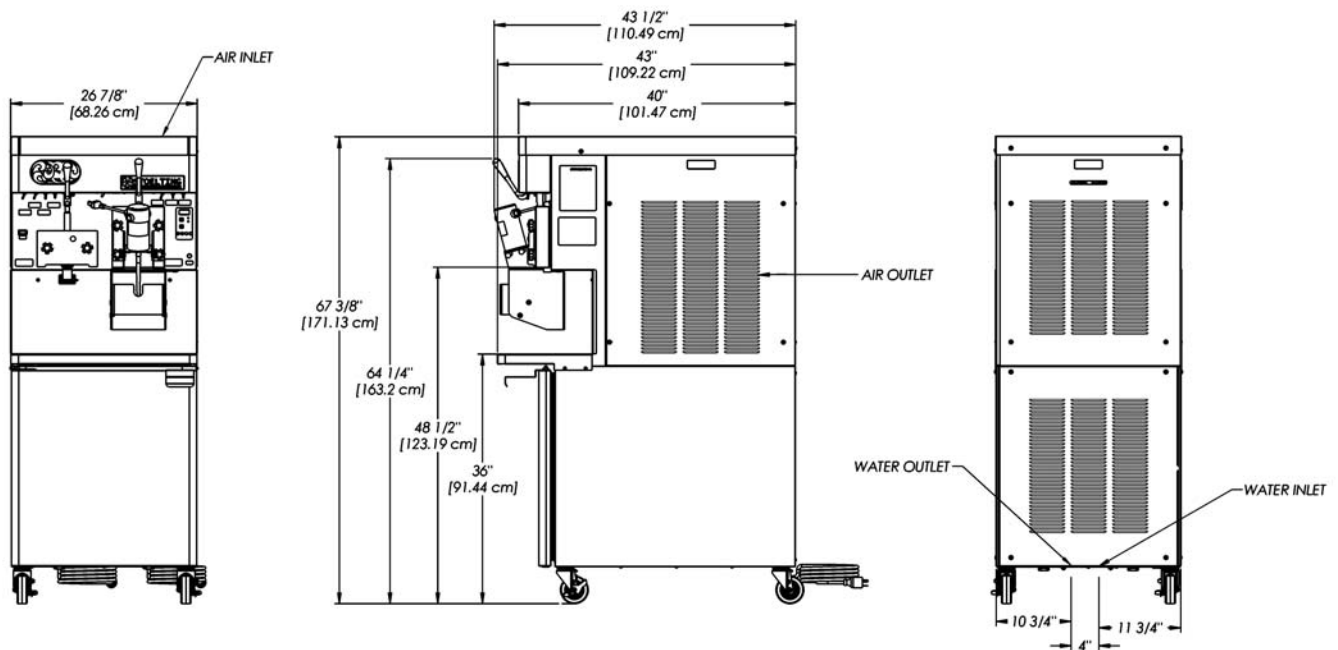

Figure 1-2 Dimensions

## 1.2 SPECIFICATIONS

	SU444 Water Cooled				SU444 Air Cooled				
Dimensions	Machine		with crate		Machine		with crate		
	width	26-7/8" (68,3 cm)	34" (86,4 cm)	26-7/8" (68,3 cm)	34" (86,4 cm)	26-7/8" (68,3 cm)	34" (86,4 cm)	26-7/8" (68,3 cm)	34" (86,4 cm)
	height	67-3/8" (171,1 cm)	78" (198,1 cm)	67-3/8" (171,1 cm)	78" (198,1 cm)	67-3/8" (171,1 cm)	78" (198,1 cm)	67-3/8" (171,1 cm)	78" (198,1 cm)
depth	40" (101,6 cm)	48" (121,9 cm)	40" (101,6 cm)	48" (121,9 cm)	40" (101,6 cm)	48" (121,9 cm)	40" (101,6 cm)	48" (121,9 cm)	
Weight	760 lbs (344,7 kg)	908 lbs (411,8 kg)	760 lbs (344,7 kg)	908 lbs (411,8 kg)	760 lbs (344,7 kg)	908 lbs (411,8 kg)	760 lbs (344,7 kg)	908 lbs (411,8 kg)	
Electrical	1 PH		3 PH		1 PH		3 PH		
	left	right	left	right	left	right	left	right	
	minimum circuit ampacity	31A	26A	19A	18A	32A	26A	20A	18A
maximum overcurrent protection device	50A	40A	30A	25A	50A	40A	30A	25A	
Compressor	Soft Serve - 19,000 Btu/hr Scroll™ Compressor (R-404A) Shake - 15,000 Btu/hr Scroll™ Compressor (R-404A) Cabinet - 1,300 Btu/hr Compressor (R-134a)								
Drive Motor	Soft Serve - 2 hp, Shake - 3/4 hp								
Cooling	Water cooled units require 1/2" N.P.T. water and drain fittings. Maximum water pressure of 130 psi. Minimum water flow rate of 3 GPM. Ideal EWT of 50°-70°F. The machine requires 6" (15,2 cm) air space on all sides for the cabinet refrigeration system.				Air cooled units require 6" (15,2 cm) air space on both sides and back.				
Hopper Volume	Two - 8 gallon (30,28 liters)								
Freezing Cylinder Volume	Soft Serve - 1.33 gallon (5,4 liters) Shake - 2.1 gallon (7,95 liters)								

Menu	Display	Value
<b>Basic</b>	CutOut	* amps
	Cut In T	28.5 °F
	Cycles	20 count
	Stir On	15 seconds
	Stir Off	300 seconds
<b>Advanced</b>	On Time	28 seconds
	Off Time	450 seconds
	Stb Time	120 minutes
	SI1DrvOn	120 seconds
	SI1DrOff	180 seconds
	SI2CutIn	37 °F
	SI2CtOut	31 °F
DftOffTm	900 seconds	
<b>Storage</b>	Refriger	Cabinet
	CabCutIn	38 °F
	CabCtOut	34 °F
	Cab Off	13 minutes
	Cab On	130 seconds

\* CutOut value needs to be adjusted to product requirements

	SU444
<b>Refrigerant</b>	R-404A
<b>Charge</b>	Left Side - 46 oz Right Side - 46 oz
<b>Suction Pressure</b>	Soft Serve - 23-24 psig Shake - 28-30 psig
<b>Discharge Pressure</b> at 80°F Ambient	Soft Serve - 235-240 psig Shake - 235-240 psig
	<b>Cabinet</b>
<b>Refrigerant</b>	R-134A
<b>Charge</b>	8 oz
<b>Cab Suction Pressure</b>	18 psig

### 1.3 RIGHT SIDE CONTROL OPERATION

Following are details of the operational modes on the right side of the SU444 and U444A.

#### NOTE:

*The preset amounts, times, and temperatures listed below are references to actual settings on the IntelliTec control. Refer to Table 1-1 on page 6 for details on each setting.*

#### A. INITIAL STATUS

When the Main Freezer Power and Freezing Cylinder switches are placed in the ON position, the machine will start in the "Sleep 1 Mode". The display will read "Sleep 1 Mode". The control will eventually move into the "Sleep 2" mode if the PUSH TO FREEZE button is not pressed. When the PUSH TO FREEZE button is pressed the control will move to the "Serve Mode".

#### B. SERVE MODE

When the PUSH TO FREEZE button is pressed or a spigot handle is pulled, the "Serve Mode" begins. The drive motor starts, and after a 3 second delay, the compressor starts. The display reads "FREEZING" on the top line and a bar on the bottom line increases with product consistency. A toroid on the IntelliTec control senses increasing drive motor amperage as the product comes to consistency in the freezing cylinder. When the control senses the product is at 75% of consistency, the display will read "SERVE", the amber LED will go out, and the green LED will blink. At this time, product can be served from the machine. The drive motor and compressor will continue to run until the toroid reads a preset value (CutOut amps). When the toroid reads the CutOut amps on the drive motor, the compressor turns off. After a 3 second delay, the drive motor turns off. The product in the freezing cylinder is now at serving temperature and consistency and the green LED will remain lit.

After product is at consistency, the IntelliTec control continuously monitors refrigerant temperature through a thermistor mounted on the side of the freezing cylinder. When the temperature increases to a preset amount (Cut In T), a 3-second drive motor pre-stir analyzes product consistency. The pre-stir check is also performed each time the spigot handle is opened. This check prevents over-freezing of product, especially during frequent, small volume draws. If product requires a freezing cycle, the control will start the cycle.

During the "Serve Mode", a stir cycle starts. This cycle is independent of the freezing cycle and is based on preset times (Stir On and Stir Off). The stir cycle prevents product separation. If a freezing cycle is initiated, the timer is reset.

In addition to the "Serve Mode" freezing cycle, there is a freezing cycle based on a preset time (DftOffTime). If this time is attained without a freezing cycle, the control will automatically start a freezing cycle. If a freezing cycle is initiated, the timer is reset.

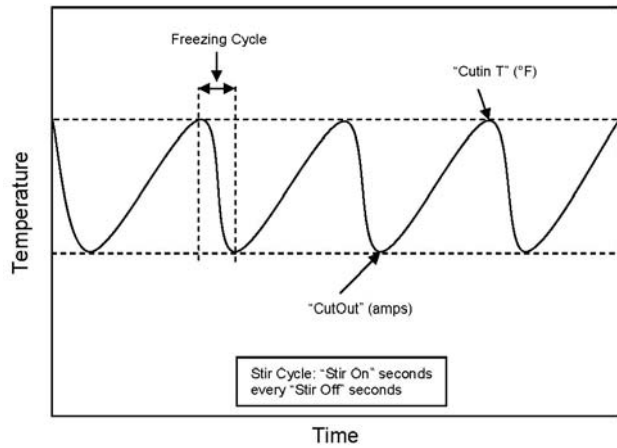

Figure 1-3 Serve Mode

The machine will remain in "Serve Mode" until the cycle count setting is attained. The cycle count is the number of active freezing cycles and is based on a preset value (Cycles). Once the cycle count has been reached without user interruption, the control will move into the "Standby Mode".

If the PUSH TO FREEZE button is pressed or a spigot handle is pulled, the cycle count is reset and the control will move to the beginning of the "Serve Mode". Refer to Figure 1-3 for a graphical representation of the "Serve Mode".

#### C. STANDBY MODE

If product has not been drawn from the spigot and the preset number of active freezing cycles is met, the control moves into the "Standby Mode". In "Standby Mode", the freezing cycle is based on preset timers (On Time and Off Time), and prevents ice crystals from building up in the product. Because the product remains partially frozen, it can quickly return to servable consistency when the PUSH TO FREEZE button is pressed.

During "Standby Mode", the stir cycle runs. This cycle is based on preset, timed intervals (Stir On and Stir Off) and prevents product separation.

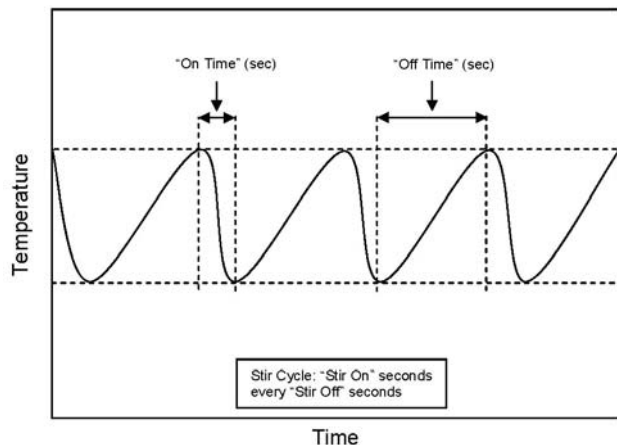

Figure 1-4 Standby Mode

The “Standby Mode” maintains product quality during slow times, while minimizing reactivation time. This mode lasts for a preset time (Stb Time). Once this time has been reached without user interruption, the control moves into the “Sleep 1 Mode”. Refer to Figure 1-4 for a graphical representation of the “Standby Mode”.

If a spigot is opened or the PUSH TO FREEZE button is pressed, the control will move to “Serve Mode”. Product in the front of the freezing cylinders may or may not be at consistency. The state of the product is dependant on a number of variables but will come to consistency quickly.

#### D. SLEEP 1 MODE

After the “Standby Mode” time has expired without user interruption, the control will move into the “Sleep 1 Mode”. During the “Sleep 1 Mode”, the stir cycle is handled by preset timers (SI1DrvOn and SI1DrOff), and allows product to melt to a liquid state by using agitation cycles without any flow of refrigerant. Although the product temperature never increases above 41°F, the product thaws rapidly which minimizes product breakdown. The control will stay in the “Sleep 1 Mode” until sensing a preset temperature (SI2CutIn). When this temperature has been reached without user interruption, the control will move to the “Sleep 2 Mode”. Refer to Figure 1-5 for a graphical representation of the “Sleep 1 Mode”.

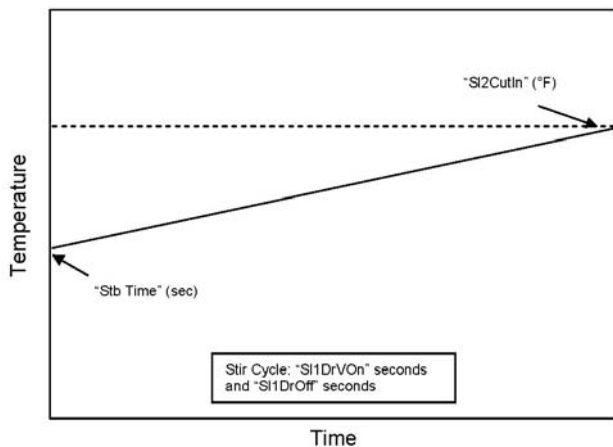
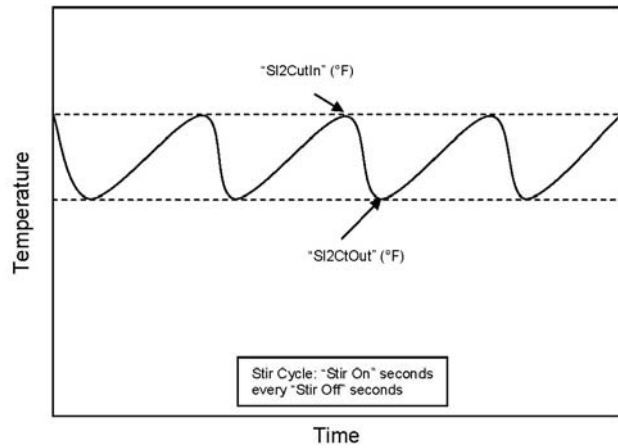

**Figure 1-5 Sleep 1 Mode**

If a spigot is opened or the PUSH TO FREEZE button is pressed, the control will move to “Serve Mode”. If the spigot is opened in “Sleep 1 Mode”, the product will not be at consistency. The operator must wait until the first “Serve Mode” freezing cycle has completed to serve product.

#### E. SLEEP 2 MODE

The “Sleep 2 Mode” maintains the freezing cylinder temperature between two preset values (SI2CutIn and SI2CtOut). During the “Sleep 2 Mode”, the stir cycle runs. This cycle is based on preset, timed intervals (Stir On and Stir Off) and prevents product separation. The “Sleep 2 Mode” is often referred to by customers as the “night mode” and the machine will stay in this mode until a spigot is opened or the PUSH TO FREEZE button is



**Figure 1-6 Sleep 2 Mode**

pressed. When this occurs, the control will move to “Serve Mode”. If the spigot is opened at this time, the product will be liquid. The operator must wait until the first “Serve Mode” freezing cycle has completed to serve product. Refer to Figure 1-6 for a graphical representation of the “Sleep 2 Mode”.

#### F. INTELLITEC RESTART

If a hard error occurs (refer the hard error list below), the IntelliTec control will wait 5 minutes then attempt to clear the error by restarting itself. The control will count each restart attempt. The restart count will reset if the PUSH TO FREEZE button is pressed, the spigot is pulled, or the Freezing Cylinder OFF/ON switch is placed in the OFF position.

The following are considered hard errors:

##### ERROR CODE MALFUNCTION

- 2 High Torque
- 3 Run Time
- 4 Clean
- 7 Drive Motor
- 9 High Pressure Cutout

When a restart occurs, the second line of the display will read “Restart” and the backlight will blink. This will occur regardless of the system mode.

#### G. SLEEP 3 MODE

If a high torque, run time, or drive motor error condition occurs on the third restart attempt, the control will move to the “Sleep 3 Mode”.

In “Sleep 3 Mode” freezing cylinder refrigeration will run for 4 seconds every 10 minutes. This ensures the product temperature never increases above 41°F. The stir cycle and the auger do not run during “Sleep 3 Mode”.

The control will exit “Sleep 3 Mode” if the PUSH TO FREEZE button is pressed, the spigot is pulled, or the Freezing Cylinder OFF/ON switch is placed in the OFF position.

## H. CLEAN MODE

When the CLEAN button is pressed, freezing cylinder refrigeration stops, the drive motor starts and will run for 20 minutes, and a 5 minute countdown timer is displayed. After the time has elapsed, an optional audible alarm will sound if this accessory has been installed. The audible alarm is a reminder for the operator to end the “Clean Mode” when cleaning is completed.

If the machine is kept in “Clean Mode” for more than 20 minutes, the auger drive motor stops and an error code (E4) is displayed on the display panel. The error code prevents damage to the machine that could occur during an extended clean mode (Refer to Section 8 - Troubleshooting for details). To clear this error, place the Freezing Cylinder Off/On switch in the OFF position and back in the ON position. If the machine is still being cleaned, pushing the CLEAN button will reset the timer and restart the “Clean Mode”.

## 1.4 MIX LEVEL INDICATORS

The cabinet is equipped with a capacitive sensor to monitor mix level. When the mix level drops below the sensor limit, the lower line of the display will read “Low Mix” and the display will flash. To clear the “Low Mix” error, add mix to the cabinet’s mix container.

## 1.5 STORAGE REFRIGERATION

The IntelliTec control is programmed to handle refrigeration of the cabinet independently from the freezing cylinder. The control maintains cabinet temperature between two preset values (CabCutIn and CabCtOut). The cabinet will operate automatically unless one of the following conditions are met:

If the Main Power switch is in the OFF position the Cab Off light on the front of the machine will flash.

If the cabinet door is opened during a refrigeration cycle, the evaporator fan will continue to run but the refrigeration cycle will be interrupted to prevent the evaporator coils from icing up.

If there is a High Pressure Cutout Error (E9) all the refrigeration stops.

### NOTE

*If the temperature in the cabinet stays above 50°F for more than two hours, the machine will go into Sleep Mode and a clean message will be shown on the display.*

## 1.6 OPERATION DURING SENSOR FAILURE

The IntelliTec control is designed to allow the machine to continue to function if a temperature sensor failure occurs. If a sensor fails, the display will show the error and the control will run the machine on timers for the freezing cycle or cabinet refrigeration. This allows the operator to continue to serve product from the machine until proper servicing can be completed.

## A. SERVE AND STANDBY MODE

In the event of a temperature sensor failure on a freezing cylinder, the IntelliTec control will function in two modes, “Serve Mode” and “Standby Mode”. When the product is at consistency in “Serve Mode”, the IntelliTec control uses a timer instead of the sensor and will not start another freezing cycle until a preset value (DftOffTm) is met.

The control will monitor product after it is at consistency, activating the stir cycle and counting the number of cycles. When the cycle count is reached, the control will move to “Standby Mode”.

The “Standby Mode” is the same as in normal operation with the exception of when the preset time (Stb Time) is met, the control moves back into the “Serve Mode”. Refer to Figure 1-7 for details.

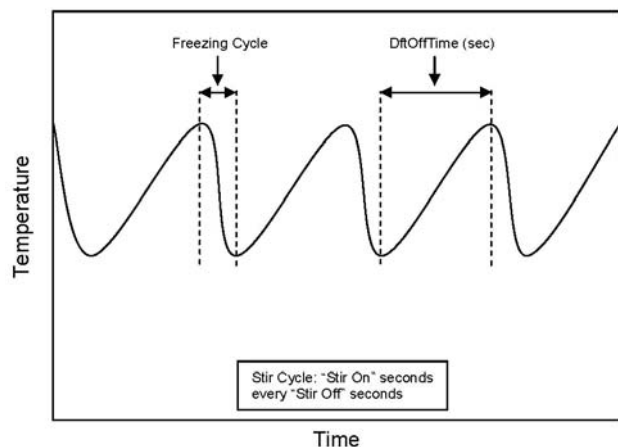

Figure 1-7 Serve Mode (Sensor Failure)

## B. CABINET REFRIGERATION

In the event of a temperature sensor failure in the cabinet, the cabinet refrigeration cycle is managed by preset times (Cab On and Cab Off). This refrigeration cycle is independent of the freezing cylinder refrigeration and the cycle restarts if the cabinet door is opened.

## 1.7 MOTOR PROFILE CUTOUT COMPENSATION

The IntelliTec control is programmed to automatically function at a range of supply voltages. This feature provides the advantage of having product maintained at a specific temperature and consistency irrespective of the supply voltage. A motor profile curve is programmed on the IntelliTec control and provides a relationship between the supply voltage and drive motor cutout amperage. Depending on the supply voltage, the control varies cutout amperage according to the motor profile. This feature is automatic and does not need any configuring.

## IntelliTec Control Setting Specifications

Basic Menu	DISPLAY	Value	MODE	DEFINITION
	CutOut	*	Serve	Amp draw setting for cut out
	Cut In T	28.5°F	Serve	Temperature setting for cut in
	Cycles	20	Serve	Freezing cycles before going into Standby Mode
	Stir On	15 sec	Serve	Stir-only on time
	Stir Off	300 sec	Serve	Stir-only off time

Advanced Menu	DISPLAY	Value	MODE	DEFINITION
	On Time	28 sec	Standby	Freezing cycle “on” time (runs on timers only)
	Off Time	450 sec	Standby	Freezing cycle “off” time
	Stb Time	120 sec	Standby	Total time in mode
	SI1DrvOn	120 sec	Sleep 1	Drive motor “on” timer
	SI1DrOff	180 sec	Sleep 1	Drive motor “off” timer
	SI2CutIn	37°F	Sleep 2	Cut in temperature
	SI2CtOut	31°F	Sleep 2	Cut out temperature
DftOffTm	900 sec	No Sensor	Default “off” time. Used in case of sensor failure	

Storage Menu	DISPLAY	Value	MODE	DEFINITION
	Refriger	Cabinet	All	Set to None, 1 Hopper, 2 Hopper, or Cabinet
	CabCutIn	38°F	All	Refrigerated cab cut in temperature
	CabCtOut	34°F	All	Refrigerated cab cut out temperature
	Cab Off	13 min	No Sensor	Default “off” time. Used in case of sensor failure
Cab On	130 sec	No Sensor	Default “on” time. Used in case of sensor failure	

\* The CutOut value needs to be adjusted to product requirements. Refer to the 2187695 - Specification Sheet for SU444 Control located in the plastic pouch behind the header panel.

**Table 1-1 IntelliTec Control Settings**

## 1.8 LEFT SIDE CONTROL OPERATION

The soft serve side is run by a temperature control. Following are details of the operational modes on the left side of the SU444 and U444A.

### A. INITIAL STATUS

When the Clean/Off/Serve switch is in the Off position and the freezer is powered, the red LED on the control board will be lit. The red LED will remain lit whenever the board is powered.

The refrigeration and drive motor will not cycle in the Off position.

### B. STANDBY MODE

When Clean/Off/Serve switch is placed in the Serve position and the Standby/Serve switch is in the Standby position, the machine is in Standby mode.

During Standby mode, the HI relay monitors the resistance of the freezing cylinder sensor. When the sensor resistance is below the HI relay cutin, a freezing cycle begins. On the control board, the yellow LED will light. The drive motor starts, and after a 3 second delay, the compressor starts. When the temperature in the freezing cylinder reaches the HI relay cutout, the compressor turns off. After a 3 second delay, the drive motor turns off. The yellow LED will turn off.

During standby, product in the freezing cylinder will be safely kept below 41°F. The product is not kept in a servable state.

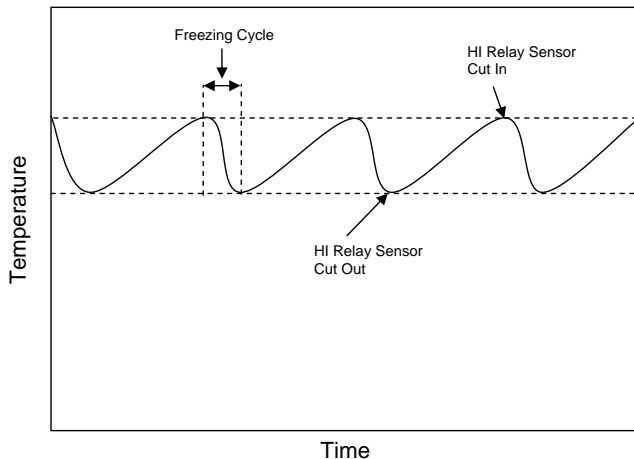

Figure 1-8 Standby Mode

### C. SERVE MODE

When Clean/Off/Serve switch is in the Serve position and the Standby/Serve switch is placed in the Serve position, the machine is in Serve mode.

During Serve mode, the LO relay monitors the resistance of the freezing cylinder sensor. When the sensor resistance is below the LO relay cutin, a freezing cycle begins. On the control board, the green LED will light. The drive motor starts, and after a 3 second delay, the compressor starts.

## NOTE

*If the sensor resistance is below the HI relay cutout, the yellow LED will also light. The yellow LED will remain lit until the sensor resistance reaches the HI relay cutout. The freezing cycle will continue until the LO relay cutout is met.*

When the temperature in the freezing cylinder reaches the LO relay cutout, the compressor turns off. After a 3 second delay, the drive motor turns off and the green LED turns off.

If the freezing switch is placed in the MAXIMUM position, the machine is forced to run 30 seconds after the LO relay cutout is satisfied.

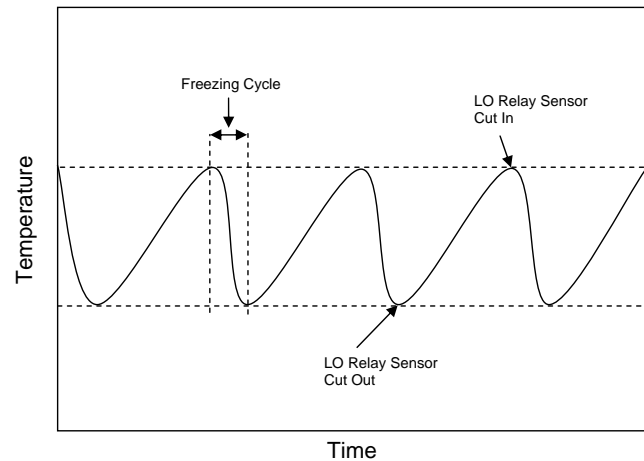

Figure 1-9 Serve Mode

### D. CLEAN

When the Clean/Off/Serve switch is placed in the Clean position, refrigeration stops, the drive motor starts and will run for 20 minutes.

If the machine is left in Clean mode for 20 minutes, the drive motor will stop to prevent damage to the machine.



## SECTION 2 INSTALLATION INSTRUCTIONS

### 2.1 SAFETY PRECAUTIONS

Do not attempt to operate the machine until the safety precautions and operating instructions in this manual are read completely and are thoroughly understood.

Take notice of all warning labels on the machine. The labels have been put there to help maintain a safe working environment. The labels have been designed to withstand washing and cleaning. All labels must remain legible for the life of the machine. Labels should be checked periodically to be sure they can be recognized as warning labels.

If danger, warning or caution labels are needed, indicate the part number, type of label, location of label, and quantity required along with your address and mail to:

**STOELTING**  
**ATTENTION: Customer Service**  
**502 Hwy. 67**  
**Kiel, Wisconsin 53042**

### 2.2 SHIPMENT AND TRANSIT

The machine has been assembled, operated and inspected at the factory. Upon arrival at the final destination, the entire machine must be checked for any damage which may have occurred during transit.

With the method of packaging used, the machine should arrive in excellent condition. **THE CARRIER IS RESPONSIBLE FOR ALL DAMAGE IN TRANSIT, WHETHER VISIBLE OR CONCEALED.** Do not pay the freight bill until the machine has been checked for damage. Have the carrier note any visible damage on the freight bill. If concealed damage and/or shortage is found later, advise the carrier within 10 days and request inspection. The customer must place a claim for damages and/or shortages in shipment with the carrier. Stoelting, Inc. cannot make any claims against the carrier.

### 2.3 MACHINE INSTALLATION



#### **WARNING**

**Installation must be completed by a qualified electrician/refrigeration specialist.**

Incorrect installation may cause personal injury, severe damage to the machine and will void factory warranty.

Installation of the machine involves moving the machine close to its permanent location, removing all crating, setting in place, assembling parts, and cleaning.

- A. Uncrate the machine.

- B. Install the four casters. Turn the threaded end into the machine until no threads are showing. To level, turn out casters no more than 1/4" maximum, then tighten all jam nuts.

- C. The machine must be placed in a solid level position.

#### **NOTE**

*Accurate leveling is necessary for correct drainage of freezing cylinder and to insure correct overrun.*

- D. Machines with air cooled condensers require a minimum of 6" (15,2cm) space on all sides and back for proper circulation.

#### **NOTE**

*In order for the condenser fan motor to work the left side needs to be connected to a power source.*

- E. Machines that have a water cooled condenser require 1/2" NPT supply and drain fittings.

### 2.4 INSTALLING WIRING

- A. Refer to the nameplate on the side panel of the machine for specific electrical requirements. Make sure the power source in the building matches the nameplate requirements. Bring the wires into the junction boxes through the access holes in the bottom rear of the freezer.

#### **NOTE**

*Three phase freezers in areas of unbalanced electrical loads require special attention when connecting input electrical power. The unbalanced leg of power (called wild or high) must be connected to L2 in the junction box.*

- B. Remove the back panel and the junction box cover located at the bottom of the machine.
- C. Install permanent wiring according to local code.
- D. If the line voltage is less than 215V, the fan motor needs to be rewired. Refer to the wiring diagram for details.

#### **NOTE**

*Low incoming voltage affects the fan motor speed and could cause high head pressure errors from the reduced air flow. Rewiring the fan motor prevents the fan speed from decreasing to an unsuitable rate.*

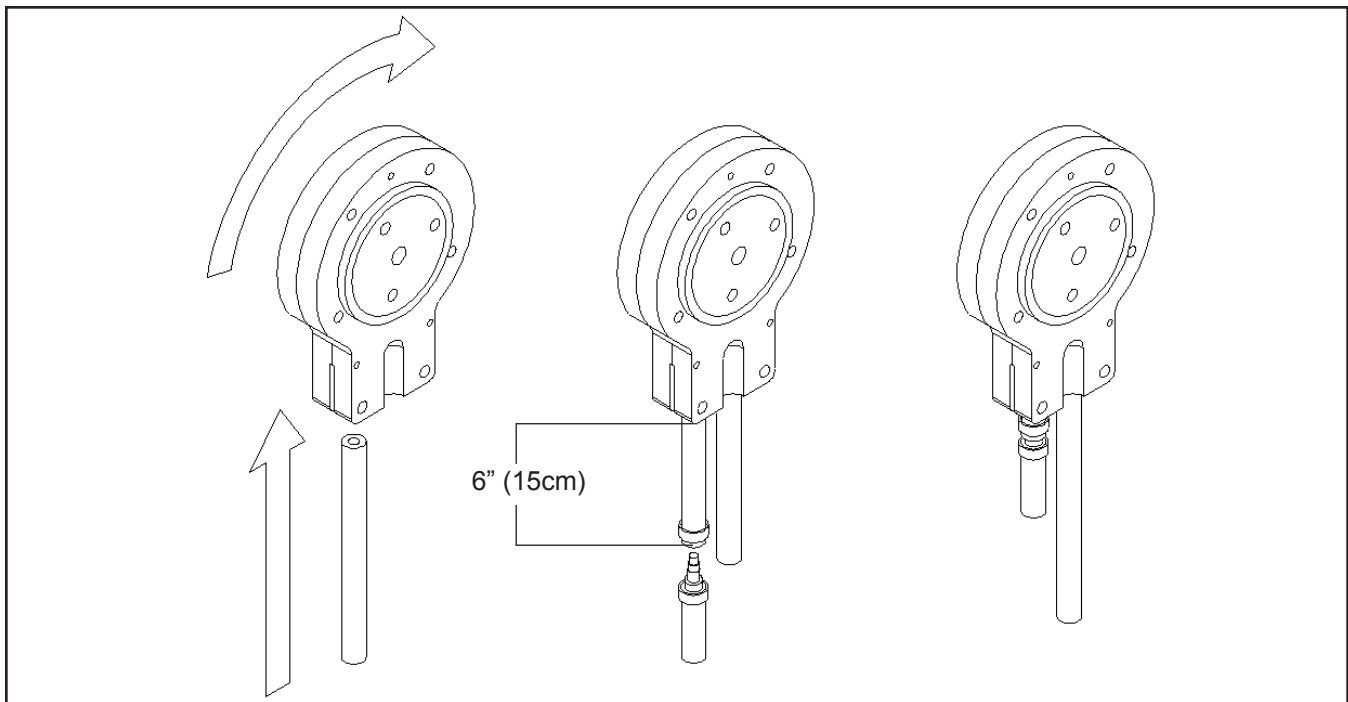

**Figure 2-2 Mix Hose Installation**

## 2.5 CHECK COMPRESSOR FOR PROPER POWER (3 PHASE ONLY)

After connecting the electrical, check that the compressor is operating in the proper direction.

- A. Start a freezing cycle.  
On the right side, place the Main Freezer Power switch and Freezing Cylinder OFF/ON switch to the ON position. Press the PUSH TO FREEZE button.  
On the left side, place the Clean/Off/Serve and the Standby/Serve switches in the Serve position.
- B. The suction line will be cold to the touch within 1 minute.
- C. If it is not, disconnect power to the machine and reverse L1 and L3 lines in the junction box.
- D. After reversing the electrical lines, recheck the suction line.

## 2.6 CHECK BLENDER ROTATION

After connecting the electrical, check the blender on the right side for proper rotation.

- A. Place the Blender Power Off/On switch to the ON position.
- B. With the clear swing shield in place, move the spigot handle to the right.

### **! WARNING**

#### **Hazardous Moving Parts**

Blender shaft and agitator can grab and cause injury. Do not operate blender without protective shield or swing splash shield.

- C. The blender should rotate clockwise looking from the top of the blender.
- D. If the rotation is counterclockwise, refer to the wiring diagram located behind the header panel and check the diode direction. Reverse the diode polarity if needed.

## 2.7 MIX PUMP

### A. MIX PUMP HOSE INSTALLATION

Follow the steps below to install the mix pump hose in the cabinet part of the machine.

1. Turn the mix pump on. The switch is located on the header panel.
2. Feed one end of the mix pump hose into the entering or pickup hose side (left) of black cover (Fig 2-2).

#### **NOTE**

*Feed the tube into the clamp so the natural curve of the tube is towards the outside of the black cover. This prevents the hose from looping around the black cover twice.*

3. Gently push the hose into the black cover until it begins to feed.

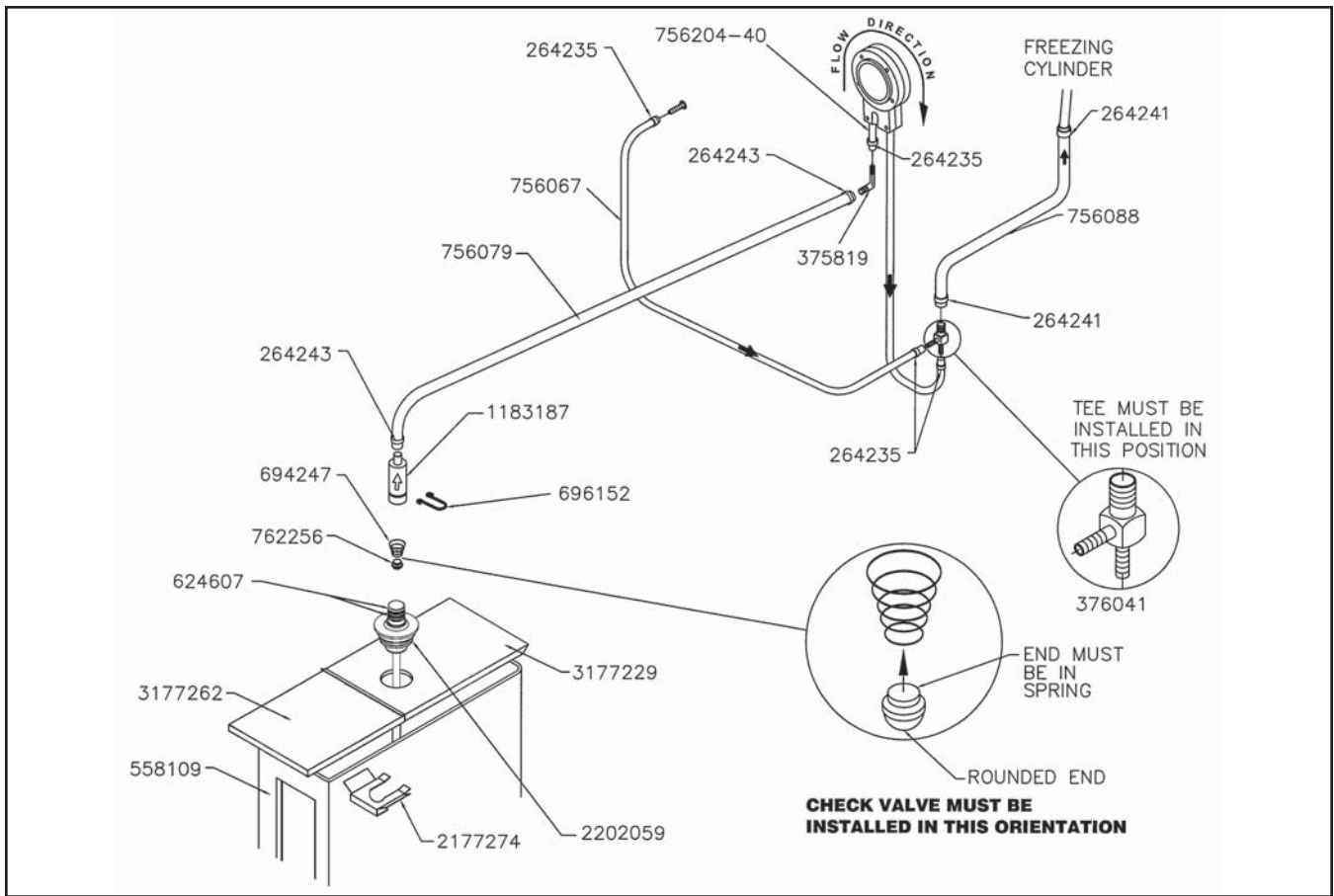

**Figure 2-3 Mix Pump Connections for Standard Mix Container**

4. Allow the hose to feed itself through the pump until about 6" (15cm) remains on the entering side.
5. Turn the pump off.
6. Connect the mix pump hose to the elbow fitting (located on the left side of the mix line manifold) using a small hose clamp. Be careful not to twist the mix hose.
7. Turn the pump on.
8. Allow the remaining 6" (15cm) of tubing to feed through pump until the hose adapter prevents further feeding.
9. Turn the pump off.

**CAUTION**

**Risk of Product Damage**

Air/Mix Tee must remain below the black cover clamp. If the Tee is above the pump, mix may drain into the air compressor resulting in pump damage.

10. Connect the free end of the mix pump hose to the 3-way Tee (Fig. 2-3). When all connections are complete, the 3-way Tee must be lower than the black pump housing.

**B. MIX PICKUP HOSE INSTALLATION**

The machine may be connected to the standard mix container or up to three prepacked mix bags. Follow the instructions below that match your configuration.

**Standard Connection:**

1. Place the mix pickup assembly through the hole in the cover and install the retaining clip.
2. Connect a 24" (61cm) length of 3/8" (9,5mm) ID plastic food grade tubing to the mix pickup assembly. Secure with a hose clamp.
3. Connect the elbow fitting to the free end of the tubing. Connect the opposite end of the elbow to 1/4" ID tan tubing on the left side of the pump head. Secure with hose clamps (Fig. 2-3).

**When Using Bag Connection System (BCS) with Three Bags (optional kit):**

The position of the three bags in the mix container is important. The bag that is connected nearest the outlet of the manifold will drain last and should be placed at the back of the mix container. The mix low level indicator relies on proper bag placement.

1. Connect 3/8" (9,5mm) ID plastic food grade tubing to a bag adapter. Secure with hose clamps.

2. Slide the hose clip over free end of 3/8" (9,5mm) ID plastic food grade tubing. Attach the free end of the tubing to a manifold adapter. Secure with a large hose clamp or equivalent.
3. Push the manifold adapter with spring and valve into the left port (nearest the manifold outlet) of the mix inlet manifold and secure with a retaining clip.
4. Repeat steps 1 to 3 for the middle port and for the right port of the mix inlet manifold.
5. Place three mix bags into the mix container.
6. Connect the bag adapter attached to the left side of the manifold (closest to the mix outlet) to the mix bag in the back of the mix container.
7. Connect the bag adapter attached to the middle of the manifold to the mix bag in the middle of the mix container.
8. Connect the bag adapter attached to the right side of the manifold (farthest from the mix outlet) to the mix bag in the front of the mix container.

6. Place the mix bag(s) into the mix container.
7. Connect the bag adapter attached to the left side of the manifold (closest to the mix outlet) to the mix bag in the back of the mix container.

### C. MIX LOW LEVEL INDICATOR ADJUSTMENT

The sensitivity of the "Mix Low" indication can be adjusted to operator preference. If more advanced notice of low mix is required, loosen the black adjustment knobs located on the sensor brackets at the back of the machine cabinet and slide the bracket upwards. If the "Mix Low" message (right side) or flashing light (left side) appears while there is still sufficient mix in the container, slide the bracket downward. Be sure to tighten the adjustment knobs after properly positioning the sensor.

### When Using Bag Connection System (BCS) with One or Two Bags (optional kit):

When connecting one or two bags, the manifold adapters must be installed closest to the manifold outlet and the manifold plug(s) must be placed farthest from the manifold outlet.

1. Connect 3/8" (9,5mm) ID plastic food grade tubing to a bag adapter. Secure with hose clamps.
2. Slide the hose clip over the free end of the tubing. Attach the free end of the tubing to a manifold adapter. Secure with a large hose clamp.
3. Push the manifold adapter with spring and valve into the left port (nearest the manifold outlet) of the mix inlet manifold and secure with retaining clip. (See Figure 2-4).
4. If using two mix bags, repeat steps 1 to 3 for the middle port.
5. Install a manifold plug into each empty inlet and

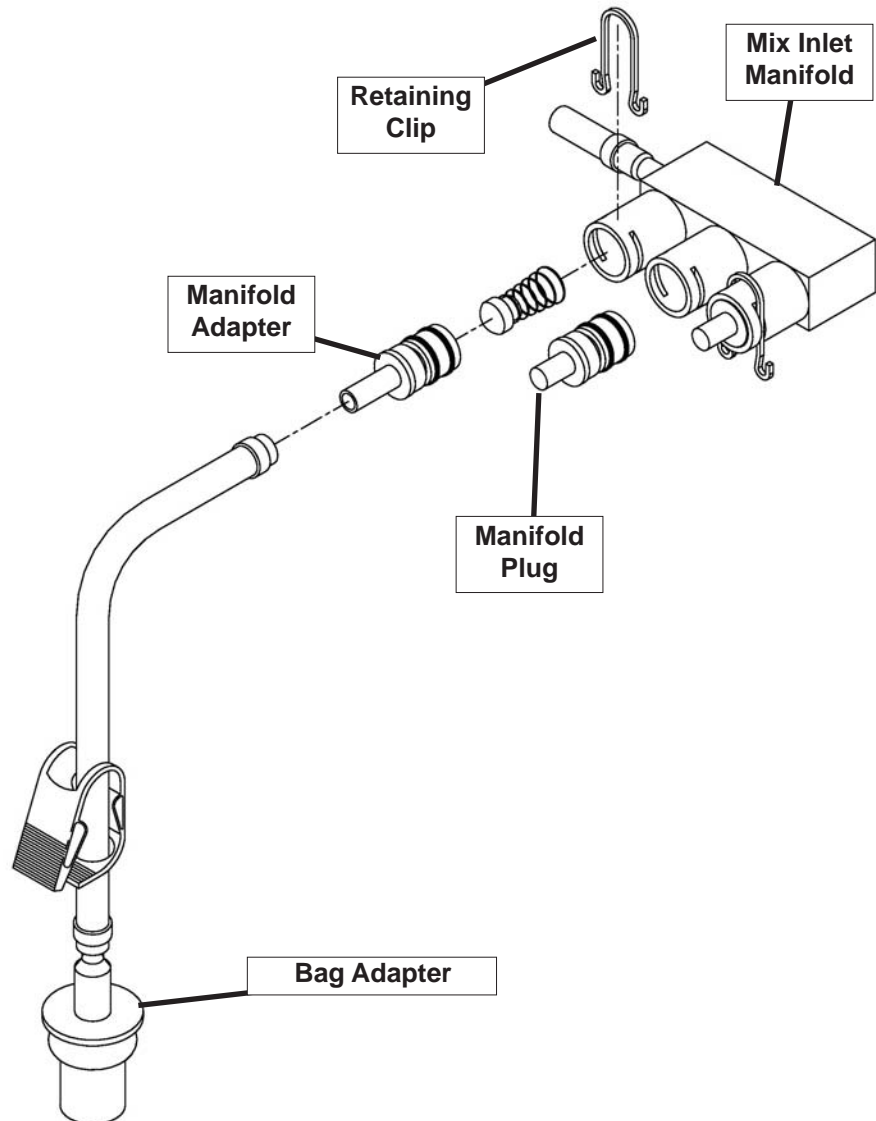

Figure 2-4 Bag Connection System (Optional)

## SECTION 3 INITIAL SET-UP AND OPERATION

### 3.1 OPERATOR'S SAFETY PRECAUTIONS

SAFE OPERATION IS NO ACCIDENT; observe these rules:

- A. Know the machine. Read and understand the Operating Instructions.
- B. Notice all warning labels on the machine.
- C. Wear proper clothing. Avoid loose fitting garments, and remove watches, rings or jewelry that could cause a serious accident.
- D. Maintain a clean work area. Avoid accidents by cleaning up the area and keeping it clean.
- E. Stay alert at all times. Know which switch, push button or control you are about to use and what effect it is going to have.
- F. Disconnect power for maintenance. Never attempt to repair or perform maintenance on the machine until the main electrical power has been disconnected.
- G. Do not operate under unsafe operating conditions. Never operate the machine if unusual or excessive noise or vibration occurs.

### 3.2 OPERATING CONTROLS AND INDICATORS

Before operating the machine, it is required that the operator know the function of each operating control. Refer to Figure 3-1 for the location of the operating controls on the machine. For the information regarding error codes displayed on the control panel, refer to the troubleshooting section of this manual.

#### A. PUMP SWITCH (BOTH SIDES)

The pump motor switch is the toggle switch located under the header panel. When the switch is placed in the OFF position, the pump will not run. When the switch is placed in the ON position, the pump will run until the preset pressure is reached. It then cycles on and off as product is drawn to maintain that pressure.

#### B. SPIGOT SWITCH (BOTH SIDES)

The spigot switch is mounted to the spigot cam assembly behind the header panel. When the spigot is opened to dispense product, the spigot switch opens and the "Serve Mode" begins.

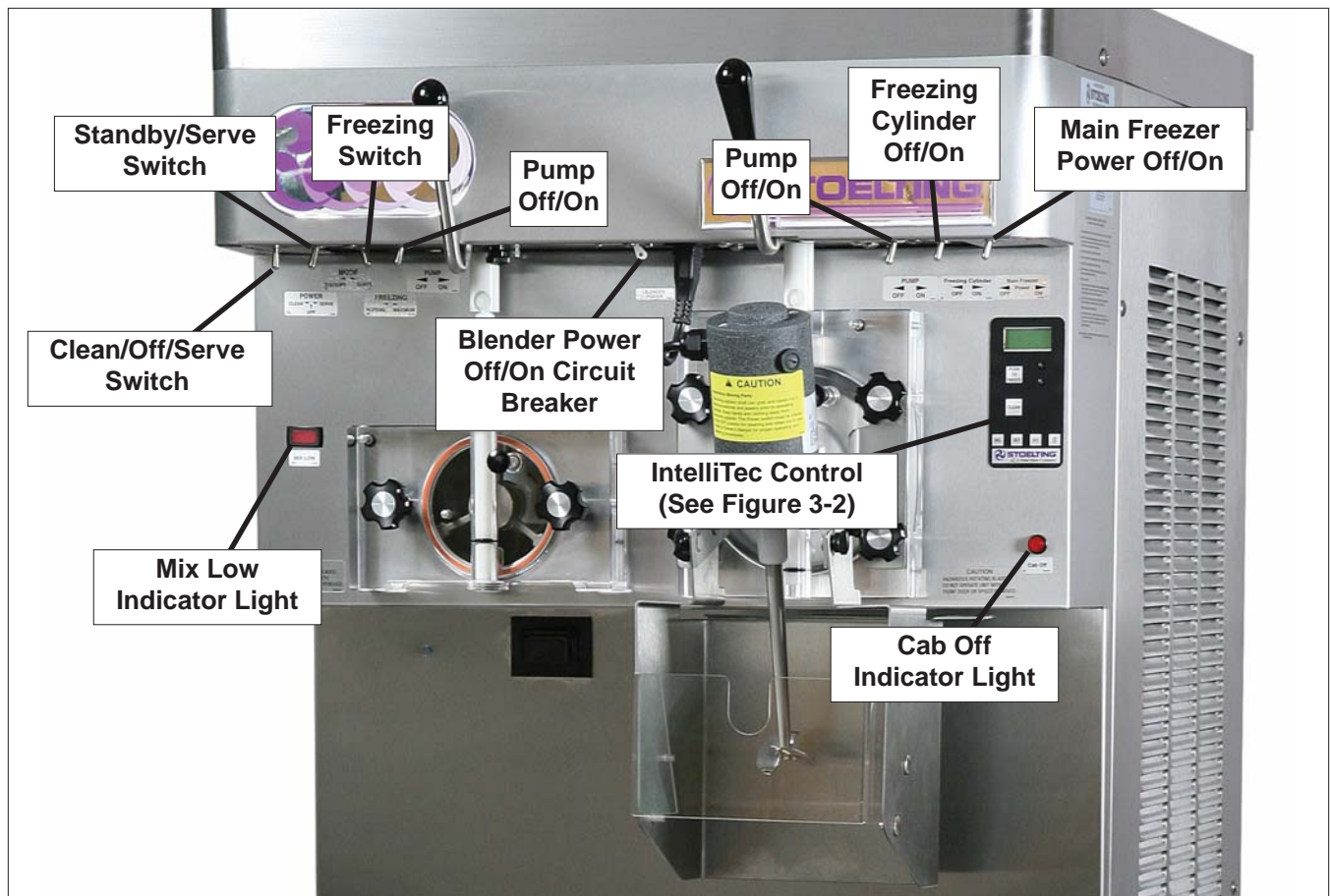

Figure 3-1 SU444 Freezer Controls

### **C. FRONT DOOR SAFETY SWITCH (BOTH SIDES)**

The front door safety switch prevents the auger from turning when the front door is removed. The switch is open when the door is removed and closed when the door is properly installed.

### **D. DRIVE MOTOR OVERLOAD (BOTH SIDES)**

The drive motor overload will trip if the drive motor is overloaded. Single phase machines have an internal overload and three phase machines have an external overload. The overload will reset after approximately 10-12 minutes. If the drive motor continues to trip, refer to the Troubleshooting Section.

### **E. DISPENSE RATE ADJUSTOR (LEFT SIDE)**

The dispense rate adjustor is located under the header panel, to the immediate right of each spigot handle. Turning the knob counterclockwise will decrease the dispense rate.

### **F. CLEAN/OFF/SERVE SWITCH (LEFT SIDE)**

The CLEAN-OFF-SERVE switch is a three position toggle switch used to control the operation of the refrigeration system and auger. When the switch is placed in the CLEAN position, the refrigeration system will be off and auger will rotate for cleaning. When the switch is placed in the OFF position, the refrigeration system and auger will not operate. When the switch is placed in the SERVE position, the refrigeration system and auger will operate automatically. The switch should be placed in the SERVE position for normal operation.

### **G. STANDBY/SERVE SWITCH (LEFT SIDE)**

The standby/serve switch is a two position toggle switch. When the switch is placed in the standby position the machine will cycle to maintain a temperature below 41°F (-15°C). When the switch is in the Serve position the machine will cycle to maintain a servable product.

### **H. FREEZING SWITCH (LEFT SIDE)**

The freezing switch is a two position toggle switch. When the switch is placed in the MAXIMUM position the machine will be forced to run 30 seconds after the spigot is closed if the temperature control is satisfied.

### **I. LOW MIX LIGHT (LEFT SIDE)**

The low mix light will illuminate when the liquid level in the mix container drops below the mix low level indicator. (To adjust the indicator see Section 2.6 C.)

### **J. MAIN FREEZER POWER SWITCH (RIGHT SIDE)**

The Main Freezer Power switch is a two position rocker switch that supplies power to the IntelliTec control, the right freezing cylinder circuits and the cabinet refrigeration system. When the switch is placed in the ON position, the cabinet refrigeration system will run until the preset temperature is reached; then it will cycle ON and OFF to maintain that temperature. Power to the right side freezing cylinder can then be controlled with the Freezing Cylinder OFF/ON switch.

### **K. FREEZING CYLINDER OFF/ON SWITCH (RIGHT SIDE)**

The Freezing Cylinder OFF/ON switch is a two position toggle switch used to supply power to the right freezing cylinder control circuit. When the switch is in the OFF position, the freezing cylinder's refrigeration system and auger will not operate. When the switch is in the ON position, the machine will be operational.

### **L. BLENDER POWER OFF/ON AND CIRCUIT BREAKER SWITCH (RIGHT SIDE - SU444 ONLY)**

The Blender Power Off/On and Circuit Breaker switch is a two position toggle switch used to supply power to the blender. When the switch is in the OFF position, there is no power to the blender. When the switch is in the ON position, the blender will operate any time the spigot handle is pushed to the right. This switch also serves as a circuit breaker to interrupt power if the rotation of the blender agitator becomes hindered.

### **M. CAB OFF INDICATOR LIGHT (RIGHT SIDE)**

A flashing light indicates the Main Freezer Power Switch is in the OFF position; no refrigeration is being supplied to the cab. Place the Main Freezer Power switch in the ON position for cab refrigeration.

### **N. PUSH TO FREEZE BUTTON (RIGHT SIDE)**

The PUSH TO FREEZE button is a snap switch used to initiate "Serve Mode".

#### **NOTE**

*After the PUSH TO FREEZE button is pressed, the drive motor starts. After a 3-second delay, the compressor will start.*

### **O. LEDS (RIGHT SIDE)**

The membrane switch (touchpad) features two lights: a green LED and an amber LED. The green LED is lit during "Serve Mode". During freeze down, it is not lit. When product consistency approaches 75% in the freezing cylinder, the green LED flashes. The amber LED is on during all other modes. Both LEDs alternatively flash if an error occurs or if the freezing cylinder is off.

### **P. CLEAN BUTTON (RIGHT SIDE)**

The CLEAN button is a snap switch. When the button is pressed, the freezing cycle stops and the drive motor will start. A CLEAN message will display on the LCD screen along with a 5-minute countdown timer. To exit the CLEAN mode, turn the Freezing Cylinder OFF/ON switch to the OFF position or press the CLEAN button again. If the machine is left in CLEAN for more than 20 minutes, an error code (E4) will be displayed on the display panel. Place the Freezing Cylinder OFF/ON switch in the OFF position and back in the ON position to clear this error.

### **Q. MIX LOW LIGHT INDICATOR (RIGHT SIDE)**

A MIX LOW message will appear on the LCD display to alert the operator of a low mix condition. The message will display when there is approximately one gallon of mix left in the mix container. When the MIX LOW message is displayed, refill the container or replace a bag immediately.



**Figure 3-2 IntelliTec Control**

### R. MENU NAVIGATION BUTTONS (RIGHT SIDE)

The Menu Navigation Buttons allow the user to display information regarding the machine's status of operation as well as adjust product consistency (Fig. 3-2).

**Selection Button (SEL)** The SEL button is used in combination with the left arrow button to enter into the settings of the IntelliTec control. This button is also used to navigate through the control settings menu.

**Set Button (SET)** The SET button is used to save a change made to the product consistency setting. It is also used to save changes when modifying control settings.

**Left Arrow Button (←)** If the left arrow button is pressed for 5 seconds, the display will remain lit. To turn the light off, press the left arrow button for 5 seconds. The left arrow button is used primarily to navigate through the control settings.

**Up Arrow Button (↑)** After pressing the SET button, the up arrow button will change the value of the product consistency setting. This button is used primarily to navigate through the control settings.

### 3.3 IMPORTANT INFORMATION REGARDING CLEANING AND SANITIZING

Soft serve and shake machines require special consideration when it comes to food safety and proper cleaning and sanitizing.

The following information specifically covers issues for cleaning and sanitizing frozen dessert machines. This information is meant to supplement a comprehensive food safety program.

### SOIL MATERIALS ASSOCIATED WITH FROZEN DESSERT MACHINES

**MILKFAT/BUTTERFAT** – As components of ice-cream/ frozen custard mix, these soils will accumulate on the interior surfaces of the machine and its parts. Fats are difficult to remove and help attribute to milkstone buildup.

**MILKSTONE** – Is a white/gray film that forms on equipment and utensils that are exposed to dairy products. These films will accumulate slowly on surfaces because of ineffective cleaning, use of hard water, or both. Milkstone is usually a porous deposit, which will harbor microbial contaminants and eventually defy sanitizing efforts.

Once milkstone has formed, it is very difficult to remove. Without using the correct product and procedure, it is nearly impossible to remove a thick layer of milkstone.

(NOTE: general-purpose cleaners DO NOT remove milkstone.) This can lead to high bacteria counts and a food safety dilemma.

**IT IS BEST TO CONTROL MILKSTONE ON A DAILY BASIS BEFORE IT CAN BECOME A SIGNIFICANT FOOD SAFETY PROBLEM.**

In addition to food safety, milkstone can cause premature wear to machine parts, which can add to costs for replacement parts or possibly more expensive repairs if worn machine parts are not replaced once they have become excessively worn.

### IMPORTANT DIFFERENCES BETWEEN CLEANING AND SANITIZING

#### CLEANING vs. SANITIZING

It is important to distinguish between cleaning and sanitizing. Although these terms may sound synonymous, they are not. BOTH are required for adequate food safety and proper machine maintenance.

#### CLEANING

- Is the removal of soil materials from a surface.
- Is a prerequisite for effective sanitizing.

#### NOTE

*An UNCLEAN surface will harbor bacteria that can defy sanitizing efforts.*

Bacteria can develop and resist sanitizing efforts within a layer of soil material (milkstone). Thorough cleaning procedures that involve milkstone removal are critical for operators of frozen dessert machines.

#### SANITIZING

- Kills bacteria.
- Can be effective on clean surfaces only.

#### NOTE

*Using a SANITIZER on an unclean surface will not guarantee a clean and safe frozen dessert machine.*

## PROPER DAILY MAINTENANCE:

The Only Way to Assure Food Safety and Product Quality  
Proper daily maintenance can involve a wide variety of products and procedures. Overall, the products and procedures fall into three separate categories. (Please note that this is a brief overview intended for informational purposes only.)

1. **CLEANING** – This involves draining mix from the freezing cylinder and rinsing the machine with water. Next, a cleaner is run through the machine. Then, the machine is disassembled and removable parts are taken to the sink for cleaning.
2. **MILKSTONE REMOVAL** – Since most cleaners do not have the ability to remove milkstone, the use of a delimer becomes necessary. Although this procedure may not be needed on a daily basis, it will usually follow the cleaning procedure. It requires letting a delimer solution soak in the machine for an extended period. Individual parts are also soaked in a deliming solution for an extended period of time (more about delimers in Additional Information).
3. **SANITIZING** – After the machine has been cleaned and contains no milkstone, the machine is reassembled. Then a FDA-approved sanitizing solution is run through the machine to kill bacteria. The machine is then ready for food preparation.

As a recommended cleaner and sanitizer for your frozen dessert machine, STERA-SHEEN has proven to be one of the best daily maintenance products for:

- **CLEANING** – Thorough removal of all solids including butterfat and milk fat.
- **MILKSTONE REMOVAL** – Complete removal of milkstone.
- **SANITIZING** – FDA-approved no rinse sanitizer for food contact surfaces.

## ADDITIONAL INFORMATION

### THE USE OF DELIMERS

A delimer is a strong acid that has the ability to dissolve milkstone. This type of chemical may become necessary once high levels of milkstone have developed. While these products are very effective for removing HIGH levels of milkstone, they are not ideal for two reasons:

1. **PRODUCT SAFETY** – Strong acids are dangerous chemicals. Carefully follow safety instructions provided with delimer products.
2. **MACHINE DAMAGE** – Strong acids will attack metal and rubber causing premature wear of parts. The use of a delimer needs to be closely monitored to avoid damage to machine surfaces and parts.

With proper daily use of STERA-SHEEN or its equivalent, there is no need for the use of a DELIMER.

## DO NOT USE BLEACH

- **BLEACH HAS ABSOLUTELY NO CLEANING PROPERTIES.**
- **BLEACH IS CORROSIVE.** It will damage components of the machine causing premature wear and metal corrosion.

## GENERAL PURPOSE CLEANERS

General purpose cleaners do not have the ability to remove milkstone. Milkstone will become a problem if not remedied with additional products and procedures.

## THE USE OF CHLORINE TEST STRIPS

“Test strips” are used to determine concentrations of active chlorine in sanitizing solutions. To use the strips, tear off a small portion and submerge it into the sanitizing solution. Then, compare the color change to the color key on the side of the test strip dispenser to determine the approximate chlorine concentration.

The ideal concentration of chlorine needs to be 100 ppm (as stated by the FDA).

### NOTE

*Follow the directions on the container for proper concentration.*

Two main factors contribute to falling chlorine concentrations in a sanitizing solution.

1. **PRODUCT USE** – As the chlorine in the solution is being used, chlorine concentrations fall.
2. **TIME** – As time passes, small amounts of chlorine “evaporate” from the solution. (That is why you can smell it.)

Sanitizing solutions should not be allowed to fall below 100 ppm chlorine. New solutions should be mixed once old solutions become ineffective.

## 3.4 DISASSEMBLY OF LEFT SIDE



Moving machinery can grab, mangle and dismember. Place the Clean/Off/Serve switch in the OFF position before disassembling for cleaning or servicing.

Before using the machine for the first time, complete machine disassembly, cleaning and sanitizing procedures need to be followed. Routine cleaning intervals and procedures must comply with the local and state health codes. Inspection for worn or broken parts should be made at every disassembly of the machine. All worn or broken parts should be replaced to ensure safety to both the operator and the customer and to maintain good machine performance and a quality product.

To disassemble the left side, refer to the following steps:

### A. REMOVE FRONT DOOR AND AUGER

1. Make sure the Clean/Off/Serve switch is in the OFF position
2. Remove the knobs on the front door and remove the door by pulling it off the studs.
3. Remove the air bleed valve by unscrewing the knob while holding the valve stem from behind. Remove the compression spring and push the air bleed valve through the rear of the front door.

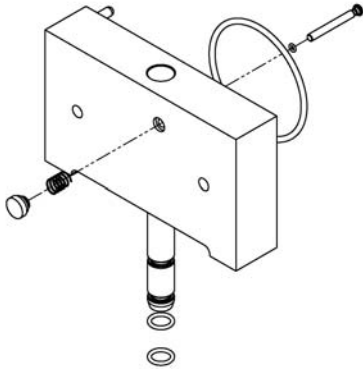

Figure 3-2 Left Side Front Door

4. Remove the spigot through the bottom of the front door. Remove all o-rings from the spigot and the air bleed valve.
5. Remove the front auger support and plastic bearing.
6. Remove the auger by pulling slowly and rotating out of the machine barrel. As the auger is withdrawn, remove each plastic flight and spring from the auger. Be careful not to scratch inside of machine barrel when removing flights or auger. Remove the spring from each auger flight.
7. Keep the rear of the auger tipped up once it is clear of the freezing cylinder to prevent the rear seal assembly from dropping.
8. Wipe the hex drive anti-seize off the hex end of the auger with a paper towel. Remove the rear seal assembly.

#### NOTE

Keep the rear seal assembly separate from the right side assembly to prevent problems when assembling.

### 3.5 DISASSEMBLY OF RIGHT SIDE



#### WARNING

Moving machinery can grab, mangle and dismember. Place the Main Freezer Power Off/On switch in the OFF position before disassembling for cleaning or servicing.

Before using the machine for the first time, complete machine disassembly, cleaning and sanitizing procedures need to be followed. Routine cleaning intervals and procedures must comply with the local and state health codes. Inspection for worn or broken parts should be made at every disassembly of the machine. All worn or broken parts should be replaced to ensure safety to both the operator and the customer and to maintain good machine performance and a quality product.

To disassemble the machine, refer to the following steps:

### A. REMOVE BLENDER (SU444 ONLY)

1. Make sure the Main Freezer Power Off/On switch is in the OFF position.
2. Unplug the blender.
3. Remove the blender agitator by holding the blender shaft and turning the agitator counterclockwise. Remove the blender shaft by holding the blender collar and turning the shaft counterclockwise. (Figure 3-3)

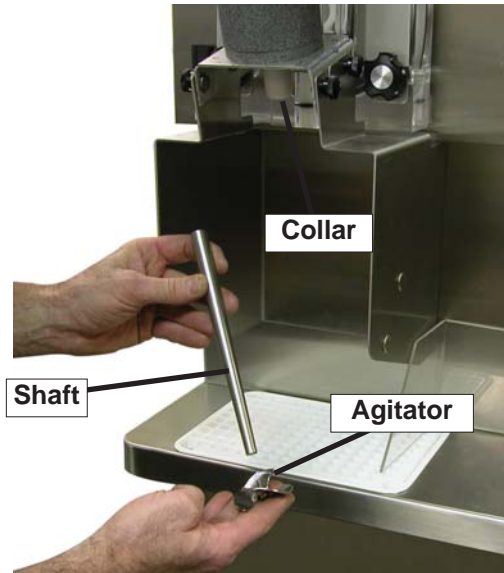

Figure 3-3 SU444 Blender Agitator Assembly

4. Loosen knobs holding the blender splash shield bracket in place and remove the bracket.
5. Remove the knobs on the front door. Remove the blender assembly and set aside.

#### NOTE

Support the blender with one hand while removing the knobs on the door to prevent the blender from dropping.

### B. REMOVE FRONT DOOR AND AUGER

1. Make sure the Main Freezer Power Off/On switch is in the OFF position
2. Remove the knobs on the front door and remove the door by pulling it off the studs.

3. Remove the air bleed valve by unscrewing the knob while holding the valve stem from behind. Remove the compression spring and push the air bleed valve through the rear of the front door.
4. Remove the spigot through the bottom of the front door. Remove all o-rings from the spigot and the air bleed valve.
5. Remove the plastic bearing. The plastic bearing may be on the front door.
6. Remove the auger by pulling slowly. Be careful not to scratch the inside of the freezing cylinder when removing the auger.
7. Keep the rear of the auger tipped up once it is clear of the freezing cylinder to prevent the rear seal assembly from dropping.
8. Wipe the hex drive anti-seize off the hex end of the auger with a paper towel. Remove the rear seal assembly.

**NOTE**

*Keep the rear seal assembly separate from the right side assembly to prevent problems when assembling.*

**3.6 CLEANING DISASSEMBLED PARTS**

Disassembled parts require complete cleaning, sanitizing and air drying before assembling. Local and state health codes will dictate the procedure required. Some state health codes require a four sink process (pre-wash, wash, rinse, sanitize, air dry), while others require a three sink process (without the pre-wash step). The following procedures are a general guideline only. Consult your local and state health codes for the procedures required in your location.

- A. Disassemble all parts.
- B. Place all front door and auger parts in clean 90° to 110°F (32°C to 43°C) water and wash thoroughly (four sink procedure only).

<b>CAUTION</b>
The blender motor cannot be immersed in water or sanitizer. Wash the motor and mounting bracket with a mild detergent solution taking care not to allow water into the motor bearings or seals.

- C. Place all parts in 90° to 110°F (32°C to 43°C) mild detergent water and wash thoroughly.
- D. Rinse all parts with clean 90° to 110°F (32°C to 43°C) water.
- E. Sanitize all machine parts following procedures outlined below.

**3.7 SANITIZING PARTS**

- A. Use a sanitizer, mixed according to manufacturer's instructions, to provide a 100 parts per million strength solution. Mix sanitizer in quantities of no less than 2 gallons of 90° to 110°F (32°C to 43°C) water. Any sanitizer must be used only in accordance with the manufacturer's instructions.
- B. Place all parts in the sanitizing solution for 5 minutes, then remove and let air dry completely before assembling in machine.

**3.8 CLEANING THE MACHINE**

The exterior should be kept clean at all times to preserve the luster of the stainless steel. A high grade of stainless steel has been used on the machine to ease cleanup. To remove spilled or dried mix, wash the exterior with 90° to 110°F (32°C to 43°C) soapy water and wipe dry.

Do not use highly abrasive materials, as they will mar the finish. A mild alkaline cleaner is recommended. Use a soft cloth or sponge to apply the cleaner. For best results, wipe with the grain of the steel.

- A. Clean the rear seal surfaces on the inside of the freezing cylinders.
- B. Using sanitizing solution and the large barrel brush provided, sanitize the freezing cylinders by dipping the brush in the sanitizing solution and brushing the inside of the freezing cylinders.
- C. Remove the drip trays from the front panel. Clean and replace the drip trays.

**3.9 ASSEMBLING THE LEFT SIDE**

Refer to the following steps for assembling the left freezing cylinder:

**NOTICE**

*Petrol-Gel sanitary lubricant or equivalent must be used when lubrication of machine parts is specified.*

**NOTICE**

*The United States Department of Agriculture and the Food and Drug Administration require that lubricants used on food processing equipment be certified for this use. Use lubricants only in accordance with the manufacturer's instructions.*

- A. Assemble all o-rings onto parts dry, without lubrication. Then apply a thin film of sanitary lubricant to exposed surfaces of the o-rings.
- B. Install the rear seal o-ring. Lubricate the outside of the rear seal o-ring with sanitary lubricant.

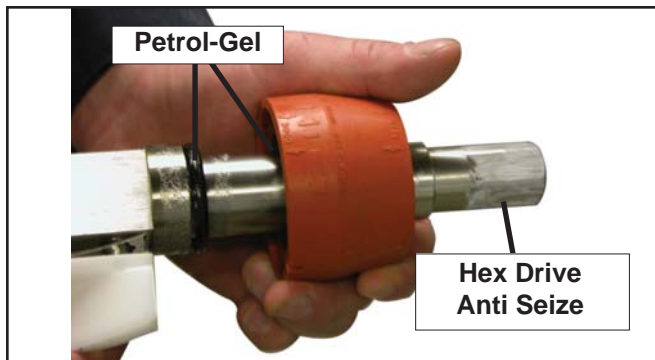

**Figure 3-4 Rear Seal Assembly**

- C. Install the stainless steel rear seal adapter into the rear seal dry (without lubricant). Lubricate the inside surface of the rear seal adapter and install it onto the auger shaft. DO NOT lubricate the outside of the rear auger seal (Fig. 3-4).

**NOTE**

*Make sure to install the correct rear seal adapter onto the auger. The front door will not close if the right side rear seal adapter is installed onto the left side auger.*

- D. Lubricate the hex drive end of the auger with a small amount of spline lubricant. A small container of anti seize is shipped with the machine.
- E. Screw the springs onto the studs in the plastic flights. The springs must be screwed into the flights completely to provide proper compression.
- F. Install the two plastic flights onto the rear of the auger and insert it part way into the freezing cylinder.
- G. Install the remaining plastic flights, push the auger into the freezing cylinder and rotate slowly until the auger engages the drive shaft.
- H. Apply a thin layer of sanitary lubricant to the inside and outside of the auger support bushing. Install the bushing onto the auger support and install the auger support into the front of the auger. Rotate the auger support so that one leg of the support points straight up.
- I. Assemble the air bleed valve o-ring onto the air bleed valve. Position the o-ring into the groove close to the wide part. Apply a thin film of sanitary lubricant to the o-ring.
- J. Insert the air bleed valve into the back of the front door. Install the compression spring onto the air bleed valve then screw the knob on finger tight.
- K. Apply a thin layer of sanitary lubricant to the o-rings on the spigot body and install the spigot body through the bottom of the front door.
- L. Place the front door assembly on the mounting studs and the push front door against the machine carefully.

- M. Secure the front door to the machine by placing the knobs on the studs and tightening until finger tight. Do not overtighten. Proper o-ring seal can be observed through the transparent front door.

**3.10 ASSEMBLING THE RIGHT SIDE**

Refer to the following steps for assembling the right freezing cylinder:

**NOTICE**

*Petrol-Gel sanitary lubricant or equivalent must be used when lubrication of machine parts is specified.*

**NOTICE**

*The United States Department of Agriculture and the Food and Drug Administration require that lubricants used on food processing equipment be certified for this use. Use lubricants only in accordance with the manufacturer's instructions.*

- A. Assemble all o-rings onto parts dry, without lubrication. Then apply a thin film of sanitary lubricant to exposed surfaces of the o-rings.
- B. Install the rear seal o-ring. Lubricate the outside of the rear seal o-ring with sanitary lubricant.
- C. Install the stainless steel rear seal adapter into the rear seal dry (without lubricant). Lubricate the inside surface of the rear seal adapter, including the adapter o-ring, and install it onto the auger shaft. DO NOT lubricate the outside of the rear auger seal.

**NOTE**

*Make sure to install the correct rear seal adapter onto the auger. The back of the cylinder will leak if the left side rear seal adapter is installed onto the right side auger.*

- D. Lubricate the hex drive end of the auger with a small amount of spline lubricant. A small container of anti seize is shipped with the machine.
- E. Install the plastic scraper blades onto the auger and insert the auger into the freezing cylinder.
- F. Rotate the auger until it engages the drive shaft.
- G. Assemble the air bleed valve o-ring onto the air bleed valve. Position the o-ring into the groove close to the wide part. Apply a thin film of sanitary lubricant to the o-ring.
- H. Insert the air bleed valve into the back of the front door. Install the compression spring onto the air bleed valve then screw the knob on finger tight.
- I. Install the spigot through the bottom of the front door.
- J. Apply a thin film of sanitary lubricant to the inside and outside of the plastic bearing, then place it into the front door.

- K. Place the front door assembly on the mounting studs and the push front door against the machine carefully.
- L. On the SU444, place the blender assembly onto the front door studs.
- M. Secure the front door to the machine by placing the knobs on the studs and alternately tightening opposite corners until finger tight. Do not overtighten. Proper o-ring seal can be observed through the transparent front door.
- N. On the SU444, attach the blender shroud to the blender assembly. The blender shroud has a pin that needs to be properly aligned with the machine safety switch.
- D. Place the CLEAN-OFF-SERVE toggle switch in the CLEAN position.
- E. Check for leaks when the machine barrel is first pressurized with sanitizing solution.
  1. Check for leaks at the plastic front door, the O-rings may not be sealed.
  2. Check the drain located at the center of the Drip Tray for leaks coming from the rear of the Rear Auger Seal.
  3. Check inside cab unit for leaks at hose connections.
- F. Using a sanitized soft bristle brush or equivalent, dipped in sanitizing solution, clean mix container.
- G. After five minutes, open spigot to drain sanitizing solution.
- H. Empty any remaining sanitizing solution from the mix container.
- H. Close the spigot and place the mix pump switch and the CLEAN-OFF-SERVE switch in the OFF position.

### 3.11 SANITIZING

Sanitizing must be done after the machine is clean and just before the machine is filled with mix. Sanitizing the night before is not effective. However, you should always clean the machine and parts after using it.

#### NOTE

*The United States Department of Agriculture and the Food and Drug Administration require that all cleaning and sanitizing solutions used with food processing equipment be certified for this use.*

When sanitizing the machine, refer to local sanitary regulations for applicable codes and recommended sanitizing products and procedures. The frequency of sanitizing must comply with local health regulations. Mix sanitizer according to manufacturer's instructions to provide a 100 parts per million strength solution. Mix sanitizer in quantities of no less than 2 gallons of 90°F to 110°F (32°C to 43°C) water. Allow sanitizer to contact the surfaces to be sanitized for 5 minutes. Any sanitizer must be used only in accordance with the manufacturer's instructions.

<b>CAUTION</b>
<p><b>Risk of Product Damage</b></p> <p>Avoid prolonged contact of sanitizer with machine parts. Sanitizer may cause corrosion of stainless steel parts if there is prolonged contact.</p>

#### SANITIZING THE LEFT SIDE

- A. Prepare 3 gallons of sanitizing solution following manufacturer's instructions, and pour into storage container.
- B. Place the mix pump switch in the ON position and open air bleed valve on the front door by pushing valve in and holding.
- C. Let sanitizing solution fill the machine barrel to air bleed valve, then close the valve by pulling out to lock in place.

#### SANITIZING THE RIGHT SIDE

- A. Prepare 3 gallons of sanitizing solution following the manufacturer's instructions. Pour it into a clean container and place the container into the cabinet.
- B. Place the mix pump switch in the ON position and open the air bleed valve on the front door by pushing the valve in and holding.
- C. Let sanitizing solution fill the freezing cylinder to the air bleed valve. Close the valve by pulling it out to lock it into place.
- D. Place the Main Freezer Power OFF/ON and Freezing Cylinder OFF/ON switches in the ON position. Press the CLEAN button.
- E. Check for leaks when the freezing cylinder is first pressurized with sanitizing solution.
  1. Check for leaks at the front door seals.
  2. Check the drain tray located in the side panel for leaks coming from the rear of the rear auger seal.
  3. Check the inside of the cab unit for leaks at the hose connections.
- F. Using a sanitized soft bristle brush (or equivalent) dipped in sanitizing solution, clean the mix container.
- G. After five minutes, open the spigot to drain the sanitizing solution.
- H. Empty any remaining sanitizing solution from the mix container.

- I. When the solution has drained, press the CLEAN button to stop the auger and place the Main Freezer Power OFF/ON and Freezing Cylinder OFF/ON switches in the OFF position. Allow the freezing cylinder to drain completely.
- J. Sanitize the agitator and shaft with a cup filled with sanitizing solution.

The machine is now sanitized and ready for adding mix.

### 3.12 INITIAL FREEZE DOWN AND OPERATION

Every Stoelting machine needs to be set on site. The following information is for the right side and only needs to be performed during the initial startup or when changing the type of mix.

#### NOTE

*The machine is designed for correct operation in ambient temperatures between 50°F and 110°F. Temperatures out of that range may cause refrigeration problems and product quality issues.*

#### A. ADDING MIX

1. Sanitize the machine immediately before use.
2. Make sure the Freezing Cylinder OFF/ON switch is in the OFF position.
3. Fill the mix container in the cab with at least 2.5 gallons of mix.
4. Attach the mix inlet probe to the container and place the container in the refrigerated cab.
5. The mix pump switch is located on the header panel. Place it in the ON position.
6. Place a container under the spigot and open the spigot to allow the mix to flush out about 8 ounces (0.23 liters) of sanitizing solution and liquid mix. Close the spigot.
7. Open the air bleed valve on the front door by pressing and holding. Hold the valve open until the mix level in the freezing cylinder is 1/2" from the air bleed valve.

#### B. PREPARING THE INTELLITEC CONTROL

8. On the IntelliTec control, press and hold the SEL button for 8 seconds. While still holding the SEL button, press the up arrow (↑) button. The LCD will read "DISPLAY".
9. Press the left arrow (←) button once. The display will read "BASIC".
10. Press the up arrow (↑) button once. The display will read "CutOut amps".
11. Press the SET button. A cursor will start blinking under the far right digit.
12. Change the value to 8.0. Press the left arrow (←) button to move the cursor. Press the up arrow (↑) button to increase the digit. When a digit reaches 9, pressing the up arrow (↑) button again will change the value to 0.

13. After entering 8.0, press SET to save this value. The LCD will read "CutOut Set — OK".
14. Press the SEL button. The LCD will read "CutOut amps 8.0".
15. Press the SEL button twice. The LCD will read "DISPLAY".
16. Press the up arrow (↑) button to navigate to the "°F" and "amps" readings.

#### C. INITIAL FREEZE DOWN

17. Place the Freezing Cylinder OFF/ON switch in the ON position.
18. Press the PUSH TO FREEZE button.

#### NOTE

*After the drive motor starts, there is a 3-second delay before the compressor starts.*

19. As the product freezes, the "amps" value on the display will increase. When it reaches 2.8A, open the spigot, take a 6-8 ounce sample and measure the temperature. For most shake mixes, the desired temperature is between 23.5°F and 24.0°F.

#### CAUTION

Do not exceed 3.5 amps when setting the control.

20. Draw samples at every increase of 0.2A until reaching the desired consistency and temperature.

#### NOTE

*Show the sample to the customer and make sure it meets their required consistency and temperature.*

21. Record the "amps" value.
22. Place the Freezing Cylinder OFF/ON switch in the OFF position.

#### D. ADJUSTING THE INTELLITEC CONTROL

23. Press the SEL button. The display will read "DISPLAY".
24. Press the left arrow (←) button once. The display will read "BASIC".
25. Press the up arrow (↑) button once. The display will read "CutOut amps".
26. Change the value to the recorded value by pressing the SET button. A cursor will start blinking under the far right digit.
27. Press the left arrow (←) button to move the cursor. Press the up arrow (↑) button to increase the digit. When a digit reaches 9, pressing the up arrow (↑) button again will change the value to 0.
28. Press the SET button to save the value. The LCD will read "CutOut Set — OK".

29. Press the SEL button. The LCD will read “CutOut amps” along with the programmed value from the previous step.
30. Press the SEL button three times. The LCD will read “EXITMENU”.
31. Press the up arrow (↑) button to exit the menu.
32. Adjustment to the control is completed.

### E. SERVING PRODUCT

33. Place the Freezing Cylinder OFF/ON switch in the ON position.
34. Press the PUSH TO FREEZE button.
35. When the product is at 75% consistency, the display will read “SERVE”.
36. For normal dispensing, move the spigot handle fully open.
37. The machine dispenses product at a reasonable draw rate. If the machine is overdrawn, the result is a soft product or a product that will not dispense at all. If this occurs, allow the machine to run for approximately 30 seconds before dispensing more product.
38. Do not operate the machine when the MIX LOW message is displayed. Refill the mix container immediately.

#### NOTE

*The right side has a standby and sleep mode. After a preset number of freezing cycles, it will enter the standby mode (followed by sleep mode) and remain there until someone draws product or presses the PUSH TO FREEZE button. In the sleep mode, the machine will keep the product below 41°F (7.2°C). Sleep modes do not take the place of cleaning and sanitizing. Federal, State, and local regulatory agencies determine frequency of cleaning and sanitizing.*

### 3.13 NORMAL FREEZE DOWN AND OPERATION

Refer to the following procedures to operate both freezing cylinders.

- A. Sanitize immediately before use.
- B. Make sure the Clean/Off/Serve switch (left side) or the Freezing Cylinder Off/On switch (right side) is in the OFF position.
- C. Fill the storage container in the cab with at least 2.5 gallons of mix.
- D. Attach the mix inlet probe to the container and place the container in the refrigerated cab.
- E. Place the mix pump switch in the ON position.

- F. Place a container under the spigot and open it to allow the mix to flush out about 8 ounces (0.23 liters) of sanitizing solution and liquid mix. Close the spigot.
- G. Open the air bleed valve on the front door by pressing and holding. Hold the valve open until the mix level in the freezing cylinder is 1/2” from the air bleed valve.
- H. Place the Clean/Off/Serve switch (left side) or the Freezing Cylinder Off/On switch (right side) in the ON position. On the SU444 right side, make sure the blender power plug is connected to the machine and place the Blender Power Off/On switch in the ON position.



#### WARNING

##### Hazardous Moving Parts

Blender shaft and agitator can grab and cause injury. Do not operate blender without protective shield or swing splash shield.

- I. On the right side, press the PUSH TO FREEZE button.

#### NOTE

*After the drive motor starts, there is a 3-second delay before the compressor starts.*

- J. Product will be ready as follows:  
On the left side, the product will be ready to serve after about 3 cycles.  
On the right side, the display will read “SERVE” when the product is at 75% consistency.
- K. For normal dispensing, fully open the spigot handle.
- L. On the SU444 right side, push the spigot handle to the right to activate the blender. The blender will operate during or after dispensing product.
- M. Do not operate the right side when the MIX LOW message is displayed and do not operate the left side when the mix low indicator light is on. Refill the mix containers immediately.

#### NOTE

*The right side has a standby and sleep mode. After a preset number of freezing cycles, it will enter the standby mode (followed by sleep mode) and remain there until someone draws product or presses the PUSH TO FREEZE button. In the sleep mode, the machine will keep the product below 41°F (7.2°C). Sleep modes do not take the place of cleaning and sanitizing. Federal, State, and local regulatory agencies determine frequency of cleaning and sanitizing.*

### 3.14 MIX INFORMATION

Mix can vary considerably from one manufacturer to another. Differences in the amount of butterfat content and quantity and quality of other ingredients have a direct bearing on the finished frozen product. A change in machine performance that cannot be explained by a technical problem may be related to the mix.

Proper product serving temperature varies from one manufacturer's mix to another. Mixes should provide a satisfactory product in the 20°F to 24°F range. Diet and low-carb mixes typically freeze to proper consistency at higher temperatures.

When checking the temperature, stir the thermometer in the frozen product to get an accurate reading.

Old mix, or mix that has been stored at too high a temperature, can result in a finished product that is unsatisfactory. To retard bacteria growth in dairy based mixes, the best storage temperature range is between 33° to 38°F (0.5° to 3.3° C).

### 3.15 OPERATION OF MIX PUMP

The mix pump switches are located under the header panel. When a pump switch is placed in the ON position, the mix pump motor will start pumping mix into the freezing cylinder. When the set pressure is reached, the mix pump will shut off automatically. When the switch is placed in the OFF position, the mix pump will not operate.

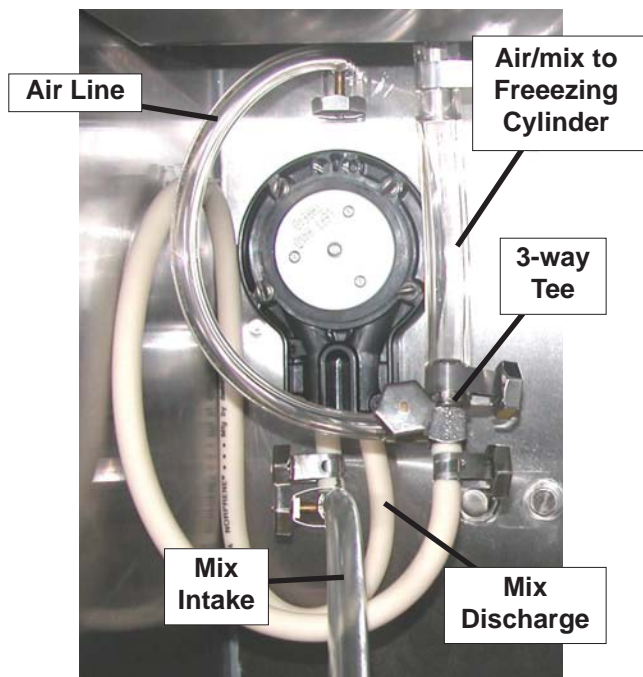

Figure 3-5 Mix Pump Hose Routing

### NOTE

*The mix pump motor is equipped with an internal overload that will “trip”, disabling the pump when the motor is overloaded. Consult the troubleshooting section for corrective information. The internal overload will automatically reset after cooling. If the condition continues, contact a qualified service person.*

- A. Mix Operation: The peristaltic mix pump contains one continuous mix pump hose. When looking at the face of the peristaltic mix pump, the left side of the hose is the mix intake or pickup. The right side of the hose is the mix discharge. Mix is drawn up the pickup side of the hose and transferred through the discharge side to the machine (Fig. 3-6).
- B. Air Operation: The air compressor operates whenever the peristaltic mix pump is running. Air enters through a check valve on the piston downstroke. The air is discharged through a second check valve, on the piston upstroke. The air and mix join at the tee and then travel to the machine.
- C. The overrun adjustment is preset at the factory. If an adjustment becomes necessary, refer to Section 4.

### 3.16 MIX PUMP CLEANING

#### NOTICE

*Any cleaning procedure must always be followed by sanitizing before filling machine with mix. (Refer to Section 3.11)*

The mix pump is approved for CIP (clean in place). It is thoroughly cleaned when the detergent solution is pumped through the machine. We recommend completely disassembling the pump and disconnecting tubing every 14 days for inspection of parts to confirm the CIP has been properly performed. If any residue is detected, clean or replace those parts as outlined below.

- A. Place the Main Freezer Power OFF/ON switch and the Freezing Cylinder OFF/ON switch in the ON positions. Make sure both Pump OFF/ON switches are in the ON position. Place the Clean/Off/Serve switch (Left Side) in the CLEAN position and press the CLEAN button (Right Side). Allow the auger to agitate for 5 to 10 minutes.
- B. Remove the suction tube from the mix container. Open the spigot to remove the mix remaining in the freezing cylinder.
- C. Pump 2 gallons (7.5 liters) of potable water through machine until the water coming out of the spigot is clear.

- D. Pump 2 gallons (7.5 liters) of 90° to 110°F (32°C to 43°C) detergent solution through the machine. The use of soft water is recommended, along with dishwashing detergents such as “Joy,” “Dawn,” or equivalent.
- E. Place the mix pump switch in the OFF position. Open the spigot to relieve the remaining pressure.
- F. Place the Clean/Off/Serve switch (Left Side) in the OFF position and press the CLEAN button (Right side) to stop the augers. Place the Main Freezer Power OFF/ON switch and the Freezing Cylinder OFF/ON switch in the ON positions.

### 3.17 DISASSEMBLY AND INSPECTION OF REMOVABLE PARTS

Inspection of removable parts should be made whenever maintenance is performed or when the pump requires disassembly.

#### NOTE

*If the mix line or air line is difficult to remove, soften the tubing with a rag soaked in hot water. Hose connections may be sprayed with Haynes Sanitary Lubricant for ease of removal.*

#### WARNING

##### Hazardous Moving Parts

Revolving pump head can grab, mangle, and cause serious crushing injury. The Main Freezer Power OFF/ON switch, the Clean/Off/Serve switch and the Freezing Cylinder OFF/ON switch must be placed in the OFF position for cleaning and power must be disconnected when disassembling or servicing.

#### CAUTION

##### System Under Pressure

Never disconnect hoses from the machine or the pump without first opening the spigot to relieve pressure.

- A. Loosen the clamp and remove the air hose from the pump compressor.
- B. Loosen the clamp and disconnect the mix pump hose. Remove the pickup hose, and the mix pickup assembly from the mix container.
- C. Completely disassemble the hose assembly and the check valve. Place hoses, tee, check valve assembly, and pickup hose adapter in 90° to 110°F (32°C to 43°C) mild detergent water and wash thoroughly. Use soft bristle brushes to clean inside of fittings. Rinse all parts in clean 90° to 110°F (32°C to 43°C) water.
- D. Carefully inspect each part for wear or damage. Replace worn or damaged parts.
- E. Wash the mix tube and the air tube in the cabinet with 90° to 110°F detergent water and brushes provided. Rinse with clean, 90° to 110°F water.
- F. Prepare two gallons (7.5 liters) of sanitizing solution using a USDA certified grade sanitizing solution. Sanitize all removed parts. Allow them to air dry.
- G. Reassemble both hose assemblies per the diagram located on the inside of the cab door. Reconnect the assemblies to the pump hose and the discharge hose, using the clamps. (Refer to Section 2.5 Mix Pump).
- H. Sanitize assembled machine as per instructions outlined in Section 3.11.



Figure 3-6 Mix Pump Removable Parts

## SECTION 4 MAINTENANCE AND ADJUSTMENTS

### 4.1 MACHINE ADJUSTMENT

This section is intended to provide maintenance personnel with a general understanding of machine adjustments. It is recommended that any adjustments in this section be made by a qualified person.

### 4.2 PRODUCT TEMPERATURE ADJUSTMENT (LEFT SIDE)

A potentiometer is used to control the product temperature. To change the temperature of the product, follow the steps below:

- A. Remove the header panel.
- B. Use a screw driver to make desired adjustment. A label near the potentiometer will give complete instructions.



Figure 4-1 Left Side Product Temperature Control

### 4.3 PRODUCT CONSISTENCY ADJUSTMENT (RIGHT SIDE)

The operator can adjust product consistency by modifying the Fine Adjustment setting on the membrane switch. This is the only adjustment that can be made by the operator without using a pass code key sequence. Product consistency fine adjustment allows a 0.4 amp maximum adjustment to the drive motor amp draw cutout. Increasing this setting will increase the drive motor amperage cutout and increase product consistency. Follow the instructions below to make fine adjustments to product consistency.

- A. Place the Main Freezer Power switch in the ON position.
- B. Press the SET button on the Control Panel once. Fine Adj will appear on the LCD screen.
- C. Press the up arrow button (↑) until the desired consistency setting is displayed. The higher the number, the firmer the product consistency. The

control may be set from 1 to 9. The value increases by 1 each time the up arrow button is pressed. After the value reaches 9, numbering restarts at 0. The 0 setting cannot be set.

- D. Press the SET button once to save the setting and return to the current mode display.

### 4.4 LOCKING THE CONTROL PANEL (RIGHT SIDE)

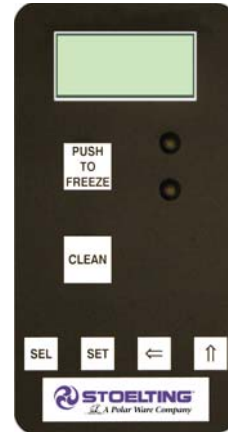

Figure 4-2 Right Side Membrane Switch

The IntelliTec control has a tamper proof mode to prevent unauthorized use. When set, all buttons on the control panel are disabled. Follow the instructions below to lock the control panel

- A. Press and hold the PUSH TO FREEZE button for at least 5 seconds.
- B. While still holding the PUSH TO FREEZE button, press the CLEAN button once.
- C. Release both buttons. An asterisk (\*) will appear on the bottom line of the display, indicating that the control is in the lock out mode.

**NOTE:**

*Repeat steps A, B, and C to unlock the control panel.*

### 4.5 OBTAINING READINGS AND MODIFYING SETTINGS (SERVICE PERSONNEL ONLY) (RIGHT SIDE)

Readings and settings on the IntelliTec control are accessed through the IntelliTec control menu settings. Locating machine readings and system function settings are done using the up arrow (↑) and left arrow (←) buttons on the membrane switch. A printed IntelliTec Menu Settings sheet is located in the information pouch behind the header panel.

## IntelliTec Control Readings

To obtain machine readings, locate the value on the machine's menu settings sheet and follow the steps below.

- A. Press and hold the SEL button for 8 seconds. While still holding the SEL button, press the up arrow button (↑). The LCD screen will read DISPLAY.
- B. Release both buttons.
- C. Press the up arrow button (↑) to navigate to the correct reading under DISPLAY or press the left arrow (←) button to navigate to the ERRCODES menu.
- D. Press the up arrow (↑) and left arrow (←) buttons to navigate through the rest of the readings as needed.
- E. When all readings have been obtained, press the up arrow button (↑) from ExitMenu to return to the current mode display.

## Modifying Control Settings

To change the value of a system function, locate the function on the IntelliTec Settings Menu and follow the steps below.

### IMPORTANT:

*Before making changes to any settings, record the original values. If the setting changes do not achieve desired results, return settings to their original values.*

- A. Press and hold the SEL button for 8 seconds. While still holding the SEL button, press the up arrow button (↑). The LCD Screen will read DISPLAY.
- B. Release both buttons.
- C. Press the left arrow button (←) to get to the correct menu (Basic, Advanced, or Storage).
- D. Press the up arrow button (↑) to navigate to the value that needs to be changed.
- E. Press the SET button to enter the edit mode.
- F. Press the up arrow button (↑) to change the setting.
- G. Press the SET button to save the setting and exit the edit mode.
- H. Press the up arrow (↑) and the left arrow (←) buttons to navigate through the rest of the settings as needed.
- I. When all changes have been completed, press the up arrow button (↑) from ExitMenu to return to the current mode display.

## 4.6 READINGS (SERVICE PERSONNEL ONLY) (RIGHT SIDE)

The IntelliTec control continuously monitors and records temperatures, voltages, amps, and error code details. Each reading is beneficial to service personnel when troubleshooting.

### DISPLAY READINGS

Following are the readings available under the DISPLAY menu:

#### Cabinet

The temperature of the cab is constantly monitored by the IntelliTec control.

#### Cycles (count)

This reading counts down the number of cycles in the current "Serve Mode". The starting value is dependant upon the Cycles setting on the IntelliTec control.

#### °F and amps

Suction line temperature on the freezing cylinder and drive motor amps are available on the same screen to assist with setup and troubleshooting.

#### Aux. Temp (°F)

This reading provides the ambient temperature around the IntelliTec control board.

#### Supply V (VAC)

A calculated input voltage is recorded.

### ERROR CODE READINGS

The following details are recorded under the ERRCODES menu for each of the last 25 error codes received:

#### Err1 (hours)

A numerical count of the last 25 error codes is recorded. When the 26th error has occurred, the earliest error code is erased. A timer also begins when an error occurs. The timer records the number of hours since the error occurred. If power to the machine is interrupted, the timer will stop until power has been restored.

#### °F and amps

The suction gas temperature on the freezing cylinder and the drive motor amps are recorded at the time of the error.

#### Aux. Temp (°F)

Ambient temperature of the IntelliTec control board is recorded at the time of the error.

#### Str (°F)

The storage temperature is recorded at the time of the error.

## VAC and Mode

A calculated input voltage and mode at which the error occurred are recorded. Following are descriptions of each mode:

Mode	Description
0	Start of freezing cycle
1	Compressor and drive motor on
2	Stir Cycle
3	Compressor off
4	“Standby Mode”
5	“Sleep 1 Mode”
6	“Sleep 2 Mode”
7	“Clean Mode”
8	Startup
9	Storage only refrigeration
10	Freezing cycle is shut down
11	Door safety switch triggered
12	High pressure cutout

## Up Time (hours)

This value is a record of the total time the machine has been in service. If power is interrupted, the timer will stop until power is restored. This timer does not reset.

## RUN STATISTICS

In addition to dynamic readings and recorded error code details, the IntelliTec control records rolling averages of run statistics. Following are the readings available under the RUNSTATS menu:

### On Times (sec)

The control records the time of each freezing cycle and provides a rolling average.

### Off Times (sec)

The control records the time between freezing cycles and provides a rolling average.

### Brl. Min (°F)

The lowest average barrel temperature is recorded.

### Brl. Max (°F)

The highest average barrel temperature is recorded.

### Stor Min (°F)

The lowest average cabinet temperature is recorded.

### Stor Max (°F)

The highest average cabinet temperature is recorded.

### Power On (hrs)

This value is a record of the time the machine has been in service. If power is interrupted, the timer will reset.

## 4.7 ADJUSTMENTS (SERVICE PERSONNEL ONLY) (RIGHT SIDE)

The following adjustments directly affect product consistency and length of time in “Serve Mode”. The default settings have been created using a 5% milkfat soft serve mix and provide optimal product consistency while prolonging product life.

### CutOut (amps)

It is recommended to set the CutOut value at initial startup and when changing mix types. Adjustments to this setting directly affect the length of the freezing cycle which changes product consistency. To properly set the CutOut value, refer to section 3-10.

### Cut In T (°F)

After the consistency value has been determined, the Cut In T value can be adjusted. The Cut In T is the temperature of the refrigerant gas in the evaporator. Changing this setting changes the temperature at which the freezing cycle starts. This value along with the CutOut value determines the range of temperatures (or “temperature window”) of the product. Decreasing the temperature decreases the temperature window and, under normal use, increases the amount of freezing cycles. This creates a greater chance of product breakdown by stirring the product often. Increasing the Cut In T increases the temperature window, which decreases freezing cycles and increases the chance of heat shock within the product.

### Cycles (count)

This setting determines the number of freezing cycles during “Serve Mode”. Increasing the value will increase the total time in “Serve Mode”. Factory default is 20 cycles, which results in “Serve Mode” lasting about 2-1/2 hours without the PUSH TO FREEZE button being pressed or a spigot handle being pulled. If the PUSH TO FREEZE button is pressed or the spigot handle is pulled at any time during “Serve Mode”, the Cycles count will reset.

## 4.8 OTHER SETTINGS (SERVICE PERSONNEL ONLY) (RIGHT SIDE)

Changing any setting on the IntelliTec control will alter machine operation and affect the product temperature, consistency, or life. Refer to the IntelliTec Control System Settings sheet located in the information pouch behind the header panel of the machine. If any of the following settings on the IntelliTec control differ from the System Settings sheet, it is recommended to return those settings to factory defaults.

### Stir On (sec)

Adjustments to this setting affect the amount of time the auger rotates in the stir cycle. The stir cycle occurs in "Serve Mode", "Standby Mode", and "Sleep 2 Mode".

### Stir Off (sec)

Adjustments to this setting affect the time between stir cycles. The stir cycle occurs in "Serve Mode", "Standby Mode", and "Sleep 2 Mode".

### On Time (sec)

Increasing this value will increase the length of the freezing cycle during "Standby Mode".

### Off Time (sec)

Increasing this value will increase the time between freezing cycles in "Standby Mode" and result in an increase of product temperature in the barrel.

### Stb Time (sec)

This setting determines the total amount of time in "Standby Mode".

### SI1DrvOn (sec)

Adjustments to this setting affect the amount of time the auger rotates in the stir cycle. This stir cycle only occurs in "Sleep 1 Mode".

### SI1DrOff (sec)

Adjustments to this setting affect the time between stir cycles. The stir cycle only occurs in "Sleep 1 Mode".

### SI2CutIn (°F)

Changing this setting affects the temperature at which the freezing cycle starts in "Sleep 2 Mode".

### SI2CtOut (°F)

Changing this setting affects the temperature at which the freezing cycle stops in "Sleep 2 Mode".

### DftOffTm (sec)

In "Serve Mode", this value determines the maximum time without a freezing cycle. If this value is met, a freezing cycle will start. In the event of a freezing cylinder temperature sensor failure, this value affects the amount of time between freezing cycles during "Serve Mode".

## Refriger

This setting changes how the control handles the storage refrigeration cycle. The correct setting for the SU444 and U444A is Cabinet.

### CabCutIn (°F)

If the Refriger value is set to Cabinet, this setting determines the temperature at which the refrigeration cycle starts. If None, 1 Hopper, or 2 Hopper is selected for the Refriger setting, CabCutIn will not be shown on the IntelliTec menu.

### CabCtOut (°F)

If the Refriger value is set to Cabinet, this setting determines the temperature at which the refrigeration cycle stops. If None, 1 Hopper, or 2 Hopper is selected for the Refriger setting, CabCtOut will not be shown on the IntelliTec menu.

### Cab Off

If the Refriger value is set to Cabinet and the temperature sensor in the cabinet fails, this setting determines the time between refrigeration cycles. If None, 1 Hopper, or 2 Hopper is selected for the Refriger setting, Cab Off will not be shown on the IntelliTec menu.

### Cab On

If the Refriger value is set to Cabinet and the temperature sensor in the cabinet fails, this setting determines the length of the refrigeration cycle. If None, 1 Hopper, or 2 Hopper is selected for the Refriger setting, Cab On will not be shown on the IntelliTec menu.

## 4.9 OVERRUN ADJUSTMENT

The product, when served, is a combination of air and mix. Overrun is a measure of the amount of air blended into the mix.

Overrun can be expressed in terms of the amount of weight loss for a given volume. For example, if a pint of liquid mix weighs 18 ounces and a pint of frozen product with air added weighs 12 ounces, the overrun is said to be 50 percent:  $18 \text{ oz.} - 12 \text{ oz.} = 6 \text{ oz.}$ ,  $(6/12) \times 100 = 50\%$

The overrun can be checked by placing a one pint container on an ice cream scale and zeroing out the scale. Then fill a one pint container with frozen product. The container should be filled over the top and leveled with a straightedge. The product should not contain any air pockets. When weighed on an ice cream scale, one pint of product should weigh 12 to 13 ounces.

The mix pump has been preset at the factory to produce a product with approximately 40% overrun. Because of differences in mix formulation, temperatures and barometric pressure, this figure may vary. It will be necessary for approximately 2 gallons of mix to be pumped through the machine before overrun changes in the product are noticeable.

Overrun is controlled by the length of the air compressor piston stroke within the piston cylinder. Lengthening the stroke within the cylinder will increase overrun. Conversely, shortening the stroke will decrease overrun. To perform an overrun adjustment, refer to the following procedure:

 <b>WARNING</b>
<b>Hazardous voltage</b> The Clean/Off/Serve and the Main Freezer Power Off/On switches must be placed in the OFF position when disassembling for servicing. The freezer must be disconnected from electrical supply before removing any access panel. Failure to disconnect power before servicing could result in death or serious injury.

- A. Turn the mix pump switch to the OFF position. Disconnect power sources/circuit breakers.
- B. Remove the back panel from the machine.
- C. On the air compressor side of the pump, locate the long/slender piston rocking arm. The rocking arm downward travel is limited by a stationary cam. On the face of the cam there is an overrun setting indicator plate numbered 3 through 8 and an adjustment knob (Fig. 4-3).
- D. The overrun setting is indicated by a pin.
- E. To adjust overrun, loosen the allen-head screw (located within the center of the adjustment knob) with the 5/32" allen wrench provided. Rotate the adjustment knob counterclockwise to a higher number for higher overrun, or clockwise to a lower number for lower overrun. Each number multiplied by 10 represents the overrun percentage (i.e. setting 4 = 40% overrun).



Figure 4-3 Overrun Adjustment

- F. Tighten the allen screw, then place the wrench back in its clip. Replace the lower back panel and secure with the four screws. Turn the mix pump power switch to the ON position.

#### 4.10 MIX PUMP HOSE REPOSITION

Mix pump hose must be repositioned every 800 gallons of mix pumped or every 2 weeks. Failure to reposition the hose will result in reduced mix pump liquid capacity, dispense stoppage, popping, and possible mix pump hose leakage. Follow the steps below to reposition the hose:

- A. Run cleaning solution through pump.
- B. Turn the pump off and relieve any pressure by opening the spigot.
- C. Grasp the pickup hose end of the mix pump hose with one hand and turn the pump on. Pull down on the pickup hose end until 12 to 14 inches of tubing has fed through the pump then turn the pump off (Fig. 4-4).
- D. Loosen the small clamp at the pick-up hose adapter and disconnect the mix pump hose.
- E. Cut 7-1/2 inches off the end of the mix pump hose.
- F. Reconnect the mix pump hose to the adapter.
- G. Continue normal operation. Mix hose will automatically reposition itself with the adapter near the black cover.

#### NOTE

*Each hose is long enough for 3 repositions before replacement is required.*

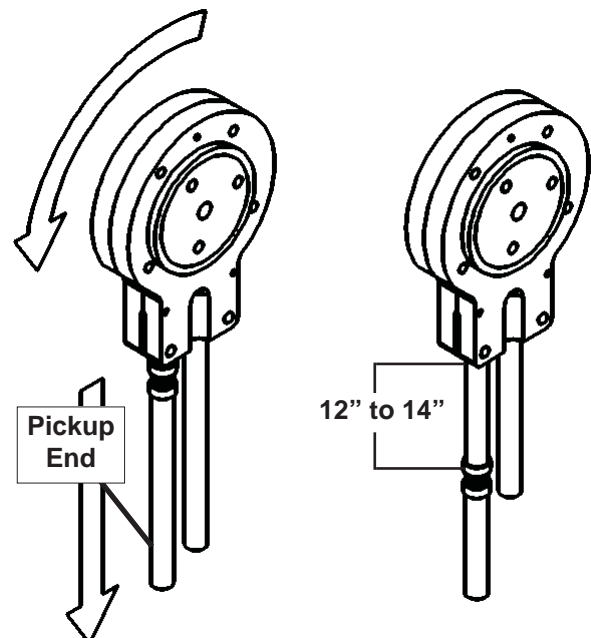

Figure 4-4 Pump Hose Reposition

#### 4.11 MIX PUMP HOSE REPLACEMENT

Mix pump hose must be replaced when tubing cannot be further repositioned (every four to eight weeks). Failure to comply will result in hose failure and possible pump damage. Follow the steps below to replace the hose:

- A. Run cleaning solution through pump.
- B. Turn the pump off and relieve any pressure by opening the spigot.
- C. Disconnect the mix pump hose at each end.
- D. Grasp the discharge hose end with one hand and turn the pump on. Pull down on the hose until all of the remaining hose is removed from the pump. Turn pump off.
- E. Rotate pump roller assembly so one roller is at the 6:00 position.
- F. Use a brush that fits in the opening and clean the pump roller assembly, first with detergent water and then clear water.
- G. Connect the new mix pump hose to the pickup hose adapter using the small clamp.
- H. Feed one end of the mix pump hose into the pickup hose side (left) of the black cover.

#### NOTE

*Feed the tube into the clamp so the natural curve of the tube is towards the outside of the black cover. This prevents the hose from looping around the black cover twice.*

- I. Gently push the hose into the black cover until it begins to feed.
- J. Allow the hose to feed itself through the pump until about 6" (15cm) remains on the entering side.
- K. Turn pump off.
- L. Connect the mix pump hose to the elbow fitting (located on the left side of the mix line manifold) using a small hose clamp. Be careful not to twist the mix hose.
- M. Turn the pump on.
- N. Allow the remaining 6" (15cm) of tubing to feed through the pump until the hose adapter prevents further feeding.
- O. Turn the pump off.

#### CAUTION

##### Risk of Product Damage

Air/Mix Tee must remain below the black cover clamp. If the Tee is above the pump, the mix may drain into the air compressor, resulting in pump damage.

- P. Connect the free end of the mix pump hose to the 3-way Tee. When all connections are complete, the 3-way Tee must be lower than the black pump housing.
- Q. The pump is now ready to sanitize.

#### 4.12 CAB TEMPERATURE ADJUSTMENT

Cab temperature is monitored and controlled by two settings on the IntelliTec control: CabCutIn and CabCtOut. The cut in value determines the temperature at which the refrigeration cycle starts. The cut out setting determines when the cycle stops. To change the CabCutIn or CabCtOut, follow the steps below:

- A. Press and hold SEL button for 8 seconds. While still holding the SEL button, press the up arrow button (↑). The LCD Screen will read "Display".
- B. Release both buttons.
- C. Press the left arrow button (←) three (3) times to navigate to the Storage menu.
- D. Press the up arrow button (↑) once to navigate to the CabCutIn value. Record this value.

#### IMPORTANT:

*Before making changes to any settings, record the original values. If the setting changes do not achieve desired results, return settings to their original values.*

- E. Press SET button to enter edit mode.
- F. Press the up arrow button (↑) to increase the number to the value required. The value increases by 1 each time the up arrow button (↑) is pressed. After the value reaches 9, numbering restarts at 0.
- G. Press SET button to save the setting and exit the edit mode.
- H. Press the up arrow button (↑) once to navigate to the CabCtOut value. Record this value.
- I. Press SET button to enter edit mode.
- J. Press the up arrow button (↑) to increase the number to the value required. The value increases by 1 each time the up arrow button (↑) is pressed. After the value reaches 9, numbering restarts at 0.
- K. Press SET button to save the setting and exit the edit mode.
- L. Press the up arrow (↑) and left arrow (←) buttons to navigate to ExitMenu.
- M. Press the up arrow button (↑) from ExitMenu to return to the Mode Screen.
- N. Locate the Specification Sheet for SU412 Control behind the header panel and record the new values on this sheet.

### 4.13 DRIVE BELT TENSION ADJUSTMENT

To check belt tension, follow the steps below:

- A. Remove a side panel and the back panel.

 <b>WARNING</b>
<b>Hazardous voltage</b>
The Clean/Off/Serve and the Main Freezer Power Off/On switches must be placed in the OFF position when disassembling for servicing. The freezer must be disconnected from electrical supply before removing any access panel. Failure to disconnect power before servicing could result in death or serious injury.

- B. Use a Burroughs Belt Tension Gauge to set the tension for the drive belt. Set the belt tension on the soft serve side to 45-55 lbs. Set the belt tension on the shake side to 35-45 lbs.
- C. If an adjustment is necessary, loosen the four motor plate retaining nuts, adjust belt tension then retighten the four nuts.

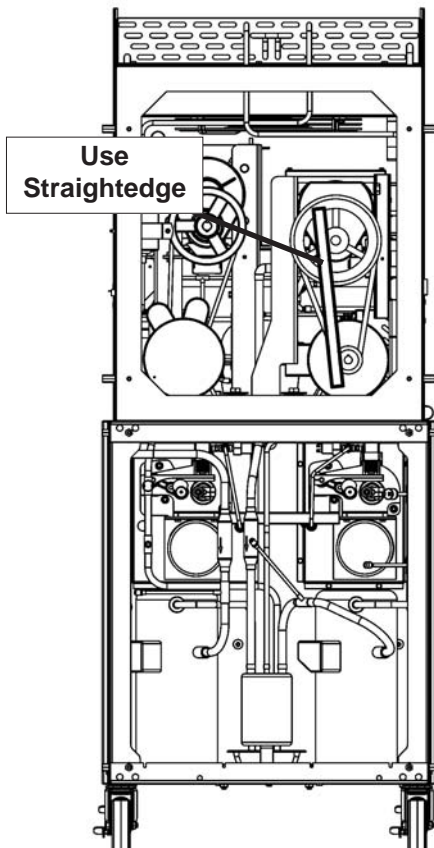

Figure 4-5 Pulley Alignment

- D. Using a straightedge, check that the drive motor pulley is aligned with the speed reducer pulley. Align the pulley if necessary.

#### NOTE

*Belt life will be increased if new drive belts are tightened after two or three weeks of operation.*

### 4.14 CONDENSER CLEANING (AIR-COOLED MACHINES)

The condenser requires periodic cleaning. To clean the condenser, refer to the following steps:

- A. Lift the condenser filter off of the machine cover panel. Visually inspect the condenser filter for dirt.
- B. If the condenser filter is dirty, vacuum or brush it clean. Rinse it with clean water and allow it to dry before replacing it on the machine.
- C. Visually inspect the condenser for dirt by shining a light through the coil of the condenser.
- D. If the condenser is dirty, place a wet towel over the condenser.
- E. Using compressed air or a CO2 tank, blow out the dirt from the inside of the condenser. Most of the dirt will cling to the wet towel.

#### NOTE

*If the condenser is not kept clean, refrigeration efficiency will be lost.*

### 4.15 PREVENTATIVE MAINTENANCE

It is recommended that a preventative maintenance schedule be followed to keep the machine clean and operating properly. The following steps are suggested as a preventative maintenance guide.

The United States Department of Agriculture and the Food and Drug Administration require that lubricants used in food zones be certified for this use. Use lubricants only in accordance with the manufacturer's instructions.

- A. Daily checks
  - Check for any unusual noise or condition and repair immediately.
- B. Monthly checks
  1. Check drive belts for wear and tighten belts if necessary. (Refer to section 4.12)
  2. Check the condenser filter for dirt. (Refer to section 4.13).

#### 4.16 EXTENDED STORAGE

Refer to the following steps for winterizing the machine or for storing the machine over any long period.

- A. Clean all of the parts that come in contact with mix thoroughly with warm detergent . Rinse in clear water and dry all parts. Do not sanitize.

##### NOTE

*Do not let cleaning solution stand in machine barrel or mix pump during the shutdown period.*

- B. Remove, disassemble, and clean the front door, auger shaft, and mix pump. Leave disassembled during the shutdown period.
- C. Place the plastic auger flights in a plastic bag with a moist paper towel. This will prevent the flights from becoming brittle if exposed to dry air over an extended period (over 30 days).
- D. For water-cooled machines that are left in unheated buildings, or buildings subject to freezing, the water must be shut off and disconnected. Disconnect the water inlet fitting. The fitting is located at the rear of the machine. Run the compressor for 2 - 3 minutes to open the water valve (the front door must be attached for the compressor to run). Blow out all the water through the water inlet. Drain the water supply line coming to the machine. Disconnect the water outlet fitting.
- E. Disconnect the machine from the source of the electrical supply in the building.

# SECTION 5 REFRIGERATION SYSTEM

## 5.1 REFRIGERATION SYSTEM

The machine has three separate refrigeration systems; one for each freezing cylinder and one for the cabinet.

The freezing cylinder systems are designed for use with R404A refrigerant and the cabinet system is designed for use with R134A refrigerant. The proper charges are indicated on the information plate.

## 5.2 REFRIGERANT RECOVERY AND EVACUATION

Refer to the following procedures to properly recover and evacuate the refrigeration system. Do not purge refrigerant into the atmosphere.

## NOTE

*For qualified service personnel only. Anybody working with refrigerants must be certified as a Technician TYPE I as required by 40 CFR 82 Subpart F and hold all State and/or local refrigerant handling certifications. In addition, all handling, storage, and disposal of refrigerants must be in accordance with Environmental Protection Agency (EPA) guidelines and standards and all State and local guidelines and standards.*

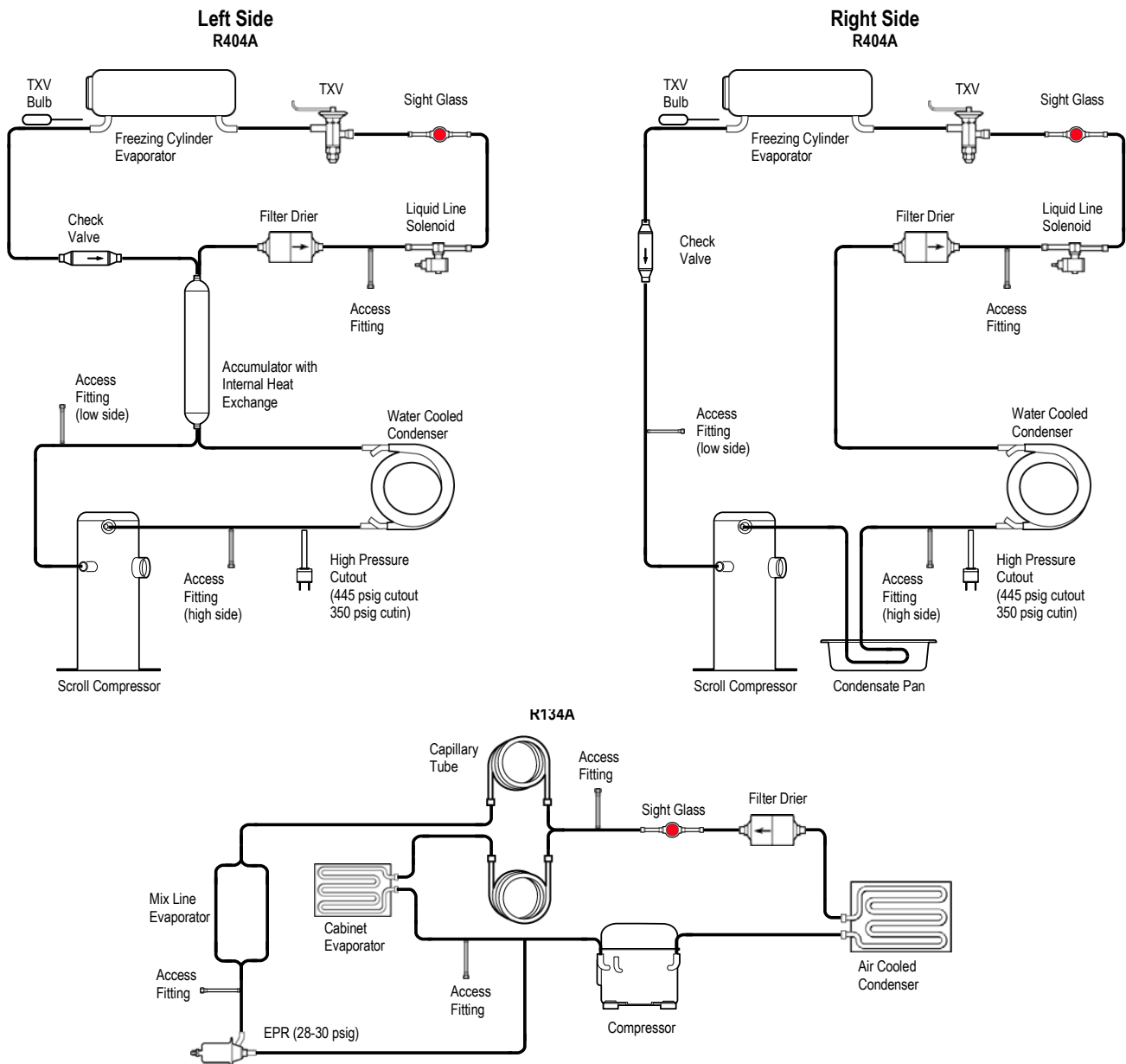

Figure 5-1 Refrigeration System (Water Cooled shown)

## A. REFRIGERANT RECOVERY



### WARNING

#### Hazardous voltage

The Main Freezer Power switch and the Clean/Off/Serve switch must be placed in the OFF position when disassembling for servicing. The machine must be disconnected from electrical supply before removing any access panel. Failure to disconnect power before servicing could result in death or serious injury.

1. Disconnect the machine from electrical supply before removing any panels for servicing.
2. Remove all panels.
3. Connect the recovery unit to the suction and discharge service valves of the compressor.

### CAUTION

The solenoid valve must be energized to allow all refrigerant to be recovered and to prevent injury when brazing.

4. Locate the correct compressor contactor behind the header panel:
  - A. On the left side disconnect the orange wire with black stripe #56 on the contactor coil.
  - B. On the right side disconnect the black wire #82 on the contactor coil.
5. Wrap electrical tape around wire to insulate it.
6. Remove the belt from the pulley to allow the drive motor to spin freely.
7. Connect power to the machine.
8. Energize the solenoid valve:

On the right side, put the Main Freezer Power switch and the Freezing Cylinder OFF/ON switch in the ON position. Press the Push To Freeze button on the IntelliTec control.

On the left side, put the Clean/Off/Serve switch in the Serve position.
10. Operate the recovery unit per manufacturer's instructions

#### NOTE

*If recovery is not completed after 20 minutes on the right side, press the Push To Freeze button again. This will keep the solenoid valves open. The right side solenoid will remain open until the Clean/Off/Serve switch is placed in the Off position.*

## B. EVACUATING THE REFRIGERATION SYSTEM

1. Close any open ports in the refrigeration system.
2. Connect a vacuum gauge to one of the Schrader valves next to an evaporator.
3. Connect the evacuation unit to the suction and discharge service valves of the compressor.
4. Locate the correct compressor contactor behind the header panel:
  - A. On the left side disconnect the orange wire with black stripe #56 on the contactor coil.
  - B. On the right side disconnect the black wire #82 on the contactor coil.
5. Wrap electrical tape around wire to insulate the wire terminals.
6. Remove belts from the pulleys to allow drive motors to spin freely.
7. Connect power to the machine.
8. Energize the solenoid valve:

On the left side, put the Main Freezer Power switch and the Freezing Cylinder OFF/ON switch in the ON position. Press the Push To Freeze button on the IntelliTec control.

On the right side, put the Clean/Off/Serve switch in the Serve position.
10. Evacuate the system until the gauge reads 300 $\mu$  Hg for 5 continuous minutes.

#### NOTE

*If evacuation is not completed after 20 minutes on the right side, press the Push To Freeze button again. This will keep the solenoid valves open. The right side solenoid will remain open until the Clean/Off/Serve switch is placed in the Off position.*

11. If the system will not maintain a standing vacuum for 10 minutes with the vacuum pump off (gauge increases towards atmosphere), find the leak, fix it, and evacuate again.

## 5.3 REFRIGERANT CHARGING

Refer to the following procedures to properly charge the refrigeration system. Stoelting recommends liquid refrigerant charging.

#### NOTE

*For qualified service personnel only. Anybody working with refrigerants must be certified as a Technician TYPE I as required by 40 CFR 82 Subpart F and hold all State and/or local refrigerant handling certifications. In addition, all handling, storage, and disposal of refrigerants must be in accordance with Environmental Protection Agency (EPA) guidelines and standards and all State and local guidelines and standards.*

- A. Ensure the electrical supply has been removed before continuing.
- B. If the system has been opened or if there was a leak, refer to Section 5.2 - Refrigerant Recovery and Evacuation to evacuate the system prior to charging.
- C. Refer to machine's information plate for total charge requirements.

**NOTE**

*The refrigeration systems are critically charged. Be sure to charge the system to the weight listed on the machine's information plate.*

- D. For liquid refrigerant charging, connect refrigerant cylinder to the discharge Schrader valve of the compressor.
- E. Energize the solenoid valve.
- F. Add the proper amount of refrigerant according to the machine's information plate.

**5.4 COMPRESSOR**

The machine has a three compressors: two scroll type compressors (Fig. 5-2) for the freezing cylinders and one reciprocating compressor (Fig. 5-3) for the cabinet. The



**Figure 5-2 Scroll Type Compressor**



**Figure 5-3 Reciprocating Compressor**

scroll compressor type uses two spiral shaped scrolls to compress gas. One scroll rotates around an identical stationary scroll. Gas is drawn into the compression chamber by the rotating scroll and is compressed as it moves towards the center of the chamber. Operation of this compressor is continuous because, during each rotation, several gas 'pockets' are compressed simultaneously.

Details of the compressor's starting components are in Section 6.

**A. WINDING TEST**

To test the scroll compressor motor windings for possible problems, perform the following steps:

- A. Disconnect the machine from electrical supply before removing any panels for servicing.
- B. Remove the rear panel.
- C. Pull the compressor connector plug off of the compressor. The compressor has three terminals; C (common), R (run), and S (start). (Refer to Figure 5-3)

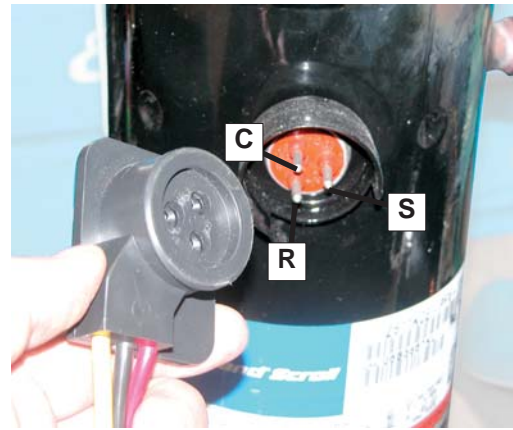

**Figure 5-4 Compressor Connection**

- D. Use an ohmmeter to measure resistance. The measurements should match the table below  $\pm 5\%$ :

Compressor	Electrical	Side	S to C	R to C
282075	3 PH	Shake	1.79Ω	0.00Ω
282083	3 PH	Soft Serve	1.46Ω	0.00Ω
282062	1 PH	Shake	2.28Ω	1.01Ω
282082	1 PH	Soft Serve	2.71Ω	0.91Ω

- E. To check if windings are shorted to ground, connect one ohmmeter lead to a bare metal part on the compressor (such as any copper line leading to or from the compressor) and check terminals C, R, and S.

**NOTE**

*The scroll compressors are equipped with an internal overload protector. If the compressor is warm and ohmmeter readings indicate an open winding, allow up to one hour for overload to reset.*

## B. COMPRESSOR REMOVAL

- A. Disconnect the machine from electrical supply before removing any panels for servicing.

 <b>WARNING</b>
<b>Hazardous voltage</b> The Main Freezer Power switch and the Clean/Off/Serve switch must be placed in the OFF position when disassembling for servicing. The machine must be disconnected from electrical supply before removing any access panel. Failure to disconnect power before servicing could result in death or serious injury.

- B. Disconnect the electrical plug from the compressor.
- C. Recover refrigerant charge per the instructions in Section 5.2.
- D. Leave the suction and discharge ports open to prevent pressure buildup during compressor removal.
- E. Remove six inches of insulating tubing on the suction line going to the compressor and unsweat the suction and discharge line from the compressor.
- F. Remove the four nuts and washers from the base of the compressor.
- G. Remove the compressor through the back of the machine.
- H. Remove the four rubber compressor mounts from the compressor.
- I. Crimp and braze all open ports of the old compressor.

### NOTE

*A compressor returned to Stoelting with any open ports will void the warranty. ALWAYS crimp and braze ports on a compressor that has been removed.*

## C. COMPRESSOR INSTALLATION

- A. Disconnect the machine from electrical supply before removing any panels for servicing.
- B. Install the four rubber mounts on the compressor.
- C. Install the compressor into the machine, fitting the base over the four bolt holes.
- D. Install the four washers and nuts onto the bolts and tighten securely.
- E. Remove all tubing plugs from the replacement compressor.

## NOTE

*The compressor plugs protect the compressor from moisture in the air. Do not remove the plugs until you are ready to install. The compressor must not be opened to the atmosphere for more than 10 minutes.*

- F. Leave the suction and discharge ports open to prevent pressure buildup. Braze the suction and discharge line to the compressor.
- G. Connect the electrical plug to the compressor. The plug is keyed and will only install one way. (Refer to Figure 5-3)
- H. Replace the drier per the instructions in Section 5.9.
- I. Evacuate the system per the instructions in Section 5.2
- J. Recharge the system per the instructions in Section 5.3.
- K. Replace the insulating tubing on the suction line.

## 5.5 CONDENSER

The SU444 is available with a water-cooled or an air-cooled condenser. The capacity of the machine is directly related to keeping the condenser clean and free of debris.

The water-cooled condenser is a tube and shell type. This condenser requires cool, clean water to function properly. Inlet and discharge lines must be 3/8" ID minimum.

The air-cooled condenser is a copper tube and aluminum fin type. The machine must have a minimum of 3" of clearance on the sides and back for proper air flow.

### CONDENSER TESTING

The condenser can be checked for leaks using the bubble test or using a leak detector.

## 5.6 EVAPORATOR

The machine has two freezing cylinder evaporators and a cab evaporator.

### EVAPORATOR TESTING

The evaporators can be checked for leaks using the bubble test or using a leak detector.

## NOTE

*Foam insulation in the evaporator will set off electronic leak detectors if disturbed.*

## 5.7 VALVES

### A. THERMOSTATIC EXPANSION VALVE (TXV)

The Thermostatic Expansion Valve (TXV) is used to meter the refrigerant to the freezing cylinder evaporator. The self-regulating TXV is preset by the manufacturer and adjustment is not recommended. Figure 5-4.

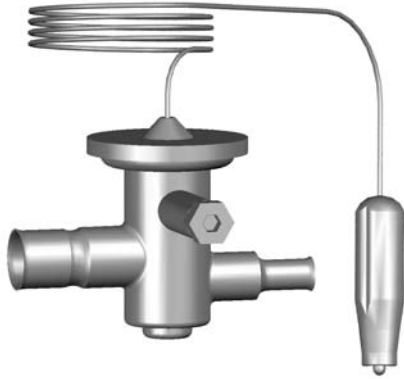

Figure 5-5 TXV

### TXV TESTING & ADJUSTMENT

When testing a TXV, run only the side that the TXV meters.

#### NOTE

*The bulb has an indent which must be positioned against the tubing. Good contact between the bulb and the suction line is necessary for proper operation of the valve. The bulb must also be well insulated.*

- A. Connect a gauge to the Schrader valve on the suction line next to the evaporator.
- B. Connect a thermocouple to the suction line next to the evaporator.
- C. Immediately before the refrigeration cycle ends, the gauge should read between 21-23 psig. The superheat on the left side should be 4-6°F. The superheat on the right side should be 10-16°F.
- D. If the pressure reading is higher than expected and the superheat is low, check to see if there is an overcharge of refrigerant.
- E. If the pressure reading is lower than expected and the superheat is high, check to see if there is a low refrigerant charge or if there is a restriction in the system.

#### NOTE

*The TXV is the LAST component to adjust in the refrigeration system.*

- F. The TXV can be adjusted after the steps above are completed. When adjusting, do not turn the valve over 1/4 turn (90°). Turn the valve stem clockwise to increase the superheat or counterclockwise to decrease the superheat.

### TXV REMOVAL

- A. Remove the side panel.
- B. Remove bulb from suction line exiting from the evaporator.
- C. Recover refrigerant charge per instructions in Section 5.2.
- D. Leave the suction and discharge ports open to prevent pressure buildup during TXV removal.
- E. Remove any insulation from the TXV and immediate surrounding lines.
- F. Apply a heat sink (wet cloth) to the valve dome (Figure 5-5).
- G. Unsweat the TXV and remove.

### TXV REPLACEMENT

To replace the TXV, perform the following procedures:

- A. Position the TXV with a heat sink into the system.
- B. With the suction and discharge ports open, braze the TXV into the system using appropriate brazing material.
- C. Remove the heat sink from the TXV.
- D. Install bulb on suction line exiting the evaporator using existing clamp. The bulb has an indent which must be placed against the tubing.

#### NOTE

*Good contact between the bulb and the suction line is necessary for proper operation of the valve. The bulb must also be well insulated.*

- E. Tighten clamp to 20 in/lb using a torque wrench.
- F. Replace insulation to the TXV and surrounding lines.
- G. Replace the drier per the instructions in Section 5.9.
- H. Evacuate the system per the instructions in Section 5.2.
- I. Recharge the system per the instructions in Section 5.3.

## B. CHECK VALVE

The machine has 2 magnetic check valves (Refer to Figure 5-6). Each valve is positioned in the suction line and prevents backflow of refrigerant into the evaporator. If there is reversed flow, the product in the freezing cylinder softens and liquid refrigerant can flood into the compressor on startup.

If a check valve needs to be replaced, use a heat sink (wet cloth) when installing the new valve to prevent damage.



Figure 5-6 Check Valve

## C. HIGH PRESSURE CUTOUT

The high pressure cutout stops the compressor if the discharge pressure reaches 445 psig.

### HIGH PRESSURE CUTOUT TEST

- A. Connect a gauge to the Schrader valve on the discharge line.
- B. Disconnect cooling:  
Air-Cooled - Disconnect evaporator fan  
Water-Cooled - Shut off water supply
- C. High pressure cutout should trip when pressure reaches 445 psig  $\pm 9$ .

### HIGH PRESSURE CUTOUT REMOVAL

- A. Remove the back panel.
- B. Recover refrigerant charge per instructions in Section 5.2.
- C. Leave the suction and discharge ports open to prevent pressure buildup during removal.
- D. Unsweat high pressure cutout from discharge line.
- E. Disconnect the wires from high pressure cutout.

### HIGH PRESSURE CUTOUT REPLACEMENT

- A. With the suction and discharge ports open, braze the high pressure cutout to the discharge line.
- C. Replace the drier per the instructions in Section 5.9.
- D. Braze the high pressure cutout to the discharge line.

- E. Evacuate the system per the instructions in Section 5.2.
- F. Recharge the system per the instructions in Section 5.3.
- G. Connect the wires to the high pressure cutout.

## D. WATER VALVE (WATER COOLED MODELS ONLY)

The water valve monitors refrigerant pressure and opens on an increase of pressure. The opening point pressure is the refrigerant pressure required to lift the valve disc off the valve seat. (Figure 5-12)



Figure 5-7 Water Valve

### WATER VALVE ADJUSTMENT

- A. Remove the back panel.
- B. Connect a gauge to the compressor discharge Schrader valve.
- C. Connect the machine to the electrical supply, start the refrigeration cycle, and read the pressure.
- D. The proper gauge reading should be 175-180 psig. The exit water temperature should be 95-107°F.
- E. If the water temperature and high side pressure are too low, the opening point pressure should be increased to slow the water flow. Turn the adjustment screw counterclockwise.
- F. If the water temperature and high side pressure are too high, the opening point pressure should be decreased to increase the flow of water. Turn the adjustment screw clockwise.

### WATER VALVE REMOVAL

The water valve is connected to the refrigeration system by capillary tube brazed to the discharge line.

- A. Turn off and disconnect the water supply. Blow out the water lines with compressed air or CO<sub>2</sub>.
- B. Recover refrigerant charge per instructions in Section 5.2.
- C. Leave the suction and discharge ports open to prevent pressure buildup during water valve removal.

- D. Unsweat the capillary tube from the discharge line.
- E. Remove the clamps from the water lines at the valve.
- F. Remove the two screws holding the water valve to the frame and remove the valve.

### WATER VALVE REPLACEMENT

To replace the water valve, perform the following procedures:

- A. Position the water valve and attach to the frame using the two screws.
- B. Install the water lines onto the valve with hose clamps.
- C. Leave the suction and discharge ports open to prevent pressure buildup during water valve installation.
- D. Braze the capillary tube into the system using appropriate brazing material.
- E. Connect the water supply line and turn on the water supply.
- F. Check for leaks in the water lines. If there are no leaks, turn off the water supply.
- G. Replace the filter drier. Refer to Section 5.8 for details.
- H. Evacuate and recharge system per instructions in Section 5.2.
- I. Turn on the water and check for leaks in the water lines with the refrigeration system running.
- J. Adjust the valve as necessary.

### 5.8 SOLENOID

The solenoid valves are installed on the liquid lines of the freezing cylinder evaporator (Refer to Figure 5-13). A solenoid valve has a magnetic coil that, when energized, lifts a plunger and allows refrigerant to flow.

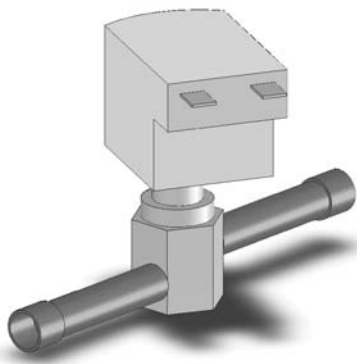

**Figure 5-8 Solenoid Valve**

### ACTIVATING A SOLENOID VALVE

- A. Disconnect the machine from electrical supply before removing any panels for servicing.



#### WARNING

#### Hazardous voltage

The Main Freezer Power switch and the Clean/Off/Serve switch must be placed in the OFF position when disassembling for servicing. The machine must be disconnected from electrical supply before removing any access panel. Failure to disconnect power before servicing could result in death or serious injury.

- B.. Remove the side panels
- C. Locate the correct compressor contactor behind the header panel:
  - A. On the left side disconnect the orange wire with black stripe #56 on the contactor coil.
  - B. On the right side disconnect the black wire #82 on the contactor coil.
- D. Wrap electrical tape around wire to insulate the wire terminals.
- E. Remove the belt from the pulley to allow the drive motor to spin freely.
- F. Connect power to the machine.
- G. Energize the solenoid valve:
  - On the right side, put the Main Freezer Power switch and the Freezing Cylinder OFF/ON switch in the ON position. Press the Push To Freeze button on the IntelliTec control.
  - On the left side, put the Clean/Off/Serve switch in the Serve position.

### SOLENOID TESTING

When activated, a solenoid coil produces a magnetic field. This field can be detected by placing the tip of a metal screwdriver close to the retaining screw on the solenoid coil. The retaining screw will act like a magnet and pull on the screwdriver tip. Additionally, the solenoid will make a clicking sound when activated.

To test the solenoid, follow the steps below:

- A. Energize the solenoid valve:
- B. On the left side, put the Main Freezer Power switch and the Freezing Cylinder OFF/ON switch in the ON position. Press the Push To Freeze button on the IntelliTec control.
- C. On the right side, put the Clean/Off/Serve switch in the Serve position.
- D. Measure voltage at the solenoid terminals. The solenoid for the left side should read 24VAC. The solenoid for the right side should read 115VAC.

- E. Attach a gauge to the access fitting before the solenoid and monitor refrigerant pressure. Excessively high pressure indicates a malfunctioning solenoid.
- F. Disconnect the machine from the electrical supply.
- G. Disconnect the wires from the solenoid.
- H. Check for a short or an open at the solenoid terminals. To check for a short, measure resistance from each terminal to the copper refrigeration tubing. If the resistance is zero, then there is a short in the solenoid coil. To check for an open, measure resistance between the coil terminals.

#### SOLENOID MAGNETIC COIL REMOVAL

- A. Remove the side panel.
- B. Disconnect the electrical wires.
- C. Remove the retaining screw from the top of the solenoid and pull the magnetic coil off.

#### SOLENOID MAGNETIC COIL INSTALLATION

To replace the magnetic coil, perform the following procedures:

- A. Connect the two electrical wires to the magnetic coil.
- B. Push the coil on to the solenoid valve stem.
- C. Make sure there isn't any foam insulation between the valve coil and valve body. Trim any excess insulation.
- D. Install the retaining screw onto top of coil.

#### SOLENOID VALVE REMOVAL

- A. Recover refrigerant charge per instructions in Section 5.2.
- B. Remove insulation around valve and attached refrigeration lines.
- C. Apply heat sinks (wet cloth) to the insulated refrigerant lines near the valve.
- D. Leave a port open to prevent pressure buildup during solenoid removal.
- E. Identify and disconnect the two wires from the solenoid coil.
- F. Remove the retainer holding the coil to the solenoid body and remove the coil.
- G. Unsweat the solenoid and remove.

#### SOLENOID VALVE REPLACEMENT

To replace the solenoid, perform the following procedures:

- A. Position the new solenoid with the arrow pointing toward the direction of flow.
- B. Apply a heat sink (wet cloth) to the solenoid valve.
- C. With the suction and discharge ports open, braze the solenoid into the system using appropriate brazing material.
- D. Remove the heat sink from the valve.

- E. Replace insulation around valve.
- F. Replace the filter drier. Refer to Section 5.8 for details.
- G. Evacuate and recharge system per instructions in Section 5.2.

#### 5.9 FILTER DRIER

The filter drier must be replaced every time the refrigeration system is opened for service. A new filter drier improves operation of the entire refrigeration system by stopping the circulation of moisture and by removing harmful contaminants (Refer to Figure 5-14).

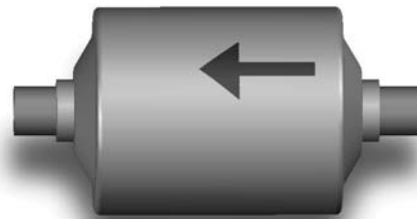

Figure 5-9 Filter Drier

#### FILTER DRIER REMOVAL

- A. Recover refrigerant charge per instructions in Section 5.2.
- B. Cut the refrigeration line as close to the filter drier as possible and remove drier.

#### NOTE

*The refrigeration line must be cut. Do not unsweat the filter drier.*

#### FILTER DRIER REPLACEMENT

- A. Position the filter drier so the arrow is pointing towards the evaporators (pointing away from the condenser).
- B. Apply a heat sink (wet cloth) to the filter drier.
- C. With the suction and discharge ports open, braze the filter drier into the system using appropriate brazing material.
- D. Evacuate the system per instructions in Section 5.2.
- E. Recharge the system per instructions in Section 5.3.

## 5.10 CAPILLARY TUBE

There are two capillary tubes. The capillary tubes meter refrigerant flow in the cabinet evaporator and the mix line evaporator (Refer to Figure 5-15). The amount of flow is dependent on the length and ID of the capillary tube as well as the refrigerant charge.



Figure 5-10 Capillary Tube

### CAPILLARY TUBE REMOVAL

- A. Recover refrigerant charge per instructions in Section 5.2.
- B. Leave a port open to prevent pressure buildup during capillary tube removal.
- C. Remove foam insulation from the capillary tube at the evaporator inlet.
- D. Unsweat the capillary tube and remove.

### CAPILLARY TUBE REPLACEMENT

- A. Position the capillary tube in the refrigeration system.
- B. Apply a heat sink (wet cloth) to the capillary tube.
- C. With the suction and discharge ports open, braze the capillary tube into the system using appropriate brazing material.
- D. Replace foam insulation to the capillary tube at the evaporator inlet.
- E. Evacuate the system per instructions in Section 5.2.
- F. Recharge the system per instructions in Section 5.3.

## 5.11 ACCUMULATOR

The accumulator is located on the suction line of the left side. It protects the compressor by storing any liquid refrigerant that wasn't boiled off in the evaporator.

An internal heat exchanger helps to boil off any liquid refrigerant in the accumulator.

### NOTE

*If the accumulator needs to be replaced, make sure to braze the suction line (from the evaporator) to the inlet of the accumulator.*



Figure 5-11 Accumulator

## 5.12 CAB UNIT

The IntelliTec control is programmed to handle refrigeration of the cabinet independently from the freezing cylinder. The control maintains cabinet temperature between two preset values (CabCutIn and CabCtOut). If the cabinet door is opened during a refrigeration cycle, the evaporator fan will continue to run but the refrigeration cycle will be interrupted to prevent the evaporator coils from icing up.

The refrigeration will run for a maximum of 4 minutes. After this time is reached, the refrigeration cycle will stop for a minimum of 3 minutes. At the expiration of 3 minutes, the control will check cabinet temperature. If product temperature is at or above CabCutIn, a refrigeration cycle will start.

To adjust temperature, refer to Section 4-4 Obtaining Readings and Modifying Settings.



## SECTION 6 ELECTRICAL AND MECHANICAL CONTROL SYSTEMS

### NOTE

*The wiring diagram is available in Section 8.*

### 6.1 CONTROLS

#### A. INTELLITEC CONTROL

The IntelliTec control operates the shake side and the cabinet of the machine.

The IntelliTec control consists of three main components; the control board (Figure 6-1), the membrane switch (Figure 6-2), and the display panel module (Figure 6-3). The membrane switch is connected to the display panel module via a 9-pin ribbon cable. The display panel module is connected to the IntelliTec control board through a telephone cord. The IntelliTec control board is connected to the machine through an 8-pin connector, a 7-pin connector, and a 6-pin connector.

#### B. CHALLENGER CONTROL

The Challenger control operates the soft serve side of the machine. It consists of a control board and is connected to the machine through eight terminals.

### 6.2 CONTACTORS

The contactors are located behind the header panel. There are two drive motor contactors and two compressor contactors (one for each side). There is also a contactor for the cabinet and a contactor for the condenser on air cooled machines.

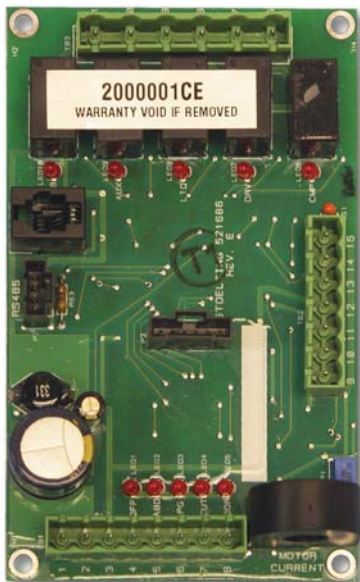

**Figure 6-1 IntelliTec Control Board**

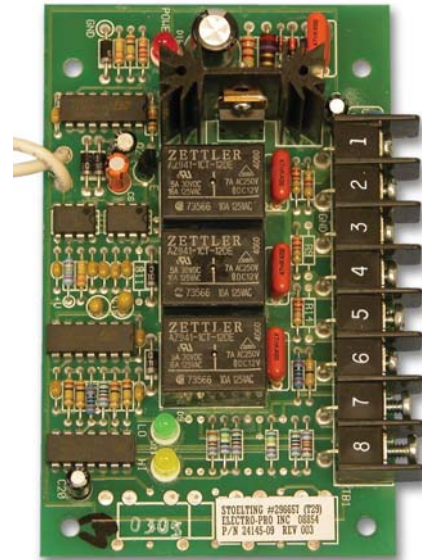

**Figure 6-2 Challenger Control Board**

The control boards send electronic signals to trigger the contactors. The signals to the contactors are staggered, so the drive motor will always start and stop three seconds before the compressor. By staggering the starting and stopping of the drive motor, maximum starting torque is available and voltage spikes are reduced.

#### A. CONTACTOR TESTS

The following tests will show if a contactor is working properly.

1. Open header panel.
2. Check the control board:

On the soft serve side (left), check for a signal going to the contactor. To check for a signal to the drive motor contactor, take voltage readings at the 2 and 3 terminals on the control board. To check for a signal to the compressor contactor, take voltage readings at the 2 and 4 terminals on the control board. The voltage should be about 24VAC.

On the shake side (right), visually check the IntelliTec control board. When the spigot is opened or the Push To Freeze button is pressed, the DRV LED on the control board will light up. After three seconds, the CMP LED will light up. If the LEDs do not light up, refer to Section 7 Troubleshooting. Take voltage readings at the at pin 16 and pin 17 on the control board. The voltage should be about 115VAC.

### NOTE

*In addition to the LEDs lighting, there will be an audible click from the contactors and the motor and compressor will start.*

3. Check to ensure contactor is receiving signal. Read voltage across the coils of the contactor during a freezing cycle. Voltage should be about 24VAC for the left side and about 115VAC for the right side. If there is no voltage reading, refer to Section 7 Troubleshooting.

### 6.3 DRIVE MOTOR

The drive motors are used to rotate the auger assemblies.

#### A. DRIVE MOTOR TEST

1. Make sure the machine is off. On the shake side, put the Main Freezer Power switch and the Freezing Cylinder OFF/ON switch in the OFF position. On the soft serve side, put the Clean/Off/Serve switch in the Off position.
2. Remove the back panel and a side panel.
3. Loosen the belt tension adjustment nut and remove the belt.
9. Start the drive motor.
10. Put a clamp ammeter on the motor wire at T1 of the motor contactor. The soft serve motor should read 4.1 amps  $\pm 1$  and the shake motor should read 2.1 amps  $\pm 0.5$ .

#### NOTE

*The motor amps are based on 230VAC supply voltage.*

11. Stop the drive motor. On the shake side, put the Main Freezer Power switch and the Freezing Cylinder OFF/ON switch in the OFF position. On the soft serve side, put the Clean/Off/Serve switch in the Off position.
12. Install the belt and tighten the tension bolt.
13. Use a Burroughs Belt Tension Gauge to set the tension for the drive belt. Set the belt tension on the soft serve side to 45-55 lbs. Set the belt tension on the shake side to 35-45 lbs.
14. Using a straightedge, align the drive motor pulley with the gearbox pulley. Tighten the two allen head screws.

#### B. DRIVE MOTOR REMOVAL

1. Disconnect machine from electrical supply before removing any panels for servicing.
2. Remove the back panel and a side panel.
3. Remove the electrical cover plate from the motor.
4. Identify (mark) wires and remove them from the motor.
5. Loosen the belt tension adjustment nut and remove the belt.



#### WARNING

##### Hazardous voltage

The Main Freezer Power switch and the Clean/Off/Serve switch must be placed in the OFF position when disassembling for servicing. The machine must be disconnected from electrical supply before removing any access panel. Failure to disconnect power before servicing could result in death or serious injury.

6. Remove the motor mounting bolts.
7. Loosen the two allen head screws from the pulley.
8. Remove the pulley and key from the motor shaft.

#### C. DRIVE MOTOR INSTALLATION

1. Place the drive motor in position and install the four mounting bolts.
2. Place the pulley and key on the motor shaft.

#### NOTE

*Do not tighten the pulley screws until after the belt tension has been properly adjusted.*

3. Install the belt and tighten the tension bolt.
4. Use a Burroughs Belt Tension Gauge to set the tension for the drive belt. Set the belt tension on the soft serve side to 45-55 lbs. Set the belt tension on the shake side to 35-45 lbs.
5. Using a straightedge, align the drive motor pulley with the gearbox pulley. Tighten the two allen head screws.
6. Install wiring according to wiring diagram (located behind header panel). Install electrical cover plate.
7. Install back and side panels.

## 6.4 CAPACITORS

The compressor start and run capacitors are mounted behind the side panels on 1 phase machines. The start and run capacitors for the drive motors are mounted directly onto the motor body.

### A. CAPACITOR TEST

1. Disconnect machine from electrical supply before removing any panels for servicing.

 <b>WARNING</b>
<b>Hazardous voltage</b> The Main Freezer Power switch and the Clean/Off/ Serve switch must be placed in the OFF position when disassembling for servicing. The machine must be disconnected from electrical supply before removing any access panel. Failure to disconnect power before servicing could result in death or serious injury.

2. Remove a lead from one of the capacitor terminals.
3. Using insulated pliers, discharge the capacitor by connecting a 20K Ohm 5W resistor across the terminals.

#### NOTE

*Discharge the capacitor even if there is a bleeder resistor across the terminals. There may be an open in the bleeder resistor preventing it from working properly.*

4. Disconnect the bleeder resistor from the circuit.
5. Check the capacitance across the terminals. Refer to the table below for the correct readings..

### B. CAPACITOR REPLACEMENT

1. Disconnect machine from electrical supply before removing any panels for servicing.
2. Remove leads from the capacitor terminals.

3. Using insulated pliers, discharge the capacitor by connecting a 20K Ohm 5W resistor across the terminals.

#### NOTE

*Discharge the capacitor even if there is a bleeder resistor across the terminals. There may be an open in the bleeder resistor preventing it from working properly.*

4. Pull the capacitor out of its holder and replace.
5. Connect the leads to the terminals.

## 6.5 GEARBOX

### A. GEARBOX INSPECTION

Inspect the gearbox for traces of leaking lubricant and listen for unusual noise. A grinding sound generally indicates a bad gear.

### B. GEARBOX REMOVAL

1. Disconnect machine from electrical supply before removing any panels for servicing.
2. Remove the back panel and a side panel.
3. Remove the belts.
4. Remove the pulley by loosening the set screws.
5. Place a 2"x4" piece of wood to support the evaporator.
6. Remove the evaporator supports and gearbox.  
 On the left side (soft serve), remove the bolts holding the evaporator support to the gearbox. Then remove the bolts holding the gearbox to the back of the evaporator.  
 On the right side (shake), remove the bolts holding the evaporator support and gearbox to the back of the evaporator.

### C. GEARBOX INSTALLATION

1. Place the gear box in position from the rear of the machine.

Capacitor	Part	Rating	
		MFD	VAC
Compressors - Start (Shake and Soft Serve)	230638	88-106 MFD	330 VAC
Compressor - Run (Soft Serve)	231047	45 MFD	370 VAC
Compressor - Run (Shake)	230653	40 MFD	370 VAC
Motor - Start (Soft Serve)	230622	200 MFD	250 VAC
Motor - Run (Soft Serve)	231075	30 MFD	370 VAC
Motor - Start (Shake)	231095	500 MFD	125 VAC
Motor - Run (Shake)	231096	50 MFD	240 VAC
Fan Motor	230654	5 MFD	400 VAC

Figure 6-3 Capacitance Table

2. Install the gearbox and evaporator supports to the evaporator.

On the left side (soft serve), fasten the bolts through the gearbox to the rear of the evaporator. Then fasten the bolts holding the evaporator support to the gearbox.

On the right side (shake), fasten the bolts through the evaporator support and gearbox to the back of the evaporator.

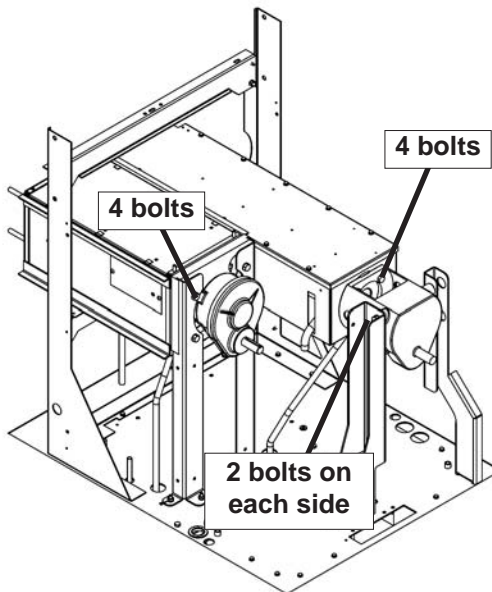

**Figure 6-4 Gearbox Replacement**

3. Mount the pulley on the gear box shaft and align with the motor pulley, then tighten the allen head screws.
4. Install the belt.
5. Use a Burroughs Belt Tension Gauge to set the tension for the drive belt. Set the belt tension on the soft serve side to 45-55 lbs. Set the belt tension on the shake side to 35-45 lbs.
6. If an adjustment is necessary, loosen the four motor plate retaining nuts, adjust belt tension then retighten the four nuts.

## 6.6 CONDENSER FAN MOTOR (AIR-COOLED ONLY)

The fan motor requires the buck-boost transformer to be connected if supply voltage is lower than 215VAC.

### A. CHECK VOLTAGE

1. With the machine connected to power and the Main Freezer Power switch ON, press and hold the SEL button for at least 8 seconds. While still holding SEL, press the left arrow (←) button, and then release both buttons. The display will read "Display".

2. Press the up arrow (↑) button to navigate to the Supply V screen.

### NOTE

*The buck-boost transformer is only for the fan motor.*

3. If the voltage is 215VAC or less, then the buck-boost transformer needs to be connected. Refer to the "Air Cooled Only" inset of the wiring diagram.
4. If the voltage is above 215VAC, then the buck-boost transformer should not be connected.

### NOTE

*The voltage reading must be taken to ensure the fan motor works properly.*

### B. FAN MOTOR REPLACEMENT

1. Disconnect machine from electrical supply before removing any panels for servicing.
2. Remove a side panel and the header panel.
3. Trace and disconnect the brown and blue wires on the fan motor.
4. Remove the torx screws from the fan guard.
5. Remove the bolts holding the fan guard to the condenser shroud.
6. Remove the fan guard and the fan motor assembly.

### C. FAN MOTOR INSTALLATION

1. Move the fan into place.
2. Insert the fan motor wires through the hole in the fan guard and move the fan guard into place.
3. Install the fan guard to the shroud with the four bolts.
4. Rotate the fan motor so the wires are towards the front of the machine. This will line up the holes to attach the fan to the fan guard.
5. Install the fan to the fan guard using the torx screws.
6. Wire the fan motor according to the wiring diagram. The buck-boost transformer must be connected if necessary (see above regarding checking voltage).

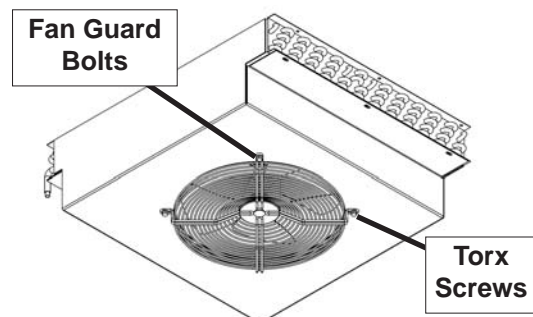

**Figure 6-5 Condenser Fan**

## 6.7 CAB CONDENSER FAN MOTOR

### A. FAN MOTOR REPLACEMENT

1. Shut the machine down and remove mix from the freezing barrel and cab.
2. Disconnect machine from electrical supply.



#### WARNING

##### Hazardous voltage

The Main Freezer Power switch and the Clean/Off/Serve switch must be placed in the OFF position when disassembling for servicing. The machine must be disconnected from electrical supply before removing any access panel. Failure to disconnect power before servicing could result in death or serious injury.

3. Remove the mix containers and sliding drawer from the cab.
4. Disconnect the tubing from the mix transfer line and the air line at the top of the cab.
5. Remove the bolts holding the evaporator shroud to the cabinet. There are four bolts towards the back of the cabinet and three bolts at the front.

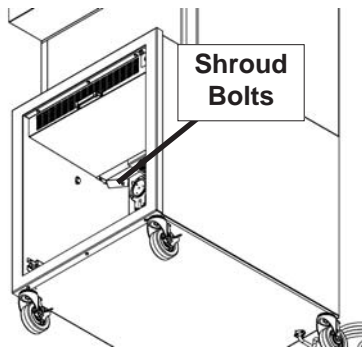

Figure 6-6 Cabinet Evaporator Shroud

6. Remove the two fan bracket screws and disconnect wires on the fan motor.
7. Remove the metal ring and remove the fan blade from the fan motor.
8. Remove the bolts holding the fan motor to the bracket.
9. Install the fan motor to the bracket and install the fan blade onto the motor.
10. Connect the wiring on the new fan motor using the wiring diagram.
11. Install the fan motor bracket into the cabinet.
12. Install the evaporator shroud into the cabinet.
13. Install all tubes and replace sliding drawer and mix containers.

## 6.8 SWITCHES

### A. SPIGOT SWITCH

The spigot switch is a normally closed switch held open by the spigot handle. When a spigot is pulled, the spigot switch sends a signal to the control.

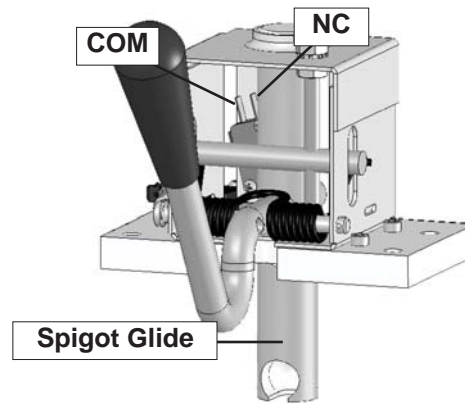

Figure 6-7 Spigot Cam Assembly

### SPIGOT SWITCH TEST - ADJUSTMENT

#### NOTE

*Adjustments to the spigot switch should be done after the product is at consistency in "Serve Mode" or when the machine is empty.*

1. Open the spigot slowly and listen for a click when the spigot switch closes.
2. The clicking sound should be within the first 1/2" of the spigot glide movement (Refer to Figure 6-7). If the switch does not close, an adjustment may be necessary.

### SPIGOT SWITCH TESTING - ELECTRICAL

1. Disconnect the switch from the circuit by unplugging the connectors.
2. Check resistance readings across the common (COM) and normally closed (NC) terminals. When the spigot is closed, the resistance should show an open. When the spigot is opened, the switch will close and the resistance should be 0 ohms.

### SPIGOT SWITCH ADJUSTMENT

1. Place the the Clean/Off/Serve switch (left side) and Freezing Cylinder Off/On switch (right side) in the OFF position.
2. Remove the header panel.
3. Loosen the bolts on the spigot switch.
4. Using a pencil, mark the spigot glide 1/4" from the spigot housing.
5. Adjust the switch to activate when the plastic glide reaches the mark.
6. Fully tighten the retaining bolts and remove mark from spigot glide.

## SPIGOT SWITCH REPLACEMENT

1. Remove the header panel.
2. Remove the dispense rate adjuster knob located below the header panel. (Refer to Figure 6-9)
3. Remove the two Phillips head screws that attach the spigot cam assembly to the panel. Remove the assembly.
4. Disconnect the connector from the switch and remove the switch.
5. Install the replacement switch onto the handle assembly. Do not fully tighten the retaining screws at this time.
6. Using a pencil, mark the spigot glide 1/4" from the spigot housing. Adjust the switch to activate when the spigot handle moves the glide to the mark.
7. Fully tighten the retaining screws.
8. Attach the connector to the spigot switch.
9. Position the spigot handle assembly in the electrical box and fasten securely with the two Phillips head screws.
10. Replace the dispense rate adjuster knob and tighten.
11. Replace the header panel and secure with the two Phillips head screws.

## B. BLENDER ACTIVATION SWITCH (SU444 SHAKE)

The blender switch for the shake side is a normally closed switch. When the shake spigot is pulled to the right, the

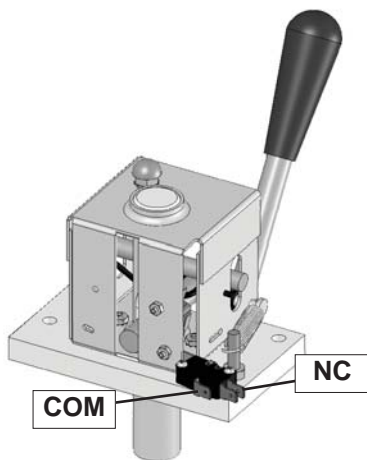

Figure 6-8 Blender Activation Switch

switch closes the circuit and starts the blender.

## SWITCH TESTING - ELECTRICAL

1. Disconnect the switch from the circuit by unplugging the terminals.

2. Check resistance readings across the common (COM) and normally closed (NC) terminals. When the spigot is closed, the resistance should show an open. When the spigot is opened, the switch will close and the resistance should be 0 ohms.

## SWITCH REPLACEMENT

1. Remove the header panel.
2. Disconnect the terminals from the switch and remove the switch.
3. Install the replacement switch onto the assembly

## C. PUMP PRESSURE SWITCH

The pump pressure switch maintains constant pressure in the mix line.

## PUMP PRESSURE SWITCH TEST

1. Turn off the pump motor.
2. Open the spigot to relieve air pressure in the system.
3. Connect a gauge between the 1/4" ID tubing and the air line into the cab. The air line is at the rear of the cab.
4. Turn on the pump motor and watch the gauge:  
The left side motor should cutout at 24 psig  $\pm$ 2  
The right side motor should cutout at 15 psig  $\pm$ 2
6. Open the spigot and watch the gauge.  
The left side motor should cutin at 18 psig  $\pm$ 2  
The right side motor should cutin at 9 psig  $\pm$ 2

## D. CAB DOOR MAGNETIC REED SWITCH

The cab door magnetic reed switch is a normally closed held open switch. When the cab door is opened, the switch sends a signal to the control to stop refrigeration to the cabinet. This prevents the evaporator from icing up.

## REED SWITCH TEST

1. Place the the Clean/Off/Serve switch (left side) and Freezing Cylinder Off/On switch (right side) in the OFF position.
2. Refer to the wiring diagram and remove the wires at terminals 5 and 9 of the right side control board.
3. Check resistance readings across the wires. When the cab door is closed, the resistance should show an open. When the cab door is opened, the resistance should be 0 ohms.
4. Reconnect the wires to the control board.

## REED SWITCH REPLACEMENT

1. Place the Main Power OFF/ON switch and both Freezing Cylinder OFF/ON switches in the OFF position.
2. Refer to the wiring diagram and remove the wires at terminals 5 and 9 of the right side control board.

3. Remove the switch bracket and unscrew the switch from the bracket.
4. Remove the old switch from the machine.
5. Route the wires of the new switch through the machine to the control board.
7. Install the new switch into the bracket. Hand tighten the nuts on the switch so that the switch sticks out of the bracket 1/4".

**NOTE**

*Make sure the switch protrudes from the bracket by 1/4" so that the door will properly seal and the magnet will make contact with the switch.*

8. Install the switch bracket to the machine.
9. Test the switch to ensure it makes contact with the door magnet and ensure the door closes and seals properly.
6. Refer to the wiring diagram and connect the wires to the control board.

**6.9 TEMPERATURE CONTROL SENSOR**

The temperature control sensor is a thermistor used to sense the temperature of the suction line. As the suction line temperature increases, the internal resistance of the thermistor will decrease. Figures 6-9 and 6-10 show the relationship between sensor resistance and temperature.

The freezing cylinder sensors are located on the suction line adjacent to the TXV bulb. The cabinet sensor is attached to a tie mount at the top of the inside of the cabinet.

The soft serve control board monitors the left sensor. When the resistance of the sensor equals the standby/serve potentiometer, the control board shuts off the compressor.

The IntelliTec control board monitors the right sensor. In "Serve Mode", when the temperature of the sensor equals the Cut In T value on the control, a freezing cycle will start.

When troubleshooting a sensor, refer to the wiring diagram and remove the wires from the control board (and serve/standby switch if on the soft serve side). Measure the resistance of the sensor and compare it with the table below. If the resistance is not within this range, replace it.

**SHAKE SENSOR RESISTANCE**

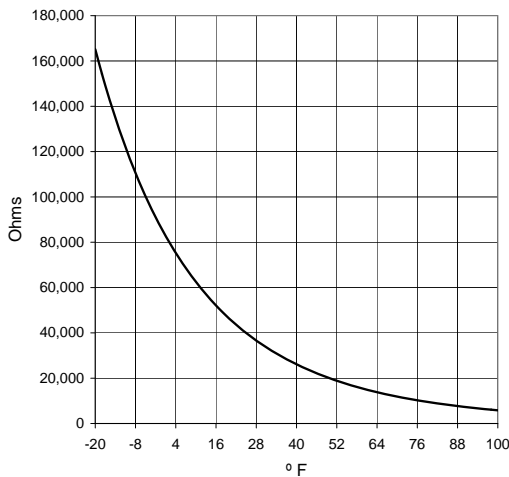

**Figure 6-9 Right Side & Cabinet Temperature Sensor**

**SOFT SERVE SENSOR RESISTANCE**

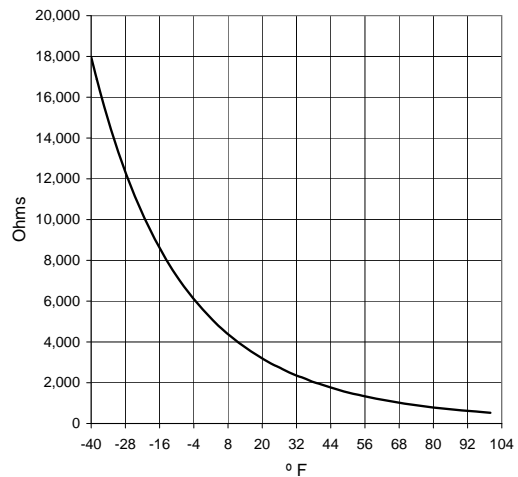

**Figure 6-10 Left Side Temperature Sensor**



# SECTION 7 TROUBLESHOOTING

## 7.1 ERROR CODES (RIGHT SIDE)

When the right side experiences a problem, one of the following error codes will be displayed on the IntelliTec control. Each error code directs you to the system location of the malfunction.

### ERROR CODE MALFUNCTION

1	Soft
2	High Torque
3	Extended Run Time
4	Clean
5	Barrel Sensor
6	Hopper Sensor
7	Drive Motor
8	Cab Sensor
9	High Pressure Cutout
10	Auxiliary Sensor
11	Low Temperature

To return the machine to normal operation, any error causing condition must be corrected and the Freezing Cylinder Off-On switch must be placed in the Off position and back in the On position before the affected side of the machine will return to normal operation.

## 7.2 TROUBLESHOOTING - ERROR CODES (RIGHT SIDE)

### Error Code 1 - Soft Error

The Soft Error (E1) is an internal control board error that is logged for future analysis. The refrigeration is never stopped and the machine will continue to operate normally.

### Error Code 2 - High Torque

If the control panel displays a High Torque Error (E2), the controller has sensed that the drive motor is running at 125% of the preset CutOut amp setting for 10 or more seconds. Very low and/or fluctuating supply voltages typically cause this error. The error can also be caused by faulty motor or starting components which could produce a high amp draw.

### Error Code 3 - Run Time

The Run Time Error (E3) occurs when the compressor runs continuously for 20 minutes without the product reaching consistency in "Serve Mode" or if the product does not reach proper temperature in "Sleep 2 Mode". This error is generally caused by very low mix levels in the machine's mix container or from product breakdown. Another common cause results from a restriction preventing mix from entering the

freezing cylinder. Check the mix in the cabinet. If the level mix is low, add mix. If there is a possibility that the mix is broken down, clean and sanitize the machine, and replace the mix with fresh product.

Ice crystals in the liquid mix container can clog the mix inlet system and prevent mix from entering the freezing cylinder. Thoroughly thaw mix per manufacturer's recommendations. To check for ice crystals, pour a small amount of product in the mix container through a clean and sanitized sieve or strainer. If ice crystals are in the mix, check the temperature of the machine's cabinet.

Check the condition of the neoprene hose running through the mix pump head. If it shows signs of wear, rotate or replace it as outlined in Section 3.

In air cooled machines, the Run Time Error may indicate that airflow within the machine has reduced or stopped. Check the sides and top of the machine for anything that would restrict airflow.

The Run Time Error may also occur if airflow within the machine has reduced or stopped. Check the sides and top of the machine for anything that would restrict airflow. Check the condenser filter and clean if necessary. Check the evaporator for frost that could restrict airflow.

The compressor will run continuously if a solenoid valve fails to open. This could be due to loose wiring, magnetic coil failure, a stuck valve or a faulty control board.

After the cause of the problem is found and remedied turn the Main Freezer Power switch Off and back On.

### Error Code 4 - Clean

If the machine is left in the Clean Mode for more than 20 minutes, the control panel will display a Clean Error (Error 04). This condition does not reflect a problem with the machine itself. The Clean Error has been programmed into the controller as a safeguard to protect the machine from potential damage caused by the machine being accidentally left in "Clean Mode". The control will attempt to restart itself after 5 minutes. The display will then flash and read Restart. To immediately clear the Clean Error, turn the Main Freezer Power switch Off and back On. After restarting the machine, a refrigeration cycle will begin. This protects the product in case the clean button was pressed by mistake.

### Error Code 5 - Freezing Cylinder Sensor

The Freezing Cylinder Sensor Error (E5) indicates a failure of the barrel sensor or an extreme out of

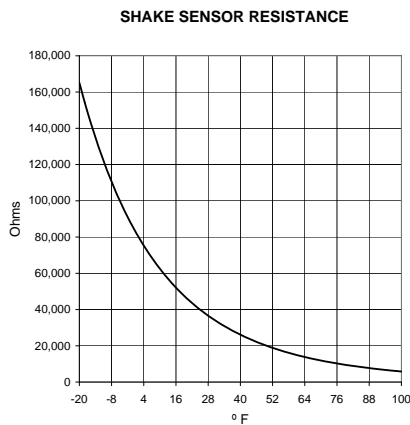

**Figure 7-1 Temperature Sensor Resistance**

range condition (< -34°F or > 99°F). If the control panel displays an E5, turn the Freezing Cylinder Off-On switch Off and back On. If the control panel still displays the error code, refer to the machine's wiring diagram and the Temperature Sensor Chart (Figure 7-1). Check each lead of the sensor to ground for continuity. If continuity is found, replace the sensor. To check the resistance of the sensor, place a thermocouple on the suction line at the exit of the freezing cylinder. Compare temperature and sensor resistance with the table as reference. If measured value does not coincide with a value on the table ( $\pm 400$  ohms), replace the sensor.

**NOTE**

*When the machine encounters a Freezing Cylinder Sensor Error, the machine will continue to run using preset timers. This mode will allow the operator to continue serving product until the machine can be serviced.*

**Error Code 6 - Hopper Sensor (single hopper machines)**

The Hopper Sensor Error (E6) will not occur on the machine.

**Error Code 7 - Drive Motor**

If the control panel displays a Drive Motor Error (E7), the control does not sense current coming from the drive motor. Turn the Freezing Cylinder Off-On switch Off and back On. If the error returns, use the machine's wiring diagram and check connections at the IntelliTec control and at the motor. An E7 may also be the result of a faulty drive motor contactor.

**Error Code 8 - Cab Sensor**

A Cab Sensor Error (E8) indicates a cabinet temperature sensor failure or. This error will also appear in an extreme out of range condition (< -34°F or > 99°F). If the control panel displays an E8, turn the Freezing Cylinder Off-On switch Off and back On. If the control panel still displays the error condition code, refer to the wiring diagram and the temperature sensor value table. Check each lead of the sensor to ground for continuity.52

If continuity is found, replace the sensor. Place a thermocouple in the cabinet evaporator discharge airstream (outlet air flow). Compare temperature to sensor resistance using the table as reference. If CutIn/CutOut values do not coincide with the values on the table, replace the sensor.

**Error Code 9 - High Pressure Cutout**

High Pressure Cutout Errors (E9) are usually caused by a dirty or inefficient condenser.

In air cooled condenser models, check the air filter to make sure it is clean. Replace or clean the filter as required. Check for proper air clearance around the machine. Refer to the machine's Owner's Manual for clearances. Check the condenser for blockage, and be sure condenser fan is functioning.

In water cooled condenser models check for proper water flow.

After the cause of the error is determined and corrected, turn the Freezing Cylinder Off-On switch Off and back On.

**Error Code 10 - Auxiliary Sensor**

An Auxiliary Temperature Sensor Error (R10) occurs if the temperature sensor on the control board fails. Turn the Freezing Cylinder Off-On switch Off and back On.

**Error Code 11 - Low Temperature**

The Low Temperature Error (E11) occurs when the temperature of the gas refrigerant at the freezing cylinder sensor falls below -20°F. Although the machine will not shut down, the active freezing cycle will immediately end. This error usually occurs when the machine continues to run in a low mix condition or if the machine runs out of mix. The product towards the front of the freezing cylinder tends to freeze solid. When the temperature on the freezing cylinder lowers to the preset value, the IntelliTec control will display an E11.

**COMMO TIMEOUT Error**

A COMMO TIMEOUT Error indicates a communication interruption between the display and the control board. This error can be caused by a poor connection or a faulty phone cable. Disconnect and reconnect the telephone cable at the control board. If the error does not clear, disconnect and reconnect the telephone cable at the display panel module. If the error still appears, the cable may be faulty or the display panel module may be faulty.

**ALTERNATING FLASHING CONTROL PANEL LIGHTS**

The display panel lights will flash in an alternating sequence under any error codes. Clear the error and turn the Freezing Cylinder Off-On switch Off and back On. The alternating lights will also illuminate if the Main Freezer Power switch is On and the Freezing Cylinder switch is Off.

## 7.3 TROUBLESHOOTING - FREEZER

PROBLEM	POSSIBLE CAUSE	REMEDY
<b>Drive motor (auger) “kicks-out”, or does not run.</b>	<ol style="list-style-type: none"> <li>1 Power to machine is off.</li> <li>2 Low line voltage.</li> <li>3 Product too hard.</li> <li>4 Front door not installed securely.</li> </ol>	<ol style="list-style-type: none"> <li>1 Check power to machine.</li> <li>2 Check, must be <math>\pm 10\%</math> of nameplate voltage.</li> <li>3 Increase overrun. (See Section 4.9)</li> <li>4 Install front door securely.</li> </ol>
<b>Compressor does not operate.</b>	<ol style="list-style-type: none"> <li>1 Power to machine is off.</li> <li>2 Drive motor overloaded or no current detected.</li> <li>3 Low line voltage.</li> <li>4 Compressor internal overload is cut-out.</li> <li>5 Front door not installed securely.</li> </ol>	<ol style="list-style-type: none"> <li>1 Check power to machine.</li> <li>2 Wait for 15-20 minutes for the thermal overload to reset.</li> <li>3 Check, must be <math>\pm 10\%</math> of nameplate voltage.</li> <li>4 Check condenser (air cooled) (See Sect. 4.14), or water supply (water cooled).</li> <li>5 Install front door securely.</li> </ol>
<b>Product too soft.</b>	<ol style="list-style-type: none"> <li>1 Right side CutOut setting is too low</li> <li>2 Left side temperature setting is too high.</li> <li>3 Product breakdown.</li> <li>4 Left side Standby/Serve switch in the Standby position</li> </ol>	<ol style="list-style-type: none"> <li>1 Adjust CutOut setting to match product requirements. (See Section 3.12)</li> <li>2 Adjust the temperature. (See Section 4.2)</li> <li>3 Fill with fresh product.</li> <li>4 Place the Standby/Serve switch in the Serve position.</li> </ol>
<b>Freeze-up. (Product will not dispense easily.)</b>	<ol style="list-style-type: none"> <li>1 Right side CutOut setting is too high.</li> <li>2 Left side temperature setting is too low.</li> <li>3 Low overrun setting.</li> <li>4 Low pump pressure.</li> <li>5 Large air pocket in barrel.</li> <li>6 Auger turning counter-clockwise.</li> <li>7 Pump hoses kinked.</li> </ol>	<ol style="list-style-type: none"> <li>1 Adjust CutOut setting to match product requirements. (See Section 3.12)</li> <li>2 Adjust the temperature. (See Section 4.2)</li> <li>3 Increase overrun. (See Section 4.9)</li> <li>4 Check pump pressure.</li> <li>5 Purge air from barrel.</li> <li>6 Change rotation to clockwise.</li> <li>7 Check pump hoses for bending or kinking.</li> </ol>
<b>Rear auger seal leaks.</b>	<ol style="list-style-type: none"> <li>1 Seal missing or installed wrong.</li> <li>2 Rear seal o-ring missing, broken or not lubricated.</li> <li>3 Worn or scratched shaft.</li> </ol>	<ol style="list-style-type: none"> <li>1 Install correctly. (See Section 3.9 and 3.10)</li> <li>2 Inspect for breakage and lubricate properly. (See Section 3.9 and 3.10)</li> <li>3 Replace shaft.</li> </ol>
<b>Spigot leaks.</b>	<ol style="list-style-type: none"> <li>1 Spigot parts are not lubricated.</li> <li>2 Chipped or worn o-rings.</li> <li>3 O-rings on spigot installed wrong.</li> <li>4 Nicks or scratched on front door where spigot is located.</li> </ol>	<ol style="list-style-type: none"> <li>1 Lubricate. (See Section 3.9 and 3.10)</li> <li>2 Replace o-rings.</li> <li>3 Remove spigot and check o-rings.</li> <li>4 Replace front door.</li> </ol>

<b>PROBLEM</b>	<b>POSSIBLE CAUSE</b>	<b>REMEDY</b>
<b>Drive belts slipping or squealing.</b>	1 Drive belt tension not correct. 2 Worn belt(s). 3 Low overrun.	1 Adjust belt tension. (See Section 4.13) 2 Replace belts. 3 Check for air leak.
<b>Mix temperature too warm in cab.</b>	1 Temperature control set too warm. 2 Cab door is open.	1 Decrease CabCtOut and CabCutIn (See Section 4.12) 2 Close the cab door.
<b>Mix temperature too cold in cab.</b>	1 Temperature control set too cold.	1 Increase CabCtOut and CabCutIn (See Section 4.12)
<b>Compressor makes loud noise</b>	1 Reversed scroll rotation	1 Change wiring.
<b>Fan motor doesn't operate or high head pressure</b>	1 Left side not connected to power supply. 2 Low line voltage.	1 Make sure the left side is connected to a power supply. 2 If line voltage is less than 215V, then the fan motor needs to be rewired (See Section 2.4)
<b>Not cooling at startup</b>	1 Reversed scroll rotation	1 Check compressor for proper power and reverse wiring if necessary (3 phase only). (See Section 2.5)
<b>IntelliTec displays CLEAN message (Right Side)</b>	1 The cabinet temperature has been above 50°F for 2 hours or more.	1 Check the cabinet temperature. Disassemble and clean the machine. (See Sections 3.4 to 3.11)

## 7.4 TROUBLESHOOTING - MIX PUMP

PROBLEM	POSSIBLE CAUSE	REMEDY
<b>Pump motor does not run.</b>	<ol style="list-style-type: none"> <li>1 Power to pump is off.</li> <li>2 Low voltage.</li> <li>3 Mix pump hose jammed inside black cover/clamp.</li> <li>4 Pump motor overloaded.</li> <li>5 Pressure switch on pump is defective.</li> <li>6 Defective motor/capacitor.</li> <li>7 Defective toggle switch.</li> </ol>	<ol style="list-style-type: none"> <li>1 Supply power to pump.</li> <li>2 Check for low voltage.</li> <li>3 Disconnect pump from power source. Remove four cover/clamp thumb screws. Separate cover/clamp halves and remove outer half. Remove jammed hose. Clean and re-install cover/clamp and tighten four thumb screws securely. Allow motor thermal overload to reset.</li> <li>4 Allow internal thermal overload to reset; determine overload cause and repair.</li> <li>5 Check mechanical operation and continuity of pressure switch.</li> <li>6 Check motor amperage draw and/or capacitor. Replace motor or capacitor.</li> <li>7 Check continuity; repair or replace.</li> </ol>
<b>Pump operates but cylinder will not fill.</b>	<p>Note 1: A properly working pump will fill an 8 oz. cup with mix in about 9 seconds.</p> <p>Note 2: Immediately after a bag change the pump may be unable to reestablish it's prime with the system at operating pressure. In this case, turn the pump off. Draw 2-3 pints to reduce system pressure to zero. Turn pump on. Purge remaining air in mix bag and pick-up hose.</p> <p><b>Important: before connecting the pick-up hose to the mix bag, remove as much air from the mix bag as possible.</b></p>	
	<ol style="list-style-type: none"> <li>1 Out of Mix.</li> <li>2 Mix pump hose kinked inside black cover/clamp.</li> <li>3 Hoses assembled incorrectly.</li> <li>4 Mix pump hose service life is exceeded.</li> <li>5 Mix pump hose not connected to machine.</li> <li>6 Ice crystals in mix.</li> <li>7 Mix bag drawn against adapter.</li> <li>8 Foreign objects in mix.</li> <li>9 Check valve is backwards.</li> </ol>	<ol style="list-style-type: none"> <li>1 Replenish mix supply.</li> <li>2 Disconnect pump from power source. Remove four cover/clamp thumb screws. Separate cover/clamp halves and remove outer half. Remove jammed hose. Clean and re-install cover/clamp and tighten four thumb screws securely. Allow motor thermal overload to reset.</li> <li>3 Refer to diagram for correct hose connections.</li> <li>4 Reposition/replace mix pump hose. See Section 4.9</li> <li>5 Connect mix pump hose to machine.</li> <li>6 Completely thaw mix prior to use.</li> <li>7 Ensure bag is clear of pick-up tube.</li> <li>8 Clear blockage. Use fresh mix.</li> <li>9 Observe flow arrow for proper orientation.</li> </ol>
<b>Overrun too low or no overrun.</b>	<ol style="list-style-type: none"> <li>1 Overrun setting too low.</li> <li>2 Air leak.</li> <li>3 Air compressor not pumping air.</li> <li>4 Air check valve in backwards.</li> </ol>	<ol style="list-style-type: none"> <li>1 Increase overrun setting.</li> <li>2 Tighten all hose clamps.</li> <li>3 Contact local Stoelting Distributor.</li> <li>4 Check arrow for direction of flow.</li> </ol>

PROBLEM	POSSIBLE CAUSE	REMEDY
<b>Overrun too high.</b>	<ol style="list-style-type: none"> <li>Mix pump hose service life is exceeded.</li> <li>Out of mix.</li> <li>Overrun setting too high.</li> <li>Pick-up leg of mix pump hose is collapsing.</li> </ol>	<ol style="list-style-type: none"> <li>Reposition/replace mix pump hose.</li> <li>Replenish mix supply.</li> <li>Decrease overrun setting.</li> <li>Reposition hose.</li> </ol>
<b>Replacement mix pump hose won't feed through pump.</b>	<ol style="list-style-type: none"> <li>Feeding hose into discharge hole of mix pump cover.</li> <li>Hose ends not cut squarely.</li> <li>Force feeding too quickly.</li> <li>Pump motor not running.</li> </ol>	<ol style="list-style-type: none"> <li>Feed hose into suction side of cover.</li> <li>Carefully cut hose end off squarely (no tails).</li> <li>Gently and slowly assist feeding of hose up into pick-up hose side of cover.</li> <li>Turn on motor switch.</li> </ol>
<b>Air exiting mix pick-up hose.</b>	<ol style="list-style-type: none"> <li>Pickup tube check valve missing.</li> </ol>	<ol style="list-style-type: none"> <li>Contact local Stoelting Distributor.</li> </ol>
<b>Dispensed product air "pops"</b>	<ol style="list-style-type: none"> <li>Overrun setting too high.</li> <li>Mix pump hose service life is exceeded.</li> <li>Overdrawing the machine's capacity.</li> <li>Recent low mix condition.</li> </ol>	<ol style="list-style-type: none"> <li>Decrease overrun setting.</li> <li>Reposition/replace mix pump hose.</li> <li>Reduce dispense rate.</li> <li>Open spigot fully and allow excess air to escape.</li> </ol>
<b>Mix leakage from pump.</b>	<b>CAUTION: To prevent mix pump damage from dried mix deposits, immediately disassemble and clean pump.</b>	
	<ol style="list-style-type: none"> <li>Mix pump hose service life is exceeded.</li> </ol>	<ol style="list-style-type: none"> <li>Remove mix pump hose. Disconnect pump from power source. Remove mix pump cover/clamp. Clean the rollers a small amount of soapy water. Clean mix from pump. See Section 4.2 for hose replacement.</li> </ol>
<b>Pump is noisy/ squeaking.</b>	<p>Note: The action of the air compressor rocking arm creates a repetitive clicking sound during operation. This is normal.</p> <p>Note: The peristaltic mix pump has three squeeze rollers that use self lubricating bearings. If squeaking exists with the mix pump hose in place and stops with the hose removed, the squeeze roller bearings can be lubricated using a silicone based spray. Remove the mix pump hose. Disconnect pump from electrical power. Remove four cover/clamp thumbscrews. Remove entire cover/clamp as one unit. Spray silicone based lubricant on each end of each squeeze roller. Spin rollers to work lubricant into bearings. Repeat as needed.</p> <p><b>Caution: Do not use cleaning/dissolving type lubricants like wd-40. These lubricants are not bearing friendly and will accelerate bearing wear.</b></p>	
<b>Mix in air hoses.</b>	<ol style="list-style-type: none"> <li>Air/mix tee above black cover/clamp.</li> <li>Air leak.</li> <li>Mix hose on wrong air/mix tee fitting.</li> </ol>	<ol style="list-style-type: none"> <li>Air/mix tee must be below black cover/clamp.</li> <li>Check stainless steel tube connection. Tighten all hose clamps.</li> <li>Refer to diagram for correct hose connections.</li> </ol>

## SECTION 8 REPLACEMENT PARTS

### 8.1 BRUSHES, DECALS AND LUBRICATION

Part Number	Description	Quantity
208135	Brush - 4" X 8" X 16" (Barrel)	1
208380	Brush - 1/4" X 3" X 14"	1
208387	Brush - 1/2" X 5" X 24"	1
208465	Brush - 1" X 3-1/2" X 18"	1
208467	Brush - 3/8" X 1" X 5"	1
324103	Decal - Caution Rotating Shaft	1
324105	Decal - Caution Electrical Shock	1
324106	Decal - Caution Electrical Wiring Materials	1
324107	Decal - Caution Hazardous Moving Parts	1
324125	Decal - Danger Electric Shock Hazard	1
324141	Decal - Caution Rotating Blades	1
324208	Decal - Attention Refrigerant Leak Check	1
324346	Decal - Caution Hazardous Moving Parts	1
324509	Decal - Cleaning Instructions	1
324548	Decal - Adequate Ventilation 6"	1
324565	Decal - Temperature Adjustment	1
324566	Decal - Wired According To	1
324594	Decal - Attention Heat Sensitive	1
324686	Decal - Danger Automatic Start	2
324728	Decal - Contactor Identification	1
324796	Decal - Freezing	1
324797	Decal - Standby / Serve	1
324798	Decal - Clean/Off/Serve Switch	1
324799	Decal - Pump Off / On	2
324801	Decal - Mix Low	1
324803	Decal - Domed Stoelting Logo (Large) (Header Panel)	1
324804	Decal - Domed Stoelting Swirl (Header Panel)	1
324825	Decal - Main Freezer Power	1
324826	Decal - Cab Off	1
324827	Decal - Freezing Cylinder	1
324835	Decal - Blender Power On / Off	1
324837	Decal - Caution Blender	1
324887	Decal - Boost Transformer	1
324901	Decal - Transformer Switch	1
508048	Lubricant - Spline (2 oz Squeeze Tube)	1
508135	Petrol Gel - 4 oz Tube	1
513639	Manual - Owner's	1

## 8.2 ACCESSORIES

Part Number	Description	Quantity
<a href="#">232734</a>	Cap - Rosette (Soft Serve)	2
<a href="#">236055</a>	Card - Cleaning Instructions	1
<a href="#">244138</a>	Caster - Non-Locking (4") (Each)	2
<a href="#">244139</a>	Caster - Locking (4") (Each)	2
<a href="#">624677-5</a>	O-Ring - Spigot Extension - Black (Soft Serve) (5 Pack)	1
<a href="#">2177072</a>	Extension - Spigot - 1.5" (Soft Serve)	-
<a href="#">2177073</a>	Extension - Spigot - 2.5" (Soft Serve)	1
<a href="#">2177074</a>	Extension - Spigot - 3.2" (Soft Serve)	-

## 8.3 KITS

Part Number	Description	Quantity
<a href="#">1177436</a>	Air Compressor Kit (Reed Valve, Piston & Cylinder Sleeve) (Cab)	-
<a href="#">1183170</a>	Sensor Replacement Kit (Soft Serve)	-
<a href="#">2171962</a>	Sensor Probe Kit (Shake)	-
<b><a href="#">2177917</a></b>	<b>Brush Kit</b>	<b>-</b>
<a href="#">208135</a>	Brush - 4" x 8" x 16" (Barrel)	1
<a href="#">208380</a>	Brush - 1/4" x 3" x 14"	1
<a href="#">208387</a>	Brush - 1/2" x 5" x 24"	1
<a href="#">208401</a>	Brush - 1" X 3" X 10"	1
<a href="#">208465</a>	Brush - 1" x 3-1/2" x 18"	1
<a href="#">208467</a>	Brush - 3/8" x 1" x 5"	1
<b><a href="#">2187308</a></b>	<b>O-Ring Kit</b>	<b>-</b>
<a href="#">624520</a>	O-Ring - Air Bleed Valve - Black (Soft Serve & Shake)	2
<a href="#">624598</a>	O-Ring - Spigot - Black	2
<a href="#">624607</a>	O-Ring - Check Valve Body - Black (Cab)	4
<a href="#">624614</a>	O-Ring - Spigot Body - Black (Shake)	2
<a href="#">624677</a>	O-Ring - Spigot Extension - Black (Soft Serve)	1
<a href="#">624678</a>	O-Ring - Rear Seal - Black (Soft Serve & Shake)	2
<a href="#">625133</a>	O-Ring - Front Door - Red (Soft Serve)	1
<a href="#">625314</a>	O-Ring - Front Door - Black (Shake)	1

## 8.4 PANELS AND SCREWS

Part Number	Description	Quantity
<a href="#">647886</a>	Screw - Panel (All Upper)	-
<a href="#">647900</a>	Screw - Panel (All Lower)	-
<a href="#">649114</a>	Screw - Panel (Front Drip Tray) & Fan Guard (Cab)	-
<a href="#">2187125</a>	Panel - Front Drip Tray	1
<a href="#">2187133</a>	Panel - Upper Back	1
<a href="#">2187134</a>	Panel - L.H. Side (Upper)	1
<a href="#">2187143</a>	Panel - Header	1
<a href="#">2187144</a>	Panel - Top (Air-Cooled)	1
<a href="#">2187849</a>	Panel - R.H. Side & L.H. Side (Lower)	2
<a href="#">2187851</a>	Panel - Lower Back	1
<a href="#">2187963</a>	Panel - R.H. Side (Upper)	1
<a href="#">2202010</a>	Panel - Upper Front	1

## 8.5 LEFT SIDE AUGER SHAFT AND FRONT DOOR PARTS

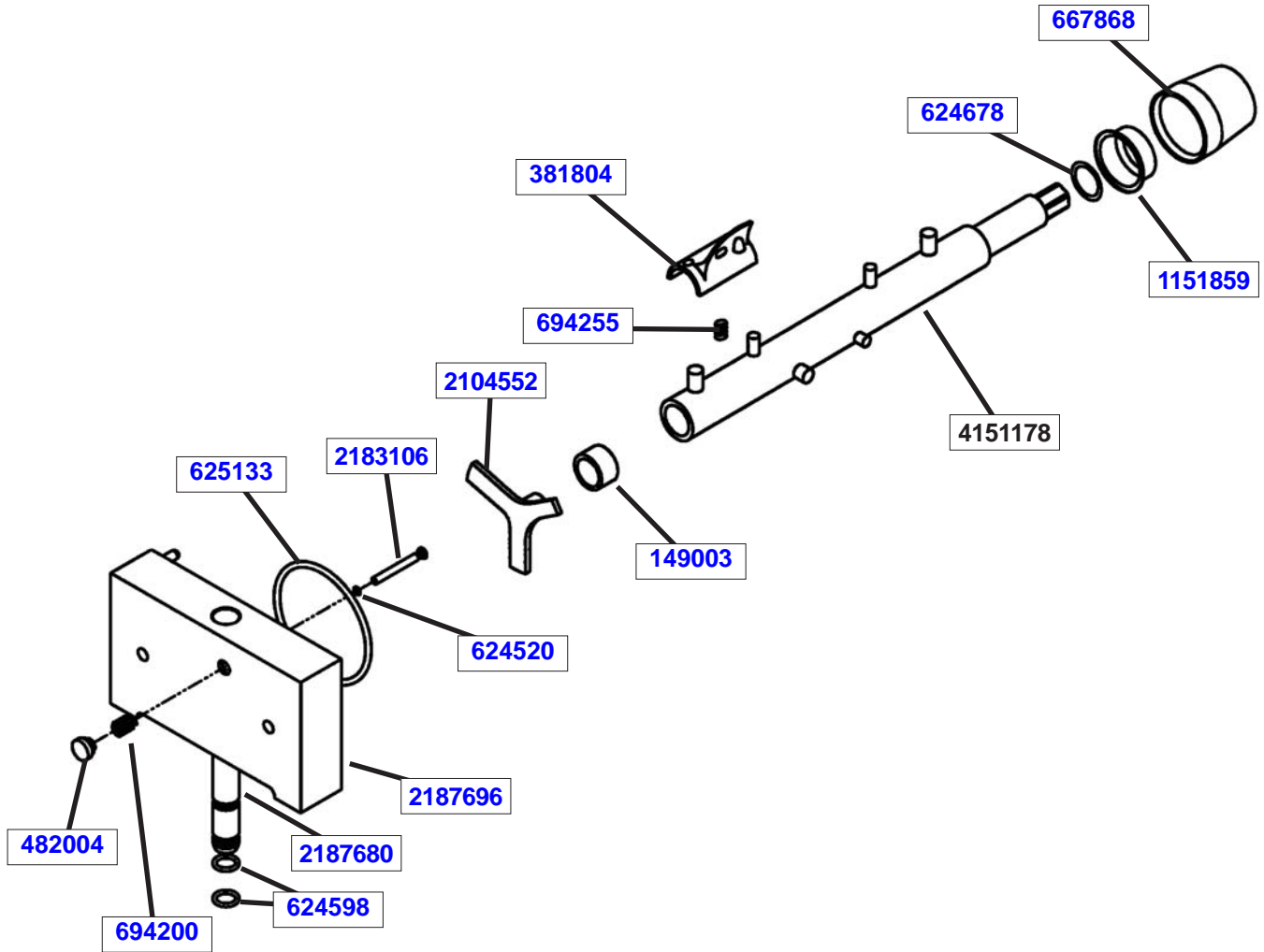

Part Number	Description	Quantity
149003	Bushing - Front Auger Support	1
381804	Auger Flight	6
482004	Knob (Air Bleed Valve & Blender Motor)	7
624520	O-Ring - Air Bleed Valve - Black	1
624598	O-Ring - Spigot - Black	2
624678	O-Ring - Rear Seal - Black	1
625133	O-Ring - Front Door - Black	1
667868	Seal - Rear Auger (Orange)	1
694200	Spring - Air Bleed Valve	1
694255	Spring - Auger Flight	6
1151859	Adapter - Rear Seal (Code 1)	1
2104552	Support - Front Auger	1
2183106	Valve - Air Bleed	1
2187680	Spigot Body	1
2187696	Front Door	1
4151178	Auger Shaft	1

## 8.6 RIGHT SIDE AUGER SHAFT AND FRONT DOOR PARTS

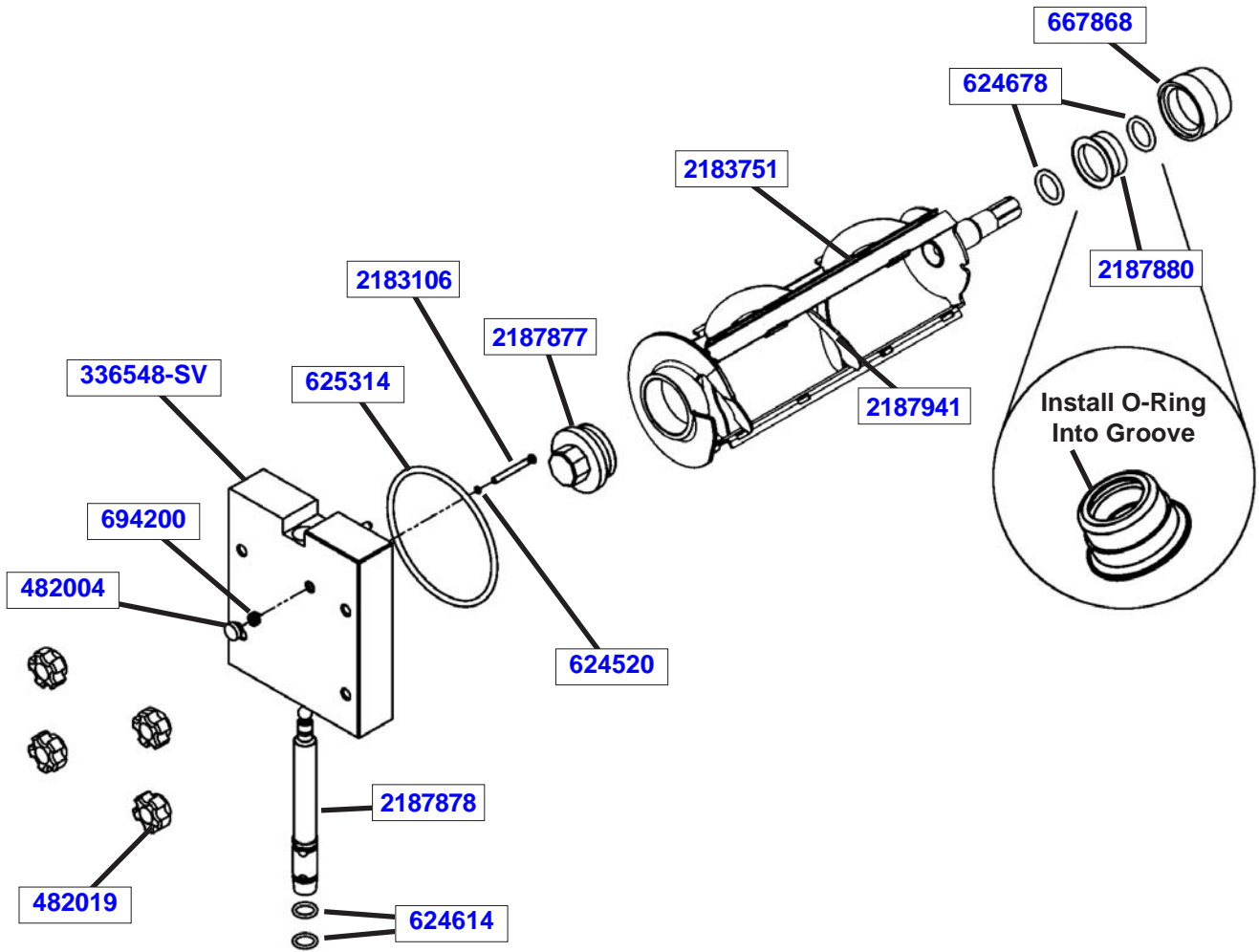

Part Number	Description	Quantity
336548-SV	Front Door	1
482004	Knob (Air Bleed Valve)	1
482019	Knob - Front Door (Black)	1
624520	O-Ring - Air Bleed Valve - Black	2
624614	O-Ring - Spigot - Black	2
624678	O-Ring - Rear Seal - Black	2
625314	O-Ring - Front Door - Black	1
667868	Seal - Rear Auger (Orange)	1
694200	Spring - Air Bleed Valve	1
2183106	Valve - Air Bleed	1
2183751	Scraper Blade	3
2187877	Bushing - Front Auger Support	1
2187878	Spigot Body	1
2187880	Adapter - Rear Seal	1
2187941	Auger Shaft	1

## 8.7 BLENDER PARTS AND DRIP TRAY

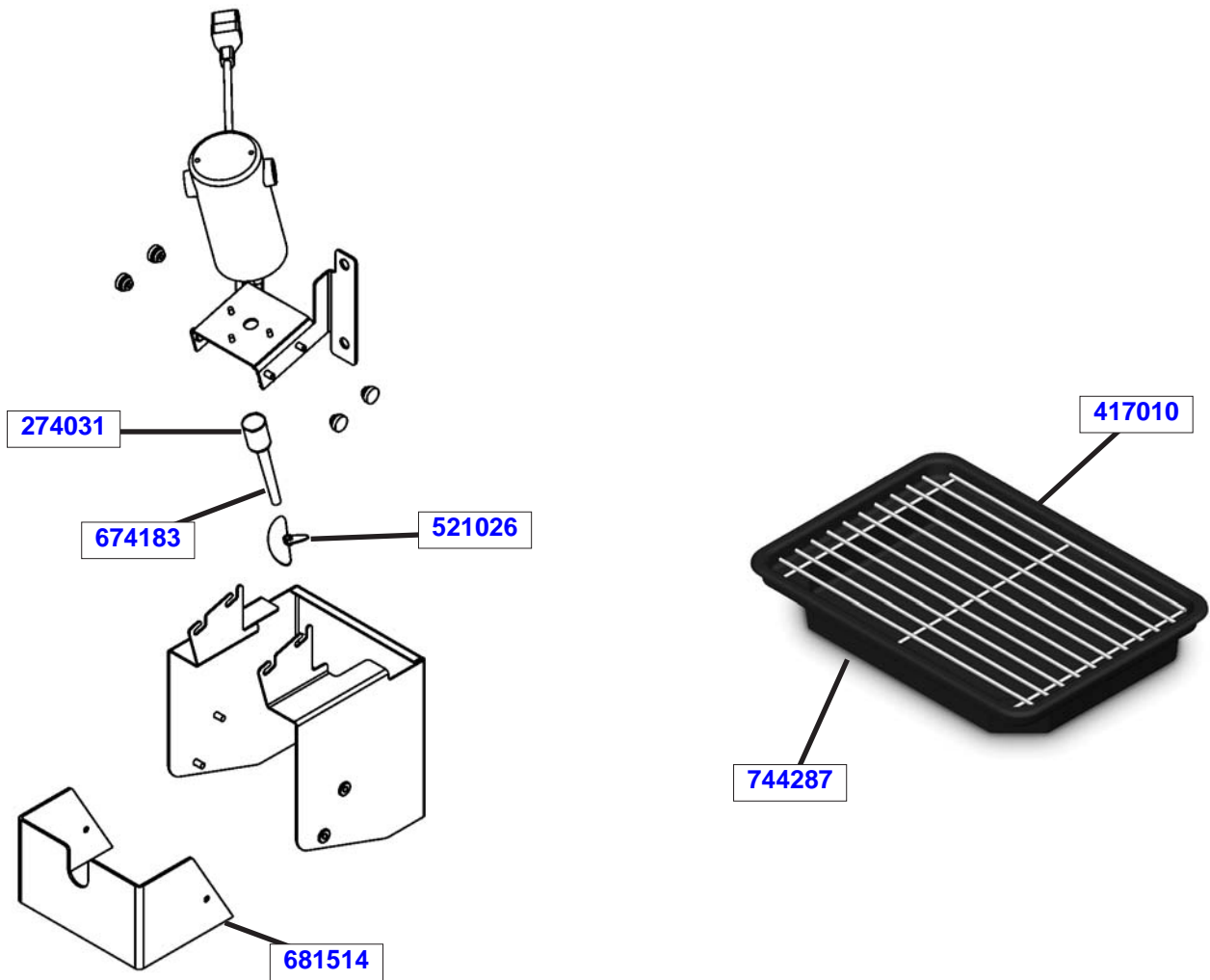

Part Number	Description	Quantity
274031	Blender Agitator Collar	1
417010	Grid - Drip Tray (Metal)	1
521026	Blender Agitator	1
674183	Blender Shaft	1
681518	Swing Shield (Plastic)	1
744262	Tray - Drain (Shake)	1
744276	Tray - Drain (Soft Serve)	1
744287	Tray - Drip	1

8.8 MACHINE FRONT

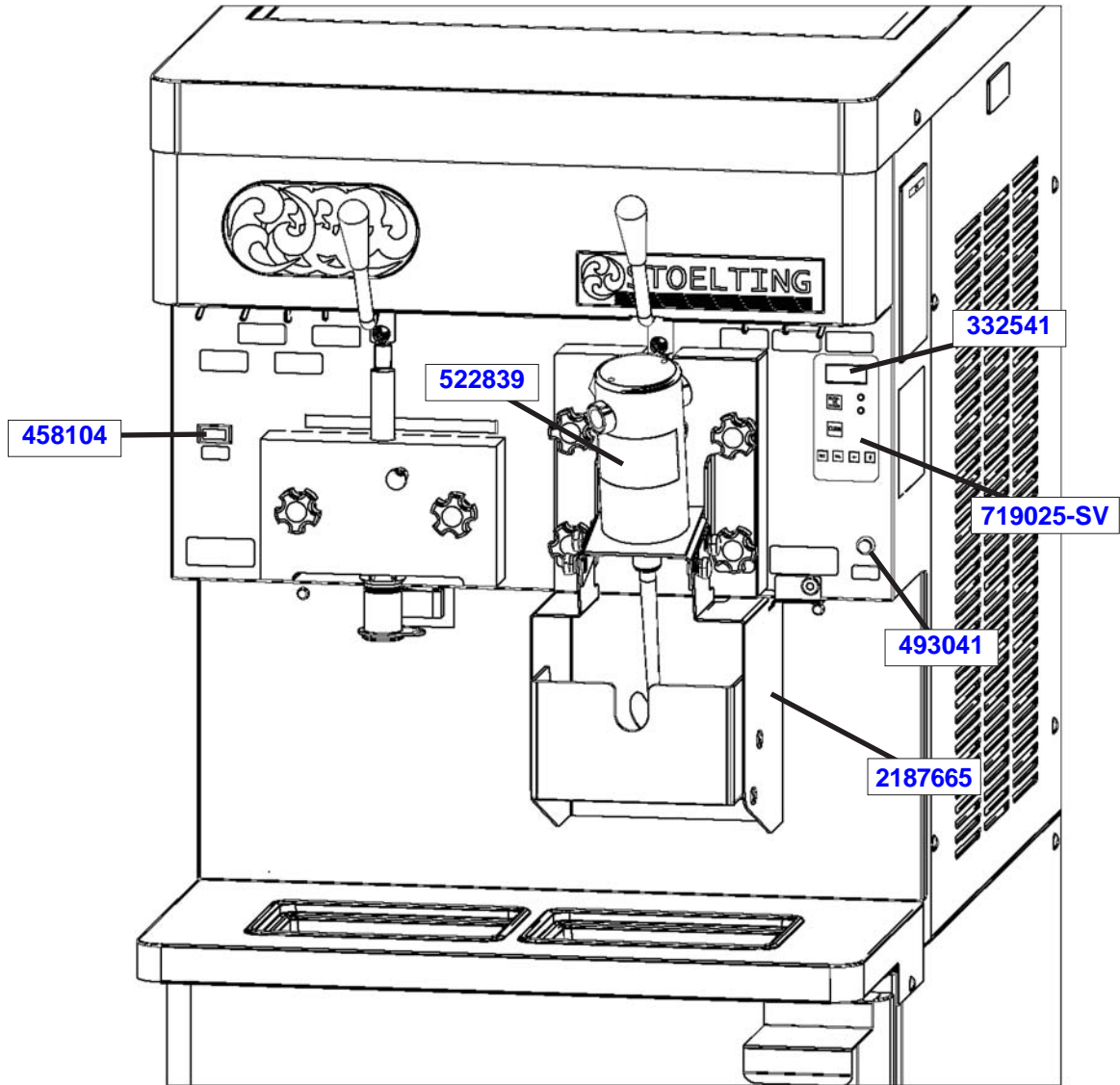

Part Number	Description	Quantity
332541	Board - Display Module (Display Only)	1
431041	Harness - Variable Speed Control (Shake)	1
458104	Indicator Light - Mix Low (Red)	1
493041	Indicator Light (Cab On - Off)	1
493042	Flasher - Indicator Light (Cab On - Off)	1
522839	Blender Motor	1
719025-SV	Switch - Membrane Strip	1
2187665	Bracket - Splash Shield	1

## 8.9 SPIGOT ASSEMBLIES

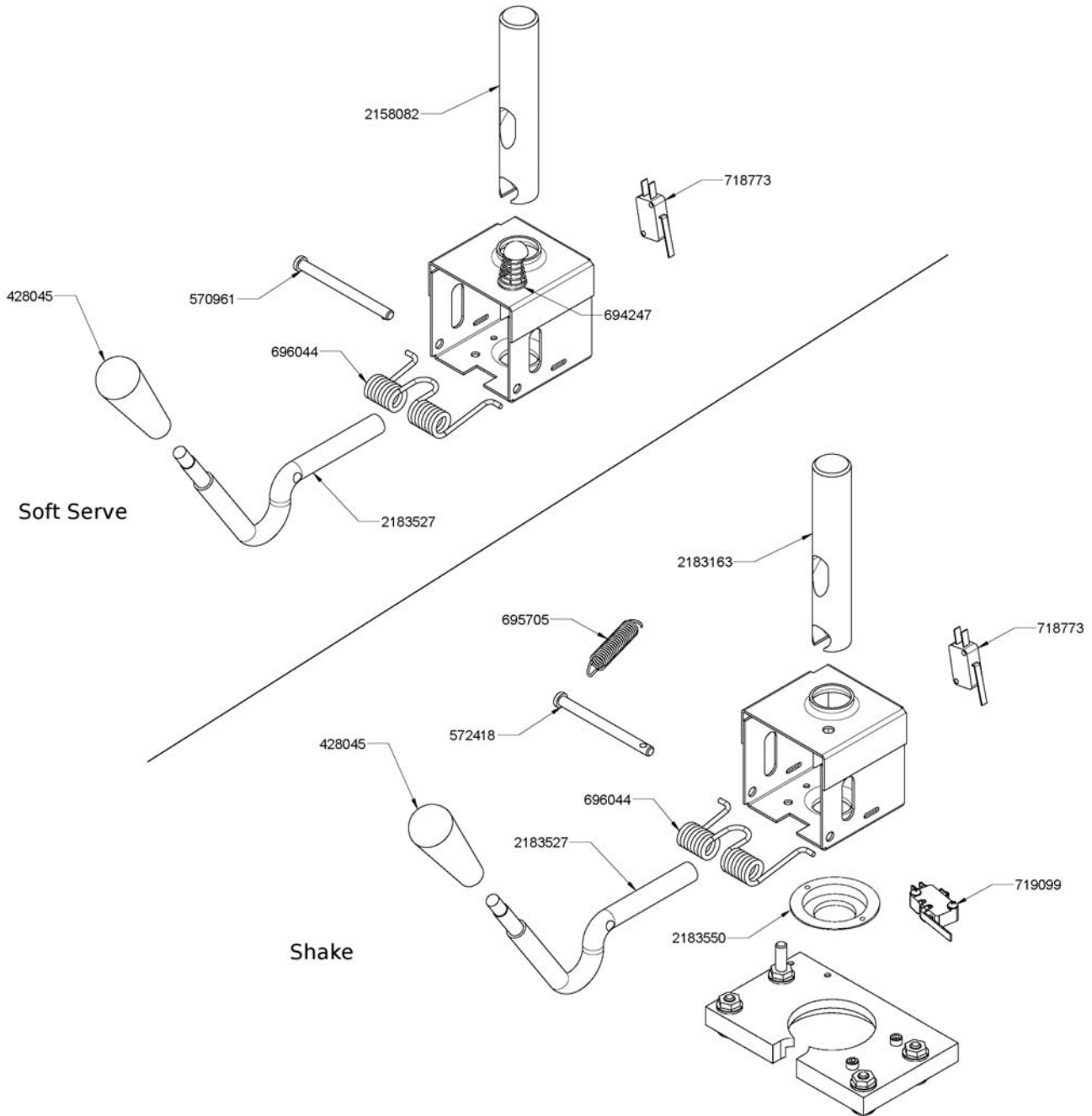

Part Number	Description	Quantity
428045	Knob - Spigot Handle (Black) (Soft Serve & Shake)	2
570961	Pin - Cotterless Clevis (Spigot Cam) (Soft Serve)	1
572418	Pin Cotterless Clevis (Spigot Cam) (Shake)	1
694247	Spring - Cone (Spigot Cam) (Soft Serve) & (Cab Check Valve)	1
695705	Spring - Blender Activation	1
696044	Spring - Torsion (Spigot Cam) (Soft Serve & Shake)	2
718773	Switch - Spigot (Soft Serve & Shake)	2
719099	Switch - Limit (Spinner Activation)	1
2158082	Glide - Spigot Socket (Soft Serve)	1
2183163	Glide - Spigot Socket (Shake)	1
2183527	Handle - Spigot (Soft Serve & Shake)	2
2183550	Collar - Spigot (Shake)	1

## 8.10 CAB INTERIOR

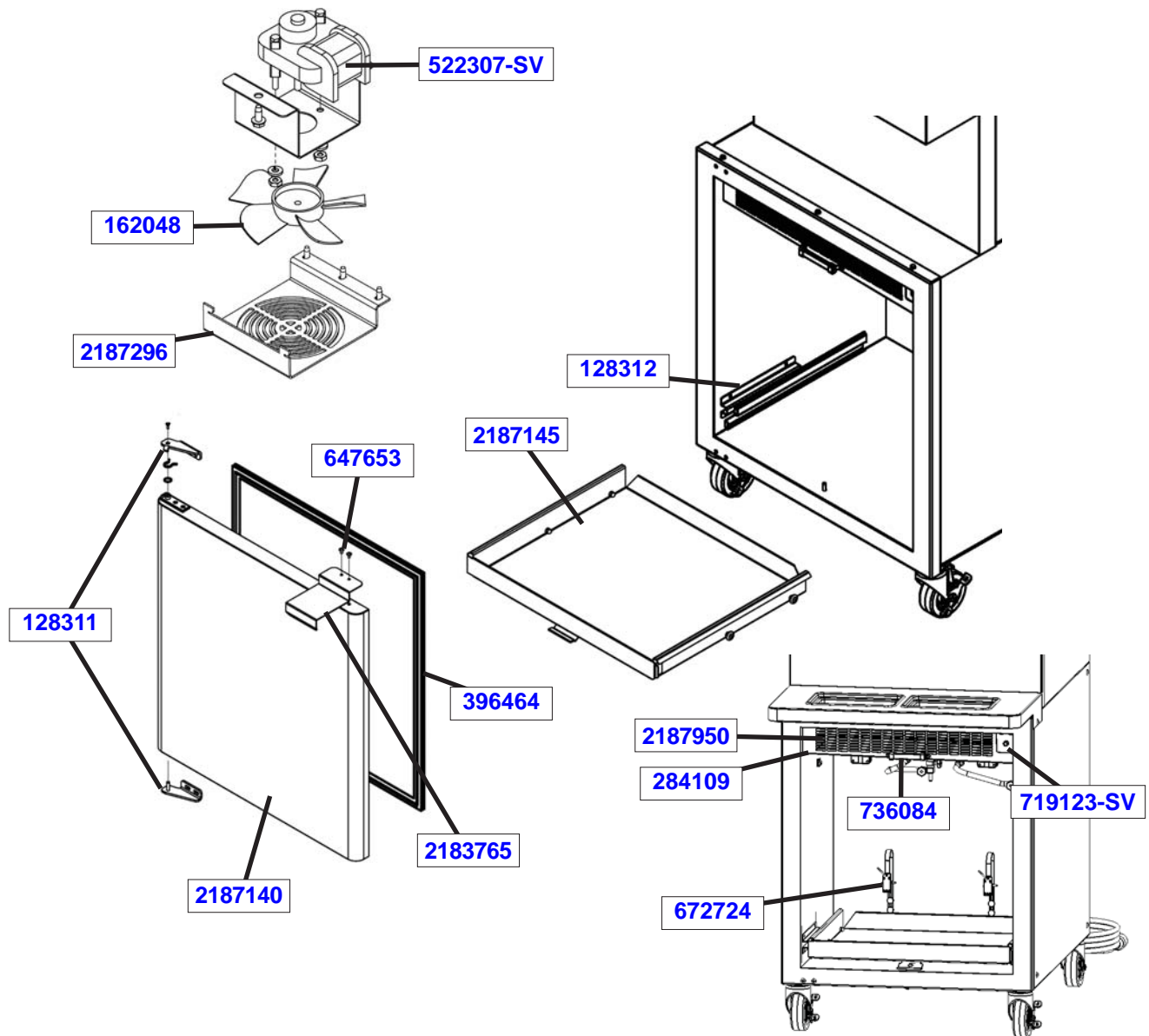

Part Number	Description	Quantity
128311	Hinge - Door (Top & Bottom) (Cab)	1
128312	Mix Container Holder Assembly w/Rollers (Cab)	1
162048	Blade - Fan (Evaporator) (Cab)	1
284109	Evaporator (Cab)	1
396464	Gasket - Door (Cab)	1
522307-SV	Motor - Fan (Evaporator Assembly) (Cab)	1
647653	Screw - Cab Door Handle (Cab)	-
653022	Screw - Thumb (Cab Shroud to Evaporator) (Cab)	4
672724	Sensor - Capacitive (Cab)	2
719123-SV	Switch Only - Cab Door (Cab)	1
736084	Thermometer (Cab)	1
1183096	Adaptor - Manifold (Cab)	1
2183765	Handle - Door (Cab) (Cab)	1
2187140	Door Assembly - Foamed (Cab)	1
2187145	Mix Container Holder (Cab)	1
2187296	Guard - Fan (Cab)	1
2187950	Shroud (Cab Evaporator)	1
2187926	Motor - Fan (Evaporator Assembly) (50 Hz) (Cab)	1

## 8.11 CAB TUBING

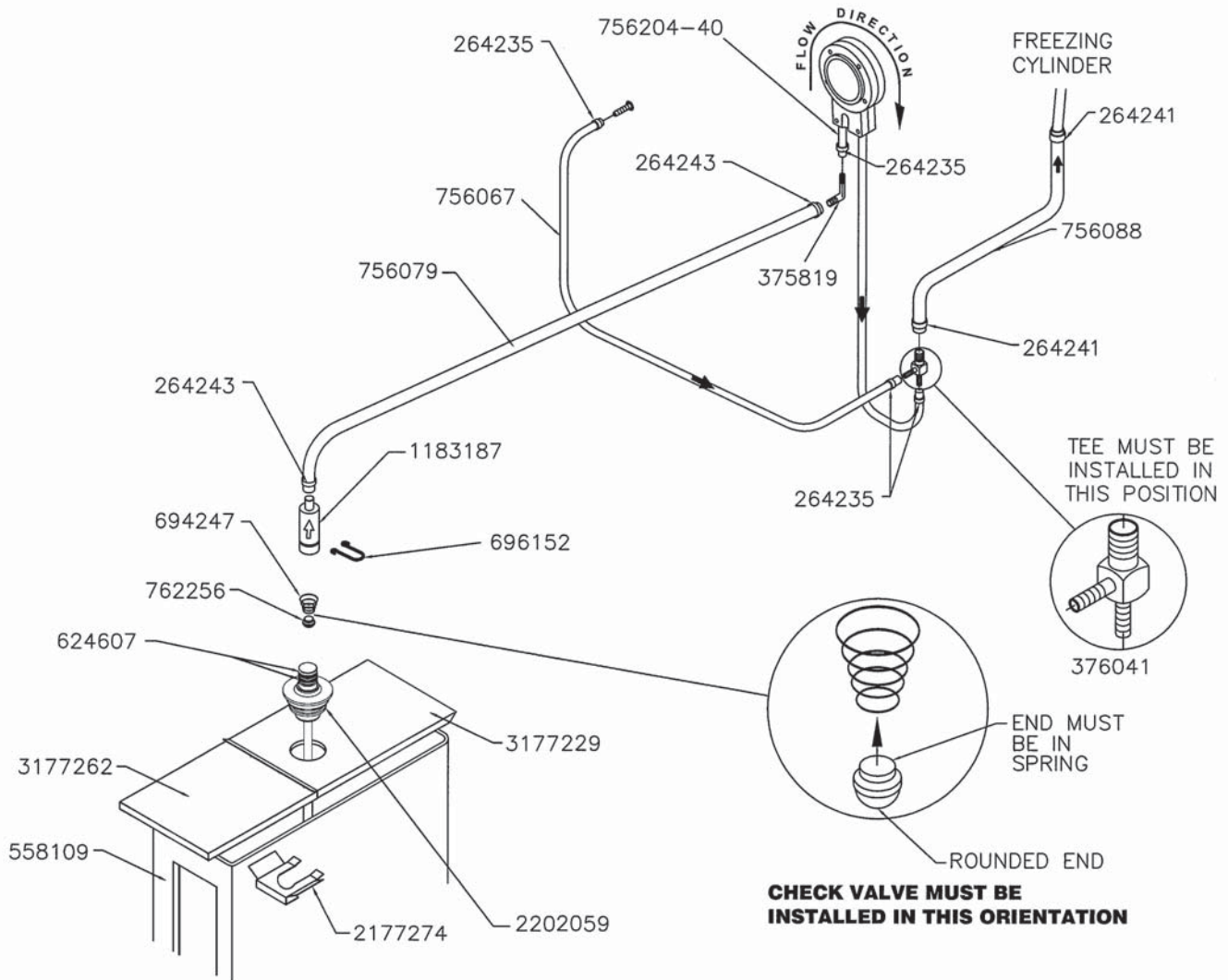

Part Number	Description	Quantity
264235	Clamp - Metal (1/4" ID Tubing) (Cab)	8
264241	Clamp - Metal (1/2" ID Tubing) (Cab)	4
264243	Clamp - Metal (3/8" ID Tubing) (Cab)	8
375819	Elbow - Barbed (3/8" - 1/4") (Cab)	2
376041	Tee Connector - 3-Way (Stainless) (Cab)	2
558109	Mix Container Only (Cab)	2
624607	O-Ring - Check Valve Body - Black (Cab)	4
694247	Spring - Cone (Spigot Cam) (Soft Serve) & (Cab Check Valve)	2
696152	Clip - Lock (Check Valve) (Cab)	6
756067	Tubing - 1/4" ID - Clear - Air Line (25' Increments) (Per Inch)	Two 13"
756079	Tubing - 3/8" ID - Clear - Mix Line (25' Increments) (Per Inch)	Two 24"
756088	Tubing - 1/2" ID - Clear - Mix Line (25' Increments) (Per Inch)	Two 6"
756204	Tubing - 1/4" ID - Pump (50' Box Only) (Per Inch) (Cab)	-
756204-40	Tubing - 1/4" ID - Pump (Pre-Cut 40" Piece) (Cab)	8
762256	Check Valve - Mix Outlet (Cab)	2
1183187	Check Valve - Mix In Line (Outer) (Cab)	2
2177274	Clip - Retaining (Mix Probe To Cover) (Cab)	2
2202059	Pick-Up Tube - Mix (Cab)	2
3177229	Cover - Rear (Mix Container) (Cab)	2
3177262	Cover - Front (Mix Container) (Cab)	2

## 8.12 PUMP PARTS

Part Number	Description	Quantity
150809	Belt (Shake) (Cab)	1
369037	Fitting - Flared - Air Inlet (Cab)	2
376035	Tee Connector - Air Pressure Switch (Cab)	2
432003-SV	Valve Head Only w/Tubes (Pump) (Cab)	2
522229	Motor - Pump (Cab)	2
598025	Pulley - Large (Shake) (Cab)	1
650146	Set Screw - Pulley (Cab)	2
652412	Screw - Shoulder (Crank Arm Roller Assembly) (Cab)	2
653042	Screw - Thumb (Cover Clamp) (Cab)	8
667896	Seal - Bumper (Piston) (Pump) (Cab)	2
717928	Switch - Pressure (Pump) (Soft Serve) (Cab)	1
717937	Switch - Pressure (Pump) (Shake) (Cab)	1
762246	Check Valve - Air Line (Stainless) (Cab)	2
766058	Washer - Lock - Motor Mounting (Cab)	8
1171860	Spring - Check Valve (Pump) (Cab)	2
1171861-SV	Needle Valve w/O-Ring (Pump) (Cab)	2
1171862	Screw - Air Filter Retainer (Cab)	2
1171863	Valve Guide (Pump) (Cab)	2
1171864	O-Ring - Needle Valve (Pump) (Cab)	2
1171866	Screw - Valve Head (Cab)	10
1171867	O-Ring (Pump Cylinder Sleeve) (Cab)	2
1171868	Reed Valve (Pump) (Cab)	2
1171870	Cylinder Sleeve (Pump) (Cab)	2
1171871	Spring - Piston (Cab)	2
1171872	Piston Spring Seat (Cab)	2
1171873	Piston (Pump) (Cab)	2
1171874	Ball Bearing - Single (Pump Rocker Arm) (Cab)	2
1171955	Set Screw - Eccentric (Cab)	2
1171956	Washer - Crank Arm - Nylon (Cab)	2
1171958	Filter - Air (Pump) (Cab)	2
1171959	O-Ring (Piston) (Pump) (Cab)	2
1171977	Roller (Crank Arm) (Cab)	2
1171978	Screw - Crank Arm (Cab)	2
1171979	Crank Arm (Cab)	2
1171980	Pulley - Large (Pump) (Soft Serve) (Cab)	1
1171981	Eccentric (Cab)	2
1171982	Knob - Crank Arm Overrun Setting (Cab)	2
1171983	Dial - Crank Arm Overrun Setting (Cab)	2
1171984	Pointer - Crank Arm Overrun Setting (Cab)	2
1171985	Dowel Pin - Rocker Arm (Cab)	2
1171986	Flange Bearing - Rocker Arm (Cab)	4
1171987	Wick - Rocker Arm (Cab)	2
1171988	Collar - Rocker Arm Dowel Pin (Cab)	2
1171989	Pulley - Small (Soft Serve & Shake) (Cab)	2
1171990	Belt (Soft Serve) (Pump) (Cab)	1
1171994	Sleeve Bearing - Crank Arm (Cab)	2
1177033	Bumper Ring (Piston) (Pump) (Cab)	2
1177034	Air Filter Retainer - Top (Cab)	2
1177035	Air Filter Retainer - Bottom (Cab)	2
1177036	Washer - Air Filter Retainer (Cab)	2
1177037	Screw - Air Filter (Cab)	2
1177681	Rocker Arm (Cab)	2
2177812	Roller Carrier Assembly Kit (Cab)	-
2183067	Pump Body Casting (Cab)	2
3171952	Cover - Clamp (Two Piece Black) (Cab)	2

## 8.12 PUMP PARTS (CONTINUED)

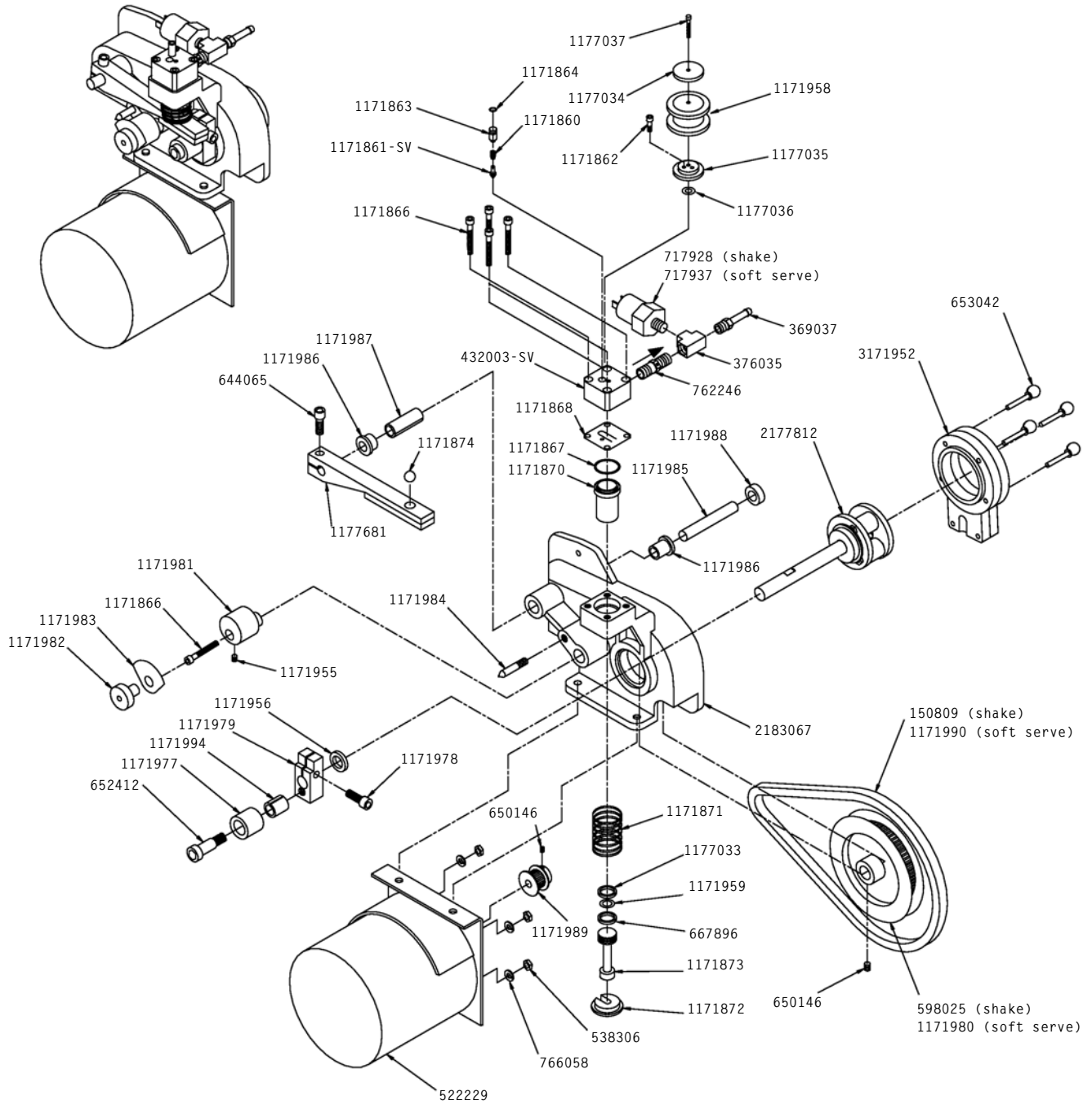

### 8.13 HEADER PANEL - ELECTRICAL

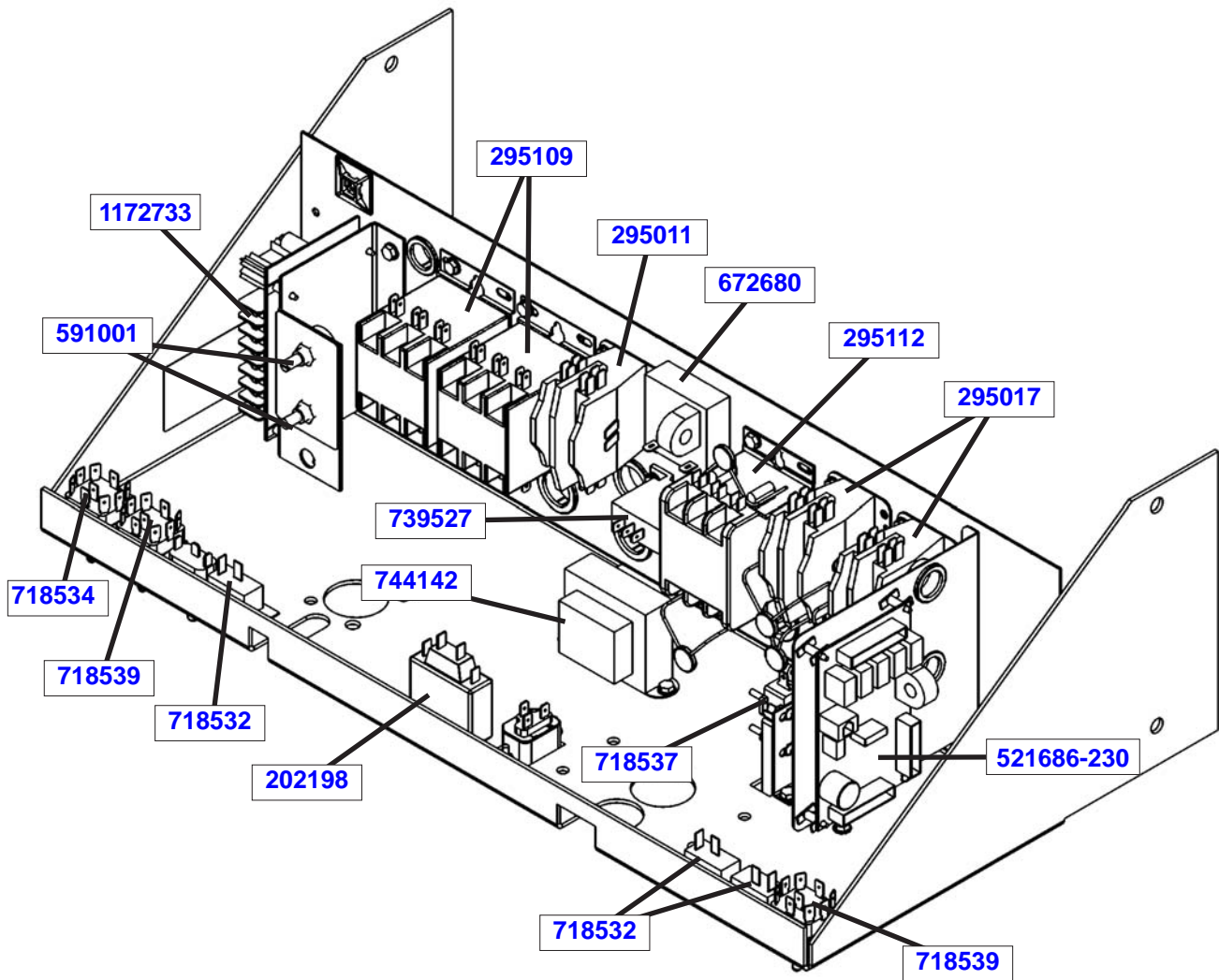

Part Number	Description	Quantity
202198	Switch - Blender Power & Reset	1
229115	Cable - Phone (Control Board To Display Board)	1
295011	Contactors (Air-Cooled Condenser Motor)	1
295017	Contactors (45CG20AG) (Drive Motor & Cab) (Shake)	2
295109	Contactors (42AF35AJ) (Drive Motor & Compressor) (Soft Serve)	2
295112	Contactors - Compressor (42BE35AG) (Shake)	1
521686-230	Program Board - IntelliTec (208V / 230V) (Shake)	1
591001	Potentiometer (Soft Serve)	2
672680	Sensor - Current - 24 VAC	1
718532	Switch - Toggle (Pump On/Off) (Freezing Cylinder On/Off)	3
718534	Switch - Toggle (Clean-Off-Serve)	1
718537	Switch - Limit (Spinner Safety) (Door Safety)	3
718539	Switch - Toggle (Standby-Serve) (Main Power)	1
739527	Timer - Clean	1
744142	Transformer (Shake)	1
1172733	Temperature Control Kit (Soft Serve)	1

8.14 RIGHT SIDE

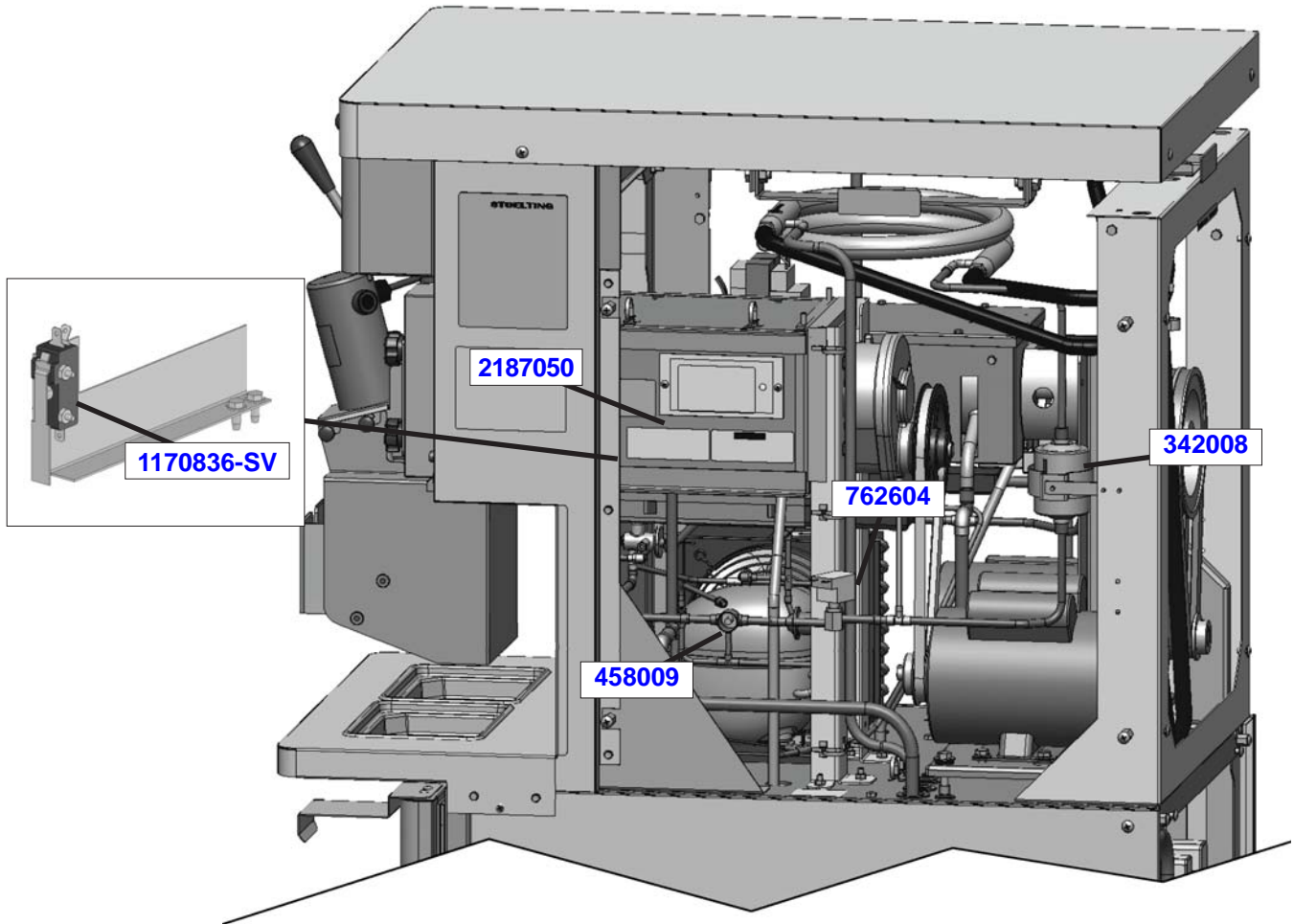

Part Number	Description	Quantity
284107	Condenser (Air-Cooled)	1
342008	Drier (Liquid Line)	2
357102	Motor - Fan (Air-Cooled Condenser) (Includes Blade & Guard)	1
368438	Filter - Air (Condenser)	1
458009	Indicator - Liquid Line (Sight Glass)	2
762604	Valve - Solenoid (Liquid Line)	2
1170836-SV	Switch Assembly - Limit (Spinner Safety)	1
2187050	Evaporator Assembly (Soft Serve)	1

## 8.15 REAR

Part Number	Description	Quantity
107315	Accumulator (Soft Serve)	1
152234	Belt - Gripnotch (AX33) (Soft Serve)	1
152237	Belt - Gripnotch (AX35) (Shake)	1
152238	Belt - Gripnotch (AX34) (Soft Serve 50 Hz)	1
230622	Capacitor - Start (#522856 Motor)	1
230638	Capacitor - Start (#282062 & #282082 Compressor)	2
230653	Capacitor - Run (#282062 Compressor)	1
230654	Capacitor (Fan Motor)	1
231047	Capacitor - Run (#282082 Compressor)	1
231075	Capacitor - Run (#522856 Motor)	1
231078	Capacitor - Run (#522858 Motor)	1
231095	Capacitor - Start (#522858 Motor)	1
266018	Clip - "J" (Hose Holder) (Cab)	1
282062	Compressor - 1 PH - 60 Hz (Scroll) (No Capacitors) (Shake)	1
282075	Compressor - 3 PH - 60 Hz (Scroll) (No Capacitors) (Shake)	1
282080	Compressor - 3 PH - 50 Hz (Scroll) (No Capacitors) (Shake)	1
282082	Compressor - 1 PH - 60 Hz (Scroll) (No Capacitors) (Soft Serve)	1
282083	Compressor - 3 PH - 60 Hz (Scroll) (No Capacitors) (Soft Serve)	1
282085	Compressor - 3 PH - 50 Hz (Scroll) (No Capacitors) (Soft Serve)	1
302042	Cord - Power (1 PH)	2
302043	Cord - Power (3 PH)	2
522853	Motor - Drive (3 PH, 380V-415V, 50 Hz)	1
522859	Motor - Drive (1 PH & 3 PH) (Soft Serve) (50 Hz)	1
522856-SV	Motor - Drive (1 PH) (Soft Serve)	1
522858-SV	Motor - Drive (1 PH & 3 PH) (Shake)	1
522869	Motor - Drive (2 HP, 3 PH, 208V / 230V, 60 Hz) (Soft Serve)	1
558005	Condensate Pan	1
598072	Pulley - Drive Motor (Shake)	1
598245	Pulley - Speed Reducer (Shake)	1
599194	Pulley - Speed Reducer (Shake) (50 Hz)	1
614220	Speed Reducer (Soft Serve)	1
614232	Speed Reducer (Shake)	1
618180	Relay (#282062 & #282066 Compressor)	2
718794	Switch - High Pressure Cutout	2
778027	Wrench - Allen (Cab)	2
2117987	Pulley - Drive Motor (Soft Serve)	1
2147034	Pulley - Speed Reducer (Soft Serve)	1
2156534	Pulley - Drive Motor (Soft Serve) (50 Hz)	1
2187684	Bracket - Mix Tube Support (Cab)	1

8.15 REAR (CONTINUED)

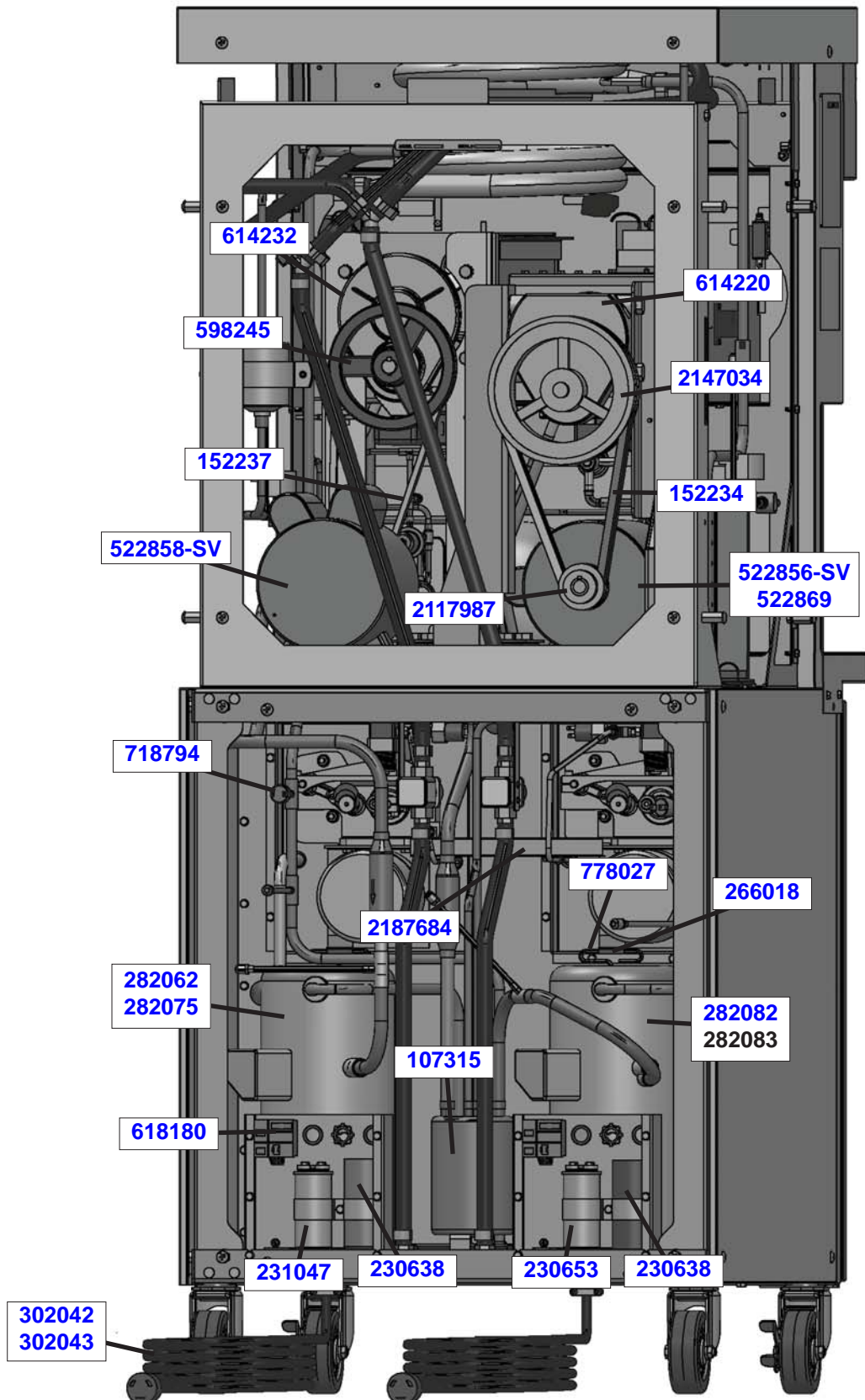

## 8.16 LEFT SIDE AND CABINET REFRIGERATION SYSTEM

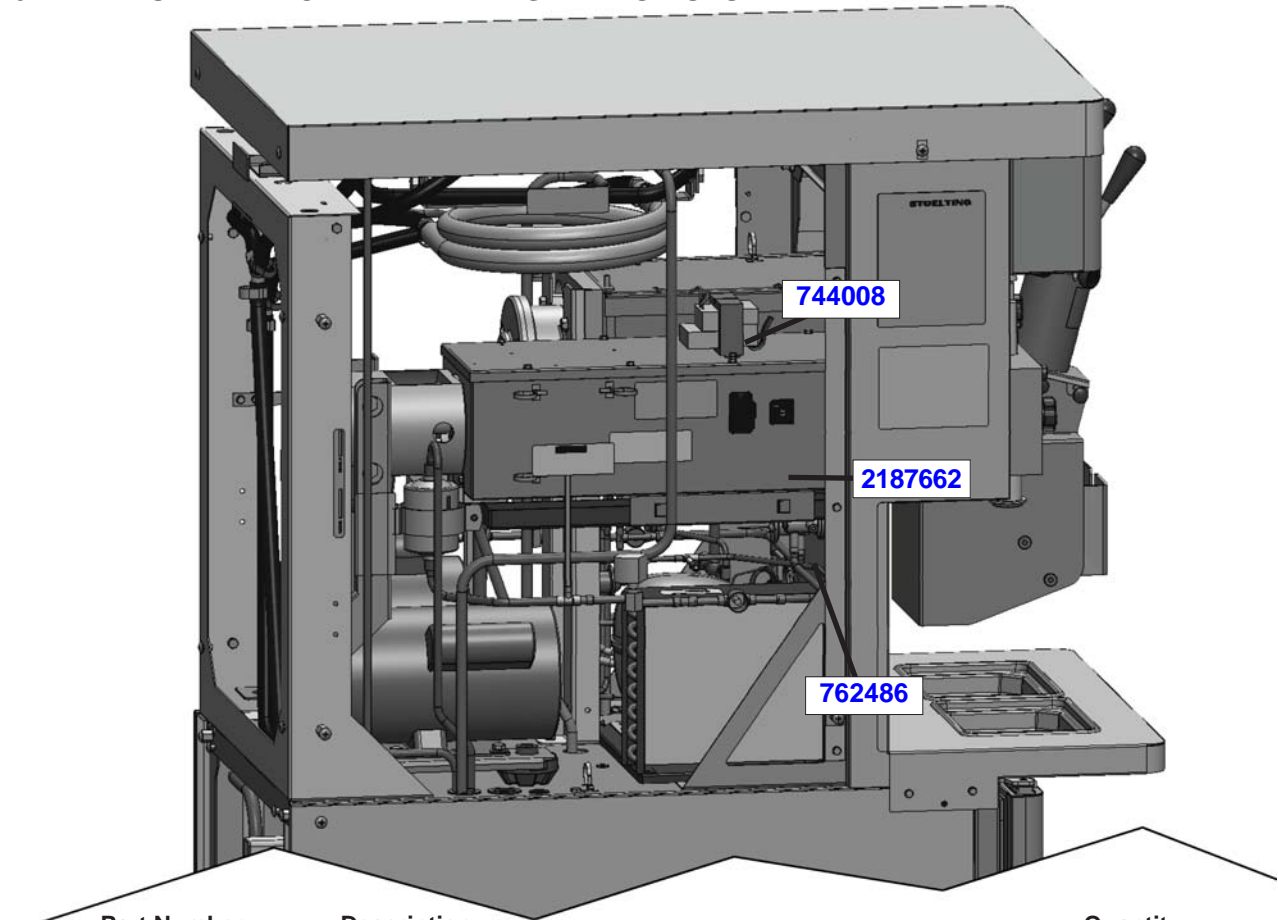

Part Number	Description	Quantity
618231	Relay - Overload (#522869 3 PH Drive Motor)	1
743654	Transformer - Booster (Shake)	1
744008	Transformer (Soft Serve)	1
762486	Valve - Expansion (Soft Serve)	1
2187662	Evaporator Assembly (Shake)	1

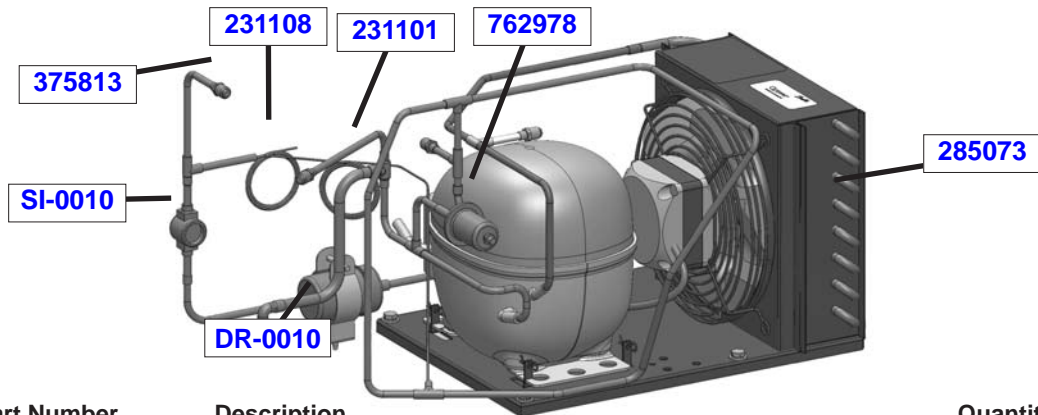

Part Number	Description	Quantity
DR-0010	Drier - Filter (1/4" OD) (Cab Condenser)	1
SI-0010	Sight Glass (Cab Condenser)	1
231101	Cap Tube Only - Mix Line Tubing (Cab Condenser)	1
231108	Cap Tube Only - Cab Evaporator (Cab Condenser)	1
285073	Condenser (Cab)	1
368448	Filter - Ari (Cab Condenser)	1
375813	Access Valve Fitting (Cab Condenser)	1
718686	Switch - Pressure (High Pressure Cutout) (Cab Condenser)	1
762978	Valve - EPR (Cab Condenser)	1



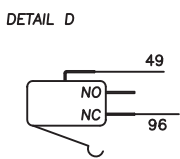
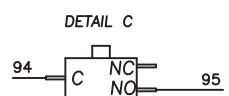
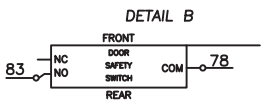
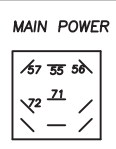
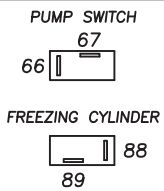
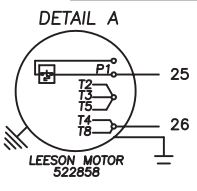
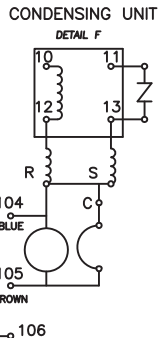
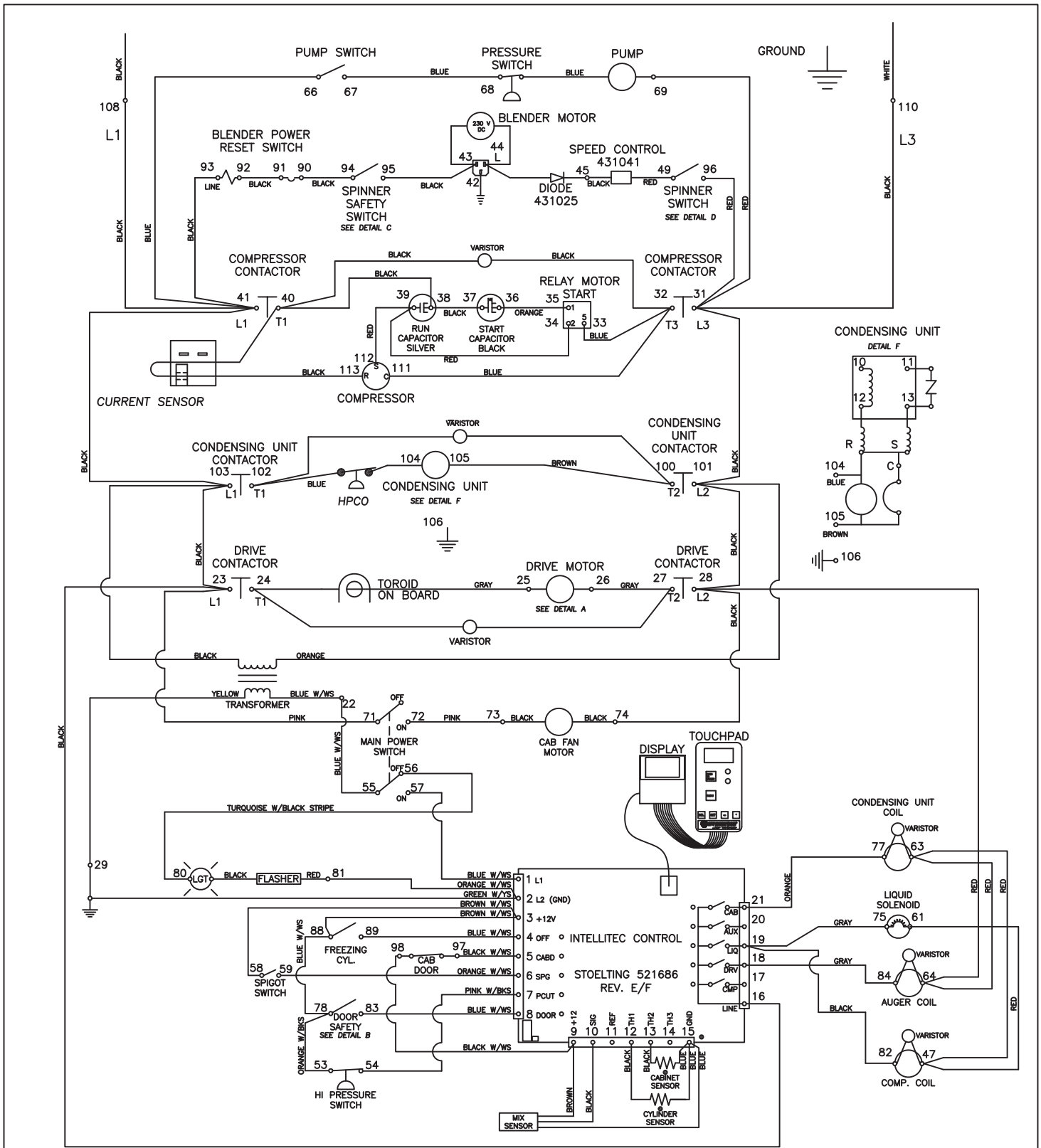

NOTE :  
 LEFT SIDE COMPRESSOR WIRE MUST PASS THROUGH CURRENT SENSOR (2)  
 TIMES AND RIGHT SIDE COMPRESSOR WIRE MUST PASS THROUGH (1) TIME.



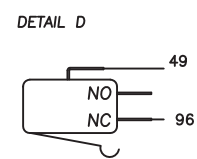
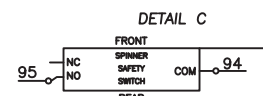
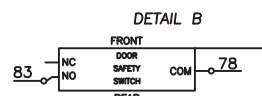
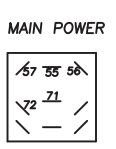
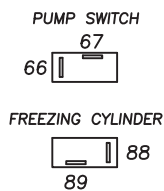
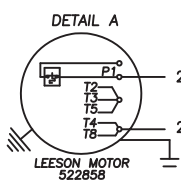
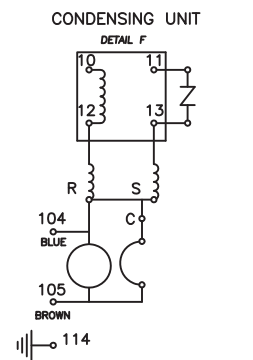
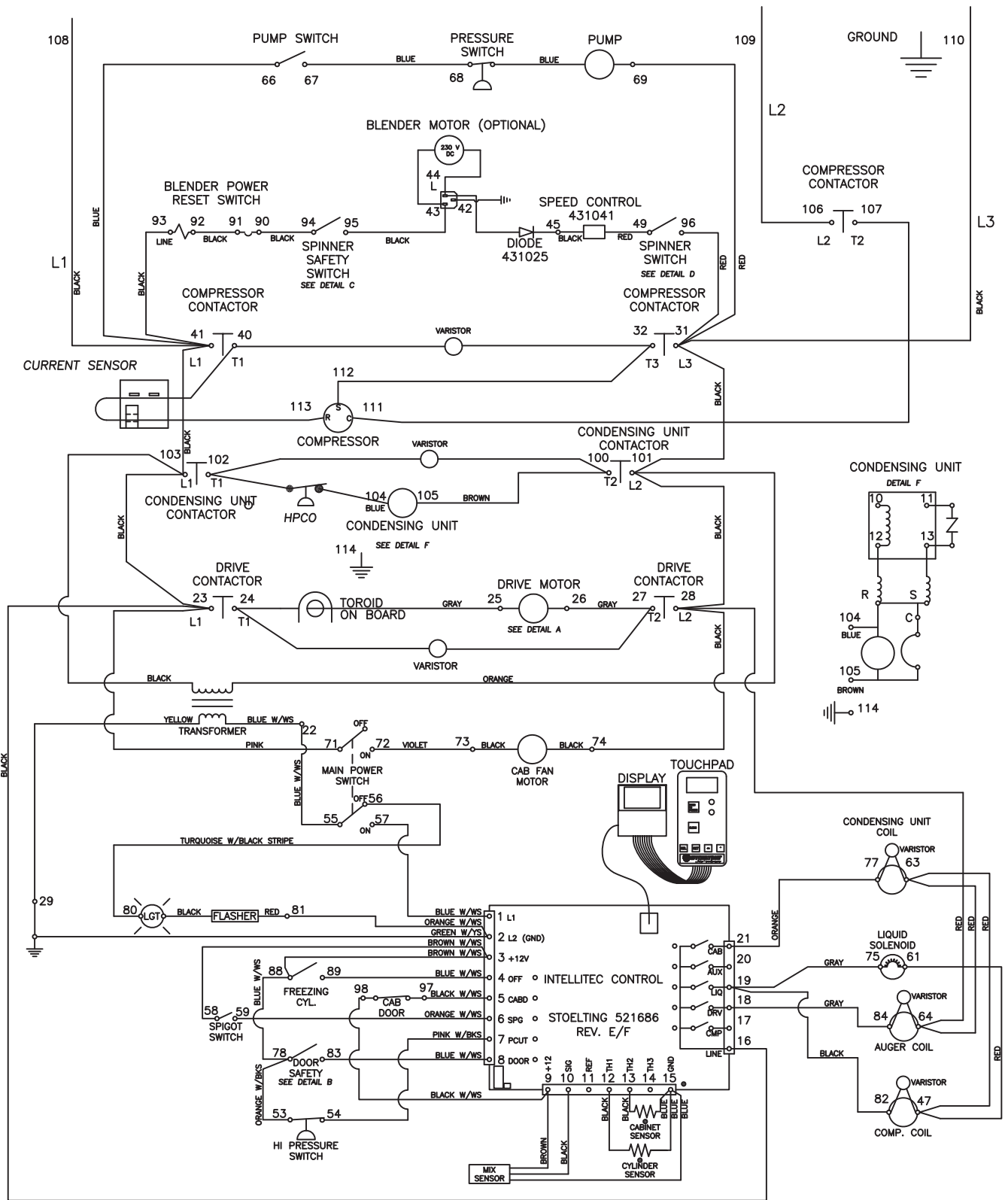

NOTE :  
FOR 3 PHASE ROUTE "RUN" WIRE THROUGH CURRENT SENSOR.