

**IMPORTANT FOR FUTURE REFERENCE**

Please complete this information and retain this manual for the life of the equipment:

Model #: \_\_\_\_\_

Serial #: \_\_\_\_\_

Date Purchased: \_\_\_\_\_

**Owner's Manual**

**StratoSteam**  
**Countertop Steamer**  
Models STRE-3D and STRE-5D

*STRATOSteam*

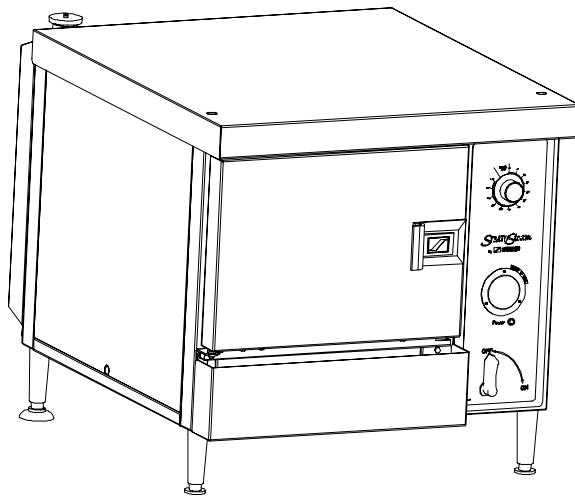

Model STRE-3D

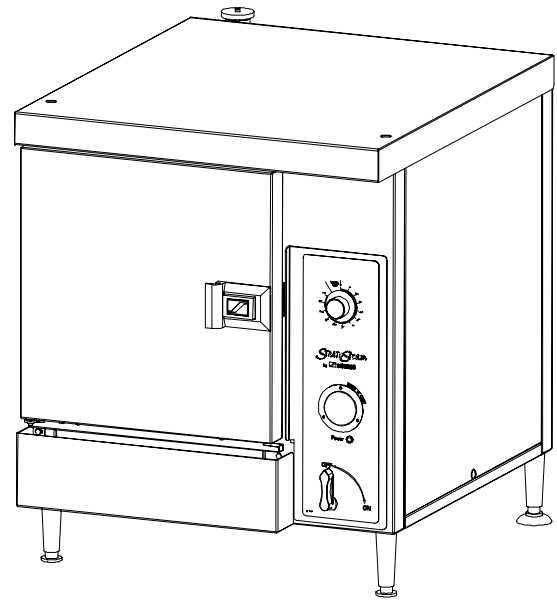

Model STRE-5D

**⚠ WARNING**

Improper installation, adjustment, alteration, service, or maintenance can cause property damage, injury, or death. Read installation, operation, and maintenance instructions thoroughly before installing or servicing this equipment.

1100 Old Honeycutt Road, Fuquay-Varina, NC 27526 USA • [www.southbendnc.com](http://www.southbendnc.com)

# SAFETY PRECAUTIONS

Before installing and operating this equipment, be sure everyone involved in its operation is fully trained and aware of precautions. Accidents and problems can be caused by failure to follow fundamental rules and precautions.

The following symbols, found throughout this manual, alert you to potentially dangerous conditions to the operator, service personnel, or to the equipment.



**DANGER**

This symbol warns of immediate hazards that will result in severe injury or death.



**WARNING**

This symbol refers to a potential hazard or unsafe practice that could result in injury or death.



**CAUTION**

This symbol refers to a potential hazard or unsafe practice that could result in injury, product damage, or property damage.



**NOTICE**

This symbol refers to information that needs special attention or must be fully understood, even though not dangerous.

 **WARNING**  
**FIRE HAZARD**  
**FOR YOUR SAFETY**

Do not store or use gasoline or other flammable vapors and liquids in the vicinity of cooking appliances. Keep area around cooking appliances free and clear of combustibles.

 **WARNING**  
**BURN HAZARD**

Contact with hot surfaces will cause severe burns. Always use caution when operating cooking appliances. Stand back when opening the steamer door as hot steam or hot water may escape from the door opening. Hot steam or hot water will flow out the drain located at the right rear bottom corner of the steamer. Hot steam may escape from the pressure relief valve located at the top left rear corner of the steamer.

 **WARNING**  
**ELECTRIC SHOCK HAZARD**

Disconnect the power to the appliance before cleaning. Do not remove panels that require tools to remove.

**NOTICE**

Southbend appliances are intended for commercial use only. Not for household use.  
Warranty will be void if service work is performed by other than a qualified technician, or if other than genuine Southbend replacement parts are installed.  
Give this Owner's Manual and important papers to the proper authority to retain for future reference.

Copyright © 2004 by Southbend. All rights reserved. Published in the United States of America.

# INTRODUCTION

Congratulations! You have purchased one of the finest pieces of heavy-duty commercial cooking equipment on the market.

You will find that your new equipment, like all Southbend equipment, has been designed and manufactured to meet the toughest standards in the industry. Each piece of Southbend equipment is carefully engineered and designs are verified through laboratory tests and field installations. With proper care and field maintenance, you will experience years of reliable, trouble-free operation. For best results, read this manual carefully.

RETAIN THIS MANUAL FOR FUTURE REFERENCE.

This manual is for Southbend StratoSteam Countertop Steamer models STRE-3D and STRE-5D. The manual is divided into six sections:

- Introduction ..... 3
- Specifications..... 4
- Operation ..... 7
- Cleaning & Maintenance..... 10
- Installation..... 12
- Service ..... 19

Each steamer has two serial plates located on the exterior of the steamer (see Figure 1 below).

Read these instructions carefully before attempting installation. Installation and initial startup should be performed by a qualified installer. Unless the installation instructions for this product are followed by a qualified service technician (a person experienced in and knowledgeable with the installation of commercial gas and/or electric cooking equipment) then the terms and conditions on the Manufacturer’s Limited Warranty will be rendered void and no warranty of any kind shall apply.

In the event you have questions concerning the installation, use, care, or service of the product, write to:

Southbend  
1100 Old Honeycutt Road  
Fuquay-Varina, North Carolina 27526 USA

Figure 1

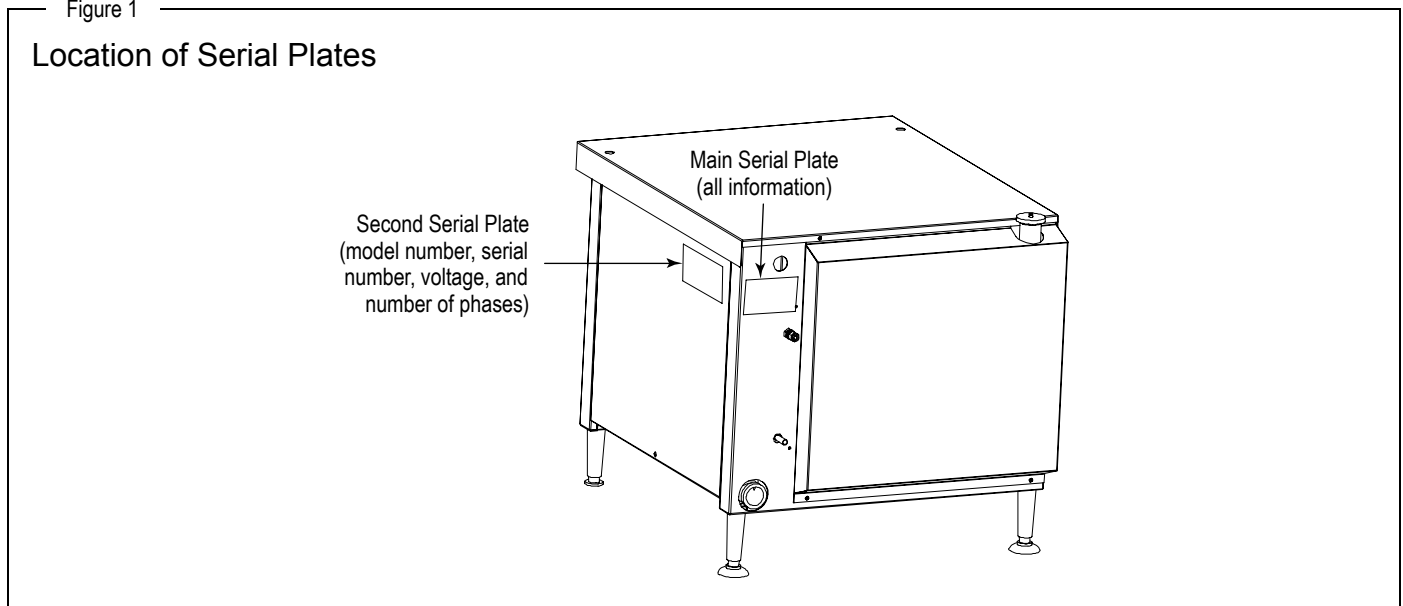

# SPECIFICATIONS

## NOTICE

Local codes regarding installation vary greatly from one area to another. The National Fire Protection Association, Inc., states in its NFPA 96 latest edition that local codes are the “authority having jurisdiction” when it comes to installation requirements for equipment. Therefore, installations should comply with all local codes.

The steamer, when installed, must be electrically grounded and comply with local codes, or in the absence of local codes with the *National Electrical Code ANSI/NFPA 70-latest edition*.

Canadian installations must comply with *CSA-Standard (C22.2 No. 109-M1981 General Requirements-Canadian Electrical Code, Part II. 109-M1981) Commercial Cooking Appliances*.

Southbend reserves the right to change specifications and product design without notice. Such revisions do not entitle the buyer to corresponding changes, additions, or replacements for previously purchased equipment.

This product is intended for commercial use only, not for household use.

## CLEARANCES

### WARNING

#### MINIMUM CLEARANCES FROM COMBUSTIBLE CONSTRUCTION

Minimum clearance from combustible and non-combustible surfaces is 0" on the sides, bottom, and top; and 4" on the rear. Adequate clearance must be provided in the aisle in front of the steamer to permit operation (including pulling out of pans).

Steam may escape from the pressure relief valve at the top left rear corner of each steamer, and from the door opening when the door is opened. Installation under a vented hood is recommended.

A steamer may be installed on combustible and non-combustible countertops.

## DIMENSIONS

The dimensions of the steamer are shown in Figure 2 on the next page. The following table lists the interior dimensions and the crate dimensions and weight.

Model	Interior Dimensions			Pan Capacity*			Crate Dimensions				Crated Weight
	Width	Depth	Height	1"	2.5"	4"	Width	Depth	Height	Volume	
STRE-3D	13-1/2" (343)	24" (610)	10-5/8" (270)	6	3	2	52" (1321)	43" (1092)	40" (1016)	51.8 cu. ft. 1.47 cu. m.	216 lbs. 98 kg.
STRE-5D	13-1/2" (343)	24" (610)	15-5/8" (397)	11	5	3	52" (1321)	43" (1092)	40" (1016)	51.8 cu. ft. 1.47 cu. m.	238 lbs. 108 kg.

\* "Pan Capacity" is the number of 1", 2.5", or 4" high standard pans (12" wide x 20" front-to-back) that the steamer will hold.

Figure 2

Dimensions

Dimensions shown in inches and (millimeters)

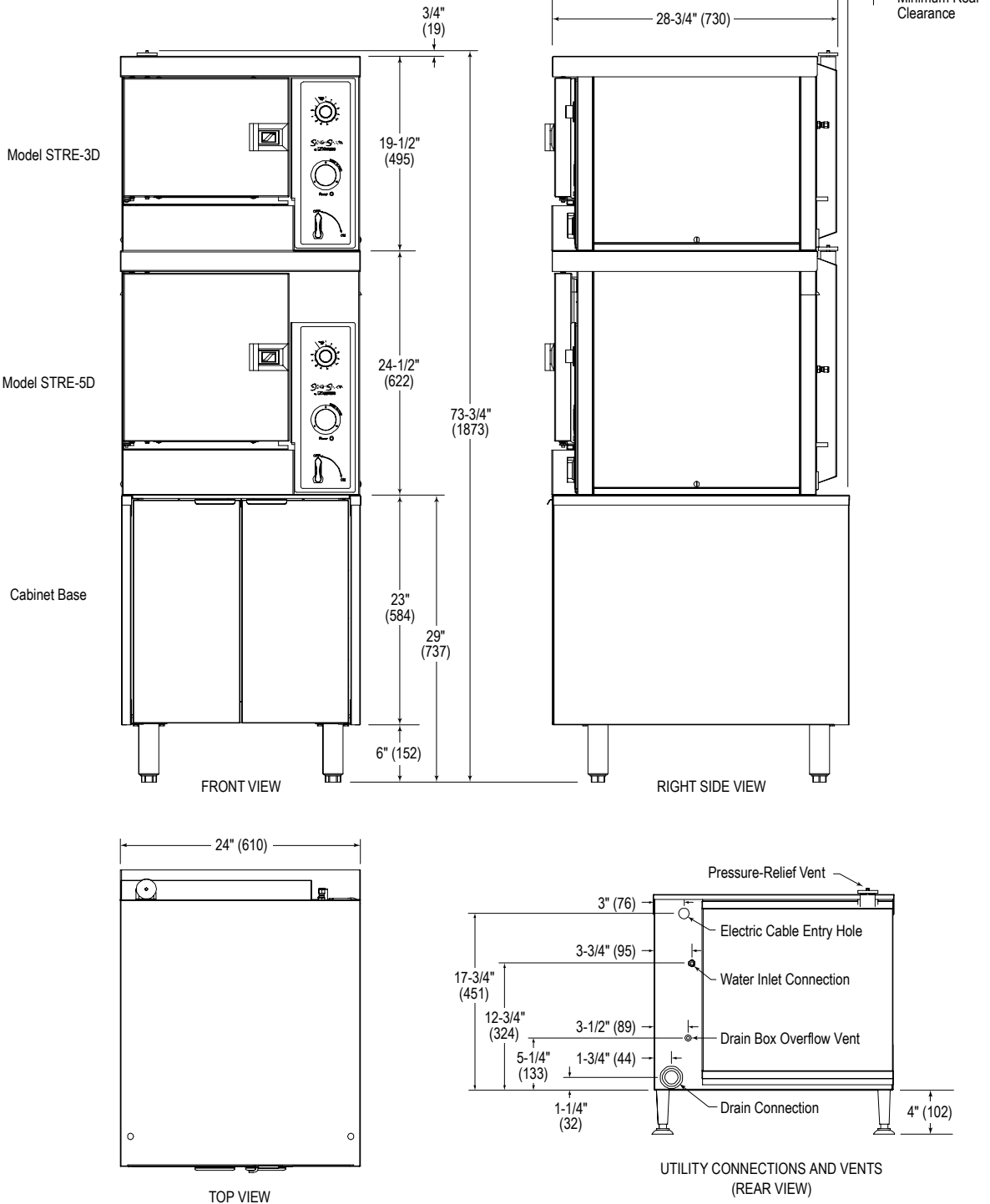

## ELECTRICAL REQUIREMENTS

One fused electrical connection is required to the contactor of each steamer. All steamers are shipped per customer order, three phase or single phase. (A kit is available for field conversion to three phase or single phase.) The fused connection must be wired for the required voltage and maximum amperage as listed in the chart below:

Voltage	Total Connected Amps			
	Model STRE-3D		Model STRE-5D	
	1 Phase	3 Phase	1 Phase	3 Phase
208 V 60 Hz	44	26	53	31
220 V 50/60 Hz	41	24	51	29
240 V 60 Hz	38	22	46	27
480 V 60 Hz	19	11	23	14

## WATER REQUIREMENTS

To meet warranty requirements, the water supply must be as follows:

Connection	1/4" compression, cold water
Pressure	30 to 60 PSI
Total Dissolved Solids (TDS)	60 PPM or less
Hardness	2 grains (35 PPM) or less
pH	7.0 to 7.5
Maximum Fill Capacity	0.87 gallons

Typical usage is 0.46 gallons per minute at 45 PSI.

In order to minimize service problems and to meet the warranty requirements, a water treatment system (softener) is recommended when water quality does not meet the limits stated above.

## DRAIN REQUIREMENTS

The drain outlet has a 1" NPT female connector. Do NOT directly connect the drain to a plumbing system unless you also install an "open funnel" downstream of this connection (see Figure 7 on page 16). There must be no back-flow or back-pressure into the drain connection!

# OPERATION

## NOTICE: WATER SPECIFICATION

To meet warranty requirements, supply water must meet the following specification:

Total Dissolved Solids (TDS).....60 PPM or less  
 Hardness.....2 Grains (35 PPM) or less  
 pH Factor .....7.0 to 7.5

## STARTUP

Turn control lever to “ON” position (see Figure 3). The steamer will fill automatically and be ready for cooking in about four minutes.

## OPERATION

### CAUTION

HOT STEAM WILL ESCAPE WHEN DOOR IS BEING OPENED. TO PREVENT BURNS KEEP HANDS AND FACE AWAY FROM STEAM.

When turned ON, the steamer operates continuously. To save water and electricity, turn the control lever to OFF when the steamer is not in use.

Suggested cooking times for various foods are shown in the table in the following section.

Pan specifications are shown on page 4.

The door may be opened or closed at any time. The steamer temporarily shuts off while the door is open.

Timer can be used as a reminder to the operator. The timer does NOT turn the steamer on or off!

## SHUTDOWN

Turn lever to the “OFF” position. The water in the bottom of the cavity will automatically drain.

## TROUBLESHOOTING BY OPERATOR

The following table lists the possible causes and solutions of problems that may occur during operation.

Problem	Possible Causes and Solutions
Steamer does not heat up at all.	<ul style="list-style-type: none"> <li>– Electric power is shut off. Turn on power.</li> <li>– Water supply is shut off. Turn on water.</li> <li>– Not enough water is entering steamer. Check water supply.</li> <li>– Lime build-up. De-lime steamer cavity (see page 10).</li> <li>– If water is OK and there is little lime build-up, call repair service.</li> </ul>
Steamer does heat up, but does not produce enough steam.	<ul style="list-style-type: none"> <li>– Door is open or ajar. Close steamer door completely.</li> <li>– Lime build-up. De-lime steamer cavity (see page 10).</li> <li>– Not enough water. Check water supply.</li> </ul>
Steamer does not drain correctly.	<ul style="list-style-type: none"> <li>– Clogged drain on inside of steamer cavity. Check and clear.</li> <li>– Clogged drain outside of steamer. Check and clear.</li> </ul>

Figure 3

Controls

**Timer**

Set for up to 60 minutes as a reminder to operator. DOES NOT CONTROL STEAMER. When buzzer sounds, turn knob counterclockwise to silence the buzzer.

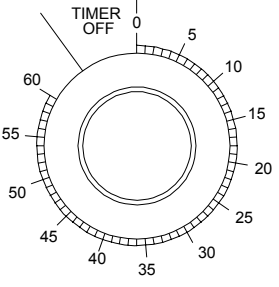

*STRATOSteam*

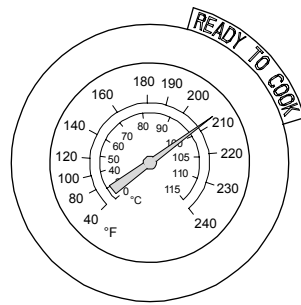

**Thermometer**

Indicates temperature in cooking cavity. Steamer is "ready to cook" when temperature reaches 190°F (88°C).



**Power Light**

Lights when the steamer has electric power and Control Lever is turned to ON.

**Control Lever**

Turn to ON to cook. Steamer will reach cooking temperature in about 4 minutes. Turn to OFF to shut down or to conserve water and electricity during idle periods.

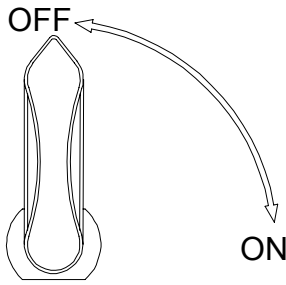

**COOKING TIPS**

- Schedule cooking of fresh vegetables so that they will be served soon after they are cooked. If it is necessary to prepare them in advance, they can be plunged into cold water, drained thoroughly and held under refrigeration until needed for service. Five pounds of cold cooked vegetables can be reheated in the steamer in 5 to 10 minutes, depending upon the variety.

- To avoid green yolk (which is a deposit of iron sulfide) chill the eggs immediately after removing from the steamer by plunging them into a cold water bath (preferably containing ice).
- A quick and easy way to cook eggs for a salad mixture is to crack them directly into a solid steam table pan which has been lightly coated with salad oil. Do not mix. Steam until they are hard cooked. Remove and chop as you would for egg salad. The job of peeling is eliminated.
- Chicken, sausage, and/or fish may be browned in an infra-red or radiant broiler after steaming by brushing with melted margarine mixed with salad oil to give a golden brown color.
- Save juices from steamed meat and poultry to make soups, sauces, or casserole dishes.
- Chicken may be steamed in advance and then refrigerated. Bring food back to 180°F before serving.
- Steaming brisket is a definite time saver. Boiling in water takes 40 to 50 minutes per pound. Using the steamer can save 50% in cooking time.
- Steamed cabbage retains its color and wedge identity. It will not break apart as it does when boiled.
- When removing items prepared in a perforated pan, place a solid pan underneath the perforated pan with the cooked food in order to prevent dripping on the floor.
- The steamer is designed to accept standard 12" x 20" pans. Fractional size pans and dishes can be used as well with a perforated shelf.
- For stirring, the pan does not have to be removed from the steamer. Pull pan 1/3 way out of the cavity and the entire surface is accessible.
- The door may be opened at any time during operation to remove or add food. While the door is open, the steamer will stop producing steam.

## SUGGESTED COOKING TIMES

These cooking times are for general guidance only. Differences in food quality, size, shape, thickness, freshness, load size, and desired degree of doneness must be taken into consideration and adjustments made in time, if necessary.

Product	Quantity	STRE-3D Cooking Time (minutes)	STRE-5D Cooking Time (minutes)
Eggs	18	5	6
	48	6	7
Potatoes, Red	4 lbs.	18	18
	8 lbs.	18	18
Rice	2 lbs.	15	16
	3 lbs.	15	17
Shrimp, Frozen	2.5 lbs.	4.5	4
	8 lbs.	8	7
Corn, Frozen	2.5 lbs.	3	2.5
	7.5 lbs.	5	4.5
Peas, Frozen	5 lbs.	5.5	4
	12 lbs.	10	8
Mixed Vegetables, Frozen	2.5 lbs.	4	3.25
	8 lbs.	6.5	5.5
	15 lbs. (3 full pans)	14	-
	25 lbs. (5 full pans)	-	17
Salmon Filets, Frozen, 4.5 oz.	1 piece	7	7
	8 pieces	7	7
Salmon Filets, Frozen, 6 oz.	8 pieces	12	10
	18 pieces (3 full pans)	17	-
	30 pieces (5 full pans)	-	15
Lasagna, 6 lb., Frozen	1	65	60
	3	65	-
	5	-	60
Cake, White, 5 lb. Mix	1 pan	30	25

# CLEANING & MAINTENANCE

## **WARNING**

Shut off the steamer before cleaning or performing maintenance.

Southbend appliances are sturdily constructed of the best materials and are designed to provide durable service when treated with ordinary care. To expect the best performance, your equipment must be maintained in good condition and cleaned daily. Naturally, the periods for this care and cleaning depend on the amount and degree of usage.

*Following daily and periodic maintenance procedures will enhance long life for your equipment. Climatic conditions (such as salt air) may require more thorough and frequent cleaning or the life of the equipment could be adversely affected.*

Keep exposed, cleanable areas clean at all times.

## DAILY CLEANING AND MAINTENANCE

### **NOTICE**

DO NOT USE high-chlorine or bleach solution for cleaning the door gasket.

DO NOT USE steel wool or other metallic pads in the steamer.

1. Turn control lever to "OFF" and allow time for the steamer to drain and cool.
2. Remove and clean pans.
3. Remove and clean pan supports and cavity bottom cover. Wash separately in a sink with a mild detergent and warm water. Dry thoroughly with a clean cloth. Non-metallic scouring pads may be used to remove cooked-on deposits.
4. Clean all interior surfaces with mild detergent, warm water, and a non-metallic pad. If discoloration of surfaces starts due to buildup of seasonings or food products, remove them using a non-metallic scouring pad. **RINSE THOROUGHLY WITH CLEAN WATER.** Dry thoroughly with a clean cloth.
5. Ensure drain opening inside of cavity is clear.
6. Clean drain opening.
7. Place cleaned cavity bottom cover, pan supports, and pans back into their correct positions.
8. Leave the door open at night after cleaning to allow complete drying and to prolong the life of the door gasket.

## PERIODIC DE-LIMING (AS NEEDED)

If lime or mineral deposits start to buildup on the cavity interior, they should be removed with a non-caustic de-liming solution such as Lime-A-Way®. Follow the manufacturer's instructions for use of the de-liming solution.

## STAINLESS-STEEL SURFACES

To remove normal dirt, grease and product residue from stainless steel surfaces that operate at LOW temperature, use ordinary soap and water (with or without detergent) applied with a sponge or cloth. Dry thoroughly with a clean cloth.

To remove BAKED-ON grease and food splatter, or condensed vapors; apply cleanser to a damp cloth or sponge and rub cleanser on the metal in the direction of the polishing lines on the metal. Rubbing cleanser, as gently as possible, in the direction of the polished lines will not mar the finish of the stainless steel. **NEVER RUB WITH A CIRCULAR MOTION.** Soil and burnt deposits which do not respond to the above procedure can usually be removed by rubbing the surface with SCOTCH-BRITE scouring pads or STAINLESS scouring pads. **DO NOT USE ORDINARY STEEL WOOL** as any particles left on the surface will rust and further spoil the appearance of the finish. **NEVER USE A WIRE BRUSH, STEEL SCOURING PADS (EXCEPT STAINLESS), SCRAPER, FILE OR OTHER STEEL TOOLS.**

Surfaces which are marred collect dirt more rapidly and become more difficult to clean. Marring also increases the possibility of corrosive attack. Refinishing may then be required.

“Heat tint” is darkened areas that sometimes appear on stainless steel surfaces where the area has been subjected to excessive heat. These darkened areas are caused by thickening of the protective surface of the stainless steel and are not harmful. Heat tint can normally be removed by the foregoing, but tint which does not respond to this procedure calls for a vigorous scouring in the direction of the polish lines using SCOTCH-BRITE scouring pads or a STAINLESS scouring pad in combination with a powered cleanser.

# INSTALLATION

## CAUTION

Do not locate steamer adjacent to any high heat or grease producing piece of equipment, such as a range top, griddle, fryer, etc., that could allow radiant heat to raise the exterior temperature of the steamer body above 130°F (54°C). DO NOT MOUNT ABOVE OTHER COOKING EQUIPMENT.

## NOTICE

These installation procedures must be followed by qualified personnel or warranty will be void.

Local codes regarding installation vary greatly from one area to another. The National Fire Protection Association, Inc., states in its NFPA 96 latest edition that local codes are the “authority having jurisdiction” when it comes to installation requirements for equipment. Therefore, installations should comply with all local codes.

The steamer, when installed, must be electrically grounded and comply with local codes, or in the absence of local codes with the *National Electrical Code ANSI/NFPA 70-latest edition*.

Canadian installations must comply with *CSA-Standard (C22.2 No. 109-M1981 General Requirements-Canadian Electrical Code, Part II. 109-M1981) Commercial Cooking Appliances*.

## NOTICE

**EXHAUST FANS AND CANOPIES:** It is recommended that the steamer be installed under a ventilation hood. Consult local codes for proper installation of hoods. Proper ventilation is the owner’s responsibility. Any problem due to improper ventilation will not be covered by warranty.

**LEVELING:** Steamer must be level for proper operation. Improper leveling may void the warranty.

## STEP 1: UNPACKING

### IMMEDIATELY INSPECT FOR SHIPPING DAMAGE

All containers should be examined for damage before and during unloading. The freight carrier has assumed responsibility for its safe transit and delivery. If damaged equipment is received, either apparent or concealed, a claim must be made with the delivering carrier.

Apparent damage or loss must be noted on the freight bill at the time of delivery. The freight bill must then be signed by the carrier representative (Driver). If the bill is not signed, the carrier may refuse the claim. The carrier can supply the necessary forms.

A request for inspection must be made to the carrier within 15 days if there is concealed damage or loss that is not apparent until after the equipment is uncrated. The carrier should arrange an inspection. Be certain to hold all contents plus all packing material.

Do the following:

1. Cut the banding straps and remove the corrugated cardboard surrounding the steamer. If legs were shipped in the same container, set them aside for installation in later steps of this procedure. Do not remove any tags or labels attached to the steamer until the steamer is installed and working properly.
2. If the steamer was shipped on a wooden skid, cut the banding strap holding the steamer to the wooden skid, unbolt the shipping hold-down brackets from the skid, then remove the brackets from the steamer.
3. If the steamer is to be installed on legs, go to Step 2a.  
If the steamer is to be installed without legs on a countertop, go to Step 2b.  
If the steamer is to be mounted on the optional cabinet base, go to Step 2c.  
If two steamers are to be stacked, go to Step 2d.

## STEP 2A: ATTACH LEGS

A set of four legs is packed with steamers ordered with legs.

A threaded hole is located at each corner. Each leg has a corresponding mating thread. The legs can be adjusted to overcome a slightly uneven surface.

1. Raise the steamer sufficiently to allow the legs to be attached. For safety, “shore up” and support the steamer with an adequate blocking arrangement strong enough to support the load.
2. Screw the legs into the holes (see Figure 4). **Note that the front legs are different than the rear legs.**
3. Lower the steamer gently onto a level surface. Never drop or allow the steamer to fall.
4. Make sure that the steamer is level (both side-to-side and front-to-back). If necessary, adjust the height of each leg by turning the foot-pad of the leg.
5. Go on to Installation Step 3.

Figure 4

### Attach Legs

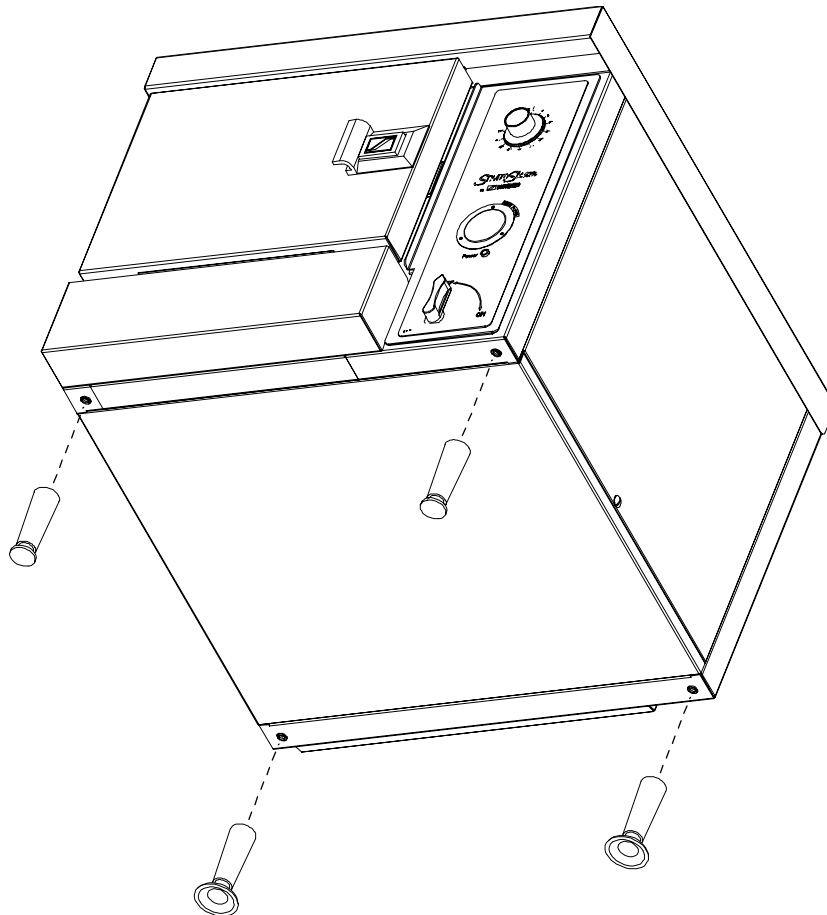

## STEP 2B: ATTACH TO COUNTERTOP

If the steamer is to be installed on a countertop or other surface without using legs, the steamer must be sealed to the surface to prevent any water, grease, etc., from accumulating under the steamer. The steamer can be bolted to the surface, but will still have to be sealed. Make sure that the installed steamer is level before applying the sealant. The installer may use GE® or Dow Corning® RTV type sealant. Consult local code for exact requirements.

1. Lower the steamer gently onto a level surface. Never drop or allow the steamer to fall.
2. If desired, bolt the steamer to the surface (use 3/8-16 bolts to fit the threaded holes used by the legs).
3. Make sure that the steamer is level (both side-to-side and front-to-back).
4. Apply sealant around all four bottom edges of the steamer (see Figure 5).
5. Go on to Installation Step 3.

Figure 5

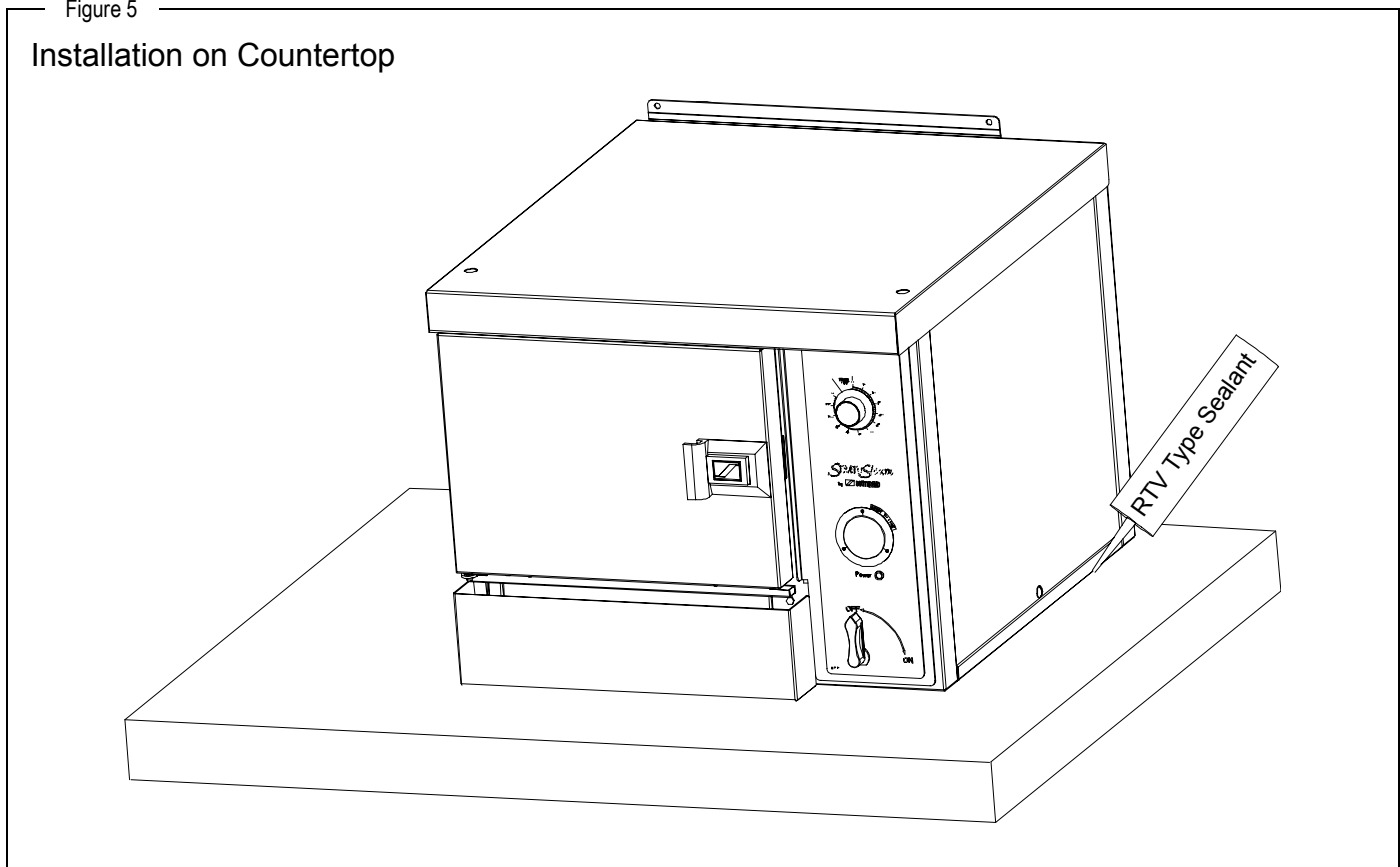

## STEP 2C: MOUNTING ON CABINET BASE

If the steamer is to be mounted on the optional cabinet base, first attached the legs to the cabinet base (if not already attached). Then place the steamer on top of the cabinet base and line up the threaded holes on the bottom of the steamer with the holes in the cabinet-base top. Secure the steamer to the base with four 3/8-16 bolts. Go on to Installation Step 3.

## STEP 2D: STACKING TWO STEAMERS

If two steamers are to be stacked, mount the lower steamer first on either legs (Step 2a), a countertop (Step 2b), or the optional cabinet base (Step 2c). Remove (if present) the four chrome-plated plugs from the holes in the top panel of the lower steamer. Place the upper steamer on top of the lower steamer and line up the threaded holes on the bottom of the upper steamer with the holes in the top of the lower steamer. Secure the upper steamer to the lower steamer with four 3/8-16 bolts. The remaining steps of the installation must be performed for both steamers (they do not share any connections internally).

Figure 6

### Location of Connections and Vents

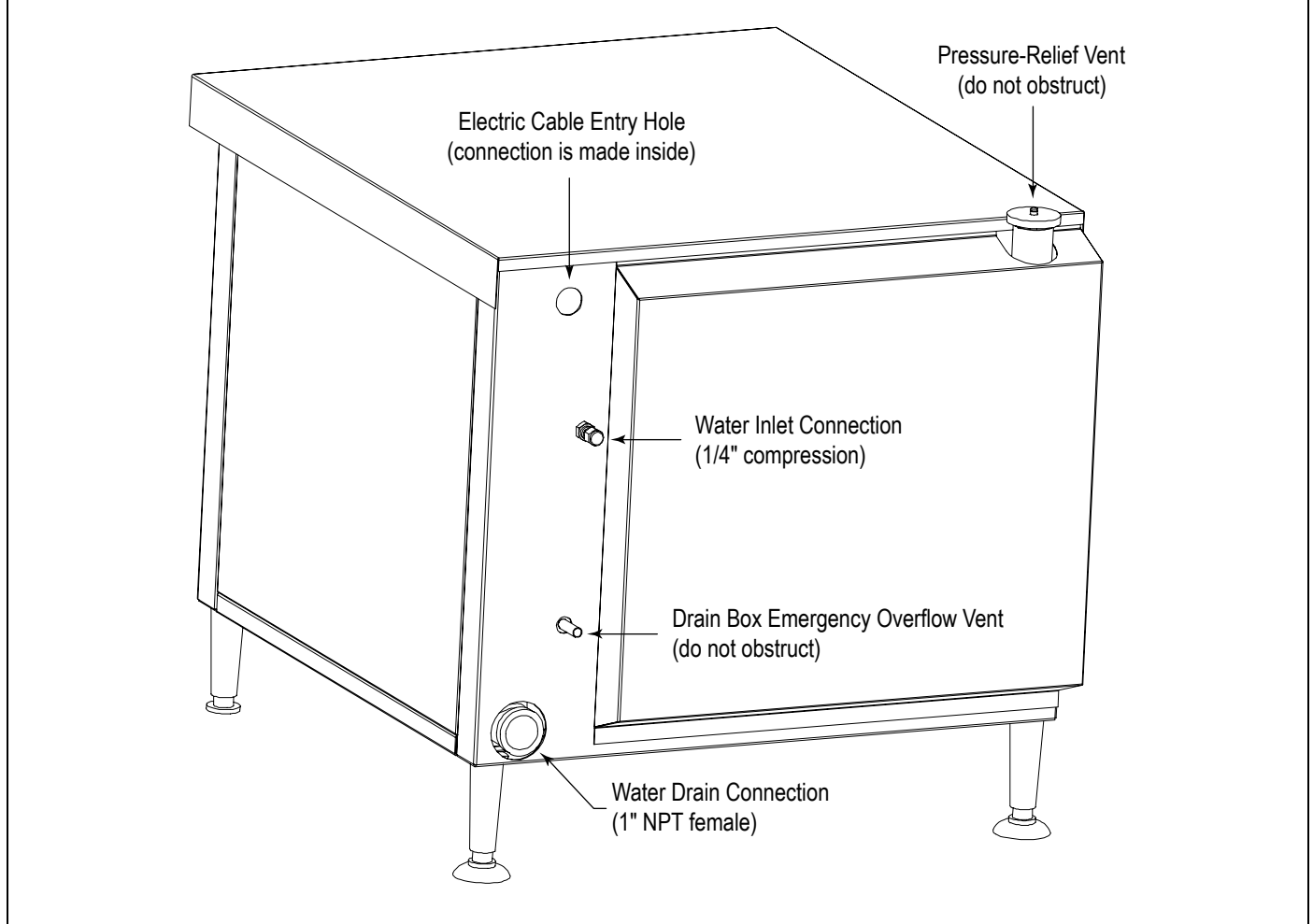

### STEP 3: DRAIN CONNECTION

The drain outlet is located on the back of the steamer, as shown in Figure 6. The drain connector on the steamer is 1" (32 mm) NPT female.

Position the steamer near, but not on top of, an open floor drain. DO NOT directly plumb the steamer unless you also install an "open funnel" downstream of this connection in the drain system. Make the drain line from the steamer to the air gap above the "open funnel" as short as possible. There should be no horizontal piping between the steamer and the air gap above the open funnel. The open funnel is intended to eliminate any water from entering the steamer because of a blocked drain, and it also prevents any back pressure within the steamer cavity. Any connection that allows the build-up of back pressure in the steamer (such as a reduction in pipe size to a line smaller than 1", or more than one 90-degree angle in the line prior to the open funnel drain discharge point) may cause personal or property damage and will therefore void the warranty. The steamer is a pressureless, free-venting steam cooker and will not operate properly unless the drain line is short, at a steep angle, and open! See Figure 7 on the next page.

Figure 7

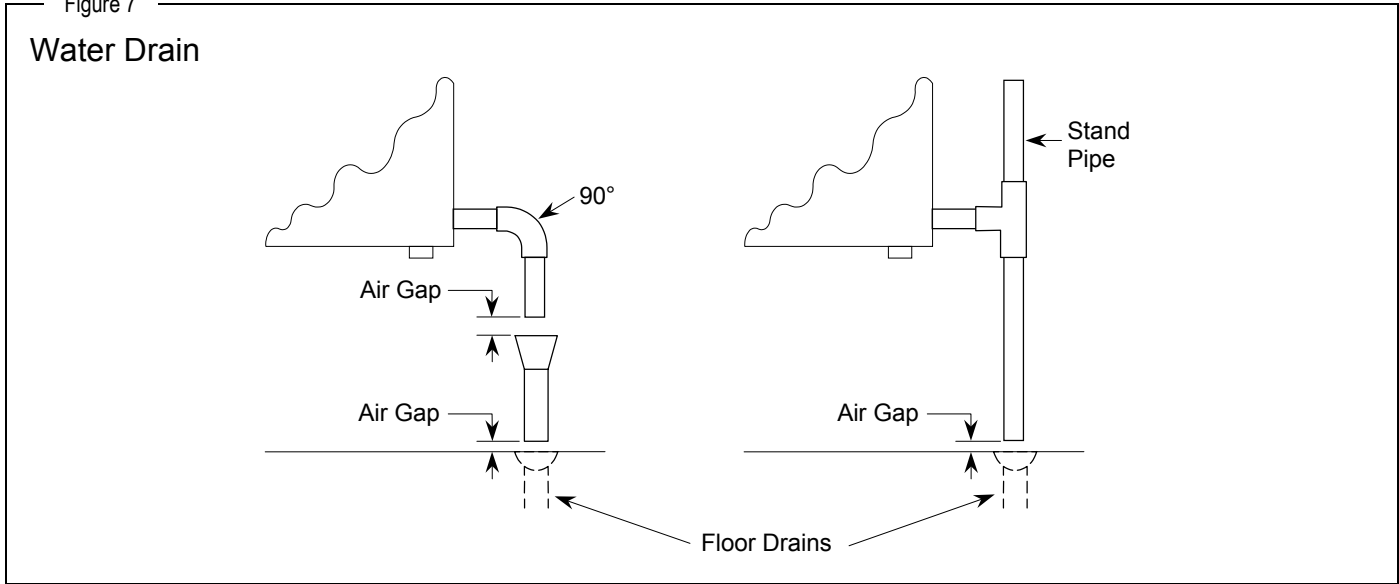

## STEP 4: WATER CONNECTION

### ⚠ WARNING

Do not connect steamer to a hot water line. A hot water connection will damage the steamer.

### NOTICE

To meet warranty requirements, the supply water must meet the following specifications:

Pressure	30 to 60 PSI (205 to 410 kPa)
Total Dissolved Solids (TDS)	60 PPM or less
Hardness	2 grains (35 PPM) or less
pH	7.0 to 7.5

Connect a cold water line to the water inlet strainer on the back of the steamer, as shown in Figure 6. The connector on the steamer is a 1/4" (6 mm) compression fitting.

NOTE: To facilitate cleaning, and allow access to rear of the steamer, flexible connections are recommended. A shut off valve at (or near) the rear of the steamer is highly recommended. Also, an accessible water filter is recommended to help keep water quality within the requirements described above. See Figure 8 below.

Figure 8

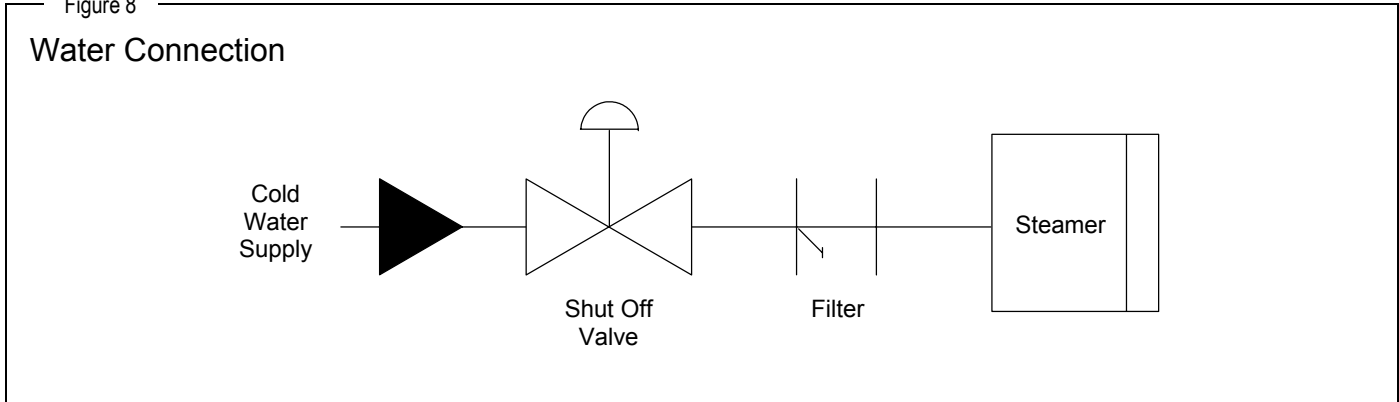

### STEP 5: ELECTRICAL CONNECTION

The electric connection is made to the contactor, which is located inside the service compartment on the right side of the steamer. The right side panel must be removed to gain access to the contactor. A hole on the rear of each steamer is provided for a 3/4" conduit fitting (solid or flex). An electric cable support bracket and clamp are located inside of the service compartment, to the right and above the contactor (see Figure 8).

Be sure that the input voltage and number of phases matches the requirement stated on the serial plate. The steamer is factory wired per customer order. A wiring diagram is attached to the inside of the right side panel of the steamer.

**⚠ WARNING**

A POSITIVE GROUND CONNECTION IS ESSENTIAL. DO NOT ALLOW ANY TAMPERING OR ADJUSTMENT OF ANY CONTROL OR WIRING. THE STEAMER IS FACTORY SET. ADJUSTING ANY INTERNAL COMPONENT CAN VOID THE WARRANTY.

THIS STEAMER REQUIRES A KIT TO BE FIELD CONVERTED FROM THREE-PHASE TO SINGLE-PHASE OR VICE-VERSA. CONSULT FACTORY FOR PHASE CHANGES.

For 3-wire 3-phase installations, connect wires L1, L2, and L3 to the three terminals on the upper end of the contactor. For 2-wire 1-phase installations, connect wires L1 and L2 to the two outer terminals on the upper end of the contactor.

Make the electrical ground connection to the ground lug located at the top right-hand corner of the contactor bracket.

Figure 9

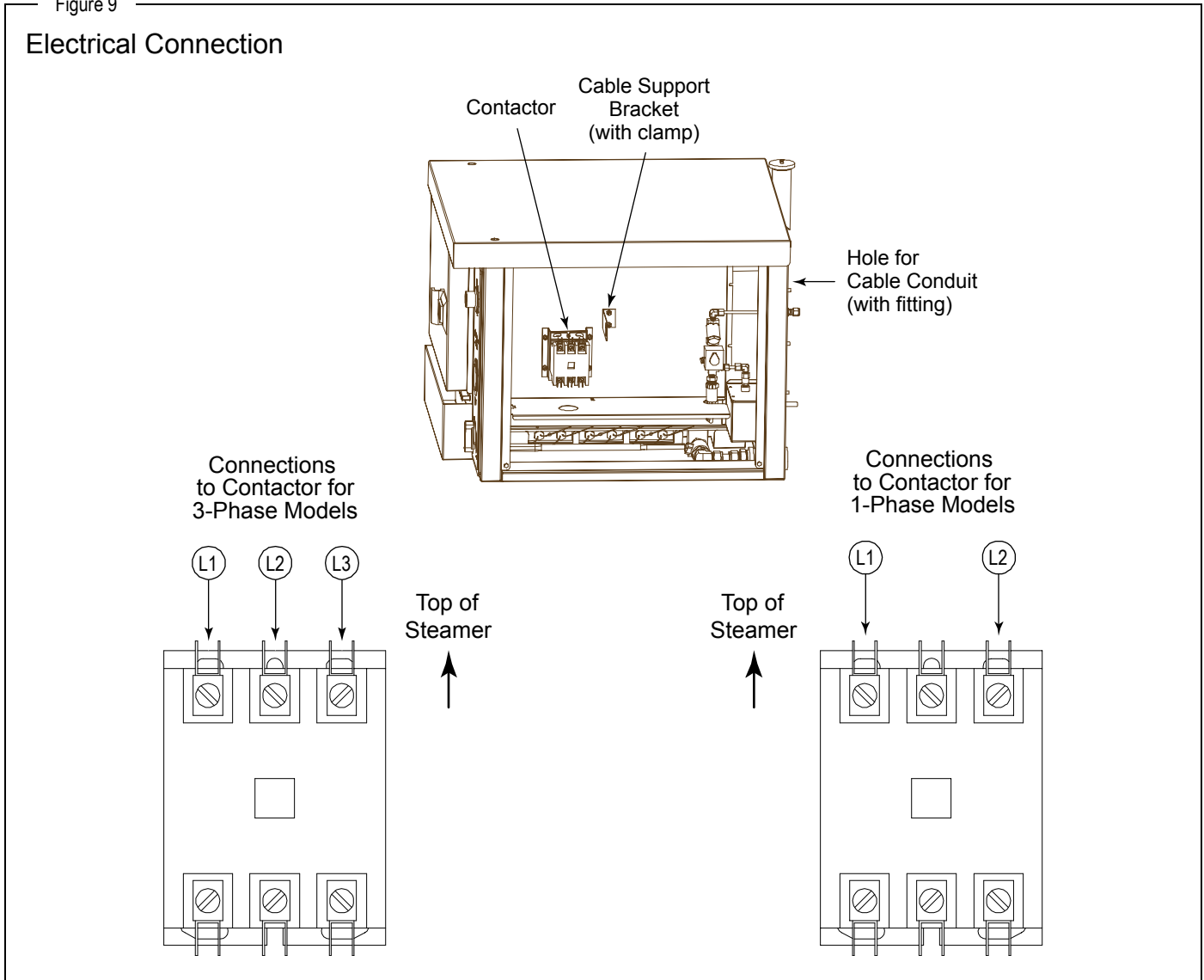

## STEP 6: CHECK THE INSTALLATION

Check the installation of each steamer, as follows:

1. Check that all screws and bolts are tightened.
2. Check that the electrical, water, and drain connections have been made correctly.
3. Check that the steamer is level. If not, adjust the legs (or level the countertop surface).
4. Check that the appropriate minimum clearances are satisfied (see page 4).
5. Check the door for proper alignment, and that it opens and closes properly.
6. Check that there is sufficient clearance in front of the steamer to open the door and to pull out the pans.
7. Wipe clean all surfaces.

## STEP 7: CHECK STEAMER OPERATION

Check the operation of each steamer, as follows:

1. Turn on the electric power supply and the water supply.
2. Move the ON/OFF lever to the "ON" position and check that the Power light comes on.
3. Check that the timer and buzzer operate correctly.
4. Open the door and check that water is entering the cavity (NOTE: the fill rate is slow).
5. Wait four minutes, then check that some water has covered the bottom of the cavity.
6. Depress the door-switch actuator rod and listen for an audible "click." Release the door-switch actuator rod and listen for another audible "click." (The clicks indicate that the contactor is functioning properly.)
7. Check that steam is escaping from the vent at the top left rear corner of the steamer.
8. Move the ON/OFF lever to the "OFF" position and check that the Power light goes out. Also check that the water is draining correctly into the drain, and that the steamer completely drains.

## STEP 8: SHUT-DOWN AND WIPE-CLEAN STEAMER

Complete the installation by leaving the steamer ready for customer use:

1. Allow the steamer to cool.
2. Wipe clean all surfaces.
3. Unless the steamer is to be placed in service immediately, turn off the electric power supply and water supply.
4. Make sure that a copy of this manual will be available to the people who will operate and maintain the steamer.

# SERVICE

## WARNING

ADJUSTMENTS AND SERVICE WORK MAY BE PERFORMED ONLY BY A QUALIFIED TECHNICIAN WHO IS EXPERIENCED IN, AND KNOWLEDGEABLE WITH, THE OPERATION OF COMMERCIAL COOKING EQUIPMENT. TO ASSURE YOUR CONFIDENCE, CONTACT YOUR AUTHORIZED SERVICE AGENCY FOR RELIABLE SERVICE, DEPENDABLE ADVICE OR OTHER ASSISTANCE, AND FOR GENUINE FACTORY PARTS.

## NOTICE

INSTALLATION OF OTHER THAN GENUINE SOUTHBEND PARTS WILL VOID THE WARRANTY ON THIS EQUIPMENT.

A serial plate is located on the right side of the steamer, near the top right corner. A second serial plate is located on the rear of the steamer near the top left corner (see Figure 1 on page 3).

Replacement parts (including parts not listed in this manual) may be ordered either through a Southbend Authorized Parts Distributor or a Southbend Authorized Service Agency.

When ordering parts, please supply the Model Number, Serial Number, Part Number, and Part Description.

This section contains troubleshooting flowcharts, procedures, and electric schematics to assist a qualified service technician in the servicing of a StratoSteam countertop steamer.

A description of how the steamer operates appears on the next page.

To remove a side panel (for access to the interior), remove the securing screw near the center of the bottom edge of the panel. To remove the top panel, remove the two securing screws on the rear face, then slide the top panel forward and off.

The door is field-reversible (contact Southbend for instructions).

## TROUBLESHOOTING FLOWCHARTS, PROCEDURES, AND WIRING DIAGRAMS

Find the symptom below that corresponds to the malfunction, then turn to the corresponding page. Follow the flowchart on that page until the problem is solved.

Troubleshooting Flowchart, Procedure, or Wiring Diagram	Page
Troubleshooting Flowchart: Steamer Not Heating Up, "Power" Light Is Not Lit	22
Troubleshooting Flowchart: Steamer Not Heating Up Properly or Not Cooking Properly, "Power" Light is Lit	23
Troubleshooting Flowchart: Buzzer Does Not Come On When Timer Runs Out	24
Troubleshooting Procedure: Heating Cartridge Check (at Contactor)	25
Troubleshooting Procedure: Power Switch Check	26
Troubleshooting Procedure: Contactor Check	27
Troubleshooting Procedure: Timer and Buzzer Check	28
Troubleshooting Procedure: Door Switch Check	29
Troubleshooting Procedure: High Limit Thermostats Check	30
Troubleshooting Procedure: Water-Level-Control Sensor Check	31
Troubleshooting Procedure: Water Solenoid Check	32
Wiring Diagram for 208/220/240 Volt Models	33
Wiring Diagram for 480 Volt Models	34

## HOW THE STEAMER OPERATES

Compared to steam cookers that have complicated boilers, a StratoSteam steamer is a very simple machine. The heating cartridges are integrated into the bottom plate of the cooking cavity, and begin to heat immediately as soon as the steamer is turned on. As water flows into the cooking cavity it covers the heated bottom plate and is converted to steam. There is no pressure in the steamer. From a cold start the steamer will heat up to cooking temperature in about 4 minutes.

The internal components of the steamer are shown in Figure 10 on the next page.

Turning the control lever to ON mechanically actuates the power switch, and so turns on power to the rest of the circuitry. The "Power" indicator light comes on. Turning the control lever to ON also mechanically closes the cooking-cavity drain valve.

The heating cartridges are controlled by a contactor. The contactor is energized (turning on the heating cartridges) if (1) the door is shut (as sensed by the door switch), (2) the steamer is not overheated (as sensed by the high-limit thermostats), and (3) if there is water in the bottom of the steamer cavity (as sensed by the water-level-control sensor under the cavity).

The flow of water into the cooking cavity is controlled by the water solenoid, which is energized (turning on the water) when the control lever is turned to ON and the door is shut. Hence, when cooking, water flows continuously into the cooking cavity.

If a high-level thermostat detects that the steamer is overheating, or if the water-level-control sensor (which is a thermostat) detects low water (by sensing overheating), the contactor is de-energized (turning off the heating cartridges). Overheating may be caused by too little water entering the cavity, or by lime buildup inside the cavity reducing the conduction of heat to the water.

During operation, excess heated water flows into the drain box where it mixes with a small stream of cold water that is continuously supplied to the drain box (to prevent the draining water from being too hot for the plumbing pipes). Water drains from the drain box out the water drain on the rear of the steamer. If the drain is clogged, water backing-up into the drain box will escape through the drain-box overflow vent on the rear of the steamer.

Any excess steam is vented out the pressure-relief valve located at the top left rear corner of the steamer.

The dial thermometer on the control panel is connected by a capillary tube to a sensor bulb located in the pressure-relief vent. The thermometer does not affect the operation of the steamer.

A mechanical timer activates a buzzer when the timer times out. The timer does not affect anything else!

When the control valve is turned to OFF, power to the electric circuitry is turned off, which de-energizes the contactor and so shuts off the heating cartridges. Turning the control lever to OFF also de-energizes the water solenoid (turning off the water) and mechanically opens the drain valve, permitting all water to drain from the bottom of the cooking cavity.

Figure 10

### How the Steamer Operates

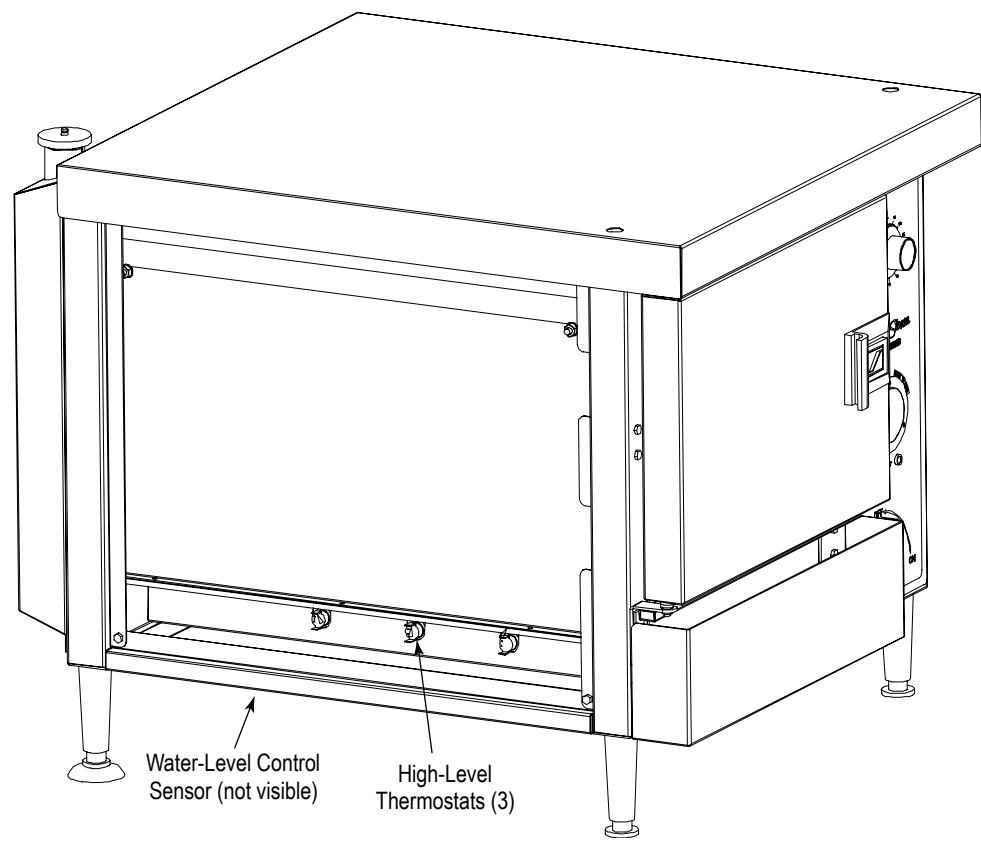
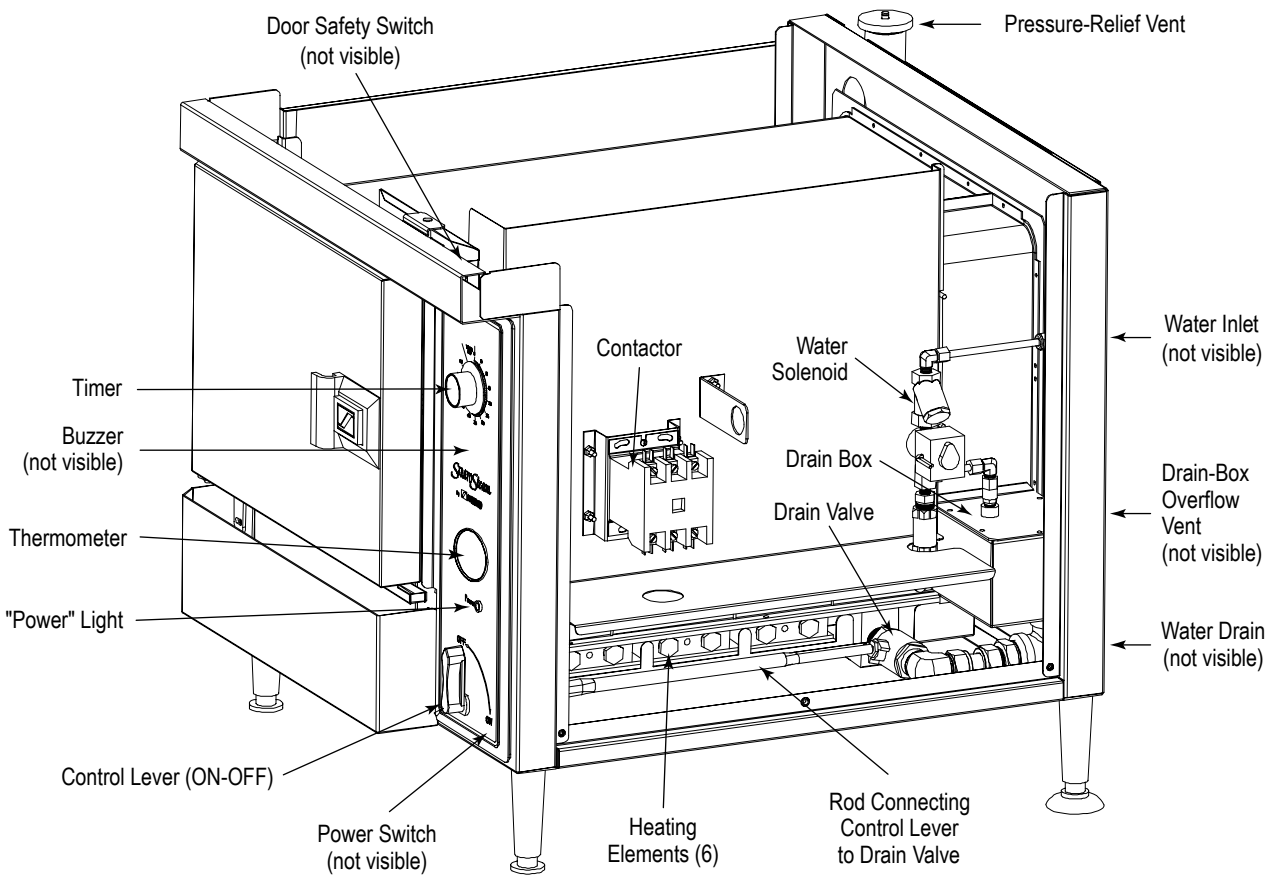

Figure 11

### Steamer Not Heating Up, "Power" Light Is Not Lit

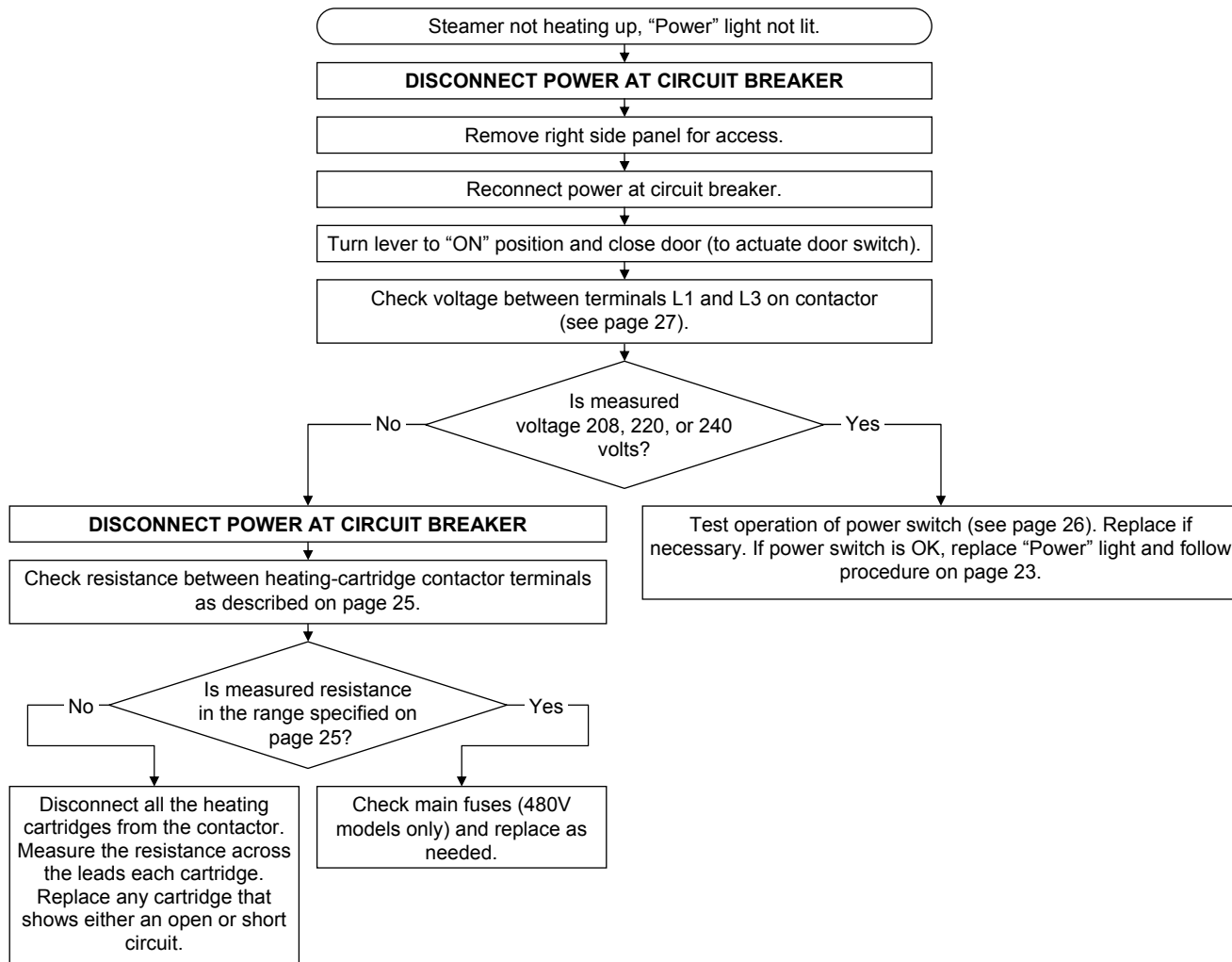

Figure 12

### Steamer Not Heating Up Properly or Not Cooking Properly, "Power" Light is Lit

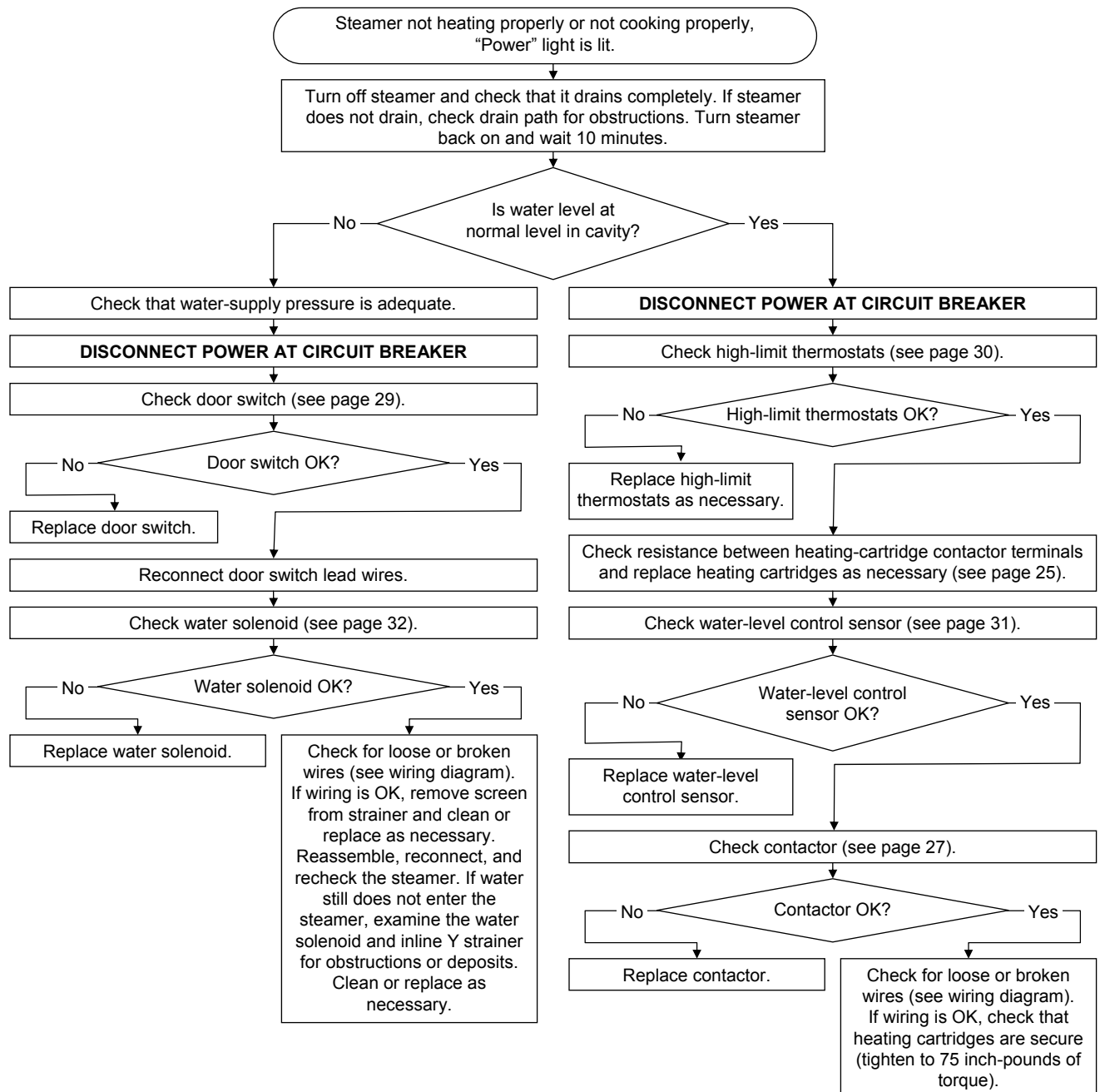

Figure 13

**Buzzer Does Not Come On When Timer Runs Out**

Figure 14

Heating Cartridge Check (at Contactor)

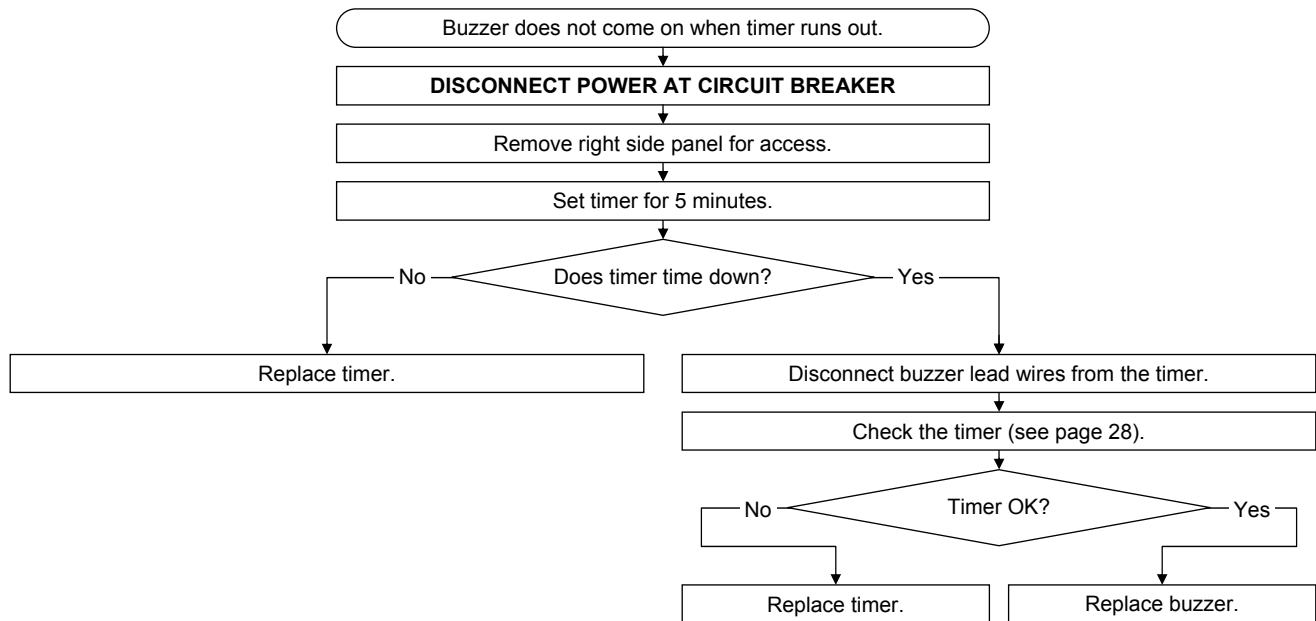
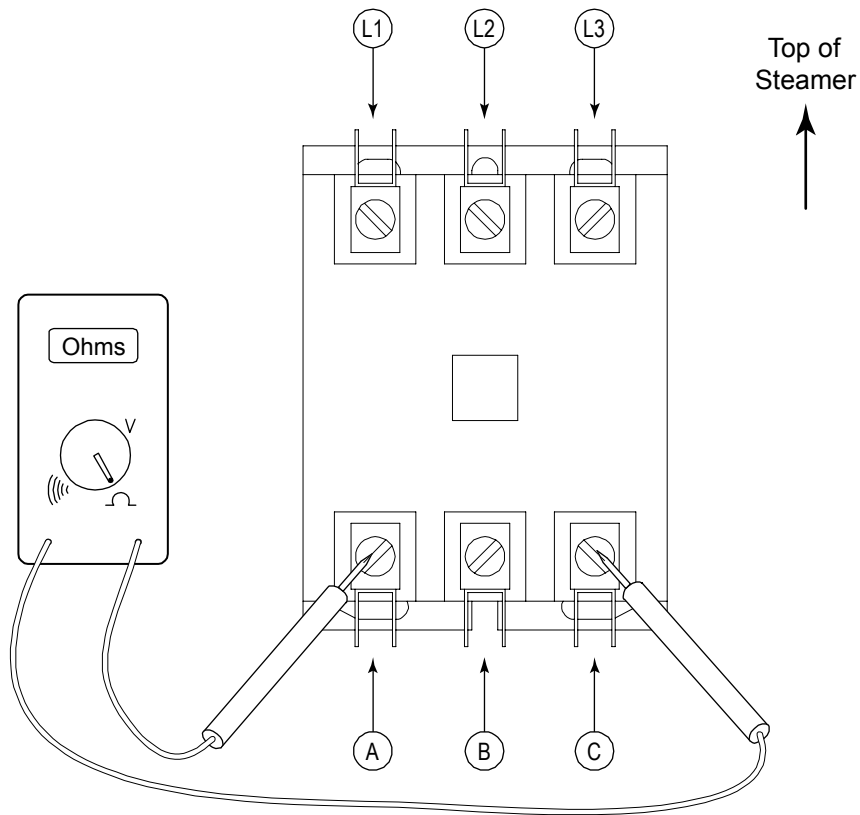

1. **DISCONNECT POWER AT CIRCUIT BREAKER.**
2. Turn Control Lever to OFF.
3. Remove right side panel of steamer.
4. **DO NOT DISCONNECT HEATING-CARTRIDGE LEAD WIRES FOR THIS TEST.**
5. Using a multimeter, check the resistance across contactor terminals as specified in the following table:

Serial-Plate Voltage	Model STRE-3D			Model STRE-5D		
	Allowable Resistance (Ohms)			Allowable Resistance (Ohms)		
	Three-Phase		Single-Phase	Three-Phase		Single-Phase
	A-B and B-C	A-C	A-C	A-B and B-C	A-C	A-C
208	10 to 12	14 to 16	5 to 6	8 to 10	11 to 13	4 to 5
220	12 to 13	15 to 18	6 to 7	9 to 11	13 to 15	5 to 6
240	14 to 16	18 to 21	7 to 9	11 to 13	15 to 17	6 to 7
480	55 to 64	73 to 85	29 to 34	45 to 52	60 to 70	24 to 28

6. If the measured resistance at the contactor is not in the specified range, disconnect all the heating cartridges from the contactor. Measure the resistance across the leads each cartridge. Replace any cartridge that shows either an open or short circuit.

Figure 15

## Power Switch Check

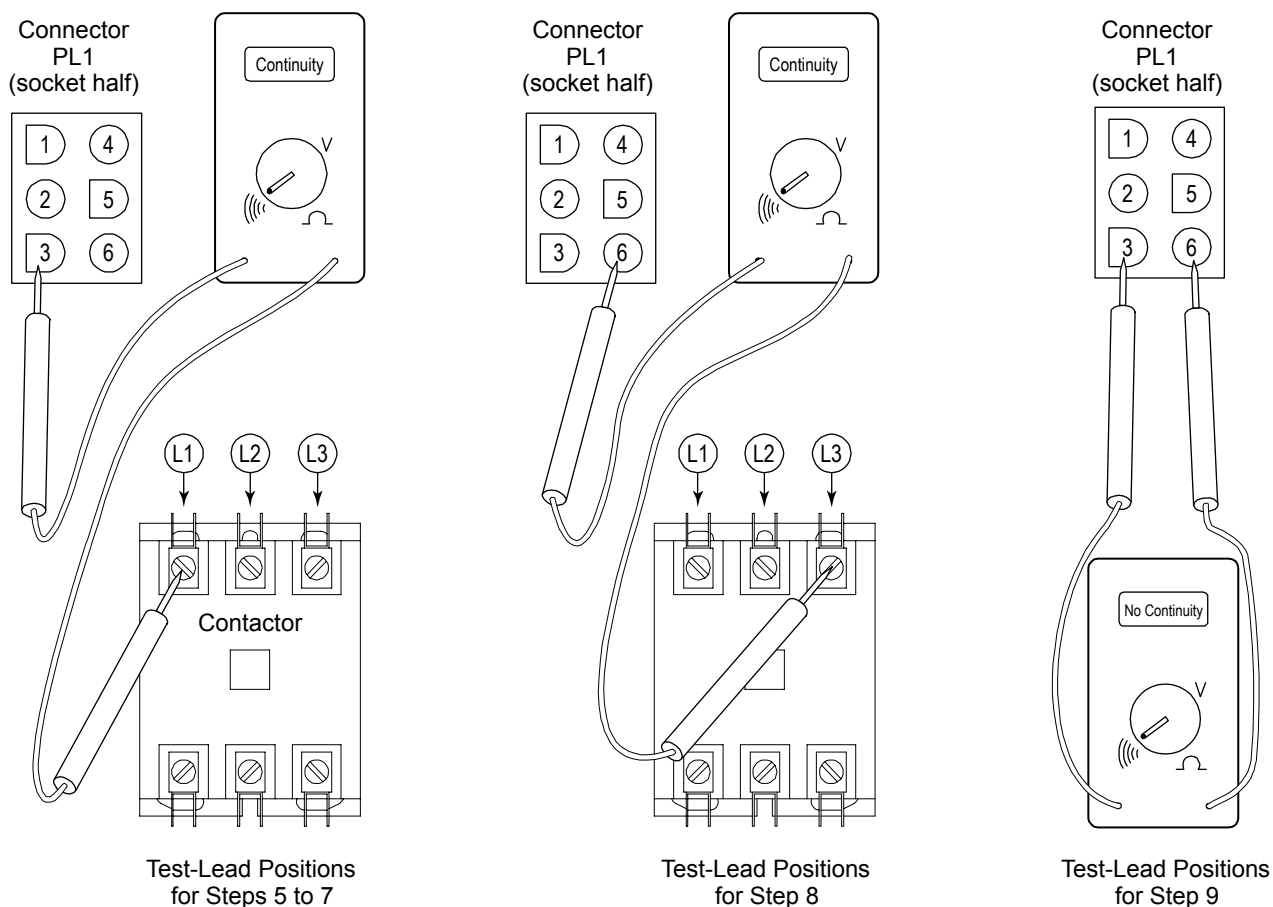

1. **DISCONNECT POWER AT CIRCUIT BREAKER.**
2. Remove right side panel.
3. Turn control lever from OFF to ON and then from ON to OFF while looking to see that the power switch is properly actuating when the lever moves.
4. Disconnect the connector (PL1) that connects the control-panel component wires to the wiring harness.
5. As shown above, place one test lead on terminal L1 of the contactor and the other test lead in position 1 of connector PL1 (the socket half, which is wired to the control panel).
6. Check for continuity with control lever in OFF position (there should not be continuity).
7. Check for continuity with control lever in ON position (there should be continuity).
8. Repeat steps 5 through 7 with one test lead on terminal L3 of the contactor and the other test lead in position 2 of connector PL1 (as shown above).
9. Place one test lead on PL1 position 1 and the other test lead on PL1 position 2 (as shown above). Check for continuity with control lever in the ON position (there should not be continuity).
10. If continuity checks are incorrect, replace power switch.
11. Reconnect lead wires.

Figure 16

## Contactor Check

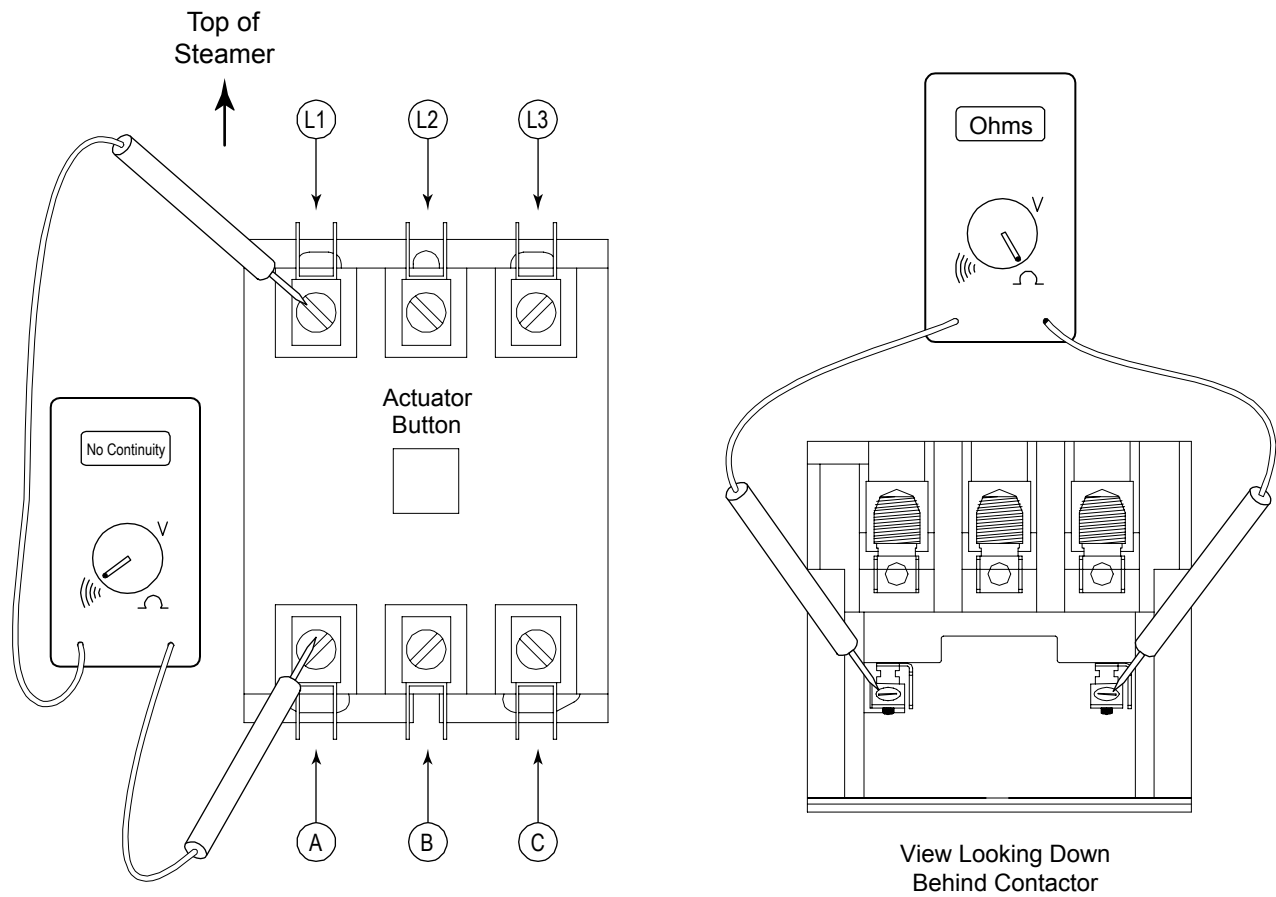

1. **DISCONNECT POWER AT CIRCUIT BREAKER.**
2. Remove right side panel.
3. Depress actuator on top of contactor. Actuator should travel freely and spring back when released.
4. Check for continuity between contacts L1 and A as shown above. There should be no continuity.
5. Repeat Step 4 for contacts L2 and B and for contacts L3 and C.
6. Remove wires B3 and B9 from contactor coil.
7. Place test leads on contactor coil terminals as shown in "View Looking Down" shown above and check resistance
8. If resistance is not in the range 350 to 425 ohms, replace contactor.
9. Reconnect all wires.

Figure 17

## Timer and Buzzer Check

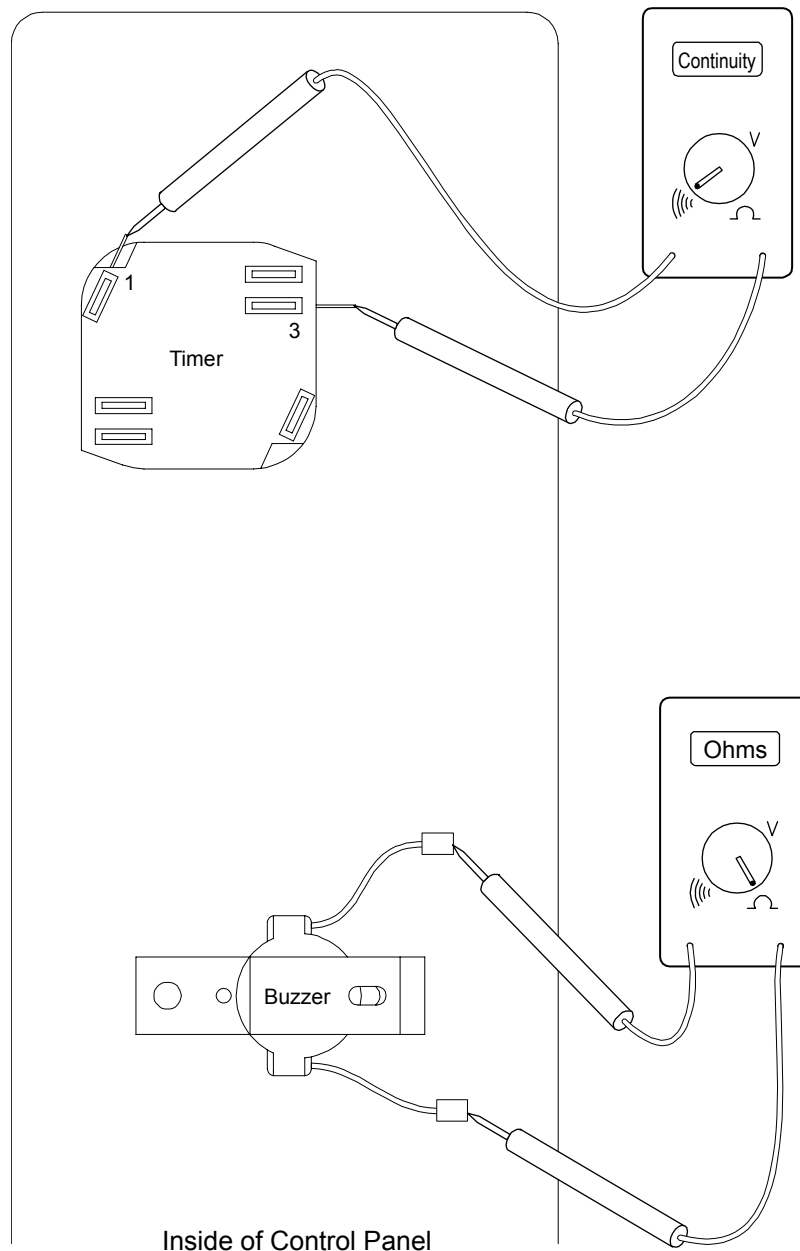

1. **DISCONNECT POWER AT CIRCUIT BREAKER.**
2. Remove right side panel.
3. Set timer for one minute and allow to time out. If timer does not run, then replace timer.
4. Disconnect from the timer the wire that leads to the buzzer.
5. Disconnect connector PL1 to separate the other buzzer lead wire from the wiring harness.
6. Place test leads between positions 1 and 3 on the timer (as shown above).
7. Check for continuity when the timer has run down (so the buzzer should be on). If no continuity, replace timer.
8. Disconnect other lead wire from buzzer. Place test leads in terminals of buzzer lead wires (as shown above).
9. Check that resistance is approximately 3.4 Kohms. If it is not, replace the buzzer.
10. Reconnect wires.

Figure 18

## Door Switch Check

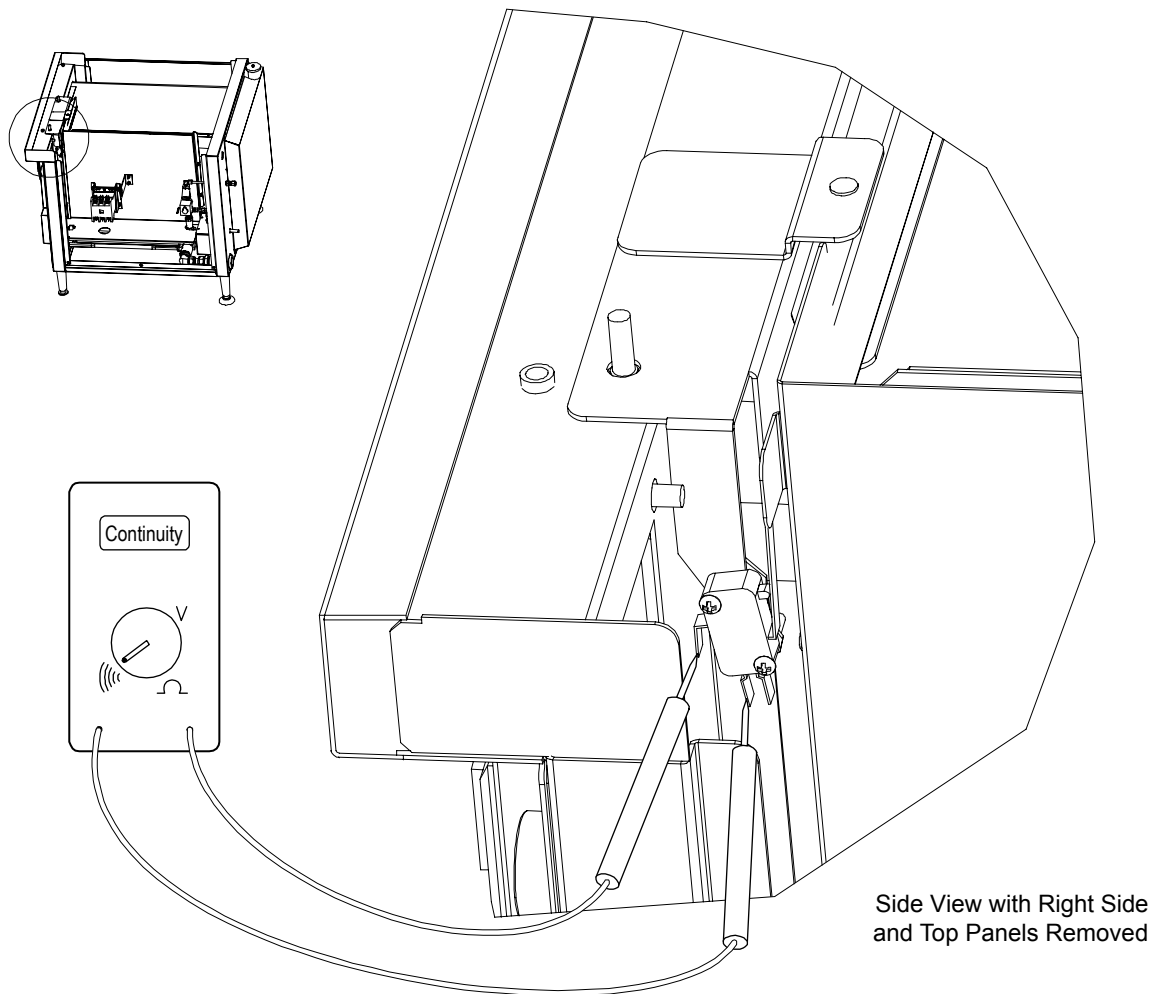

1. **DISCONNECT POWER AT CIRCUIT BREAKER.**
2. Remove right side panel.
3. Open and close the steamer's door while looking to see that the door switch actuator rod actuates the door switch when the rod moves.
4. Disconnect the wiring harness from the switch terminals at the two places shown above (where the test-probe tips are located).
5. Place the test probes on the switch terminals (as shown above).
6. Check for continuity with the door open (there should NOT be continuity).
7. Check for continuity when the door is closed (there should be continuity).
8. If the continuity checks are not correct, replace the door switch.
9. Reconnect connector the wiring harness to the switch terminals.

Figure 19

## High-Limit Thermostats Check

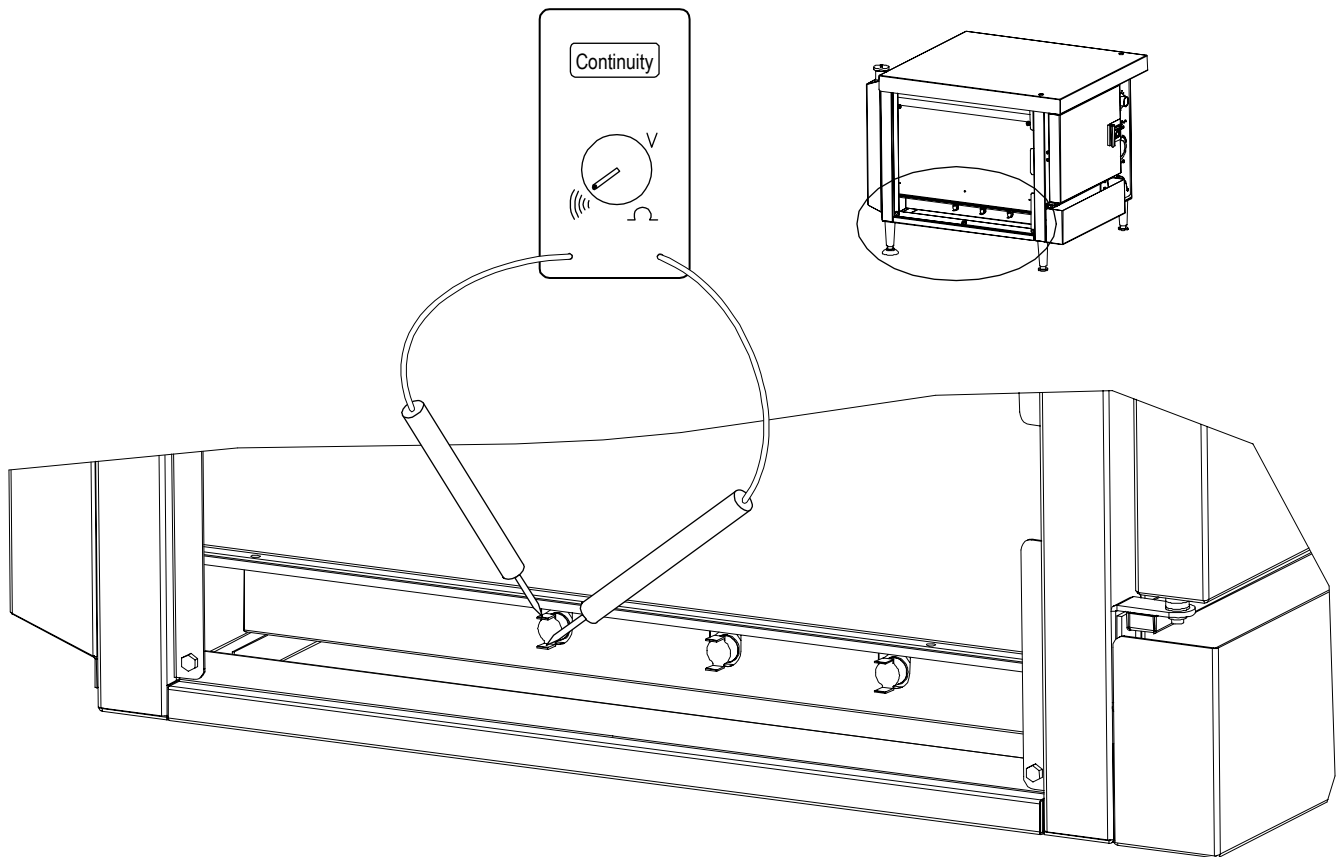

1. Allow cavity bottom to cool before performing this test.
2. **DISCONNECT POWER AT CIRCUIT BREAKER.**
3. Remove left side panel.
4. Disconnect wire B4 from left (as shown above) high-limit thermostat.
5. Disconnect wire B5 from right high-limit thermostat.
6. Disconnect remaining high-limit thermostat wires B11 and B12.
7. Test each high-limit thermostat for continuity (as shown above). There should be continuity when the thermostat is cool. Replace as necessary.
8. Reconnect wires.

Figure 20

### Water-Level-Control Sensor Check

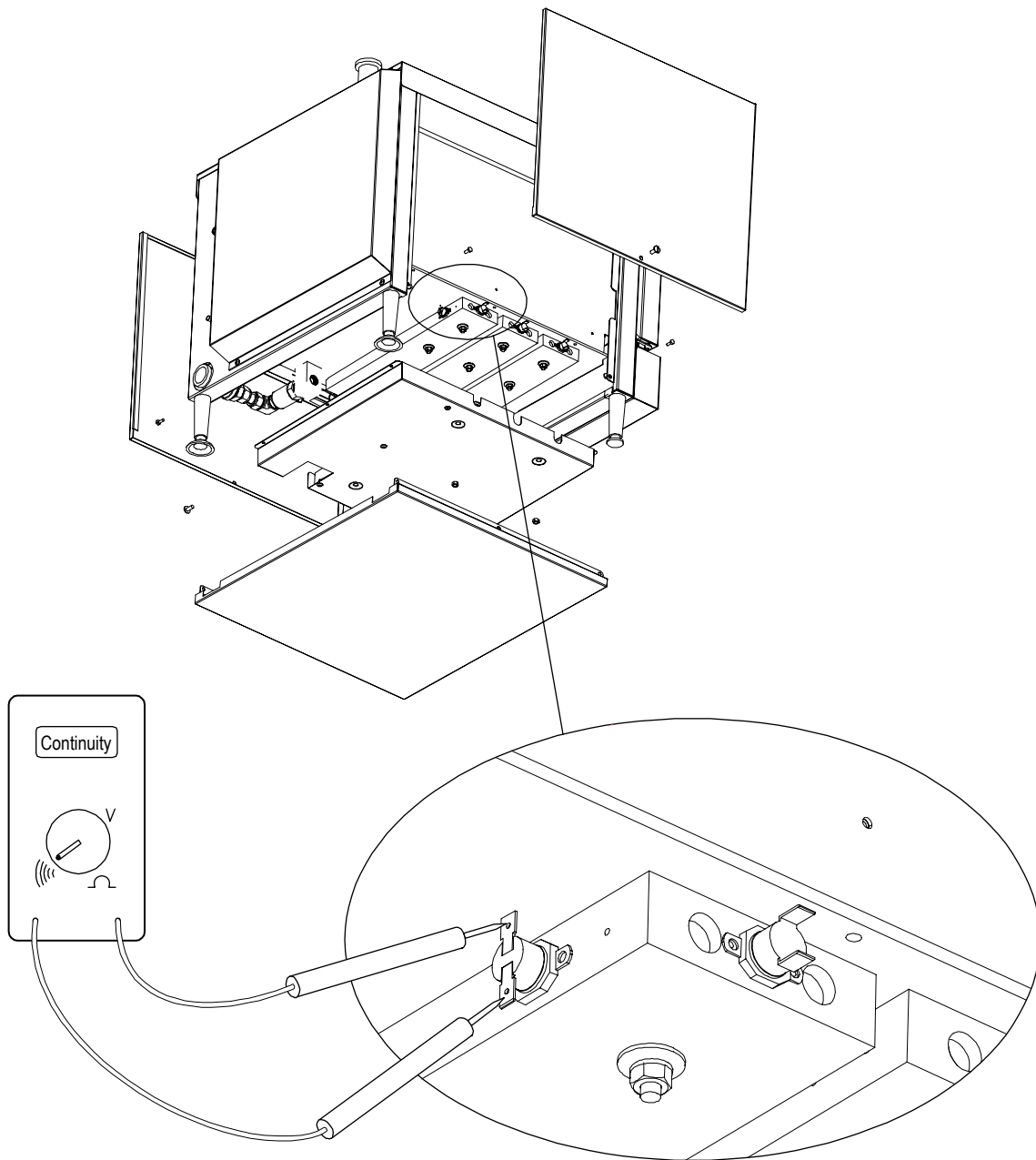

1. **DISCONNECT POWER AT CIRCUIT BREAKER.**
2. Remove the left and right side panels.
3. Remove bottom panel (four screws).
4. Remove insulation cover panel (four nuts).
5. Locate the water-level-control sensor (at the rear edge of the rear element block). Disconnect wires B1 and B2 from the sensor.
6. Place test leads across water-level-control sensor terminals (as shown above) and check for continuity when the sensor is cool. If no continuity, replace sensor.
7. Reconnect wires and reassemble.

Figure 21

## Water Solenoid Check

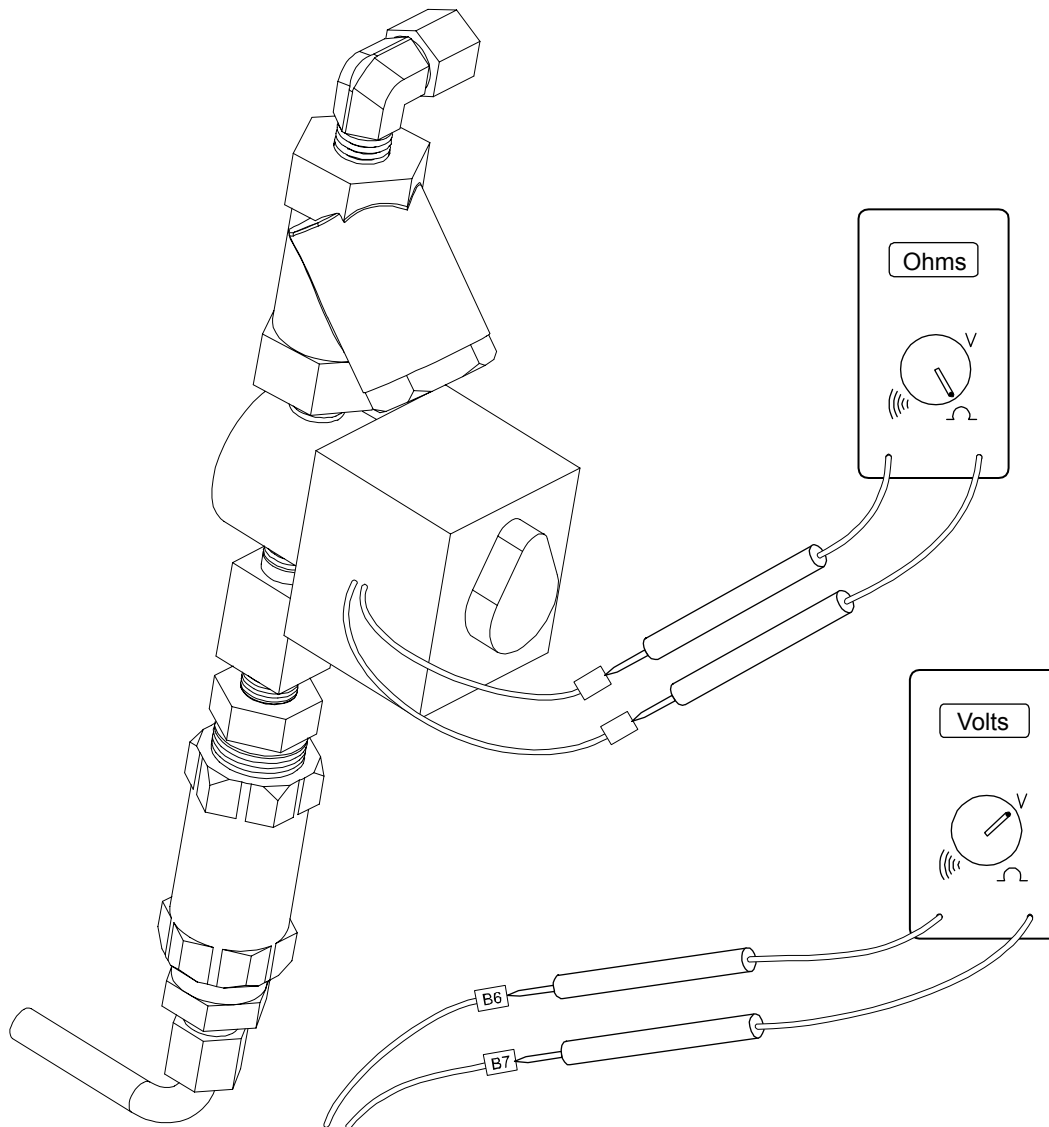

1. **DISCONNECT POWER AT CIRCUIT BREAKER.**
2. Remove right side panel.
3. Disconnect wires B6 and B7 from water solenoid lead wires.
4. Place test probes into water solenoid lead wires as shown above.
5. Resistance should be approximately 800 ohms. Replace if necessary.
6. Apply waterline pressure to water inlet. Water should not leak out of the compression fittings. If necessary, replace water solenoid. Check to see that water is slowly running into the cooking cavity.
7. Reconnect solenoid lead wires and reconnect power to steamer. When power is turned on with the steamer cool, the solenoid should “click.” If no click is heard, test for 200 to 240 volts on wires B6 and B7. If 200 to 240 volts is present and the water solenoid does not click, replace water solenoid.

Figure 22

Wiring Diagram for 208/220/240 Volt Models

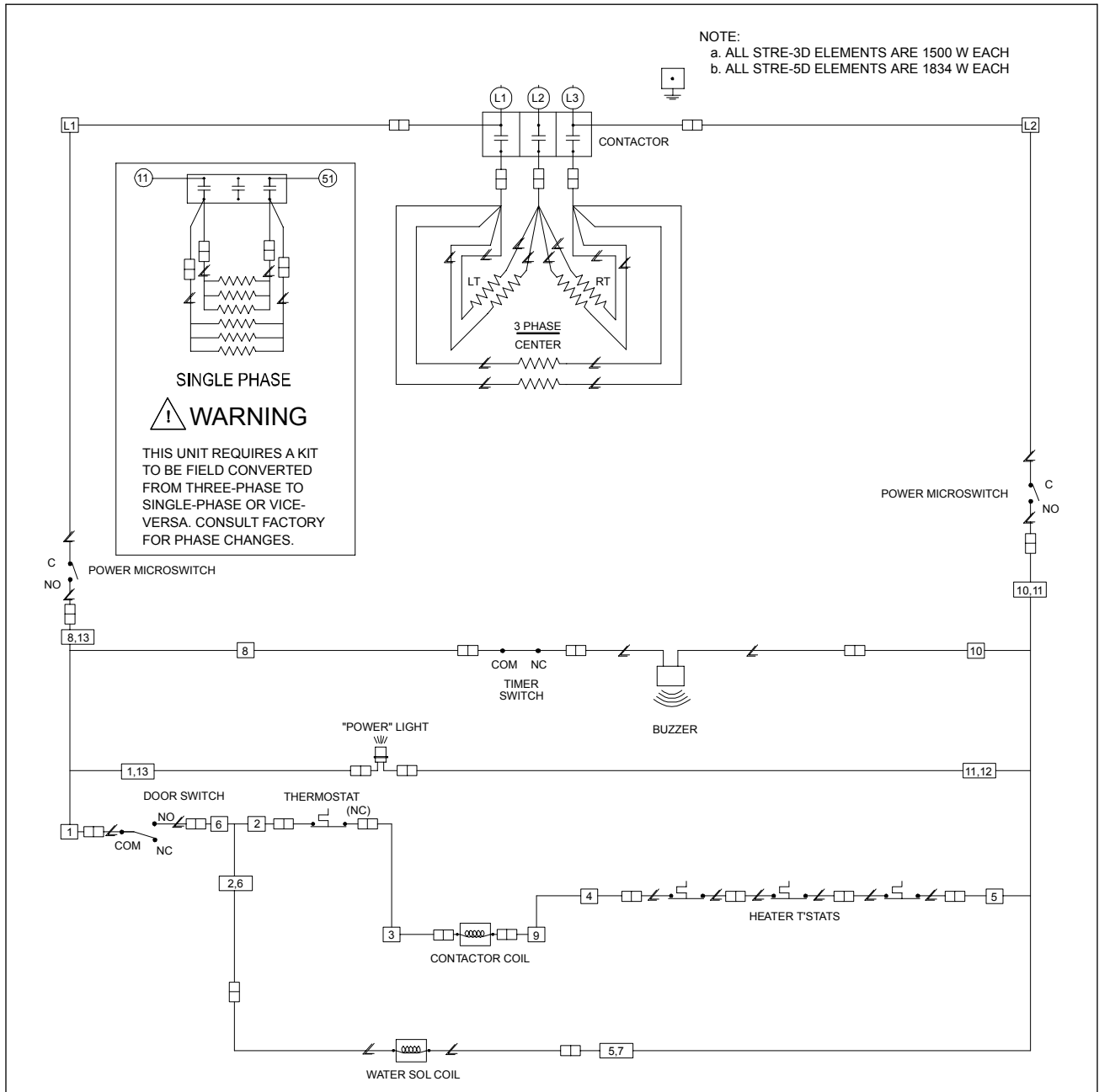

- KEY**
- CONNECTOR OR PLUG
  - ∠ COMPONENT LEAD
  - WIRE NUMBERS

STRE-3D SPECIFICATION						
VOLTAGE	208		220		240	
PHASE	1	3	1	3	1	3
AMPERAGE	44	26	41	24	38	22

STRE-5D SPECIFICATION						
VOLTAGE	208		220		240	
PHASE	1	3	1	3	1	3
AMPERAGE	53	31	51	29	46	27



WIRING DIAGRAM  
 208/220/240V  
 MODEL STRE-3D & STRE-5D

P/N  
 1185153

Figure 23

Wiring Diagram for 480 Volt Models

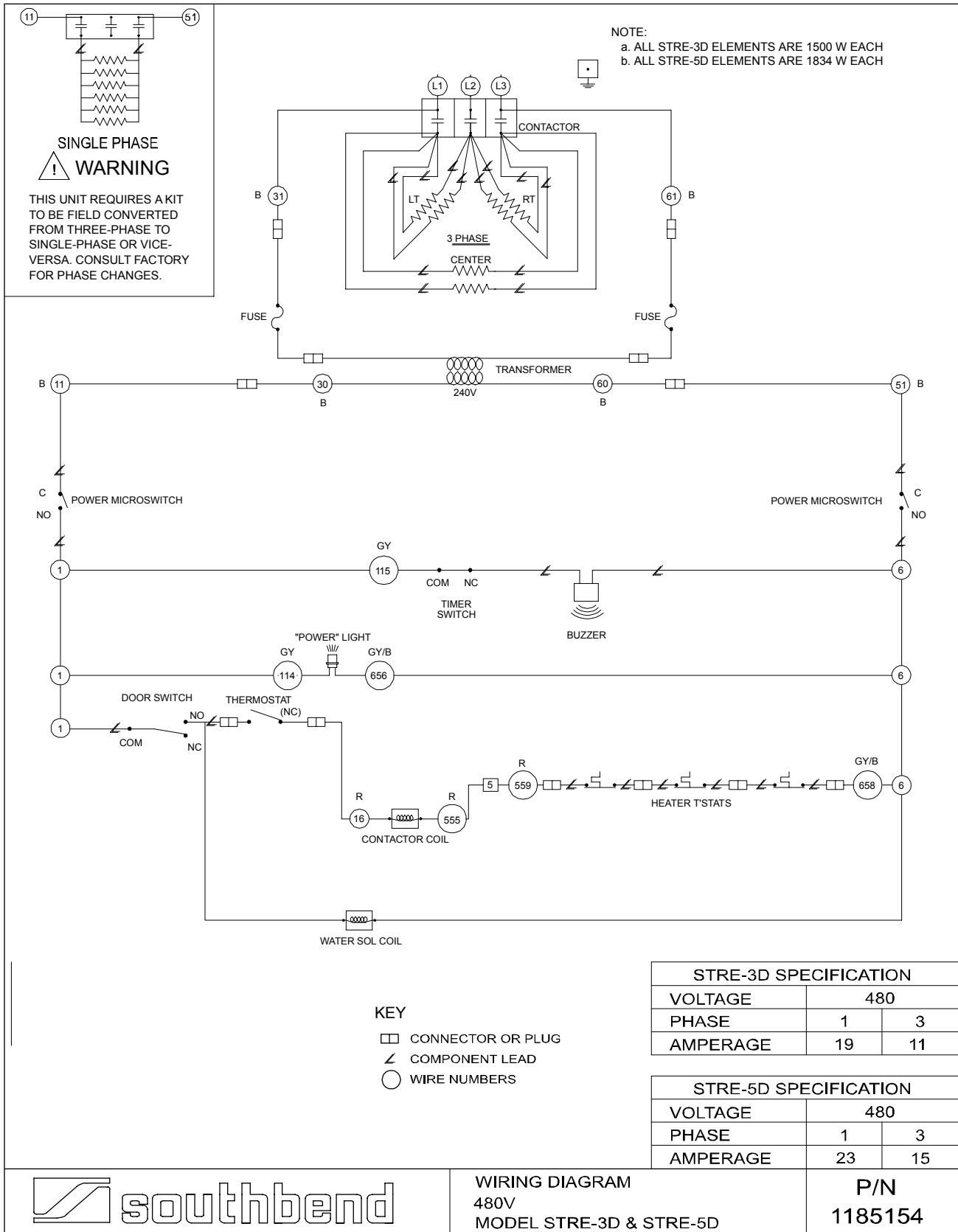

## PARTS

The following parts diagrams list and show serviceable parts. For parts not listed, contact a Southbend Authorized Parts Distributor or a Southbend Authorized Service Agency.

<b>Parts Diagram</b>	<b>Page</b>
Structural Parts	36
Door Assembly Parts	38
Door Switch Parts	39
Control Panel Parts	40
Heating Cartridges, Thermostats, and Contactor Parts	41
Water Train Parts	42
Cabinet Base Parts	44

## Structural Parts

See drawing on following page.

Key	Part Number	Quantity*		Description
		3D	5D	
1	1185026	1	-	STRE-3D DOOR ASSEMBLY (see page 38 for individual parts)
	1185122	-	1	STRE-5D DOOR ASSEMBLY (see page 38 for individual parts)
2	1185016	1	1	DRIP PAN
3	1185115	1	-	DOOR GASKET, STRE-3D
	1185135	-	1	DOOR GASKET, STRE-5D
4	1185072	1	1	DOOR SWITCH ASSEMBLY (see page 39 for individual parts)
5	1185036	1	1	FLOOR PANEL
6	1185103	1	-	SIDEWALL ASSEMBLY STRE-3D
	1185123	-	1	SIDEWALL ASSEMBLY STRE-5D
7	1178668	1	-	PAN GUIDE, LEFT SIDE, STRE-3D
	1178664	-	1	PAN GUIDE, LEFT SIDE, STRE-5D
8	1178663	1	-	PAN GUIDE, RIGHT SIDE, STRE-3D
	1178669	-	1	PAN GUIDE, RIGHT SIDE, STRE-5D
9	1185019	2	-	SIDE PANEL, LEFT OR RIGHT STRE-3D
	1185137	-	2	SIDE PANEL, LEFT OR RIGHT STRE-5D
10	1185020	1	1	TOP PANEL
11	1-2476	2	2	PLUG, BUTTON, ZN PLATED, 5/8"
12	1185042	1	-	REAR INSULATING COVER STRE-3D
	1185138	-	1	REAR INSULATING COVER STRE-5D
13	1185075	1	-	REAR PANEL ASSEMBLY STRE-3D
	1185121	-	1	REAR PANEL ASSEMBLY STRE-5D
14	1185189	1	-	COVER, SIDE INSULATION STRE-3D
	1185192	-	1	COVER, SIDE INSULATION STRE-5D
15	1185078	1	1	BRACKET, CONT S/A
16	1185172	1	1	WIRING SUPPORT BRACKET
17	1185067	1	1	BOTTOM PANEL ASSEMBLY
18	1185185	1	1	PANEL, COVER BOTTOM INSULATION
19	1178485	2	2	FRONT LEG
20	1178486	2	2	REAR LEG

\* Quantity of part used may depend on model (STRE-3D or SRTE-5D).

Figure 24

### Structural Parts

See parts list on previous page.

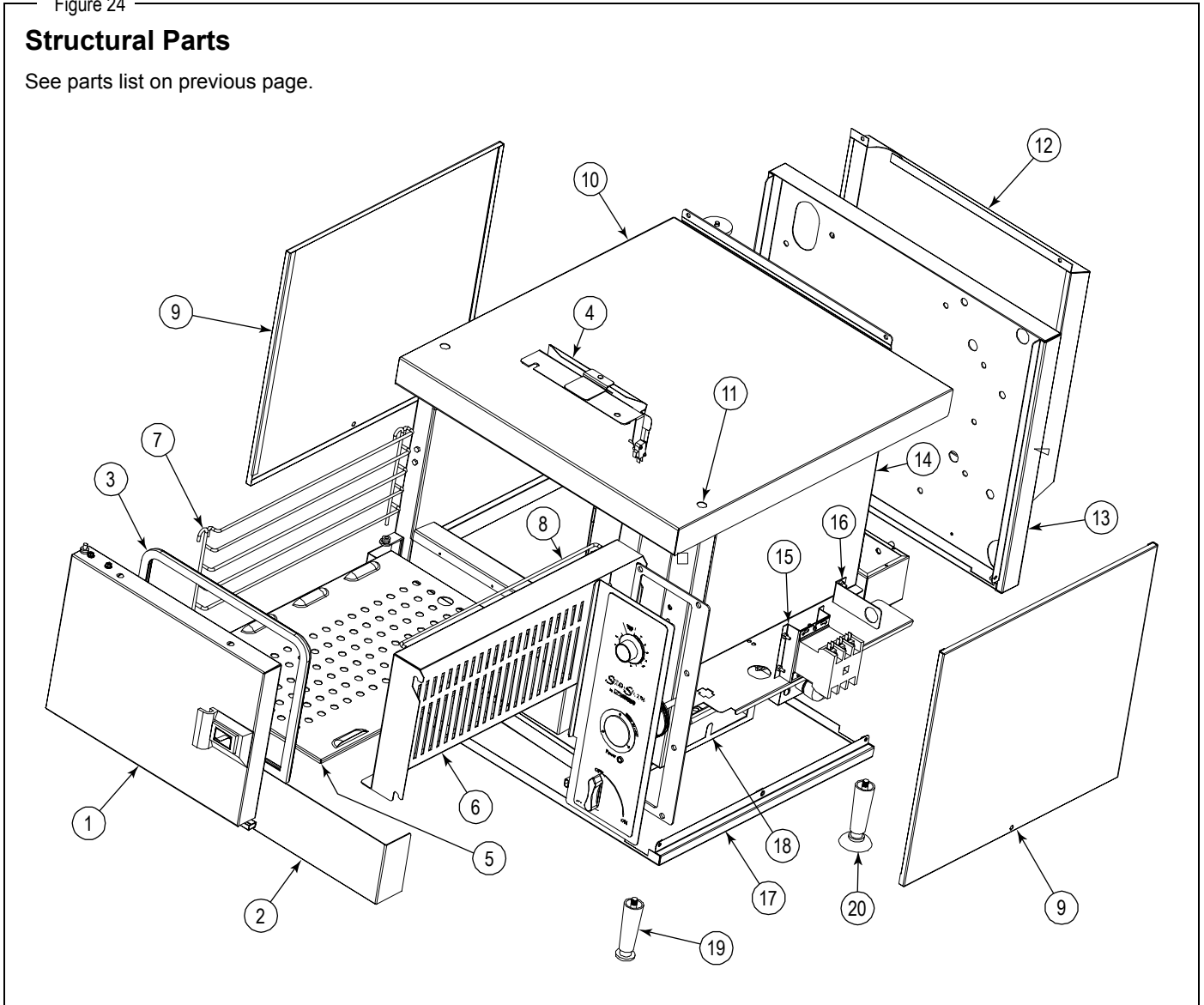
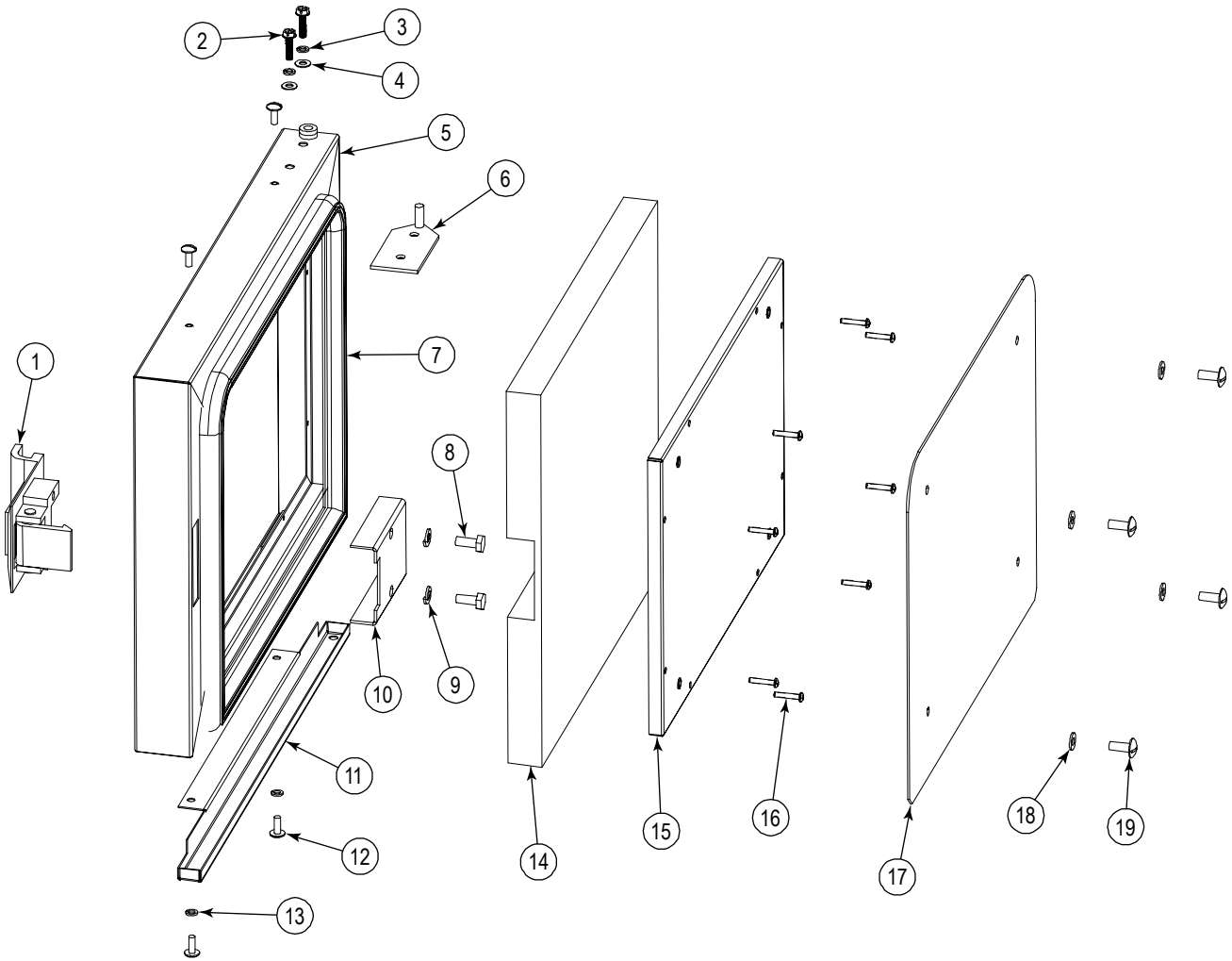

Figure 25

**Door Assembly Parts**



Note: The entire door, assembled, can be ordered (see page 36).

Key	Part Number	Qty	Description
1	1177317	1	LATCH ASSEMBLY
2	1177344	4	SCREW, #10-24X3/4 SLOTTED HEX
3	1146527	6	WASHER #10 LOCK, SS, 300
4	1146526	4	WASHER, #10, FLAT
5	1185053	1	PANEL W/A, R2 STACKABLE
6	1185028	2	HINGE PLATE W/A
7	1185115	1	GASKET, DOOR R2 REDESIGN
8	1146268	2	BOLT, 1/4-20X5/8 HEX HEAD, SS
9	6600412	2	LOCK WASHER, SS
10	1177086	1	RETAINER
11	1185048	1	TRAY, DOOR CONDENSATION
12	1146390	4	SCREW, 10-24X1/2, SS, TRUSS SLOT
13	PH-292	2	NYLON WASHER, 1/4 X 1/2 X 1/8
14	1185029	1	INSULATION, DOOR
15	1185023	1	SUPPORT W/A, DOOR GASKET
16	1173254	8	SCREW, 6-32X3/4, SELF TAP
17	1185118	1	RETAINER, DOOR GASKET
18	1180460	4	WASHER, FLAT #10
19	1173224	4	SCREW, 1/2-20 X 5/8 S, SLOT TRS

Figure 26

**Door Switch Parts**

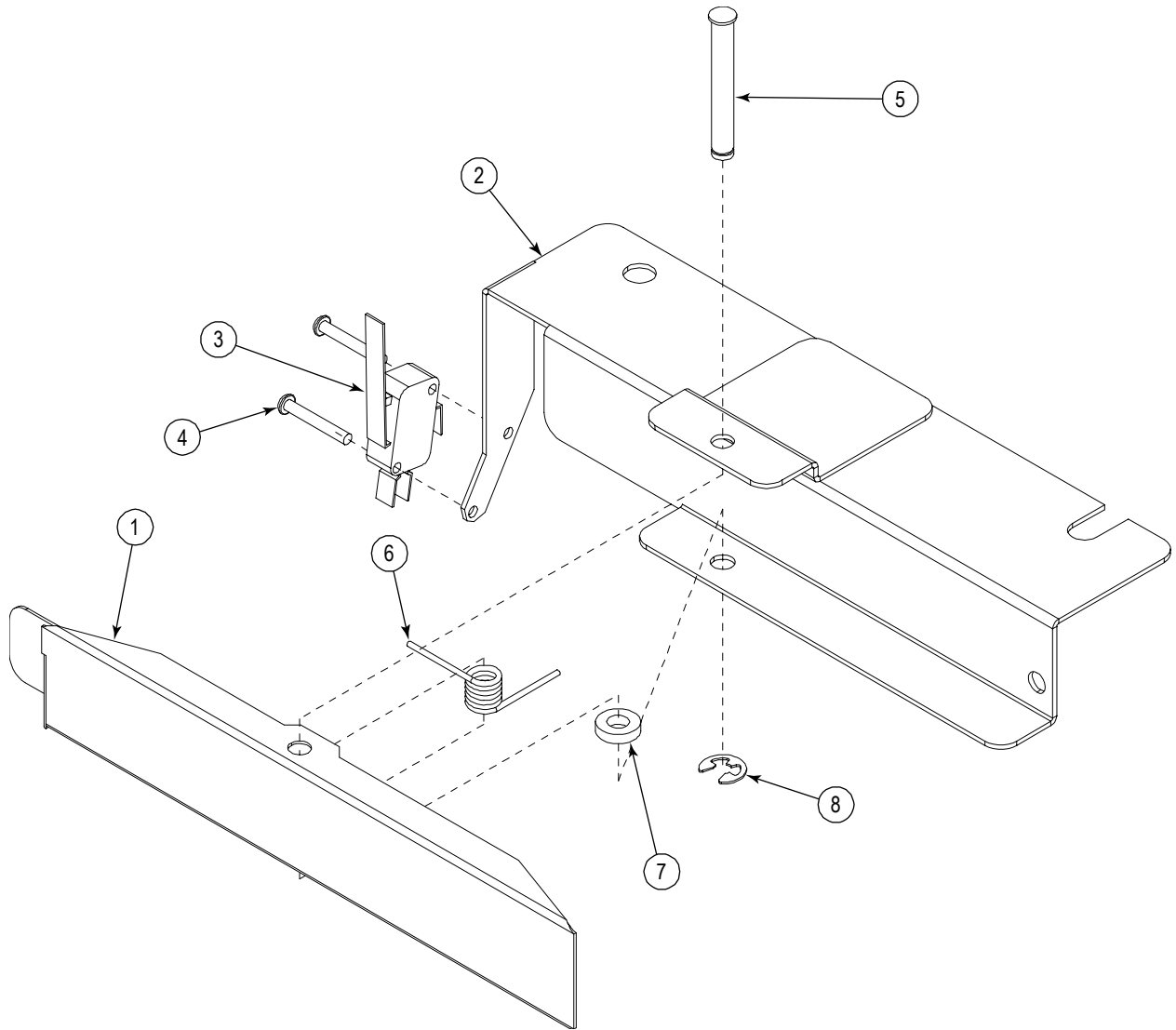

Note: The entire door switch, assembled, can be ordered (see page 36).

Key	Part Number	Qty	Description
1	1185070	1	ARM, DOOR SW SWING STRATOSTEAM
2	<a href="#">1185071</a>	1	BRACKET W/A, STRATOSTEAM, DOOR SWITCH
3	<a href="#">1185195</a>	1	SWITCH, DOOR, SPDT, 15 AMP SUBMINIATURE
4	<a href="#">1146320</a>	2	SCREW, 6-32X1 ROUND HEAD
5	<a href="#">1177081</a>	1	PIN, .250 DIA, SS, CAST LATCH STEAMER
6	<a href="#">1177082</a>	1	SPRING, DOOR HANDLE
7	<a href="#">PH-292</a>	1	NYLON WASHER, 1/4 X 1/2 X 1/8
8	<a href="#">6600402</a>	1	RING, RETAINING S.S. COMBI

Figure 27

**Control Panel Parts**

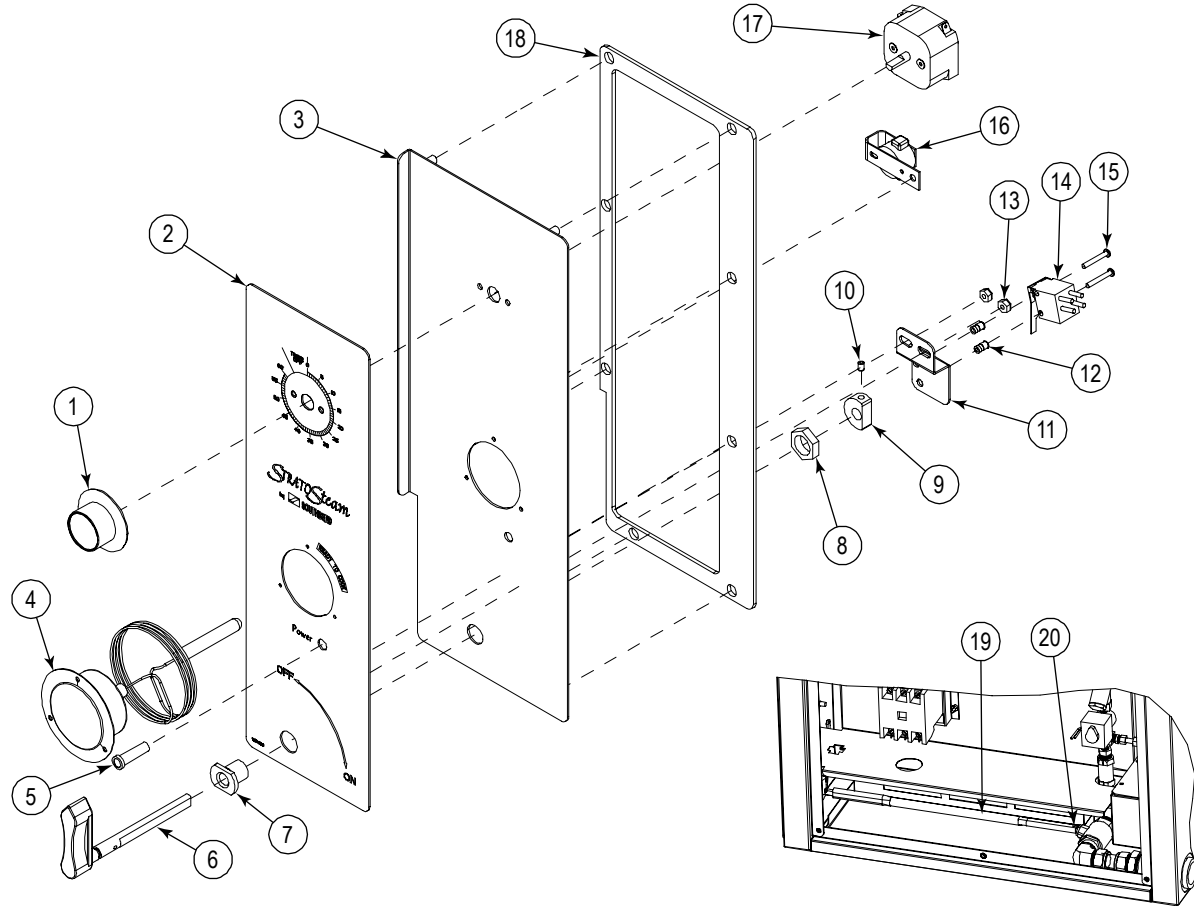

Key	Part Number	Qty	Description
1-17	1185039	1	CONTROL PANEL ASSEMBLY (assembled)
1	1170337	1	KNOB
2	1185058	1	POLYPANEL, CONTROL
3	1185038	1	PANEL, CONTROL W/A
4	1185205	1	GUAGE, THERMOMETER 2 IN
5	1170350	1	LIGHT, AMBER 240V SIGNAL
6	1178388	1	VALVE LEVER W/A
7	1177770	1	BUSHING, VALVE LEVER MOUNT
8	1177865	1	NUT, HEX, 5/8-18, BRASS
9	1178276	1	CAM ACTUATOR
10	1178549	1	SCREW, SET
11	1185056	1	BRACKET, ON/OFF SWITCH
12	1183429	2	INSERT, KNURLED
13	6600430	2	LOCKNUT
14	1178535	1	SWITCH, POWER
15	1146320	2	SCREW, 6-32X1 ROUND HD
16	1175712	1	BUZZER ASSEMBLY
17	1178341	1	TIMER, MECHANICAL
18	1185080	1	GASKET, CONTROL PANEL
19	1185031	1	VALVE ACTUATION ROD
20	1178393	1	1/8 X 1 1/4 18-8 COTTER PIN
*	1185161	1	WIRING HARNESS

\* Not shown on drawing.

Figure 28

### Heating Cartridges, Thermostats, and Contactor Parts

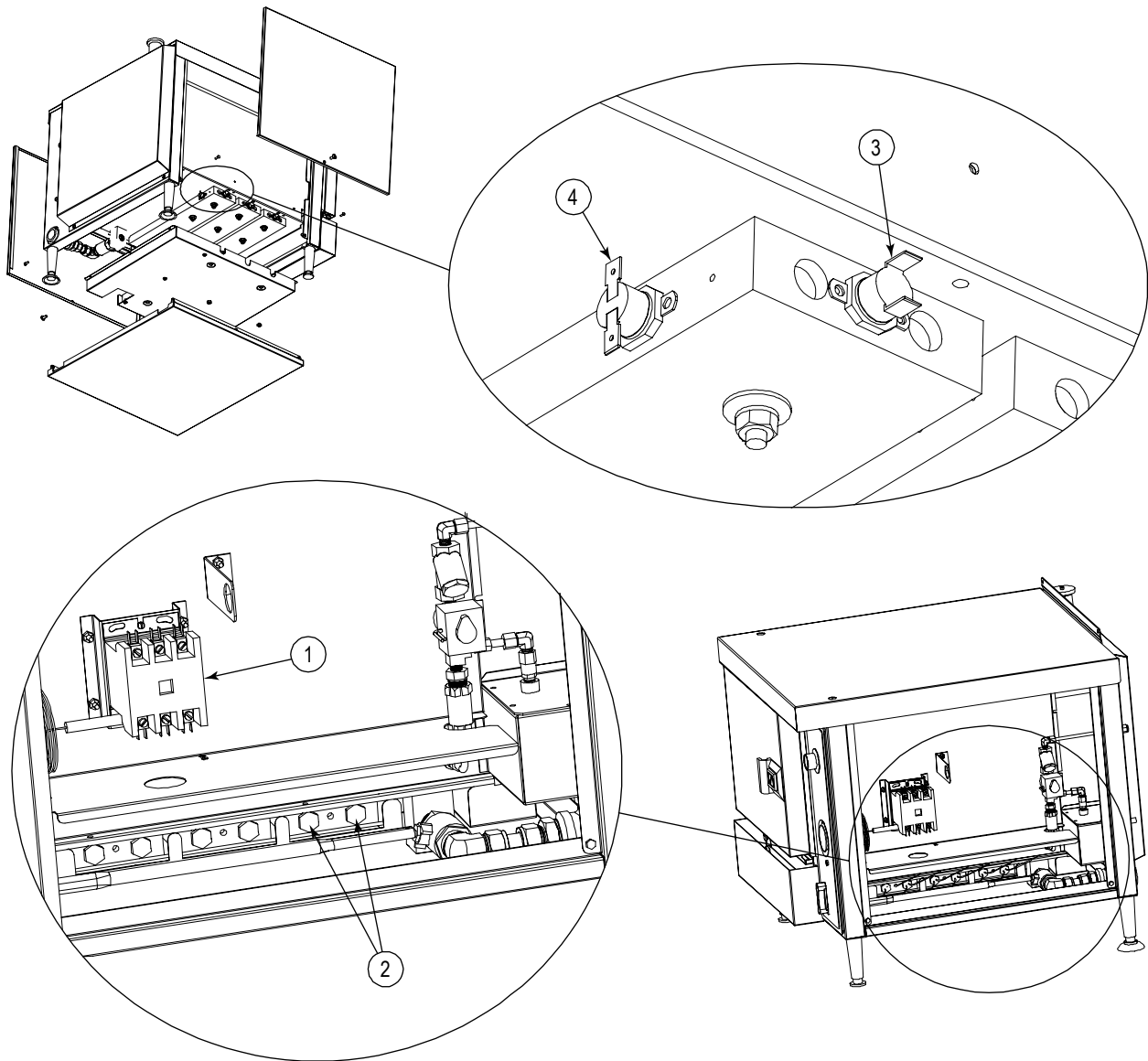

Key	Part Number	Quantity*		Description
		3D	5D	
1	1181032	1	1	CONTACTOR 208-240V
2	1181501	6	-	HEATER CARTRIDGE, 208V 60HZ (for Model STRE-3D)
	1181771	-	6	HEATER CARTRIDGE, 208V 60HZ (for Model STRE-5D)
	1181502	6	-	HEATER CARTRIDGE, 220V 50/60HZ (for Model STRE-3D)
	1181772	-	6	HEATER CARTRIDGE, 220V 50/60HZ (for Model STRE-5D)
	1181503	6	-	HEATER CARTRIDGE, 240V 60HZ (for Model STRE-3D)
	1181773	-	6	HEATER CARTRIDGE, 240V 60HZ (for Model STRE-5D)
	1181504	6	-	HEATER CARTRIDGE, 480V 60HZ (for Model STRE-3D)
	1181774	-	6	HEATER CARTRIDGE, 480V 60HZ (for Model STRE-5D)
3	1185197	3	3	HIGH TEMP LIMIT THERMOSTAT
4	1185177	1	1	CONTROL THERMOSTAT

\* Quantity of part used may depend on model (STRE-3D or SRTE-5D).

## Water Train Parts

See drawing on following page.

Key	Part Number	Qty	Description
1-11	1184263	1	COLD WATER FILL ASSEMBLY (assembled)
1	1185150	1	1/4" COMPRESSION BULKHEAD FITTING
2	1185149	1	TUBE, WATER INLET
3	P4119	1	ELBOW, BRASS
4	1184260	1	STRAINER Y INLINE
5	1176384	1	NIPPLE 1/8 NPT 3/4 LNG
6	1174933	1	SOLENOID VALVE
7	1184261	1	TEE 1/8 STREET
8	1184262	1	REDUCER 3/8 TO 1/8 NPT
9	PP-636	1	FLOW REGULATOR
10	PP-286	1	FITTING 3/8 NPT X 1/4 COMP
11	1185151	1	TUBE 1/4" WATER INLET
*	P5552	1	FITTING 1/4" COMP X 1/8" NPT
12	1185152	1	TUBE 1/4 COOLANT
13	P-4119	1	ELBOW
14	1174620	1	SPRAY NOZZLE
15	1185140	1	DRAIN BOX, COVER PANEL
16	1185106	1	DRAIN VALVE
17	1185107	1	3/4" NPT X 3/4 TUBE COMPRESSION ELBOW
18	1185109	1	3/4 TUBE TO 1" NPT M THRU ADAPTER
19	PP-439	1	1" NPT F TEE
20	1185108	1	3/4 OD SS DRAIN TUBE

\* Not shown on drawing.

Figure 29

### Water-Train Parts

See parts list on previous page.

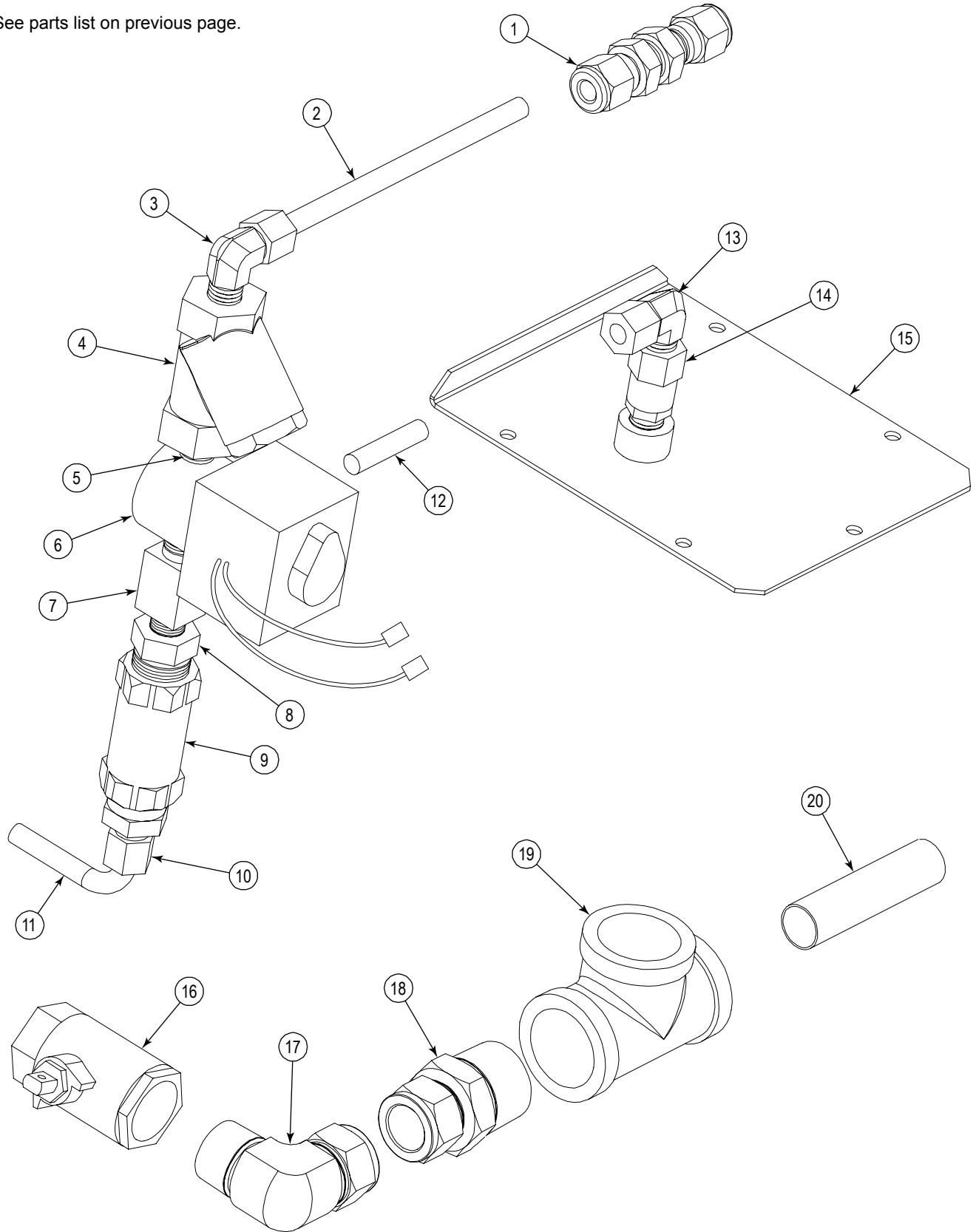

## Cabinet Base Parts

See drawing on following page.

Key	Part Number	Qty	Description
1	<a href="#">1183993</a>	2	PANEL, 24" SS DOOR
2	<a href="#">1183989</a>	2	LINING, 24" SS DOOR
3	<a href="#">1183987</a>	2	HANDLE, CATCH DOOR
*	<a href="#">1182637</a>	2	CATCH, MAGNETIC, SGS
4	<a href="#">1183985</a>	1	HINGE ASSEMBLY, UPPER LEFT
5	<a href="#">1183983</a>	1	HINGE ASSEMBLY, UPPER RIGHT
6	<a href="#">1183984</a>	1	HINGE ASSEMBLY, LOWER RIGHT
*	<a href="#">1183986</a>	1	HINGE ASSEMBLY, LOWER LEFT
7	<a href="#">1184527</a>	1	COVER, 24" BASE BOTTOM
8	1185141	1	BODY SIDE, CAB SS OPEN LT
9	1185144	1	PANEL, TOP CABINET
10	1185143	1	BODY BACK, 24 CABINET
11	1185142	1	BODY SIDE, RT
12	<a href="#">1172650</a>	4	LEG PAD (3/4 X 10 HOLE)
13	<a href="#">1146500</a>	16	1/4 LOCK WASHER
14	<a href="#">1146201</a>	16	1/4 X 30 X 3/4 HEX HEAD
15	<a href="#">1174260</a>	1	LEG PACKAGE (set of four legs, not including bolts, leg pads, or lock washers)
*	<a href="#">1174262</a>	1	EARTHQUAKE LEGS SS (set of four)
* Not shown on drawing.			

Figure 30

### Cabinet-Base Parts

See parts list on previous page.

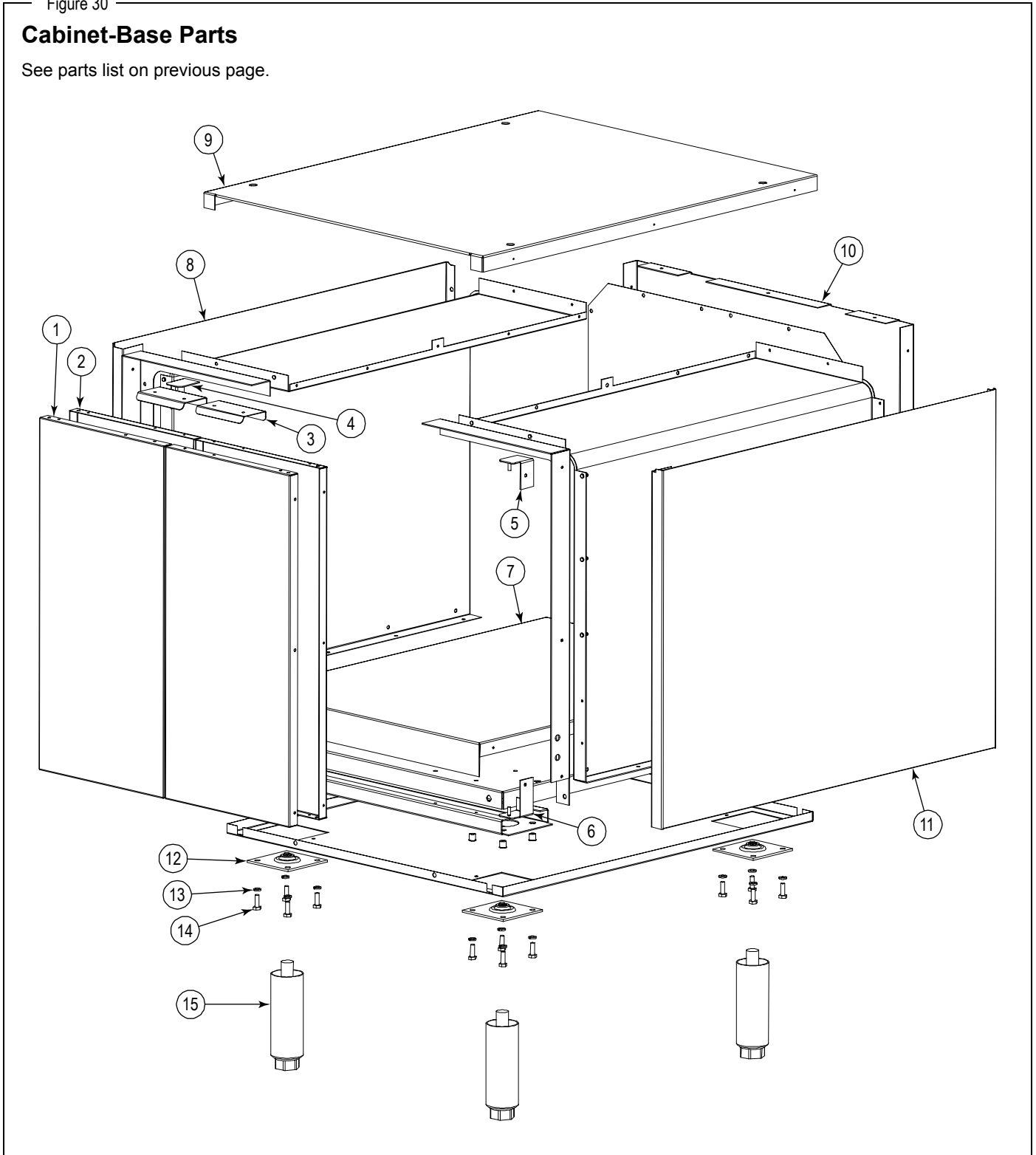

Notes:

Notes:

# STRATOSteam

## StratoSteam Countertop Steamer Models STRE-3D and STRE-5D



A product with the Southbend name incorporates the best in durability and low maintenance. We all recognize, however, that replacement parts and occasional professional service may be necessary to extend the useful life of this appliance. When service is needed, contact a Southbend Authorized Service Agency, or your dealer. To avoid confusion, always refer to the model number, serial number, and type of your appliance.



Southbend  
1100 Old Honeycutt Road, Fuquay-Varina, NC 27526  
[www.southbendnc.com](http://www.southbendnc.com)