

Cream Dispenser Silver King Model SK-1



Manufactured exclusively for
McDonald's®
By
Silver King
1600 Xenium Lane North
Minneapolis, MN 55441
customerservicemd@princecastle.com



<http://tiny.cc/sk-1>



TABLE OF CONTENTS

Product Identification.....	Page 1
Table of Contents.....	Page 1
Warranty Statement.....	Page 2
Electrical Specifications.....	Page 3
Safety Information.....	Page 3
General.....	Page 3
Important.....	Page 3
Unpacking and Setup.....	Page 4
Installation.....	Page 5
Initial Cleaning and Sanitizing.....	Page 6
Initial Start-Up.....	Page 6
Operation— General.....	Page 7
Operation — Dispensing Cream.....	Page 7
Operational Flowchart.....	Page 8
Manager Mode Flowchart.....	Page 9
Cleaning and Refilling the Dispenser.....	Page 10
Troubleshooting Guide.....	Page 11
Parts and Exploded View.....	Page 13
Wiring Diagram.....	Page 14

Warranty Statement

Silver King warrants to the original purchaser of Silver King refrigerated equipment that the equipment shall be free from defects in material and workmanship under normal use and service as outlined in the Technical Manual. This limited warranty shall apply for a period of two (2) years from the date of original purchase. The Compressor will carry an additional three (3) year warranty. All warranties are subject to specific limitations outlined below.

This limited warranty does not apply to repair or replacement required as a result of carelessness, neglect and/or abuse, including improper installation, incorrect voltage supply, tampering with or altering components and/or equipment or failure to perform proper maintenance. Equipment damaged in transit, by fire, flood or an act of God is not covered. This limited warranty does not include freight, handling, installation, labor (following the two (2) year labor warranty period) or other incidental or consequential costs including product and/or economic loss. This limited warranty is in lieu of all other warranties, express or implied, including those of merchantability, and is non-transferable.

Specific provisions of this limited warranty are as follows:

Two (2) Year Parts Warranty

Silver King warrants to the original purchaser of new Silver King equipment that such equipment and all parts thereof will be free of defects in material and workmanship, under normal use and service, for a period of two (2) years from the date of original purchase or 25 months from the date of shipment from the factory, whichever comes first, subject to all terms and conditions herein.

This warranty is limited to repairing or replacing any parts that, at Silver King's discretion, are deemed to be defective within the time period covered by this warranty. The warranty does not cover freight or handling charges incurred to replace such parts. Use of non-OEM parts may, at Silver King's discretion, void this warranty. If approved, warranty credit for non-OEM parts will be issued at the OEM cost.

Replacement parts sold separately are warranted for 90-days from date of purchase.

Five (5) Year Compressor Warranty

Silver King warrants to the original purchaser for a period of five (5) years from the date of original purchase or five (5) years and one (1) month from the date of shipment from the factory, whichever comes first, that it will replace the compressor with one of similar design and capacity, exclusive of delivery and installation charges, if it is found to Silver King's satisfaction to be inefficient or inoperative due to defects in material or factory workmanship. It is the owner's responsibility to return the serial plate of the defective compressor or at Silver King's option the complete compressor, to the factory. Failure to do so will void the warranty.

Two (2) Year Labor Warranty

Silver King warrants to the original purchaser for a period of two (2) years from the date of purchase or 25 months from the date of shipment from the factory, whichever comes first, a limited service labor warranty on Silver King refrigerated equipment subject to the following terms;

A factory issued Service Authorization Number must be obtained prior to work being performed under the labor warranty. Call your supplier or Silver King. Claims submitted without a Service Authorization Number will be paid at Silver King's discretion.

The labor warranty includes standard straight time labor charges in accordance with Silver King's Labor Warranty Guidelines and reasonable travel time, as determined by Silver King.

The warranty does not cover original installation, startup, normal adjustments or maintenance. Normal adjustments and maintenance include, but are not limited to; temperature control adjustments, temperature indicator calibrations, coil and filter cleaning, condensate drain cleaning.

A second service call for a related failure is not covered.

Use of refrigerants other than specified on the equipment serial plate voids the warranty.

All claims must include; model and serial number of equipment, date of purchase, date of failure, and a copy of the service invoice detailing the defect and service performed. No claim will be processed without this information. All claims must be filed within 60 days from date of service.

Safety Information

General Precautions



WARNING

Risk of Electric Shock.

- Always unplug the power cord before servicing the unit or removing the back panel or front apron to avoid electric shock.
- Unit **MUST** be plugged into a 3-prong plug for grounding. Cutting off the grounding spike on the power cord could result in electric shock to the operator during operation.
- Unit must be plugged into a 15 or 20 ampere fuse- or breaker-protected circuit. Use of a larger fuse or breaker could result in damage to the unit and electric shock to the operator.

Moving or Handling Hot Parts.

- Some parts may remain hot even after being unplugged. Always use caution when servicing.

Possible Back Injury.

- Assistance in moving this piece of equipment is strongly recommended to avoid injury.
- Always lift with your legs and not your back when lifting this unit.



WARNING

Indicates information important to the proper operation of the unit. Failure to observe may result in damage to the equipment and/or severe bodily injury or death



CAUTION

Indicates information important to the operation of the unit. Failure to observe may result in damage to the equipment

Electrical Specification

115V 60 Hz 1 Phase

Important

Prince Castle reserves the right to change specifications and product design without notice. Such revisions do not entitle the buyer to corresponding changes, improvements, additions or replacements for previously purchased equipment.

General

The SK-1 Cream Dispenser is designed to hold and dispense bulk coffee cream. It will dispense three portion sizes – 1 cream packet, 2 cream packets or 3 cream packets.

Product Identification

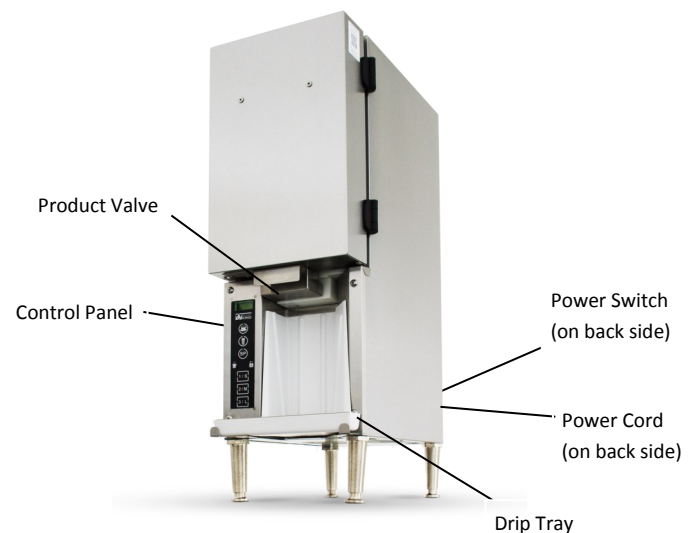

Unpacking and Setup

1

Inspect for shipping damage. Examine the shipping container immediately upon receipt. Any damage to the container or equipment due to shipping should be reported to the transportation company immediately. Claims should be filed within 24 hours. Shipping damage is not the responsibility of Prince Castle nor its Silver King division.

2

Unpack the unit. Take care with box cutters or other sharp instruments not to nick the equipment when opening the shipping container.

Carefully remove the unit from the shipping box. Be sure to follow any orientation or caution labels on the box.

3

Plan the unit's location. When locating this unit, convenience and accessibility are important considerations, but the following factors must be observed:

- Proximity to a 3-prong 110 VAC receptacle for grounding (see Step 4).
- When placing the unit on a counter, the counter must be able to support a minimum of 100 lbs. (45 kg).
- When placed on a counter, the unit must be on the legs supplied. If the legs are removed, the unit will not operate properly and the warranty will be void.
- There must be at least 4" (10.2 cm) of space above, on the sides and behind the unit and open in front.
- Correct serving height is important so that it can be operated properly.
- The unit must be level. The legs are adjustable to aid in leveling the unit.
- Avoid placing the unit next to an oven, heating element or hot air source which would affect the performance of the unit.

4

Meet electrical requirements. Prior to connecting the unit to power, be sure to check the data plate located on the end panel of the cabinet for required voltage. The specifications on the data plate supersede any information contained in this manual. The standard unit is equipped with a seven (7) foot power cord that requires a 115 Volt, 60 Cycle, 1 Phase, properly grounded electrical receptacle, protected with a 15 or 20 ampere fuse or breaker.



WARNING

The power cord comes with a 3-prong plug for grounding purposes. Any attempt to cut off this grounding spike or to connect to an ungrounded adapter plug could result in serious injury, will void the warranty and terminates the manufacturer's responsibility.

Installation



WARNING

To avoid injury, it is recommended that the unit be moved by two people

1

Locate the Unit. Move the unit to its mounting location.

2

Install the four legs underneath the unit. The dispenser is shipped without legs attached. To install them, carefully tilt the unit and thread the legs into the four corner holes on the bottom of the dispenser.

3

Level the Unit. In order for the unit to function properly, level the unit front to back and side to side. Adjust the legs to level the unit.

4

Install the drip tray and drip tray cover



5

Connect the unit to power. Plug in the power cord on the back of the unit, at the left rear. Run the cord along the rear of the shelf and plug it into the designated outlet.



WARNING

The power cord comes with a 3-prong plug for grounding purposes. Any attempt to cut off this grounding spike or to connect to an ungrounded adapter plug could result in serious injury, will void the warranty and terminates the manufacturer's responsibility.

IMPORTANT

After installation and assembly and before the unit goes into service, it must be cleaned and sanitized

Initial Cleaning and Sanitizing

1

Make sure that the switch on the back of the unit is in the "off position". The indicator panel should be unlit

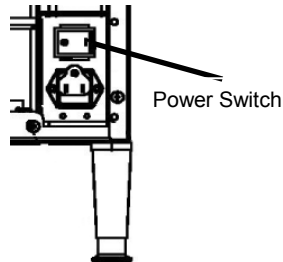

2

Wash the surfaces of the unit with warm, soapy water.

3

Rinse the surfaces with warm water.

4

Turn the valve insert. Pull and turn valve to expose cold block.

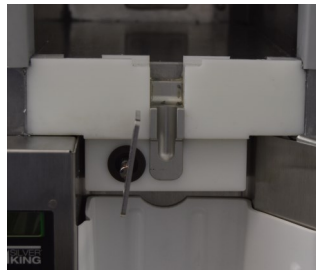

5

Clean the valve and valve area. Use a brush and warm, soapy water to clean the valve. Clean the valve area of the dispenser with a brush and warm, soapy water. Rinse with warm water.

6

Sanitize the valve and valve area. With an approved sanitizing solution, thoroughly clean the valve and valve area. Allow to air dry.

Initial Start-Up

1

Place the switch on the back of the unit in the "on" position. The indicator panel should display the current unit temperature.

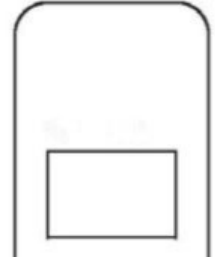

2

Allow the unit to run a minimum of two hours before loading it with product.
Note: It is completely normal for the exterior of the unit to feel warm while it is running.

3

Load cream into the cream dispenser. Once the unit has achieved proper operating temperature, observe the procedures noted in the label on the door liner for loading cream in the cream dispenser

Operation—General

1

Indicator Panel — The indicator panel contains a digital LED display that reads the product temperature during normal operation

Drink Selection Buttons— The three upper buttons on the indicator panel are for selecting types of drinks (Hot, Iced, Special)

Lock Button— Used to lock buttons on touch panel, and prevent any unwanted dispenses.

Size Buttons— The three lower buttons on the indicator panel are for selecting portion sizes (One Shot, Two Shots, Three Shots)



Operation—Dispensing Cream

1

Place the drink under the dispensing tube.

2

Select the Type of Drink. Press the proper drink selection button to dispense the correct amount of cream. The Hot Drink Selection button is selected by default if no button is pressed.

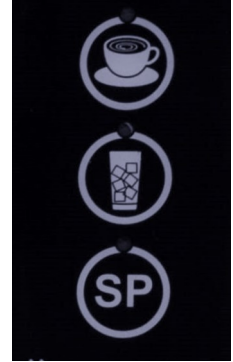

3

Select the size. Press the proper drink size button to dispense the correct amount of cream.

NOTE: The end of the tube may need to be cleaned daily with a clean cloth to prevent buildup which could affect the dispensing of the correct amount of cream.



Operational Flowchart

Silver King Cream Dispenser – Operational Flowchart

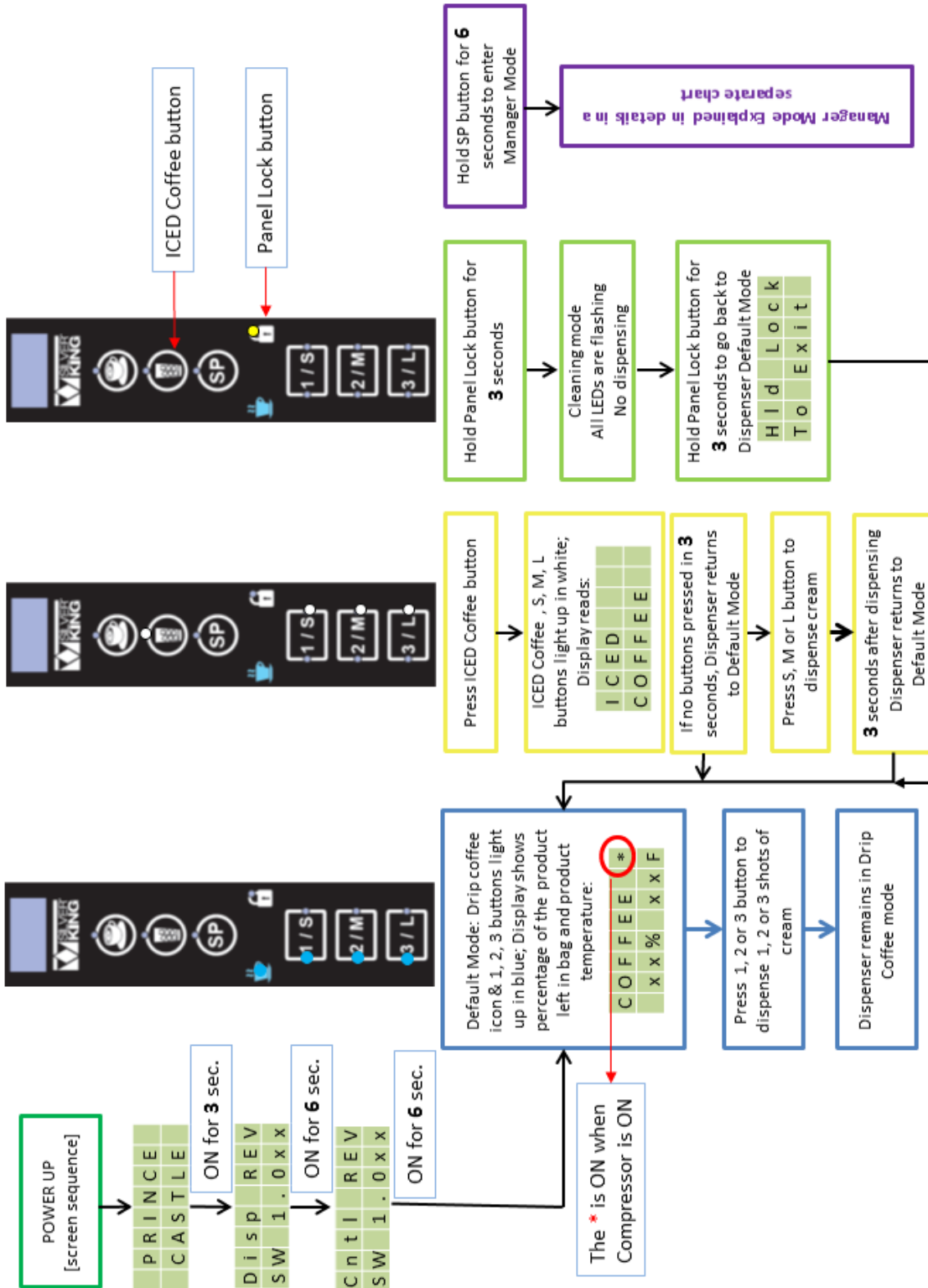

Manager Mode Flowchart

Silver King Cream Dispenser – Manager Mode

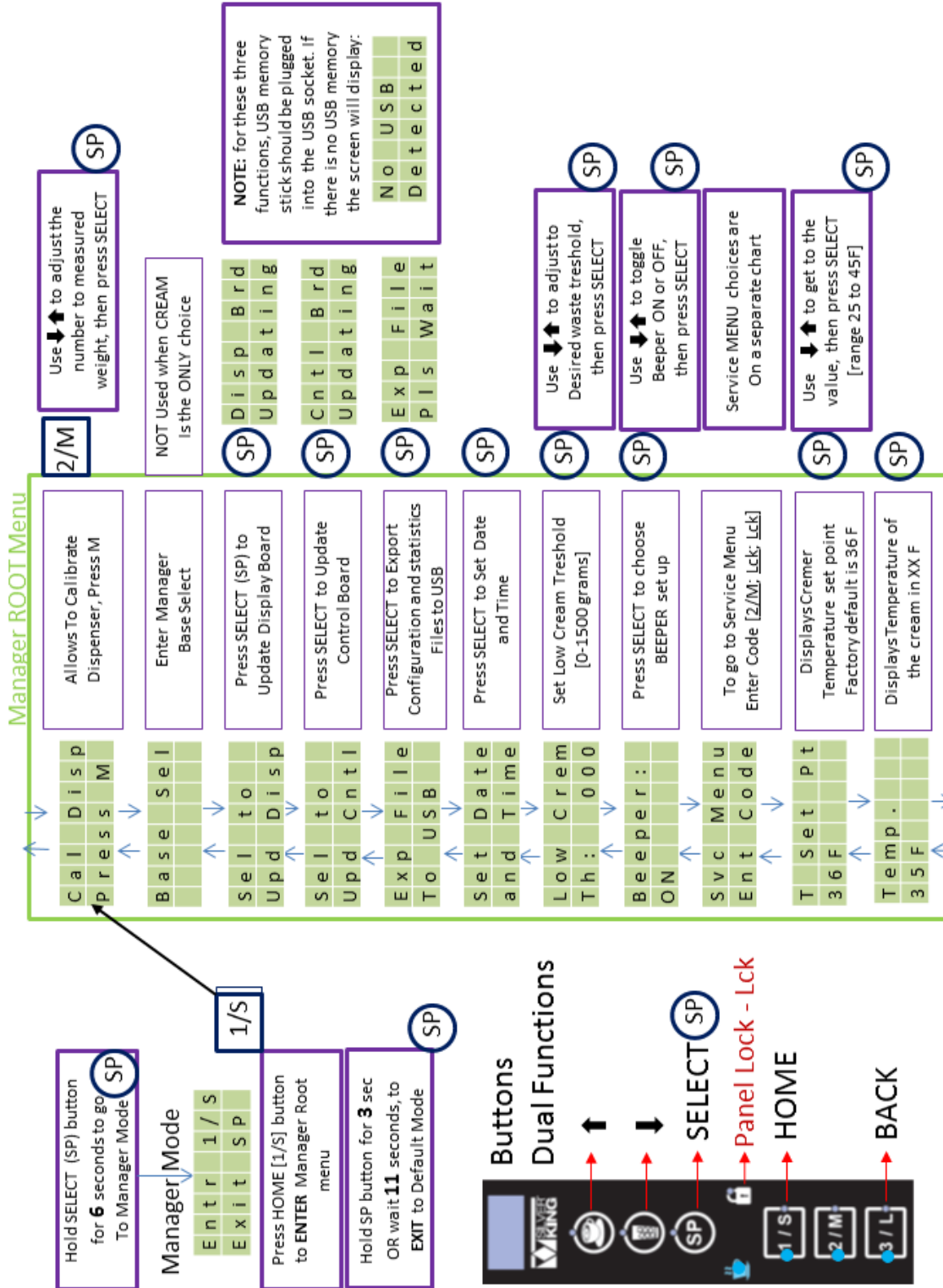

Cleaning the Dispenser

Tools and Supplies Required



Bucket, Clean and Sanitized Towels



Bucket, Soiled Towels



Gastro norm Metal Pan



Gloves, Neoprene



McD All Purpose Super Concentrate (APSC) solution

1

Turn the Creamer off and remove empty creamer bag. Pull and turn valve to release cream tube. Remove the cream bag from the compartment

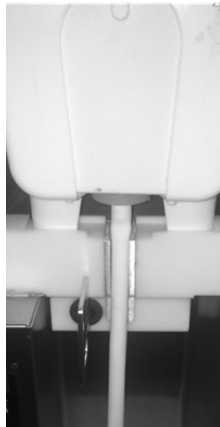

2

Clean drip tray. Take the drip tray to 3 compartment sink to wash, rinse, and sanitize

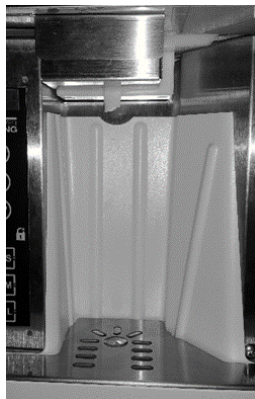

3

Wipe down creamer once it has defrosted completely. Wipe down the cold block and inside of creamer with APSC and Sanitizer Solution.



4

Refill Creamer. Insert a new bag of cream into dispenser. Pull and turn valve to secure cream tube. Replace the drip tray.



Troubleshooting Steps

Master Display Messages		
PROBLEM	PROBABLE CAUSE	SOLUTION
Compressor will not run	No Voltage at wall receptacle	Check circuit breaker or fuse
	Service cord pulled out of wall receptacle	Call for service (888-375-2938).
	Low voltage causing compressor to cycle on overload	Contact power company and confirm that voltage fluctuation does not exceed 10% plus or minus from the nominal rating.
	Power switch is in "Off" position	Turn switch on
	Inoperative Control	Call for service (888-375-2938).
	Compressor stuck	Call for service (888-375-2938).
	Compressor windings open	Call for service (888-375-2938).
	Compressor overload stuck open	Call for service (888-375-2938).
	Relay lead loose	Call for service (888-375-2938).
	Relay loose or inoperative	Call for service (888-375-2938).
	Power cord disconnected from dispenser	Call for service (888-375-2938).
	Faulty cabinet wiring	Call for service (888-375-2938).
Compressor runs but no refrigeration	System out of refrigerant	Call for service (888-375-2938).
	Compressor not pumping	Call for service (888-375-2938).
	Restricted filter drier	Call for service (888-375-2938).
	Restricted capillary tube	Call for service (888-375-2938).
	Moisture in system	Call for service (888-375-2938).
Compressor short cycles	Erratic Control Thermostat	Call for service (888-375-2938).
	Low Voltage	Contact power company and confirm that voltage fluctuation does not exceed 10% plus or minus from the nominal rating.
	Compressor draws excessive wattage	Call for service (888-375-2938).
	Faulty relay	Call for service (888-375-2938).
Compressor runs too much or constantly	Temperature too low	Adjust temperature control
	Erratic Control	Call service technician
	Abnormally high room temperature	Reduce room temperature or relocate dispenser
	Door or lid gaskets not sealing	Adjust or Call for service (888-375-2938).
	System undercharged due to leaks	Call for service (888-375-2938).
	System undercharged from factory	Call for service (888-375-2938).
	System overcharged	Call for service (888-375-2938).
	System not clean	Call for service (888-375-2938).
	Restricted filter drier	Call for service (888-375-2938).
	Restricted capillary tube	Call for service (888-375-2938).

Troubleshooting Steps (Continued)

Master Display Messages		
PROBLEM	PROBABLE CAUSE	SOLUTION
Noisy	Tubing Vibrates	Call for service (888-375-2938).
	Internal compressor noise	Call for service (888-375-2938).
	Compressor vibrating on cabinet frame	Call for service (888-375-2938).
Beverage leaking or not flowing	Tube Kinked	Remove valve and pull tube straight through valve area.
	Valve stuck	Clean valve and valve area or call for service (888-375-2938).

Parts List and Exploded View

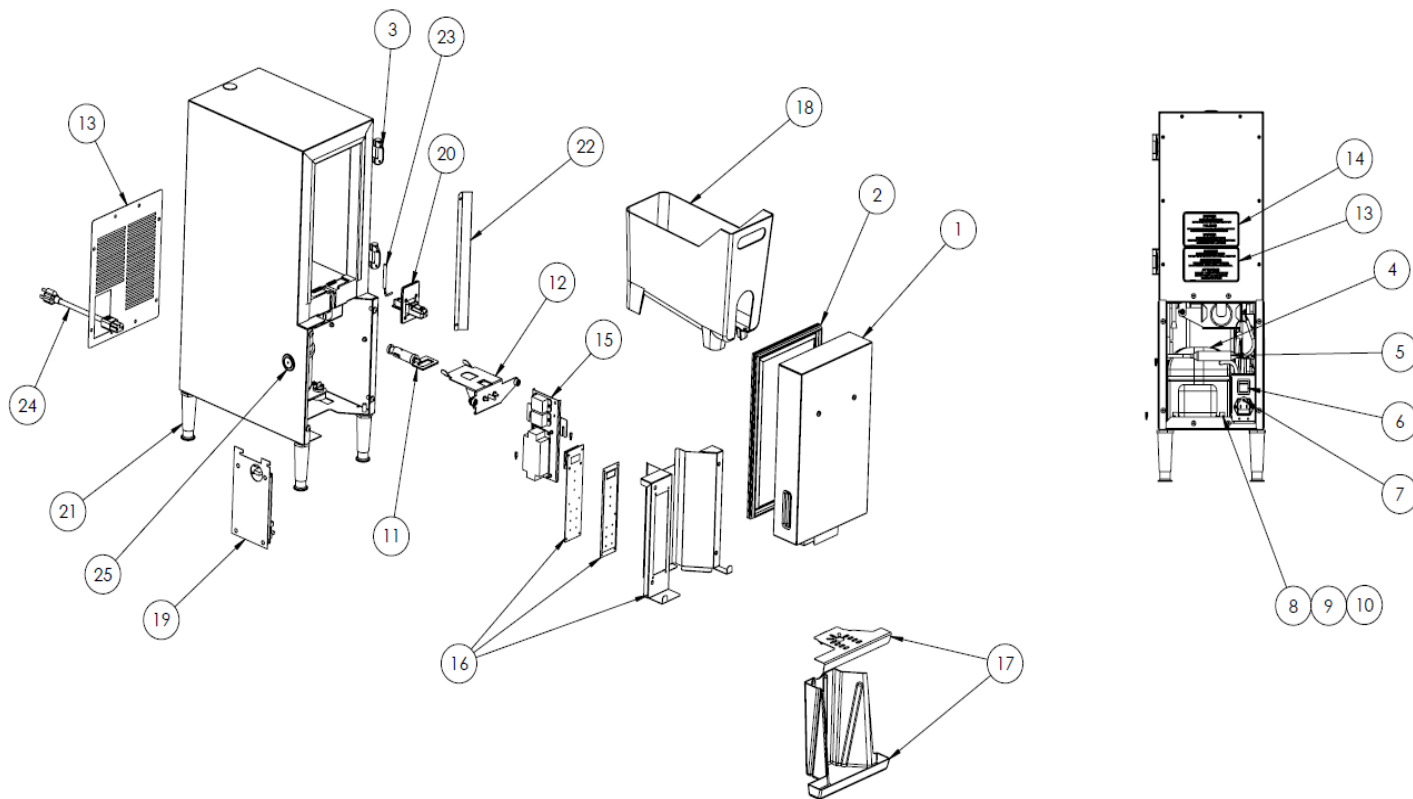

Item	Part Number	Description	Qty
1	366-124S	ASSY DOOR SKMCD1P	1
2	31126S	GSKT DOOR	1
3	25226S	HINGE W/SCREWS & COVERS	2
4	25473S	COMPR 115V/60HZ EM20HHR	1
5	30876S	ASSY EXCHNGR HEAT	1
6	26378	SWITCH ROCKER 115V/230V	1
7	35826	MODULE POWER ENTRY 115V (W/1 FUSE)	1
8	20481P	GROMMET MTG COMPR LONG	4
9	98106P	CLIP HAIRPIN	4
10	22401P	WASHER MOUNT COMPR	4
11	37133S	ASSY VALVE PLUNGER	1
12	366-132S	ASSY RACK SOLENOID	1
13	24048S	LABEL CAUTION HAZARDOUS MOVING	1
14	24050S	LABEL ELECTRIC SHOCK HAZARD	1

Item	Part Number	Description	Qty
15	366-135S	POWER SUPPLY ASSY	1
16	366-139S	ASSY APRON	1
17	366-142S	ASSY TRAY, DRIP - CREAMER	1
18	366-151S	CONTAINER CREAM PLASTIC SINGLE	1
19	366-137S	ELECTRONICS ASSEMBLY	1
20	366-144S	LOAD CELL ASSY	1
21	10314-89	LEG 4" NP FLG FOOT	1
22	24904S	TUBE WELL GUARD	1
23	37364S	PROBE TEMP SKBD3LS	1
24	33883	CORDSET 115V	1
25	37358S	ERGONOMICS PLUG 1" DIA.	1
26	366-149S	BAG GUARD **(NOT SHOWN)**	1

