

Technical Manual and Replacement Parts List

Manufactured especially for Dunkin Donuts



MODEL: SKDC12-ESUS1

1600 Xenium Lane North, Minneapolis, MN 55441-3787
Phone (763) 923-2441
Fax (763) 553-1209
www.silverking.com

SILVER KING®

Table of Contents

Limited Warranty.....	3
Two (2) Year Parts Warranty.....	3
Five (5) Year Compressor Warranty	3
Two (2) Year Labor Warranty.....	3
Introduction.....	4
Unpacking and Set Up.....	4
Inspecting for Shipping Damage	4
Unpacking the Unit.....	4
Precautions.....	4
Location.....	5
Electrical Connections.....	5
Safety.....	5
Installation.....	6, 7
Operation.....	7
Before the First Use.....	7
Initial Set Up.....	7
Display Panel.....	7
Threshold Levels.....	8
Loading the Unit.....	8
Operating the Unit.....	9
Refilling the Product Tanks.....	9
Observing the Current Temperature Inside the Unit.....	10
Changing the Temperature Set Point.....	10
Changing Coolatta Base.....	10
Changing the Dispenser Language.....	10
Cleaning and Maintenance.....	11
Recommended Cleaning Schedule.....	11
Drip Tray Cleaning and Daily Wipe Down.....	12
Cleaning the Product Tanks.....	13
Refrigerated Product Compartment Cleaning.....	14
Cleaning Exterior of Unit.....	14
Daily Calibration – Adjusting Shot Size.....	15
Shot Size Targets.....	16
Troubleshooting Guide.....	17
Ordering Parts/Service.....	18, 19
Wiring Diagram.....	20

Limited Warranty

Silver King, Inc. warrants to the original purchaser of Silver King refrigerated equipment that the equipment shall be free from defects in material and workmanship under normal use and service as outlined in the Technical Manual. This limited warranty shall apply for a period of two (2) years from the date of original purchase. The Compressor will carry an additional three (3) year warranty. All warranties are subject to specific limitations outlined below.

This limited warranty does not apply to repair or replacement required as a result of carelessness, neglect and/or abuse, including improper installation, incorrect voltage supply, tampering with or altering components and/or equipment or failure to perform proper maintenance. Equipment damaged in transit, by fire, flood or an act of God is not covered. This limited warranty does not include freight, handling, installation, labor (following the two (2) year labor warranty period) or other incidental or consequential costs including product and/or economic loss. This limited warranty is in lieu of all other warranties, express or implied, including those of merchantability, and is non-transferable.

Specific provisions of this limited warranty are as follows:

Two (2) Year Parts Warranty

Silver King, Inc. warrants to the original purchaser of new Silver King equipment that such equipment and all parts thereof will be free of defects in material and workmanship, under normal use and service, for a period of two (2) years from the date of original purchase or two (2) years and six (6) months from the date of shipment from the factory, whichever comes first, subject to all terms and conditions herein.

This warranty is limited to repairing or replacing any parts that, at **Silver King's** discretion, are deemed to be defective within the time period covered by this warranty. The two year parts warranty covers reasonable freight and handling charges. It does not cover special handling charges or expedited means for transport. Use of non-OEM parts may, at **Silver King's** discretion, void this warranty. If approved, warranty credit for non-OEM parts will be issued at the OEM cost. Replacement parts sold separately are warranted for 90-days from date of purchase.

Wear items not included: product containers and lids (p/n [37068](#), [37069](#), & [37070](#)), drip tray (p/n [37281](#)) and cup guides (p/n [37436](#)) are considered wear items and are not included under the warranty.

Five (5) Year Compressor Warranty

Silver King, Inc. warrants to the original purchaser for a period of five (5) years from the date of original purchase or five (5) years and six (6) months from the date of shipment from the factory, whichever comes first, that it will replace the compressor with one of similar design and capacity, exclusive of delivery and installation charges, if it is found to Silver King's **satisfaction to be inefficient or inoperative due to defects in material or factory workmanship. It is the owner's** responsibility to return the serial plate of the defective compressor, or at Silver King's **option the complete compressor, to** the factory. Failure to do so will void the warranty.

Two (2) Year Labor Warranty

Silver King warrants to the original purchaser for a period of two (2) years from the date of purchase or two (2) years and six (6) months from the date of shipment from the factory, whichever comes first, a limited service labor warranty on Silver King refrigerated equipment subject to the following terms:

A factory issued Service Authorization Number must be obtained prior to work being performed under the labor warranty. Call your supplier or Silver King. Claims submitted without a Service Authorization Number will be paid at Silver King's discretion.

The labor warranty includes standard straight time labor charges in accordance with **Silver King's** Labor Warranty Guidelines and reasonable travel time, as determined by Silver King.

The warranty does not cover original installation, startup, normal adjustments or maintenance. Normal adjustments and maintenance include, but are not limited to; temperature control adjustments, temperature indicator calibrations, coil and filter cleaning, condensate drain cleaning. A second service call for a related failure is not covered.

Use of refrigerants other than specified on the equipment serial plate voids the warranty.

All claims must include: model and serial number of equipment, date of purchase, date of failure, and a copy of the service invoice detailing the defect and service performed. No claim will be processed without this information. All claims must be filed within 60 days from date of service.

Introduction

The 3 product Dairy Dispenser is designed to house, refrigerate and dispense three dairy products such as 2%, whole, or skim milk, and/or cream. The unit has been set to maintain product within a temperature range of 33 to 40 °F. The Dairy Dispenser consists of a refrigerated compartment containing three removable containers for the dairy products, three solenoid-actuated pinch valves that control gravity-induced flow through plastic discharge tubes and an operator interface that allows simple selection of amounts of selected product. The unit also contains a weight measuring sensor to ensure proper product volume dispense regardless of the amount of product in the container. There is no need to manually calibrate the unit when product levels vary.

Unpacking and Setup

Inspecting for Shipping Damage

Examine the shipping container immediately upon receipt. Any damage to the container or equipment due to shipping should be reported to the transportation company immediately. Claims should be filed within twenty-four (24) hours. Shipping damage is not the responsibility of Silver King.

Unpacking the Unit

This unit is shipped in a corrugated box for protection. When multiple units are shipped to a single location, the unit are boxed and then placed on a skid. The skid is shrink-wrapped to attach the boxes to the skid. Carefully remove the unit from the shipping box. Be sure to follow any orientation or caution labels on the box.

PRECAUTIONS BEFORE USING THIS PRODUCT

- This appliance is not intended for use by persons (including children) with reduced physical, sensory or mental capabilities, or lack of experience and knowledge, unless they have been given supervision or instruction concerning use of the appliance by a person responsible for their safety.

- Use caution when cleaning the condenser, the fins are very sharp.
- For units with a dual hertz rating, no adjustments are required for normal operation.
- If the supply cord is damaged, it must be replaced by the manufacturer, its service agent or similarly qualified persons in order to avoid a hazard.
- This refrigeration unit is not intended to be used at altitudes higher than 2000 meters.
- Do not store explosive substances such as aerosol cans with a flammable propellant in this appliance.
- Use caution when moving, installing, maintaining and using this refrigeration device to avoid either damaging the refrigerant tubing or increasing the risk of a leak.
- All component parts must be replaced with like components and all servicing must be done by factory authorized service personnel, so as to minimize the risk of possible ignition due to incorrect parts or improper service.



WARNING: This product can expose you to chemicals including lead, which are known to the State of California to cause cancer, birth defects, or other reproductive harm.

Location

When locating this unit, convenience and accessibility are important considerations, but the following factors must be observed:

1. Proximity to a 3-prong 115VAC receptacle for grounding
2. No clearance is required on the sides or back of the unit. The unit must be operated with the legs in place and the top of the unit must be clear of obstruction.

The unit may be located in the drive-through area, on the front counter or in the drink area, whichever is more convenient.

Electrical Connections

Prior to connecting the unit to power, be sure to check the data plate, located on the inside of the cabinet, for required voltage. The specifications on the data plate supersede any information contained in this manual.

The standard unit is equipped with a seven (6) foot (2) inch power cord extending from the bottom of the unit. The unit requires a 115 Volt, 60 Cycle, 1 Phase properly grounded electrical receptacle protected with a 15 or 20 ampere fuse or breaker. The power cord comes with a 3 prong plug for grounding purposes. Any attempt to cut off the grounding spike or to connect to an ungrounded adapter plug will void the warranty, **terminate the manufacturer's responsibility and could result in serious injury.**

Safety

FOR HYDROCARBON UNITS ONLY (R290)

Danger – Risk of fire or explosion. Flammable refrigerant used. To be repaired only by trained service personnel. Do not puncture refrigeration tubing.

Danger – Risk of fire or explosion. Flammable refrigerant used. Do not use mechanical devices to defrost refrigerator/freezer. Do not puncture refrigeration tubing.

Caution – Risk of fire or explosion. Flammable refrigerant used. Consult repair manual/owner's guide before attempting to service this product. All safety precautions must be followed.

Caution – Risk of fire or explosion. To be repaired only by trained service personnel. Use only Silver King approved replacement parts. Flammable refrigerant used.

Caution – Risk of fire or explosion. Dispose of properly in accordance with federal or local regulations. Flammable refrigerant used.



CAUTION: Risk of Electric Shock

- Always unplug the power cord before servicing the unit to avoid electric shock.
- Unit **MUST** be plugged into a 3 prong plug for grounding. Cutting off the grounding spike on the power cord could result in electric shock to the operator during operation.
- Unit must be plugged into a 15 or 20 ampere fuse or breaker protected circuit. Use of a larger fuse or breaker could result in damage to the unit and electric shock to the operator.



Moving and/or Hot Parts

- Some parts may remain hot even after being unplugged. Always use caution when servicing.



Possible Back Injury

- Assistance should be utilized when moving this piece of equipment.
- Be sure to lift with your legs and not your back when lifting this unit.

Installation



CAUTION: To avoid injury, the following steps should be performed by two people.

Remove the unit from its packaging material and place it near the mounting location and install the four legs underneath the unit. The unit should be oriented such that the power cord reaches the intended power outlet. Remove the plastic protective film from the stainless steel surfaces and wipe all the surfaces with a mild soap water solution.

In order for the unit to function properly, it is important that the unit be level front to back and from side to side.

Once the machine is in place and has been leveled, install the display cable and hand tighten the threaded connectors. See Figure 1.



Figure 1. Display Cable

Next, install the drip tray and the cup guide. Hand the drip tray on the bottom two screws on the front apron of the unit. See Figure 2. Slide the cup guide into position and secure it on the upper two screws, as shown in Figure 2.



Figure 2. Drip Tray and Cup Guide

Then plug in the power cord on the bottom of the unit, at the right rear, as shown in Figure 3. Run the cord along the rear of the shelf and plug it into the designated outlet.

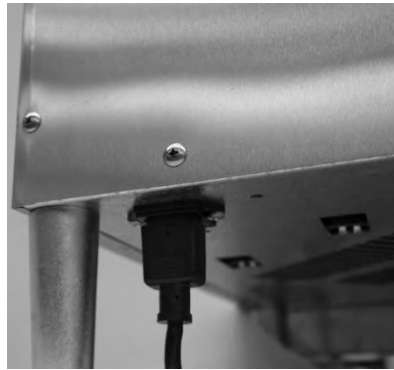

Figure 3. AC Power Cord Connection

Operation

Before the First Use

Daily Calibration Procedure must be performed before the unit is put into operation. See Page 16 (Daily Calibration – Adjusting Shot Size) for details.

Initial Startup

This unit operates at ambient temperatures between 32° F (0° C) and 78° F (26° C).

After completing the installation requirements, the unit is ready to start. Turn on the power switch (left side of unit near the front). The display panel should light up and the fan should turn on in the back of the unit. Allow the unit to run for approximately one hour before loading it with product. The internal temperature should be between 33° F and 40° F.

Display Panel

The display panel, shown in Figure 4, contains an LCD display along with the controls for dispensing product. Note: when the unit is first powered up, the LED'S above the Milk, Cream and Skim buttons are flashing. This is to indicate that the containers are either low or empty and need to be filled.



Figure 4. Display Panel

Threshold Levels

The Milk and Skimmed Milk levels are set to 600gm and the Cream level to 850gm. The unit goes into lockout when the product in the tanks is less than or equal to these amounts.

Controls

The bottom portion of the Display Panel is used to control the dispensing of products. Descriptions of these controls are:

- Drink Size – The top row of buttons is used to identify what size drink is being dispensed.
- Drink Type – The middle row of buttons is used to select what type of drink is being dispensed.
- Product – The bottom row of buttons is used to choose which product is to be dispensed.

Loading the Unit

Make sure that the unit has reached its internal operating temperature by running it without product for about an hour.

Perform the following procedure to clean and sanitize the unit.

Step	Action
1	Using clean gloves, attach new dispensing tubes to the bottom of the product tanks.
2	Open the front and top access doors of the unit.
3	Open the product valves by pulling them out slightly and turning them counter-clockwise a quarter of a turn. (Parallel to the dispensing tube slot.)
4	Place the three product tanks into the unit in the proper order. Make sure the dispensing tubes are properly seated in their slots.
5	Move the product valves into position by pulling them out slightly and turning them clockwise a quarter of a turn so that they pinch the dispensing tubes.
6	Open the cover on the top of each tank and fill with fresh product. Note: do not fill containers above the fill line. (See Figure 5.)
7	Close the covers on the top of the tanks.
8	Close the top access door and then close the front door of the unit.



Warning: All product tanks must be cleaned, sanitized and air dried before use.

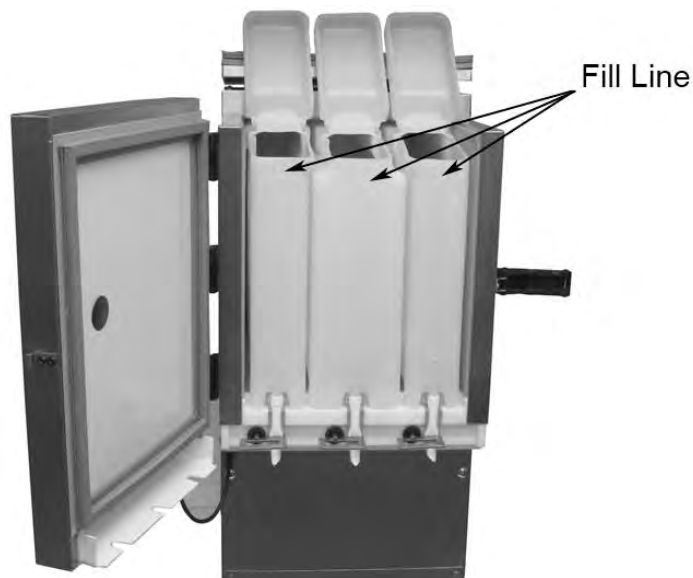

Figure 5: Product Tanks Open

Operating the Unit

To dispense a drink, perform the following procedure.

Step	Action
1	Place the drink under the appropriate dispensing tube.
2	Select the type of product required for the drink, (bottom row), then go to Step 3 or Step 4, depending on the type of drink required. If no product is specified, Cream will be dispensed. This default can be changed in the Manager menu
3	For coffee, press the proper drink size button (top row) to dispense the proper amount of product.
4	For Latte, Cappuccino or Coolatta, press the appropriate button (middle row), then press the proper size button (top row) to dispense the drink.

Refilling the Product Tanks

To refill the product tanks while in the unit, perform the following procedure.

Step	Action
1	Open the front and top access door of the unit.
2	Open the lid of the product tank to be refilled.
3	Refill the tank with the appropriate product for that tank. NOTE: Do not fill containers above fill line. (See Figure 5)
4	Close the tank lid.
5	Close the top access and front access doors of the unit.
6	The unit is now ready to resume normal operation.

Observing the Current Temperature Inside the Unit

To see the current temperature inside the unit, press the up or down arrow until the Temperature is displayed.

Changing the Temperature Set Point

If Product temperature is not within spec (33 - 40 degrees) perform the following procedure to adjust cabinet temperature accordingly. The unit follows a 1:1 ratio. For example, if product temp is 32 degrees (1 degree below product temp spec) adjust the Temp Set Point UP by one degree.

Step	Action
1	On the indicator panel, press the up or down arrow until the Config Mode Entr Btn Combo is displayed.
2	Press the X Size button (this is the button combo)
3	Press the Up or Down arrow until the term "Temp Set Point" is displayed.
4	Press the Select button.
5	Press the Up or Down arrow again to choose the desired temperature (between 35 and 40°).
6	Press the Select button.
7	Press the Home button to return to the main menu.

Changing Coolatta Base

The Coolatta drink base comes in two types, coffee and neutral. To set the unit for the type used, perform the following procedure.

Step	Action
1	On the indicator panel, press the up or down arrow until the Config Mode Entr Btn Combo is displayed.
2	Press the X Size button (this is the button combo).
3	Press the Up or Down arrow until the term "Base Selection" is displayed.
4	Press the Select button.
5	Press the Up or Down arrow again to choose either the Coffee or Neutral selection.
6	Press the Select button.
7	Press the Home button to return to the main menu.

Changing the Dispenser Language

Multiple languages will be available in the future for this unit. At that time a procedure will be added to allow the operator to change the language on the unit.

Cleaning and Maintenance

Because this unit is intended for use with dairy products, it must be cleaned and sanitized prior to the first use, and every 72 hours during regular use. The unit goes into a cleaning lockout every 72 hours and will stay locked until the containers have been removed for cleaning.

The following items are recommended for sanitary operation of the unit.

- Immediately cleanup all product spilled during the filling process or during drink preparation.
- At various times throughout the day, wipe down the valve assembly with a towel moistened with sanitizer solution an empty and clean the drip tray.
- Empty, clean and sanitize the entire unit every 72 hours.
- New product dispensing tubes **MUST** be installed each time a tank is cleaned and reloaded.

Recommended Cleaning Schedule

The following table is a recommended cleaning schedule for the unit. Follow local schedules, if applicable.

Dispenser Assemblies	Frequency
Drip Tray	Daily
Valve Area	Daily
Dispensing Valves	Every 72 hours or as needed
Exterior	Weekly
Product Tank	Whenever tank is removed and refilled or every 72 hours.
Product Tank Compartment	Whenever tank is removed and refilled or every 72 hours.
Condenser	Every six months (remove back panel and clean dust and debris out of condenser coil).



Warning: This unit **MUST** be cleaned on a daily basis to ensure sanitary operation.

Drip Tray Cleaning and Daily Wipe Down

Step	Action
1	Remove the drip tray by lifting it up and off of the two mounting screws.
2	Rinse the drip tray in lukewarm potable water.
3	Place the tray in hot water at a minimum water temperature of 140°F or 60°C. A good quality general-purpose soap should be added to the hot water at the concentrations recommended by the detergent supplier.
4	Wash the tray thoroughly using a bottlebrush to reach all corners and crevices. If a dishwasher is available, this step may be carried out by placing the tray in the dishwasher and washing on the pot cycle.
5	After washing, rinse the tray thoroughly with lukewarm potable water.
6	Turn the tray upside down and let it air dry.
7	While cleaning the drip tray, wipe down the front apron, the valve area and the bottom of the door to make sure there are no product splashes sitting on these surfaces.
8	Wipe down the area under the door and under the valve block, as shown in Figure 6.



Figure 6. Area to be Cleaned

Cleaning the Product Tanks

Step	Action
1	Turn off power to the unit, by placing the power switch in the OFF position.
2	Open the front and top access doors of the unit.
3	Place an empty cup under the dispensing tube to catch any remaining product.
4	Open the product valve by pulling it out slightly and turning it counter-clockwise a quarter of a turn. (Parallel to the dispensing tube slot.)
5	Repeat Steps 3 & 4 for the other two product tanks, if necessary
6	Remove the dispensing tubes from the tank(s) and discard. (See Error! Reference source not found.)
7	Place the tanks and covers in the three compartment sink, filled with a Dunkin approved dairy dispenser detergent. Let tanks soak for 5 minutes. NOTE: Make sure to follow manufacturer's specifications.
8	Thoroughly brush-clean the tanks and covers. Make sure all product film is removed from internal and external surfaces.
9	Thoroughly rinse the tanks and lids in warm water.
10	Rinse the tanks and covers in the sanitizing solution for a minimum of one (1) minute.
11	Remove containers and lids from sanitizing solution, shake to remove excess solution and place the parts on a clean, dry surface to air dry.
12	With an approved sanitizing solution, thoroughly clean the dispensing tube slots and dispensing valves. Allow to air dry.

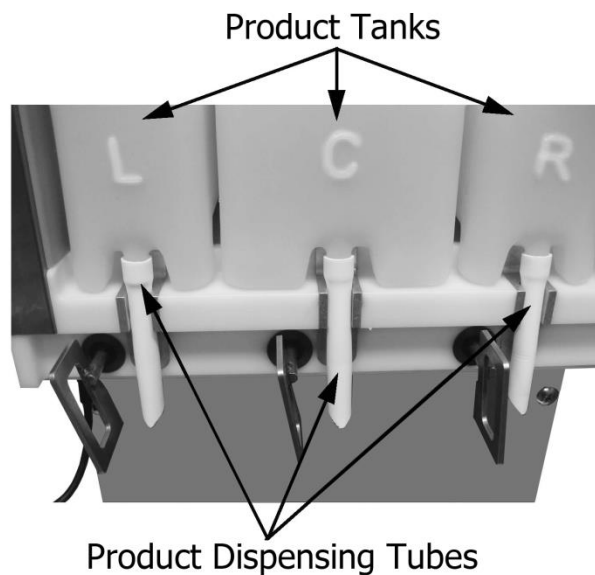

Figure 7. Dispensing Tubes and Product Tanks

Refrigerated Product Compartment Cleaning

Each time a new product tank is loaded, check the refrigerated product compartment for ice buildup and dairy spillage. If ice is noticeable, perform the following procedure to remove it.

Step	Action
1	Turn off power to the unit, by placing the power switch in the OFF positions.
2	Open the front and top access doors of the unit and remove the product tank(s).
3	Check the refrigerated product compartment for ice buildup. If ice buildup is noticeable, leave the door open for about 15 min. to allow the ice to soften. Remove the ice by hand. NEVER use sharp objects to remove ice.
4	Wipe down the interior with a clean, soft cloth.
5	Dry thoroughly.
6	Close the front and top access doors of the unit.
7	Turn on power to the unit and let it run for 15-30 min. until the unit is cold.
8	Replace the product tank(s).

Cleaning Exterior Of Unit

To clean the exterior of the Unit, perform the following procedure.

Step	Action
1	Press the up or down arrow until the display reads Panel Disable Press Select.
2	Press Select and the screen reads Panel Disable HLD HOM to Ext.
3	Use a soft, clean, dry cloth to wipe down the exterior surface of the unit. NOTE: Never use abrasive materials or cleaners on the exterior of the unit.
4	Wash the stainless steel surfaces of the unit with warm, soapy water.
5	Rinse the surfaces with warm water.
6	Wipe the stainless steel surfaces dry with a clean, soft cloth prevent water spotting. NOTE: stainless steel polish may be used, but is not required. Do not spray directly on the unit. Wet the cloth with the polish.
7	Hold your finger on the Home button for 2-3 seconds to exit Panel Disable mode.

Daily Calibration - Adjusting Shot Size

The dispense accuracy of the unit needs to be checked daily to ensure that the unit is dispensing within the required specifications. Perform the following procedure to adjust the shot size.

Step	Action
1	If unit has been idle (no shots taken for over a half hour) take one shot of size Medium (coffee) for each product to exercise the tubes.
2	Place a cup on the external scale and press tare.
3	Place the cup under the proper product tube.
4	Select the product to be dispensed and then press the "M" button to dispense product amount for a medium coffee.
5	Weigh the product on the external scale.
6	If the shot weight is within the specified range listed in the Redbook (41-51 g) then you can move on to the next product. If the shot weight is outside of the specified range then a simple calibration is required. To calibrate the unit, follow Steps 7 to 11.
7	Repeat Steps 2 and 3, then go to the Calibration menu by pressing the Down arrow once, the display will read Calibrate Disp Select Product.
8	Press the button of the product you wish to calibrate (Milk, Cream or Skim) and then press the M button. NOTE: make sure the cup is under the valve at this time, because a medium sized shot is dispensed.
9	Weigh the cup on the external scale.
10	The display now reads "Enter Weight 46 Grams". Press the Up or Down arrow until the value on the display matches the weight that you measured using the external scale and then press select.
11	The display again reads "Calibrate Disp Select Product". You may now select the next product to calibrate or press the Home button to return to normal operation.

Shot Size Targets

With machine set to COFFEE Base ALL SHOTS ARE LISTED AND MEASURED IN GRAMS				
		MIN	TARGET	MAX
COFFEE	XS	13	15	17
	SM	27	31	34
	MED	41	46	51
	LG	54	61	67
	XLG	68	76	84
LATTE	SM	164	183	202
	MED	247	275	303
	LG	329	367	404
CAPPUCCINO	SM	109	122	135
	MED	164	183	202
	LG	219	244	269
COOLATTA	XS	54	61	67
	SM	109	122	135
	MED	163	183	202
	LG	217	243	269

With machine set to NEUTRAL Base ALL SHOTS ARE LISTED AND MEASURED IN GRAMS				
		MIN	TARGET	MAX
COFFEE	XS	13	15	17
	SM	27	31	34
	MED	41	46	51
	LG	54	61	67
	XLG	68	76	84
LATTE	SM	164	183	202
	MED	247	275	303
	LG	329	367	404
CAPPUCCINO	SM	109	122	135
	MED	164	183	202
	LG	219	244	269
COOLATTA	XS	41	46	50
	SM	82	91	100
	MED	123	137	150
	LG	164	182	200

Troubleshooting Guide

Complaint	Cause	Solution
Compressor will not run	<ol style="list-style-type: none"> 1. No voltage at wall receptacle 2. Service cord pulled out of wall receptacle 3. Low voltage causing compressor to cycle on overload 4. Containers are in the wrong position 5. Power switch is in "Off" position 6. Power cord disconnected from unit 7. Inoperative control 8. Compressor stuck 9. Compressor windings open 10. Compressor overload stuck open 11. Relay lead loose 12. Relay loose or inoperative 13. Faulty cabinet wiring 	<ol style="list-style-type: none"> 1. Check circuit breaker or fuse 2. Replace 3. Contact power company and confirm that voltage fluctuation does not exceed 10% plus or minus from the nominal rating 4. Check container positions (L, C, R) 5. Turn switch on 6. Reinsert cord into unit receptacle 7. Call service technician 8. Call service technician 9. Call service technician 10. Call service technician 11. Call service technician 12. Call service technician 13. Call service technician
Compressor runs but no refrigeration	<ol style="list-style-type: none"> 1. System out of refrigerant 2. Compressor not pumping 3. Restricted filter drier 4. Restricted capillary tube 5. Moisture in system 	<ol style="list-style-type: none"> 1. Call service technician 2. Call service technician 3. Call service technician 4. Call service technician 5. Call service technician
Compressor short cycles	<ol style="list-style-type: none"> 1. Erratic control thermostat 2. Faulty relay 3. Low voltage 4. Compressor draws excessive wattage 	<ol style="list-style-type: none"> 1. Call service technician 2. Call service technician 3. Contact power company and confirm that voltage fluctuation does not exceed 10% plus or minus from the nominal rating 4. Call service technician
Compressor runs too much or constantly	<ol style="list-style-type: none"> 1. Temperature too low 2. Erratic control 3. Abnormally high room temperature 4. Containers not in place 5. System undercharged due to leaks 6. System undercharged from factory 7. System overcharged 8. System not clean 9. Restricted filter drier 10. Restricted capillary tube 	<ol style="list-style-type: none"> 1. Call service technician 2. Call service technician 3. Reduce room temperature 4. Insert containers and fill with product 5. Call service technician 6. Call service technician 7. Call service technician 8. Call service technician 9. Call service technician 10. Call service technician
Noisy	<ol style="list-style-type: none"> 1. Tubing vibrates 2. Internal compressor noise 3. Compressor vibrating on cabinet frame 	<ol style="list-style-type: none"> 1. Call service technician 2. Call service technician 3. Call service technician
Unit is out of calibration after refill	<ol style="list-style-type: none"> 1. Containers are in the wrong position 	<ol style="list-style-type: none"> 1. Check container positions (L, C, R)

Ordering Parts/Service

Contact Silver King Refrigeration at (800) 328-3329, prompt 1, for technical assistance.

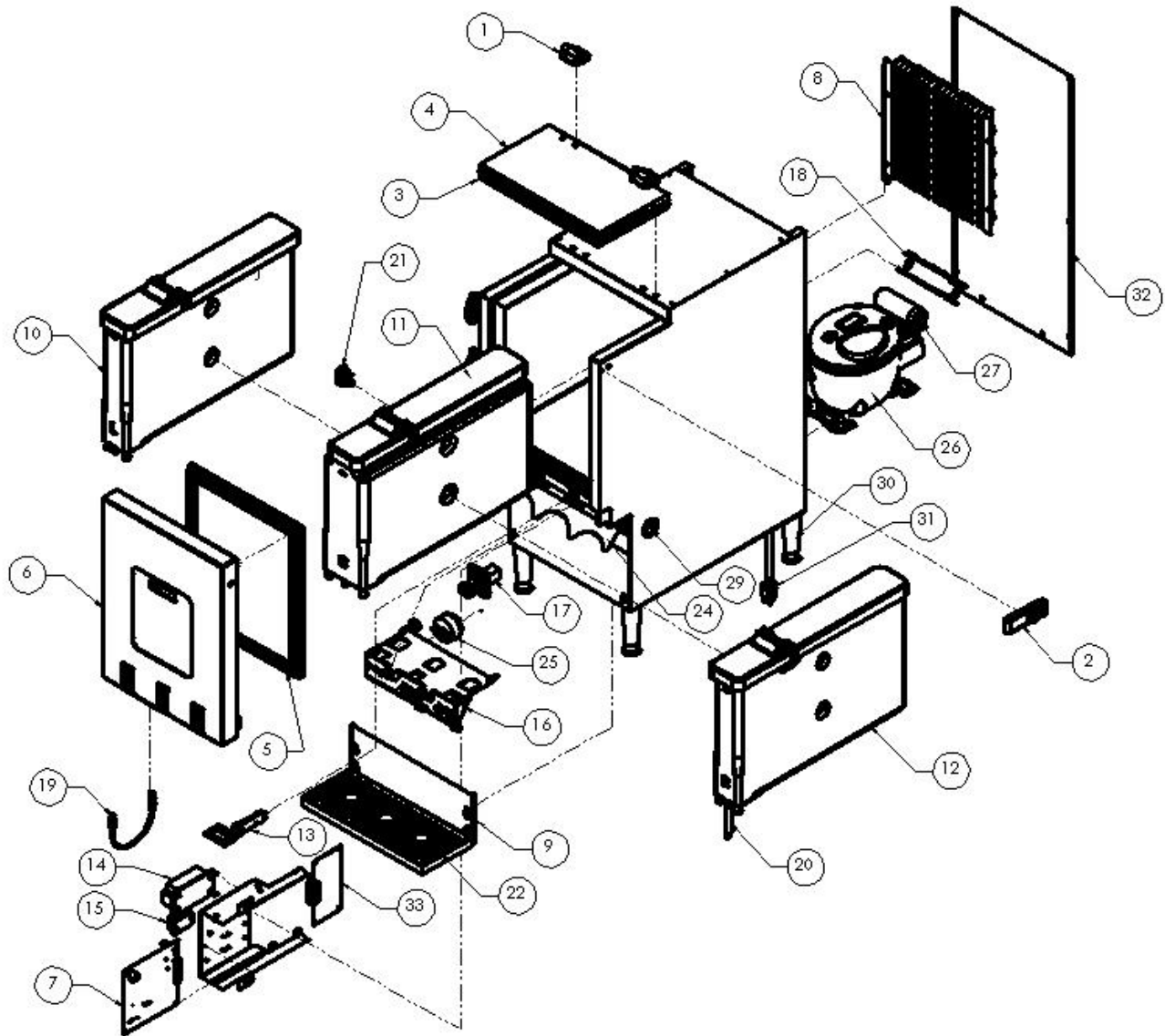

REPLACEMENT PARTS LIST - SKDC12-ESUS1

ITEM NO.	PART DESCRIPTION	PART NO.
1	HINGE W/ SCREWS AND COVERS	25226
2	LATCH	25227
3	LID GASKET	36954
4	LID ASSEMBLY	36955
5	DOOR GASKET	36956
6	DOOR ASSEMBLY	36957
7	CONTROL BOARD	36992
8	CONDENSER COIL	37016
9	PLATFORM FOR DRIP TRAY	37052
10	CONTAINER ASSEMBLY LEFT	37068
11	CONTAINER ASSEMBLY CENTER	37069
12	CONTAINER ASSEMBLY RIGHT	37070
13	VALVE PINCH ASSEMBLY	44349
14	POWER SUPPLY	10333-10
15	RELAY	37147
16	SOLENOID RACK BRACKET ASSEMBLY	37461
17	LOAD CELL ASSEMBLY	37168
18	CONDENSER FAN 115V/230V	43832
19	CONNECTOR DOOR DISPLAY	37210
20	3" TUBES (CARTON OF 300)	37222
21	POWER SWITCH	39564
22	DRIP TRAY	37281
23	TEMPERATURE PROBE (NOT SHOWN)	37364
24	UPPER CUP GUIDE	37436
25	SOLENOID	39543
26	COMPRESSOR KIT 115V/60HZ (W/ELECTRICALS AND DRIER)	11700-12
27	ELECTRICAL KIT 115V (RELAY & OVERLOAD)	11701-12
28	CAPILLARY TUBE (NOT SHOWN)	99035
29	USB HOLE PLUG 1" DIA	37358
30	4" LEG KIT	38493
31	POWER CORD 115V TYPE B	33883
32	BACK PANEL	36710
33	CONNECTION BOARD	36993
34	HARNESS CONTROL BOARD TO DOOR (NOT SHOWN)	37452

FORM 45184 REV E

WHEN ORDERING REPLACEMENT PARTS, PLEASE PROVIDE MODEL AND SERIAL NUMBERS.

