

# Technical Manual and Replacement Parts List

---

Model **SKF27B/CQ**  
Freezer

**SILVER KING REFRIGERATION INC.**

1600 Xenium Lane North, Minneapolis, MN 55441-3787  
Phone (763) 923-2441



Specifications Subject to Change Without Notice.



**TECHNICAL MANUAL**  
**SILVER KING FRONT BREATHING FREEZER**  
**MODEL SKF27B/CQ**

Thank you for purchasing Silver King food service equipment. Our goal is to provide our customers with the most reliable equipment in the industry today. Please read this manual and the accompanying warranty information before operating your new Silver King unit. Be sure to complete and mail the warranty card within 10 days of purchase to validate your warranty.

**INSPECT FOR DAMAGE AND UNCRATE**

Upon delivery of your new Silver King unit, uncrate at once to examine and test for possible damage following the instructions printed on the exterior of the container. Report any damages to the carrier responsible for transportation and promptly present a claim for any evidence of mishandling. Save all packaging materials if a claim must be filed.

**INSTALLATION**

The stainless steel exterior of the cabinet has been protected by a plastic covering during manufacturing and shipping. This covering can be readily stripped before installation. After removing this covering, wash the interior and exterior surfaces using a warm, mild soapy water solution and a sponge or soft cloth. Rinse afterward with clean water and wipe dry. Do not use chlorinated cleaners.

**Location:**

When locating your new Silver King unit, convenience and accessibility are important considerations, but the following installation guidelines must be observed;

- Always avoid locating the unit adjacent to an oven, heating element or hot air source which could adversely affect the performance of the unit.
- The unit must be level.
- For proper ventilation, the bottom front of the unit must not be obstructed.

**Legs/Casters:**

This model comes with Casters. To install them, tilt the unit and thread the Casters into the four Rivnuts in the bottom of the cabinet. Make sure that they are installed tightly to prevent future thread wear.

**Condenser Filter Screen**

On models with a base, the Condenser Filter Screen is factory mounted behind the Base Grill. Remove the Base Grill and ensure that the Condenser Filter Screen is in place. Do not operate the unit without the filter screen installed!

**Shelves:**

Inside the unit you will find Shelves and a plastic bag containing Shelf Supports. The Shelf Supports with the "tang" go on the rear Pilasters. This shelf system allows for easy adjustment to suit your needs.

**Door Adjustment:**

Should the door ever require straightening, loosen the screws on the hinges, square the door with the cabinet and retighten the screws.

**Electrical Connections:**

Be sure to check the data plate, located on the liner of the cabinet, for required voltage prior to connecting the unit to a power source. The specifications on the data plate supersede any future discussion.

The standard unit is equipped with an eight (8) foot power cord that requires a 115 Volt, 60 Cycle, 1 Phase **properly grounded** electrical receptacle. The power cord comes with a 3 prong plug for grounding purposes. Any attempt to cut off the grounding spike or to connect to an ungrounded adapter plug will void the warranty, terminate the manufacturers responsibility and could result in serious injury.

The circuit must be protected with a 15 or 20 ampere fuse or breaker. The unit must be isolated on a circuit and not plugged into an extension cord.

**OPERATION**

**Initial Start Up:**

After satisfying the installation requirements, the unit is ready to start. The unit will start when the power cord is connected to the required power source. If the compressor does not start when the unit is initially plugged in, check to make sure that the temperature control is not in the 'off' position. Allow the unit to run a minimum of two hours before loading it with product. When loading the unit with product, take care not to block the air flow at the back of the cabinet as this would affect the performance of the cabinet.

**Temperature Control:**

The Temperature Control is located on the back wall of the cabinet liner and is factory set to maintain an average cabinet temperature of 5 Deg. F. To obtain colder temperatures turn the Temperature Control knob clockwise and visa versa. Allow the unit a minimum of one hour to respond to a control setting adjustment.

**Defrost:**

Your Silver King unit is an automatic defrost unit. No additional plumbing is required. Automatic defrosting is accomplished by a defrost heater and timer. Frost buildup on the evaporator coil is cleared at six hour intervals. Defrost water is collected in a pan located in the compressor compartment where it is evaporated into the room air. It is important that the unit be level so the condensate can drain properly.

**MAINTENANCE**

Preventative maintenance is minimal although these few steps are very important to continued operation and maximizing the life of the appliance.

**Cabinet Surfaces:**

The cabinet interior and exterior are stainless steel. These surfaces should be cleaned periodically with a solution of warm water and mild soap. After cleaning the surfaces should be rinsed with clean water and wiped dry with a soft cloth. Stainless steel cleaners can also be used. Should a surface become stained, do not attempt to clean with an abrasive cleaner or scouring pad. Use a soft cleanser and rub with the grain of the metal to avoid scratching the surface. Always rinse well and dry after cleaning. Do not use chlorinated cleaners.

**Condenser**

Periodically the Condenser Filter Screen must be cleaned. On cabinets with a base, the Condenser Filter Screen is located behind the Base Grill. Simply remove the Base Grill to gain access to it. Clean the Condenser Filter Screen by rinsing it in a stream of water. Dry the screen by tapping it on a counter or floor. On the models with a base, replace the Condenser Filter Screen by placing it onto the angled support and reattaching the Base Grill. Do not operate the unit without the filter screen installed!

**Door Gasket**

The Door Gasket will collect dirt and should be wiped clean with a warm, mild soapy water solution to extend its life and assure maximum cabinet performance and life.

MODEL \_\_\_\_\_ SERIAL NO. \_\_\_\_\_ DATE INSTALLED \_\_\_\_\_

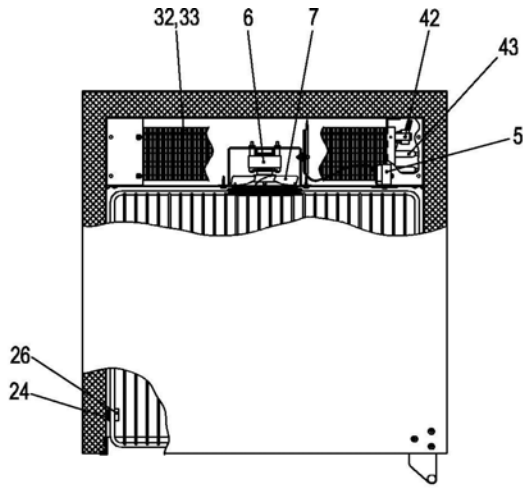

TOP VIEW

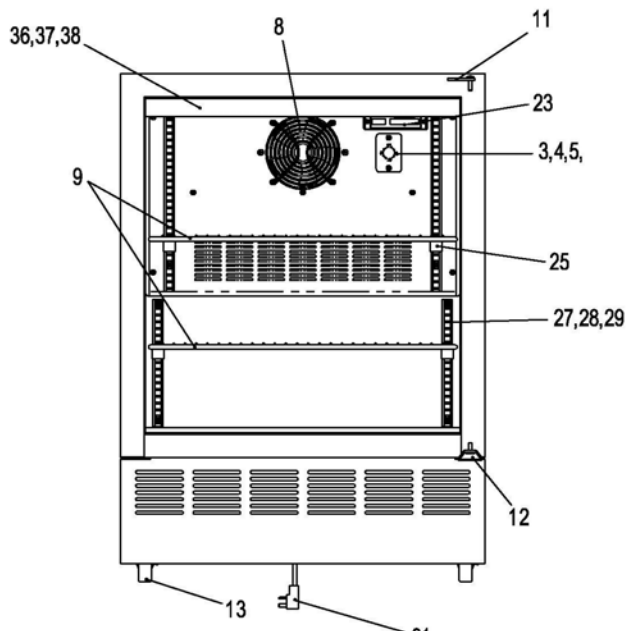
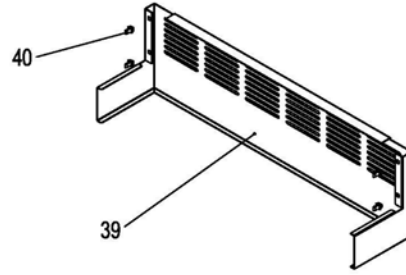

FRONT VIEW

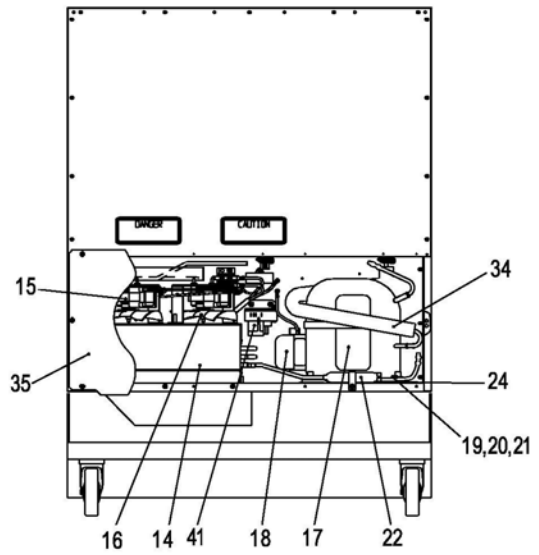

REAR VIEW

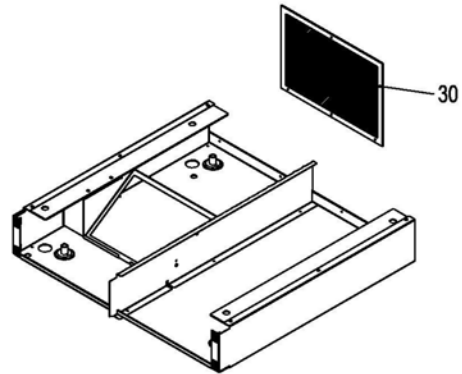
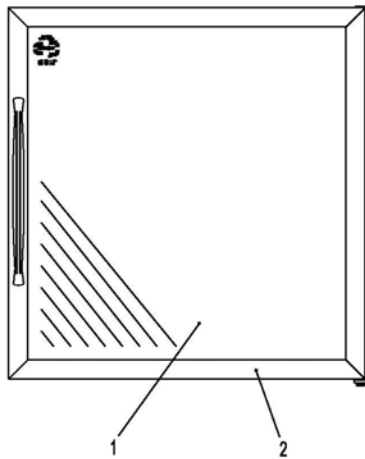

BASE GRILL AND FILTER

## REPLACEMENT PARTS LIST – MODEL **SKF27B/CQ**

ITEM NO.	PART DESCRIPTION	PART NO.
1	DOOR, GLASS 115V	29172
2	DOOR GASKET	25840
3	PLATE, TEMPERATURE CONTROL	20653
4	TEMPERATURE CONTROL	42575
5	KNOB, TEMPERATURE CONTROL	21487
6	FAN MOTOR, 115V/60HZ	21256
7	FAN BLADE, 5"	99196
8	FAN GUARD	41473
9	SHELVES	30657
11	HINGE, TOP	25702
12	HINGE, BOTTOM	25592
13	CASTER KIT, 3"	10314-69
14	CONDENSER COIL	43339
15	FAN MOTOR, 115V/60HZ	21251-2
16	FAN BLADE, 5"	99196
17	COMPRESSOR, 115V/60HZ	10343-59
18	ELECTRICAL KIT, 115V (RELAY, OVERLOAD, CAPACITOR)	10344-59
19	GROMMET, COMPRESSOR MOUNT	20481
20	HAIRPIN CLIP	98106
21	WASHER, COMPRESSOR MOUNT	22401
22	DRIER	23793
23	TEMPERATURE INDICATOR	30487
24	SCREW	97007
25	SHELF SUPPORT, WITH TANG	99531
26	SHELF SUPPORT	99530
27	PILASTER, 24"	29254
28	PILASTER, 14.5"	29255
29	PILASTER, 9.5"	29256
30	FILTER SCREEN	43499
31	POWER CORD, 115V	43263
32	EVAPORATOR / HEAT EXCHANGER ASSEMBLY	26581
33	EVAPORATOR COIL	63455
34	HEAT EXCHANGER	28083
35	REAR PANEL	29240
36	BALLAST	99571
37	STARTER	99184
38	LAMPHOLDER	21121
39	GRILL WITH LATCH AND STRIKE	30484
40	GRILL, LATCH AND STRIKE ONLY	29301
41	DEFROST TIMER, 115V	99291
42	DEFROST THERMOSTAT	33338
43	DEFROST HEATER, 115V	26072

WHEN ORDERING REPLACEMENT PARTS, PLEASE PROVIDE MODEL AND SERIAL NUMBERS

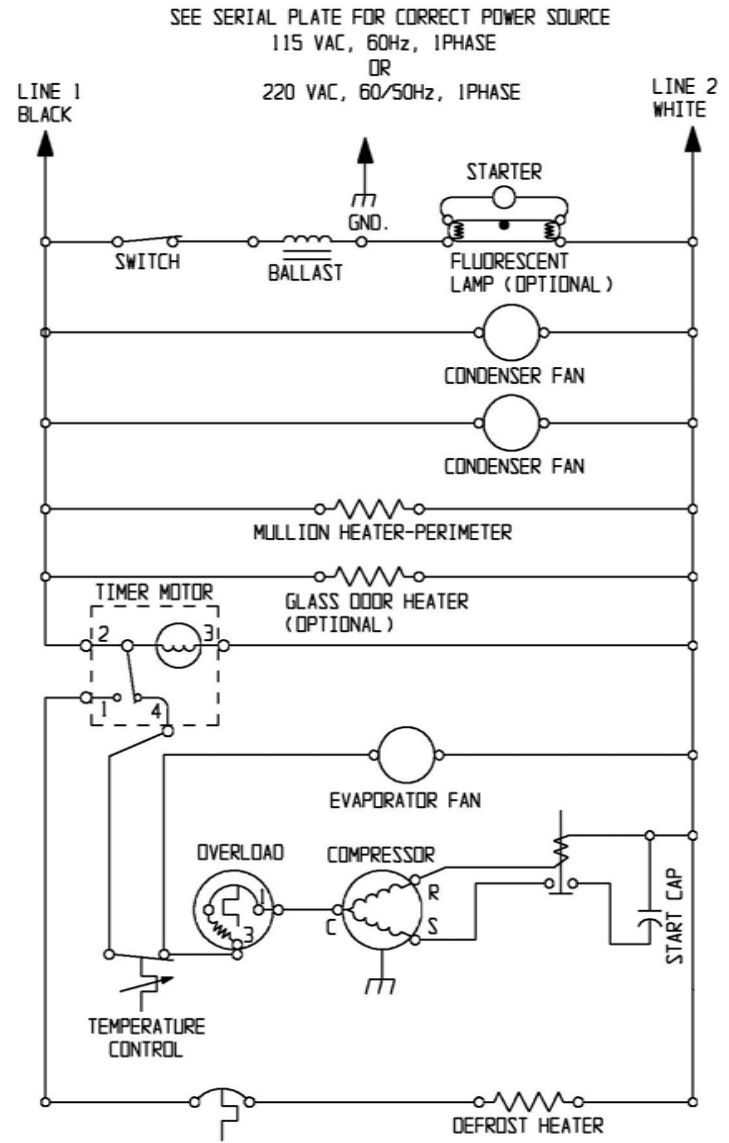
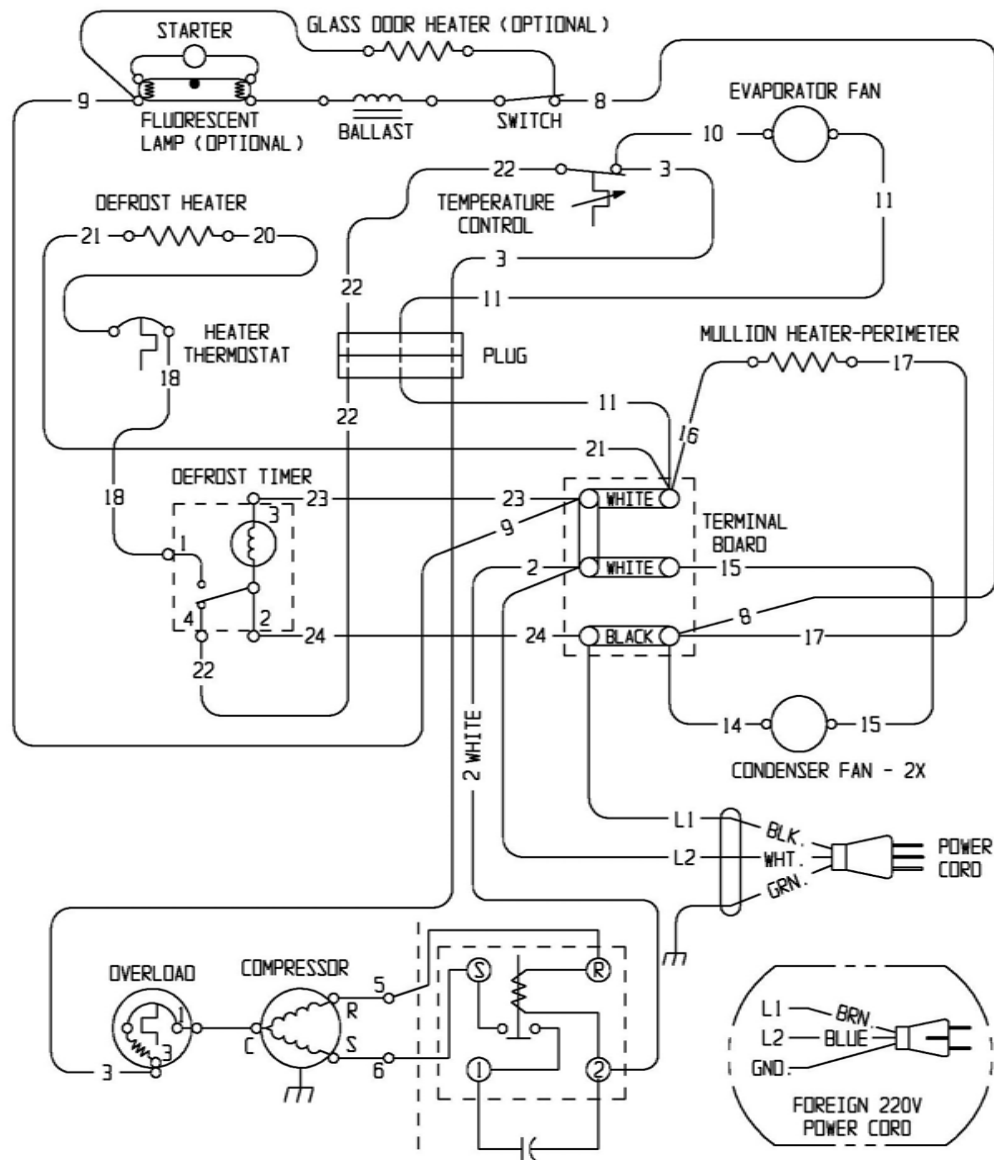

WIRING DIAGRAM  
 MODEL SKF27  
 SKF27D  
 SKF27BD