

This equipment chapter is to be inserted in the appropriate section of the *Equipment Manual*.

**Manufactured exclusively for
McDonald's®
By
Silver King Refrigeration, Inc
Minneapolis, MN 55441
800-328-3329
info@silverking.com**



TABLE OF CONTENTS

Warranty.....	2
Introduction	3
Safety	4
Operation.....	4
Parts Identification / Function and Exploded View.....	5
Parts Identification / Function and Exploded View.....	6
Cleaning and Refilling Procedures	7
Cleaning and Refilling Procedures	8
Troubleshooting Guide.....	9
Ordering Parts/Service.....	9
Wiring Diagram.....	10

Warranty

Silver King warrants to the original purchaser of Silver King refrigerated equipment that the equipment shall be free from defects in material and workmanship under normal use and service as outlined in the Technical Manual. This limited warranty shall apply for a period of two (2) years from the date of original purchase. The Compressor will carry an additional three (3) year warranty. All warranties are subject to specific limitations outlined below.

This limited warranty does not apply to repair or replacement required as a result of carelessness, neglect and/or abuse, including improper installation, incorrect voltage supply, tampering with or altering components and/or equipment or failure to perform proper maintenance. Equipment damaged in transit, by fire, flood or an act of God is not covered. This limited warranty does not include freight, handling, installation, labor (following the two (2) year labor warranty period) or other incidental or consequential costs including product and/or economic loss. This limited warranty is in lieu of all other warranties, express or implied, including those of merchantability, and is non-transferable.

Specific provisions of this limited warranty are as follows:

Two (2) Year Parts Warranty

Silver King warrants to the original purchaser of new Silver King equipment that such equipment and all parts thereof will be free of defects in material and workmanship, under normal use and service, for a period of two (2) years from the date of original purchase or 25 months from the date of shipment from the factory, whichever comes first, subject to all terms and conditions herein.

This warranty is limited to repairing or replacing any parts that, at Silver King's discretion, are deemed to be defective within the time period covered by this warranty. The warranty does not cover freight or handling charges incurred to replace such parts. Use of non-OEM parts may, at Silver King's discretion, void this warranty. If approved, warranty credit for non-OEM parts will be issued at the OEM cost.

Replacement parts sold separately are warranted for 90-days from date of purchase.

Five (5) Year Compressor Warranty

Silver King warrants to the original purchaser for a period of five (5) years from the date of original purchase or five (5) years and one (1) month from the date of shipment from the factory, whichever comes first, that it will replace the compressor with one of similar design and capacity, exclusive of delivery and installation charges, if it is found to Silver King's satisfaction to be inefficient or inoperative due to defects in material or factory workmanship. It is the owner's responsibility to return the serial plate of the defective compressor or at Silver King's option the complete compressor, to the factory. Failure to do so will void the warranty.

Two (2) Year Labor Warranty

Silver King warrants to the original purchaser for a period of two (2) years from the date of purchase or 25 months from the date of shipment from the factory, whichever comes first, a limited service labor warranty on Silver King refrigerated equipment subject to the following terms;

A factory issued Service Authorization Number must be obtained prior to work being performed under the labor warranty. Call your supplier or Silver King. Claims submitted without a Service Authorization Number will be paid at Silver King's discretion.

The labor warranty includes standard straight time labor charges in accordance with Silver King's Labor Warranty Guidelines and reasonable travel time, as determined by Silver King.

The warranty does not cover original installation, startup, normal adjustments or maintenance. Normal adjustments and maintenance include, but are not limited to; temperature control adjustments, temperature indicator calibrations, coil and filter cleaning, condensate drain cleaning.

A second service call for a related failure is not covered.

Use of refrigerants other than specified on the equipment serial plate voids the warranty.

All claims must include; model and serial number of equipment, date of purchase, date of failure, and a copy of the service invoice detailing the defect and service performed. No claim will be processed without this information. All claims must be filed within 60 days from date of service.

Introduction

The SKMCD1P Cream Dispenser is designed to hold and dispense bulk coffee cream. It will dispense three portion sizes – 1 cream packet, 2 cream packets, or 3 cream packets.

Setup

Legs

The dispenser is shipped without legs attached. To install them, carefully tilt the unit and thread the legs into the four corner holes on the bottom of the dispenser.

Drip Tray

The Drip Tray and Drip Tray Cover are installed as shown.

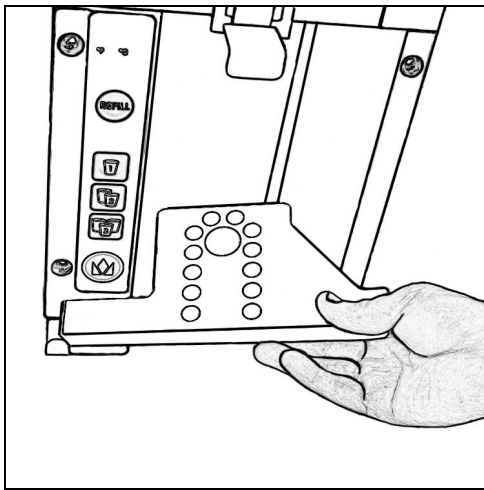

Location

When locating your cream dispenser, convenience and accessibility are important considerations, but the following factors must be observed:

- When placing the unit on a counter, the counter must be able to support a minimum of 100 pounds.
- When placed on a counter, the unit must be on the feet supplied. If the feet are removed the unit will not operate properly and the warranty will be void.
- There must be at least two inches of space above, on the sides and behind the unit and open in front.
- Correct serving height is important so that it can be operated properly.
- The unit must be level. The feet are adjustable to aid in leveling the unit.
- Avoid placing the unit next to an oven, heating element or hot air source which would affect the performance of the unit.

Electrical Connections

Be sure to check the data plate, located on the liner of the cabinet, for required voltage prior to connecting the unit to power. The specifications on the data plate supersede any future discussion.

The standard dispenser is equipped with a seven (7) foot power cord that requires a 115 Volt, 60 Cycle, 1 Phase properly grounded electrical receptacle protected with a 15 or 20 ampere fuse or breaker. The power cord comes with a 3 prong plug for grounding purposes. Any attempt to cut off the grounding spike or to connect to an ungrounded adapter plug will void the warranty, terminate the manufacturer's responsibility and could result in serious injury.

Safety

Risk of Electric Shock

- **Always be sure to unplug the power cord before servicing the dispenser or removing the back panel or front apron to avoid electric shock.**
- Dispenser must be plugged into a 3 prong plug for grounding. Cutting off the grounding spike on the power cord could result in electric shock to the operator during operation.
- Dispenser must be plugged into a 15 or 20 ampere fuse or breaker. Use of a larger fuse or breaker could result in damage to the dispenser and electric shock to the operator.

Moving and/or Hot Parts

- Be sure to unplug the power cord before servicing the dispenser or removing the back panel or front apron to avoid contact with moving and/or hot parts.
- Some parts may remain hot even after being unplugged. Use caution when servicing.

Back Injury

- Assistance should be utilized when moving this piece of equipment
- Be sure to lift with your legs and not your back when lifting the dispenser.

Operation

Initial Startup

After satisfying the installation requirements, the cream dispenser is ready to start. The unit will start when the power cord is connected to a live electrical receptacle. This can be verified by checking the indicator panel on the front of the unit. The indicator should display the current unit temperature. If the unit does not start when the power cord is plugged in, make sure that the switch on the back of the unit is in the 'on' position. Allow the unit to run a minimum of two hours before loading it with product. **It is completely normal for the exterior of the unit to feel warm while it is running.**

Indicator Panel

The Indicator Panel contains a digital LED display that reads the product temperature during normal operation. The three lower buttons on the Indicator Panel are for selecting portion sizes (small or large). The upper button is used to reset the computer whenever the cream is refilled. **This button must be pressed each time the cream is refilled. Press and hold the REFILL button for 3 seconds until the indicator flashes 00.**

Preparation for Use

Once the unit has achieved proper operating temperature, observe the procedures noted in the label on the door liner for loading cream into the cream dispenser. When removing an empty bag of cream, be sure to push the Valve Slide in fully before pulling the Dispensing Tube out of the valve. It may be easier to remove or install the Dispensing Tube in the valve by removing the Valve Insert first then removing or installing the Cream Container. The end of the tube may need to be cleaned daily with a clean cloth to prevent buildup which could affect the dispensing of product. **After loading the creamer, press and hold the REFILL button for 3 seconds until the indicator flashes 00.**

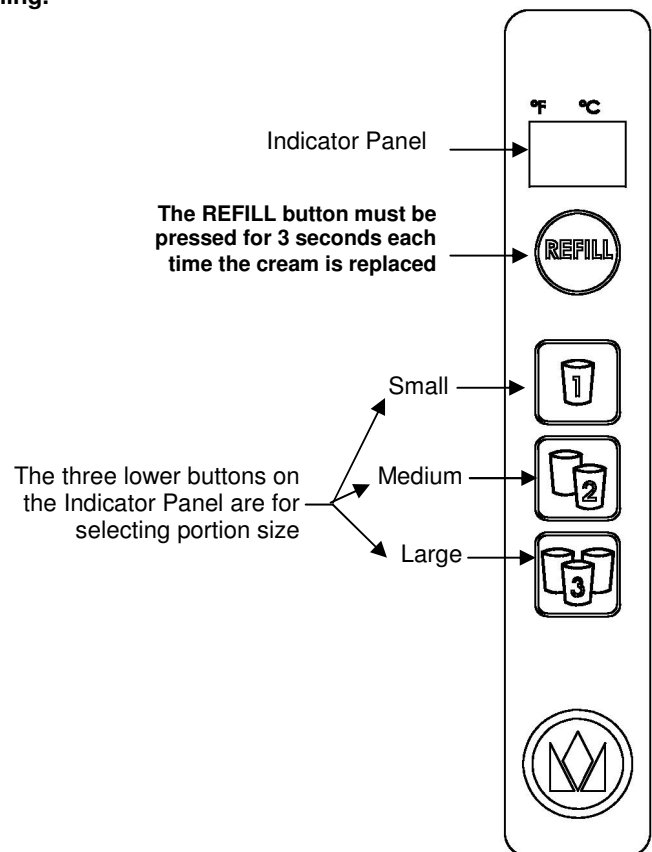

Parts Identification / Function and Exploded View

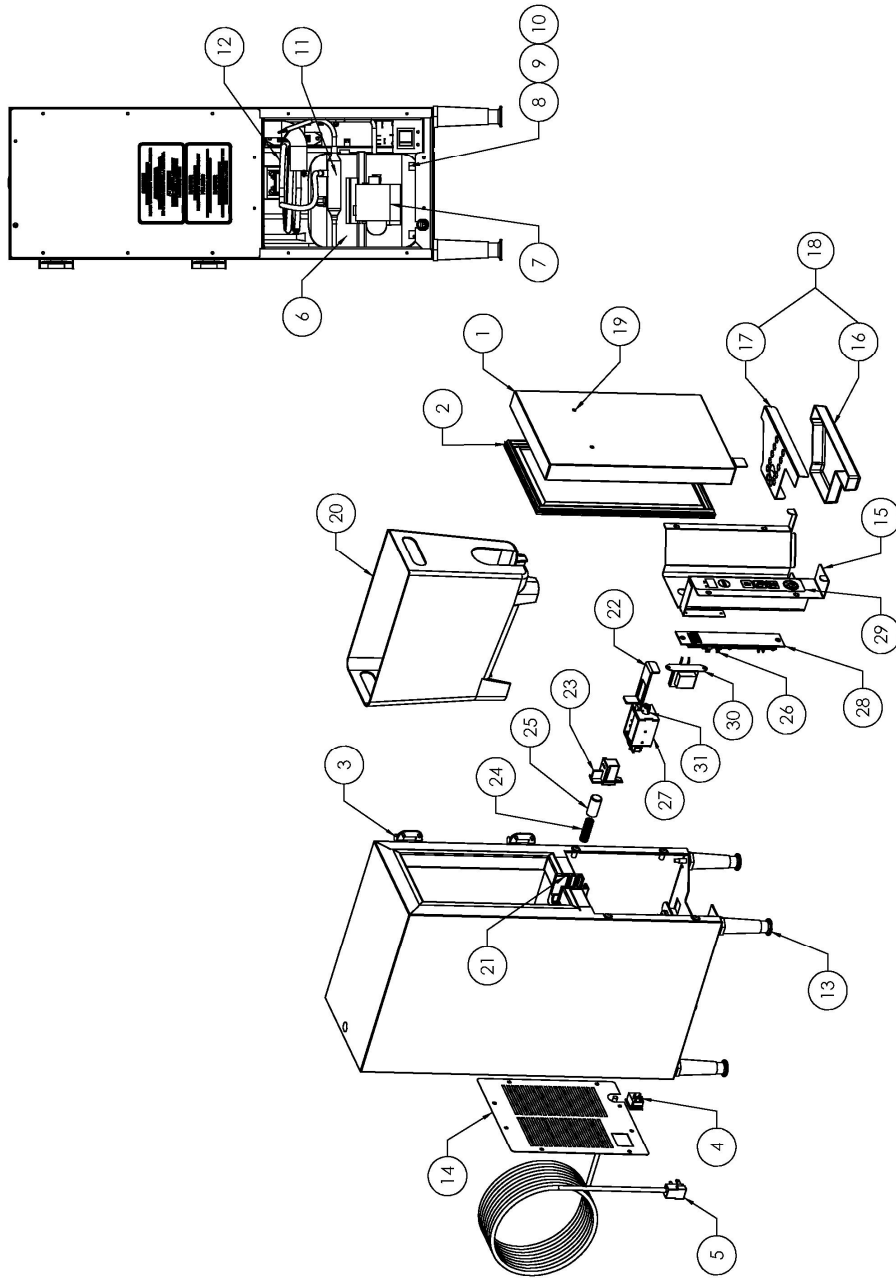

33985 REV C

Parts Identification / Function and Exploded View

ITEM NO.	PART DESCRIPTION	PART NUMBER
1	DOOR ASSEMBLY (LESS HINGES)	31106
2	DOOR GASKET	10310-61
3	HINGE	25226
4	SWITCH	26378
5	POWER CORD 115V	22099
6	COMPRESSOR KIT 115V	10343-51
7	ELECTRICALS KIT (RELAY AND OVERLOAD) 115V	10344-51
8	GROMMET, COMPRESSOR MOUNT	20481
9	HAIRPIN CLIP	98106
10	WASHER, COMPRESSOR MOUNT	22401
11	DRIER	22677
12	HEAT EXCHANGER	30876
13	LEG KIT 4"	10314-89
14	BACK PANEL	31117
15	APRON	33368
16	DRIP TRAY	31118
17	DRIP TRAY COVER	31119
18	KIT, DRIP TRAY AND COVER	33177
19	SCREW	22938
20	KIT, CONTAINER	31348
21	VALVE BODY	31942
22	VALVE SLIDE	33369
23	VALVE INSERT	31944
24	VALVE SPRING	27019
25	CAP SLEEVE	33726
26	THERMISTOR	26155
27	SOLENOID 115V	27696
28	ELECTRONIC BOARD (3-BUTTON) W/ THERMISTOR	32131
29	MEMBRANE SWITCH (3-BUTTON)	32034
30	ASSY TRANSFORMER 115V	26039
31	PLUNGER	34877

Cleaning and Refilling Procedures

Removing Valve Insert

To remove the valve insert once the beverage container is empty, simply press on the valve slide and remove the valve insert by pulling it straight up.

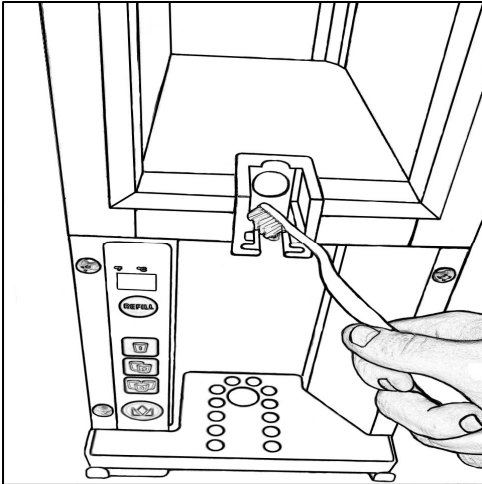
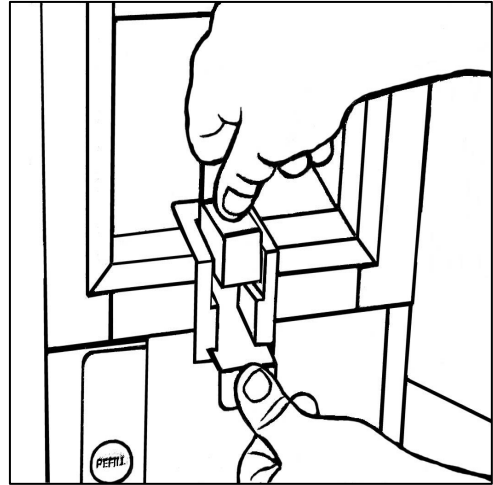

Cleaning

Once removed, the valve can be cleaned with a brush and warm soapy water or in a dishwasher. The valve area in the dispenser should also be cleaned with a brush and warm soapy water.

Insert New Bag into Container

Insert a new beverage bag into the container as shown. Lock the tube into place at the bottom of the container.

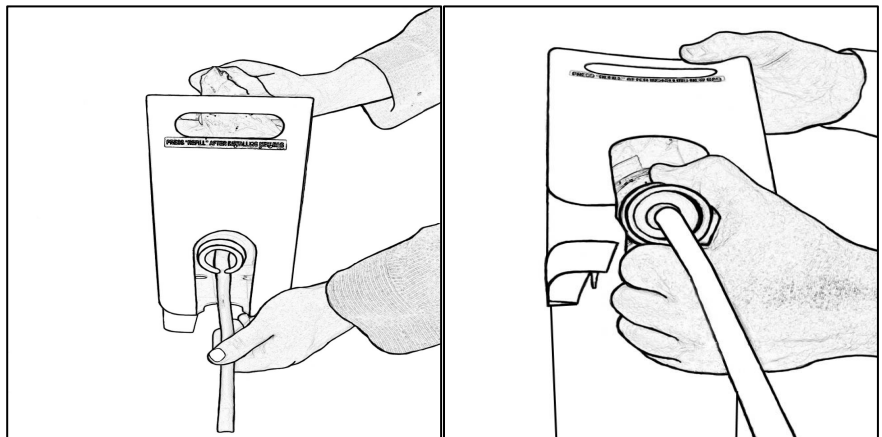

Cleaning and Refilling Procedures

Install Container and Bag

Place container inside cabinet and guide tube through valve area. Be sure the tube is straight and centered to avoid kinking, which could result in reduced product flow or leaking.

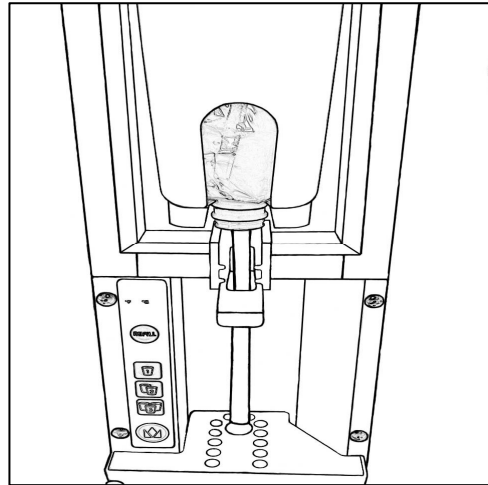
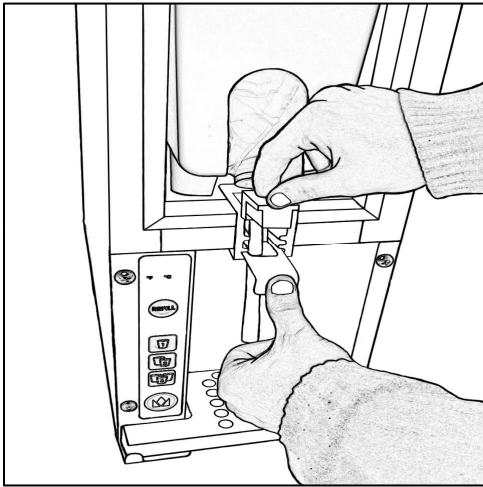

Install Valve Insert

Push and hold valve slide while inserting the valve insert from above.

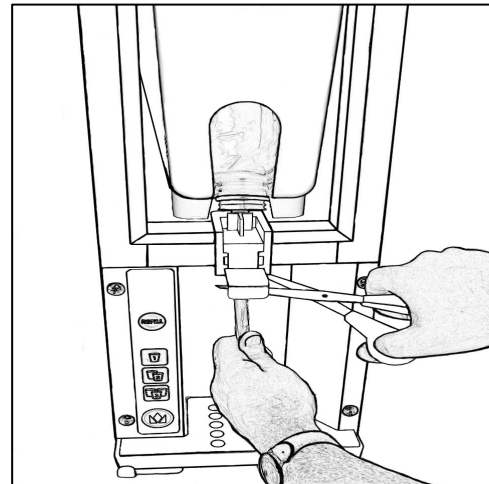

Cut Tube

Cut the tube one inch below the valve.

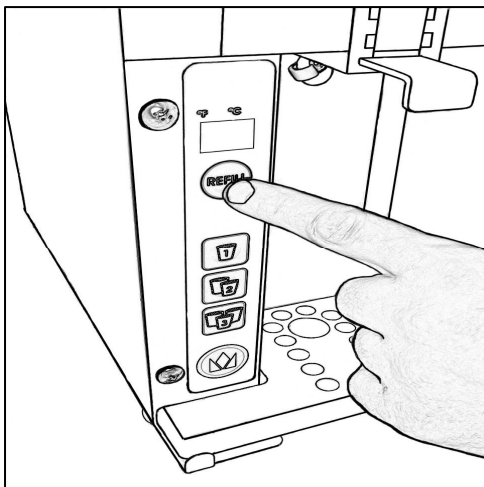

Press REFILL Button

Press and hold the REFILL button for 3 seconds (display 00) to alert the dispenser that a new beverage bag has been installed.

Troubleshooting Guide

Complaint	Cause	Solution
Compressor will not run	<ol style="list-style-type: none"> 1. No voltage at wall receptacle 2. Service cord pulled out of wall receptacle 3. Low voltage causing compressor to cycle on overload 4. Power switch is in "Off" position 5. Inoperative control 6. Compressor stuck 7. Compressor windings open 8. Compressor overload stuck open 9. Relay lead loose 10. Relay loose or inoperative 11. Power cord disconnected from dispenser 12. Faulty cabinet wiring 	<ol style="list-style-type: none"> 1. Check circuit breaker or fuse 2. Replace 3. Contact power company and confirm that voltage fluctuation does not exceed 10% plus or minus from the nominal rating 4. Turn switch on 5. Call service technician 6. Call service technician 7. Call service technician 8. Call service technician 9. Call service technician 10. Call service technician 11. Call service technician 12. Call service technician
Compressor runs but no refrigeration	<ol style="list-style-type: none"> 1. System out of refrigerant 2. Compressor not pumping 3. Restricted filter drier 4. Restricted capillary tube 5. Moisture in system 	<ol style="list-style-type: none"> 1. Call service technician 2. Call service technician 3. Call service technician 4. Call service technician 5. Call service technician
Compressor short cycles	<ol style="list-style-type: none"> 1. Erratic control thermostat 2. Faulty relay 3. Low voltage 4. Compressor draws excessive wattage 	<ol style="list-style-type: none"> 1. Call service technician 2. Call service technician 3. Contact power company and confirm that voltage fluctuation does not exceed 10% plus or minus from the nominal rating 4. Call service technician
Compressor runs too much or constantly	<ol style="list-style-type: none"> 1. Temperature too low 2. Erratic control 3. Abnormally high room temperature 4. Door or lid gaskets not sealing 5. System undercharged due to leaks 6. System undercharged from factory 7. System overcharged 8. System not clean 9. Restricted filter drier 10. Restricted capillary tube 	<ol style="list-style-type: none"> 1. Adjust temperature control 2. Call service technician 3. Reduce room temperature or relocate dispenser 4. Adjust or call service technician 5. Call service technician 6. Call service technician 7. Call service technician 8. Call service technician 9. Call service technician 10. Call service technician
Noisy	<ol style="list-style-type: none"> 1. Tubing vibrates 2. Internal compressor noise 3. Compressor vibrating on cabinet frame 	<ol style="list-style-type: none"> 1. Call service technician 2. Call service technician 3. Call service technician
Beverage leaking or not flowing	<ol style="list-style-type: none"> 1. Tube kinked 2. Valve stuck 	<ol style="list-style-type: none"> 1. Remove valve and pull tube straight through valve area 2. Clean valve and valve area or call for service

Ordering Parts/Service

Contact Silver King Refrigeration at 800-328-3329 for technical assistance.

Wiring Diagram

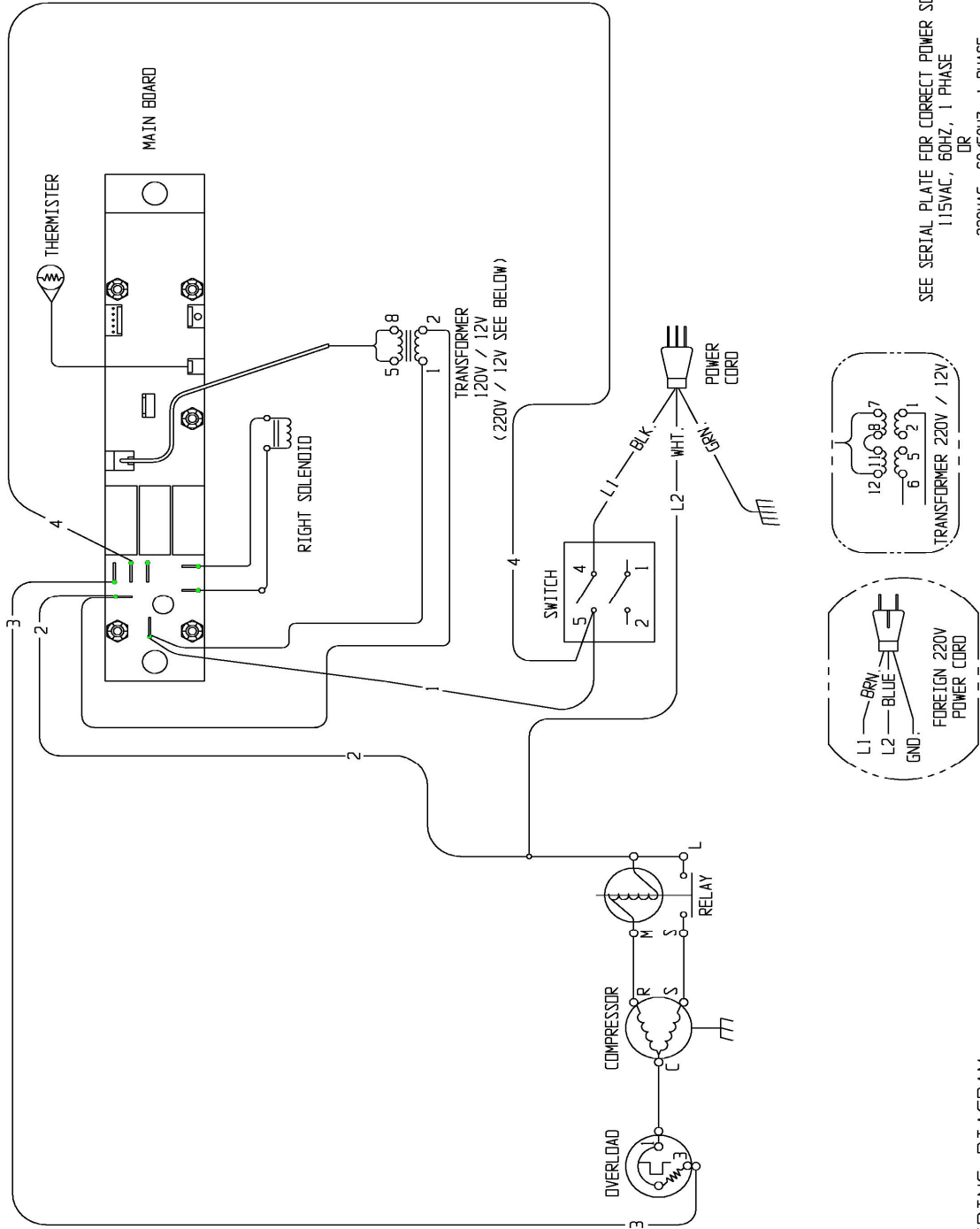

SEE SERIAL PLATE FOR CORRECT POWER SOURCE
 115VAC, 60HZ, 1 PHASE
 OR
 220VAC, 60/50HZ, 1 PHASE

WIRING DIAGRAM
 MODELS SKRM1P, SKRM2P, SKMCD1P, SKMCD1SP, SKBD110P, SKBD120P

25993 REV D