

Technical Manual and Replacement Parts List

Counter Top Prep Station



**MODEL SKPS3/C3
(W/ ELECTRONIC CONTROL)**

SILVER KING REFRIGERATION INC.

1600 Xenium Lane North, Minneapolis, MN 55441-3787
Phone (763) 923-2441

SILVER KING®

FORM 35997 REV C

Specifications Subject to Change Without Notice.



TECHNICAL MANUAL

SILVER KING MODEL SKPS3/C3 (W/ ELECTRONIC CONTROL)

Thank you for purchasing Silver King food service equipment. Our goal is to provide our customers with the most reliable equipment in the industry today. Please read this manual and the accompanying warranty information before operating your new Silver King unit. Be sure to complete and mail the warranty card within 10 days of purchase to validate your warranty.

INSPECT FOR DAMAGE AND UNCRATE

Upon delivery of your new Silver King unit, uncrate at once to inspect for possible freight damage following the instructions printed on the exterior of the container. Report any damages to the carrier responsible for transportation and promptly present a claim for any evidence of mishandling. If a claim is to be filed, be sure to save all packaging materials.

Electrical Connections

Be sure to check the data plate, located on the back of the cabinet, for required voltage prior to connecting the unit to power. The specifications on the data plate supersede any future discussion

The standard Model SKPS3 is equipped with an eight (8) foot power cord that requires a 15 Volt, 60 Cycle, 1 phase **properly grounded** electrical receptacle. The power cord comes with a 3 prong plug for grounding purposes. Any attempt to cut off the grounding spike or to connect to an ungrounded adapter plug will void the warranty, terminate the manufacturer's responsibility and could result in serious injury.

The electrical circuit must be protected with a 15 or 20 ampere fuse or breaker. The unit must be isolated on a circuit and not plugged into an extension cord.

OPERATION

Initial Start Up

After satisfying the installation requirements, the unit is ready to start. The unit will start when the power cord is connected to the required power source and the switch is in the "ON" position. Allow the unit to run with the cover closed for 30 minutes before loading it with **cold** product.

Loading

This unit is designed for (3) 1/9" size pans, 4 inches deep. The unit is designed to hold 33 to 41 degrees F. The covers should be closed when not in use to help maintain proper product temperatures. Food product should be lower than 41 degrees when loaded into the unit. This equipment is designed for holding, not storage of food prep items.

Defrost

This countertop prep station is a manual defrost unit. The unit should be defrosted whenever the bottom accumulates ice. To defrost the unit, turn the power switch to the "OFF" position, open the lid and remove the pans. After the frost has melted or come loose from the walls, wipe out the cabinet interior. Do not attempt to scrape or chisel off the frost as you could do irreparable damage to the unit.

MAINTENANCE

Preventative maintenance is minimal although these few steps are very important to continued trouble free operation and maximizing the life of your appliance.

Cleaning Instructions

The cabinet interior surface should be cleaned daily with a solution of warm water and mild soap, rinsed with clean water and wiped dry with a soft cloth. The cabinet exterior should be wiped clean with a damp cloth. Should a surface become discolored, do not attempt to clean with an abrasive cleanser or scouring pad. Use a soft cleanser to avoid scratching the surface. Always rinse with clean water and dry after using any cleaners. **DO NOT SUBMERGE UNIT IN WATER OR CLEANER**

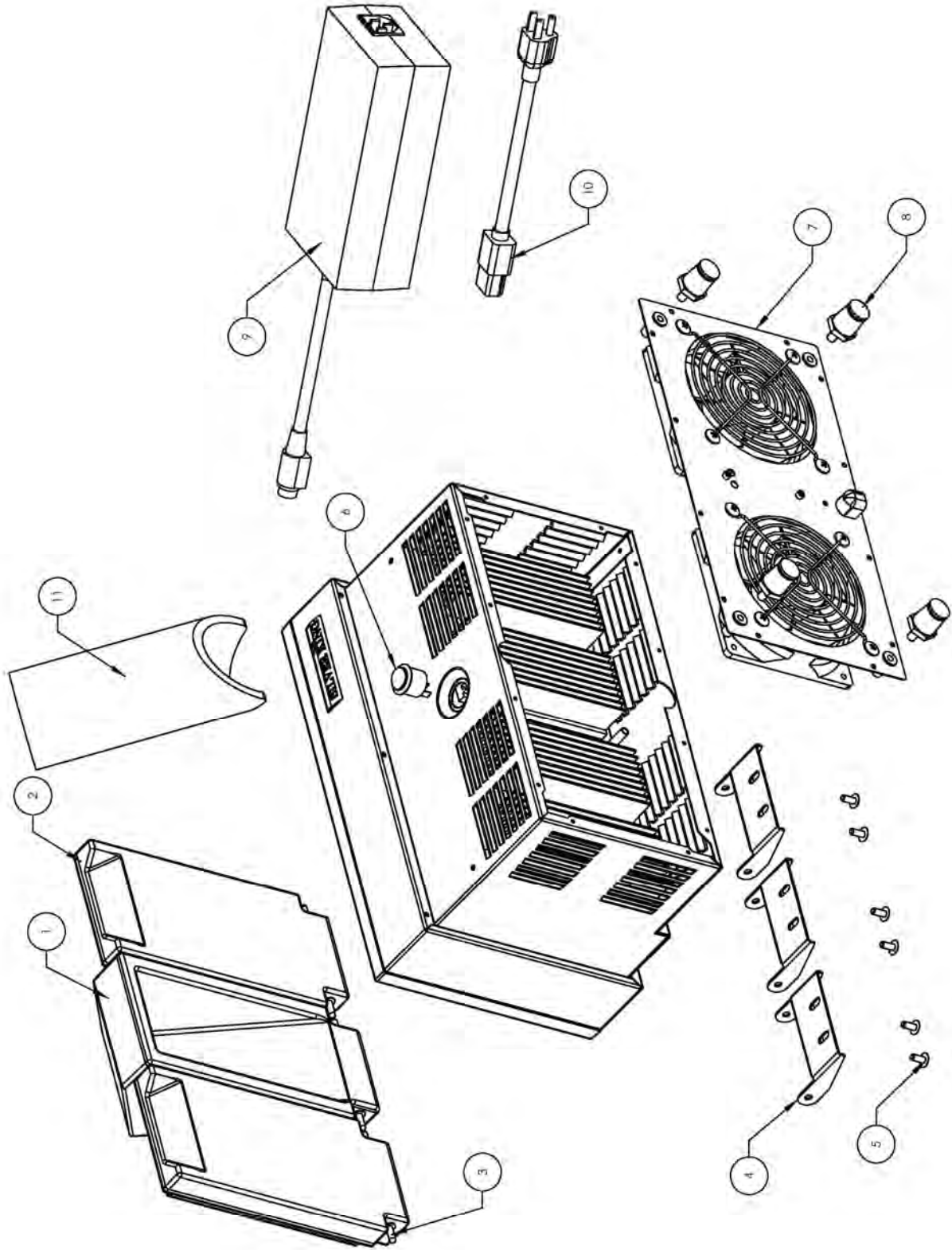

REPLACEMENT PARTS LIST - SKPS3/C3 W/ ELECTRONIC CONTROL

ITEM NO.	PART DESCRIPTION	PART NO.
1	LID (BOTTLE)	35211
2	LID (STANDARD)	35208
3	PIN GUIDE	21113
4	HINGE LID	35207
5	SCREW	23749
6	POWER SWITCH	35568
7	BASE ASSEMBLY	35998
8	LEG KIT	10314-95
9	POWER SUPPLY 12V 150W	35239
10	POWER CORD	35255
11	TUBE BOTTLE	35327

FORM 35996

WHEN ORDERING REPLACEMENT PARTS, PLEASE PROVIDE MODEL AND SERIAL NUMBERS

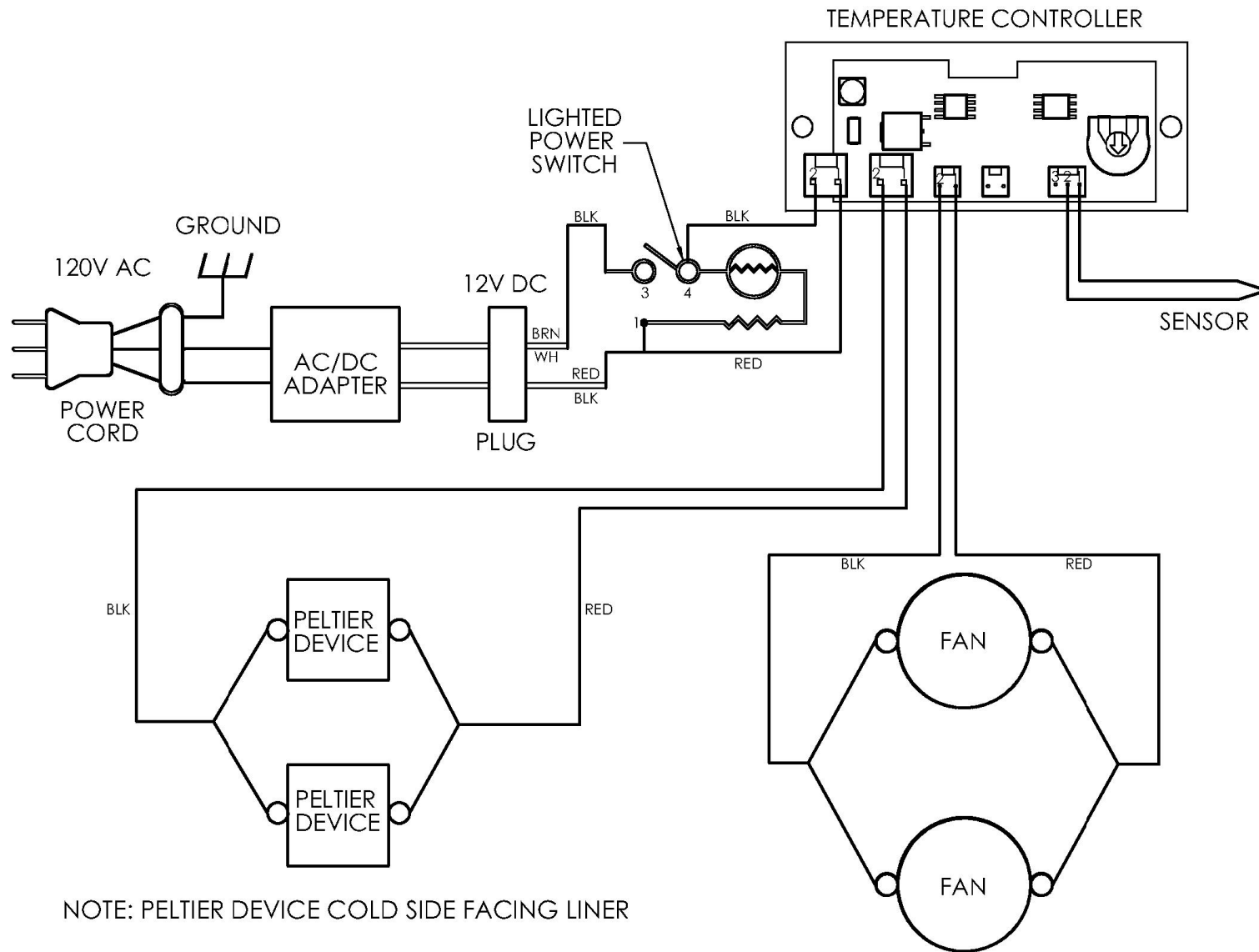

NOTE: PELTIER DEVICE COLD SIDE FACING LINER