

# V-MAX

---

Vendo V-Max

Manual

for

Coca-Cola®

Identified Equipment



The Vendo Company

7209 N. Ingram • Fresno, California 93650 • (559) 439-1770 • fax (559) 439-2083



# **V-MAX**

## **PARTS AND SERVICE MANUAL**

P/N: 1121848  
REV. D 8/2002



## V-MAX COCA-COLA TABLE OF CONTENTS

<b>SAFETY SECTION</b> .....	<b>Pages S-1 - S-18</b>
COMMITMENT TO SAFETY .....	Page S-2
SAFETY RULES .....	Page S-2
VENDOR INSTALLATION .....	Pages S-3 - S-6
ELECTRICAL HAZARDS.....	Pages S-7 - S-8
MECHANICAL HAZARDS .....	Page S-9
REFRIGERATION HAZARDS .....	Page S-10
TEMPERATURE HAZARDS.....	Page S-10
SUBSTITUTION AND MODIFICATIONS .....	Pages S-11 - S-12
CONSUMER SAFETY WARNING.....	Page S-13
GAS ISLAND VENDOR INSTALLATION PROTOCOL.....	Page S-14
MOUNTING TO PEDESTAL.....	Page S-15
PARTS AND SERVICE CENTERS .....	Pages S-16 - S-17
<b>GENERAL INFORMATION</b> .....	<b>Pages G-1 - G-12</b>
GENERAL INFORMATION.....	Page G-2
INITIAL SET UP .....	Pages G-3 - G-4
LABEL INSTALLATION .....	Page G-5
ALIGNMENT CHECKS.....	Page G-6
LOADING INSTRUCTIONS.....	Page G-7
VEND MECHANISM PARTS DESCRIPTION .....	Pages G-8 - G-9
VEND CYCLE .....	Pages G-10 - G-11
<b>9.2 PROGRAMMING SECTION</b> .....	<b>Pages CP-1 - CP-28</b>
GENERAL.....	Page CP-2
FOUR-BUTTON PROGRAMMING.....	Page CP-3
V-MAX CONTROLLER.....	Page CP-4
SET-UP AND CODE DESCRIPTION .....	Pages CP-5 - CP-23
9.2 WIRING DIAGRAM .....	Pages CP-24 - CP-27
<b>CABINET PARTS SECTION</b> .....	<b>Pages C-1 - C-18</b>
READING A PARTS LIST.....	Page C-2
V-MAX KIT LIST.....	Page C-3
HARDWARE LIST.....	Pages C-4 - C-5
INNER DOOR ASSEMBLY.....	Pages C-6 - C-7
CABINET ASSEMBLY .....	Pages C-8 - C-9
STACK ASSEMBLY.....	Pages C-10 - C-13
REFRIGERATION ASSEMBLY .....	Pages C-14 - C-15
AIR DAM ASSEMBLY.....	Pages C-16 - C-17
<b>V-MAX COCA-COLA PARTS SECTION</b> .....	<b>Pages CC-1 - CC-10</b>
MAIN DOOR .....	Pages CC-2 - CC-5
SELECTION PANEL.....	Pages CC-6 - CC-7
LOCK ASSEMBLY .....	Pages CC-8 - CC-9
<b>MARKETING VENDOR PARTS SECTION</b> .....	<b>Pages MDC-1 - MDC-14</b>
MAIN DOOR .....	Pages MDC-2 - MDC-5
SELECTION PANEL.....	Pages MDC-6 - MDC-7
LOCK ASSEMBLY .....	Pages MDC-8 - MDC-9
INNER DOOR ASSEMBLY.....	Pages MDC-10 - MDC-11
CABINET ASSEMBLY .....	Pages MDC-12 - MDC-13



## V-MAX COCA-COLA TABLE OF CONTENTS

<b>MINI V-MAX COCA-COLA PARTS SECTION .....</b>	<b>Page SCC-1 - SCC-10</b>
MAIN DOOR .....	Pages SCC-2 - SCC-5
SELECTION PANEL .....	Pages SCC-6 - SCC-7
LOCK ASSEMBLY .....	Pages SCC-8 - SCC-9
<b>V-MAX COCA-COLA ROBO DOOR.....</b>	<b>Page RDC-1 - RDC-8</b>
ROBO MAIN DOOR.....	Pages RDC-2 - RDC-5
ROBO SELECTION PANEL .....	Pages RDC-6 - RDC-7
<b>MAINTENANCE.....</b>	<b>Pages M-1 - M-10</b>
MAINTENANCE .....	Pages M-2 - M-3
REFRIGERATION OPERATION .....	Pages M-4 - M-6
REFRIGERATION PARTS DESCRIPTION.....	Pages M-7 - M-9
<b>TROUBLESHOOTING .....</b>	<b>Pages T-1 - T- 9</b>
VENDO WARRANTY .....	Pages T-2 - T-3
PARTS RETURN PROCEDURE.....	Page T-4
TROUBLESHOOTING GUIDE .....	Pages T-4 - T-8



# **V-MAX**

## **SAFETY SECTION**



## A COMMITMENT TO SAFETY

The Vendo Company is committed to safety in every aspect of our product design. Vendo is committed to alerting every user to the possible dangers involved in improper handling or maintenance of our equipment. The servicing of any electrical or mechanical device involves **potential hazards**, both to those servicing the equipment and to users of the equipment. These hazards can arise because of improper maintenance techniques. The purpose of this manual is to alert everyone servicing Vendo equipment of potentially hazardous areas, and to provide **basic safety guidelines** for proper maintenance.

This manual contains various **warnings** that should be carefully read to minimize the risk of personal injury to service personnel. This manual also contains service information to insure that proper methods are followed to avoid damaging the vendor or making it unsafe. It is also important to understand these **warnings** are not exhaustive. Vendo could not possibly know, evaluate, or advise of all of the conceivable ways in which service might be done. Nor can Vendo predict all of the possible hazardous results. The safety precautions outlined in this manual provide the basis for an effective safety program. Use these precautions, along with the service manual, when installing or servicing the vendor.

We strongly recommend a similar commitment to safety by every servicing organization. **Only properly-trained personnel should have access to the interior of the machine.** This will minimize the potential hazards that are inherent in electrical and mechanical devices. Vendo has no control over the machine once it leaves the premises. It is the owner or lessor's responsibility to maintain the vendor in a safe condition. See Section I of this manual for proper installation procedures and refer to the appropriate service manual for recommended maintenance procedures. If you have any questions, please contact the Technical Services Department of the Vendo office nearest you.

## SAFETY RULES

- Read the Safety Manual before installation or service.
- Test for proper grounding before installing to reduce the risk of electrical shock and fire.
- Turn off power switch or disconnect power cord from wall outlet before servicing or clearing product jams. The vending mechanism can trap and pinch hands.
- Use only fully-trained service technicians for Power-On servicing.
- Remove any product prior to moving a vendor.
- Use adequate equipment when moving a vendor.
- Always wear eye protection, and protect your hands, face, and body when working near the refrigeration system.
- Use only authorized replacement parts.
- Be aware of inherent dangers in rocking or tipping a vending machine.
- Always turn power off before plugging or unplugging vendor to wall outlet.



## SECTION I: VENDOR INSTALLATION

- A. Vendors are large, bulky machines of significant size and weight. Improper handling can result in injury. When moving a vendor, carefully plan the route to be taken and the people and equipment required to accomplish the task safely.
- B. Remove all tape, shipping sealant, and Styrofoam from the vendor. Loosen any shipping devices used to secure interior parts during shipping. Remove the wooden shipping base attached to the vendor base by the vendor leveling screws. Make certain the leveling screws are in place and functional.
- C. Position the vendor three to four inches (7.6 cm to 10.2 cm) from a well-constructed wall (of a building or otherwise) on a flat, smooth surface.

**IMPORTANT:** *The vendor requires three inches (7.6 cm) of air space from the wall to ensure proper air circulation to cool the refrigeration unit.*

- D. Adjust the leveling screws to compensate for any irregularities on the floor surface. Ideally, no adjustment will be necessary and the leveling legs will be flush with the bottom of the vendor. A spirit level is a useful aid to level the vendor. When the vendor is properly leveled the outer door, when opened, will remain stationary. Vendors must be level to ensure proper operation and to maintain stability characteristics. Do not add legs to the vendor.
- E. Check the manufacturer's nameplate on the left or right side of the vendor's outer door to verify the main power supply requirements of the vendor. Be sure the main power supply matches the requirements of the vendor. To ensure safe operation, plug the vendor only into a properly grounded outlet.  
**DO NOT USE EXTENSION CORDS.**
- F. Recommended voltage specs = volts required + amps of circuit.
- G. Dedicated 15A service required for 1 machine.

**NOTE:** Any power supply variance more than  $\pm 10\%$  may cause the vendor to malfunction.

- \* Power outlets must be properly **grounded**.
- \* Power outlets must be properly **polarized**, where applicable.

Test the outlets using the following information.  
(Refer to Figure 1 on Page S-4.)

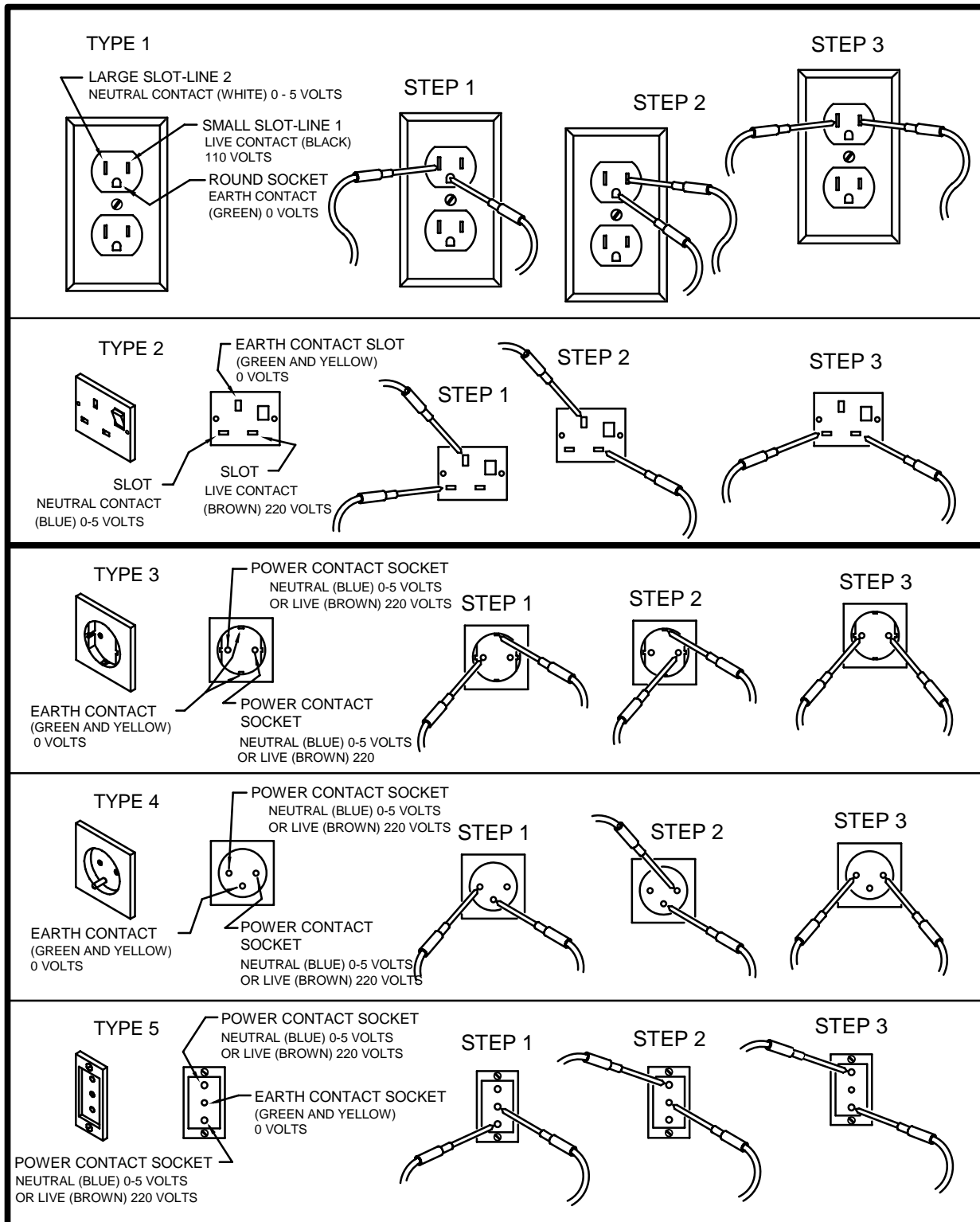

FIGURE 1 CHECKING FOR PROPER GROUNDING AND POLARIZATION



## SECTION I: VENDOR INSTALLATION (CONTINUED)

**For Type 1 and Type 2 outlets, test for Grounding and Polarization as follows:**

1. With a test device (volt meter or test light), connect one probe to the receptacle's neutral contact and the other to the live contact. The test device should show a reaction.
2. Connect one probe to the receptacle's earth contact and the other to the live contact. The test device should show a reaction.

**For Type 3 through Type 5 outlets, test for Grounding as follows:**

1. With a test device (volt meter or test light), determine which of the receptacle's power contacts is the live contact.
  - A. Connect one probe to the receptacle's earth contact.
  - B. Connect the second probe to the left (or upper) power contact. If a reaction occurs, this is the live power contact. If a reaction does not occur, move the second probe to the right (or lower) contact. A reaction should occur, indicating that this is the live power contact.
2. Connect one probe to the receptacle's live power contact (as determined in step 1). Connect the second probe to the other power contact (neutral). The test device should show a reaction.

**IF THE ABOVE CONDITIONS ARE NOT MET FOR THE GIVEN OUTLET TYPE, CONTACT A LICENSED ELECTRICIAN AND HAVE THE NECESSARY CORRECTIONS MADE.**



## SECTION I: VENDOR INSTALLATION (CONTINUED)

### H. Door Support (Figure 2)

The door support is to ensure that the outer door closes squarely to the cabinet. Raising the door can also ensure proper alignment of the door latch.

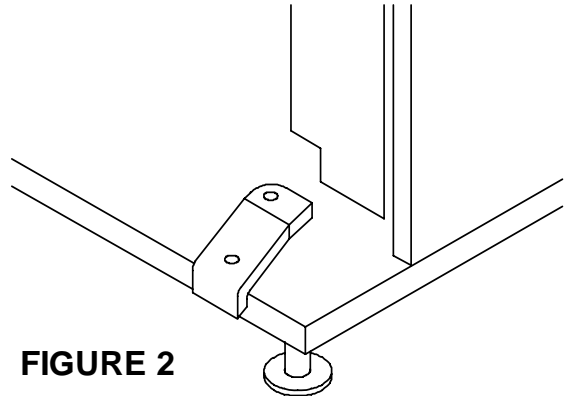
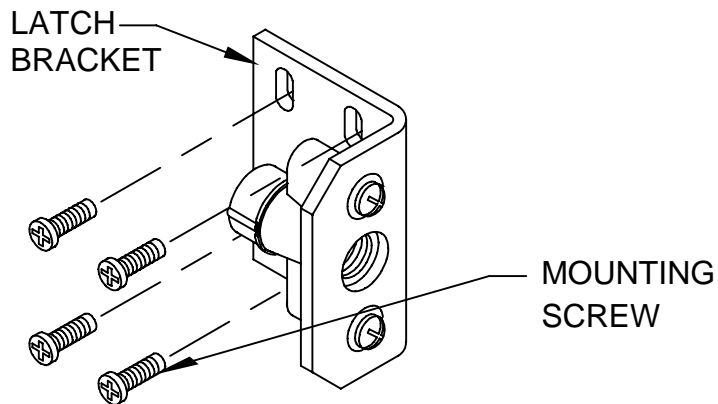

FIGURE 2

### I. Door Latch Alignment (Figure 3)

After any door adjustment, the floating quicker lock assembly should align itself automatically. The latch assembly is adjustable. To adjust, loosen the latch bracket mounting screws, raise or lower the latch assembly into position, then tighten the mounting screws.



**DO NOT INSERT OBJECTS INTO LOCK CAVITY.**

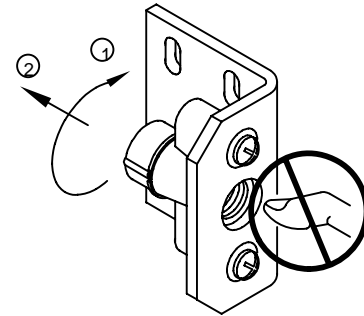

**TO FREE OBJECTS, REMOVE LOCK CAP AS SHOWN**

FIGURE 3

**WARNING:**  
**KEEP FINGERS AND OTHER OBJECTS OUT OF LOCK CAVITY**

**NOTE:** Refer to the appropriate parts and service manual for detailed instructions, operating principles, and recommended maintenance intervals and procedures.



## SECTION II: ELECTRICAL HAZARDS

### GENERAL

Vendo vending machines are provided with the appropriate power supply setting for your area. Some models are equipped with step-down transformers, as required. This enables the vending machine to operate on different main voltages. Refer to Section I. E. for information to determine the main power requirements. Refer to the appropriate service manual for details of step-down transformer operations.

The power sources just mentioned are standard for both household and commercial lighting and appliances. However, careless or improper handling of electrical circuits can result in injury or death. Anyone installing, repairing, loading, opening, or otherwise servicing a vending machine should be alerted to this point. Apply all of the normal precautions observed in handling electrical circuits, such as:

- Refrigeration servicing to be performed by qualified personnel only.
- Unplug the vendor or move power switch to off position before servicing or clearing product jams.
- Replace electrical cords if there is any evidence of fraying or other damage.
- Keep all protective covers and ground wires in place.
- Plug equipment into outlets that are properly grounded and polarized (where applicable), and protected with fuses or circuit breakers.
- All electrical connections must be dry and free of moisture before applying power.

### A. Grounding Systems

Vendo vending machines are provided with the appropriate service cord for the power supply in your area. The service cord will connect to the matching electrical outlet. Always ensure that the outlet to be used is properly grounded before plugging in the vendor. (See pages S-3 through S-5.)

**WARNING:**  
**ALWAYS TEST TO VERIFY PROPER GROUNDING PRIOR TO  
INSTALLATION TO REDUCE THE RISK OF ELECTRICAL  
SHOCK AND FIRE**

The electrical grounding system also includes the bonding of all metal components within the vendor. This involves a system of bonding wires identified by green or green and yellow marking. The system uses serrated head screws, lock washers, and star washers to ensure the electrical connection between parts. Maintenance of vending equipment may involve disassembly. Include the above items when reassembling, even if the vending machine may appear to function normally without them. Omitting any of these items can compromise a link in the grounding system. See the appropriate service manual or kit instructions for components and assembly instructions.



## SECTION II: ELECTRICAL HAZARDS (CONTINUED)

### B. Servicing with “Power Off”

For maximum safety, unplug the service cord from the wall outlet before opening the vendor door. This will remove power from the equipment and avoid electrical and mechanical hazards. Service personnel should remain aware of possible hazards from hot components even though electrical power is off. See the appropriate sections of this manual for further information.

### C. Servicing with “Power On”

Some service situations may require access with the power on. Power on servicing should be performed **only by fully-qualified service technicians**. Particular caution is required in servicing assemblies that combine electrical power and mechanical movement. Sudden movement (to escape mechanical action) can result in contact with live circuits and vice versa. It is therefore doubly important to maintain maximum clearances from both moving parts and live circuits when servicing.

**WARNING:**  
**“POWER-ON” SERVICING SHOULD BE ACCOMPLISHED ONLY BY  
FULLY-TRAINED PERSONNEL. SUCH SERVICE BY UNQUALIFIED  
INDIVIDUALS CAN BE DANGEROUS.**

Power to lighting and refrigeration system is shut off automatically by the electronic controller when the outer door is opened. **Applies to V-Max only.**

**NOTE:** For power-on servicing of the vendor’s lighting system, turn lighting power on by accessing the “LIT” test function of the electronic controller (see programming on inner door). **Applies to V-Max only.**

For power-on servicing of the vendor’s refrigeration system, turn refrigeration power on by accessing the “CNPR” test function of the electronic controller (see programming on inner door). **Applies to V-Max only.**



### SECTION III: MECHANICAL HAZARDS

#### A. Servicing of Moving Parts and Assemblies

When servicing assemblies involving moving parts, **use extreme caution!!** Keep fingers, hands, loose clothing, hair, tools, or any foreign material clear of entrapment.

As noted before under the electrical hazards section, Power On servicing should **only** be performed by qualified personnel. Refer to and heed the warnings noted in the electrical hazards section. These warnings refer to the potential hazards associated with electrical power and moving parts. Always maintain maximum clearances from electrical and moving parts.

Always install protective covers and guards when reassembling equipment.

**WARNING:**  
**THIS VENDING MACHINE INCLUDES MECHANICAL EQUIPMENT WHICH CAN BE HAZARDOUS IF IMPROPERLY HANDLED OR SERVICED. USE CAUTION AND CONSULT THE VENDO SAFETY MANUAL AND THE VENDO SERVICE MANUAL FOR ADDITIONAL SAFETY INFORMATION.**

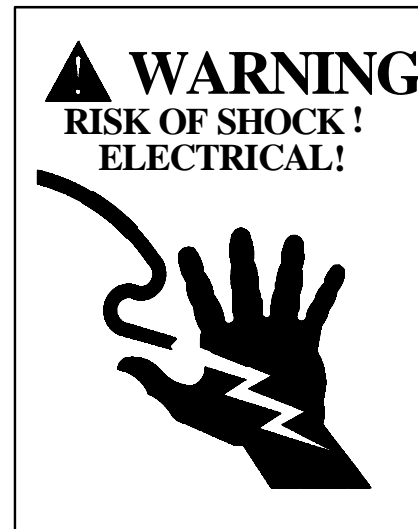



## SECTION IV: REFRIGERATION HAZARDS

### GENERAL

Refrigeration systems involve both electrical power and mechanical action. These systems may present any of the potential dangers shown in the sections on electrical and mechanical hazards contained in this manual. See Sections II and III for further information.

#### A. **Compressed Refrigerant**

Refrigeration systems involve the compression and evaporation of gases. The pressures contained represent a potential hazard if suddenly released in confined areas. Caution is required when performing maintenance tests or repairs. All testing of sealed refrigeration systems must be done by trained personnel who are familiar with the systems and pressures involved.

#### B. **Physical Protection**

The accidental release of refrigerant gases can result in physical injuries. Always wear protective glasses and protect your hands, face, and body when working near the refrigeration system.

**WARNING:**  
**ALWAYS WEAR EYE PROTECTION AND PROTECT YOUR HANDS, FACE, AND BODY WHEN WORKING NEAR THE REFRIGERATION SYSTEM.**

## SECTION V: TEMPERATURE HAZARDS

### GENERAL

Maintenance personnel should be alerted to the potential hazards from hot metal surfaces. High temperatures may be present throughout the refrigeration system even though electrical power has been removed.



## SECTION VI: SUBSTITUTIONS AND MODIFICATIONS

### GENERAL

Unauthorized changes or the substitution of unauthorized parts can compromise the equipment designs. This can result in unsafe conditions for either the service personnel or the equipment users. Always refer to the appropriate parts and service manual for replacement parts and maintenance instructions. If questions arise, contact the Technical Services Department of the Vendo office in your area.

When servicing the vending machine, always reassemble all components to their original location and position. Maintain the correct routing for tubing, electrical wiring, etc. Replace all clamps, brackets, and guides to their original locations. Replace all tubing, sleeving, insulating material, and protective covers to their original condition.

**WARNING:**  
**VENDO EQUIPMENT HAS BEEN PROVIDED WITH APPROPRIATE PROTECTIVE DEVICES TO PROTECT AGAINST THE POSSIBILITY OF OVERHEATING AND FIRE AS A RESULT OF EQUIPMENT OR COMPONENT FAILURES. SUBSTITUTION, MODIFICATION, OR BYPASSING OF SUCH PROTECTIVE DEVICES CAN CREATE DANGEROUS CONDITIONS. PROTECTIVE CIRCUITS SHOULD NEVER BE BYPASSED, AND FAILED PROTECTIVE DEVICES MUST BE REPLACED ONLY WITH FACTORY-AUTHORIZED PARTS.**

#### A. **Service Cord Replacement**

Vendo vending machines are furnished with unique power supply cords. If replacement becomes necessary, consult the appropriate parts and service manual and order the correct replacement cord for the model of vending machine in question. Do not use substitute replacement cords. Only authorized service personnel with appropriate training should replace the vending machine service cord. If a question should arise concerning which service cord to order, contact the Technical Services Department of the Vendo office in your area.



**SECTION VI: SUBSTITUTIONS AND MODIFICATIONS (CONTINUED)**

**WARNING:**  
**THIS APPLIANCE MUST BE EARTHED.**  
**IMPORTANT!**

The wires in the main leads are colored in accordance with the following code:

<b>110v/120v</b>	<b>220v/240v</b>	
<b>Green</b>	<b>Green and Yellow .....</b>	<b>Earth</b>
<b>White</b>	<b>Blue.....</b>	<b>Neutral</b>
<b>Black</b>	<b>Brown .....</b>	<b>Live</b>



**SECTION VII: CONSUMER**

**SAFETY WARNING**







**WARNING:  
VENDOR CAN BE OVERTURNED IF SUFFICIENT FORCE IS APPLIED, AND MAY RESULT IN SERIOUS INJURY OR DEATH.**

**GENERAL**

There have been incidents, including fatalities, when vending machines have been vandalized by being pulled over in an attempt to obtain free product or money.

To warn of the danger involved in tipping, shaking, or rocking the vending machine, a decal has been designed to be affixed to vending machines. (One such decal is supplied with the vending machine.) Vendo will supply sufficient decals to be placed on all machines, on request. If you have any questions, contact the Technical Services Department of the Vendo office in your area.

**THE FOLLOWING DECAL SHOULD BE PLACED IN A POSITION ON THE VENDOR CONTROL PANEL AT EYE LEVEL.**

 <p><b>WARNING</b></p>  <p>Never rock or tilt. Machine can fall over and cause serious injury or death. Vending machine will not dispense free product.</p> <p>389611A</p>	 <p><b>MISE EN GARDE</b></p>  <p>Ne jamais secouer ou incliner. Le distributeur peut se renverser et causer des blessures graves ou la mort. Cette machine ne distribue pas de produits gratuitement.</p> <p>389611-1A</p>	 <p><b>AVISO</b></p>  <p>Nunca voltie o incline esta maquina. Puede caer sobre usted y causarle heridas graves o matarle. Esta Vendomatica no provee producto gratis.</p> <p>389611-2A</p>
---	---	---

**ENGLISH**

**FRENCH**

**SPANISH**



## GAS ISLAND VENDOR INSTALLATION PROTOCOL

Vendo Gas Island Vending Machines have been evaluated by UL (Underwriters Laboratories Inc.®) for placement at service stations which the NFPA (National Fire Protection Association) considers a hazardous location. These vendors must be correctly installed and inspected per the following protocol before they are put into service.

- A. Vendor is to be installed in accordance with the National Electrical Code, NFPA 70, Article 514 - Gasoline Dispensing and Service Stations, NFPA 30A - Automotive and Marine Service Station Code, and the Local Authority Having Jurisdiction.  
IMPORTANT - Compliance includes direct wiring of the vendor to the voltage source utilizing proper metal conduit and circuit protection.

- B. When installed on support base, the vendor can be installed in an 18-inch high Class I, Group D, Division 2 Hazardous Location. Additionally, the vendor must be installed at least 18 inches from any flammable liquid dispensing device.  
Vendor support base is to be attached to vendor as shown by view on page S-15. Vendor should be securely bolted in place using ½-inch nominal diameter hardware as a minimum.

- C. IMPORTANT: FOR ANY INSTALLATION REQUIRING LEVELING OF THE VENDOR, IT IS MANDATORY TO OBTAIN APPROVAL OF THE LOCAL AUTHORITY HAVING JURISDICTION. THERE ARE **NO EXCEPTIONS**.

To level more than 1/8 inch, it is suggested to follow these guidelines:

1. Shimming of one or more mounting points should be done with solid steel, minimum thickness of 1/8 inch. Solid aluminum is acceptable.
2. It is not acceptable to place shims under all (4) mounting points.
3. Shims should be a minimum of 2 ½ inch x 2 ½ inch square or 2 ½ inch diameter.
4. Shim should have a hole, (approximately ½ inch diameter), through the center in the same manner as the GIV pedestal foot.
5. Shim should be protected against corrosion by painting, plating, etc.
6. IMPORTANT: Hold down bolt should be a solid, continuous bolt.

It is MANDATORY that all installations requiring leveling be approved by the LOCAL AUTHORITY HAVING JURISDICTION.

- D. **Warning - Power tools with arcing and sparking parts, such as electric drills, should not be used in any hazardous locations during the installation of this vendor.**
- E. The dispensing area shall be in clear view of the attendant at all times, and placing or allowing any obstacle to come between the dispensing area and the attendant control area shall be prohibited.
- F. Upon completion of the installation, the Local Fire Marshall, or Authority Having Jurisdiction, must verify the installation complies with the codes shown in Item A. After authorization, the vendor may be placed into operation.



## MOUNTING TO PEDESTAL

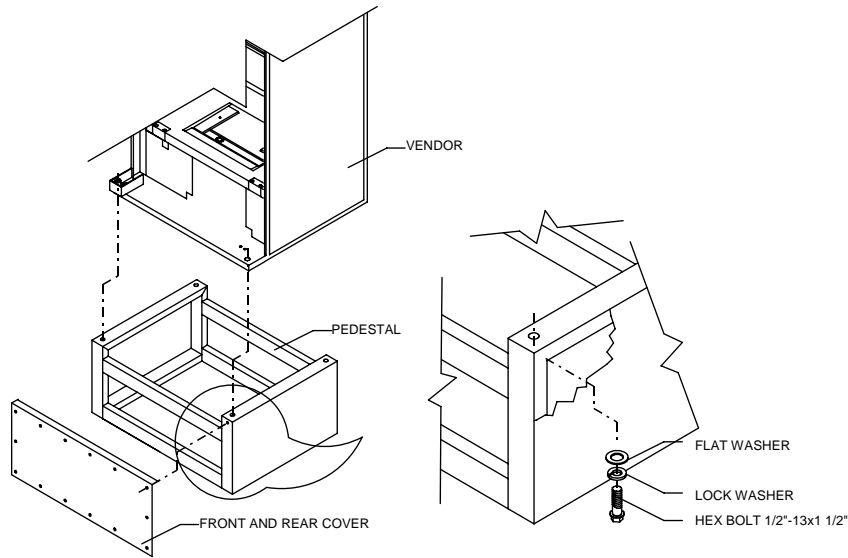

### **IMPORTANT - INSTALLATION REQUIREMENTS**

*Electrical equipment, such as vending machines, installed within a 20-ft. radius of a gasoline dispensing unit must meet safety specifications of the National Electrical Code, NFPA 70 - Article 514 - Gasoline Dispensing and Service Stations, NFPA 30A - Automobile and Marine Service Station Code, and the Local Authority Having Jurisdiction. Safety Specifications are:*

- The vending machine must be UL Listed for installation near gasoline dispensing equipment.
- The vending machine is UL Listed for use in an 18-inch high Class I, Group D, Division 2 Hazardous Location.
- Installation requires **ON-SITE** approval of Local Fire Marshall, or Authority Having Jurisdiction.
- The vending machine should be securely bolted in place using ½" nominal diameter hardware as a minimum. Use template provided on pedestal carton for mounting locations. If vendor requires leveling more than 1/8 inch, refer to Page S-14.
- The vending machine must be direct-wired to the voltage source utilizing proper metal conduit and circuit protection.

Note: There are unique safety and approval considerations required for placement of a vendor at the gasoline island which will require a non-standard vending machine. A standard vending machine located at or near the gasoline dispensing area will create unacceptable risks and will not meet safety agency requirements.



**PARTS, SALES, & SERVICE CENTERS OF VENDO/SANDEN COMPANY**

AREA	ADDRESS	PHONE NUMBERS
United States, Canada	The Vendo Company 7209 N. Ingram Fresno, CA 93650 U.S.A.	Tel: (559) 439-1770 Fax: (559) 439-2083
Japan	Sanden International Corporation 31-7 Taito 1-Chome Taito-ku Tokyo 110, Japan	Tel: (81) 3-3835-1321 Fax: (81) 3-3833-7096
Europe, Mid-East, Africa, Mid-Asia	Vendo GMBH Spangerstr. 22, P.O. Box 130940 40599 Dusseldorf Germany	Tel: (49) 211-74-039-0 Fax: (49) 211-7488541
Australia, New Zealand	Sanden International Pty. Ltd. 54 Allingham St., Condell Park N.S.W. 2200 Australia	Tel: 61-2-9791-0999 Fax: 61-2-9791-9029
Singapore, Hong Kong, Indonesia, Philippines, India	Sanden International (Singapore) Pte., Ltd. Sanden House, 25, Ang Mo Kio St. 65 Singapore 569062 The Republic of Singapore	Tel: 65-482-5500 Fax: 65-482-1697
Taiwan	Sanden International Taiwan Corp. No, 21-6, Sec 1 Tun Hwa S. Rd., Taipei, Taiwan Taiwan, ROC	Tel: 886-2-570-6106 Fax: 886-2-577-1959
Belgium	N.V. Vendo Benelux, S.A. Industrial Research Park N.O.H. 13 Font St. Landry 1120 Brussels Belgium	Tel: 32-2-268-2595 Fax: 32-2-268-2862
England	Vendhall, Ltd. Unit 17, The Basingstoke Enterprise Centre Westham Lane, Worting Rd, Basingstoke, Hants RG22, 6NQ Great Britain	Tel: 44-1256-479309 Fax: 44-1256-844469
Italy	Vendo Italy S.p.A. Casella Postale 9 1-15033 Casale Monferrato Italy	Tel: 39-142-335111 Fax: 39-142-5623-48
Spain	Vendo Iberia, S.A. C/ Sant Ferran No. 92 Poligono Industrial la Almeda, Sector P-1 08940 Cornellà, (Barcelona), Spain	Tel: 343-474-1555 Fax: 343-474-1842



**PARTS, SALES, & SERVICE CENTERS OF VENDO/SANDEN COMPANY  
FOR LATIN AMERICA**

AREA	ADDRESS	PHONE NUMBERS
Mexico	Vendo de Mexico Camino Real de Toluca No. 154 Col. Bellavista 01140 Mexico D.F. Mexico	Tel: (525) 515-9745 Fax: (525) 277-0111
Central America	The Vendo Company 7209 N. Ingram Fresno, CA 93650 U.S.A.	Tel: (559) 439-1770 Fax: (559) 439-2083
Chile	Pelp Internacional, S.A. 4560 El Rosal Huechuraba, Santiago, Chile	Tel: (562) 243-9710 Fax: (562) 740-0504
Brazil	Cimaq Industria e Comercio de Maq, Ltda. Estrada Uniao e Industria, 9.120 Itaipava 25730-730 Petropolis Rio de Janeiro, Brazil	Tel: (55242) 22-2666 Fax: (55242) 22-3244
South America	The Vendo Company 7209 N. Ingram Ave. Fresno, CA 93650 U.S.A.	Tel: (559) 439-1770 Fax: (559) 439-2083



## NOTES



# **V-MAX**

## **GENERAL INFORMATION**



## GENERAL INFORMATION

This manual contains programming, operation, and complete parts and electrical wiring diagrams.

The V-MAX controller is a microprocessor which will permit pricing per selection from 0.00 to 99.99. This machine also has space-to-sales programming.

### Specifications:

MODEL		V-MAX 576	V-MAX 540/720	V-MAX 630/840	V-MAX 512/680	V-MAX 603/800
SELECTIONS		7-8	9-10	9-10	9 or 13	9 or 13
<b>DIMENSIONS (HEIGHT X WIDTH X DEPTH)</b>						
CURVED DOOR		72" x 32 1/2" x 34 3/4"	72" x 39 1/2" x 35"	79" x 39 1/2" x 35"	Not Available	Not Available
FLAT DOOR		72" x 32 1/2" x 31 1/2"	72" x 39 1/2" x 32 1/2"	79" x 39 1/2" x 32 1/2"	Not Available	Not Available
MARKETING VENDOR		Not Available	Not Available	Not Available	72" x 39 1/2" x 34 3/4"	79" x 39 1/2" x 34 3/4"
ROBO DOOR		Not Available	72" x 39 1/2" x 32 1/2"	79" x 39 1/2" x 32 1/2"	Not Available	Not Available
SINGLE COLUMNS		8	10	10	10	10
CAPACITY PER COLUMN	12 oz. CAN***	72	72	84	51/68	60/80
	16 oz. GLASS	30	30	36	26	32
	20 oz. **	32	32	38	30	36
SHIPPING WEIGHT		640 lbs	685 lbs	750 lbs	758 lbs	818 lbs
OPERATION VOLTAGE		115v 60 Hz.	115v 60 Hz.	115v 60 Hz.	115v 60 Hz.	115v 60 Hz.
AMP. RATING		10	10	10	10	10
REFRIGERATION VOLTAGE		115v 60 Hz.	115v 60 Hz.	115v 60 Hz.	115v 60 Hz.	115v 60 Hz.

\*Dimensions and shipping weight will vary slightly due to manufacturing tolerances, shipping boards and whether or not coinage is installed.

\*\* 20 oz. PET capacity may vary based on the shape and size of the bottle.

\*\*\*12 oz. Can capacities are listed using a 4-deep set up.

## INITIAL SET-UP



## **A. UNPACKING**

Remove all plastic film, cardboard, and tape from the outside of the vendor. Loosen any shipping devices used to secure interior parts during shipment (backspacer, shims, or spacers).

To remove shipping boards from base, raise vendor on a well-stabilized lifting device. Remove the leveling bolt which holds the boards in place and remove the boards. Replace bolts to equal heights in the threaded holes.

Another method to remove shipping boards is to split the boards apart. Using a pinch bar or a heavy screwdriver and hammer, insert tool into the slots and force the board apart.

## **B. POSITIONING**

**IMPORTANT: PLACE THE VENDOR IN DESIRED LOCATION AT LEAST THREE TO FOUR INCHES (8 TO 10 CENTIMETERS) AWAY FROM ANY REAR OBSTRUCTION.** This is for proper air flow through the refrigeration compartment. The refrigeration system requires front to rear air circulation for proper operation.

## **C. POWER SUPPLY CONNECTION**

### **CAUTION: DO NOT USE AN EXTENSION CORD!**

The vendor's power requirements will vary depending upon the country it was purchased for. To verify the power requirements of the vendor, check the serial plate located on the hinged side of the outer door (see Figure 4 on page G-4). The power requirements are listed on the serial plate.

To insure safe operation of the vendor, the vendor's power supply must be a properly grounded and polarized outlet. Before plugging the vendor into the outlet, test the outlet to confirm it will meet the vendor's power requirements. If the power supply of the outlet is different from the power requirements of the vendor, a transformer may be necessary.

If the power requirements are not properly met, contact a licensed electrician and have the necessary correction made.

Should you require additional information, contact the Technical Services Department of the Vendo office in your area.

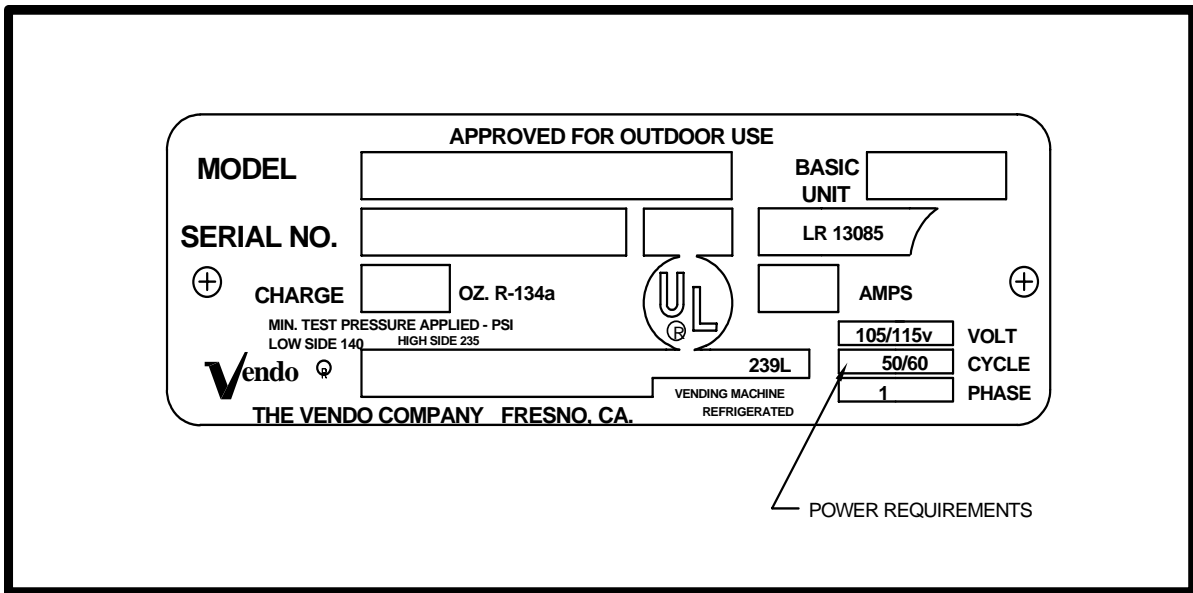

**FIGURE 4**

**NOTE:** The **Model** number of the vending machine is located on the top left hand corner of the serial plate. **Do Not use the “BASIC UNIT” number.** The **BASIC UNIT** number is the cabinet size, which is used on a number of different machines. A typical model number could read “540CCD00029”. The 540 is the model number, CCD represents the product line of the vendor and the remaining digits tell what options are included.

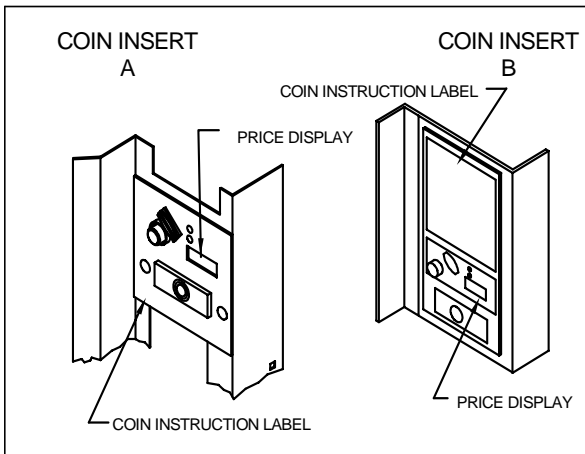

FIGURE 5

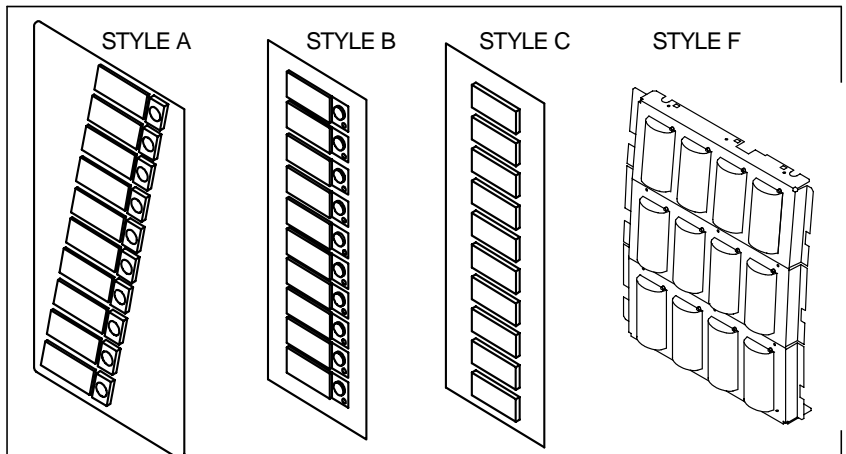

FIGURE 6

**LABEL INSTALLATION**

**COIN INSTRUCTION LABEL & PRICE LABEL APPLICATION:**

Apply labels to a clean and dry surface. Peel backing from label and apply with firm, even pressure.

**INSTRUCTION LABEL**

(Refer to Figure 5 for the following information.)

Coin insert “A” has a separate validator opening, and insert “B” shows the validator opening built into the coin insert. Apply instruction label to area shown (as needed by the vendor).

**FLAVOR LABELS INSTALLATION:**

In Figures 6 & 7, corresponding styles are indicated by A, B, C, D, E, or F notations. Insert flavor labels to the side or top of selection window or button depending on the style. See Figure 6 for selection style. Rear views of windows and buttons are shown in Figure 7. Arrows point the direction to insert labels. Selection window and selection button labels identify product contained in stack columns.

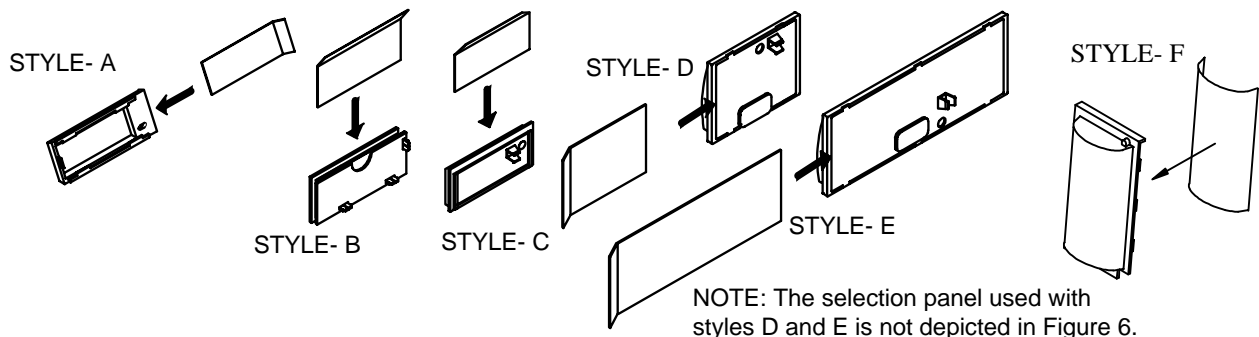

NOTE: The selection panel used with styles D and E is not depicted in Figure 6.

FIGURE 7

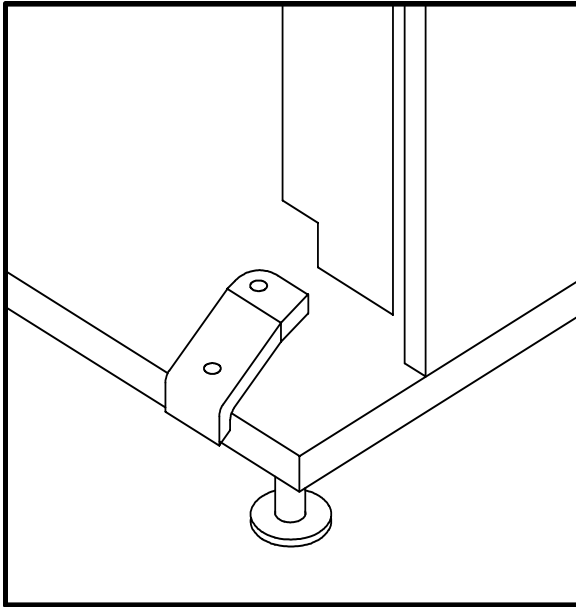

**FIGURE 8**

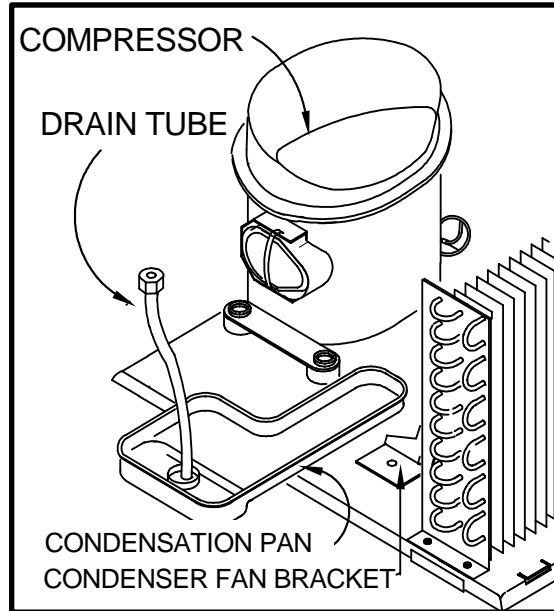

**FIGURE 9**

## **ALIGNMENT CHECKS**

### **DOOR RAMP CHECK:**

The door support is to insure that the outer door closes squarely to the cabinet. Raising the door can also insure proper alignment of the door latch (see Figure 8).

### **REFRIGERATION AREA CHECK:**

Check the position of the condensation pan (see Figure 9). The correct position of the pan is between the compressor and the condenser fan bracket. Be sure the drain tube is clipped to the pan and is free of kinks. A water trap is installed into the condensation pan and will prevent warm, moist air from reaching the evaporator area.



## LOADING INSTRUCTIONS

### **BASIC LOAD SET-UP:**

The V-Max machine is capable of vending a variety of products. For specific information, refer to the product set-up label on the machine inner door or contact the Technical Services Department of the Vendo office in your area.

Load product evenly. Bottles are loaded with crown end placed toward the back of the column. In initial loading, prime the machine by advancing the product into the buckets. To advance product into buckets, use the vend test function of the electronic controller. When the bucket is loaded, the column is ready to vend.

**PRIME ALL COLUMNS DURING INITIAL PRODUCT LOADING**



## VEND MECHANISM PARTS DESCRIPTION

The parts listed below are part of the vend motor mechanism (refer to Figure 10 on page G-9). One mechanism is required per column. The parts are interchangeable. Settings will differ between single, double, triple, and quadruple depth.

### **VEND MOTOR ASSEMBLY: P/N 1115821**

The motor is attached to the mech. plate by three screws.

### **TIMING CAM: P/N 1113236, RETAINER: P/N 1113244**

The motor cam assembly consists of two parts, the cam and the cam retainer. The cam controls the vend cycle. The cam is attached to the motor by the cam retainer. The retainer rotates left or right, and provides for single, double, triple, or quadruple depth operation.

### **SOLD-OUT SWITCH: P/N 368299**

There is one sold-out switch above the vend motor. The sold-out switch is actuated by the sold-out flap when the column is empty. It prevents the motor from running when the columns are empty.

### **STEEL BUCKET: P/N 1120146**

The vend bucket holds the product(s) in a "ready to vend" position at the base of each column.

### **MOTOR COUPLING: P/N 1076465**

The adapter coupling couples the motor to the bucket. It is located behind the motor, on the motor shaft.

### **ANTI-THEFT CLIP: P/N 389712**

The anti-tilt clip prevents product from dropping out of the bucket if the vendor is tilted. The anti-theft clips are located in the bucket.

### **GATE: P/N 1121282**

The gate holds product above the vend bucket.



**GATE LINK: P/N 1120140**

The rotation of the vend bucket moves the gate link. This opens the gate, allowing one layer of product to drop into the bucket.

**GAGE BAR: P/N 1111651**

The gage bar holds the product(s) inside the bucket. It also regulates which product is vended first when double, triple or quadruple settings are used (See page G-10 for motor cam settings).

**GAGE BAR CLIPS: P/N 1066104(white), 1066112(black), 1066112-1(gray), 1121704(gray), 1122103(black)**

Gage bar clips are attached to the gage bar to create multiple steps when vending product double, triple, or quadruple depths. (See product set-up label on inner door for details.)

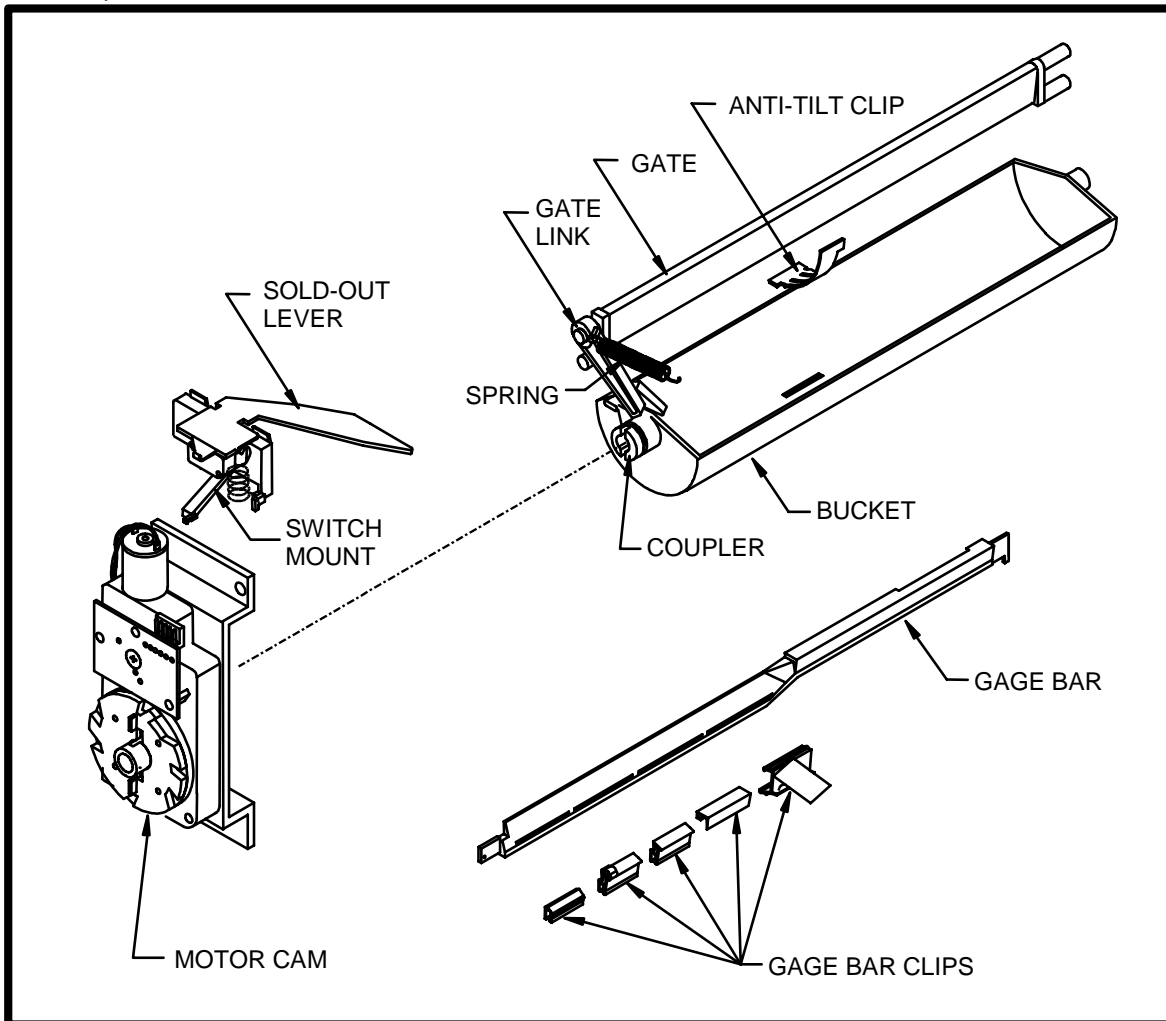

**FIGURE 10**



## VEND CYCLE

Several operations take place during the vend cycle. When a selection is made, the cam and bucket rotate, product is dispensed and the bucket is then reloaded. The sequence of these operations changes slightly when the column's depth setting is changed. With the single-depth setting, one purchase is made and the bucket is reloaded. The cam sequence occurs one time per bucket revolution. With the double-depth setting, two purchases are made before the bucket is reloaded, and the cam sequence occurs twice per bucket revolution. With triple-depth setting, three purchases are made and the cam sequences three times per bucket revolution. With quadruple-depth setting, four purchases are made and the cam sequences four times per bucket revolution.

### **PURCHASE SEQUENCE:** (See Figure 11, quadruple-depth setting pictured)

- PS 1. Customer inserts money.
- PS 2. The coinage reports credit to the vending machine electronic controller. Established credit is displayed on the digital display located near the coin insert slot.
- PS 3. Customer presses a selection button.
- PS 4. The controller receives the signal from the selection switch and (if sufficient credit exists), energizes the corresponding vend motor.
- PS 5. The vend motor rotates the bucket and cam. As the cam rotates, the motor position switch actuator raises to the outer surface of the cam. This closes the switch, which signals the controller to remove credit.
- PS 6. Product is immediately dispensed. The motor and cam continue to rotate until the motor position switch actuator drops into the low part of the cam.
- PS 7. Motor stops.

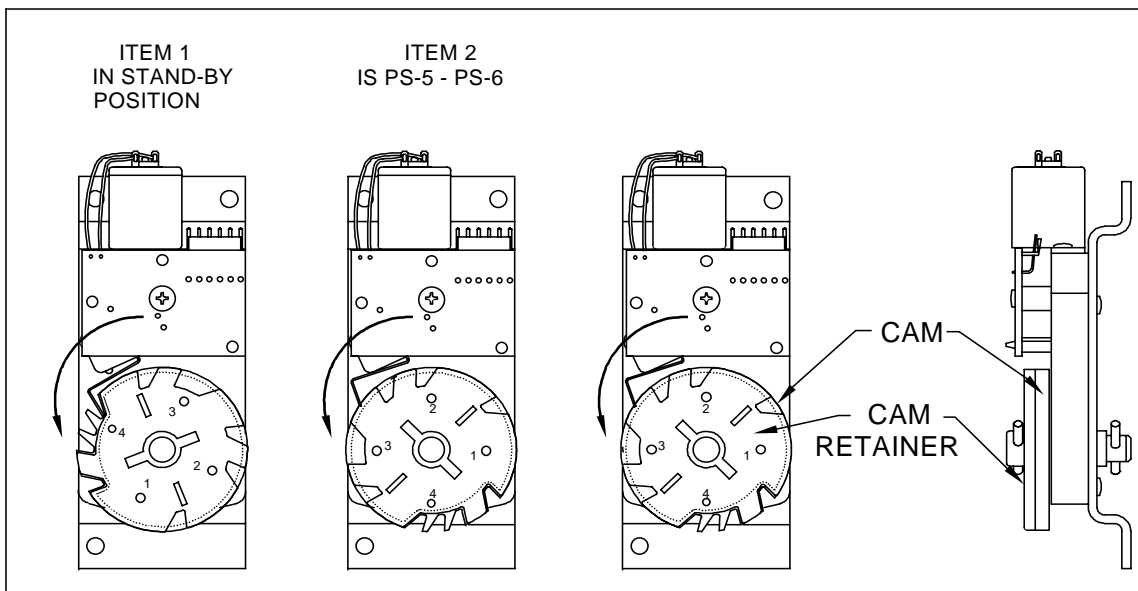

**FIGURE 11**

**NOTE:** The numbers on the cam reflect the number of vends allowed per cycle.



## RELOADING SEQUENCE (See Figure 12.)

- RS 1. The gate link rests at a locked position in a cut-out on the mech. plate. This locked position prevents the gate from opening out of sequence.
- RS 2. The gate link is guided by a slot in the mech. plate and is actuated by a ridge on the bucket. As the bucket turns, the link is moved out of the locked position.
- RS 3. As the link rises, the gate is opened. The spring maintains pressure on the link and the gate.
- RS 4. Product falls into the bucket, the link returns to the locked position and the gate is closed.
- RS 5. The bucket releases the gate link causing the gate to rest against the product.
- RS 6. As the product falls into the bucket, the link returns to the locked position and the gate is closed.
- RS 7. The product remaining in the column is held by the closed gate, keeping it above the bucket.
- RS 8. The bucket stops, loaded with product, and is ready to vend.

**FIGURE 12**

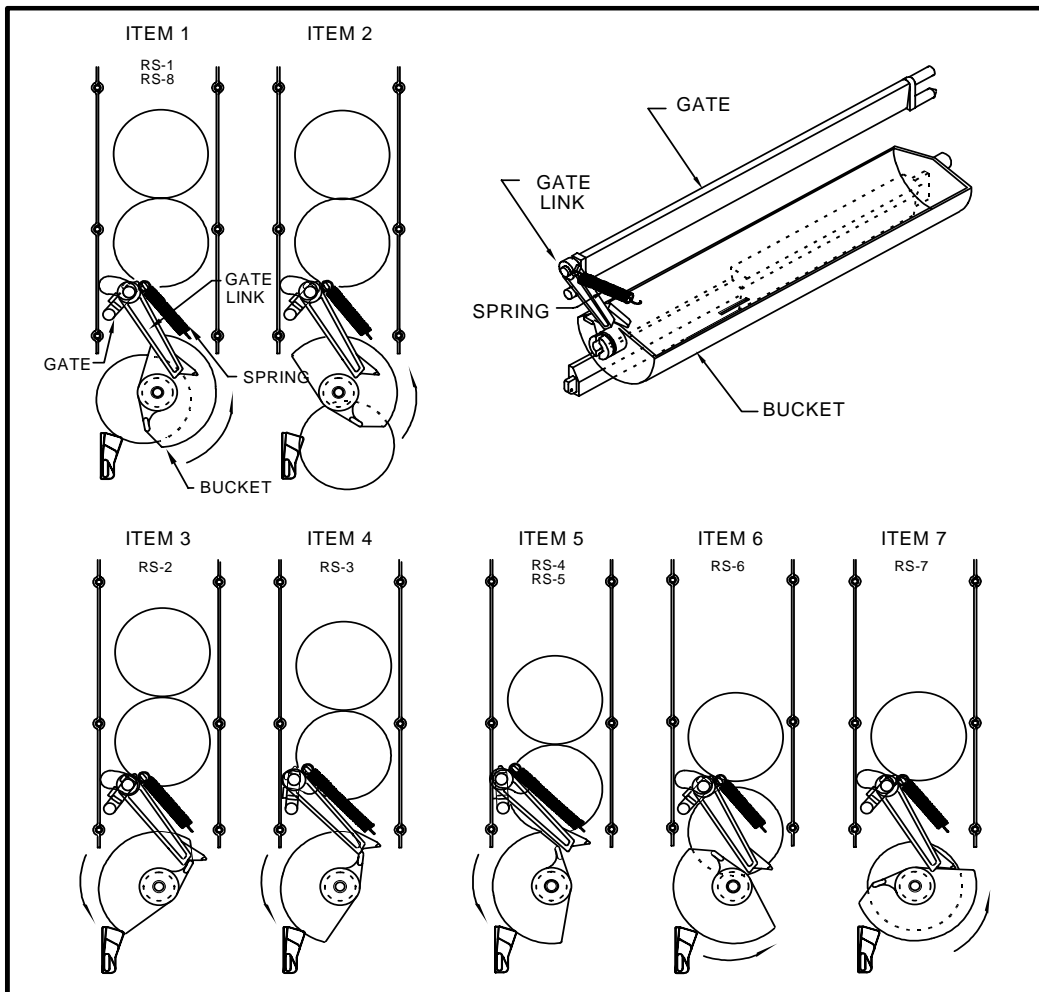



## NOTES



# **V-MAX**

## **9.2 PROGRAMMING SECTION**



All programming of the V-Max is done in the service mode as indicated in the following steps below. The main service modes are indicated in white text and the sub-modes are indicated in black text.

*Example:*

**tIne** Time/Date Setting Mode

**YeAr** Year Setting

**nth** Month Setting

**dATe** Date Setting

**Hour** Hour Setting

**Dst** Daylight Saving Time



## FOUR-BUTTON PROGRAMMING

All programming of the V-Max options is done in the service mode. To enter the service mode, open the vendor door and press and release the service mode button, which is located on the control board. (See Figure 1.)

The first four selection buttons are used to navigate through the programming as follows:

Button	Description	Usage
Selection Button 1	Abort	Escape, Cancel
Selection Button 2	Up	Increase, Next
Selection Button 3	Down	Decrease, Previous
Selection Button 4	Enter	OK, Accept, Save

The control board will automatically return to the open door sales mode if:

1. No information from the selection switches is received within approximately five minutes.
2. The service mode button is pressed a second time.
3. The (Abort) button is pressed.
4. The "rtn" function is activated.
5. No information from the selection switch is received within 30 seconds while "rtn" is being displayed.

If the door is closed, the control board will exit the service mode and return to the sales mode. When the programming is entered, any established credit is returned to the customer.



# V-MAX CONTROL BOARD

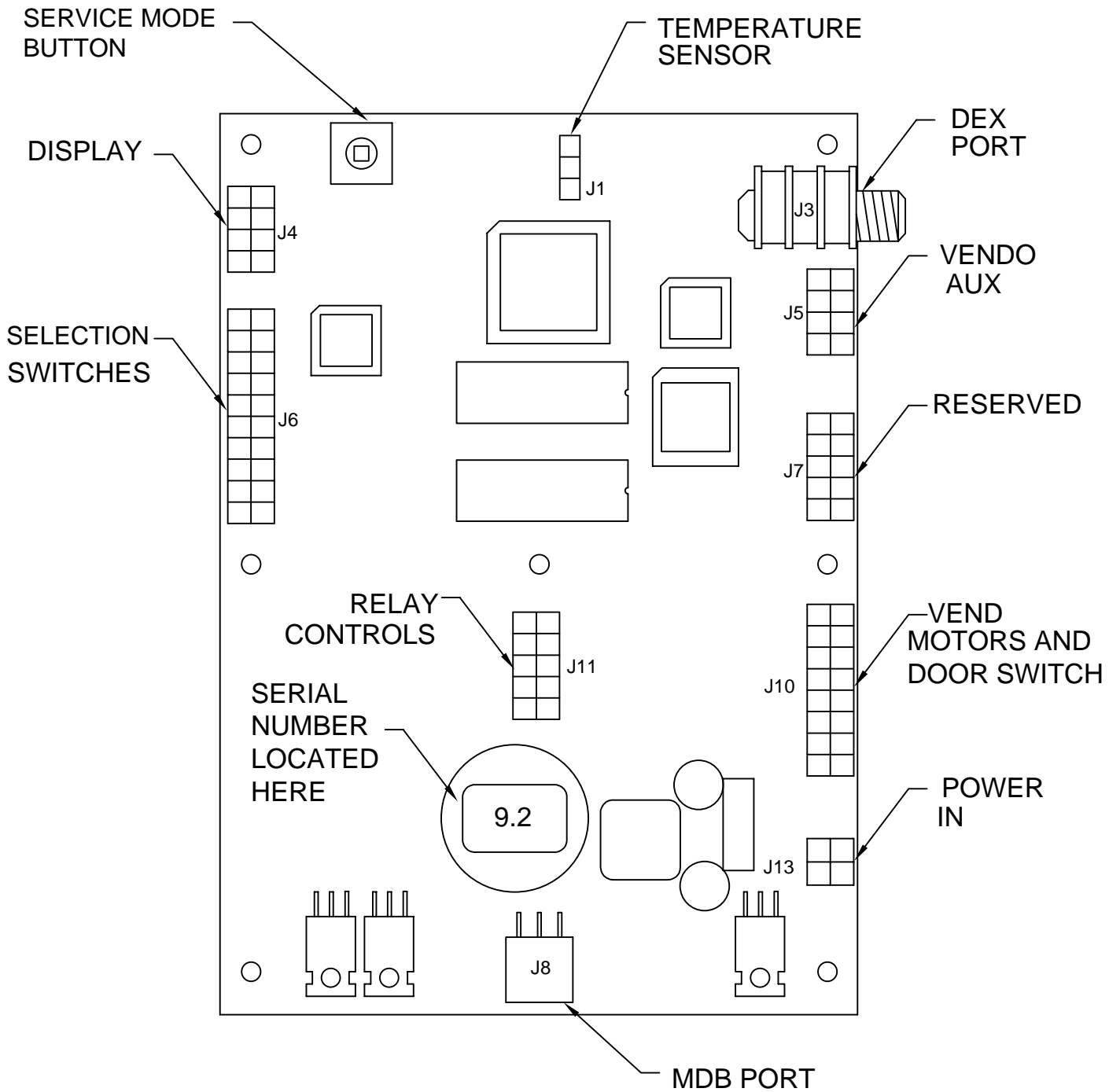

Figure 1



## SET-UP AND CODE DESCRIPTION

### **Error** Error Display Mode

If (Enter) is pressed at the “**Error**” prompt, the control board will enter the error display mode. If no errors have occurred, the display will show “**none**”. If an error has been detected since the last error reset, the display will show the first error summary code that has occurred.

**EXAMPLE:** “**UEnd**” would indicate “**COLJ**” (a column jam error).

If (Enter) is pressed, the control board will display detailed error for the summary code. Pressing (Up and Down) will cycle through any remaining error detail codes. If (Abort) is pressed while displaying any detailed code, the control board will return to the summary code. If (Abort) is pressed while displaying any summary code, the control board will return to the “**Error**” prompt.

**Note:** See Figure 2 for Error Code Map.

### Clearing an Error

If (Enter) is pressed and held for two seconds during the display of the detailed error code, that error will be cleared. If other currently accessed detailed errors exist, the next error will now be displayed. If no other errors of this type exist, the next error summary code will now be displayed, or “**none**” if no other errors exist.

### **CPO** Coin Pay-out Mode

If (Enter) is pressed at the “**CPO**” prompt, the control board will enter the coin pay-out mode and display the lowest coin value that can be paid out (.5, .10, .25 etc.) The (Up or Down) selection buttons will allow the operator to cycle through the coin tube selections. If (Enter) is pressed, a pay out of the displayed value will be made. Coins will continue to pay out as long as (Enter) is held down. If (Abort) is pressed at any time, the control board will return to the “**CPO**” prompt.

**EXAMPLE:** If (Enter) is pressed while .05 is displayed a nickel will be paid out.

### **tuFL** Tube Fill Mode

If (Enter) is pressed at the “**tuFL**” prompt, the control board will enter the coin tube fill mode. In this mode, the operator is allowed to deposit any coin into the coin changer’s acceptor when that coin’s tube is not full. The tube inventory level will be displayed after each coin is accepted. If (Abort) is pressed at any time during this operation, the control board will return to the start of the “**tuFL**” prompt.



<b>Error Codes</b>			
Summary level error codes (as displayed)			Error codes are cleared by pressing the ENTER button for 2 sec. when displayed or automatically by the following activities:
	Detailed level error codes		
		<b>Description</b>	
nonE		No error exists	
Uend		Vend mechanism summary error	
	CJXX	Column jam in column XX	Complete a test cycle for column
Ctrl		Control system summary error	
	dS	Door switch	Door closes
	rAn	RAM check sum of service mode settings	Change any service mode setting
	ACLO	AC supply low	
	SF	Scale factor incompatibility	Scale factor corrected
	IS	Machine inlet chute sensor is blocked	Blockage removed
	lb	Machine inlet chute is blocked	Coin detected by changer
SEL		Selection switch summary error	
	SLXX	Selection switch error in switch XX	Switch opens
StS		Space to sales summary error	
	UAXX	Unassigned column for column XX	Column is assigned
CHAR		Changer summary error	
	CC	No changer communication	Proper communication
	tS	Tube sensor error	Changer corrected
	IC	Changer inlet chute blocked	A coin is sensed
	tJXX	Tube payout jam in coin type XX	Changer corrected
	CrCH	Changer ROM check sum error	Changer corrected
	EE	Excessive escrow attempts	A valid coin is sensed
	nJ	Coin jam	A coin is sensed
	LA	Acceptance rate below 80%	Acceptance rate improves above 80%
	dIS	Disconnected acceptor	Acceptor properly connected
	rou	Coin routing error	Coin is routed properly
bUAL		Bill validator summary error	
	bC	No bill validator communication	Proper communication
	bFUL	Bill validator stacker full	Receive stacker command
	bILL	Defective bill validator motor	Validator becomes enabled
	bJ	Bill validator jammed	Validator becomes enabled
	brCH	Bill validator ROM check sum error	Validator becomes enabled
	bOPn	Bill validator stacker is open or out of position	Validator becomes enabled
	bS	Bill validator sensor error	Validator becomes enabled
Crdr		Card reader summary error	
	CrC	No card reader communication	Proper communication
	CrXY	Card reader non-transient error: code X sub-code Y	Error stops being reported
rFrG		Refrigeration summary error	
	SEnS	Temperature sensor defective or unplugged	
	COLd	Cabinet temperature 3 deg. F below low limit	Temperature rises above low limit
	Hot	Cabinet temperature 3 deg. F above high limit	Temperature falls below high limit
	CnPr	Cooling system not cooling	System cools 1 deg. F per hour
	Htr	Heating system not heating	System heats 1 deg F per hour

Figure 2



## SET-UP AND CODE DESCRIPTION (CONTINUED)

### **tEst**

#### **Test Mode**

If (Enter) is pressed at the “tEst” prompt, the control board will enter the test mode option. Upon entry into the test mode the display will show the first summary test, “Uend”. Pressing (Up or Down) will cycle through the available tests as listed below. Pressing (Enter) will enter the detailed test mode option. Pressing (Abort) while a summary test prompt is displayed will return the control board to the “tEst” prompt. Pressing (Abort) at the “tEst” prompt has no effect.

TEST OPTIONS	
“Uend”	Test vend motor
“SL”	Test selection switch
“SO”	Test sold-out switches
“dSP”	Check display/LED
“rELY”	Check compressor, fan, lights and heater relays

### **Uend**

#### **Test Vend Motor**

If (Enter) is pressed at the “tEst” prompt, the “Uend” mode is displayed. If (Enter) is pressed at the “Uend” prompt, the control board will enter the column vend test option. Upon entry into this setting the display will show “CO 1”. This will indicate that a test vend of column 1 may be done. Pressing (Up or Down) will toggle through the available columns. Pressing (Enter) will test vend the displayed column. Pressing (Abort) will return the control board to the “Uend” prompt.

### **SL**

#### **Selection Switch Test**

If (Enter) is pressed at the “SL” prompt, the control board will enter the selection switch test option. Upon entry into this setting the display will show “SE 4”. This indicates that the fourth button was pressed last. The last selection switch pressed will remain on the display until the service mode timer expires or the (Abort) button is pressed and held for two seconds. This will return the control board to the “SL” prompt.

### **SO**

#### **Sold-out Switch Test**

If (Enter) is pressed at the “SO” prompt, the control board will enter the sold-out test option. Upon entry into this setting the display will show “C 10”. This indicates that column 1 is not sold-out. If display shows “C 11” this will indicate that the displayed column is sold-out. Pressing (Up or Down) buttons will toggle through the columns. Pressing (Abort) will return the control board to the “SO” prompt.

**EXAMPLE:** “0” = Column is not Sold-out.  
“1” = Column is Sold-out.

## SET-UP AND CODE DESCRIPTION (CONTINUED)



## **dSP** Check Display/LED

If (Enter) is pressed at the “dSP” prompt, the control board will enter the display test option. Upon entry into this setting the display will toggle through all the vertical and horizontal display elements within each digit. The test will continue until the service mode timer expires or the (Abort) button is pressed. This will return the control board to the “dSP” prompt.

## **reLY** Check Compressor, Light and Heater Relays

If (Enter) is pressed at the “reLY” prompt, the control board will enter the relay test option. Upon entry into this setting the display will show the state of the first relay, “CnP0”. This means the relay is not activated and ‘1’ means the relay is activated. Pressing (Enter) will toggle the state of the relay. Pressing (Up or Down) will toggle through the available relays as listed below. Pressing (Abort) will return the control board to the “reLY” prompt. **NOTE:** *All relays will be returned to their initial state, “0”, upon the exit of this test routine.*

**EXAMPLE:** “0” = Means relay is de-activated.  
“1” = Means relay is activated.

RELAY LIST	
“CnP”	Controls the compressor relay
“Lit”	Controls the sign front light relay
“Htr”	Controls the heater relay ( <i>optional kit</i> )

**Note:** Pressing (Enter) will return you to “tEst” prompt, pressing (Up) will get you into “PASS”.

## **PASS** Password Protection

“PASS” will display only if the password has not been entered. The password is entered via the first four selection buttons while the control board is displaying “PASS”. The password must be entered within 10 seconds in the following order: 4-2-3-1. The display will go blank after the first selection button is pressed. After completing the sequence, press (Enter). If the password is not recognized, the display will remain blank.

## **CASH** Cash Counter Display Mode

If (Enter) is pressed at the “CASH” prompt, the control board will enter the non-resettable cash counter mode by displaying “CASH”. Pressing (Enter) will display cash total over the control board’s life. A decimal will be displayed in the appropriate position. Pressing (Up or Down) will change the display to “CA N”/“XXXX” where “N” is a selection number and the “XXXX” will be replaced with the current re-settable cash amount. Using the (Up or Down) will cycle through the available selections. If (Abort) is pressed at anytime during this operation, the control board will return to the “CASH” prompt.

### SET-UP AND CODE DESCRIPTION (CONTINUED)



## **SALE** Vend Counter Display Mode

If (Enter) is pressed at the "SALE" prompt, the control board will enter the non-resettable vend counter display mode by displaying "SALE". Pressing (Enter) will display the number of all paid vends over the control board's life. Using (Up or Down) will cycle through each selection as "SL 1"/"0000." where the "1" indicates the selection and the '0's represent the resettable number of vends for that selection. A decimal will be displayed in the appropriate position. If (Abort) is pressed anytime during this operation, the control board will return to the "SALE" prompt.

## **PrIC** Selection Price Setting Mode

If (Enter) is pressed at the "PrIC" prompt, the control board will enter the selection price setting mode. The display will show "Pr 1" if the machine is in multi-price mode, or "SPri" if the machine is in single-price mode.

In the multi-price mode, individual selection prices can be changed using the (Up or Down) to display "PrXX" where 'XX' is the selection number, or choose "ALL" to change the prices for all selection. If (Enter) is pressed, the display will show the current price for the displayed selection. Using (Up or Down) will increase or decrease the price. Holding (Up or Down) for more than five seconds will cause the price to change at 10 times the normal rate. While the desired price is on the display, press (Enter) and the price will be saved. Pressing (Abort) will return to the selection level without saving the new price.

## **StS** Space-to-Sale Programming Mode

If (Enter) is pressed at the "StS" prompt, the control board will enter the space-to-sales (StS) programming mode by displaying "OPTX" where 'X' is the current option selected. Using (Up or Down) will allow the operator to cycle through the available space-to-sales options "Opt1"- "Opt9" and "CSTS". When one of the options, "Opt1"- "Opt9", is on the display, pressing (Enter) will select that space-to-sale option and return to the "STS" prompt. If one of the "Opt1"- "Opt9" option is displayed and (Abort) is pressed, the user will return to the "STS" prompt without changing any settings. **NOTE: "Opt1", "Opt2", "Opt8", "Opt9" are the only configuration settings recommended. Factory setting is "Opt1".**

***For proper configuration settings refer to the label located on the inner door shear panel. (See figure 3)***



## SET-UP AND CODE DESCRIPTION (CONTINUED)

PRE- PROGRAMMED SPACE - TO - SALES									
SEL #	COLUMNS								
1	1,2	1,2	1,2	1,2	1,2,3	1,2,3	1,2	1,2,3	ALL
2	3	1,2	1,2	1,2	1,2,3	1,2,3	3,4	1,2,3	ALL
3	4	3,4	3	1,2	1,2,3	1,2,3	5	4,5	ALL
4	5	5	3	1,2	1,2,3	1,2,3	6	6	ALL
5	6	6	4	3	4	4,5	7	7	ALL
6	7	7	4	4	4	4,5	8	8	ALL
7	8	8	5	5	5	6	9*	9*	ALL
8*	9*	9*	6	6	6	6	10*	10*	ALL
9*	10*	10*	7	7	7	7	1,2	1,2,3	ALL
10*	~	~	8	8	8	8	~	~	~
11*	~	~	9*	9*	9*	9*	~	~	~
12*	~	~	10*	10*	10*	10*	~	~	~
13*	~	~	1,2	1,2	1,2,3	1,2,3	~	~	~
OPTION	1	2	3	4	5	6	7	8	9

\* IF PRESENT

**Figure 3**

### **CStS** Custom Space-to-Sales Mode

If (Enter) is pressed at the “CStS” prompt, the control board will enter the custom space-to-sales (CStS) programming mode by displaying “SLXX” where ‘XX’ is the current selection for that certain button, alternating with either “none” indicating that no columns are assigned to the displayed selection button or the display will scroll through a sequence of numbers that represents the columns that are currently assigned to the selection button. Using (Up or Down) will cycle through all the available selections and then “SAUE”. Pressing (Abort) will go immediately to the “SAUE” prompt, when pressing the (Abort) button will return the control board to the “CStS” prompt without changing any settings. Pressing (Enter) while “SAUE” is displayed will save all changes and return the control board to the “StS” prompt.

Pressing (Enter) while the “SLXX” prompt is displayed will allow columns to be assigned to the current selection. The display will show “Cnn” where “nn” is a column number. Using (Up or Down) will cycle through all the available columns. Pressing (Enter) at any column will enter the edit mode. The display will show “CnnX” where “X” will either be flashing “0”(disabled) or “1”(enabled) to assign the columns (“nn”) to the current selection. Using (Up or Down) will change the assignment status of the columns. Pressing (Abort) will return the control board to the “Cnn” prompt without changing the status of the column, while pressing (Enter) saves the displayed status of the column before returning to the “Cnn” prompt. Pressing (Abort) at the “CnnX” prompt returns the control board to the “SLXX” prompt.

**EXAMPLE:** “Cnn0” = The selection is disabled.

“Cnn1” = The selection is enabled.



## SET-UP AND CODE DESCRIPTION (CONTINUED)

### Con

#### Machine Configuration Mode

If (Enter) is pressed at the “Con” prompt, the control board will enter the machine configuration mode by displaying “C1 X” which indicates configuration options number 1 and the “X” is the current status of that setting. If “X” is 1 then status is active, if “X” is “0” then the status is not active. If (Abort) is pressed while at the “C1 X” prompt the control board will return to the “Con” prompt. Pressing (Up or Down) will toggle through the available configuration options. Pressing (Enter) saves the status of the current option and returns the user to the “Con” prompt. Pressing (Abort) returns the control board to the “Con” prompt without saving. (See Figure 4.)

**EXAMPLE:** “0” = The Con is disabled.

“1” = The Con is enabled.

CONFIGURATION SETTINGS		
CON#	DESCRIPTION	SETTINGS
C1	PRICE SETTING	0=SINGLE PRICE 1=MULTI PRICE
C2	OPTIONAL FEATURES	0=DISABLE OPTIONAL PROGRAM 1=ENABLE OPTIONAL PROGRAM
C3	POS MESSAGE	0=DISPLAY POS MESSAGE 1=TURN OFF POS MESSAGE
C4	DOOR OPEN MIS	0=DISPLAY SUMMARY ERROR CODES 1=DISPLAY SUMMARY SALES DATA
C5	MIS RESET	0=RESET MIS VIA DEX COMMAND ONLY 1=RESET MIS WHEN DOOR IS CLOSED
C6	RESERVED	
C7	SAVE CREDIT	0=SAVE CREDIT FOR 5 MINUTES 1=SAVE CREDIT INDEFINITELY
C8	FORCE VEND	0=NORMAL VEND 1=FORCE VEND
C9	MULTI VEND	0=SINGLE VEND 1=MULTI VEND
C10	BILL ESCROW	0=ENABLE BILL ESCROW 1=DISABLE BILL ESCROW

Figure 4



## SET-UP AND CODE DESCRIPTION (CONTINUED)

**C1**

### Single/Multi-Price Mode

Toggles between the single-price and multi-price modes. In the single-price mode, the price of selection 1 will be used for all selections. In the multi-price mode, each selection can be set to a different price.

“0” = Single pricing is used.

“1” = Multi-pricing is used.

**C2**

### Optional Feature Enable

This selection will allow optional features to be enabled and displayed in the current service mode menu. If any of the optional features described in this document are implemented, they must be able to be hidden by this selection. These features currently include “**bLC1**”, “**bLC2**”, “**DISC**” and “**OUER**”.

“0” = Option is Off.

“1” = Option is On.

**C3**

### LED Display Message Mode

Toggles between the LED display modes. In the display/LED mode, the current price will be displayed if in the single price mode. **Note:** *ICE COLD COCA COLA will scroll when the option is set at “0”.*

“0” = Display message is On.

“1” = Display message is Off.

**C4**

### Door Open MIS Mode

This option changes the Open-Door Mode Display. If enabled, the total machine sales and total machine cash values are displayed before the error codes. These values represent the number of all paid vends and the cash amount of all paid vends, respectively. The sales and cash values are displayed the same as in the “**SALE**” and “**CASH**” service mode functions. The display shows “**SALE**”/”0000”/”0000” for two seconds on the display/LED, then “**CASH**”/”0000”/”00.00”, then “**Error**” or “**nonE**”. If this option is disabled, existing errors are displayed, or “**nonE**” for no detected errors.

“0” = Existing errors or “**nonE**” is displayed.

“1” = “**SALE**”/”0000”/”0000”

“**CASH**”/”0000”/”00.00” and “**Error**” or “**nonE**”.



## SET-UP AND CODE DESCRIPTION (CONTINUED)

**C5**

### MIS Reset Mode

This option is used to allow the door switch to reset all re-settable MIS. It will be reset only if the "CASH" and "SALE" mode were entered.

"0" = All re-settable MIS registers will be reset only when the "CF" command is received from the HHC.

"1" = All re-settable MIS registers are reset when the door switch is activated if any of the re-settable MIS registers are read.

**C6**

### RESERVED FOR FUTURE PROGRAMMING.

**C7**

### Save Credit Mode

This option is used to determine how long credit should be maintained on the display and available to the customer. If "Save Credit" is enabled it will register the credit for no more than five minutes, after the vend is aborted and returns to standby.

"0" = Clears credit in five minutes.

"1" = Credit remains.

**C8**

### Force Vend

Prevents the machine from making change without a selection being attempted. When this mode is enabled, escrow of coins is allowed until any of the following:

- A. Any bill is inserted into the bill acceptor;
- B. Any "cash box" coin (a coin that is not assigned to a tube) is inserted, or;
- C. The maximum vend price is reached. Once any of these conditions are met, an escrow request is ignored and a vend must be made.

If a selection is made that is sold-out or locked out, this option will be overridden and an escrow request will be honored.

**NOTE:** Force vend has no effect on the card reader. Once a card is inserted, it can always be returned to the customer via an escrow or the return switch on the card reader.

"0" = Force-vend is disabled.

"1" = Force-vend is enabled.



## SET-UP AND CODE DESCRIPTION (CONTINUED)

**C9**

### Multi-Vend

Allows multiple purchases without re-entering coins. If enabled, instead of returning the change after a vend, the credit will remain on the display to be used for another selection. An escrow will be honored at any time. This option will take precedence over the force-vend option after the first vend has been completed.

“0” = Multi-vend is disabled.

“1” = Multi-vend is enabled.

**C 10**

### Bill Escrow Mode

Allows the escrow of bills. If enabled and the bill value inserted takes the accumulated credit over the maximum price, the bill will be held in the escrow position. If the rule is disabled, bills will always go to the stacker.

“0” = Bill escrow is disabled.

“1” = Bill escrow is enabled.

**CCOC**

### Correct Change Only Control

Allows the customer to disable or enable the overpay routine.

If “**Con0**”, Consumer overpay routine disabled for USA.

If “**Con1**”, Can be enabled for International use.

If “**CCU**”, “Correct Change Value” is the value that the control board has the ability to control the “Use Correct Change Only” option.

If “**ACC**”, “Unconditional Acceptance Value” is the largest value of any single form of currency that can be accepted without knowledge that the equivalent value of coins can be returned. This option applies to coins or bills.

**PrEU**

### Preview Vend Password Setting Mode

If (Enter) is pressed at the “**PrEU**” prompt, the control board will display the current password for the preview vend mode. The first digit of the number will be flashing. Pressing (Up or Down) will adjust the currently flashing digit up or down. Pressing (Enter) will save the currently flashing digit and the next digit of the password will begin flashing. All digits may be modified in this manner. Pressing (Enter) while the last digit is flashing saves the currently displayed password and return to the “**PrEU**” prompt. Pressing (Abort) at any time in the procedure returns to the “**PrEU**” prompt without saving.



## SET-UP AND CODE DESCRIPTION (CONTINUED)

### **LANg**

#### **Change Language**

If (Enter) is pressed at the “LANg” prompt, the control board will display the current language for the preview mode. Pressing (Up or Down) will toggle through the available languages listed below. Pressing (Enter) will activate the displayed language and return to the “LANg” prompt. Pressing (Abort) at any time in the procedure returns to the control board to the “LANg” prompt without changing the active language.

<b>LANGUAGE LIST</b>	
“EnG”	English - mandatory if supported
“Frn”	French - mandatory if supported
“Ger”	German - mandatory if supported
“ItA”	Italian - mandatory if supported
“Port”	Portuguese - mandatory if supported
“ESP”	Spanish - mandatory if supported
“SLO”	Slovene - mandatory if supported

### **tinE**

#### **Time/Date Setting Mode**

If (Enter) is pressed at the “tinE” (time) prompt, the control board will enter the time/date setting mode and display “Enb0” (disable) or “Enb1” (enable). Using (Up or Down) will allow the control board to cycle through all available time selection options. If (Abort) is pressed anytime during this operation, the control board will return to the “tinE” prompt.

<b>TIME SELECTION OPTIONS</b>	
“Enb1”	Enable/Disable time (Edit mode 0/1)
“YEAr”	Current Year (Example '02)
“dAtE”	Current Date (month, day)
“nth”	Current Month
“hour”	Current Time (hours, minutes)
“dSt”	Daylight Saving Time

### **YeAr**

#### **Year Setting Option**

If (Enter) is pressed at the “YEAr” prompt, the last two digits of the year are displayed and will be flashing. Pressing (Up or Down) will increase or decrease the year setting. Pressing (Enter) will save the displayed year setting and return the user to “YEAr”. Pressing (Abort) will return to “YEAr” without saving.

### **nth**

#### **Month Setting Option**

If (Enter) is pressed at the “nth” prompt, the control board will enter the month setting option. Upon entry into this option the display will show the current two-digit month setting, indicating the month of the year (example: 01-12). Pressing (Up or Down) will increase or decrease the month setting. Pressing (Enter) will save the displayed month setting and return the Control board to the “nth” prompt. Pressing (Abort) while the month digits are flashing returns to the “nth” prompt without saving the month.



## SET-UP AND CODE DESCRIPTION (CONTINUED)

### **dATE** Date Setting Option

If (Enter) is pressed at the “dATE” prompt, the current two-digit date (days of the month) is displayed. Pressing (Up or Down) will increase or decrease the date setting. Pressing (Enter) will save the displayed date and return to the “date” prompt. Pressing (Abort) while the date digits are flashing returns to the “date” prompt without saving the new date.

### **Hour** Hour Setting Option

If (Enter) is pressed at the “Hour” prompt, the current time is displayed in a 24-hour format. The left two digits of the display show the hour and the right two digits show the current minutes. While the hour digits are flashing, pressing (Up or Down) will increase/decrease the hour. Pressing (Enter) at this point will save the displayed hours and the minute digits will start to flash. While the minute digits are flashing, pressing (Up or Down) will increase/decrease the minutes. Pressing (Enter) at the point will save the displayed hours and minutes and return to the “Hour” prompt. Pressing (Abort) while the hour or minute digits are flashing returns to “Hour” without saving the hour or minutes.

### **Dst** Daylight Saving Time

If (Enter) is pressed at the “DSt” prompt, the current daylight saving time option will be displayed. Using (Up or Down) will toggle the different countries: **AUS** (Australian rules), **EU** (European rules), **OFF** (No daylight savings) and **NA** (North American rules). If (Enter) is pressed at this point, the current display option will be saved and the user will be returned to the “DSt” prompt. Pressing (Abort) returns to the “DSt” prompt without saving.

### **Lit** Light Control

If (Enter) is pressed at the “Lit” prompt the control board will enter the light control programming mode by displaying “Enb0”(disable) or “Enb1” (enable). Using (Up or Down) will allow the operator to cycle through all available time selection options. If (Abort) is pressed anytime during this operation, the control board will return to the code level.

LIGHT CONTROL OPTIONS	
“Enb1”	Enable/Disable light timer (Edit mode 0/1)
“Strt”	Set start time
“dAY”	Set days to time
“Hour”	Set time to start (24 hours)
“StoP”	Set stop time



## SET-UP AND CODE DESCRIPTION (CONTINUED)

### **EnbX**

#### **Set Enable/Disable**

If (Enter) is pressed at the “**Enbx**” prompt, the last digit of the prompt will start flashing. Pressing (Up or Down) will toggle from “1” (Enable) to “0” (Disable). Pressing (Enter) will save the displayed setting and return the user to “**EnbX**”. Pressing (Abort) will return to “**EnbX**” without saving.

“0” = Setting is disabled.

“1” = Setting is enabled.

### **Strt**

#### **Start Time Setting**

If (Enter) is pressed at the “**Strt**” prompt, the control board will enter the start time setting option. Upon entry into this option the display will show “**dAY**”. Pressing (Up or Down) will cycle through the available summary level codes. Pressing (Enter) will enter the detail level option. Pressing (Abort) while a summary level prompt is displayed will return the control board to the “**Strt**” prompt. Pressing (Abort) at the “**Strt**” prompt will return the control board to the “**Lit**” prompt.

### **dAY**

#### **Day Setting Option**

If (Enter) is pressed at the “**dAY**” prompt, the current day of the week is displayed. The days are displayed as follows:

“ <b>nonX</b> ”	Monday
“ <b>tuEX</b> ”	Tuesday
“ <b>WEdX</b> ”	Wednesday
“ <b>thuX</b> ”	Thursday
“ <b>FriX</b> ”	Friday
“ <b>SAtX</b> ”	Saturday
“ <b>SunX</b> ”	Sunday
“ <b>ALL</b> ”	All Days

“0” = Setting is disabled.

“1” = Setting is enabled.

Pressing (Up or Down) at this point will rotate through the days of the week. Pressing (Enter) when a day (e.g. **nonX**) is displayed will cause the “X” to flash. Pressing (Up or Down) will toggle from “0” (disable) to “1” (enable). If (Enter) is pressed, the displayed day is saved and the user is returned to the “**dAY**” prompt. Pressing (Abort) returns the control board to the “**dAY**” prompt without saving.



## SET-UP AND CODE DESCRIPTION (CONTINUED)

### Hour

#### Start Hour Setting

If (Enter) is pressed at the “Hour” prompt, the current time is displayed in a 24-hour format. The left two digits of the display will show the hour and the right two digits show the current minutes. While the hour digits are flashing, pressing (Up or Down) will increase/decrease the hour. Pressing (Enter) at this point will save the displayed hours and the minute digits will start to flash. While the minute digits are flashing, press (Up or Down) to increase/decrease the minutes. Pressing (Enter) at this point will save the displayed hours and minutes and return to the “Hour” Prompt. Pressing (Abort) while the hour or minutes digits are flashing returns to “Hour” without saving.

### Stop

#### Set Stop Time

If (Enter) is pressed at the “Stop” prompt, the control board will enter the stop time setting option. Upon entry into this option the display will show “dAtE”. Pressing (Up or Down) will cycle through the available summary level codes. Pressing (Enter) will enter the detail level option. Pressing (Abort) while a summary level prompt is displayed will return the control board to the “Stop” prompt. Pressing (Abort) at the “Stop” prompt will return the control board to the “Lit” prompt. **Note: To program days and hours refer to page CP-15.**

### rFrG

#### Refrigeration Control Mode

If (Enter) is pressed at the “rFrG” prompt, the control board will enter the refrigeration control option by displaying “EnbX” indicating the enable/disable setting mode. Using (Up or Down) will allow the operator to toggle between the following modes:

REFRIGERATION CONTROL OPTIONS	
“EnbX”	Enable/Disable Refrigeration timer (Edit mode 0/1)
“Strt”	Set start time
“dAY”	Set days to time
“Hour”	Set time to start (24 hours)
“StoP”	Set stop time
“dAY”	Set days to time
“Hour”	Set time to start (24 hours)

#### Temperature Setting

If (Enter) is pressed at the “rFrG” prompt, the control board will enter the refrigeration control option by displaying “EnbX” indicating the enable/disable setting mode. Using (Up or Down) will allow the operator to toggle between the following modes:

TEMPERATURE SETTING OPTIONS	
“dEGX”	Set Temperature (Edit mode Fahrenheit/Celsius)
“SEtP”	Temperature set point (Factory setting 35°F/ 1.5°C)
“Stor”	Storage temperature setting (Factory setting 60° F/15.5°C)
“dSPO”	POS temperature display (Edit mode 0/1)



## SET-UP AND CODE DESCRIPTION (CONTINUED)

**dEGX**

### Degree Setting

If (Enter) is pressed at the “dEGX” prompt, the control board will display “dEGX” where ‘X’ will be ‘F’ if the control board is currently in °F (Fahrenheit) mode or ‘C’ if the control board is currently in °C (Celsius) mode. Pressing (Up or Down) while the “X” digit is flashing will toggle the ‘X’ digit between ‘F’ and ‘C’. Pressing (Enter) will save the displayed temperature mode and return to the “dEGX” prompt. Pressing (Abort) will return to the “dEGX” prompt without saving.

**SEtP**

### Set Point Setting (35°F)

If (Enter) is pressed at the “SEtP” prompt, the control board will display “XX.XX” where ‘X’ will be the current set point temperature. Pressing (Up or Down) will increase/decrease by one degree increments. Pressing (Enter) will save the displayed temperature setting and return the user to the “SEtP” prompt. Pressing (Abort) will return to the “SEtP” prompt without saving.

**Stor**

### Storage Temperature Setting (60°F)

If (Enter) is pressed at the “Stor” prompt, the control board will display “XX.XX” where ‘X’ will be the current storage temperature. Pressing (Up or Down) will increase/decrease by one degree increments. Pressing (Enter) will save the displayed storage temperature setting and return the user to the “Stor” prompt. Pressing (Abort) will return to the “Stor” prompt without saving.

**dSP0**

### Display Temperature

If (Enter) is pressed at the “dSP0” prompt, the control board will enter into the LED temperature display enable option. Upon entry into this option the display will show the current setting “dSP0” where the “0” is flashing will disable the temperature from being shown in the LED or if “1” is flashing the temperature will be displayed in the LED following “ICE COLD COCA COLA”. Pressing (Up or Down) will toggle the digit between ‘0’ and ‘1’. Pressing (Enter) will save the currently displayed setting and return to the “dSP0” prompt. Pressing (Abort) will return to the “dSP0” prompt without saving.



## SET-UP AND CODE DESCRIPTION (CONTINUED)

### **BLC 1** Block Selection Setting

If (Enter) is pressed at the “bLC1” or “bLC2” prompt, the control board will enter the second bank of selection blocking control option. Upon entry into this routine the display will show the first summary level code “Enb0”. Pressing (Enter) will save the currently displayed setting and return the user to the “bLC1” prompt. Pressing (Abort) will return to the “bLC1” prompt without saving. Using (Up or Down) will let the operator toggle between the following modes:

**Note: “BLC1” will not be accessible when “C2” is set at “0”.**

“0” = Block option is disabled.

“1” = Block option is enabled.

BLOCK SELECTION OPTIONS	
“EnbX”	Enable/Disable selection blocking (Edit mode 0/1)
“Strt”	Set start time
“dAY”	Set days to time
“Hour”	Set time to start (24 hours)
“StoP”	Set stop time
“dAY”	Set days to time
“Hour”	Set time to start (24 hours)
“SEL”	Set selection time

### **dISC** Discount Setting Mode

If (Enter) is pressed at the “dISC” prompt, the control board will enter the discount control setting blocking control routine. Upon entry into this setting the display will show the first summary level code “Enb0”. If (Up or Down) is pressed it will cycle through the available summary level codes as listed below. Pressing (Enter) will save the currently displayed setting and return the user to the “dISC” prompt. Pressing (Abort) will return to the “dISC” prompt without saving. Using (Up or Down) will let the operator toggle between the following modes:

**Note: “dISC” will not be accessible when “C2” is set at “0”.**

“0” = Disabled discount setting.

“1” = Enabled discount setting.

DISCOUNT SETTING OPTIONS	
“EnbX”	Enable/Disable discount setting (Edit mode 0/1)
“Strt”	Set start time
“dAY”	Set days to time
“Hour”	Set time to start (24 hours)
“StoP”	Set stop time
“dAY”	Set days to time
“Hour”	Set time to start (24 hours)
“SEL”	Set selection time
“LESS”	Set Discount amount



## SET-UP AND CODE DESCRIPTION (CONTINUED)

### **SEL**

#### **Selection Setting**

If (Enter) is pressed at the “SEL” prompt, the control board will enter the selection setting option. Upon entry into this setting the display will show the current setting for selection as “01 1”, where “1” shows it is enabled or “0” if the option is disabled. If (Up or Down) is pressed it will cycle through the valid selections or “ALL”. Pressing (Enter) will save the currently displayed setting and return the control board to the “SEL” prompt. Pressing (Abort) will return the control board to the “SEL” prompt without saving.

“0” = Selection setting is disabled.

“1” = Selection setting is enabled.

### **LESS**

#### **Selection Setting**

If (Enter) is pressed at the “LESS” prompt, the control board will enter the discount amount option. Upon entry into this setting the display will show the current four digit discount amount. If (Up or Down) is pressed it will increase or decrease the lowest discount amount. Pressing (Enter) will save the currently displayed setting and return the user to the “LESS” prompt. Pressing (Abort) will return to the “LESS” prompt without saving.

### **OUEr**

#### **Over-Ride Option Mode (Units equipped with optional key switch)**

If (Enter) is pressed at the “OUEr” prompt, the control board will enter the over-ride option. Upon entry into this setting the display will show the first summary level code “FrEX”. If (Up or Down) is pressed it will cycle through the available summary level codes as listed below. Pressing (Enter) will save the currently displayed setting and return the user to the “OUEr” prompt. Pressing (Abort) will return to the “OUEr” prompt without saving. Using (Up or Down) will let the operator toggle between the following modes:

“0” = Disabled over-ride option.

“1” = Enabled over-ride option.

**Note: “OUEr” will not be accessible when “C2” is set at “0”.**

<b>OVERRIDE SETTING OPTIONS</b>	
“FrEO”	Enable/Disable free vend (Edit mode 0/1)
“bLCO”	Selection blocking over-ride
“dSCO”	Discounting over-ride
“LitO”	Lighting control over-ride
“FrGO”	Refrigeration control over-ride



## SET-UP AND CODE DESCRIPTION (CONTINUED)

### **FrEO**

#### **Over-Ride Free Vend**

If (Enter) is pressed at the “FrEO” prompt, the control board will enter the free vend enable option. Upon entry into this setting the display will show the current setting “FrEO”. Pressing (Up or Down) will toggle between ‘0’(disable) or ‘1’(enable). Pressing (Enter) will save the currently displayed setting and return to the “FrEO” prompt. Pressing (Abort) will return to the “FrEO” prompt without saving.

“0” = Disabled free vend.

“1” = Enabled free vend.

### **BlcO**

#### **Over-Ride Selection Blocking**

If (Enter) is pressed at the “blcO” prompt, the control board will enter the selection blocking over-ride enable option. Upon entry into this setting the display will show the current setting “blcO”. Pressing (Up or Down) will toggle between ‘0’ (disable) or ‘1’ (enable). Pressing (Enter) will save the currently displayed setting and return the user to the “blcO” prompt. Pressing (Abort) will return to the “blcO” prompt without saving.

“0” = Disabled selection blocking.

“1” = Enabled selection blocking.

### **dScO**

#### **Over-Ride Discount**

If (Enter) is pressed at the “dScO” prompt, the control board will enter the discounting over-ride enable option. Upon entry into this setting the display will show the current setting “dScO”. Pressing (Up or Down) will toggle between ‘0’ (disable) or ‘1’ (enable). Pressing (Enter) will save the currently displayed setting and return to the “dScO” prompt. Pressing (Abort) will return to the “dScO” prompt without saving.

“0” = Disabled discount over-ride.

“1” = Enabled discount over-ride.

### **LitO**

#### **Over-Ride Lighting Control**

If (Enter) is pressed at the “LitO” prompt, the control board will enter the lighting control over-ride enable option. Upon entry into this setting the display will show the current setting “LitO”. Pressing (Up or Down) will toggle between ‘0’ (disable) or ‘1’ (enable). Pressing (Enter) will save the currently displayed setting and return to the “LitO” prompt. Pressing (Abort) will return to the “LitO” prompt without saving.

“0” = Disabled lighting control.

“1” = Enabled lighting control.



## SET-UP AND CODE DESCRIPTION (CONTINUED)

**FrGO**

### Over-Ride Refrigeration Control

If (Enter) is pressed at the "FrGO" prompt, the control board will enter the refrigeration control over-ride enable option. Upon entry into this setting the display will show the current setting "FrGO". Pressing (Up or Down) will toggle between '0' (disable) or '1' (enable). Pressing (Enter) will save the currently displayed setting and return to the "FrGO" prompt. Pressing (Abort) will return to the "FrGO" prompt without saving.

"0" = Disabled refrigeration control over-ride.

"1" = Enabled refrigeration control over-ride.



## 9.2 WIRING DIAGRAM (COCA-COLA)

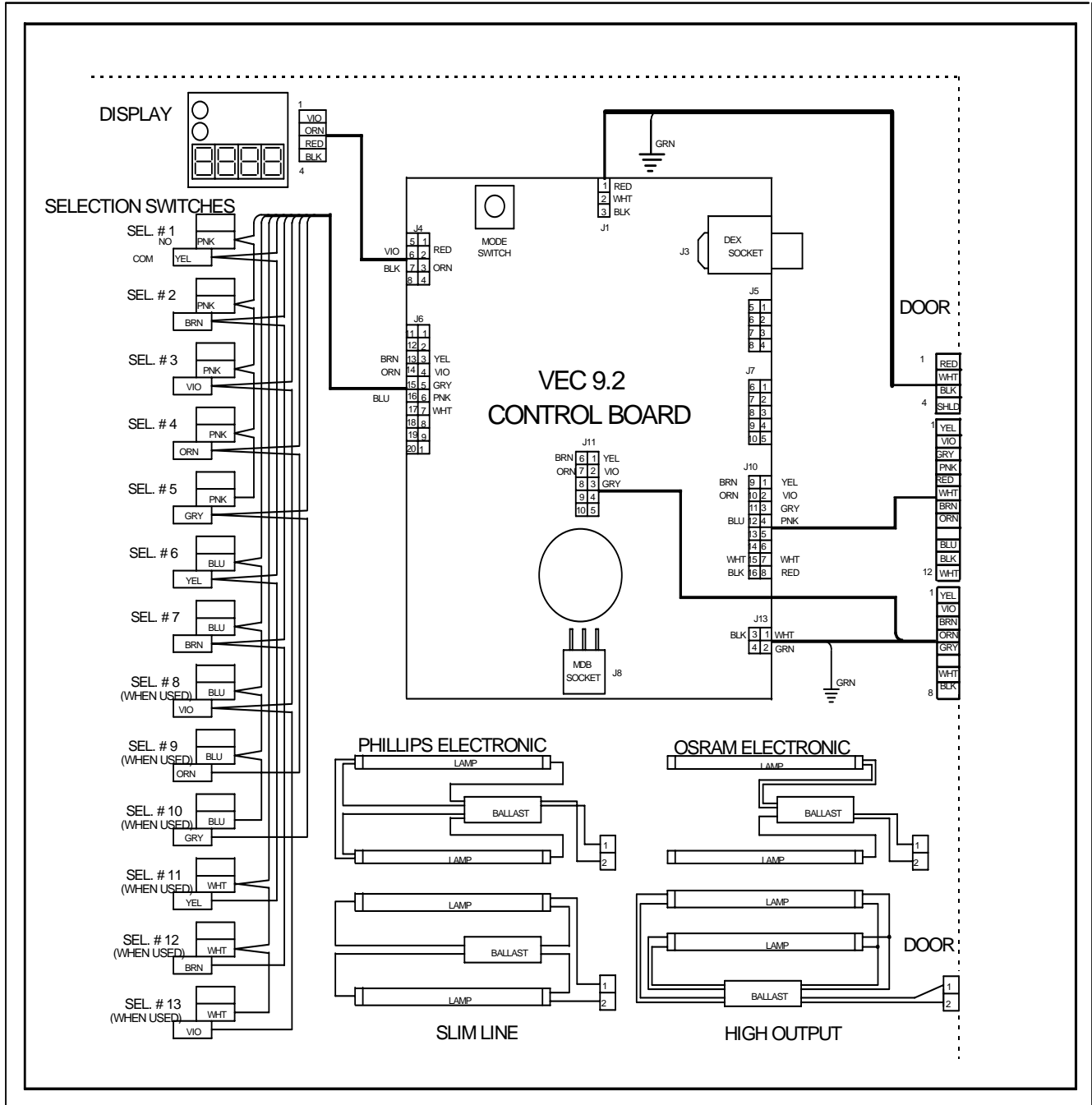

### VOLTAGE READINGS

J1 - Temp Sensor 5 Volts DC Pins 1 and at 2	J8 - MDB Port 34 Volts DC Pin 1 5 Volts at Pin 6
J3 - DEX Port only 0 Volts DC	J10 - Vendo Motor Port 15 Volts DC Pins 1 and 12, 24 Volts at Pins 8 and 16, and 13 Volts at Pin 3, 4 and 10
J4 - Display Port 5 Volts DC at Pins 6 and at 3	J11 - Environmental Control Port 24 Volts DC Pins 1,2 and 3
J5 - Option Port 5 Volts DC Pin 1, 2, 3, 4, 7	J13 - Main Power Input 24 Volts AC Pin 3
J6 - Selection Port 5 Volts DC Pins 3, 4, 5, 13, 14	All Power readings were off the J13 Pin 2 ground



## 9.2 WIRING DIAGRAM (CONTINUED)

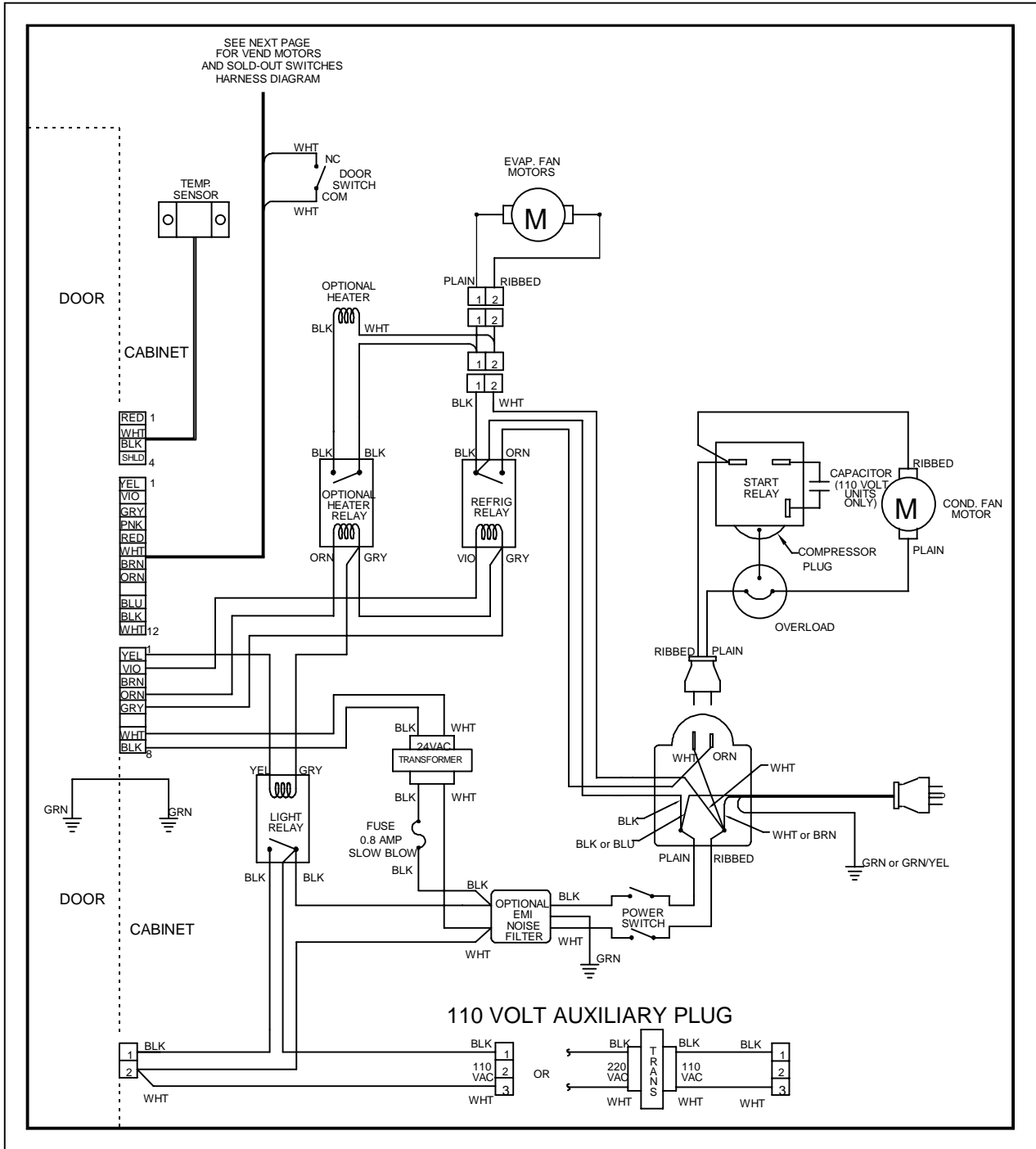



## 9.2 WIRING DIAGRAM (CONTINUED)

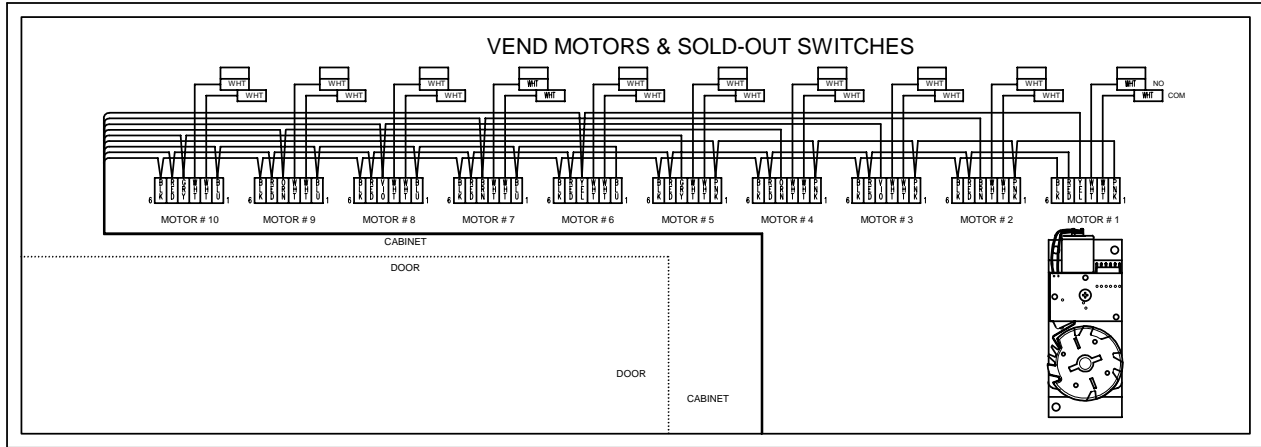

### V-MAX MOTOR HARNESS SCHEMATIC BREAKDOWN

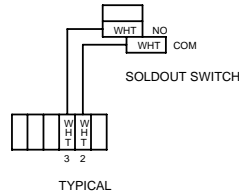

PINS 2&3: 0 VDC SOLDOUT SWITCH TO MOTOR BOARD (EXTENSION OF 2X5 MATRIX)

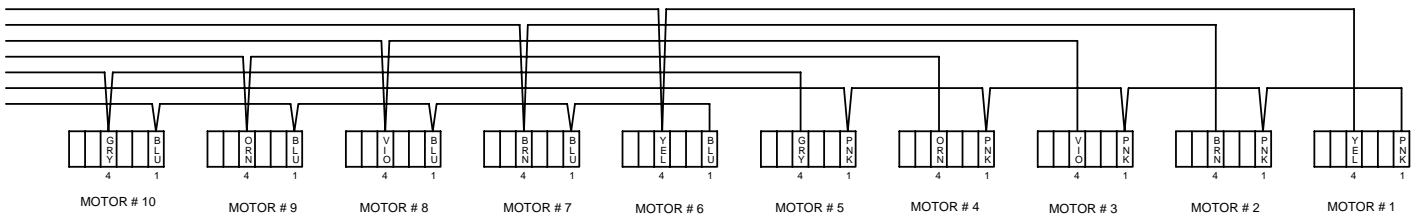

PINS 1&4: 12VDC MOTOR ACTIVATE / SWITCH MONITOR CIRCUIT (2X5 MATRIX)

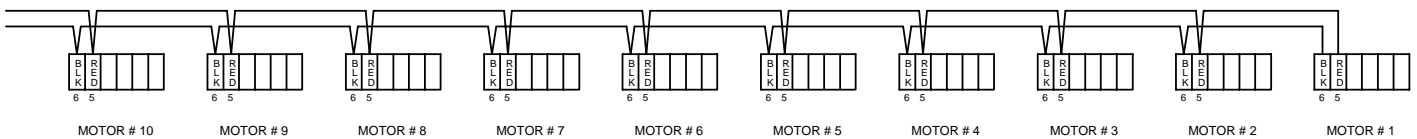

PINS 5&6: 24VDC MOTOR DRIVE CIRCUIT (DAISY CHAIN)



## 9.2 WIRING DIAGRAM (MINI V-MAX)

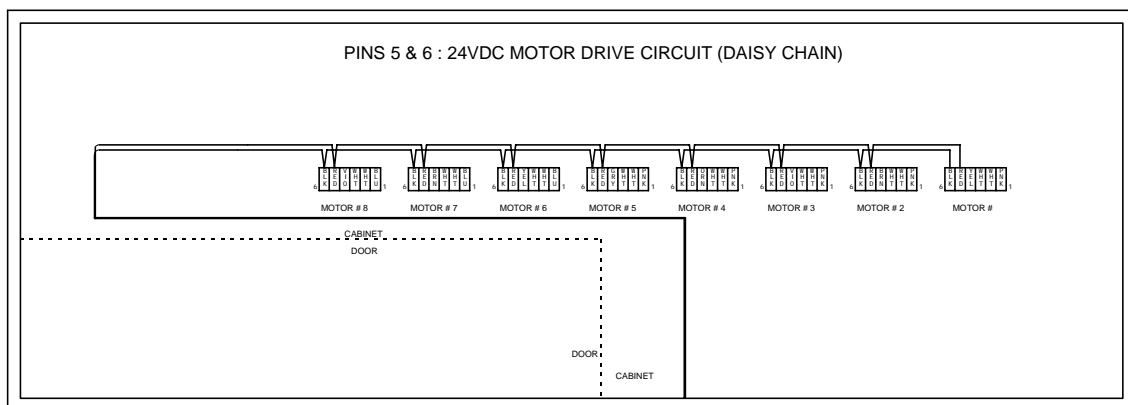
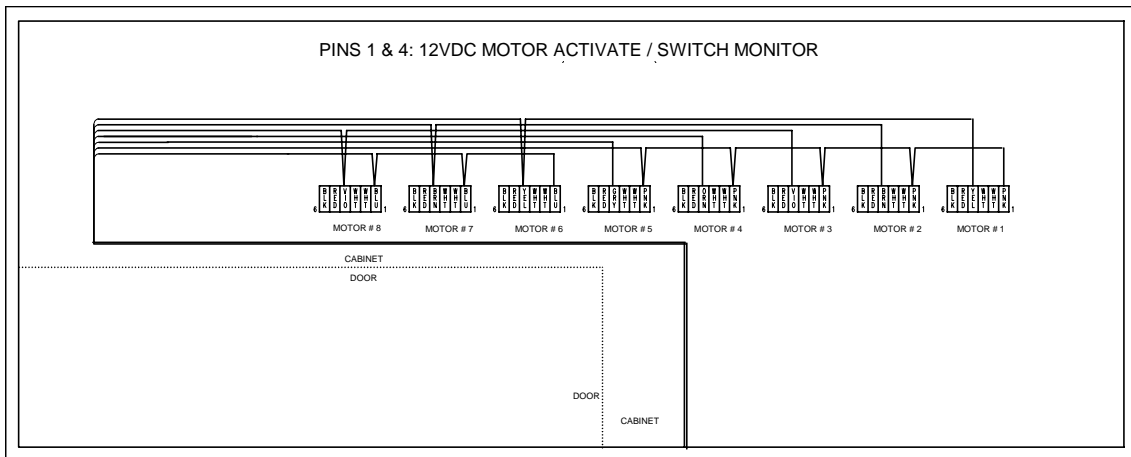
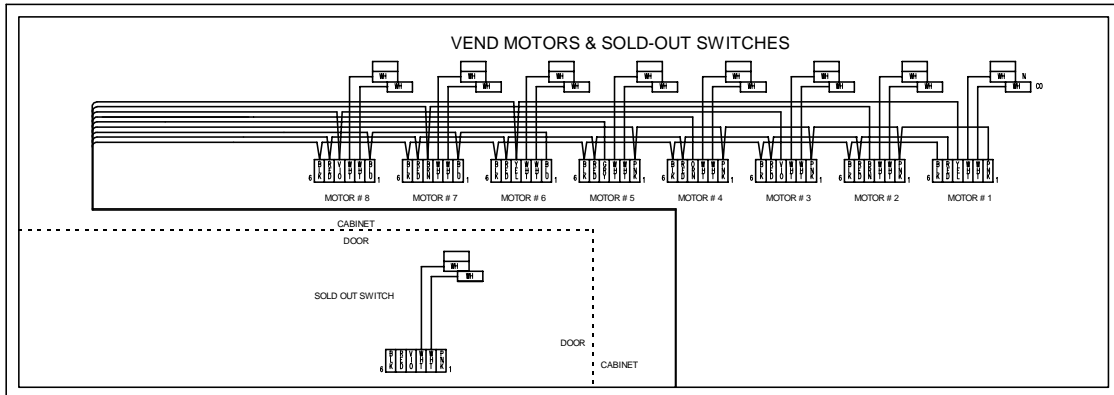



## **NOTES**

- 1. If the outer door is left open for over an hour, the lights and compressor will become active. In order to override this option, press the door switch one time.**



# **V-MAX**

## **VEC 10 PROGRAMMING SECTION**



All programming of the V-Max is done in the service mode as indicated in the following steps below. The main service modes are indicated in white text and the sub-modes are indicated in black text.

**Example:**

**tIne** Time/Date Setting Mode

- YeAr** Year Setting
- nth** Month Setting
- dATe** Date Setting
- Hour** Hour Setting
- Dst** Daylight Saving Time



## FOUR-BUTTON PROGRAMMING

All programming of the V-Max options is done in the service mode. To enter the service mode, open the vendor door and press and release the service mode button that is located on the controller board. (See Figure 1.)

The first four selection buttons are used to navigate through the programming as follows:

Button	Description	Usage
Selection Button 1	Abort	Escape, Cancel
Selection Button 2	Up	Increase, Next
Selection Button 3	Down	Decrease, Previous
Selection Button 4	Enter	OK, Accept, Save

The controller will automatically return to the open door sales mode if:

1. No information from the selection switches is received within approximately five minutes.
2. The service mode button is pressed a second time.
3. The (Abort) button is pressed.
4. The "rtn" function is activated.
5. No information from the selection switch is received within 30 seconds while "rtn" is being displayed.

If the door is closed, the controller will exit the service mode and return to the sales mode. When the programming is entered, any established credit is returned to the customer.



## SET-UP AND CODE DESCRIPTION

### Error

#### Error Display Mode

If (Enter) is pressed at the "Error" prompt, the controller will enter the error display mode. If no errors have occurred, the display will show "nonE". If an error has been detected since the last error reset, the display will show the first error summary code that has occurred.

**EXAMPLE:** "UEnd" would indicate "COLJ" (a column jam error).

If (Enter) is pressed, the controller will display detailed error for the summary code. Pressing (Up and Down) will cycle through any remaining error detail codes. If (Abort) is pressed while displaying any detailed code, the controller will return to the summary code. If (Abort) is pressed while displaying any summary code, the controller will return to the "Error" prompt.

**Note:** See Figure 2 for Error Code Map.

#### Clearing an Error

If (Enter) is pressed and held for two seconds during the display of the detailed error code, that error will be cleared. If other currently accessed detailed errors exist, the next error will now be displayed. If no other errors of this type exist, the next error summary code will now be displayed, or "nonE" if no other errors exist.

### CPO

#### Coin Pay-out Mode

If (Enter) is pressed at the "CPO" prompt, the controller will enter the coin pay-out mode and display the lowest coin value that can be paid out (.5, .10, .25 etc.). The (Up or Down) selection buttons will allow the operator to cycle through the coin tube selections. If (Enter) is pressed, a pay out of the displayed value will be made. Coins will continue to pay out as long as (Enter) is held down. If (Abort) is pressed at any time, the controller will return to the "CPO" prompt.

**EXAMPLE:** If (Enter) is pressed while .05 is displayed, a nickel will be dispensed.

### tuFL

#### Tube Fill Mode

If (Enter) is pressed at the "tuFL" prompt, the controller will enter the coin tube fill mode. In this mode, the operator is allowed to deposit any coin into the coin changer's acceptor when that coin's tube is not full. The tube inventory level will be displayed after each coin is accepted. If (Abort) is pressed at any time during this operation, the controller will return to the start of the "tuFL" prompt.



Error Codes			
Summary level error codes (as displayed)			Error codes are cleared by pressing the ENTER button for 2 sec. when displayed or automatically by the following activities:
Detailed level error codes			
		Description	
nonE		No errors exist	
UEnd		Vend mechanism summary error	
	CJXX	Column jam in column XX	Complete a test cycle for column
Ctrl		Control system summary error	
	dS	Door Switch	Door Closed
	rAn	RAM check sum of service mode settings	Change any service mode setting
	ACLO	AC supply low	
	SF	Scale factor incompatibility	Scale factor corrected
	IS	Machine inlet chute sensor is blocked	Blockage removed
	lb	Machine inlet chute is blocked	Coin detected by changer
SEL		Selection switch summary error	
	SLXX	Selection switch error in switch XX	Switch opens
StS		Space-to-sales summary error	
	UAXX	Unassigned column for column XX	Column is assigned
CHAr		Changer summary error	
	CC	No changer communication	Proper communication
	tS	Tube sensor error	Changer corrected
	IC	Changer inlet chute blocked	A coin is sensed
	tJXX	Tube payout jam in tube XX	Changer corrected
	CrCH	Changer ROM check sum error	Changer corrected
	EE	Excessive escrow attempts	A valid coin is sensed
	nJ	Coin jam	A coin is sensed
	LA	Acceptance rate below 80%	Acceptance rate improves above 80%
	dIS	Disconnected acceptor	Acceptor properly connected
	rouT	Coin routing error	Coin is routed properly
bUAL		Bill validator summary error	
	bC	No bill validator communication	Proper communication
	bFUL	Bill validator stacker full	Receive stacker command
	bILL	Defective bill validator motor	Validator becomes enabled
	bJ	Bill validator jammed	Validator becomes enabled
	brCH	Bill validator ROM check sum error	Validator becomes enabled
	bOPn	Bill validator stacker is open or out of position	Validator becomes enabled
	bS	Bill validator sensor error	Validator becomes enabled
Crdr		Card reader summary error	
	CrC	No card reader communication	Proper communication
	CrXY	Card reader non-transient error: code X, sub-code Y	Error stops being reported
OLn		On-line module summary error	
	OC	No on-line module communication	Proper communication
	OnC	No on-line network communication	Proper communication
	OI	On-line module internal error	Resolved by OLM
rUnd		Remove vend mechanism (USD) summary error	
	rUca	No communication with remote vend mechanism "a"	Proper communication
	rUaX	Error X from remote vend mechanism "a"	Device specific
S-d		Selection/display device (ASD) summary error	
	SdC	No selection/display device communication	Proper communication
	SdX	Error X from selection/display device	Device specific
rFrG		Refrigeration system summary error	
	SEnS	Temperature sensor defective or unplugged	Sensor detected
	COLd	Cabinet temperature 3°F below low limit	Temperature rises above low limit
	Hot	Cabinet temperature 3°F above high limit	Temperature falls below high limit
	CnPr	Cooling system not cooling	System cools 1°F per hour
	Htr	Heating system not heating	System heats 1°F per hour

Figure 2



## SET-UP AND CODE DESCRIPTION (CONTINUED)

### tEst

#### Test Mode

If (Enter) is pressed at the “tEst” prompt, the controller will enter the test mode option. Upon entry into the test mode the display will show the first summary test, “Uend”. Pressing (Up or Down) will cycle through the available tests as listed below. Pressing (Enter) will enter the detailed test mode option. Pressing (Abort) while a summary test prompt is displayed will return the controller to the “tEst” prompt. Pressing (Abort) at the “tEst” prompt has no effect.

TEST OPTIONS	
“Uend”	Test vend motor
“JOG”	Column jog test routine
“SL”	Test selection switch
“SO”	Test sold-out switches
“dSP”	Check display/LED
“rELY”	Check compressor, fan, lights and heater relays

### Uend

#### Test Vend Motor

If (Enter) is pressed at the “tEst” prompt, the “Uend” mode is displayed. If (Enter) is pressed at the “Uend” prompt, the controller will enter the column vend test option. Upon entry into this setting the display will show “CO 1”. This will indicate that a test vend of column 1 may be done. Pressing (Up or Down) will toggle through the available columns. Pressing (Enter) will test vend the displayed column. Pressing (Abort) will return the controller to the “Uend” prompt.

### JOG

#### Column Jog Test Routine

If (Enter) is pressed at the “JOG” prompt, the controller will enter the column jog test routine. Upon entry into this routine the display will show a “CO1” message indicating that a jog test of column 1 may be initiated. Using the (Up or Down) buttons will cycle through the available columns. Pressing the (Enter) button will display a “FOR” message indicating the forward direction. Using the (Up or Down) buttons will toggle between “FOR” (forward) and “rEU” (reverse). Pressing the (Enter) button will initiate a jog test of the last displayed column in the last displayed direction. During the jog test, the direction of travel will remain indicated on the display. The vend motor will be activated and remain activated until the (Enter) button is released. The vend motor will continue in the direction of travel without regard to vend position. Pressing (Abort) will return the controller to the “JOG” prompt.

NOTE: Throughout the entire jog process, the motor will not be allowed to continue to a point or in a direction, that would damage any part of the mechanism.



## SET-UP AND CODE DESCRIPTION (CONTINUED)

**SL**

### Selection Switch Test

If (Enter) is pressed at the “SL” prompt, the controller will enter the selection switch test option. Upon entry into this setting the display will show “SE 4”. This indicates that the fourth button was pressed last. The last selection switch pressed will remain on the display until the service mode timer expires or the (Abort) button is pressed and held for two seconds. This will return the controller to the “SL” prompt.

**SO**

### Sold-out Switch Test

If (Enter) is pressed at the “SO” prompt, the controller will enter the sold-out test option. Upon entry into this setting the display will show “C 10”. This indicates that column 1 is not sold-out. If display shows “C 11” this will indicate that the displayed column is sold-out. Pressing (Up or Down) buttons will toggle through the columns. Pressing (Abort) will return the controller to the “SO” prompt.

**EXAMPLE:** “0” = Column is not Sold-out.  
“1” = Column is Sold-out.

**dSP**

### Check Display/LED

If (Enter) is pressed at the “dSP” prompt, the controller will enter the display test option. Upon entry into this setting the display will toggle through all the vertical and horizontal display elements within each digit. The test will continue until the service mode timer expires or the (Abort) button is pressed. This will return the controller to the “dSP” prompt.

**reLY**

### Check Compressor, Light and Heater Relays

If (Enter) is pressed at the “reLY” prompt, the controller will enter the relay test option. Upon entry into this setting the display will show the state of the first relay, “CnP0”. This means the relay is not activated and ‘1’ means the relay is activated. Pressing (Enter) will toggle the state of the relay. Pressing (Up or Down) will toggle through the available relays as listed below. Pressing (Abort) will return the controller to the “reLY” prompt.

**NOTE:** All relays will be returned to their initial state, “0”, upon the exit of this test routine.

**EXAMPLE:** “0” = Means relay is de-activated.  
“1” = Means relay is activated.

RELAY LIST	
“CnP”	Controls the compressor relay
“Lit”	Controls the sign front light relay
“Htr”	Controls the heater relay ( <i>optional kit</i> )

**Note:** Pressing (Enter) will return you to the “tEst” prompt. Pressing (Up) will get you into “PASS”.



## SET-UP AND CODE DESCRIPTION (CONTINUED)

### **PASS**

#### **Password Protection**

"PASS" will display only if the password has not been entered. The password is entered via the first four selection buttons while the controller is displaying "PASS". The password must be entered within 10 seconds in the following order: 4-2-3-1. The display will go blank after the first selection button is pressed. After completing the sequence, press (Enter). If the password is not recognized, the display will remain blank.

### **CASH**

#### **Cash Counter Display Mode**

If (Enter) is pressed at the "CASH" prompt, the controller will enter the non-resettable cash counter mode by displaying "CASH". Pressing (Enter) will display cash total over the control board's life. A decimal will be displayed in the appropriate position. Pressing (Up or Down) will change the display to "CA N"/"XXXX" where "N" is a selection number and the "XXXX" will be replaced with the current re-settable cash amount. Using the (Up or Down) will cycle through the available selections. If (Abort) is pressed at anytime during this operation, the controller will return to the "CASH" prompt.

### **SALE**

#### **Vend Counter Display Mode**

If (Enter) is pressed at the "SALE" prompt, the controller will enter the non-resettable vend counter display mode by displaying "SALE". Pressing (Enter) will display the number of all paid vends over the control board's life. Using (Up or Down) will cycle through each selection as "SL 1"/"0000." where the "1" indicates the selection and the '0's represent the resettable number of vends for that selection. A decimal will be displayed in the appropriate position. If (Abort) is pressed anytime during this operation, the controller will return to the "SALE" prompt.

### **PrIC**

#### **Selection Price Setting Mode**

If (Enter) is pressed at the "PrIC" prompt, the controller will enter the selection price setting mode. The display will show "Pr 1" if the machine is in multi-price mode, or "SPri" if the machine is in single-price mode.

In the multi-price mode, individual selection prices can be changed using the (Up or Down) to display "PrXX" where 'XX' is the selection number, or choose "ALL" to change the prices for all selection. If (Enter) is pressed, the display will show the current price for the displayed selection. Using (Up or Down) will increase or decrease the price. Holding (Up or Down) for more than five seconds will cause the price to change at 10 times the normal rate. While the desired price is on the display, press (Enter) and it will save that price. Pressing (Abort) will return to the selection level without saving the new price.



## SET-UP AND CODE DESCRIPTION (CONTINUED)

### StS

#### Space-to-Sale Programming Mode

If (Enter) is pressed at the “StS” prompt, the controller will enter the space-to-sales (StS) programming mode by displaying “OPtX” where ‘X’ is the current option selected. Using (Up or Down) will allow the operator to cycle through the available space-to-sales options “Opt1”- “Opt9” and “CSTS”. When one of the options, “Opt1”-“Opt9”, is on the display, pressing (Enter) will select that space-to-sale option and return to the “STS” prompt. If one of the “Opt1”-“Opt9”option is displayed and (Abort) is pressed, the user will return to the “STS” prompt without changing any settings. **NOTE: “Opt1”, “Opt2”, “Opt8”, “Opt9” are the only configuration settings recommended. Factory setting is “Opt1”.**

**For proper configuration settings refer to the label located on the inner door shear panel. (See figure 3)**

PRE- PROGRAMMED SPACE - TO - SALES									
SEL #	COLUMNS								
1	1,2	1,2	1,2	1,2	1,2,3	1,2,3	1,2	1,2,3	ALL
2	3	1,2	1,2	1,2	1,2,3	1,2,3	3,4	1,2,3	ALL
3	4	3,4	3	1,2	1,2,3	1,2,3	5	4,5	ALL
4	5	5	3	1,2	1,2,3	1,2,3	6	6	ALL
5	6	6	4	3	4	4,5	7	7	ALL
6	7	7	4	4	4	4,5	8	8	ALL
7	8	8	5	5	5	6	9	9	ALL
8	9	9	6	6	6	6	10	10	ALL
9	10	10	7	7	7	7	1,2	1,2,3	ALL
10	~	~	8	8	8	8	~	~	ALL
11	~	~	9	9	9	9	~	~	ALL
12	~	~	10	10	10	10	~	~	ALL
13	~	~	1,2	1,2	1,2,3	1,2,3	~	~	ALL
OPTION	1	2	3	4	5	6	7	8	9

Figure 3

### CStS

#### Custom Space-to-Sales Mode

If (Enter) is pressed at the “CStS” prompt, the controller will enter the custom space-to-sales (CStS) programming mode by displaying “SLXX” where ‘XX’ is the current selection for that certain button, alternating with either “nonE” indicating that no columns are assigned to the displayed selection button or the display will scroll through a sequence of numbers that represents the columns that are currently assigned to the selection button. Using (Up or Down) will cycle through all the available selections and then “SAUE”. Pressing (Abort) will go immediately to the “SAUE” prompt, when pressing the (Abort) button will return the controller to the “CSTS” prompt without changing any settings.



## SET-UP AND CODE DESCRIPTION (CONTINUED)

Pressing (Enter) while “SAUE” is displayed will save all changes and return the controller to the “STS” prompt.

Pressing (Enter) while the “SLXX” prompt is displayed will allow columns to be assigned to the current selection. The display will show “Cnn” where “nn” is a column number. Using (Up or Down) will cycle through all the available columns. Pressing (Enter) at any column will enter the edit mode. The display will show “CnnX” where “X” will either be flashing “0”(disabled) or “1”(enabled) to assign the columns(“nn”) to the current selection. Using (Up or Down) will change the assignment status of the columns. Pressing (Abort) will return the controller to the “Cnn” prompt without changing the status of the column, while pressing (Enter) saves the displayed status of the column before returning to the “Cnn” prompt. Pressing (Abort) at the “CnnX” prompt returns the controller to the “SLXX” prompt.

**EXAMPLE:** “Cnn0” = The selection is disabled.

“Cnn1” = The selection is enabled.

### Con

#### Machine Configuration Mode

If (Enter) is pressed at the “Con” prompt, the controller will enter the machine configuration mode by displaying “C1 X” which indicates configuration options number 1 and the “X” is the current status of that setting. If “X” is 1 then status is active, if “X” is “0” then the status is not active. If (Abort) is pressed while at the “C1 X” prompt the controller will return to the “Con” prompt. Pressing (Up or Down) will toggle through the available configuration options. Pressing (Enter) saves the status of the current option and returns the user to the “Con” prompt. Pressing (Abort) returns the controller to the “Con” prompt without saving. (See Figure 4.)

**EXAMPLE:** “0” = The Con is disabled.

“1” = The Con is enabled.

### C1

#### Single/Multi-Price Mode

Toggles between the single-price and multi-price modes. In the single-price mode, the price of selection 1 will be used for all selections. In the multi-price mode, each selection can be set to a different price.

“0” = Single pricing is used.

“1” = Multi-pricing is used.



## SET-UP AND CODE DESCRIPTION (CONTINUED)

CONFIGURATION SETTINGS		
CON#	DESCRIPTION	SETTINGS
C1	PRICE SETTING	0=SINGLE PRICE 1=MULTI PRICE
C2	OPTIONAL FEATURES	0=DISABLE OPTIONAL PROGRAM 1=ENABLE OPTIONAL PROGRAM
C3	POS MESSAGE	0=DISPLAY POS MESSAGE 1=TURN OFF POS MESSAGE
C4	DOOR OPEN MIS	0=DISPLAY SUMMARY ERROR CODES 1=DISPLAY SUMMARY SALES DATA
C5	MIS RESET	0=RESET MIS VIA DEX COMMAND ONLY 1=RESET MIS WHEN DOOR IS CLOSED
C6	RESERVED	
C7	SAVE CREDIT	0=SAVE CREDIT FOR 5 MINUTES 1=SAVE CREDIT INDEFINITELY
C8	FORCE VEND	0=NORMAL VEND 1=FORCE VEND
C9	MULTI VEND	0=SINGLE VEND 1=MULTI VEND
C10	BILL ESCROW	0=ENABLE BILL ESCROW 1=DISABLE BILL ESCROW

Figure 4

**C2**

### Optional Feature Enable

This selection will allow optional features to be enabled and displayed in the current service mode menu. If any of the optional features described in this document are implemented, they must be able to be hidden by this selection. These features currently include "bLC1", "bLC2", "dISC" and "OUeR".

"0" = Option is Off.

"1" = Option is On.



## SET-UP AND CODE DESCRIPTION (CONTINUED)

**C3**

### LED Display Message Mode

Toggles between the LED display modes. In the display/LED mode, the current price will be displayed if in the single price mode. **Note:** *ICE COLD COCA COLA will scroll when the option is set at "0".*

"0" = Display message is On.

"1" = Display message is Off.

**C4**

### Door Open MIS Mode

This option changes the Open-Door Mode Display. If enabled, the total machine sales and total machine cash value are displayed before the error codes. These values represent the number of all paid vends and the cash amount of all paid vends, respectively. The sales and cash value are displayed the same as in the "SALE" and "CASH" service mode functions. The display shows "SALE"/"0000"/"0000" for two seconds on the display/LED, then "CASH"/"0000"/"00.00", then "Error" or "nonE". If this option is disabled, existing errors are displayed, or "nonE" for no existing errors.

"0" = Existing errors or "nonE" is displayed.

"1" = "SALE"/"0000"/"0000"

"CASH"/"0000"/"00.00" and "Error" or "nonE".

**C5**

### MIS Reset Mode

This option is used to allow the door switch to reset all re-settable MIS. It will be reset only if the "CASH" and "SALES" mode were entered.

"0" = All re-settable MIS registers will be reset only when the "CF" command is received from the HHC.

"1" = All re-settable MIS registers are reset when the door switch is activated if any of the re-settable MIS registers are read.

**C6**

### RESERVED FOR FUTURE PROGRAMMING.



## SET-UP AND CODE DESCRIPTION (CONTINUED)

**C7**

### Save Credit Mode

This option is used to determine how long credit should be maintained on the display and available to the customer. If "Save Credit" is enabled it will register the credit for no more than five minutes, after the vend is aborted and returns to standby.

"0" = Clears credit in five minutes.

"1" = Credit remains.

**C8**

### Force Vend

Prevents the machine from making change without a selection being attempted. When this mode is enabled, escrow of coins is allowed until any of the following:

- A. Any bill is inserted into the bill acceptor;
- B. Any "cash box" coin (a coin that is not assigned to a tube) is inserted, or;
- C. The maximum vend price is reached. Once any of these conditions are met, an escrow request is ignored and a vend must be made.

If a selection is made that is sold-out or locked out, this option will be overridden and an escrow request will be honored.

**NOTE:** *Force vend has no effect on the card reader. Once a card is inserted, it can always be returned to the customer via an escrow or the return switch on the card reader.*

"0" = Force-vend is disabled.

"1" = Force-vend is enabled.

**C9**

### Multi-Vend

Allows multiple purchases without re-entering coins. If enabled, instead of returning the change after a vend, the credit will remain on the display to be used for another selection. An escrow will be honored at any time. This option will take precedence over the force-vend option after the first vend has been completed.

"0" = Multi-vend is disabled.

"1" = Multi-vend is enabled.

**C 10**

### Bill Escrow Mode

Allows the escrow of bills. If enabled and the bill value inserted takes the accumulated credit over the maximum price, the bill will be held in the escrow position. If the rule is disabled, bills will always go to the stacker.

"0" = Bill escrow is disabled.

"1" = Bill escrow is enabled.



## SET-UP AND CODE DESCRIPTION (CONTINUED)

### **CCOC**

#### **Correct Change Only Control**

Allows the customer to disable or enable the overpay routine.

If “Con0”, Consumer overpay routine disabled for USA.

If “Con1”, Can be enabled for International use.

If “CCU”, “Correct Change Value” is the value that the controller has the ability to control the “Use Correct Change Only” option.

If “ACC”, “Unconditional Acceptance Value” is the largest value of any single form of currency that can be accepted without knowledge that the equivalent value of coins can be returned. This option applies to coins or bills.

### **PrEU**

#### **Preview Vend Password Setting Mode**

If (Enter) is pressed at the “PrEV” prompt, the controller will display the current password for the preview vend mode. The first digit of the number will be flashing. Pressing (Up or Down) will adjust the currently flashing digit up or down. Pressing (Enter) will save the currently flashing digit and the next digit of the password will begin flashing. All digits may be modified in this manner. Pressing (Enter) while the last digit is flashing saves the currently displayed password and return to the “PrEV” prompt. Pressing (Abort) at any time in the procedure returns to the “PrEV” prompt without saving.

### **LANg**

#### **Change Language**

If (Enter) is pressed at the “LANg” prompt, the controller will display the current language for the preview mode. Pressing (Up or Down) will toggle through the available languages listed below. Pressing (Enter) will activate the displayed language and return to the “LANg” prompt. Pressing (Abort) at any time in the procedure returns to the controller to the “LANg” prompt without changing the active language.

<b>LANGUAGE LIST</b>	
“EnG”	English - mandatory if supported
“Frn”	French - mandatory if supported
“Ger”	German - mandatory if supported
“ItA”	Italian - mandatory if supported
“Port”	Portuguese - mandatory if supported
“ESP”	Spanish - mandatory if supported
“SLO”	Slovene - mandatory if supported



## SET-UP AND CODE DESCRIPTION (CONTINUED)

**tlne**

### Time/Date Setting Mode

If (Enter) is pressed at the “tlne” (time) prompt, the controller will enter the time/date setting mode and display “Enb0” (disable) or “Enb1” (enable). Using (Up or Down) will allow the controller to cycle through all available time selection options. If (Abort) is pressed anytime during this operation, the controller will return to the “tlne” prompt.

TIME SELECTION OPTIONS	
“Enb1”	Enable/Disable time (Edit mode 0/1)
“YEAr”	Current Year (Example '98)
“dAtE”	Current Date (month, day)
“nth”	Current Month
“hour”	Current Time (hours, minutes)
“dSt”	Daylight Saving Time

**YeAr**

### Year Setting Option

If (Enter) is pressed at the “YEAr” prompt, the last two digits of the year are displayed and will be flashing. Pressing (Up or Down) will increase or decrease the year setting. Pressing (Enter) will save the displayed year setting and return the user to “YEAr”. Pressing (Abort) will return to “YEAr” without saving.

**nth**

### Month Setting Option

If (Enter) is pressed at the “nth” prompt, the controller will enter the month setting option. Upon entry into this option the display will show the current two-digit month setting, indicating the month of the year (example: 01-12). Pressing (Up or Down) will increase or decrease the month setting. Pressing (Enter) will save the displayed month setting and return the Controller to the “nth” prompt. Pressing (Abort) while the month digits are flashing returns to the “nth” prompt without saving the month.

**dAtE**

### Date Setting Option

If (Enter) is pressed at the “dAtE” prompt, the current two-digit date (days of the month) is displayed. Pressing (Up or Down) will increase or decrease the date setting. Pressing (Enter) will save the displayed date and return the user to the “datE” prompt. Pressing (Abort) while the date digits are flashing returns to the “datE” prompt without saving the new date.



## SET-UP AND CODE DESCRIPTION (CONTINUED)

### Hour

#### Hour Setting Option

If (Enter) is pressed at the “Hour” prompt, the current time is displayed in a 24-hour format. The left two digits of the display show the hour and the right two digits show the current minutes. While the hour digits are flashing, pressing (Up or Down) will increase/decrease the hour. Pressing (Enter) at this point will save the displayed hours and minutes and the digits will start to flash. While the minute digits are flashing, pressing (Up or Down) will increase/decrease the minutes. Pressing (Enter) at the point will save the displayed hours and minutes and return to the “Hour” prompt. Pressing (Abort) while the hour or minute digits are flashing returns to “Hour” without saving the hour or minutes.

### Dst

#### Daylight Saving Time

If (Enter) is pressed at the “Dst” prompt, the current daylight saving time option will be displayed. Using (Up or Down) will toggle the different countries; AUS (Australian rules), EU (European rules), OFF (No daylight savings) and NA (North American rules). If (Enter) is pressed at this point, the current display option will be saved and the user will be returned to the “DSt” prompt. Pressing (Abort) returns to the “DSt” prompt without saving.

### Lit

#### Light Control

If (Enter) is pressed at the “Lit” prompt the controller will enter the light control programming mode by displaying “Enb0”(disable) or “Enb1” (enable). Using (Up or Down) will allow the operator to cycle through all available time selection options. If (Abort) is pressed anytime during this operation, the controller will return to the code level.

LIGHT CONTROL OPTIONS	
“Enb1”	Enable/Disable light timer (Edit mode 0/1)
“Strt”	Set start time
“dAY”	Set days to time
“Hour”	Set time to start (24 hours)
“StoP”	Set stop time

### EnbX

#### Set Enable/Disable

If (Enter) is pressed at the “Enbx” prompt, the last digit of the prompt will start flashing. Pressing (Up or Down) will toggle from “1” (Enable) to “0” (Disable). Pressing (Enter) will save the displayed setting and return the user to “EnbX”. Pressing (Abort) will return to “EnbX” without saving.

“0” = Setting is disabled.

“1” = Setting is enabled.



## SET-UP AND CODE DESCRIPTION (CONTINUED)

**Strt**

### Start Time Setting

If (Enter) is pressed at the “Strt” prompt, the controller will enter the start time setting option. Upon entry into this option the display will show “dAY”. Pressing (Up or Down) will cycle through the available summary level codes. Pressing (Enter) will enter the detail level option. Pressing (Abort) while a summary level prompt is displayed will return the controller to the “Strt” prompt. Pressing (Abort) at the “Strt” prompt will return the controller to the “Lit” prompt.

**dAY**

### Day Setting Option

If (Enter) is pressed at the “dAY” prompt, the current day of the week is displayed. The days are displayed as follows:

“nonX”	Monday
“tuEX”	Tuesday
“WE dX”	Wednesday
“thuX”	Thursday
“FriX”	Friday
“SA tX”	Saturday
“SunX”	Sunday
“ALL”	All Days

“0” = Setting is disabled.

“1” = Setting is enabled.

Pressing (Up or Down) at this point will rotate through the days of the week. Pressing (Enter) when a day (e.g. nonX) is displayed the “X” will start to flash by pressing (Up or Down) will toggle from “0” (disable) to “1” (enable). If (Enter) is pressed, the displayed day is saved and the user is returned to “dAY” prompt. Pressing (Abort) returns the controller to “dAY” prompt without saving.

**Hour**

### Start Hour Setting

If (Enter) is pressed at the “Hour” prompt, the current time is displayed in a 24-hour format. The left two digits of the display will show the hour and the right two digits show the current minutes. While the hour digits are flashing, pressing (Up or Down) will increase/decrease the hour. Pressing (Enter) at this point will save the displayed hours and minutes and the digits will start to flash. While the minute digits are flashing, press (Up or Down) to increase/decrease the minutes. Pressing (Enter) at this point will save the displayed hours and minutes and return to the “Hour” Prompt. Pressing (Abort) while the hour or minutes digits are flashing returns to “Hour” without saving.



## SET-UP AND CODE DESCRIPTION (CONTINUED)

### StoP

#### Set Stop

If (Enter) is pressed at the “StoP” prompt, the controller will enter the stop time setting option. Upon entry into this option the display will show “dAtE”. Pressing (Up or Down) will cycle through the available summary level codes. Pressing (Enter) will enter the detail level option. Pressing (Abort) while a summary level prompt is displayed will return the controller to the “StoP” prompt. Pressing (Abort) at the “StoP” prompt will return the controller to the “Lit” prompt. **Note: To program days and hours refer to page CP-15.**

### rFrG

#### Refrigeration Control Mode

If (Enter) is pressed at the “rFrG” prompt, the controller will enter the refrigeration control option by displaying “EnbX” indicating the enable/disable setting mode. Using (Up or Down) will allow the operator to toggle between the following modes:

REFRIGERATION CONTROL OPTIONS	
“EnbX”	Enable/Disable Refrigeration timer (Edit mode 0/1)
“Strt”	Set start time
“dAY”	Set days to time
“Hour”	Set time to start (24 hours)
“StoP”	Set stop time
“dAY”	Set days to time
“Hour”	Set time to start (24 hours)

#### Temperature Setting

If (Enter) is pressed at the “rFrG” prompt, the controller will enter the refrigeration control option by displaying “EnbX” indicating the enable/disable setting mode. Using (Up or Down) will allow the operator to toggle between the following modes:

TEMPERATURE SETTING OPTIONS	
“dEGX”	Set Temperature (Edit mode Fahrenheit/Celsius)
“SEtP”	Temperature set point (Factory setting 35°F 1.5°C)
“Stor”	Storage temperature setting (Factory setting 60° F 15.5°C)
“dSP0”	POS temperature display (Edit mode 0/1)

### dEGX

#### Degree Setting

If (Enter) is pressed at the “dEGX” prompt, the controller will display “dEGX” where ‘X’ will be ‘F’ if the controller is currently in °F (Fahrenheit) mode or ‘C’ if the controller is currently in °C (Celsius) mode. Pressing (Up or Down) while the “X” digit is flashing will toggle the ‘X’ digit between ‘F’ and ‘C’. Pressing (Enter) will save the displayed temperature mode and return the user to the “dEGX” prompt. Pressing (Abort) will return to the “dEGX” prompt without saving.



## SET-UP AND CODE DESCRIPTION (CONTINUED)

### SEtP

#### Set Point Setting (35°F)

If (Enter) is pressed at the "SEtP" prompt, the controller will display "XX.Xt" where 'X' will be the current set point temperature. Pressing (Up or Down) will increase/decrease by one degree increments. Pressing (Enter) will save the displayed temperature setting and return the user to the "SEtP" prompt. Pressing (Abort) will return to the "SEtP" prompt without saving.

### Stor

#### Storage Temperature Setting (60°F)

If (Enter) is pressed at the "Stor" prompt, the controller will display "XX.Xt" where 'X' will be the current storage temperature. Pressing (Up or Down) will increase/decrease by one degree increments. Pressing (Enter) will save the displayed storage temperature setting and return the user to the "Stor" prompt. Pressing (Abort) will return to the "Stor" prompt without saving.

### dSP0

#### Display Temperature

If (Enter) is pressed at the "dSP0" prompt, the controller will enter into the LED temperature display enable option. Upon entry into this option the display will show the current setting "dSP0" where the "0" is flashing will disable the temperature from being shown in the LED or if "1" is flashing the temperature will be displayed in the LED following "ICE COLD COCA COLA". Pressing (Up or Down) will toggle the digit between '0' and '1'. Pressing (Enter) will save the currently displayed setting and return the user to the "dSP0" prompt. Pressing (Abort) will return to the "dSP0" prompt without saving.

### BLC 1

#### Block Selection Setting

If (Enter) is pressed at the "bLC1" or "bLC2" prompt, the controller will enter the second bank of selection blocking control option. Upon entry into this routine the display will show the first summary level code "Enb0". Pressing (Enter) will save the currently displayed setting and return the user to the "bLC1" prompt. Pressing (Abort) will return to the "bLC1" prompt without saving.

Using (Up or Down) will let the operator toggle between the following modes:

**Note: "BLC1" will not be accessible when "C2" is set at "0".**

"0" = Block option is disabled.

"1" = Block option is enabled.



## SET-UP AND CODE DESCRIPTION (CONTINUED)

BLOCK SELECTION OPTIONS	
"EnbX"	Enable/Disable selection blocking (Edit mode 0/1)
"Strt"	Set start time
"dAY"	Set days to time
"Hour"	Set time to start (24 hours)
"StoP"	Set stop time
"dAY"	Set days to time
"Hour"	Set time to start (24 hours)
"SEL"	Set selection time

### dISC

#### Discount Setting Mode

If (Enter) is pressed at the "dISC" prompt, the controller will enter the discount control setting blocking control routine. Upon entry into this setting the display will show the first summary level code "Enb0". If (Up or Down) is pressed it will cycle through the available summary level codes as listed below. Pressing (Enter) will save the currently displayed setting and return the user to the "dISC" prompt. Pressing (Abort) will return to the "dISC" prompt without saving.

Using (Up or Down) will let the operator toggle between the following modes:

**Note: "dISC" will not be accessible when "C2" is set at "0".**

"0" = Disabled discount setting.

"1" = Enabled discount setting.

DISCOUNT SETTING OPTIONS	
"EnbX"	Enable/Disable discount setting (Edit mode 0/1)
"Strt"	Set start time
"Day"	Set days to time
"Hour"	Set time to start (24 hours)
"StoP"	Set stop time
"Day"	Set days to time
"Hour"	Set time to start (24 hours)
"SEL"	Set selection time
"LESS"	Set Discount amount



## SET-UP AND CODE DESCRIPTION (CONTINUED)

### SEL

#### Selection Setting

If (Enter) is pressed at the “SEL” prompt, the controller will enter the selection setting option. Upon entry into this setting the display will show the current setting for selection as “01 1”, where “1” shows it is enabled or “0” if the option is disabled. If (Up or Down) is pressed it will cycle through the valid selections or “ALL”. Pressing (Enter) will save the currently displayed setting and return the controller to the “SEL” prompt. Pressing (Abort) will return the controller to the “SEL” prompt without saving.

“0” = Selection setting is disabled.

“1” = Selection setting is enabled.

### LESS

#### Selection Setting

If (Enter) is pressed at the “LESS” prompt, the controller will enter the discount amount option. Upon entry into this setting the display will show the current four digit discount amount. If (Up or Down) is pressed it will increase or decrease the lowest discount amount. Pressing (Enter) will save the currently displayed setting and return the user to the “LESS” prompt. Pressing (Abort) will return to the “LESS” prompt without saving.

### OUEr

#### Over-Ride Option Mode (Units equipped with optional key switch)

If (Enter) is pressed at the “OUEr” prompt, the controller will enter the over-ride option. Upon entry into this setting the display will show the first summary level code “FrEX”. If (Up or Down) is pressed it will cycle through the available summary level codes as listed below. Pressing (Enter) will save the currently displayed setting and return the user to the “OUEr” prompt. Pressing (Abort) will return to the “OUEr” prompt without saving.

Using (Up or Down) will let the operator toggle between the following modes:

“0” = Disabled over-ride option.

“1” = Enabled over-ride option.

**Note: “OUEr” will not be accessible when “C2” is set at “0”.**

OVERRIDE SETTING OPTIONS	
“FrE0”	Enable/Disable free vend (Edit mode 0/1)
“Und0”	Enable/Disable No vend
“bLC0”	Selection blocking over-ride
“dSC0”	Discounting over-ride
“Lit0”	Lighting control over-ride
“FrG0”	Refrigeration control over-ride

## SET-UP AND CODE DESCRIPTION (CONTINUED)



## **FrE0**

### **Over-Ride Free Vend**

If (Enter) is pressed at the “FrE0” prompt, the controller will enter the free vend enable option. Upon entry into this setting the display will show the current setting “FrE0”. Pressing (Up or Down) will toggle between ‘0’(disable) or ‘1’(enable). Pressing (Enter) will save the currently displayed setting and return the user to the “FrE0” prompt. Pressing (Abort) will return to the “FrE0” prompt without saving.

“0” = Disabled free vend.

“1” = Enabled free vend.

## **Und0**

### **Over-Ride No Vend**

If (Enter) is pressed at the “Und0” prompt, the controller will enter the no vend (vend over-ride) enable routine. Upon entry into this setting the display will show the current setting “Und0”. Pressing (Up or Down) will toggle between ‘0’ (disable) or ‘1’ (enable). While enabled, selections will not be allowed to vend and a “nO SALE” message will be displayed.

NOTE: If both the “free vend” and “no vend” features are enabled, the “no vend” will be given priority.

## **Blc0**

### **Over-Ride Selection Blocking**

If (Enter) is pressed at the “blc0” prompt, the controller will enter the selection blocking over-ride enable option. Upon entry into this setting the display will show the current setting “blc0”. Pressing (Up or Down) will toggle between ‘0’ (disable) or ‘1’ (enable). Pressing (Enter) will save the currently displayed setting and return the user to the “blc0” prompt. Pressing (Abort) will return to the “blc0” prompt without saving.

“0” = Disabled selection blocking.

“1” = Enabled selection blocking.

## **dSC0**

### **Over-Ride Discount**

If (Enter) is pressed at the “dSC0” prompt, the controller will enter the discounting over-ride enable option. Upon entry into this setting the display will show the current setting “dSC0”. Pressing (Up or Down) will toggle between ‘0’ (disable) or ‘1’ (enable). Pressing (Enter) will save the currently displayed setting and return the user to the “dSC0” prompt. Pressing (Abort) will return to the “dSC0” prompt without saving.

“0” = Disabled discount over-ride.

“1” = Enabled discount over-ride.



## SET-UP AND CODE DESCRIPTION (CONTINUED)

**Lit0**

### Over-Ride Lighting Control

If (Enter) is pressed at the "Lit0" prompt, the controller will enter the lighting control over-ride enable option. Upon entry into this setting the display will show the current setting "Lit0". Pressing (Up or Down) will toggle between '0' (disable) or '1' (enable). Pressing (Enter) will save the currently displayed setting and return the user to the "Lit0" prompt. Pressing (Abort) will return to the "Lit0" prompt without saving.

"0" = Disabled lighting control.

"1" = Enabled lighting control.

**FrGO**

### Over-Ride Refrigeration Control

If (Enter) is pressed at the "FrGO" prompt, the controller will enter the refrigeration control over-ride enable option. Upon entry into this setting the display will show the current setting "FrGO". Pressing (Up or Down) will toggle between '0' (disable) or '1' (enable). Pressing (Enter) will save the currently displayed setting and return the user to the "FrGO" prompt. Pressing (Abort) will return to the "FrGO" prompt without saving.

"0" = Disabled refrigeration control over-ride.

"1" = Enabled refrigeration control over-ride.

**rUnd**

### Remote Vend Mechanism – Reserved for future technology

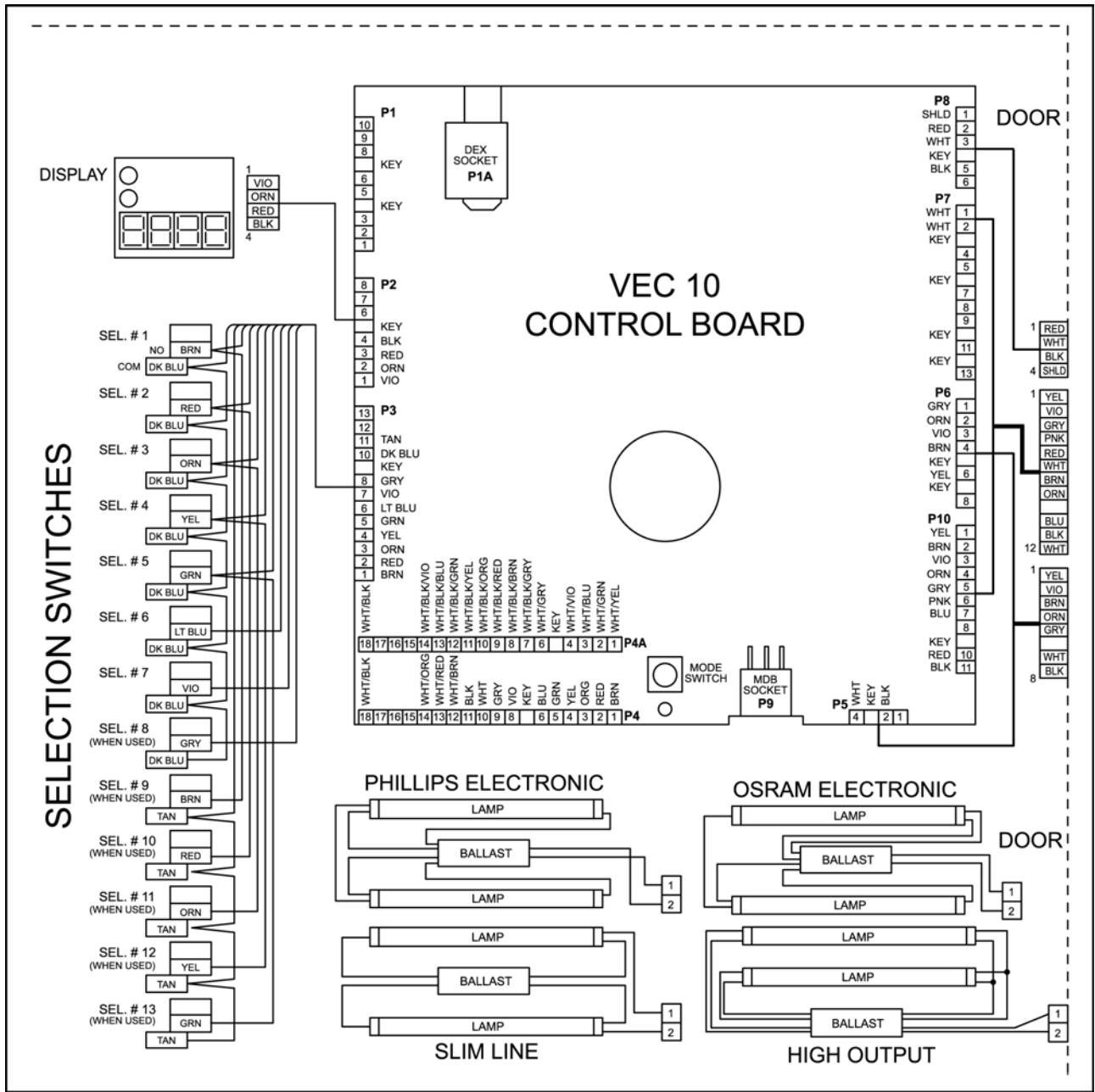

**VEC 10 WIRING DIAGRAM (COCA-COLA)**



# VEC 10 WIRING DIAGRAM (CONTINUED)

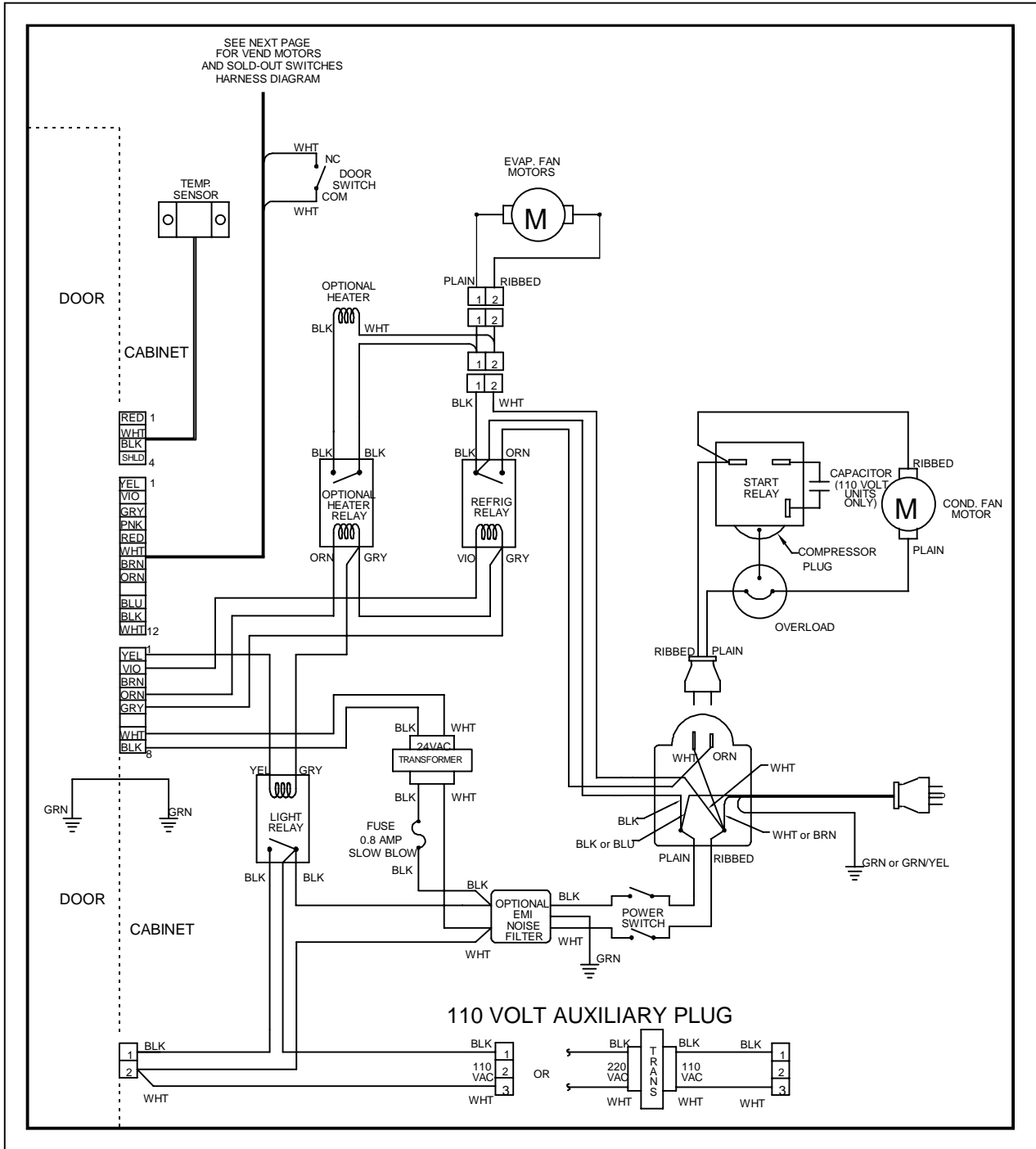



## VEC 10 WIRING DIAGRAM (CONTINUED)

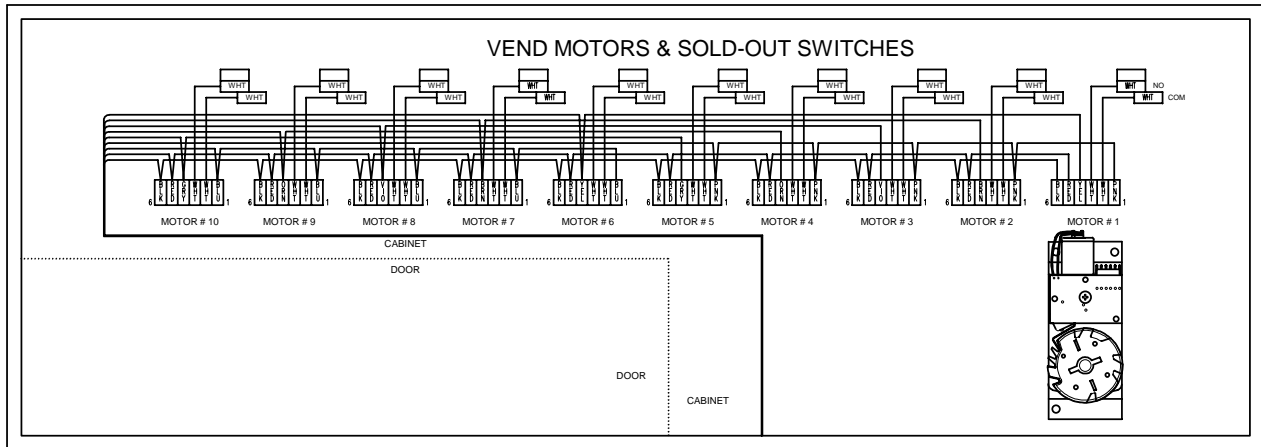

## V-MAX MOTOR HARNESS SCHEMATIC BREAKDOWN

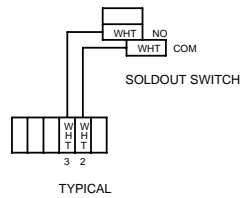

PINS 2&3: 0 VDC SOLDOUT SWITCH TO MOTOR BOARD (EXTENSION OF 2X5 MATRIX)

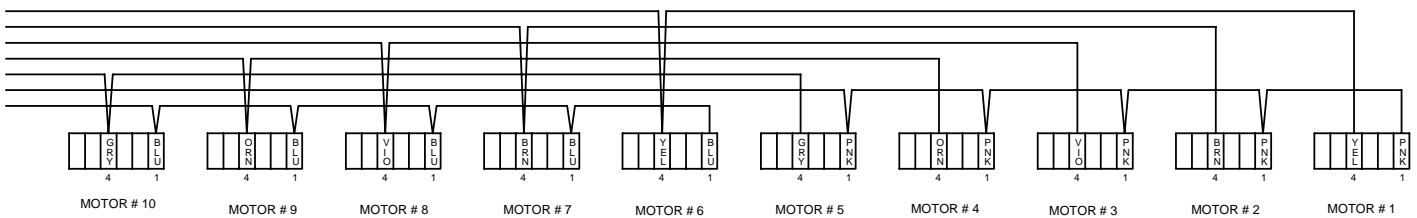

PINS 1&4: 12VDC MOTOR ACTIVATE / SWITCH MONITOR CIRCUIT (2X5 MATRIX)

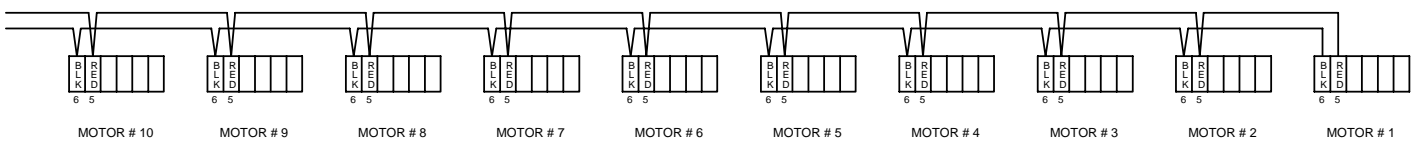

PINS 5&6: 24VDC MOTOR DRIVE CIRCUIT (DAISY CHAIN)



# VEC 10 WIRING DIAGRAM (MINI V-MAX)

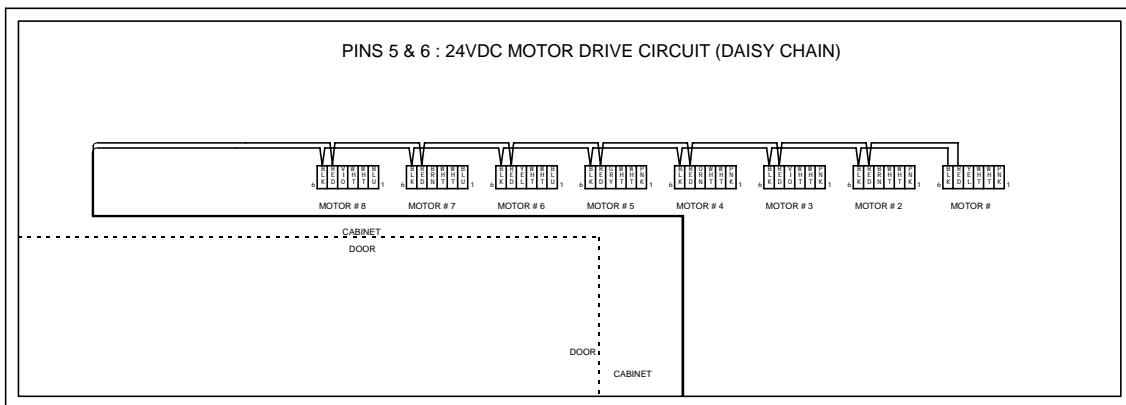
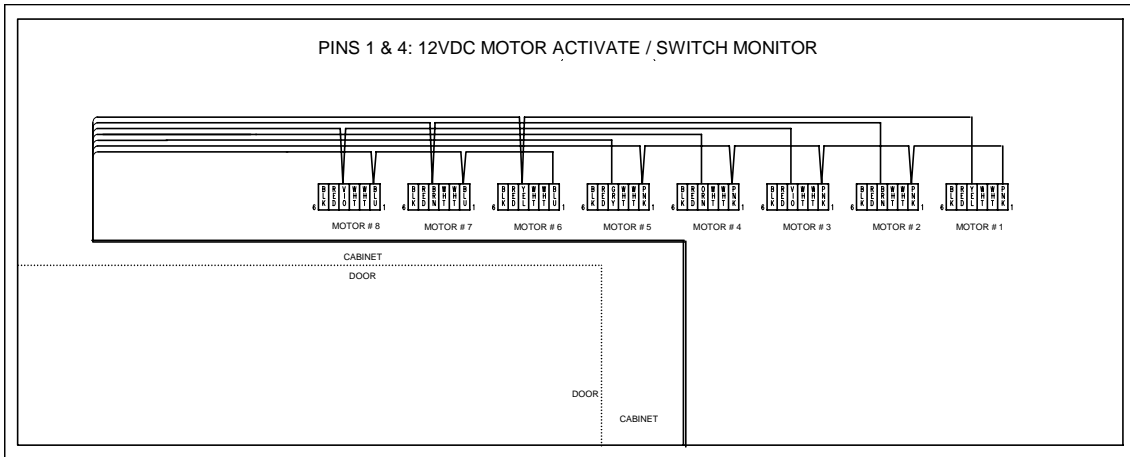
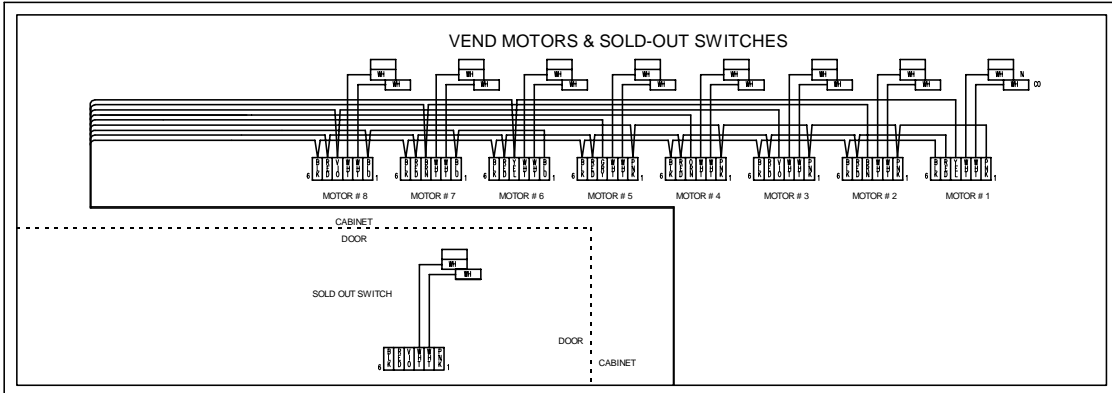



## **NOTES**

- 1. If the outer door is left open for over an hour, the lights and compressor will become active. In order to override this option just press the door switch one time.**



# **V-MAX**

## **CABINET PARTS SECTION**



## READING A PARTS LIST

- I **ITEM NUMBER** is found in two locations:
    - A. It is on the drawing plate, and identifies the part and its location;
    - B. The same number is in the parts lists and ties the two together.
  
  - II **PART NUMBER** is the part number that has been assigned to a specific part by Vendo, for easier identification.
  
  - III **QUANTITY REQUIRED** relates to the amount required of a part, or will be indicated by "A/R" as required to attach it to another part.
  
  - IV **PART NAME AND DESCRIPTION** is the general description for the part, for easier identification when ordering a like part.
  
  - V **HARDWARE** is identified by a letter in a hexagon. Refer to hardware list section for description and part numbers. See pages C-4 and C-5.
- 

The example below will show how the parts are listed in the parts lists:

1. **VEND MOTOR ASSEMBLY:** This is the main assembly name, and any replaceable parts will be indented below the assembly.
  
2. **RETAINER CAM:** This is an individual part, and will be indented. These indented parts can be ordered separately, so you do not need to order the entire assembly.
  
3. Whenever an assembly is ordered, all the parts that are indented will be included in the assembly. Any hardware will be listed next to their corresponding parts.
  
4. Any parts that may be ordered separately will not have any indented parts listed below them.

### **"V-MAX" VEND MOTOR ASSEMBLY**

ITEM NO.	DESCRIPTION	QTY REQ'D	PART NO.
1	VEND MOTOR ASSEMBLY	-	<a href="#">1115821</a>
2	RETAINER CAM	1	<a href="#">1113244</a>
3	TIMING CAM	1	1113236
4			















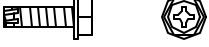

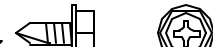
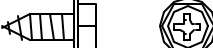
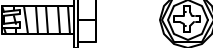

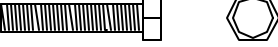
If an asterisk is listed below the parts list, it is an indication that special information is noted. There may be more than one asterisk (\*) (\*\*) (\*\*\*) denoting special notes.



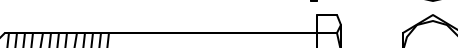

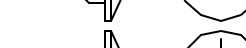























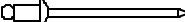









<b>“V-MAX” KIT LIST</b>		
<b>DESCRIPTION</b>	<b>KIT NUMBER</b>	
INNER - OUTER DOOR LOCK	1120520	
S/S SLIDING LOCK POS COVER KIT	1122630	
T-HANDLE LOCK COVER KIT - TRADE	1047795	
T-HANDLE LOCK COVER KIT - COCA-COLA	1047779	
T-HANDLE LOCK COVER KIT - DR PEPPER	1088392	
VENDOR SUPPORT KIT - BLACK BRACKETS	133666	
INNER DOOR GASKET - 72"	1075678	
INNER DOOR GASKET - 79"	1075678-1	
CASTER KIT	133513	
CASTER W/ BRAKE KIT	133513-1	
COIN BOX LOCK	1087759	
HOPPER GUARD (CURVED)	1070538	
HOPPER GUARD (ROBO)	1076082	
<b>UNIQUE FOR V-MAX</b>		
<b>DESCRIPTION</b>	<b>PART NUMBER</b>	<b>QTY REQ</b>
BUCKET	1120146	1
BACK SPACER -72"	1078805	1
BACK SPACER -79"	1078805-1	1
LATCH BRACKET	1079112	1
GAGE BAR	1111651	1
GATE	1121282	1
FLAT SHIM	1078848	A/R
SPACER 0.47	1078872	A/R
SPACER 0.46	1078864	A/R
SPACER 0.37	1122032	A/R
<b>COMMON PARTS V-MAX</b>		
<b>DESCRIPTION</b>	<b>PART NUMBER</b>	<b>QTY REQ</b>
QUICKER LOCK CAP	1111988	1
COINAGE DOOR LATCH	1085546	1
EVAPORATOR FAN MOTOR	42321-17	1
CONDENSER FAN MOTOR	42321-36	1
PRODUCT CLIP (SHORT) - WHITE	1066104	A/R
PRODUCT CLIP (TALL) - BLACK	1066112	A/R
PRODUCT CLIP (MEDIUM) - GRAY	1066112-1	A/R
PRODUCT CLIP (3 <sup>RD</sup> CAN CLIP) - GRAY	1121704	A/R
PRODUCT CLIP (4 <sup>TH</sup> CAN CLIP) - BLACK	1122103	A/R

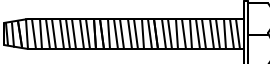

## Hardware List

PART NO.	DESCRIPTION	PICTORIAL
A	V800762 #8 X 5/16" TAPPING SCREW .....	
B	V802139 #8 X 5/8" TAPPING SCREW .....	
C	V800586 #8 X 3/8" TAPPING SCREW W / LOCK WASHER .....	
D	V801493 #8 X 1/2" TAPPING SCREW (FOR PLASTIC) .....	
E	V801475 #8 X 1/2" TAPPING SCREW .....	
F	V801421 #10 X 5/16" TAPPING SCREW .....	
G	V800570 #10 X 3/8" TAPPING SCREW .....	
H	V802047 #10 X 3/8" SCREW .....	
I	V802141 #10 X 1/2" TAPPING SCREW .....	
J	V801422 #10 X 1/2" TAPPING SCREW .....	
K	V801489 #10 X 1/2" SELF DRILLING SCREW .....	
L	V800512 #10 X 1-3/8" TAPPING SCREW .....	
M	V802115 #10 X 1" BOLT .....	
N	V801360 1/4" X 1/2" TAPPING SCREW W / LOCK WASHER .....	
O	V801343 1/4" X 1" TAPPING SCREW .....	
P	V801490 1/4" X 1" SELF DRILLING SCREW .....	
Q	V802053 1/4" X 2-1/4" BOLT .....	
R	V802069 1/4" X 5/8" CARRIAGE BOLT .....	
S	V801434 1/4" X 3/4" CARRIAGE BOLT .....	
T	V800267 1/4" X 3/8" BOLT .....	
U	V800956 #8 NUT W / LOCK WASHER .....	
V	V800952 #10 NUT W / LOCK WASHER .....	

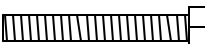

W	V802111	#10 HEX NUT .. .. .		
X	V802113	#10 LOCK NUT W / NYLON INSERT .. .. .		
Y	V800959	1/4" NUT W / LOCK WASHER .. .. .		
Z	387925	1/4" LOCK NUT W / NYLON INSERT .. .. .		
AA	V802062	3/8" LOCK NUT W / NYLON INSERT .. .. .		
AB	V801013	#10 FLAT WASHER . . . . .		
AC	389026	#10 FLAT WASHER, LARGER O.D. . . . .		
AD	V801491	3/8" FLAT WASHER . . . . .		
AE	V801412	1/8" POP RIVET .. .. .		
AF	43842	CLOSED END CONNECTOR .. .. .		
AG	V802166	1/2" 13 X 1-1/2" BOLT .. .. .		
AH	V802165	1/2" LOCK WASHER..... . . . .		
AI	V801023	1/2" FLAT WASHER..... . . . .		
AJ	V801435	1/4" 20 X 1" CARRIAGE BOLT .. .. .		
AK	V329258	1/4" X 20 CARRIAGE BOLT..... . . . .		
AL	V800140	#10 X 3/8" TAPPING SCREW .. .. .		
AM	V802173	1/4" X 1/2" TAPPING SCREW .. .. .		
AN	V802162	1/4" X 1-3/4" SCREW . . . . .		
AO	V802169	1/4" X 1-3/8" BOLT .. .. .		

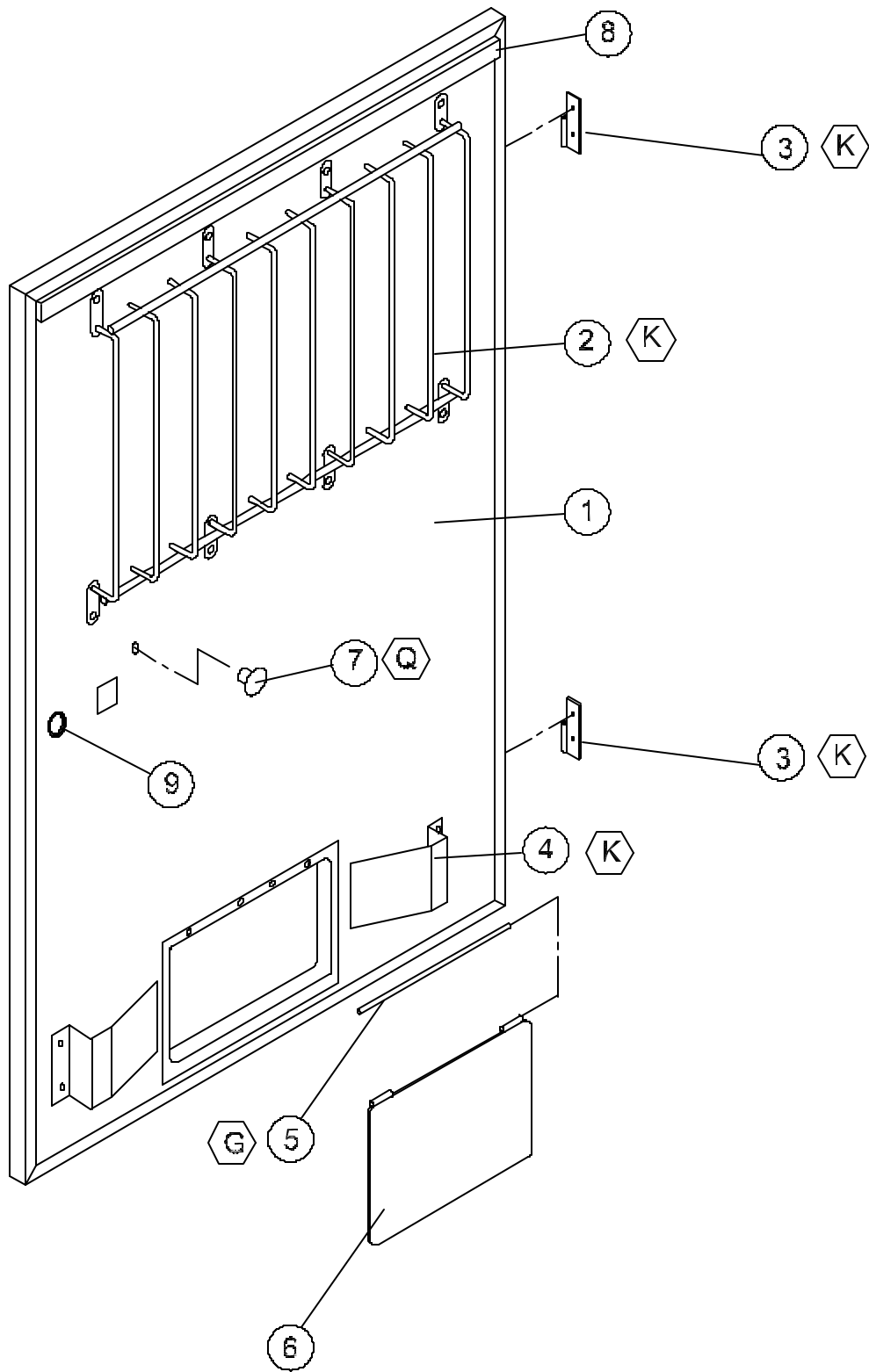



**V-MAX INNER DOOR ASSEMBLY**

ITEM NO.	MODEL NUMBER		GIV	576	720	840
	DESCRIPTION	QTY REQ	PART NO.	PART NO.	PART NO.	PART NO.
1	INNER DOOR ASSEMBLY (FOAMED)	1	134302-54	134302-53	134302-44	134302-47
2	PROD. RETAINER UPPER	1	1120633-4	1117937	1120633-4	1120633-5
3	HINGE - FEMALE	2	<a href="#">1121286</a>	<a href="#">1121286</a>	<a href="#">1121286</a>	<a href="#">1121286</a>
4	PROD. DEFLECTOR	2	<a href="#">1120129</a>	<a href="#">1120129</a>	<a href="#">1120129</a>	<a href="#">1120129</a>
5	PIN - HINGE	1	389985	389985	389985	389985
6	FLAP - DOOR (REVERSIBLE)	1	<a href="#">1013076</a>	<a href="#">1013076</a>	<a href="#">1013076</a>	<a href="#">1013076</a>
7	KNOB - DOOR	1	388305	388305	388305	388305
8	RAIN SEAL - INNER DOOR	1	<a href="#">1111732-2</a>	<a href="#">1111732-2</a>	<a href="#">1111732-2</a>	<a href="#">1111732-2</a>
9	GROMMET	2	<a href="#">388090</a>	<a href="#">388090</a>	<a href="#">388090</a>	<a href="#">388090</a>
<b>THE FOLLOWING ARE NOT SHOWN</b>						
~	LABEL - PRODUCT SET-UP GUIDE	1	1122196	1122196	1122196	1122196
~	LABEL - 9.2 ERROR CODE MAP	1	1111465	1111465	1111465	1111465
~	LABEL - PROGRAMMING VEC 9.2	1	1111244	1111244	1111244	1111244
~	LABEL - WIRING DIAGRAM VEC 9.2	1	1122839	1122839	1122839	1122839
~	LABEL - WARNING	1	1008323-1	1008323-1	1008323-1	1008323-1
~	LABEL - CONFIGURATION MAP	1	1111457	1111457	1111457	1111457
~	LABEL - SPACE TO SALES	1	1123367	1123367	1123367	1123367

1

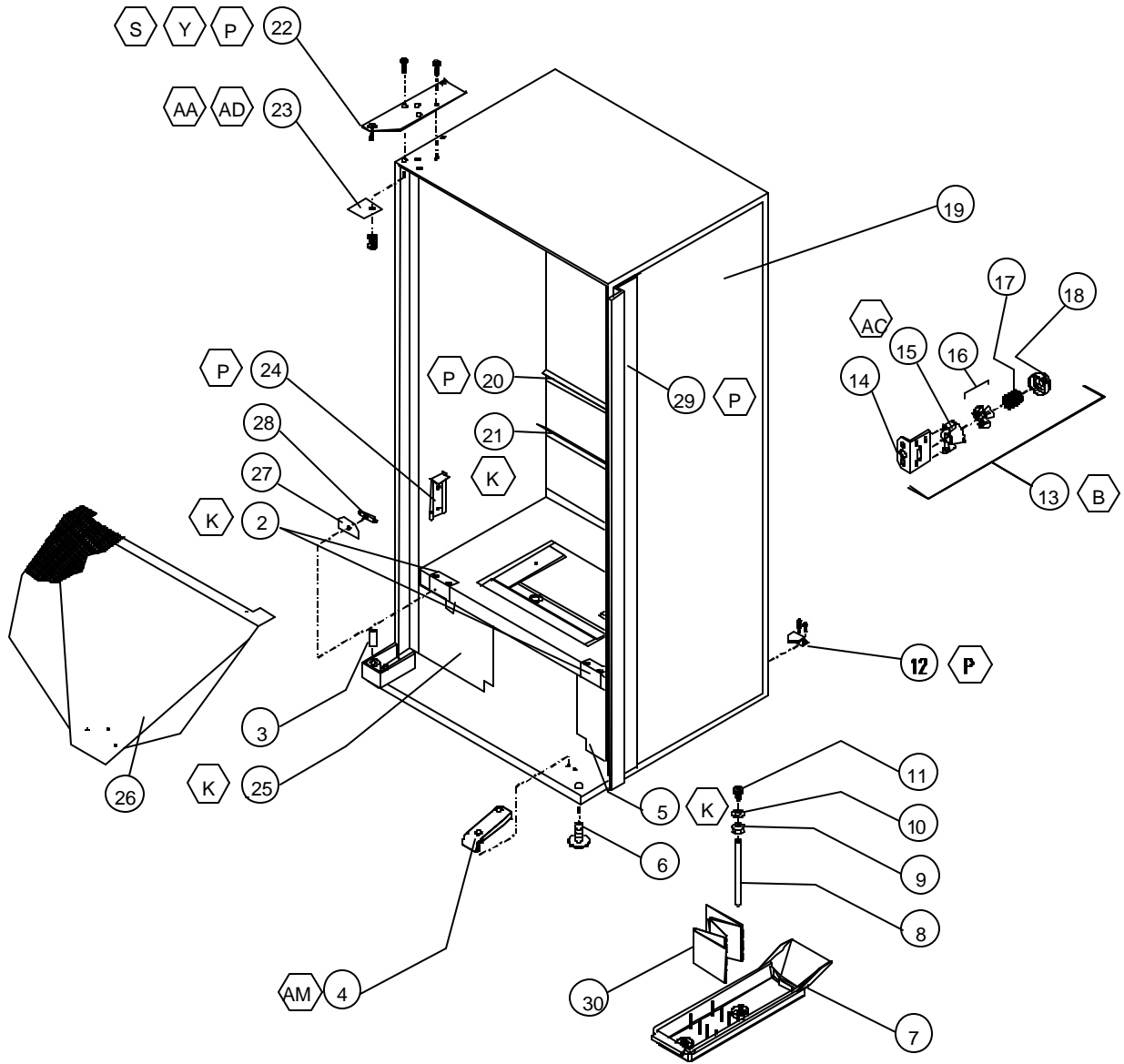



### V-MAX CABINET ASSEMBLY

ITEM NO.	DESCRIPTION	QTY REQ	PART NO.
1	CABINET ASSEMBLY - FOAMED	1	*
2	CLOSURE BRACKET	2	1078791
3	HINGE PIN	1	389071
4	RAMP	1	1120387
5	AIR DAM - RIGHT	1	1122548
6	LEVELING LEG	4	1059902
7	CONDENSATE PAN	1	1122475
8	DRAIN TUBE	1	1088449
9	NUT - DRAIN TUBE	1	387925
10	FOAM WASHER	1	387837
11	DRAIN TUBE FUNNEL	1	1068678
12	BRACKET - REFRIGERATION	2	388387
13	QUICKER LOCK ASSEMBLY	1	2010085-04
14	LATCH BRACKET	1	1079112
15	NUT RETAINER HOUSING	1	389022
16	NUT SEGMENT	3	1001477
17	SPRING	1	389690
18	CAP	1	1111988
19	SIDE DECAL	2	**
20	REAR STACK SUPPORT BRACKET	1	1079015
21	AIR BAFFLE - CABINET	1	1068023
22	TOP HINGE ASSEMBLY	1	2000805-03
23	BACKING PLATE	1	1120667
24	FRONT STACK SUPPORT BRACKET	2	1079007
25	AIR DAM ASSEMBLY (SEE PGS C16-C17)	1	--
26	PRODUCT CHUTE ASSEMBLY	1	1121926
~	PRODUCT CHUTE ASSEMBLY (MODEL 576)	1	1121926-1
27	DOOR SWITCH BRACKET	1	1121043
28	DOOR SWITCH	1	323007
29	OVERLAPPING DOOR GUARD - 72"	1	2001376
~	OVERLAPPING DOOR GUARD - 79"	1	2002325
30	FIBERGLASS EVAPORATION BOARD	1	1122728
31	AIR DAM BRACKET (NOT SHOWN)	1	1112112
32	LOWER HINGE BRACKET (NOT SHOWN)	1	1121924

\*NOTE: WHEN ORDERING CABINET ASSEMBLY, PLEASE PROVIDE **9-CODE** OR **11-CODE** AND **MANUFACTURER'S DATE CODE**.

\*\*NOTE: WHEN ORDERING DECALS, PLEASE PROVIDE **STYLE**.

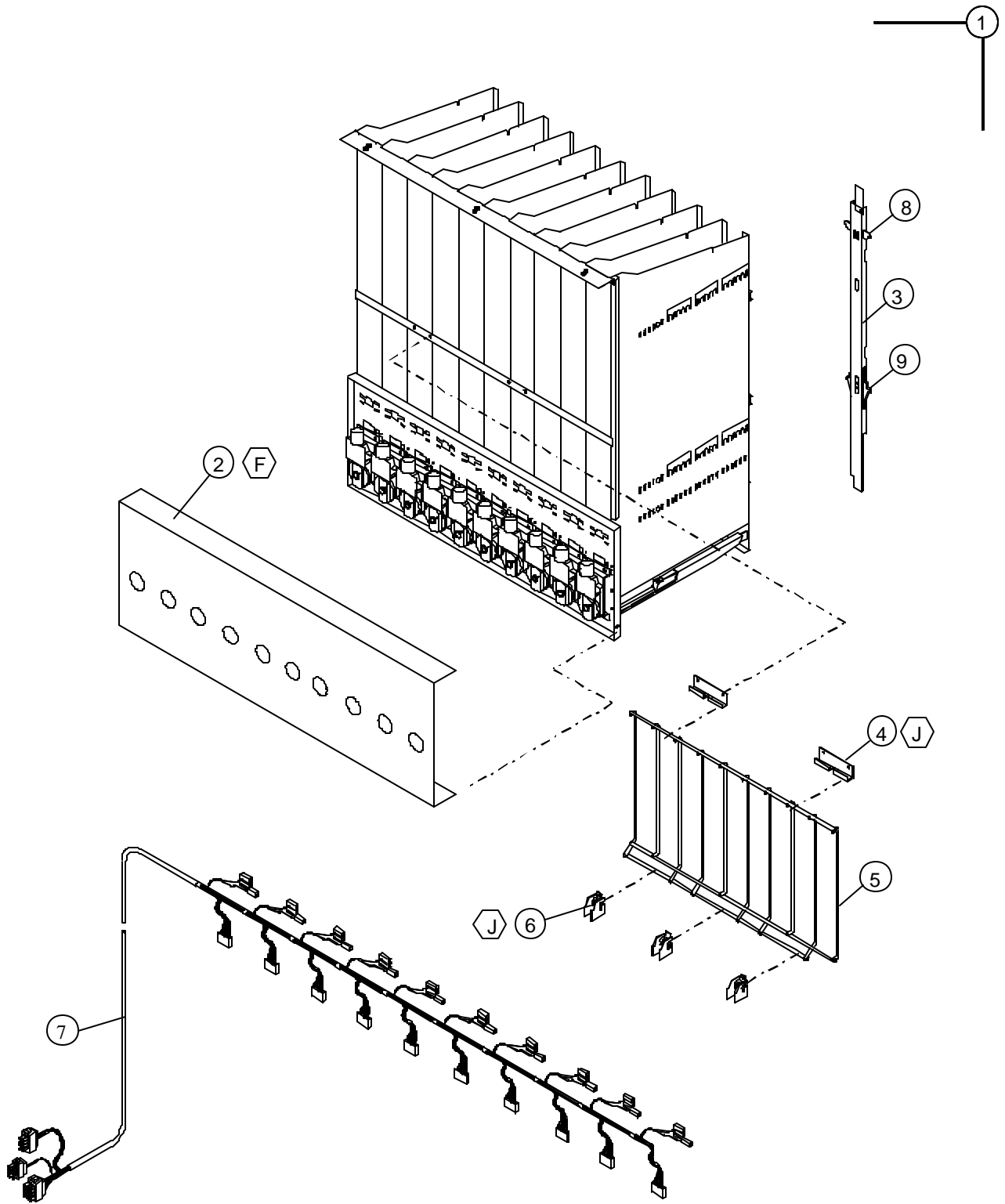



### V-MAX STACK ASSEMBLY

ITEM NO.	MODEL NUMBER		GIV	576	720	840	512/680	603/800
	DESCRIPTION	QTY REQ	PART NO.	PART NO	PART NO.	PART NO.	PART NO.	PART NO.
1	STACK CHASSIS ASSEMBLY	1	1112694-01	1112694-03	1112694-01	1112694-02	1005219-102	1005219-103
2	MECH COVER	1	1076634	1117724	1076634	1076634	1076634	1076634
3	BACK SPACER ASSEMBLY	10	2009473-01	2009473-01	2009473-01	2009473	2009473-02	2009473-03
4	HOOK RACK RETAINER	2	1086813	1086813	1086813	1086813	1086813	1086813
5	LOADING RACK / PRODUCT RETAINER	1	1086805-1	1117848	1086805-1	1086805-1	1086805-1	1086805-1
6	BRKT - LOADING RACK	3	1120095	1120095	1120095	1120095	1120095	1120095
7	MOTOR HARNESS	1	1120138	1117856	1120138	1120138	1120138	1120138
8	HANGER -TOP	1	1120489	1120489	1120489	1120489	1120489	1120489
9	HANGER - BOTTOM	1	1120490	1120490	1120490	1120490	1120490	1120490





### V-MAX STACK ASSEMBLY

ITEM NO.	MODEL NUMBER		GIV	576	720/840
	DESCRIPTION	QTY REQ	PART NO.	PART NO.	PART NO.
1	VEND MOTOR ASSEMBLY	10	1115821	1115821	1115821
2	RETAINER - CAM	1	1113244	1113244	1113244
3	TIMING CAM	1	1113236	1113236	1113236
4	SPRING	10	390326	390326	390326
5	SWITCH - SOLD-OUT	10	368299	368299	368299
6	SWITCH MOUNT - SOLD-OUT	10	1120037	1120037	1120037
7	FRONT MECH PLATE	1	1079023	1117678	1079023
8	SOLD-OUT LEVER - LONG	10	1112163	1112163	1112163
9	ANTI THEFT CLIP	40	389712	389712	389712
10	VEND BUCKET	10	1120146	1120146	1120146
11	* CLIP - SEE PRODUCT SET-UP GUIDE (SHORT - WHITE)	AR	1066104	1066104	1066104
12	* CLIP - SEE PRODUCT SET UP GUIDE (MEDIUM - GREY)	AR	1066112-1	1066112-1	1066112-1
13	* CLIP - SEE PRODUCT SET-UP GUIDE (TALL - BLACK)	AR	1066112	1066112	1066112
14	GAGE BAR	10	1111651	1111651	1111651
15	* PRODUCT SPACER - FLAT .06	AR	1078848	1078848	1078848
16	*PRODUCT SPACER - 0.27	AR	1122032	1122032	1122032
17	* PRODUCT SPACER - 0.37	AR	1078864	1078864	1078864
18	* PRODUCT SPACER - 0.47	AR	1078872	1078872	1078872
19	COTTER CLIP - GAGE BAR	10	387450	387450	387450
20	GATE	10	1121282	1121282	1121282
21	BEARING - GATE (FRONT & REAR)	20	385603-5	385603-5	385603-5
22	E-CLIP - GATE	20	388589	388589	388589
23	SPRING	10	387849	387849	387849
24	GATE LINK	10	1120140	1120140	1120140
25	BUSHING - VEND BUCKET (FRONT & REAR)	20	1008706	1008706	1008706
26	MOTOR COUPLING	10	1076465	1076465	1076465
27	COTTER CLIP - SPACER	1	1032526	1032526	1032526
28	FOUR-DEEP CLIP	AR	1122103	1122103	1122103
29	3 <sup>RD</sup> CAN CLIP	AR	1121704	1121704	1121704

\* NOTE: DEPENDING ON PRODUCT SET-UP

\*\* NOTE: ALL 576 MODELS WILL ONLY HAVE EIGHT COMPONENTS

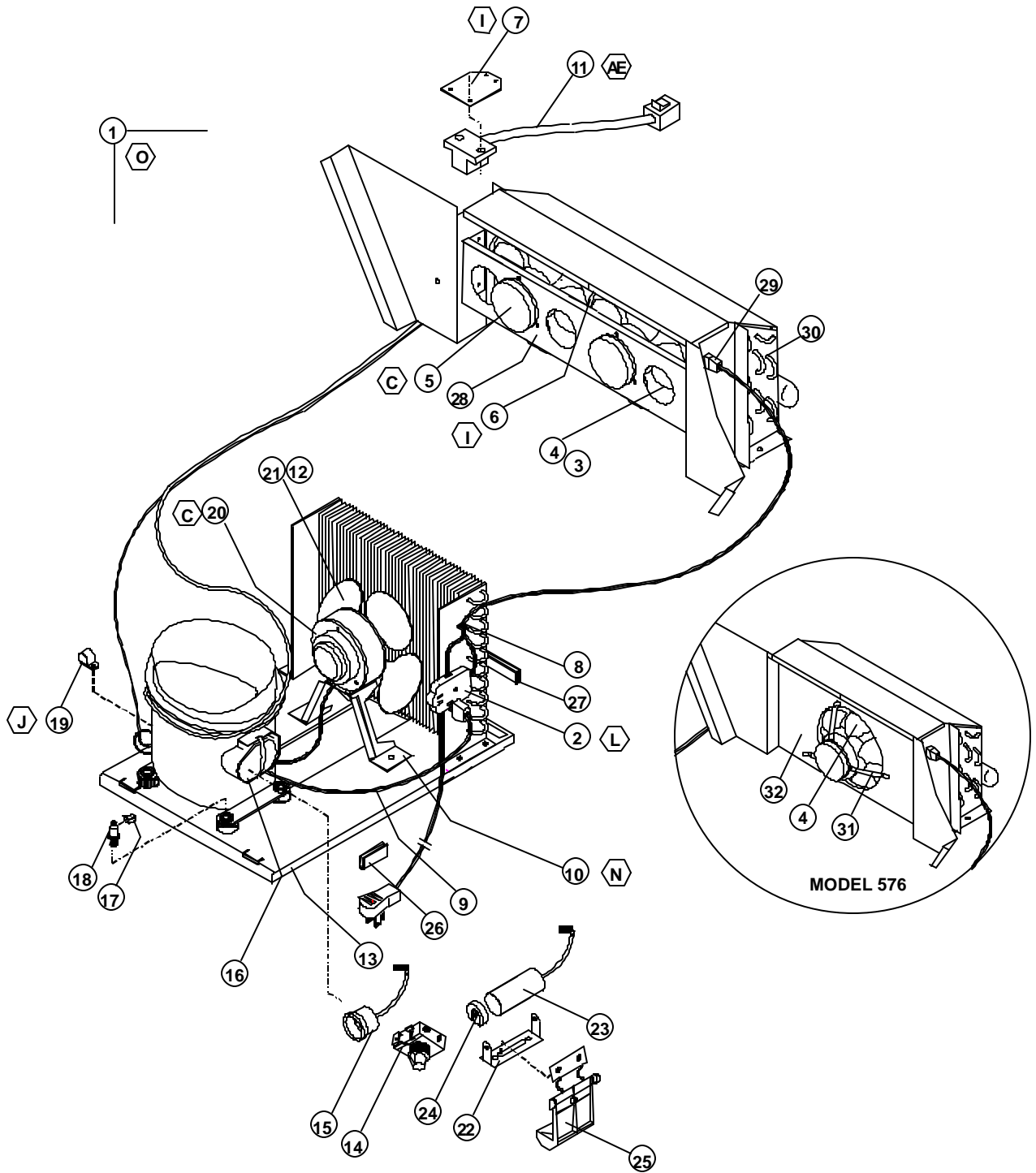



### V-MAX REFRIGERATION ASSEMBLY

ITEM NO.	DESCRIPTION	QTY REQ	110V PART NO.
1	REFRIGERATION ASSEMBLY D90	1	1120341
2	SERVICE PLUG ASSEMBLY US	1	<a href="#">1120617</a>
3	FAN CLIP - EVAPORATOR	2	336640
4	FAN BLADE	2	<a href="#">1113562</a>
5	EVAPORATOR FAN MOTOR	2	<a href="#">42321-17</a>
6	ORIFICE PLATE - EVAPORATOR FAN	1	1120571
7	BRACKET TEMP SENSOR	1	<a href="#">1121777</a>
8	CLAMP PUSH MOUNT	1	384692-3
9	COMPRESSOR CORD	1	1121020
10	BRACKET - CONDENSER FAN	1	389797
11	TEMP SENSOR	1	<a href="#">1121777</a>
12	FAN CLIP - CONDENSER	1	V42323
13	BASE - REFRIGERATION	1	1122470
14	START RELAY (INCLUDED IN ASSEMBLY <a href="#">513506066</a> )	1	--
15	OVERLOAD PROTECTOR (INCLUDED IN ASSEMBLY <a href="#">513506066</a> )	1	--
16	COVER – OVERLOAD (INCLUDED IN ASSEMBLY <a href="#">513506066</a> )	1	--
17	CLIP - COMPRESSOR MOUNT	4	336640
18	STUD COMPRESSOR MOUNT	4	390102
19	CLAMP	1	324099-3
20	FAN MOTOR - CONDENSER	1	42321-36
21	FAN BLADE - CONDENSER	1	320766
22	BRACKET – CAPACITOR (INCLUDED IN ASSEMBLY 1112805)	1	--
23	CAPACITOR (INCLUDED IN ASSEMBLY 1112805)	1	--
24	END CAP – CAPACITOR (INCLUDED IN ASSEMBLY 1112805)	1	--
25	CLIP - CAPACITOR	1	1076481
26	EDGE TRIM - SHORT	3	<a href="#">388304-1</a>
27	EDGE TRIM - LONG	1	<a href="#">388304-3</a>
28	BRACKET - FAN MOTOR	1	389797
29	EVAPORATOR HARNESS	1	<a href="#">1122193</a>
30	EVAPORATOR	1	385470
31	EVAPORATOR FAN BRACKET MOUNT	3	<a href="#">1117996</a>
32	ORIFICE PLATE- EVAPORATOR FAN (SINGLE)	1	<a href="#">390228</a>

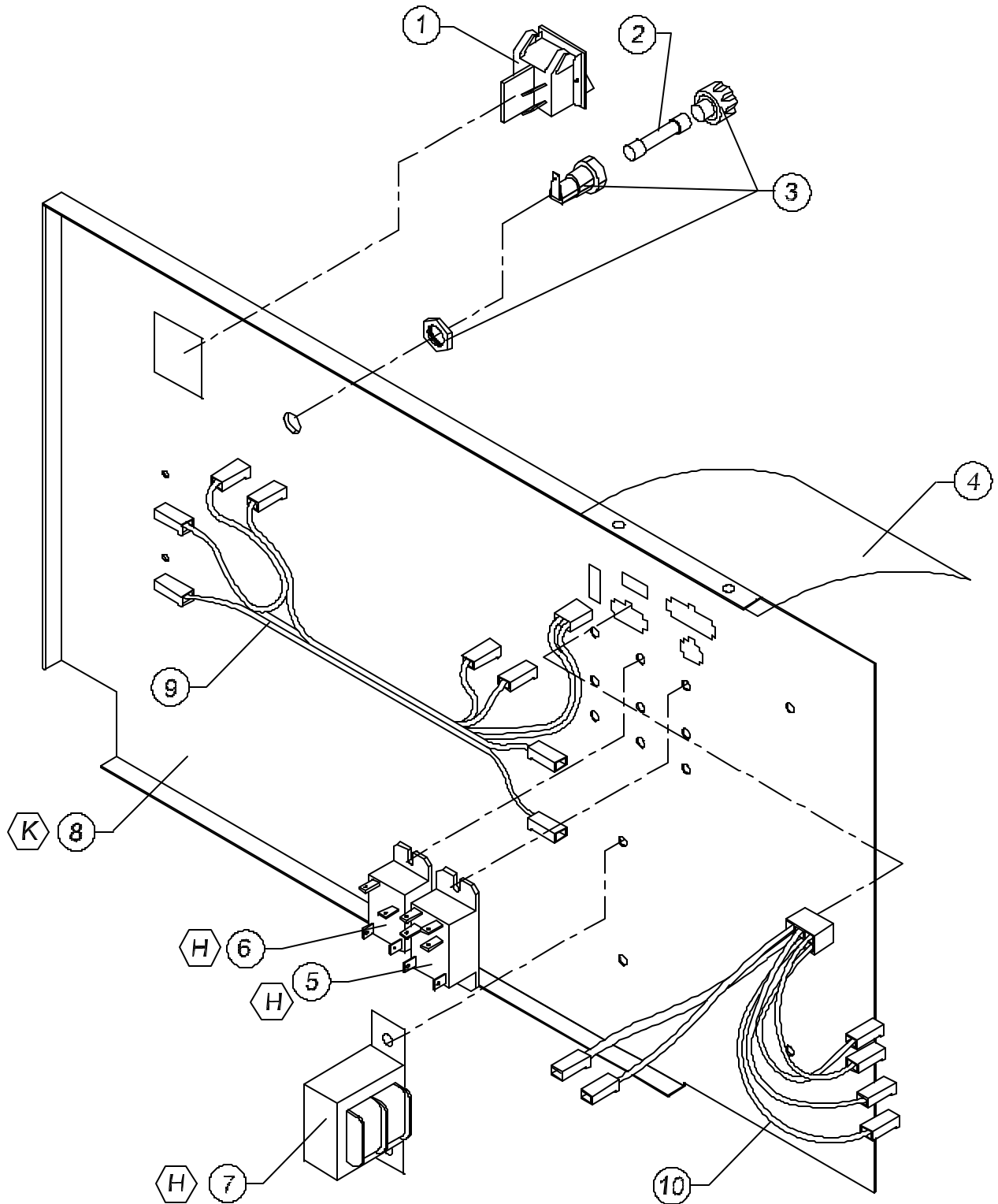



### V-MAX AIR DAM ASSEMBLY

ITEM NO.	DESCRIPTION	QTY REQ	PART NO. 576	PART NO. GIV/720/840/ 680/800
1	SWITCH	1	1084546	1084546
2	0.8 AMP FUSE	1	1053864	1053864
3	FUSE HOLDER	1	387966	387966
4	RAIN CURTAIN	1	1121660	1121660
5	RELAY - REFRIGERATION	1	1079724	1079724
6	RELAY - LIGHT	1	1089333	1089333
7	TRANSFORMER (24 VOLT)	1	1111201	1111201
8	PANEL - AIR DAM	1	1121659	1121202
9	HARNESS - POWER	1	1110864	1110864
10	HARNESS - RELAYS AND TRANSFORMER	1	1078732	1078732



## NOTES



# V-MAX

## PARTS SECTION COCA - COLA

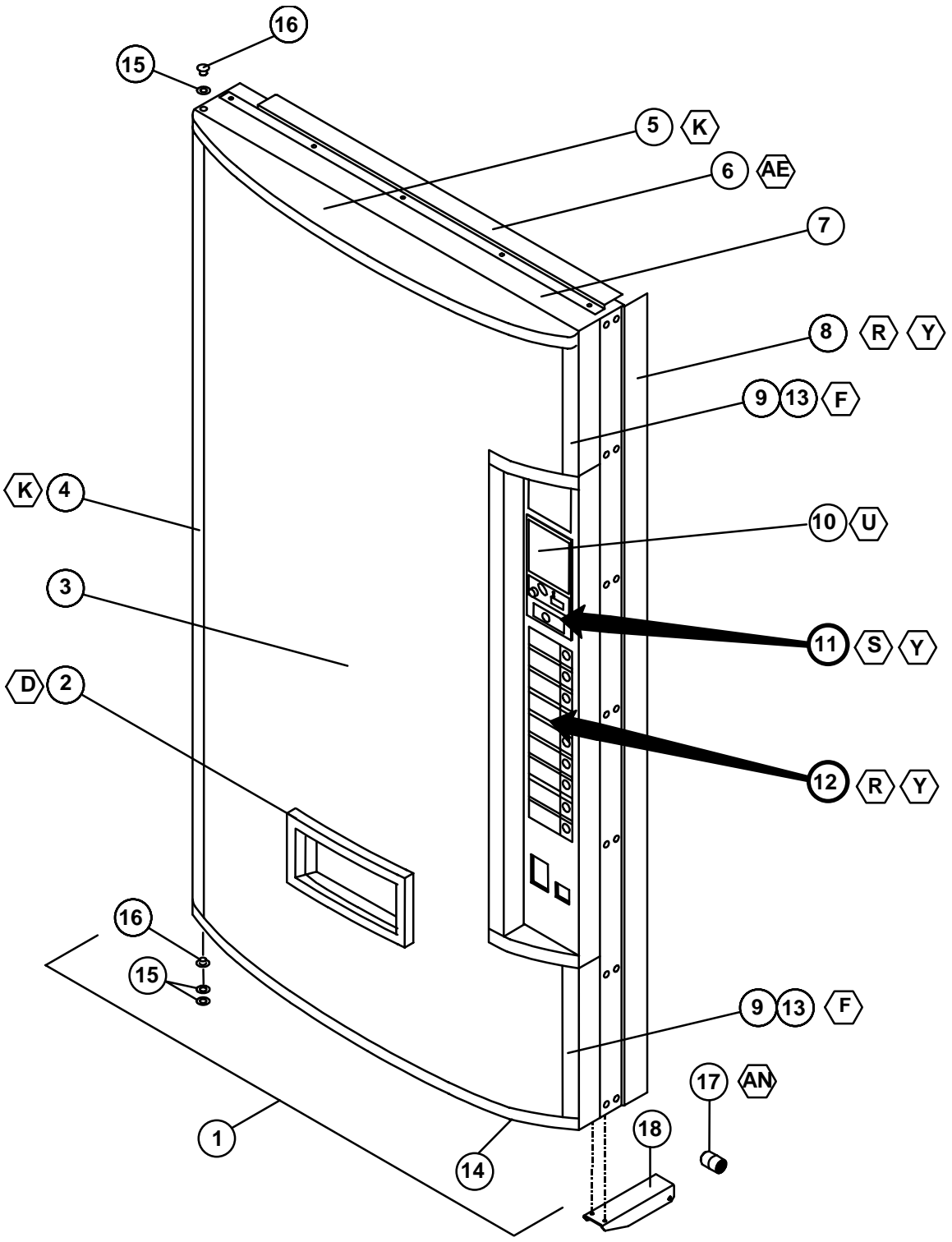



### V-MAX COCA-COLA MAIN DOOR

ITEM NO.	DESCRIPTION	MODEL NUMBER	720	840
			QTY REQ	PART NO.
1	OUTER DOOR – 9 SELECT	1	*	*
2	EYELET TRIM	1	388271	388271
3	SIGN FACE	1	**	**
4	SIGN TRIM - LEFT	1	388125-2B	388125B
5	SIGN CAP - UPPER	1	1114341	1114341
6	RAIN GUARD	1	2000848	2000848
7	DOOR FRAME WELD	1	1121220	1121221
8	DOOR GUARD	1	2010131	2009503
9	SIGN TRIM RIGHT (TOP - BOTTOM)	2	1084538	1084538-1
10	DBV PLUG	1	2001228	2001228
11	LOCK ASSEMBLY (SEE PAGES CC-8 - CC-9)	1	~	~
12	SELECTION PANEL (SEE PAGES CC-6 - CC-7)	1	~	~
13	SIGN TRIM RETAINER	2	1084589	1084589-1
14	SIGN CAP BOTTOM	1	1114341-1	1114341-1
15	FLAT WASHER 3/8"	3	V801491	V801491
16	BUSHING	2	388094	388094
17	ROLLER	1	1120388	1120388
18	BRACKET ROLLER	1	1120552	1120552

\*NOTE: WHEN ORDERING DOOR ASSEMBLY, PLEASE PROVIDE **9-CODE** OR **11-CODE** AND **MANUFACTURER'S DATE CODE**.

\*\*NOTE: WHEN ORDERING SIGN FACE, PLEASE PROVIDE **STYLE**.

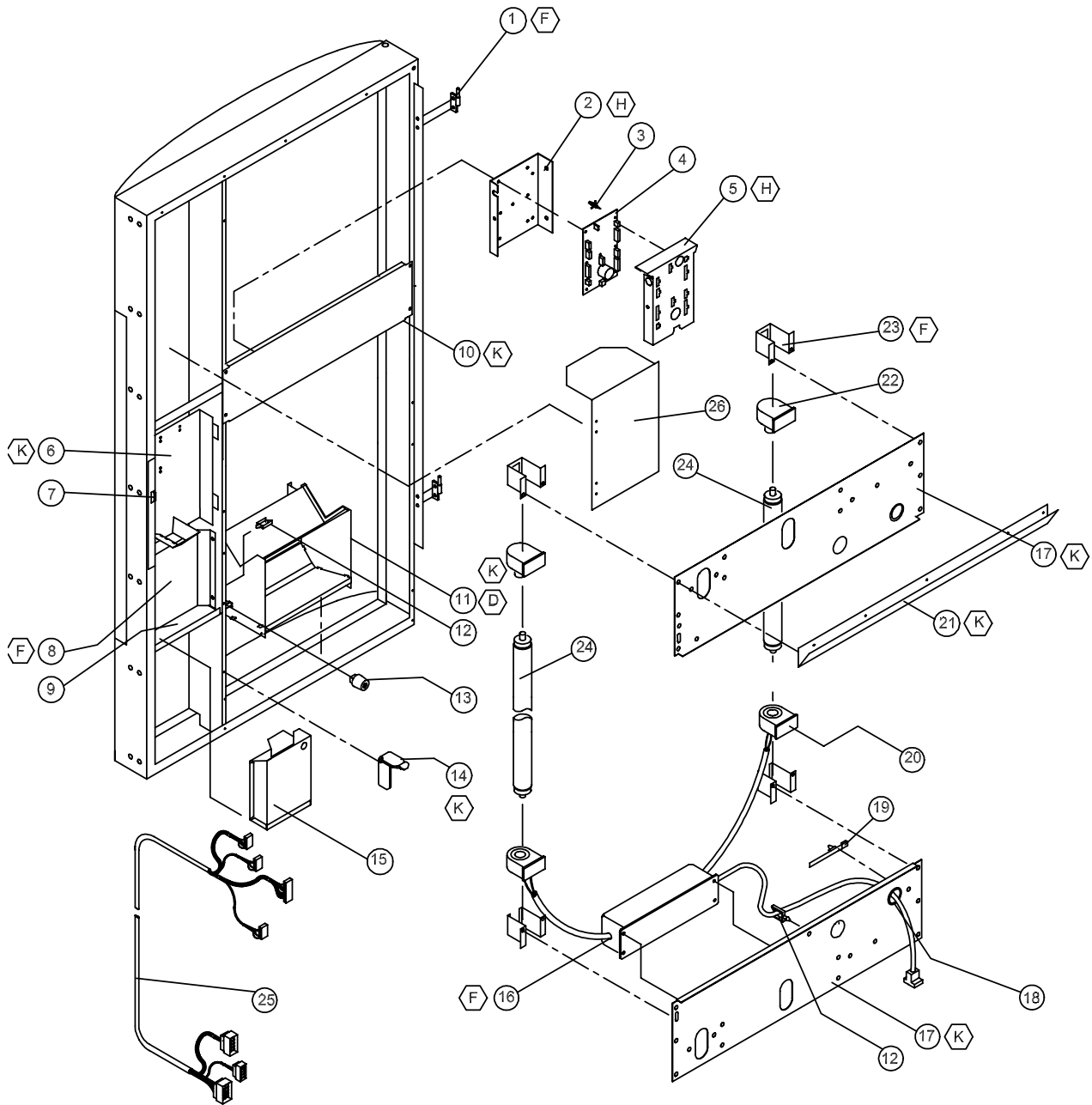



### V-MAX COCA-COLA MAIN DOOR

ITEM NO.	DESCRIPTION	MODEL NUMBER	720/840 PART NO.
1	HINGE MALE - INNER DOOR	2	<a href="#">1121287</a>
2	MOUNTING BRACKET - CONTROLLER	1	<a href="#">1077716</a>
3	STAND OFF	6	<a href="#">1121740</a>
4	PCBA VEC 9.2 CONTROLLER	1	1110538-38
5	COVER PANEL	1	1077724
6	COIN DOOR ASSEMBLY	1	1081112
7	LATCH - COINAGE DOOR	1	<a href="#">1085546</a>
8	BARRIER PANEL	1	1117147
9	BULKHEAD COIN BOX	1	1112155
10	SHEAR PANEL - MIDDLE	1	1120713
11	DELIVERY HOPPER ASSEMBLY	1	<a href="#">133574-10</a>
12	HARNESS CLIP	5	<a href="#">384692-2</a>
13	DOOR BUMPER	2	1036912
14	RAMP/CATCH - INNER DOOR	1	<a href="#">1121714</a>
15	COIN BOX	1	133563
16	BALLAST 115V	1	388405
17	SHEAR PANEL - LOWER / UPPER	2	388117
18	GROMMET 3/2"	1	327021
19	HARNESS TIE	2	<a href="#">1088864</a>
20	LAMP HOLDER - FIXED	2	<a href="#">388406</a>
21	RAIN GUTTER	1	<a href="#">1121204</a>
22	LAMP HOLDER - PLUNGER	2	<a href="#">388407</a>
23	BRACKET - LAMPHOLDER	4	<a href="#">1122305</a>
24	LAMP - 64"	2	388408-1
~	LAMP - 72"	2	388408
25	DOOR HARNESS	1	<a href="#">1077686</a>
26	DBV GUARD ASSEMBLY <b>(OPTIONAL)</b>	1	1089694
27	RAIN CURTAIN, BALLAST (NOT SHOWN)	1	1121838

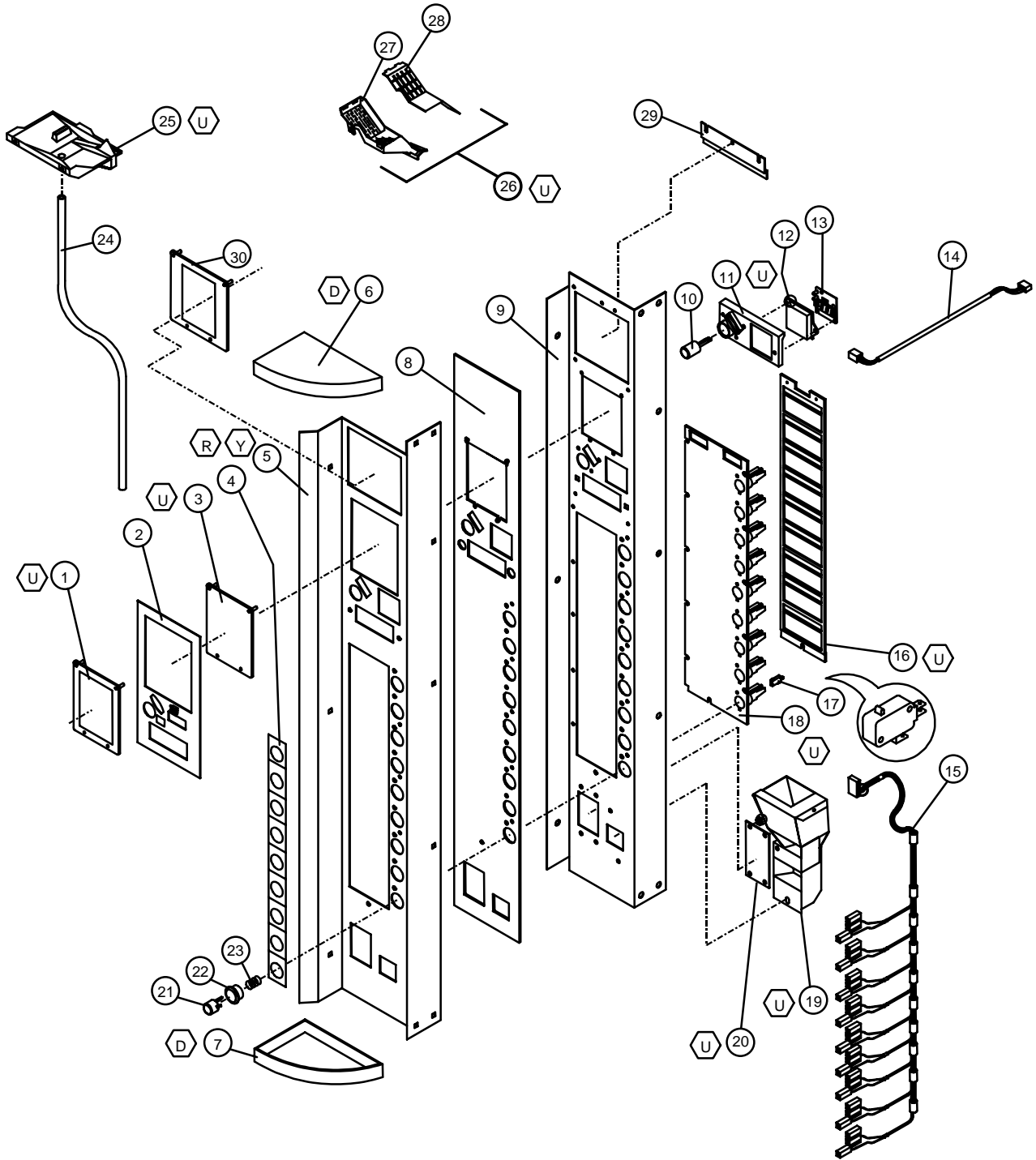



### V-MAX COCA-COLA SELECTION PANEL

ITEM NO.	DESCRIPTION	QTY REQ	PART NO.
~	SELECTION PANEL ASSY.	1	1112643-01
1	DBV COLLAR	1	<a href="#">2001201</a>
2	COIN INSERT - DECAL	1	<a href="#">1044885</a>
3	PLUG - DBV	1	2001228
4	DECORATIVE PANEL - 9-SELECT	1	1029576-5
5	OVERLAY PANEL - 9-SELECT	1	1122713-4
6	PANEL CAP - TOP	1	<a href="#">388139</a>
7	PANEL CAP - BOTTOM	1	<a href="#">388140</a>
8	COVER PANEL	1	1122419
9	SELECTION PANEL	1	2001716
10	BUTTON - COIN RETURN	1	<a href="#">1050473</a>
11	GUIDE PLATE - COIN INSERT/RETURN	1	1050481
12	LENS - DISPLAY	1	1039652
13	PCB - DIGITAL DISPLAY - ELECTRONIC	1	1089678
14	DISPLAY HARNESS	1	1111252
15	SELECTION HARNESS - 9-SELECT	1	1111279
16	CARRIER STRIP ASSEMBLY	1	1017845
17	SWITCH SELECTION	9	<a href="#">368299</a>
18	SWITCH MOUNT	1	1120827
19	COIN RETURN CUP ASSEMBLY	1	<a href="#">1079546</a>
20	PLUG - CROWN PULLER	1	1044737
21	BUTTON SELECTION	9	<a href="#">1016741</a>
22	BUTTON HOUSING (BUSHING)	9	1016768
23	SPRING SELECTION	9	<a href="#">1029959</a>
24	DRAIN TUBING	1	<a href="#">1110619</a>
25	TRAY WATER COLLECTION	1	<a href="#">1110562</a>
26	COIN CHUTE ASSEMBLY	1	<a href="#">1087961</a>
27	COIN CHUTE	1	<a href="#">1002333</a>
28	COVER CHUTE	1	<a href="#">1002341</a>
29	RETAINER - POS LABEL	2	1110155
30	BRACKET - DBV (POS) <b>(OPTIONAL)</b>	1	1089716
31	POS BACKING PLATE <b>(NOT SHOWN)</b>	1	1122389
32	MDB HARNESS <b>(NOT SHOWN)</b>	1	1089341

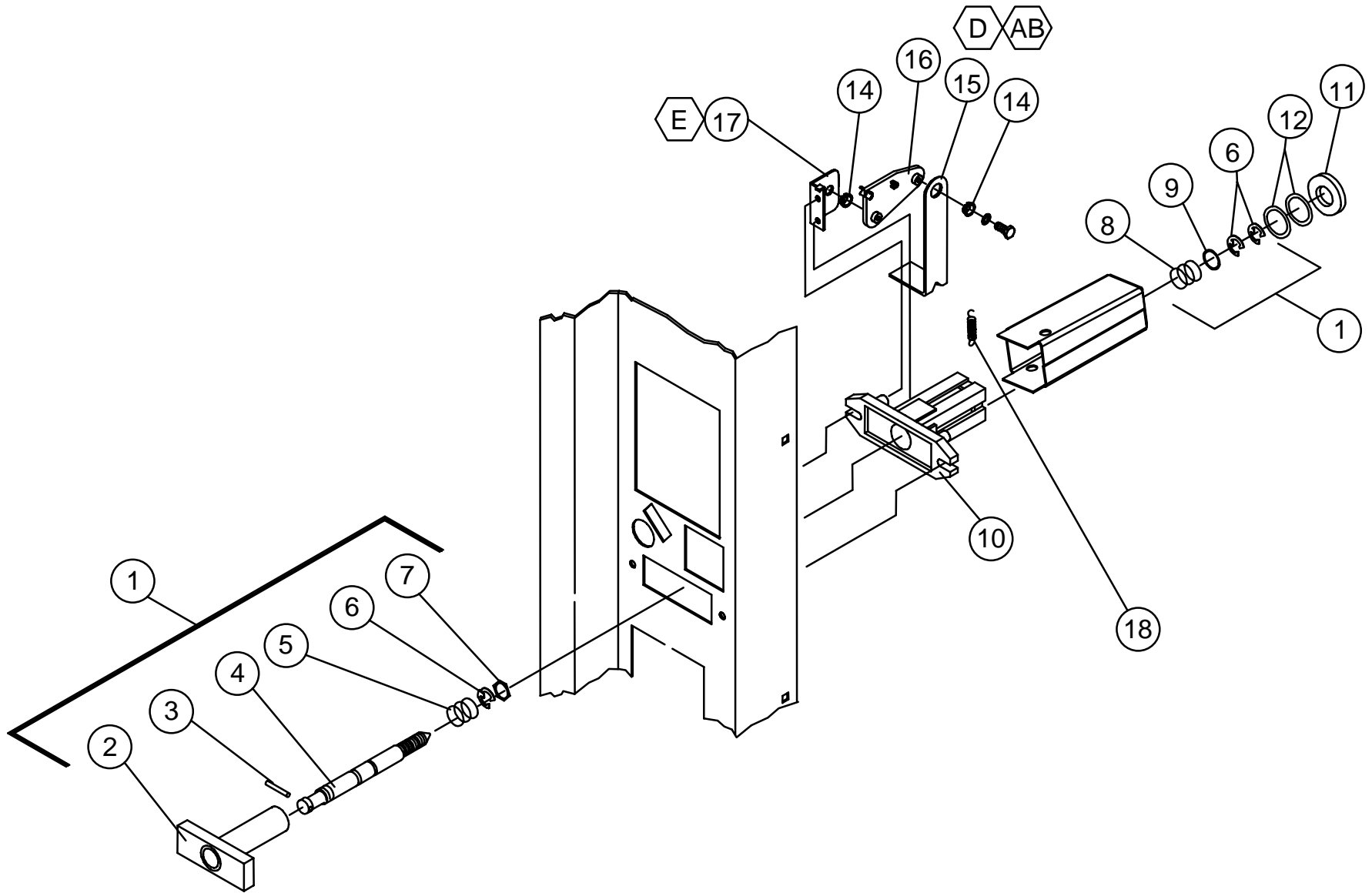



### V-MAX COCA-COLA LOCK ASSEMBLY

ITEM NO.	DESCRIPTION	QTY REQ	PART NO.
1	T-HANDLE LOCK ASSEMBLY – ROBO DOOR	1	1114422
--	T-HANDLE LOCK ASSEMBLY - LANDSCAPE	1	<a href="#">1002635</a>
2	T-HANDLE	1	<a href="#">1002392</a>
3	PIN - STUD	1	387601
4	LOCK STUD - QUICKER LOCK	1	<a href="#">1049724</a>
5	SPRING	1	1111554
6	E-RING RETAINER	3	<a href="#">388589</a>
7	HEX WASHER	1	387600
8	SPRING - HEAVY	1	<a href="#">389690</a>
9	FLAT WASHER	1	387718
10	FLANGE	1	<a href="#">1002384</a>
11	LOCK STUD COVER	1	1122126
12	WASHER ½"	2	<a href="#">V801023</a>
13	VAPOR SEAL	1	<a href="#">388132</a>
14	BUSHING (BEARING MECH)	2	<a href="#">385603-4</a>
15	LEVER - COIN RETURN	1	<a href="#">1052619</a>
16	CRANK - COIN RETURN LEVER	1	<a href="#">1002244</a>
17	PIVOT BRACKET - COIN RETURN	1	<a href="#">1002252</a>
18	SPRING - COIN RETURN LEVER	1	<a href="#">1060023</a>



## NOTES



# **V-MAX**

**MARKETING VENDOR  
PARTS SECTION  
COCA - COLA**

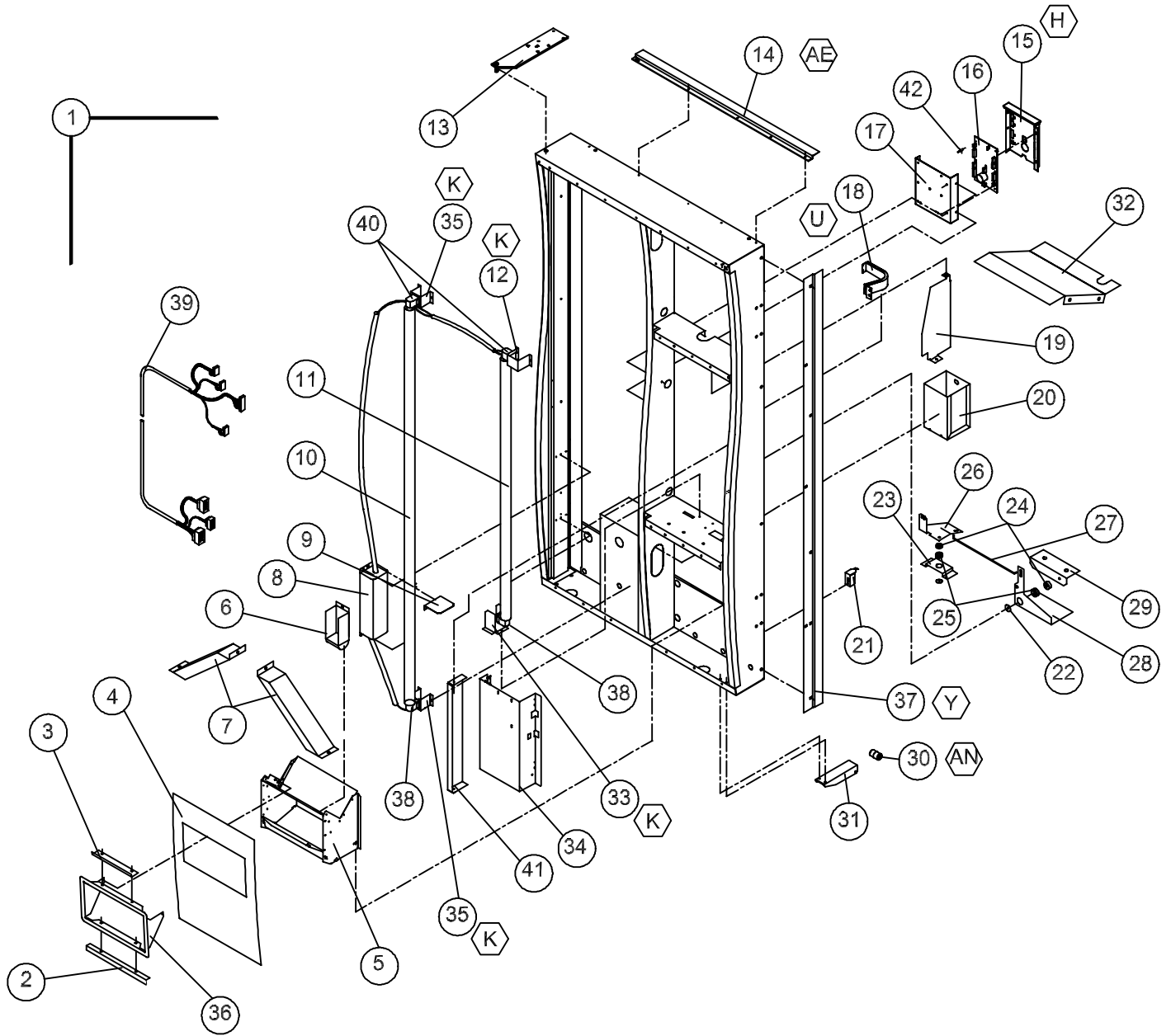



### MARKETING VENDOR COCA-COLA MAIN DOOR

ITEM NO.	DESCRIPTION	MODEL NUMBER	603/800	512/680
			PART NO.	PART NO.
1	OUTER DOOR - 13-SELECT	1	*	*
2	BRACKET - LOWER EYELET	1	1118813	1118813
3	BRACKET - UPPER EYELET	1	1118805	1118805
4	SUB-PANEL (HOPPER GRAPHIC)	1	1120059	1120059
5	HOPPER ASSEMBLY	1	1120063	1120063
6	COIN RETURN CUP	1	1120067	1120067
7	PASS CHUTE ASSEMBLY	2	1120068	1120068
8	BALLAST	1	388405	388405
9	RAIN SHIELD - BALLAST	1	1118503	1118503
10	LAMP - 64" / 72"	1	388408	388408-1
11	LAMP - 48"	1	1115643	1115643
12	BRACKET - LAMP HOLDER - UPPER	1	1120354	1120354
13	TOP HINGE PLATE	1	1113007	1113007
14	RAIN GUARD	1	2010174	2010174
15	COVER	1	1077724	1077724
16	VEC 9.2 BOARD CONTROLLER	1	1110538-38	1110538-38
17	BRACKET - VEC MOUNTING	1	<a href="#">1077716</a>	<a href="#">1077716</a>
18	COIN INSERT CHUTE	1	1119686	1119686
19	DBV BARRIER PANEL	1	1120123	1120123
20	COIN BOX ASSEMBLY	1	1120060	1120060
21	INNER DOOR RAMP	1	1016962	1016962
22	WASHER	1	<a href="#">389026</a>	<a href="#">389026</a>
23	PIVOT BRACKET - CRANK	1	1120643	1120643
24	BUSHING	2	<a href="#">1116634</a>	<a href="#">1116634</a>
25	BEARING	2	385603-6	385603-6
26	CRANK	1	1120642	1120642
27	LINK - CRANK	1	1120026	1120026
28	LEVER	1	1120647	1120647
29	PIVOT BRACKET	1	1120028	1120028
30	ROLLER	1	<a href="#">1120388</a>	<a href="#">1120388</a>
31	BRACKET ROLLER	1	1120552	1120552
32	BULKHEAD - MIDDLE	1	1122307	1122307
33	BRACKET - LAMPHOLDER - LOWER	1	1115562	1121418
34	COINAGE DOOR ASSEMBLY	1	1120054	1120054
~	LATCH - COINAGE DOOR (NOT SHOWN)	1	<a href="#">1085546</a>	<a href="#">1085546</a>
35	BRACKET LAMP - LEFT	2	1119228	1119228
36	EYELET TRIM HOPPER RED	1	1120046	1120046
37	DOOR GUARD	1	2010177	2010177-1
38	LAMP HOLDER - FIXED	2	<a href="#">388406</a>	<a href="#">388406</a>
39	DOOR HARNESS	1	<a href="#">1077686</a>	<a href="#">1077686</a>
40	LAMP HOLDER - PLUNGER	2	<a href="#">388407</a>	<a href="#">388407</a>
41	BULKHEAD - COINAGE	1	1119562	1119562
42	STAND OFF	6	<a href="#">1121740</a>	<a href="#">1121740</a>



\*NOTE: WHEN ORDERING DOOR ASSEMBLY. PLEASE PROVIDE 9-CODE OR 11-CODE AND MANUFACTURER'S DATE CODE.

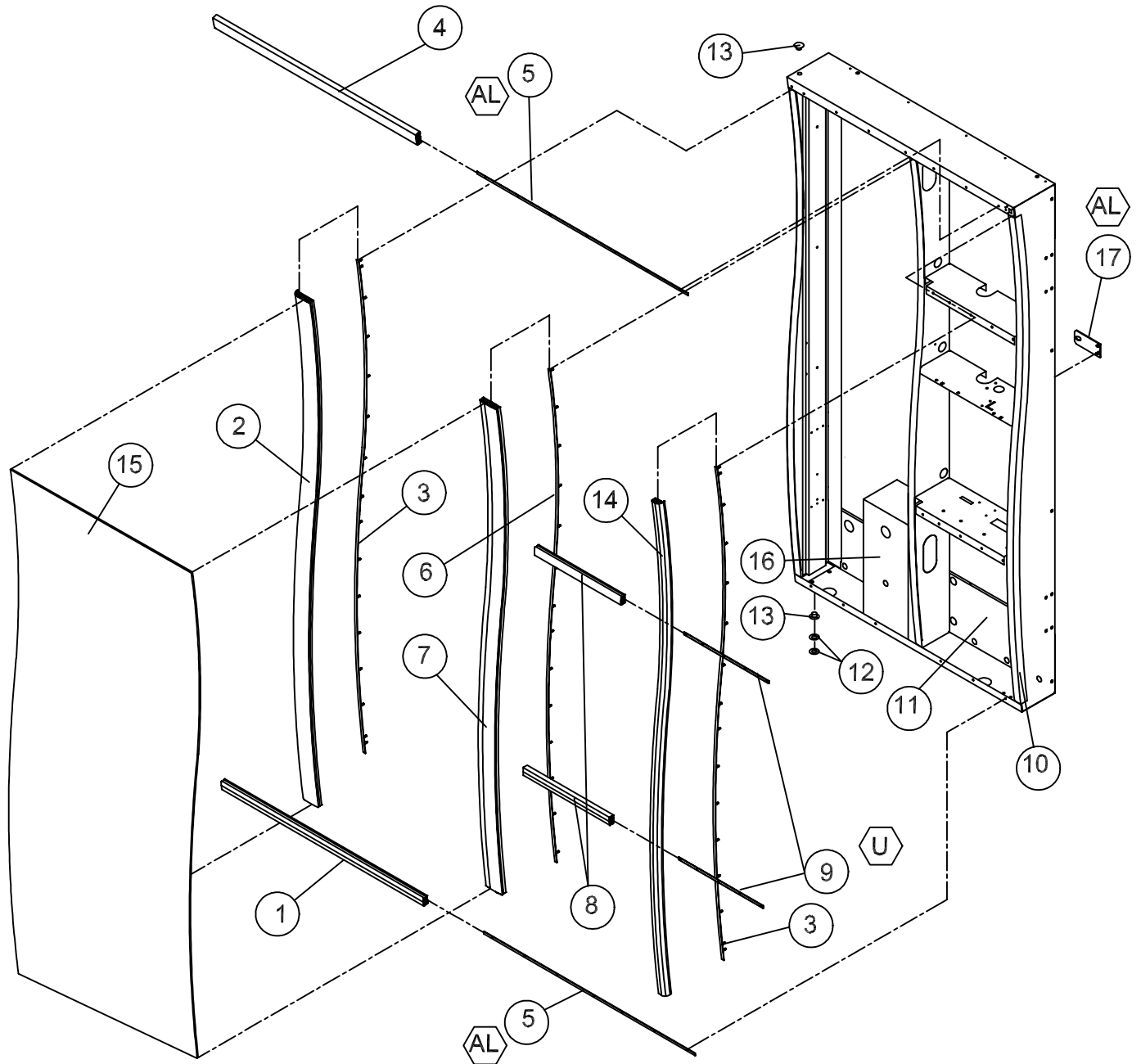



**MARKETING VENDOR COCA-COLA MAIN DOOR**

ITEM NO.	DESCRIPTION	MODEL NUMBER	603/800	512/680
			PART NO.	PART NO.
1	TRIM - BOTTOM	1	1119015-1	1119015-1
2	TRIM - HINGE SIDE	1	1119011	1119011-1
3	PLATE- SIGN TRIM - SIDES	2	1115387	1120125
4	TRIM - TOP	1	1120109	1120109
5	PLATE - TRIM TOP AND BOTTOM	2	1120032	1120032
6	PLATE - SIGN TRIM - CENTER	1	1115380	1120053
7	TRIM - CENTER	1	1114033	1114033-1
8	TRIM - MODULE	2	1119015	1119015
9	PLATE - TRIM MODULE	2	1120127	1120127
10	DOOR WELD	1	2010169	2010169-1
11	SHEAR PANEL - LOWER	1	388117	388117
12	FLAT WASHER 3/8" - BOTTOM	2	V801491	V801491
13	BUSHING	2	388094	388094
14	TRIM - RIGHT	1	1119010-2	1119010-3
15	SIGN FACE - "BOTTLE ON ICE"	1	**	**
16	COIN BOX GUARD ASSEMBLY	1	1121509	1121509
17	LOCK STUD GUIDE	1	1121356	1121356

\*\*NOTE: WHEN ORDERING SIGN FACE, PLEASE PROVIDE **STYLE**.

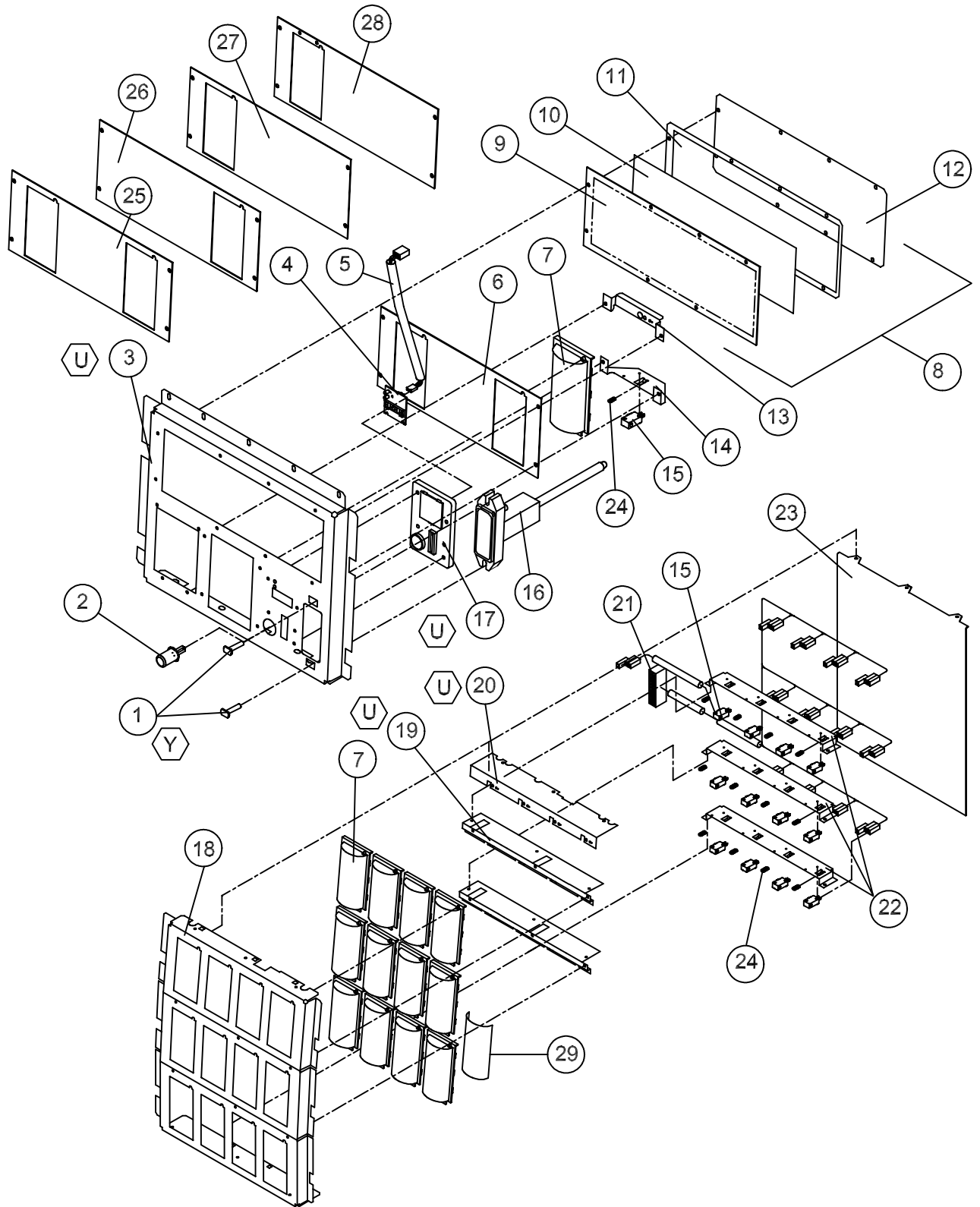



**MARKETING VENDOR COCA-COLA SELECTION PANEL**

ITEM NO.	DESCRIPTION	QTY REQ	PART NO.
1	T-HEAD BOLT 1/4"	2	V802148
2	COIN RETURN BUTTON	1	<a href="#">1050473</a>
3	TRANSACTION PANEL	1	1120130-01
4	DISPLAY BOARD	1	1089678
5	DISPLAY HARNESS	1	1111252
6	ADAPTOR PLATE - FEATURE BUTTON	1	<a href="#">1120241</a>
7	SELECTION BUTTON - FEATURE BUTTON	13	1113171
8	POS WINDOW ASSEMBLY	1	1120205
9	SMALL POS WINDOW	1	1120118
10	GRAPHIC - SMALL POS WINDOW (THIRSTY DECAL)	1	1093588-PS1
11	SPACER - POS WINDOW	1	1120120
12	PLATE - POS WINDOW	1	1120119
13	RETAINER -BUTTON TOP	1	1121024
14	RETAINER - BUTTON BOTTOM	1	1120015
15	SWITCH - SELECTION	13	1114791
16	LOCK ASSEMBLY - SEE PAGES MDC-8 - MDC-9	1	~
17	COIN INSERT GUIDE PLATE	1	1114872
18	SELECTION PANEL	1	1120044
19	RETAINER SWITCH MOUNT	2	1113848
20	RETAINER SELECTION BUTTON	1	1121025
21	SELECTION HARNESS	1	1113937
22	RETAINER BOTTOM SELECTION BUTTON	3	1120030
23	RAIN CURTAIN	1	1120114
24	SPRING	13	<a href="#">1029959</a>
25	ADAPTOR PLATE - DOUBLE DBV <b>(OPTIONAL)</b>	1	1120241-01
26	ADAPTOR PLATE - NO DBV <b>(OPTIONAL)</b>	1	1120241-02
27	ADAPTOR PLATE DECAL - NO FEATURE BUTTON <b>(OPTIONAL)</b>	1	1093599-CY4
28	ADAPTOR PLATE - NO FEATURE BUTTON <b>(OPTIONAL)</b>	1	1120241-03
29	FLAVOR LABELS		*

\* WHEN ORDERING FLAVOR LABELS, PLEASE PROVIDE STYLE.

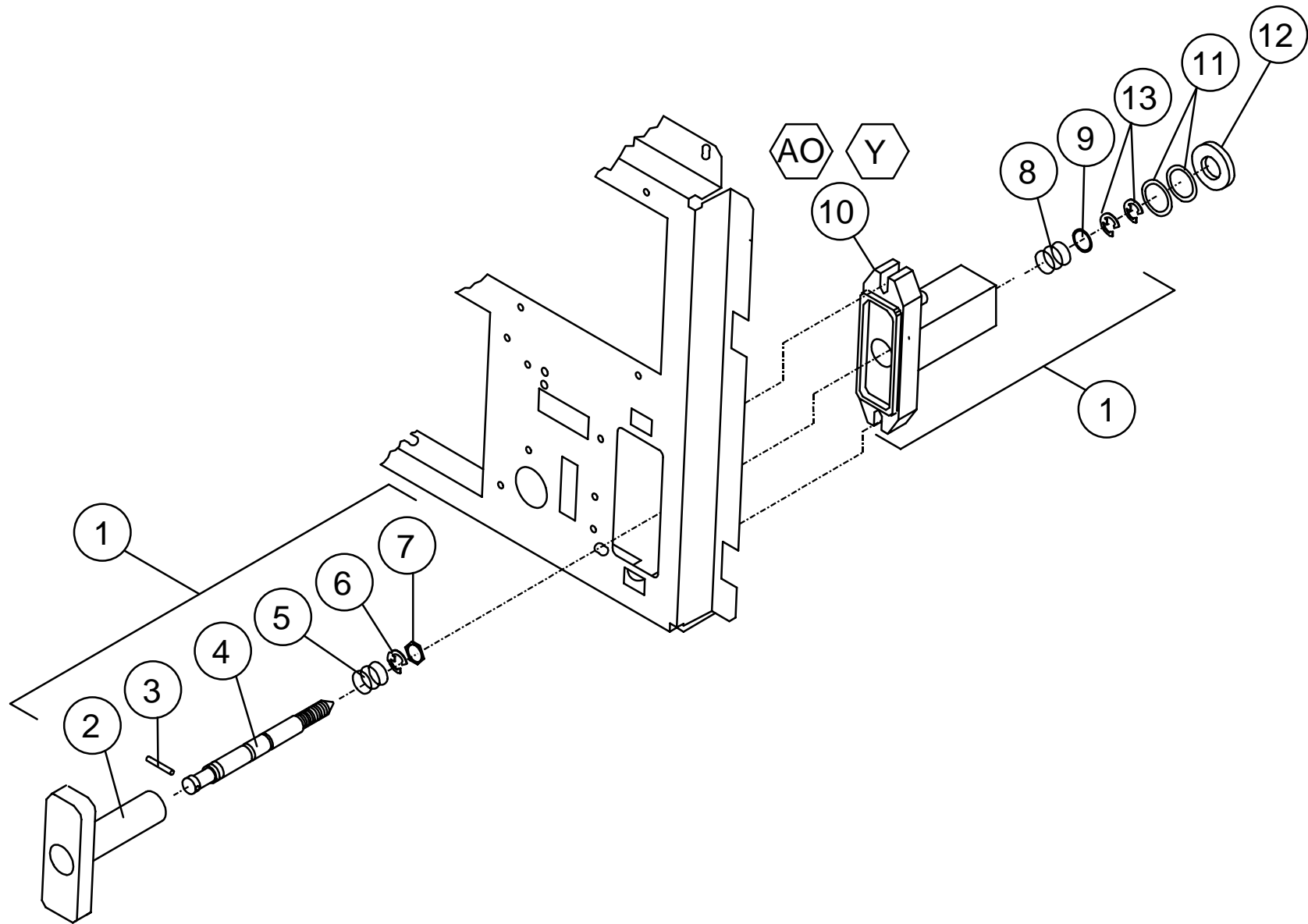



### MARKETING VENDOR COCA-COLA LOCK ASSEMBLY

ITEM NO.	DESCRIPTION	QTY REQ	PART NO.
1	T-HANDLE LOCK ASSEMBLY	1	<a href="#">1119236</a>
2	T-HANDLE	1	1116732
3	PIN - STUD	1	387601
4	LOCK STUD	1	1114945
5	SPRING	1	389691
6	E-RING RETAINER	1	<a href="#">388589</a>
7	HEX WASHER	1	387600
8	SPRING - HEAVY	1	<a href="#">389690</a>
9	FLAT WASHER	1	387718
10	FLANGE	1	1116724
11	WASHER	1	<a href="#">V801023</a>
12	VAPOR SEAL	1	<a href="#">388132</a>
13	E-RING RETAINER	2	<a href="#">388589</a>
~	GUARD - T-HANDLE LOCK ASSEMBLY (NOT SHOWN)	1	1119554

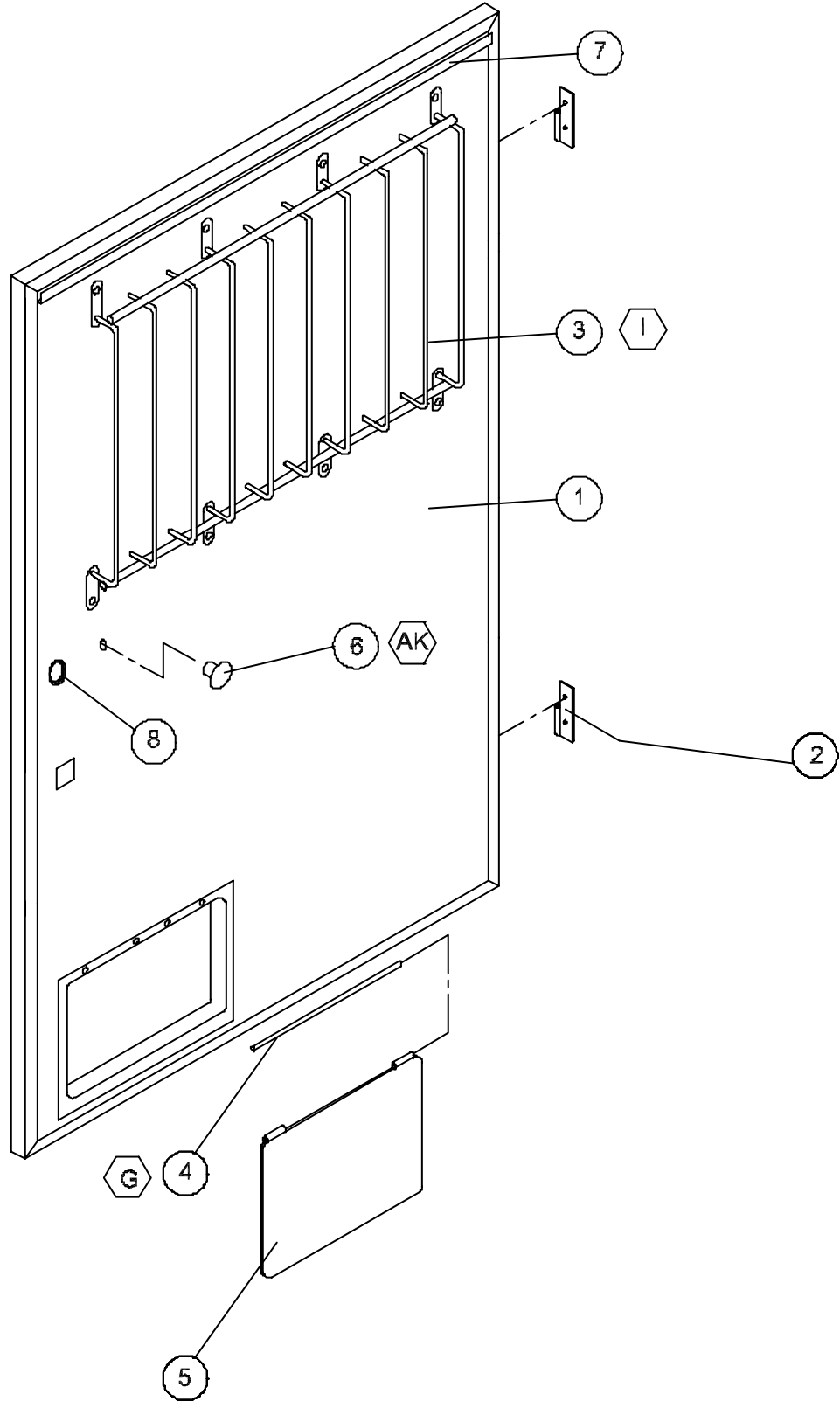



**MARKETING VENDOR COCA-COLA INNER DOOR ASSEMBLY**

ITEM NO.	MODEL NUMBER		603/800	512/680
	DESCRIPTION	QTY REQ	PART NO.	PART NO.
1	INNER DOOR ASSEMBLY (FOAMED)	1	134302-52	134302-51
2	HINGE - FEMALE	2	<a href="#">1121286</a>	<a href="#">1121286</a>
3	PROD. RETAINER UPPER	1	1117562-03	1120633-2
4	PIN - HINGE	1	389985	389985
5	FLAP - DOOR (REVERSIBLE)	1	<a href="#">1013076</a>	<a href="#">1013076</a>
6	KNOB - DOOR	1	388305	388305
7	RAIN SEAL - INNER DOOR	1	<a href="#">1111732</a>	<a href="#">1111732</a>
8	GROMMET	2	<a href="#">388090</a>	<a href="#">388090</a>
~	LABEL - PRODUCT SET-UP GUIDE <b>(NOT SHOWN)</b>	1	1122196	1122196
~	LABEL - ERROR CODE MAP <b>(NOT SHOWN)</b>	1	1111465	1111465
~	LABEL - PROGRAMMING VEC 9.2 <b>(NOT SHOWN)</b>	1	1111244	1111244
~	LABEL - WIRING DIAGRAM <b>(NOT SHOWN)</b>	1	1122839	1122839
~	LABEL - CONFIGURATION MAP <b>(NOT SHOWN)</b>	1	1111457	1111457
~	LABEL - SPACE TO SALES <b>(NOT SHOWN)</b>	1	1123367	1123367
~	SEAL - INNER DOOR <b>(NOT SHOWN)</b>	1	<a href="#">1075678-1</a>	<a href="#">1075678</a>

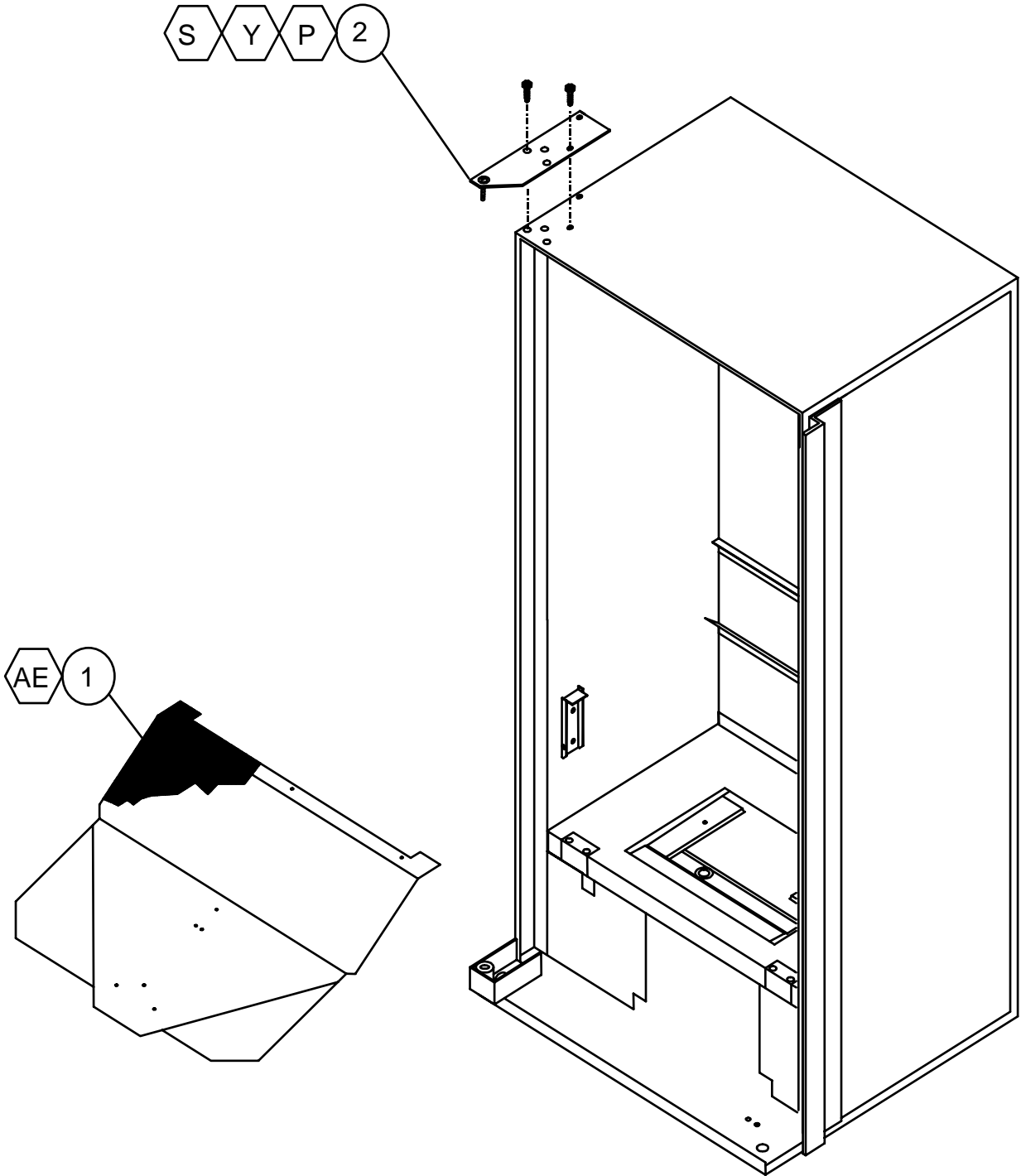



**MARKETING VENDOR COCA-COLA CABINET ASSEMBLY**

ITEM NO.	DESCRIPTION	QTY REQ	PART NO.
1	PRODUCT CHUTE ASSEMBLY	1	2008643-03
2	TOP HINGE - RED	1	2000805-000



# NOTES



# V-MAX

**PARTS SECTION  
MINI V-MAX  
COCA - COLA**

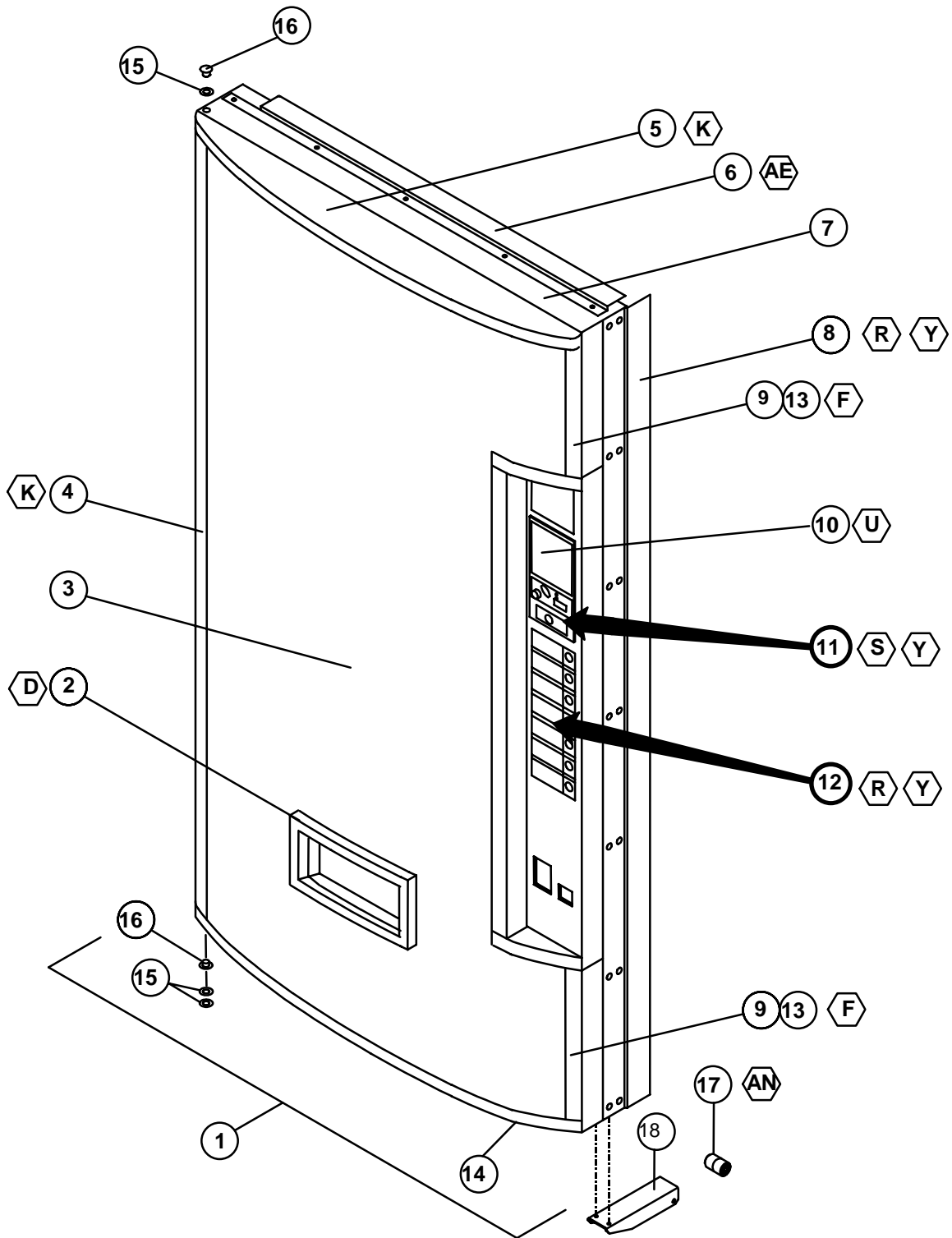



**MINI V-MAX COCA-COLA MAIN DOOR**

ITEM	MODEL NUMBER	576	
NO.	DESCRIPTION	QTY REQ	PART NO.
1	OUTER DOOR - 7-SELECT	1	*
2	EYELET TRIM	1	<a href="#">388271</a>
3	SIGN FACE	1	**
4	SIGN TRIM - LEFT	1	388125-2B
5	SIGN CAP - UPPER	1	388122
6	RAIN GUARD	1	2001031
7	DOOR FRAME WELD	1	1121226
8	DOOR GUARD	1	<a href="#">2010131</a>
9	SIGN TRIM RIGHT	2	1084538
10	DBV PLUG	1	2001228
11	LOCK ASSEMBLY (SEE PAGES SCC-8 - SCC-9)	1	~
12	SELECTION PANEL (SEE PAGES SCC-6 - SCC-7)	1	~
13	SIGN TRIM RETAINER	2	<a href="#">1084589</a>
14	SIGN CAP BOTTOM	1	1084988
15	FLAT WASHER 3/8" (AD)	3	V801491
16	BUSHING	2	<a href="#">388094</a>
17	ROLLER	1	<a href="#">1120388</a>
18	ROLLER BRACKET	1	1120552

\*NOTE: WHEN ORDERING DOOR ASSEMBLY. PLEASE PROVIDE **9-CODE** OR **11-CODE** AND **MANUFACTURER'S DATE CODE**.

\*\*NOTE: WHEN ORDERING SIGN FACE, PLEASE PROVIDE **STYLE**.

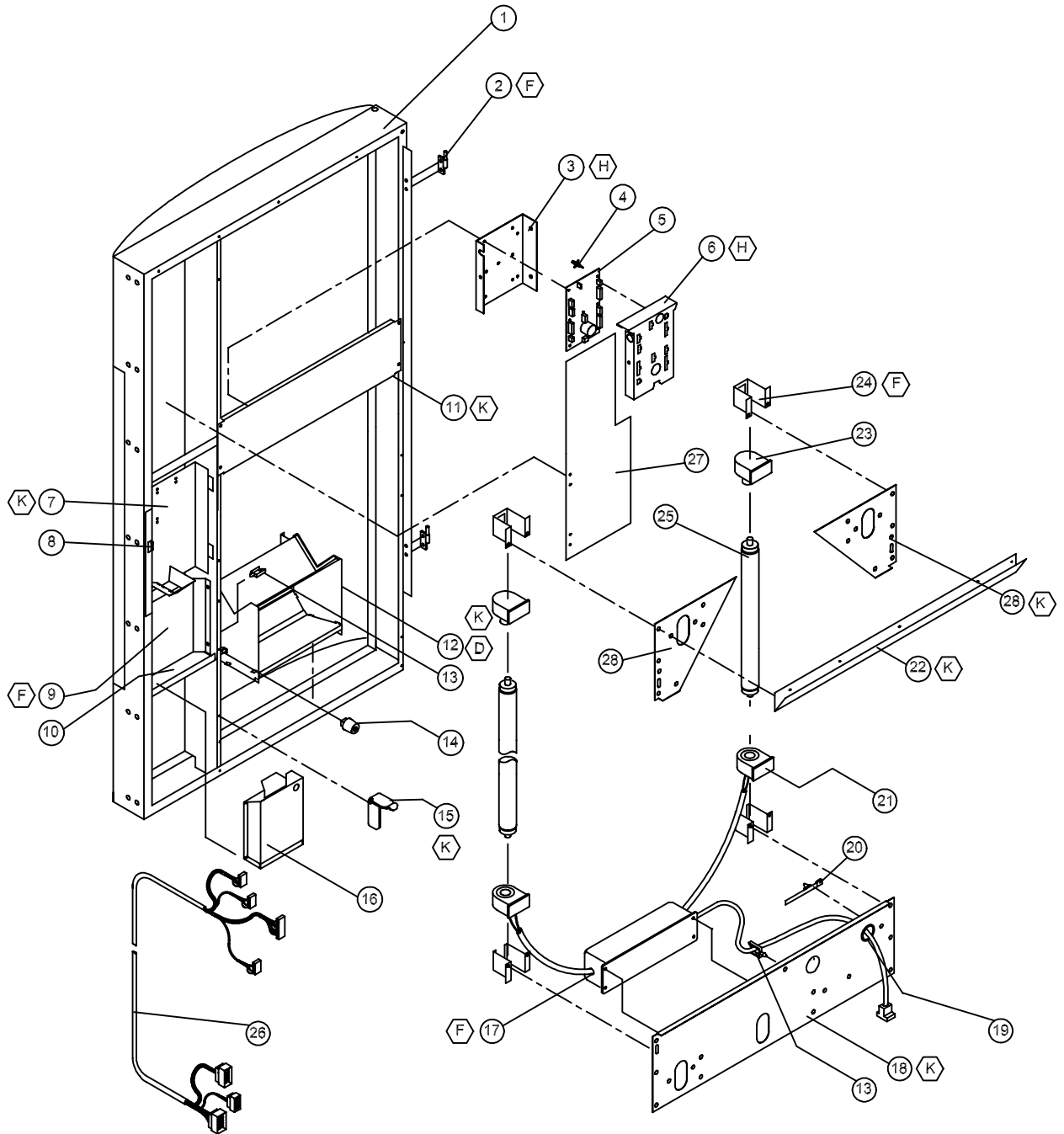



### MINI V-MAX COCA-COLA MAIN DOOR

ITEM	MODEL NUMBER	576	
NO.	DESCRIPTION	QTY REQ	PART NO.
1	DOOR WELD - 72"	1	1121226
2	HINGE - INNER DOOR, MALE	2	<a href="#">1121287</a>
3	MOUNTING BRACKET - CONTROLLER	1	<a href="#">1077716</a>
4	STAND OFF	7	<a href="#">1121740</a>
5	PCBA VEC 9.2 CONTROLLER	1	1110538-38
6	COVER PANEL	1	1077724
7	COIN DOOR ASSEMBLY	1	1081112
8	LATCH - COINAGE DOOR	1	<a href="#">1085546</a>
9	BARRIER PANEL	1	1117147
10	BULKHEAD COIN BOX SUPPORT	1	1112155
11	SHEAR PANEL - MIDDLE	1	1120713-1
12	DELIVERY HOPPER	1	<a href="#">133574-10</a>
13	HARNESS CLIP	5	<a href="#">384692-2</a>
14	DOOR BUMPER	2	1036912
15	RAMP/CATCH - INNER DOOR	1	<a href="#">1121714</a>
16	COIN BOX	1	133563
17	BALLAST 115V- HO	1	388405
18	SHEAR PANEL - LOWER	1	389624
19	GROMMET 3/2"	1	327021
20	HARNESS TIE	2	<a href="#">1088864</a>
21	LAMP HOLDER - FIXED	2	<a href="#">388406</a>
22	RAIN GUTTER	1	<a href="#">1121204</a>
23	LAMP HOLDER - PLUNGER	2	<a href="#">388407</a>
24	BRACKET - LAMPHOLDER	4	<a href="#">1122305</a>
25	LAMP - 64"	2	388408-1
26	DOOR HARNESS	1	<a href="#">1077686</a>
27	DBV GUARD ASSEMBLY (OPTIONAL)	1	1089694
28	SAIL PANEL	2	388774
29	RAIN CURTAIN BALLAST (NOT SHOWN)	1	1121838

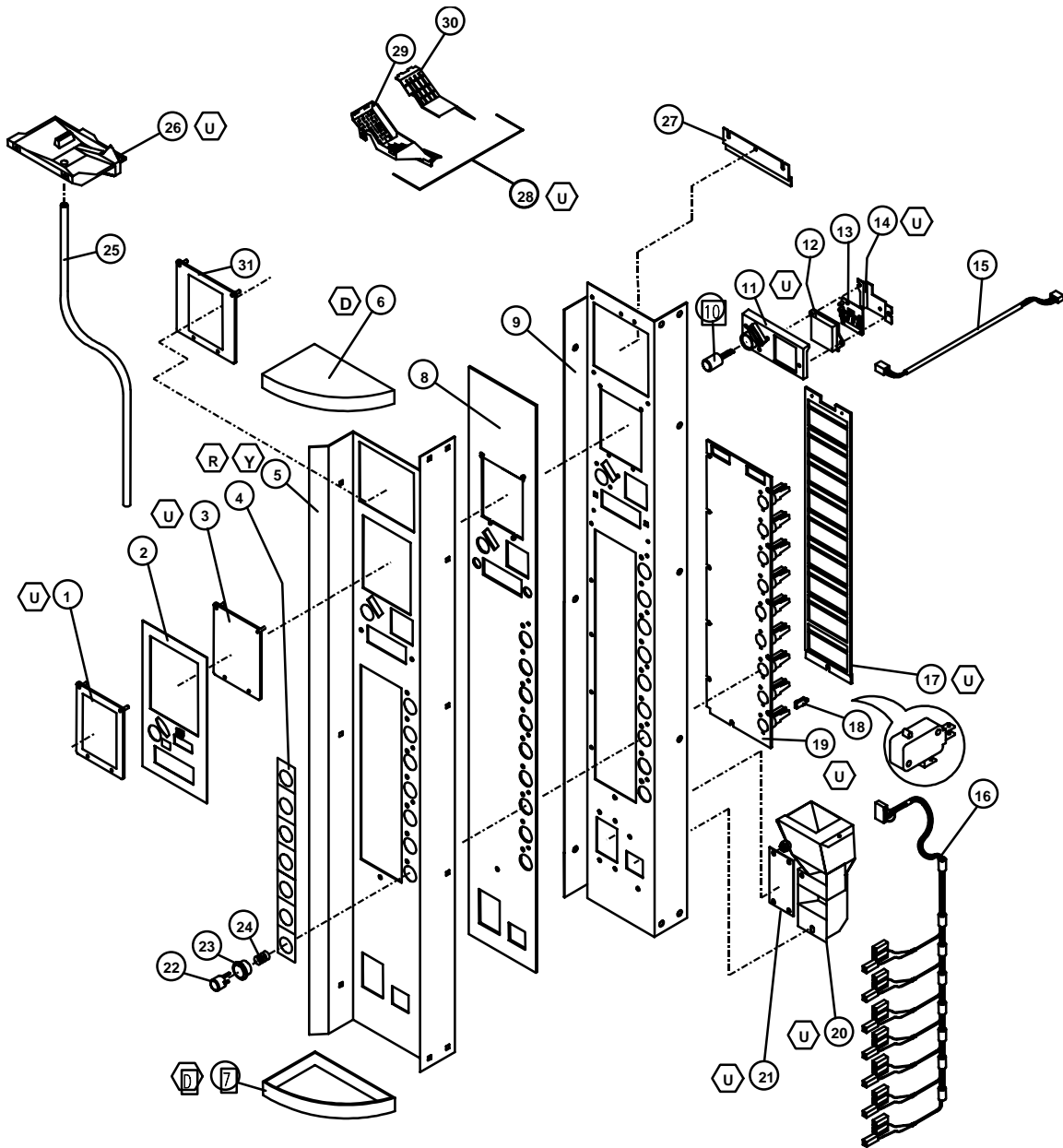



### MINI V-MAX COCA-COLA SELECTION PANEL

ITEM	MODEL NUMBER	576	
NO.	DESCRIPTION	QTY REQ	PART NO.
~	SELECTION PANEL ASSY.	1	1112643-04
1	DBV COLLAR	1	<a href="#">2001201</a>
2	COIN INSERT - DECAL	1	<a href="#">1044885</a>
3	PLUG - DBV	1	2001228
4	DECORATIVE PANEL - 7-SELECT	1	1029576-7
5	OVERLAY PANEL - 7-SELECT	1	2010107
6	PANEL CAP - TOP	1	<a href="#">388139</a>
7	PANEL CAP - BOTTOM	1	<a href="#">388140</a>
8	COVER PANEL	1	1122419
9	SELECTION PANEL	1	2001716
10	BUTTON - COIN RETURN	1	<a href="#">1050473</a>
11	GUIDE PLATE - COIN INSERT/RETURN	1	1050481
12	LENS - DISPLAY	1	1039652
13	PCB - DIGITAL DISPLAY - ELECTRONIC	1	1089678
14	DISPLAY HARNESS	1	1111252
15	SELECTION HARNESS - 7-SELECT	1	1117864
16	CARRIER STRIP ASSEMBLY	1	1017845
17	SWITCH SELECTION	7	<a href="#">368299</a>
18	SWITCH MOUNT	1	1120827
19	COIN RETURN CUP ASSEMBLY	1	<a href="#">1079546</a>
20	CROWN PULLER PLUG	1	1044737
21	BUTTON SELECTION	7	<a href="#">1016741</a>
22	BUTTON HOUSING (BUSHING)	7	1016768
23	SPRING SELECTION	7	<a href="#">1029959</a>
24	DRAIN TUBING	1	<a href="#">1110619</a>
25	TRAY WATER COLLECTION	1	<a href="#">1110562</a>
26	RETAINER - POS LABEL	2	1110155
27	COIN CHUTE ASSEMBLY	1	<a href="#">1087961</a>
28	COIN CHUTE	1	<a href="#">1002333</a>
29	COVER CHUTE	1	<a href="#">1002341</a>
30	BRACKET - DBV (POS) <b>(OPTIONAL)</b>	1	1089716
31	MDB HARNESS <b>(NOT SHOWN)</b>	1	1089341
32	POS BACKING PLATE <b>(NOT SHOWN)</b>	1	1122389

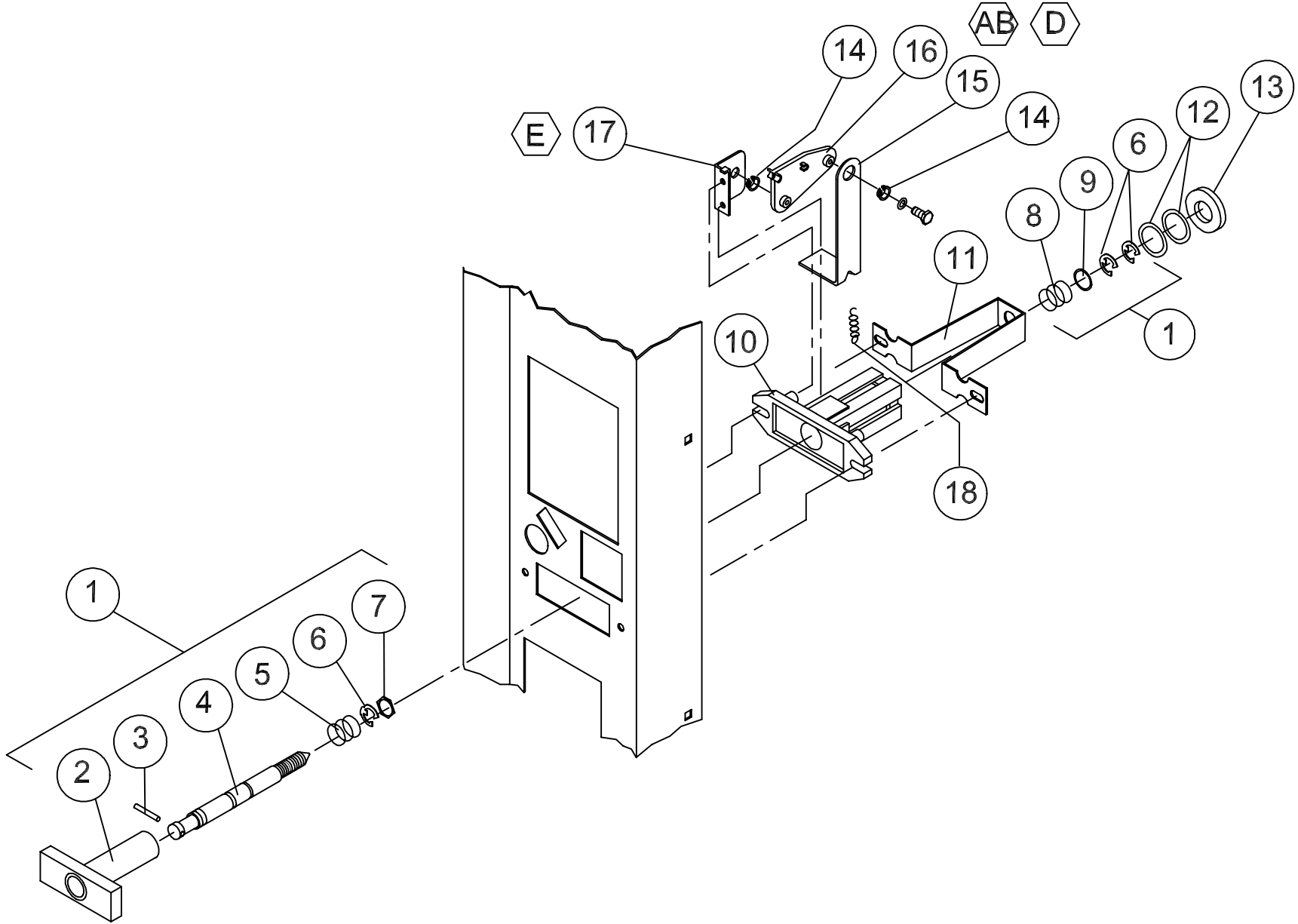



### MINI V-MAX COCA-COLA LOCK ASSEMBLY

ITEM NO.	DESCRIPTION	QTY REQ	PART NO.
1	T-HANDLE LOCK ASSEMBLY	1	<a href="#">1002635</a>
2	T-HANDLE	1	<a href="#">1002392</a>
3	PIN - STUD	1	387601
4	LOCK STUD - QUICKER LOCK	1	<a href="#">1049724</a>
5	SPRING	1	1111554
6	E-RING RETAINER	3	<a href="#">388589</a>
7	HEX WASHER	1	387600
8	SPRING - HEAVY	1	<a href="#">389690</a>
9	FLAT WASHER	1	387718
10	FLANGE	1	<a href="#">1002384</a>
11	LOCK STUD COVER	1	1122126
12	WASHER 1/2"	2	<a href="#">V801023</a>
13	VAPOR SEAL	1	<a href="#">388132</a>
14	BUSHING (BEARING MECH)	2	<a href="#">385603-4</a>
15	LEVER - COIN RETURN	1	<a href="#">1052619</a>
16	CRANK - COIN RETURN LEVER	1	<a href="#">1002244</a>
17	PIVOT BRACKET - COIN RETURN	1	<a href="#">1002252</a>
18	SPRING - COIN RETURN LEVER	1	<a href="#">1060023</a>



# NOTES



**V-MAX**

**ROBO - DOOR  
COCA-COLA**

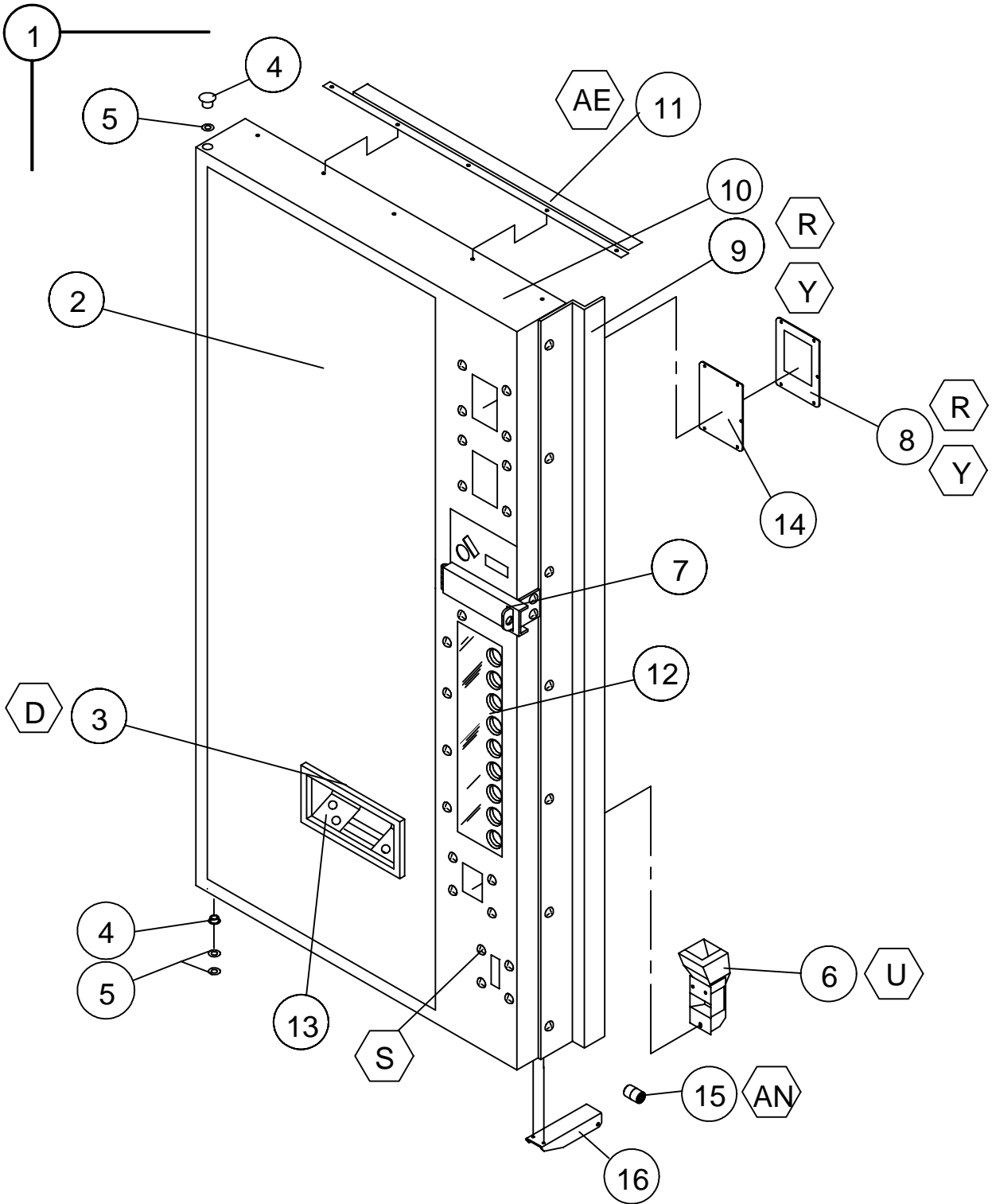



### V-MAX COCA-COLA ROBO DOOR

ITEM NO.	DESCRIPTION	MODEL NUMBER	720	840
			PART NO.	PART NO.
1*	OUTER DOOR - 9 SELECT		1112619-13	1112627-11
2	SIGN FACE DECAL		**	**
3	EYELET TRIM		<a href="#">387125</a>	<a href="#">387125</a>
4	BUSHING		<a href="#">388094</a>	<a href="#">388094</a>
5	FLAT WASHER 3/8" (AD)		V801491	V801491
6	COIN CUP ASSEMBLY		<a href="#">1079546</a>	<a href="#">1079546</a>
7	LOCK COVER ASSEMBLY		2006724	2006724
8	DBV BEZEL		2006626	2006626
9	DOOR GUARD		1122152	1122153
10	DOOR WELD		1121230	1121231
11	RAIN GUARD		<a href="#">2000848</a>	<a href="#">2000848</a>
12	LEXAN PANEL		1086902-1	1086902-1
13	HOPPER GUARD		1075708	1075708
14	DBV PLUG		1037552	1037552
15	ROLLER		<a href="#">1120388</a>	<a href="#">1120388</a>
16	ROLLER BRACKET		1120552	1120522
17	DBV GASKET (NOT SHOWN)		<a href="#">1086759</a>	<a href="#">1086759</a>

FOR T-HANDLE ASSEMBLY, PLEASE SEE PAGE CC-8 & CC-9.

\*NOTE: WHEN ORDERING DOOR ASSEMBLY. PLEASE PROVIDE **9-CODE** OR **11-CODE** AND **MANUFACTURER'S DATE CODE**.

\*\*NOTE: WHEN ORDERING SIGN FACE DECAL, PLEASE PROVIDE **STYLE**.

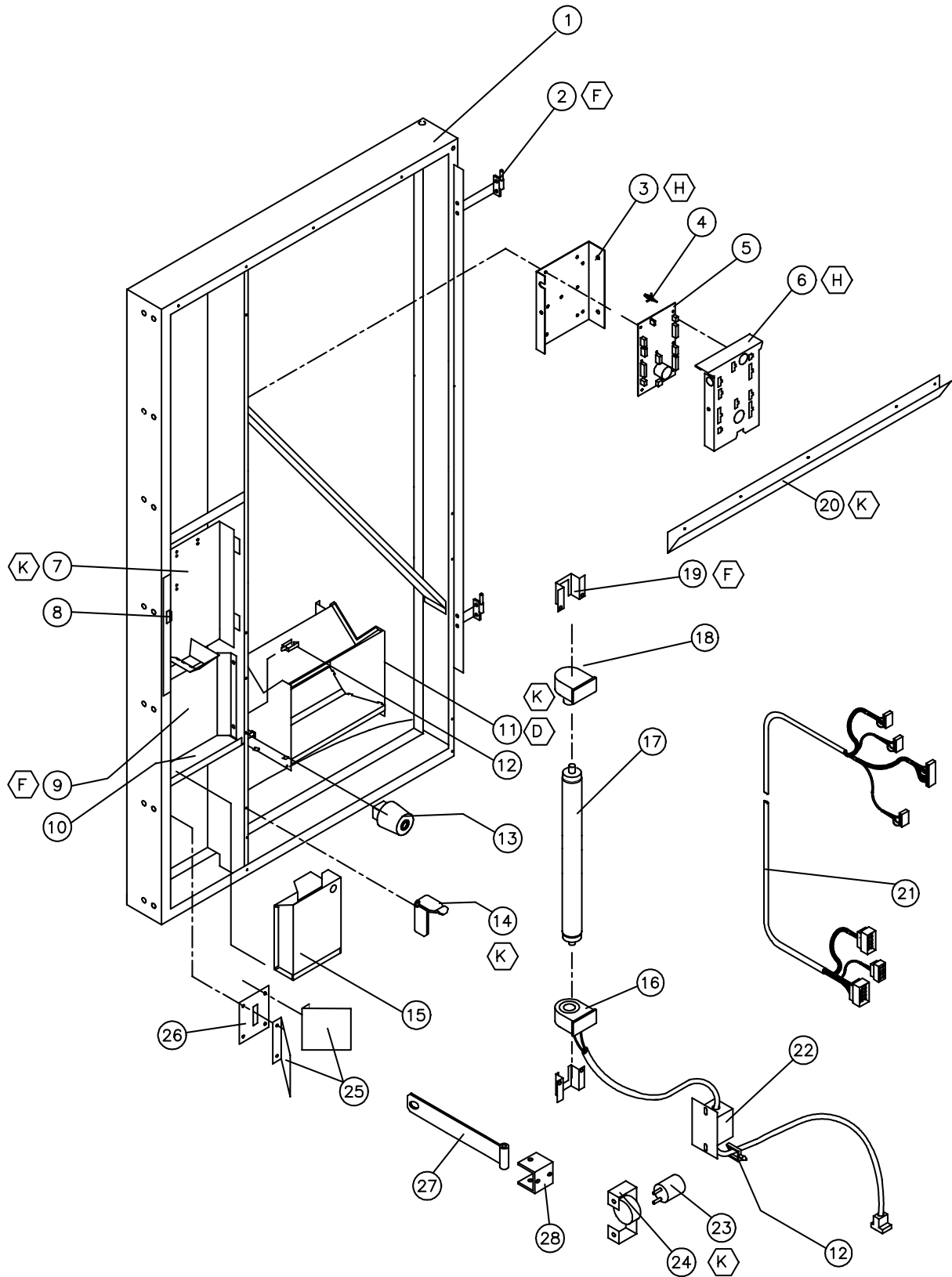



### V-MAX COCA-COLA ROBO DOOR

ITEM NO.	DESCRIPTION	MODEL NUMBER	720/840
		QTY REQ	PART NO.
1	DOOR WELD - 72"	1	1121230
~	DOOR WELD - 79"	1	1121231
2	HINGE MALE - INNER DOOR	2	<a href="#">1121287</a>
3	MOUNTING BRACKET - CONTROLLER	1	<a href="#">1077716</a>
4	STAND OFF	7	<a href="#">1121740</a>
5	PCBA VEC 9.2 CONTROLLER	1	1110538-38
6	COVER PANEL	1	1077724
7	COIN DOOR ASSEMBLY	1	1081112
8	LATCH - COINAGE DOOR	1	<a href="#">1085546</a>
9	BARRIER PANEL	1	1117147
10	BULKHEAD COIN BOX SUPPORT	1	1112155
11	DELIVERY HOPPER ASSEMBLY	1	<a href="#">133574</a>
12	HARNESS CLIP	5	<a href="#">384692-2</a>
13	DOOR BUMPER	2	1036912
14	RAMP/CATCH - INNER DOOR	1	<a href="#">1121714</a>
15	COIN BOX	1	133563
16	LAMP HOLDER – FIXED - OPTIONAL	1	388531
17	LAMP - 20" - OPTIONAL	1	332974
18	LAMP HOLDER – PLUNGER - OPTIONAL	1	388532
19	BRACKET - LAMP HOLDER - OPTIONAL	2	1086929
20	RAIN GUTTER	1	1122404
21	DOOR HARNESS	1	<a href="#">1077686</a>
22	BALLAST	1	321345-3
23	STARTER	1	321350
24	SOCKET - STARTER	1	327675-2
25	HASP - GUIDE	2	1019104
26	REINFORCEMENT HASP PLATE	1	1019147
27	HASP WELD ASSEMBLY	1	2006676
28	HASP BRACKET	1	2010136
29	MDB HARNESS ( <b>NOT SHOWN</b> )	1	1089341

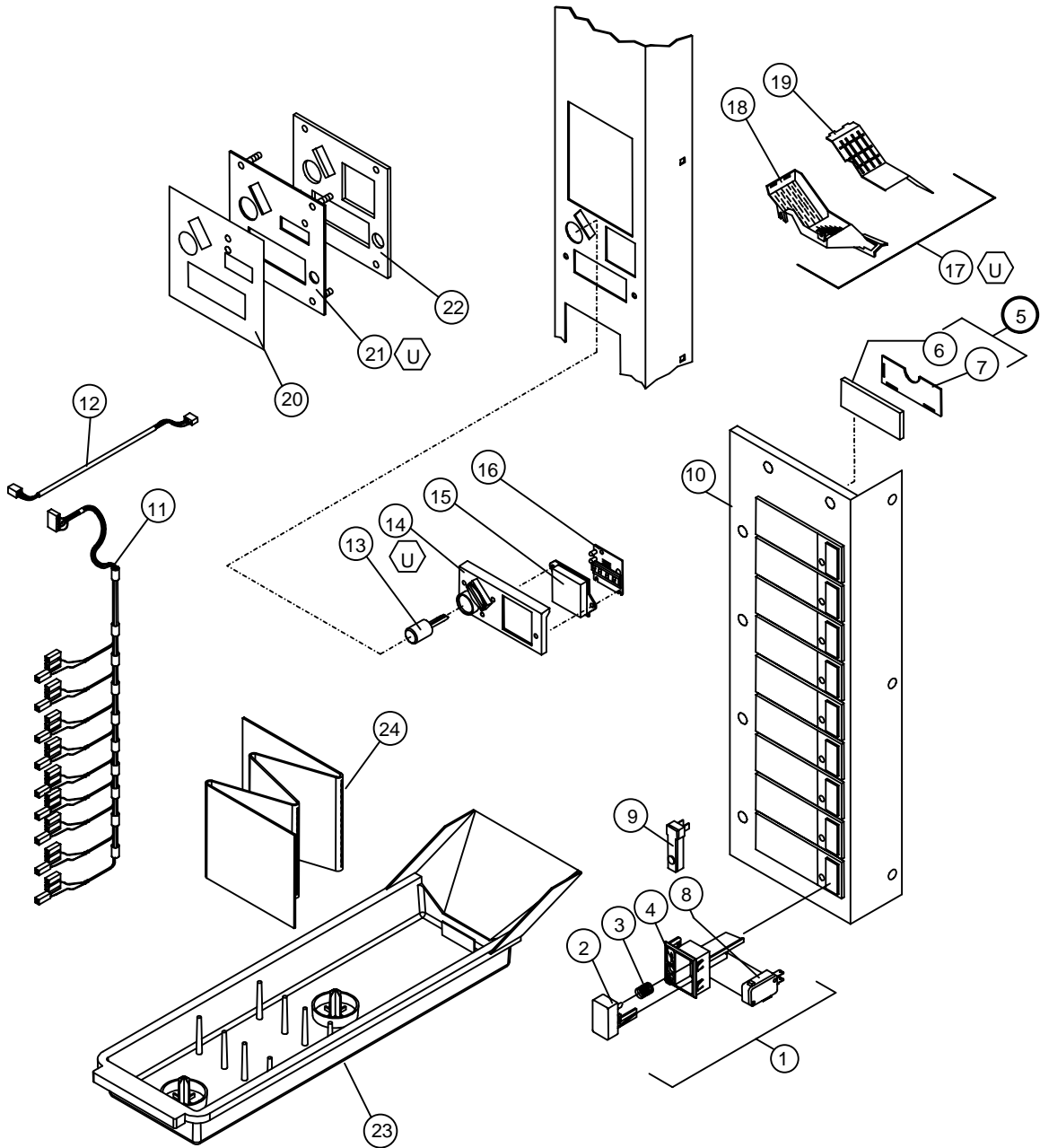



### V-MAX COCA-COLA ROBO DOOR SELECTION PANEL

ITEM NO.	DESCRIPTION	QTY REQ	PART NO.
1	BUTTON ASSEMBLY	9	1036203
2	SELECTION BUTTON - GRAY	1	<a href="#">1116775</a>
3	SPRING SELECTION	1	<a href="#">388858</a>
4	BUTTON HOUSING	1	<a href="#">1006932</a>
5	SELECTION SWITCH	1	<a href="#">368299</a>
6	SOLDOUT PLUG	1	<a href="#">1006975</a>
7	SELECTION WINDOW ASSEMBLY	1	<a href="#">133431</a>
8	SELECTION WINDOW	1	<a href="#">388223</a>
9	SELECTION WINDOW - BACK	1	<a href="#">388116</a>
10	SELECTION PANEL - 9-SELECT	1	2010092
11	SELECTION HARNESS - 9-SELECT	1	1111279
12	DISPLAY HARNESS	1	1111252
13	BUTTON - COIN RETURN	1	<a href="#">1050473</a>
14	GUIDE PLATE - COIN INSERT/RETURN	1	1050481
15	LENS - DISPLAY	1	1039652
16	PCB DIGITAL DISPLAY - ELECTRONIC	1	1089678
17	COIN CHUTE ASSEMBLY	1	<a href="#">1087961</a>
18	COIN CHUTE	1	<a href="#">1002333</a>
19	COIN CHUTE COVER	1	<a href="#">1002341</a>
20	COIN INSERT DECAL <b>(OPTIONAL)</b>	1	<a href="#">1044907-5</a>
21	COVER PLATE - COIN INSERT - PLAIN	1	2001503
22	SECURITY PLATE - COIN INSERT	1	<a href="#">2001732</a>
23	WATER COLLECTION TRAY	1	<a href="#">1110562</a>
24	DRAIN TUBE	1	<a href="#">1110619</a>



## NOTES



# **V-MAX**

## **MAINTENANCE SECTION**



## MAINTENANCE

The following section is a basic guide for general maintenance and servicing of the vendor. This section is divided into three parts: (I) Preventative Maintenance, (II) Lubrication Guide, and (III) Care and Cleaning.

### I. PREVENTATIVE MAINTENANCE SUGGESTIONS:

Whenever a vendor is visited on its site, the following service should be performed. Preventative maintenance will help prevent future problems with the vendor.

- A. Observe the vendor and its surrounding area for any unusual indications of problems (rear of cabinet, obstructions of the air flow, dark spots on the sign face, etc.).
- B. Open the door and visually check the inside of the vendor (water accumulation, rust marks, moisture around the edges of the inner door, etc.).
- C. Check the fluorescent lamps, replace as necessary. Replace all lamps within 24 to 48 hours of burnout. This will prevent damage to the ballast.
- D. Check the product temperature for proper cooling.
- E. Check evaporator drain for obstruction; water in the evaporator area must drain to the condensation pan.
- F. Empty condensation pan.
- G. Clean the condenser, free vanes of dirt, lint, etc.
- H. Check that evaporator fan(s) run normally.
- I. Check that the compressor and condenser fan run normally.
- J. Investigate any unusual sounds (fan blades hitting something, refrigeration lines rattling, etc.).
- K. Clean coin acceptor.
- L. Deposit all coinage accepted by the vendor to check for proper operation of the coinage mechanism.
- M. Test the vendor and make a report on the problems.

### II. LUBRICATION GUIDE:

Lubricate indicated areas as directed on the chart below.

INTERVALS	PARTS	LUBRICANT
Every six months	Top door hinge, hinge pin at the base of cabinet, door latch cam to cabinet strike, T-handle shaft & latch.	Grade two, high low temperature grease
As necessary	Pivot area of bucket and gate	Grade two, high low temperature grease



### III. CARE AND CLEANING

**DO NOT USE WATER JET FOR CLEANING.**

**AVOID USING WATER OR ANY OTHER LIQUIDS NEAR ELECTRONIC COMPONENTS**

- A. **GENERAL PROCEDURE (painted metal areas)**  
Wash vendor with soap and water. The exterior may be waxed with any good automobile wax.
- B. **FRESH PAINT SPLASHES, GREASE, GLAZING COMPOUND REMOVAL**  
Before drying, these elements may be removed by rubbing lightly with grade "A" Naptha (or equivalent grade solvent). After removal, use general cleaning procedure (listed above in A).
- C. **LABELS AND STICKER REMOVAL**  
Use Kerosene, VM&P grade Naptha or petroleum spirits for removal. When the label material does not allow penetration of solvent (such as vinyl), the application of heat (hair blow dryer) will soften the adhesive and promote removal. **CAUTION:** Excessive heat can cause surface damage. After the label is removed, use the general cleaning procedure (listed above in A).
- D. **SCRATCH REMOVAL**  
Remove or minimize hairline scratches and minor abrasions by using any good quality automobile polish. Test product before using.
- E. **LEXAN SIGNS**  
To clean Lexan sign faces the following procedure is recommended.
  - 1. Wash sign with mild soap or detergent and lukewarm water.
  - 2. Using a soft cloth or sponge, gently wash the sign. **DO NOT SCRUB!**
  - 3. Rinse well with clean lukewarm water.
  - 4. Dry thoroughly with a chamois or cellulose sponge (to prevent water spotting). **DO NOT USE SQUEEGEE!****NOTE:** Most organic solvents, petroleum, spirits, or alcohol are **NOT** compatible cleaning materials for Lexan signs. Usage of those materials could permanently damage the sign.
- F. **REFRIGERATION AREA**  
The condenser and evaporator must be kept clean for efficient operation. Be sure all vanes and tubing are clean and clear of obstruction; this allows free passage of air. Clean with a brush, a vacuum cleaner or compressed air. Keep cabinet drain open; clean as necessary.



## **REFRIGERATION OPERATION**

The refrigeration operation section is divided into three areas: Basic Refrigeration Principle, Detailed Vending Machine Refrigeration Cycle, and Parts Description.

### **BASIC REFRIGERATION PRINCIPLE**

What a refrigeration system really accomplishes is the transfer of heat. A refrigeration system removes the excess heat from a refrigerated area and then transfers it to a condenser where it is dissipated. As heat is removed, the refrigerated area cools.

In vending machines, large quantities of the heat must be transferred rapidly, economically and efficiently. This process must be able to withstand continuous repetition, without loss of refrigerant, over an extended period. The most common system used in the vending industry is the vapor compression (or simple compression) cycle system. It consists of four basic elements: An evaporator, a compressor, a condenser, and a pressure-reducing device (all part of a sealed system).

The compression system operates at two pressure levels: The low evaporating pressure and the high condensing pressure. The refrigerant acts as the transport medium, in which heat is moved from the evaporator to the condenser; at the condenser, the heat is dissipated into the surrounding air.

The liquid refrigerant changes from a liquid to a vapor and back to a liquid again. This change of state allows the refrigerant to absorb, and rapidly discharge, large quantities of heat efficiently.

#### **BASIC VAPOR COMPRESSION SYSTEM CYCLE:**

In the evaporator the liquid refrigerant vaporizes. This change occurs at a temperature low enough to absorb heat from the refrigerated space. The temperature of vaporization is controlled by the pressure maintained in the evaporator (the higher the pressure, the higher the vaporization point).

The compressor pumps the vapor from the evaporator, through the suction line, and to the condenser. The compressor takes the low pressure vapor and compresses it, increasing both the pressure and the temperature. The compressor pumps the vapor at a rate rapid enough to maintain the ideal pressure. The hot high pressure vapor is forced out of the compressor, into the discharge line and then into the condenser.

Air is blown through the condenser, allowing heat to transfer from the condenser and into the passing air. As the heat is removed, the stored refrigerant is condensed into a liquid. The liquid refrigerant is stored in the lower tube of the condenser. This is where it flows through the capillary tube back into the evaporator, where the refrigeration cycle is repeated.



## **DETAILED REFRIGERATION CYCLE**

The following is a detailed refrigeration cycle as it applies to the refrigeration system installed in Vendo equipment. (Refer to the flow chart in Figure 1.)

As the air temperature in the cabinet rises, the electronic temperature sensor reports the air temperature to the electronic controller. The electronic controller actuates the refrigeration control relay which turns on both the compressor and condenser fan motor.

The evaporator fan pulls air from the front of the refrigerated space of the cabinet. It pulls the air through the evaporator, and blows it up the back of the vend stack. (The evaporator fan runs continuously.) As the air passes through the evaporator, heat is drawn from the air and transferred to the liquid refrigerant. As the cooled air circulates through the vend stack, heat is drawn from the product and transferred to the circulating air. The heated air is again drawn through the evaporator where the heat is removed.

In the evaporator, the liquid refrigerant draws heat from the circulating air. As refrigerant receives heat, it vaporizes.

The compressor pumps the vapor from the evaporator and compresses it, increasing both pressure and temperature. The compressor forces the compressed vapor out, through the discharge line and into the condenser.

The condenser fan pulls air through the condenser. As the hot refrigerant vapor passes through the condenser tubes, heat is drawn from the vapor. This heat is dissipated into the passing air. The air then exits out the back of the vendor. As the refrigerant vapor in the condenser lines is cooled, it returns to a liquid state.

From the condenser the liquid flows to the drier. The drier removes any water and solid particles from the liquid refrigerant.

The cooled liquid refrigerant continues from the drier, through the capillary tube, to the evaporator. The capillary tube steadies the flow rate of the refrigerant. Its small inside diameter allows the pressure in the evaporator to remain low while the pressure in the condenser is high.

The cool refrigerant in the evaporator draws heat from the circulating air in the cabinet. As the temperature in the cabinet drops, the electronic temperature sensor reports the air temperature to the electronic controller. The electronic controller deactivates the refrigeration control relay which turns off the compressor and condenser fan motor.

When the air temperature in the cabinet rises above the electronic controller's cut in setting, the compressor and the condenser fan engage again.

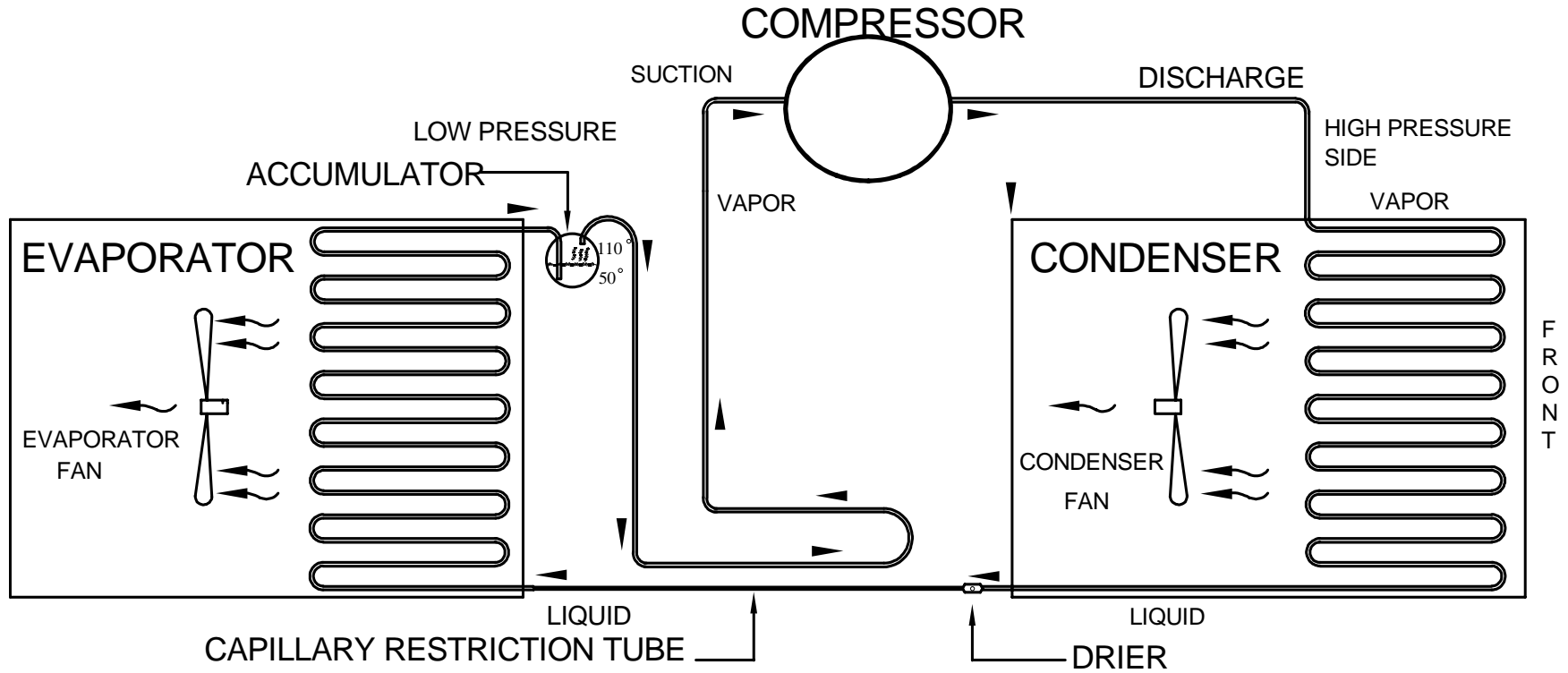

FIGURE 1



## REFRIGERATION PARTS DESCRIPTION

The compressor, condenser, drier, capillary tube, evaporator, and accumulator are part of a sealed system (refer to Figure 2). These items are not available separately.

### COMPRESSOR

The compressor takes in low pressure vapor and compresses it, increasing both the pressure and the temperature. The hot high pressure gas is forced out to the condenser. The compressor and the motor that drives the compressor are sealed inside a housing. The compressor, as a unit, is mounted on the refrigeration base. The base is mounted in the bottom of the vendor, outside the sealed refrigeration space.

### CONDENSER

The condenser takes heat out of the high pressure vapor that it receives from the compressor. As the vapor passes through the condenser it cools and returns to a liquid state. The condenser is mounted to the refrigeration base near the front of the vendor. It is easily accessible for cleaning.

### DRIER

The drier is a molecular sieve strainer drier. It removes water and solid particles from refrigerant liquid. One side of the drier is connected to the outlet line of the condenser; the other side is connected to the capillary tube going to the evaporator.

### CAPILLARY TUBE

The capillary tube controls, at a steady rate, the flow of refrigerant liquid to the evaporator. It has a very small inside diameter to keep pressure in the evaporator low while the pressure in the condenser is high. It is the connecting link between the condenser and evaporator.

### EVAPORATOR

The evaporator is a heat transference device. It removes the heat from the air in a refrigerated space and transfers it to the refrigerant liquid. This liquid evaporates into a vapor and is removed by the compressor. The evaporator is mounted inside the refrigerated space of the cabinet, directly below the delivery chute.

### ACCUMULATOR

The accumulator traps any refrigerant liquid, which did not boil off into a vapor before reaching the compressor. The accumulator allows the refrigerant liquid to boil off as a vapor (preventing damage to the compressor). It also prevents suction line sweating. The accumulator is mounted in the suction line on the outline side of the evaporator.

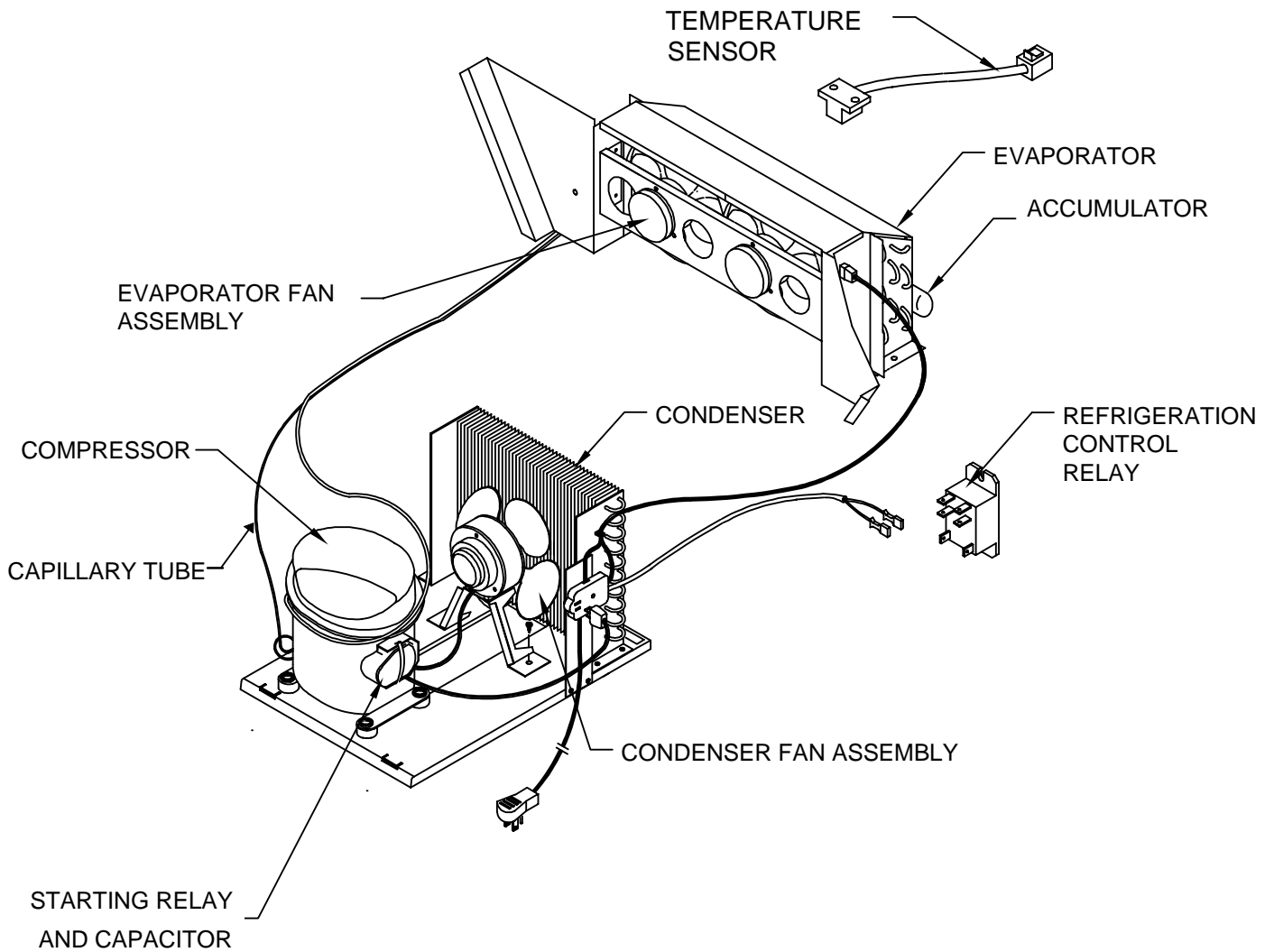

**FIGURE 2**



The parts listed below are not part of the sealed refrigeration system and are available separately.

**START CAPACITOR - P/N: 1112805**

The start capacitor is used to increase power during the start. This additional power will help get the compressor running in case there is any back pressure.

**STARTING RELAY – INCLUDED IN ASSEMBLY P/N [513506066](#)**

The starting relay is mounted in the terminal box on the outside of the compressor under the housing. When the compressor first starts up, the starting relay closes and completes a starting circuit. When the compressor motor reaches operating speed, the starting relay opens and breaks the starting circuit.

**THERMAL OVERLOAD SWITCH – INCLUDED IN ASSEMBLY P/N [513506066](#)**

The thermal overload switch is mounted in the terminal box on the outside of the compressor under the housing. If the compressor motor gets hot or draws too much current, the thermal overload opens and breaks the starting and running circuit of the motor. As the motor cools, the thermal overload closes, allowing the compressor to resist.

**REFRIGERATION CONTROL RELAY - P/N: [1079724](#)**

The refrigeration control relay is mounted behind the left side air dam. This relay controls the compressor and condenser fan motor via the electronic control board.

**TEMPERATURE SENSOR - P/N: [1079716](#)**

The temperature sensor is mounted in the inlet airflow of the evaporator. This sensor monitors the air temperature and reports it to the electronic controller so that the controller can operate the refrigeration system via the refrigeration control relay.



## NOTES



# **V-MAX**

## **TROUBLESHOOTING**



## VENDO WARRANTY

*For V-Max Equipment Purchased prior to 10/1/01*

### NEW EQUIPMENT

- I. This is a Limited Warranty.
- II. The Vendo Company warrants, to the original purchaser, each part of each new vending machine for a period of fifteen (15) months from the date of shipment, to be free from defects in material and workmanship. This Warranty DOES NOT include light bulbs, fluorescent tubes, fuses, finish, or operating supplies.
- III. In addition to the fifteen (15) month Warranty on each part of each new vending machine, the hermetically-sealed refrigeration system used in machines designed to vend bottles, cans, and aseptic cartons is warranted to be free from defects in materials and workmanship for an additional four (4) years, provided the hermetically-sealed portion of the system has not been opened or damaged. Hermetically-sealed refrigeration systems DO NOT include fan motors, temperature controls, capacitors, overload switches or starting relays which are covered by the fifteen (15) month Warranty.
- IV. Electronic control boards and the LED display are warranted against defects in material and workmanship for an additional two (2) years. The Company, at its option, will either repair or replace products that prove to be defective.
- V. To qualify for Warranty replacement, all requests for returns must be made in writing within the warranty period, accompanied by a record of the cabinet model and serial number. If a return is found to be inoperative due to defects in material and/or workmanship, we will, at our option, make necessary repairs or furnish a reconditioned or new replacement part or refrigeration system at no charge.
- VI. The Vendo Company will pay normal transportation charges on parts and refrigeration system replaced under this Warranty. If special handling or premium transportation is requested, these charges are assumed by the purchaser.
- VII. Any parts and/or refrigeration systems replaced during the warranty period are warranted for the remaining time on the original warranty.
- VIII. This Warranty DOES NOT apply to machines located outside the United States and Canada, reconditioned equipment, equipment sold "as is", or components designed to work on electric currents other than 110v/120v 60hz cycle or 208v/220v 50hz cycle, as specified on the serial tag.
- IX. Title and risk of loss pass to the purchaser on delivery of the vending machine, replacement parts and/or refrigeration system to the common carrier. All loss and damage claims are the responsibility of the purchaser and must be filed with the delivering carrier.
- X. This Warranty DOES NOT include any service guarantee, either explicit or implied, nor will it extend to cover incidental or consequential damages or damages resulting from purchaser or third party negligence, accident, vandalism, or an act of God.
- XI. The Vendo Company reserves the right to make design changes, additions to, and improvements upon any of our product without incurring any obligation to incorporate same on any product previously manufactured.
- XII. This Warranty is in lieu of all other express warranties or other obligations or liabilities on our part, and we neither assume nor authorize any person to assume for us, any other obligation for liability in connection with the sale of said machines or parts thereof. **EXCEPT AS SPECIFICALLY PROVIDED HEREIN, THERE ARE NO WARRANTIES GIVEN, EITHER EXPRESS OR IMPLIED, AND ALL OTHER WARRANTIES, INCLUDING SPECIFICALLY BUT WITHOUT LIMITATION WARRANTIES OF MERCHANTABILITY AND FITNESS FOR PARTICULAR PURPOSE, ARE HEREBY EXPRESSLY DISCLAIMED.**

**THE VENDO COMPANY 2/1996**



**THE VENDO COMPANY  
NEW EQUIPMENT WARRANTY  
V-MAX VENDING MACHINES  
United States / Canada**

- I. This warranty benefits only the original purchaser of a new vending machine, and does not benefit any transferee of a new vending machine from the original purchaser.
- II. The Vendo Company warrants each part of each new vending machine for a period of fifteen (15) months from the date of shipment, to be free from defects in material and workmanship. This Warranty DOES NOT include light bulbs, fluorescent tubes, fuses, finish or operating supplies.
- III. The hermetically-sealed refrigeration system used in machines designed to vend bottles, cans, and aseptic cartons is warranted to be free from defects in materials and workmanship for six (6) years, provided the hermetically-sealed portion of the system has not been opened or damaged. This six (6) year warranty DOES NOT include fan motors, temperature controls, capacitors, overload switches or starting relays.
- IV. Electronic control boards, LED displays and Vend motors, are warranted against defects in material and workmanship for five (5) years.
- V. Return authorization is required to qualify for warranty replacement. All requests for returns must be in writing or via phone, within the warranty period, and accompanied by a record of the cabinet model and serial number of the machine. Freight carrier return tickets will only be issued to the machine owner for refrigeration system returns. This warranty is voided when the serial number of a machine is missing. If a return is found to be inoperative due to defects in material and/or workmanship, we will, at our option, make necessary repairs or furnish a reconditioned or new replacement part or refrigeration system at no charge.
- VI. "Return Material Tags" indicating cabinet model, machine serial number and explanation of defect must accompany all returned parts or machines. "Return Material Tags" will be furnished upon request. On-site inspection of defective parts, at The Vendo Company's option, may be used to facilitate credit approval or the replacement of parts.
- VII. The Vendo Company will pay normal transportation charges on refrigeration systems and parts replaced under this warranty. If special handling or premium transportation is requested, those charges will be assumed by the original purchaser.
- VIII. Any parts and/or refrigeration systems replaced during the warranty period are warranted for the remaining time on the original warranty.
- IX. This warranty DOES NOT apply to machines located outside the United States and Canada, reconditioned equipment, equipment sold "as is", or components designed to work on electric currents other than 110v/120hz 60 cycle, as specified on the serial tag.
- X. Title and risk of loss pass to the original purchaser on delivery of the vending machine, replacement parts and/or refrigeration system to the common carrier. All loss and damage claims are the responsibility of the original purchaser and must be filed with the delivering carrier.
- XI. This warranty DOES NOT include any service guarantee, either explicit or implied, nor will it extend to cover incidental or consequential damages resulting from the original purchaser or third party negligence, accident, vandalism, or an act of God.
- XII. The Vendo Company reserves the right to make design changes, additions to, and improvements upon any of our product without incurring any obligation to incorporate same on any product previously manufactured.
- XIII. This warranty is in lieu of all other express warranties or other obligations or liabilities on our part, and we neither assume nor authorize any person to assume for us, any other obligation for liability in connection with the sale of said machines or parts thereof. EXCEPT AS SPECIFICALLY PROVIDED HEREIN, THERE ARE NO WARRANTIES GIVEN, EITHER EXPRESS OR IMPLIED, AND ALL OTHER WARRANTIES, INCLUDING SPECIFICALLY BUT WITHOUT LIMITATION WARRANTIES OF MERCHANTABILITY AND FITNESS FOR PARTICULAR PURPOSE, ARE HEREBY EXPRESSLY DISCLAIMED.



## PARTS RETURN PROCEDURES

1. All parts returned must be accompanied by a material return tags (P/N 1122825) Tag must clearly state the reason for the return and the Return Goods Authorization Number received from your Vendo Customer Service Rep at 1-800-344-7216. (Return tags are available from our parts department upon request).
2. All parts should be properly wrapped and packed securely to avoid further damage.
3. To replace an inoperative part, please use the following instructions
4. Complete the return tag making sure to fill in ALL requested information to ensure prompt processing. Keep top (white) copy for your records. Attach tag to inoperative part and send it by the most inexpensive method of transportation (Federal Express Ground or Overnight Transportation) **To: THE VENDO COMPANY, 4015 EAST RAINES ROAD, MEMPHIS, TENNESSEE 38118.**
5. Be sure to check () the box marked "credit" and to fill in the invoice number covering the part sent to you or check the box marked "replace with like part".
6. If the box is marked for replace with like part, a like part will be shipped at no charge if our inspection shows that the inoperative part became defective during the warranty period.
7. If the box is marked for credit, a credit will be issued to cancel the invoice on which the replacement part was shipped. This credit will include any applicable prepaid transportation charges. To receive credit the inoperative part must be returned within 30 days from the date the replacement was shipped.
8. Vendo does not issue cash credit for the return of any part or accessory.

### **REFRIGERATION UNIT RETURN PROCEDURE**

1. All refrigeration units returned must be accompanied by a material return tag (P/N 1122826). Tag must clearly state the reason for the return and the Return Goods Authorization Number received from your Vendo Customer Service Rep at 1-800-344-7216. (Return tags are available from our parts department upon request).
2. All refrigeration units should be properly wrapped and packed securely to avoid further damage.
3. To replace an inoperative part, please use the following instructions.
4. Complete the return tag making sure to fill in ALL requested information to ensure prompt processing. Keep top (white) copy for your records. Attach tag to inoperative part and send it by the most inexpensive method of transportation (Federal Express Ground or Overnight Transportation) **To: THE VENDO COMPANY 7209 N. INGRAM AVE. FRESNO, CA. 93650**
5. Be sure to check () the box marked "credit" and to fill in the invoice number covering the part sent to you or check the box marked "replace with like part".
6. If the box is marked for replace with like part, a like part will be shipped at no charge if our inspection shows that the inoperative part became defective during the warranty period.
7. If the box is marked for credit, a credit will be issued to cancel the invoice on which the replacement part was shipped. This credit will include any applicable prepaid transportation charges. To receive credit the inoperative part must be returned within 30 days from the date the replacement was shipped.
8. Vendo does not issue cash credit for the return of any refrigeration unit.

**\*Canadian and International customers please contact your Customer Service Representative for return instructions**



## TROUBLESHOOTING GUIDE

This guide is a general list of probable problems, causes, and solutions. For problems not listed or additional questions, contact the Technical Services Department at Vendo, 7209 N. Ingram Ave., Fresno, CA 93650 or call 1-800-344-7216, extension 3368. Please have the manufacturer's date code and model number of the vendor when you call.

The troubleshooting guide is divided into three columns: Possible Problem, Possible Cause, and Service Suggestion.

POSSIBLE PROBLEM	POSSIBLE CAUSE	SERVICE SUGGESTION
Returns all good coins	No power to vendor	Check power supply.
	No power to changer	Check coin mechanism plugs. Check for faulty harness wiring (see wiring diagram for circuit).
	Acceptor is out of adjustment or coin gate is not closed	Check coin mechanism.
	Electronic-CREM function: 1.) No power to acceptor 2.) Defective acceptor	2. Check electrical connections of the acceptor. 2. Replace acceptor.
	Coin paths are dirty	Clean acceptor with approved cleaner. <b><u>DRY</u></b> <b><u>VERY THOROUGHLY.</u></b>



POSSIBLE PROBLEM	POSSIBLE CAUSE	SERVICE SUGGESTION
Money accepted, no product vended	Bad selection switch(es)	Check selection switches, replace as necessary.
	Bad selection switch harness connection	Check harness connection.
	Sold-out switch (of column selected) inoperative	Check switch, replace as necessary.
Vend motor runs until two or three products are vended or vend motors run continuously	Improper cam lobe adjustment	Check cam for proper arrangement of cam lobes (see product set-up guide).
	Motor position switch not making proper contact with cam lobe	Check lever for proper lever positioning and freedom of movement.
Refrigeration unit will not run at all	No power to vendor	Check power supply, also check service cord connections.
	Bad temperature sensor	Check / replace.
	Bad refrigeration relay	Check / replace.
Compressor will not start	Overload Protector inoperative	Check overload (apply insulated jumper across terminal, if compressor starts, replace overload).



POSSIBLE PROBLEM	POSSIBLE CAUSE	SERVICE SUGGESTION
Compressor will not start, condenser fan motor running - unit hot (power to compressor)	Starting relay or capacitor inoperative	Check relay or capacitor, replace.
	Compressor inoperative	Disconnect power to vendor, remove all leads from compressor, check continuity from "common", "start" and "run" to compressor case. If continuity shows, replace compressor. Also check from "common to start" (using continuity or IHMS). If meter fails to show reading replace compressor.
Compressor starts but does not run	Will not cycle	Check overload and contact, replace overload if necessary.
	Starting relay stays closed	Replace relay.
	Compressor motor problem	Check, replace.
Compressor runs but cabinet temperature warm	Loss of refrigerant	Replace refrigeration unit. (Note: Any work of this nature done without express permission from The Vendo Company can void refrigeration unit warranty.)
	Condenser fan not working	Check circuit to run motor. Replace motor. Check for obstruction of fan blade.
	Blocked or dirty condenser  (Refer to initial installation in the service manual)	Check condenser vanes for obstruction, lint or dirt. Clean, also check for proper air flow through refrigeration area.
	Evaporator fan not working	Check circuit to fan motor. Replace motor, also check for obstruction of fan blade.
	Bad inner door seal	Check for moisture on seal. Adjust inner door as necessary (See initial set-up of service manual). Replace door seal.



POSSIBLE PROBLEM	POSSIBLE CAUSE	SERVICE SUGGESTION
Evaporator frosted over	Water at base of evaporator unit	Check for proper drainage (such as plugged drain, kinks in drain tube, etc.), check door seal.
Product freezing up too cold	Temperature setting too low	Adjust temperature setting in electronic controller.
Excessive noise	Fan blade bent or hitting shroud	Straighten, relocate shroud position, or remove shroud.
	Fan motor noisy	Replace if necessary.
	Refrigeration base loose or bent	Tighten bolt or replace if necessary.
Both compressor and condenser fan motors will not operate	Bad refrigeration control relay	Test relay using relay test function of the electronic controller. Replace relay if necessary.
	Bad wiring connection at refrigeration control relay	Check wiring connections. Make corrections if necessary.



## NOTES



# **V-MAX**

## **COCA - COLA LEAN MARKETING VENDOR PARTS SECTION**

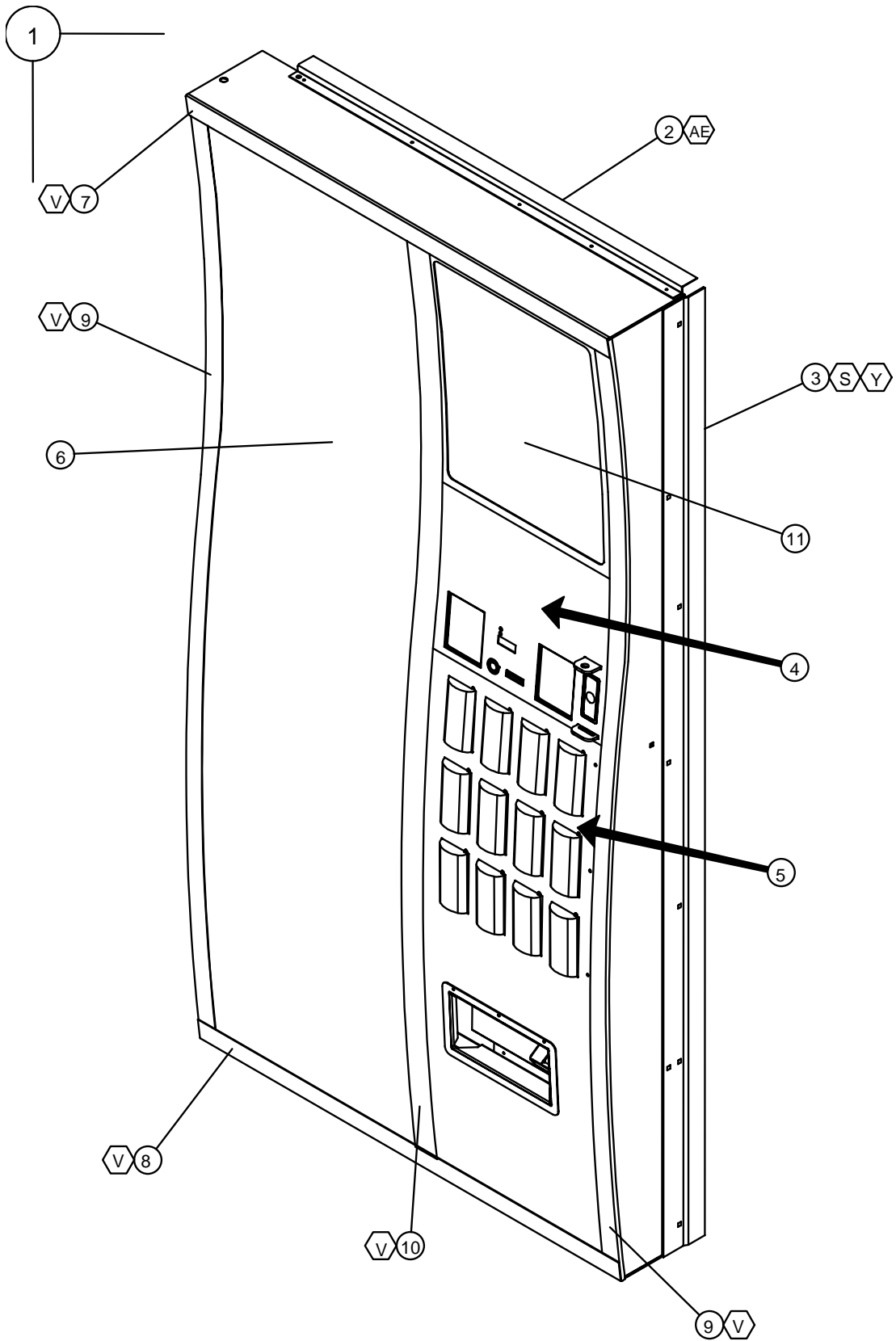



**LEAN MARKETING VENDOR COCA-COLA DOOR**

ITEM NO.	MODEL NUMBER		840	720	576
	DESCRIPTION	QTY REQ	PART NO.	PART NO.	PART NO.
1	DOOR ASSEMBLY	1	*	*	*
2	RAIN GUARD	1	<a href="#">2000848</a>	<a href="#">2000848</a>	2001031
3	DOOR GUARD	1	2010177-2	2010177-3	2010177-3
4	TRANSACTION ASSEMBLY (SEE LMV8-9)	1	~	~	~
5	SELECTION ASSEMBLY (SEE LMV6-7)	1	~	~	~
6	SIGN FACE	1	**	**	**
7	TOP TRIM	1	1124342-1	1124342-1	1124339-1
8	BOTTOM TRIM	1	1124340-1	1124340-1	1124341-1
9	SIDE TRIM	2	1124344-1	1124343-1	1124343-1
10	CENTER TRIM	1	1124346-1	1124345-1	1124345-1
11	AD PANEL	1	**	**	**

\*NOTE: WHEN ORDERING PLEASE PROVIDE **9-CODE** OR **11-CODE**.

\*\*NOTE: WHEN ORDERING SIGN FACE AND AD PANEL, PLEASE PROVIDE **STYLE**.

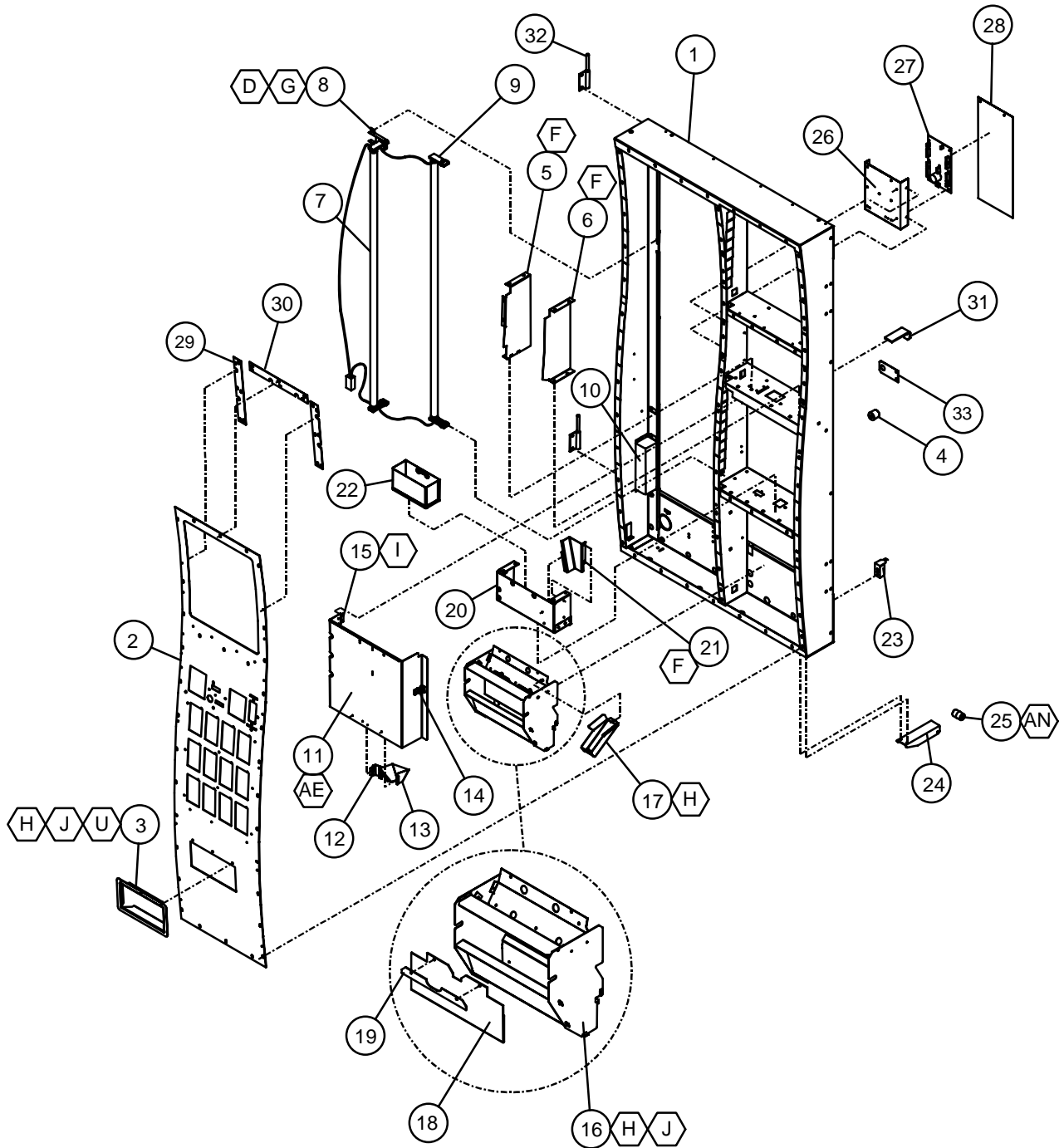



### LEAN MARKETING VENDOR COCA-COLA DOOR

ITEM NO.	DESCRIPTION	MODEL NUMBER		840	720	576
		QTY REQ	PART NO.	PART NO.	PART NO.	
1	DOOR WELD		1124338	1124337	1124336	
2	OVERLAY PANEL (SEE PAGE LMV7)	1	~	~	~	
3	EYELET, HOPPER TRIM	1	1124350	1124350	1124350	
4	DOOR BUMPER	1	1036912	1036912	1036912	
5	DBV VAULT PANEL	1	1124711	1124711	1124711	
6	DBV VAULT PANEL, LOCKSIDE	1	1123907	1123907	1123907	
7	LAMP, T8, 48"	2	<a href="#">1121173-2</a>	<a href="#">1121173-2</a>	<a href="#">1121173-2</a>	
8	LAMP BRACKET	1	1124194	1124233	1124194	
9	LAMP HARNESS	1	1124307	1124307	1124307	
10	BALLAST	1	1122758	1122758	1122758	
11	COINAGE DOOR	1	1124229	1124229	1124229	
12	COINAGE CHUTE	1	1123851	1123851	1123851	
13	COINAGE COIN RETURN CHUTE	1	1124230	1124230	1124230	
14	LATCH, COINAGE DOOR	1	<a href="#">1085546</a>	<a href="#">1085546</a>	<a href="#">1085546</a>	
15	HINGE, COINAGE DOOR	2	<a href="#">388124</a>	<a href="#">388124</a>	<a href="#">388124</a>	
16	HOPPER ASSEMBLY	1	1123886	1123886	1123886	
17	COIN RETURN CUP	1	1123885	1123885	1123885	
18	HOPPER FLAP	1	<a href="#">1123739</a>	<a href="#">1123739</a>	<a href="#">1123739</a>	
19	RETAINER, HOPPER	1	<a href="#">1122875</a>	<a href="#">1122875</a>	<a href="#">1122875</a>	
20	COIN BOX HOUSING ASSEMBLY	1	1124693	1124693	1124693	
21	COIN RETURN CHUTE	1	1123849	1123849	1123849	
22	COIN BOX ASSEMBLY	1	1124391	1124391	1124391	
23	INNER DOOR RAMP	1	<a href="#">1121714</a>	<a href="#">1121714</a>	<a href="#">1121714</a>	
24	ROLLER BRACKET	1	1120552	1120552	1120552	
25	ROLLER	1	<a href="#">1120388</a>	<a href="#">1120388</a>	<a href="#">1120388</a>	
26	VEC MOUNTING BRACKET	1	1120544	1120544	1120544	
27	CONTROL BOARD, VEC 10	1	1120574-107	1120574-107	1120574-107	
28	RAIN CURTAIN, CONTROLLER	1	1120718	1120718	1120718	
29	RETAINER, AD PANEL 32"	*	1124903	1124903	1124903	
30	RETAINER, AD PANEL 39"	1	1124902	~	~	
31	COIN DOOR WEAR PLATE	1	1124228	1124228	1124228	
32	INNER DOOR HINGE, MALE	2	<a href="#">1121287</a>	<a href="#">1121287</a>	<a href="#">1121287</a>	
33	LOCK STUD GUIDE	1	1121356	1121356	1121356	
34	MDB HARNESS (NOT SHOWN)	1	<a href="#">1124570</a>	<a href="#">1124570</a>	<a href="#">1124570</a>	
35	DOOR HARNESS (NOT SHOWN)	1	1120435	1120435	1120435	
36	RAIN CURTAIN, LIGHT (NOT SHOWN)	2	<a href="#">1121838-1</a>	<a href="#">1121838-1</a>	<a href="#">1121838-1</a>	
37	RAIN CURTAIN, BALLAST (NOT SHOWN)	1	1121837	1121837	1121837	

\* NOTE: FOR 840 MACHINE A QTY OF TWO (2) IS REQUIRED. FOR 720 & 576 A QTY OF THREE (3) IS REQUIRED.

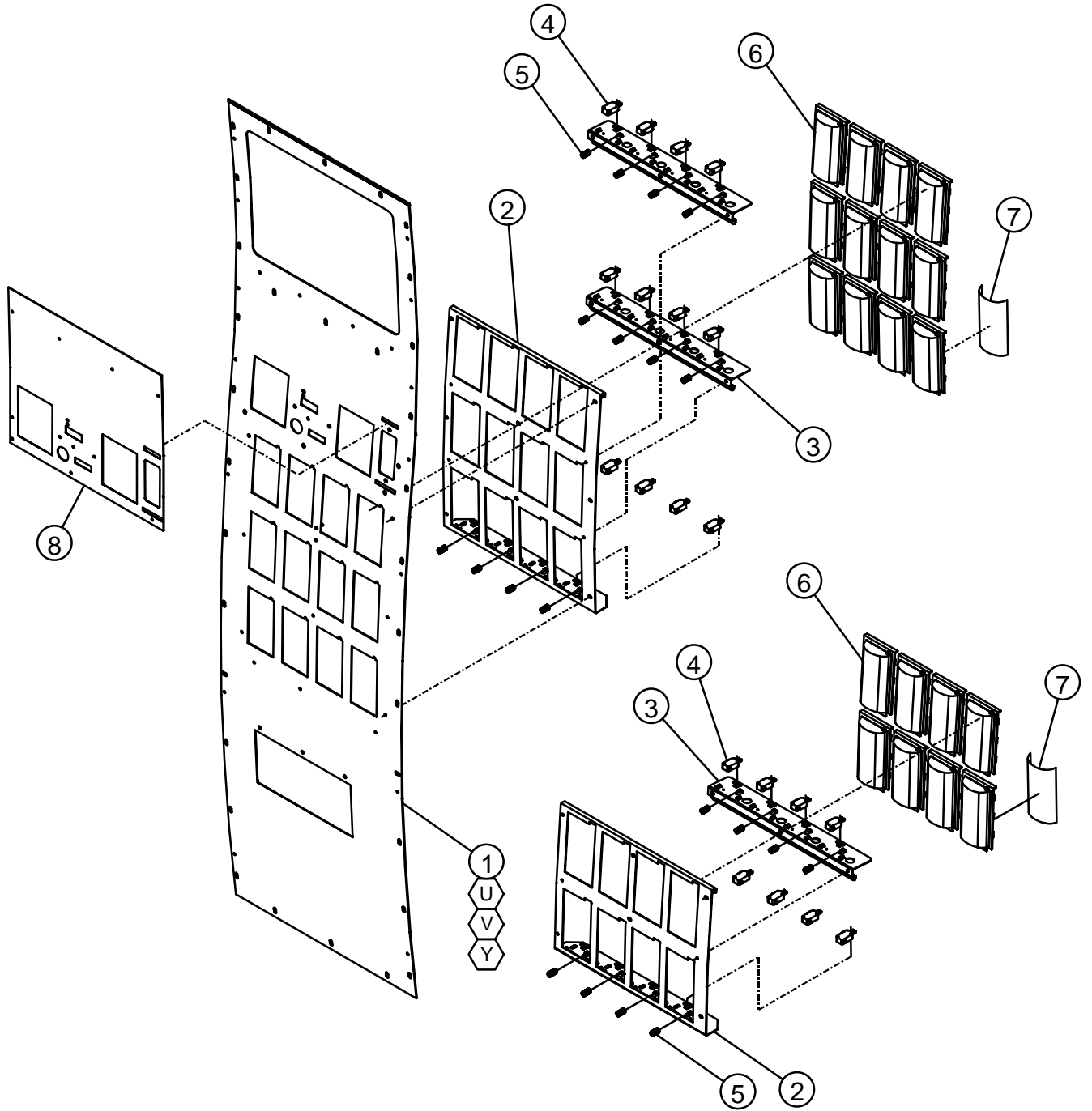



**LEAN MARKETING VENDOR COCA-COLA SELECTION PANEL**

ITEM NO.	DESCRIPTION	QTY REQ	PART NO.
1	CONTROL PANEL OVERLAY, 79"X 39", 12 SELECT	1	1124530
	CONTROL PANEL OVERLAY, 72" X 39", 12 SELECT		1124529
	CONTROL PANEL OVERLAY, 72" X 32", 8 SELECT		1124528
2	BUTTON MOUNT PANEL, 12 SELECT	1	1123829
	BUTTON MOUNT PANEL, 8 SELECT		1123887
3	SWITCH MOUNT BRACKET	1 or 2	1124701
4	SELECTION SWITCH	8 or 12	<a href="#">368299</a>
5	SPRING	8 or 12	<a href="#">388858</a>
6	SELECTION BUTTON	8 or 12	1113171
7	FLAVOR LABEL	8 or 12	*
8	TRANSACTION PANEL OVERLAY, DBV & CARD READER	1	1124348
	TRANSACTION PANEL OVERLAY, NO DBV OR CARD READER	1	1124348-2
9	SELECTION HARNESS, 12 SELECT (NOT SHOWN)	1	1124313
	SELECTION HARNESS, 8 SELECT (NOT SHOWN)	1	1124312

\* WHEN ORDERING FLAVOR LABELS, PLEASE PROVIDE **STYLE**.

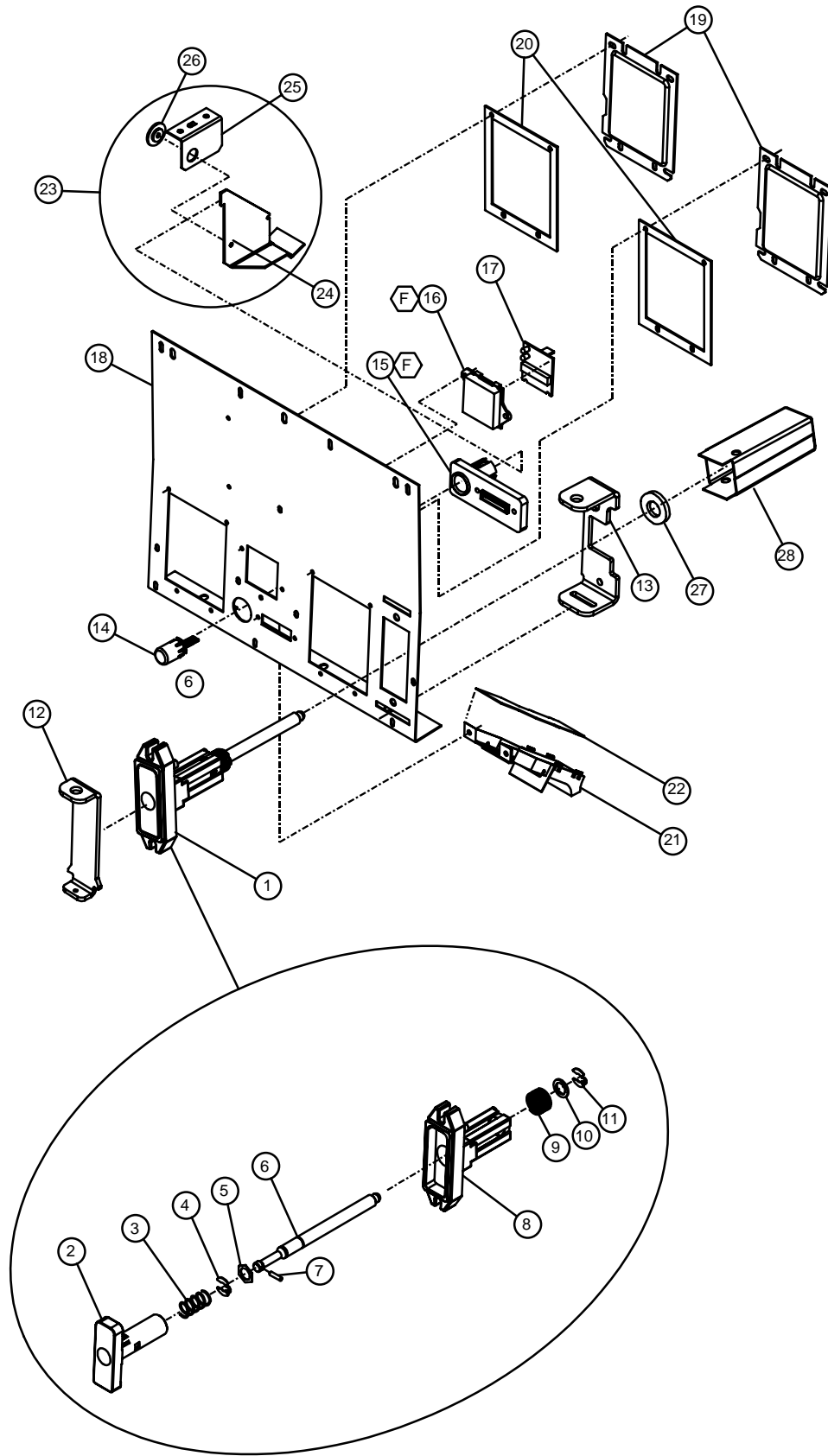

LMV-8



### LEAN MARKETING VENDOR COCA-COLA TRANSACTION ASSEMBLY

ITEM NO.	DESCRIPTION	QTY REQ	PART NO.
1	T-HANDLE LOCK ASSEMBLY	1	1124191
2	T-HANDLE	1	1116732
3	SPRING	1	389691
4	E-RING RETAINER	1	<a href="#">388589</a>
5	HEX WASHER	1	387600
6	LOCK STUD	1	1122399
7	PIN - STUD	1	387601
8	FLANGE	1	1116724
9	SPRING - HEAVY	1	<a href="#">389690</a>
10	FLAT WASHER	1	<a href="#">V801023</a>
11	E-RING RETAINER	1	<a href="#">388589</a>
12	LOCK COVER (OPTIONAL)	1	1120340
13	HASP - LOCK COVER (OPTIONAL)	1	1120339
14	COIN RETURN BUTTON	1	<a href="#">1050473</a>
15	COIN INSERT GUIDE PLATE	1	<a href="#">1123820</a>
16	DISPLAY COVER	1	1039652
17	DISPLAY	1	1089678
18	TRANSACTION PANEL	1	1124681
19	DBV PLATE	2	1124614
20	DBV GASKET	2	<a href="#">1086759</a>
21	COIN INSERT CHUTE	1	1123900
22	COIN INSERT CAP	1	1123898
23	COIN RETURN LEVER ASSEMBLY	1	1124371
24	COIN RETURN CRANK	1	1123823
25	COIN RETURN LEVER MOUNT	1	1123822
26	SHOULDER WASHER, NYLON	1	<a href="#">1122715</a>
27	VAPOR SEAL	1	<a href="#">388132</a>
28	LOCK STUD COVER	1	1122126
29	DISPLAY HARNESS (NOT SHOWN)	1	1120438

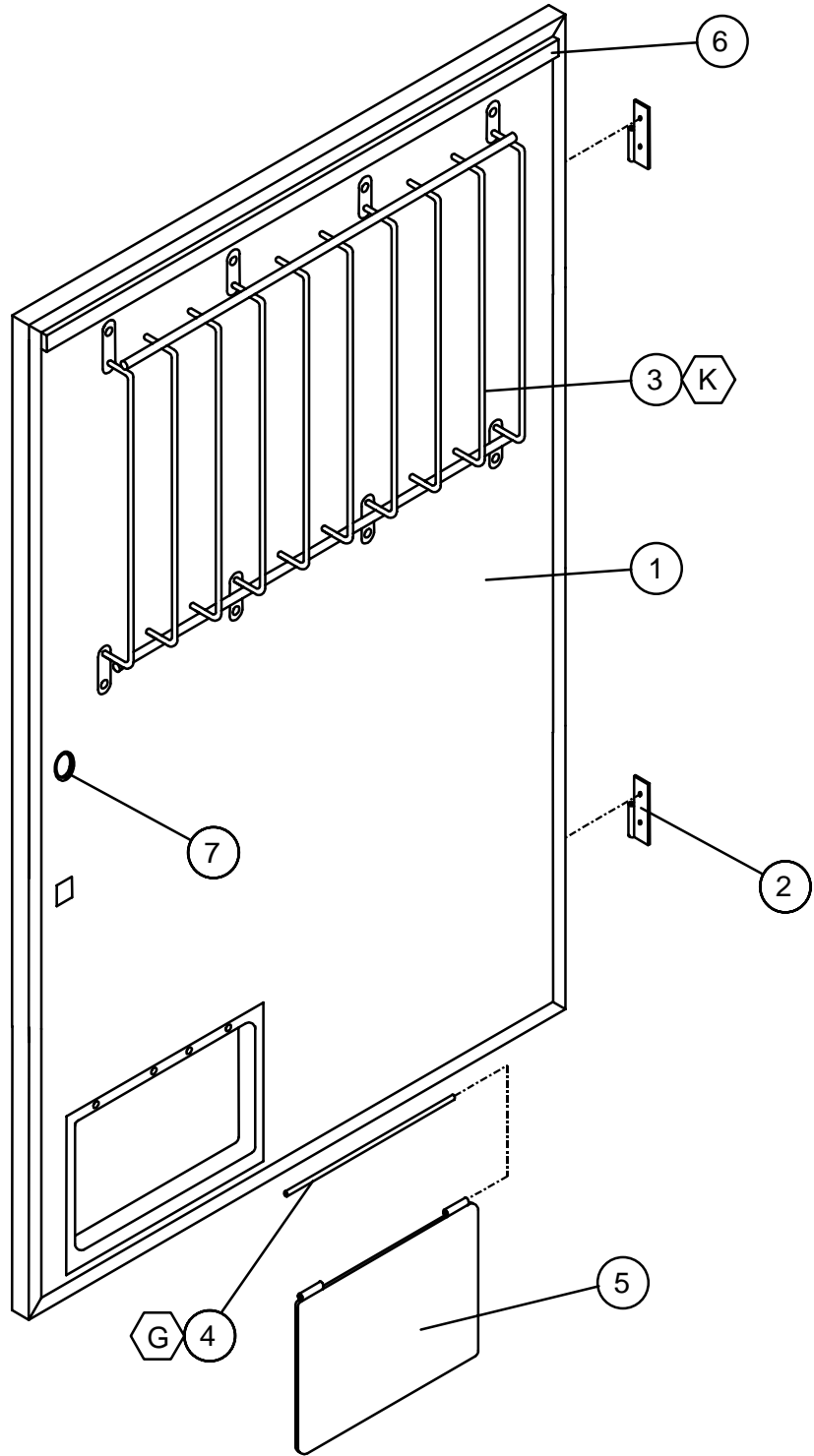



**LEAN MARKETING VENDOR COCA-COLA INNER DOOR ASSEMBLY**

ITEM NO.	MODEL NUMBER		840	720	576
	DESCRIPTION	QTY REQ	PART NO.	PART NO.	PART NO.
1	INNER DOOR ASSEMBLY (FOAMED)	1	134302-52	134302-51	134302-110
2	HINGE - FEMALE	1	<a href="#">1121286</a>	<a href="#">1121286</a>	<a href="#">1121286</a>
3	PROD. RETAINER UPPER	2	1120633-3	1120633-2	1124408
4	PIN - HINGE	1	389985	389985	389985
5	FLAP - DOOR (REVERSIBLE)	1	<a href="#">1013076</a>	<a href="#">1013076</a>	10130736
6	RAIN SEAL - INNER DOOR	1	<a href="#">1111732-2</a>	<a href="#">1111732-2</a>	<a href="#">1111732-2</a>
7	GROMMET	2	<a href="#">388090</a>	<a href="#">388090</a>	<a href="#">388090</a>
~	SEAL - INNER DOOR ( <b>NOT SHOWN</b> )	1	<a href="#">1075678-1</a>	<a href="#">1075678</a>	<a href="#">1075678-2</a>

**INNER DOOR LABELS – NOT SHOWN**

DESCRIPTION	MODEL NUMBER		840	720	576
	QTY REQ		PART NO.	PART NO.	PART NO.
LABEL - PRODUCT SET-UP GUIDE ( <b>NOT SHOWN</b> )	1		1122196	1122196	1122196
LABEL - ERROR CODES VEC 10 ( <b>NOT SHOWN</b> )	1		1120609	1120609	1120609
LABEL - PROGRAMMING VEC 10 ( <b>NOT SHOWN</b> )	1		1121018	1121018	1121018
LABEL - WIRING DIAGRAM ( <b>NOT SHOWN</b> )	1		1120611	1120611	1120611
LABEL – CONFIGURATION ( <b>NOT SHOWN</b> )	1		1111457	1111457	1111457
LABEL – SPACE TO SALES VEC 10 ( <b>NOT SHOWN</b> )	1		1122244	1122244	1122244

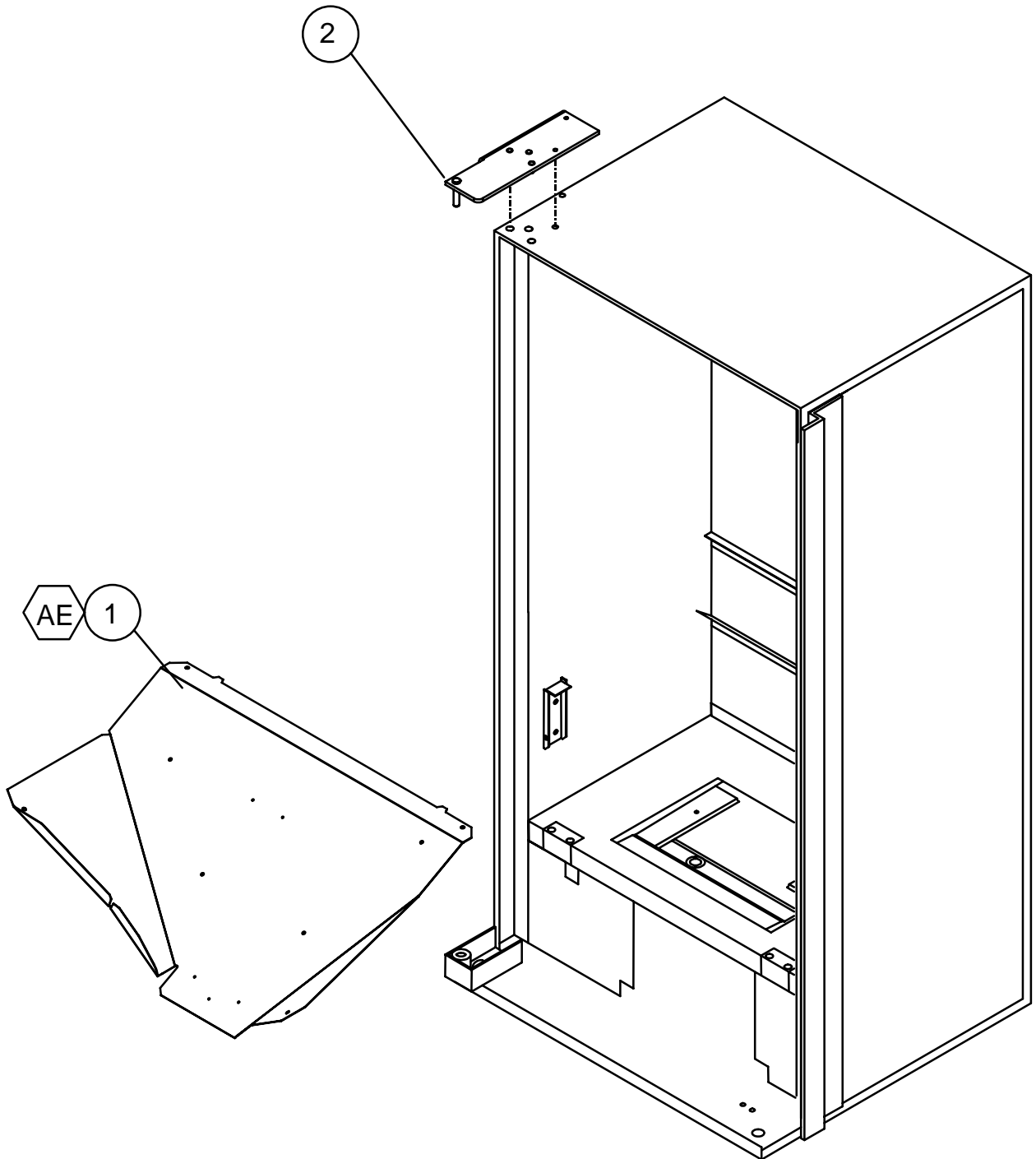





**LEAN MARKETING VENDOR COCA-COLA CABINET ASSEMBLY**

ITEM NO.	DESCRIPTION	QTY REQ	PART NO.
1	PRODUCT CHUTE ASSEMBLY, 39"	1	2008643-03
~	PRODUCT CHUTE ASSEMBLY, 32"	1	2008643-06
2	TOP HINGE ASSEMBLY	1	<a href="#">2000805-03</a>



## NOTES