

OPERATOR'S MANUAL



Model 104 Batch Freezer

Original Operating Instructions

053064-M

8/13/08 (Original Publication)
(Updated 8/5/2020)

Section 1: To the Installer

Installer Safety	1-1
Site Preparation	1-1
Air-Cooled Units	1-2
Electrical Connections.	1-2
60-Cycle Units.	1-3
Beater Rotation	1-3
Refrigerant	1-3

Section 2: To the Operator

Compressor Warranty Disclaimer	2-2
--	-----

Section 3: Safety

Section 4: Parts

Model 104	4-1
Beater Door Assembly	4-2
Accessories.	4-3

Section 5: User Interface

Control Switch.	5-1
Orange Dial Light	5-1
Safety	5-1
Timer Control	5-1
Door Hinge	5-2
Reset Condition.	5-2

Section 6: Operating Procedures

Assembly.	6-1
Sanitizing.	6-4
Priming	6-6
Overrun.	6-6
Drawing Product	6-7
Rinsing	6-8
Cleaning	6-8
Disassembly	6-8
Brush-Cleaning	6-9

Section 7: Operator Checklist

During Cleaning and Sanitizing.	7-1
Troubleshooting Bacterial Count.	7-1
Regular Maintenance Checks.	7-1
Winter Storage	7-1

Table of Contents

Section 8: Troubleshooting

Section 9: Parts Replacement Schedule

Section 10: Limited Warranty on Equipment

Section 11: Limited Warranty on Parts

The following information has been included in the manual as safety and regulatory guidelines. For complete installation instructions, please see the Installation Checklist.

Installer Safety



IMPORTANT! In all areas of the world, equipment should be installed in accordance with existing local codes. Please contact your local authorities if you have any questions.

Care should be taken to ensure that all basic safety practices are followed during the installation and servicing activities related to the installation and service of Taylor® machines.

- Only Taylor service personnel should perform installation, maintenance, and repairs on Taylor machines.
- Authorized service personnel should consult OSHA Standard 29CFR1910.147 or the applicable code of the local area for the industry standards on lockout/tagout procedures before beginning any installation or repairs.
- Authorized service personnel must ensure that the proper protective equipment (PPE) is available and worn when required during installation and service.
- Authorized service personnel must remove all metal jewelry, rings, and watches before working on electrical equipment.



DANGER! The main power supply(s) to the machine must be disconnected prior to performing any installation, maintenance, or repairs. Failure to follow this instruction may result in personal injury or death from electrical shock or hazardous moving parts as well as poor performance or damage to the machine.

Note: All repairs must be performed by a Taylor service technician.



WARNING! This machine has many sharp edges that can cause severe injuries.

Site Preparation

Review the area where the machine will be installed before you uncrate the machine. Make sure that all possible hazards the user or equipment may come into contact with have been addressed.



WARNING! Only install this machine in a location where its use and maintenance is restricted to trained personnel. Failure to comply may result in personal injury.

For Indoor Use Only: This machine is designed to operate indoors, under normal ambient temperatures of 70°F to 75°F (21°C to 24°C). The freezer has successfully performed in high ambient temperatures of 104°F (40°C) at reduced capacities.



WARNING! This machine must **NOT** be installed in an area where a water jet or hose can be used. **NEVER** use a water jet or hose to rinse or clean the machine. Failure to follow this instruction may result in electrocution.



CAUTION! This machine must be installed on a level surface to avoid the hazard of tipping. Extreme care should be taken in moving this machine for any reason. Two or more persons are required to safely move this machine. Failure to comply may result in personal injury or damage to the machine.

The authorized installer should inspect the machine for damage and promptly report any damage to the local authorized Taylor distributor.

This machine is made using USA sizes of hardware. All metric conversions are approximate and vary in size.

Air-Cooled Machines

Do not obstruct air intake and discharge openings.

Air-cooled machines require a minimum of 6 in. (152 mm) of clearance around all sides of the freezer to allow for adequate air flow across the condenser(s). Failure to allow adequate clearance can reduce the refrigeration capacity of the freezer and possibly cause permanent damage to the compressor.

1

Electrical Connections

In the United States, this equipment is intended to be installed in accordance with the National Electrical Code (NEC), ANSI/NFPA 70-1987. The purpose of the NEC code is the practical safeguarding of persons and property from hazards arising from the use of electricity. This code contains provisions considered necessary for safety. In all other areas of the world, equipment should be installed in accordance with the existing local codes. Contact your local authorities.



Each machine requires one power supply for each data label on the machine. Check the data label on the freezer for branch circuit over current protection or fuse, circuit ampacity and other electrical specifications. Refer to the wiring diagram provided inside of the electrical box for proper power connections.



WARNING! This machine must be properly grounded. Failure to do so can result in severe personal injury from electrical shock.



IMPORTANT! An equipotential grounding lug is provided with this machine. Some countries require the grounding lug to be properly attached to the rear of the frame by the authorized installer. The installation location is marked by the equipotential bonding symbol (5021 of IEC 60417-1) on both the removable panel and the machine's frame.



IMPORTANT!

- *Stationary machines which are not equipped with a power cord and a plug or another device to disconnect the machine from the power source must have an all-pole disconnecting device with a contact gap of at least 0.125 in. (3 mm) installed in the external installation.*
- *Machines that are permanently connected to fixed wiring and for which leakage currents may exceed 10 mA, particularly when disconnected or not used for long periods, or during initial installation, shall have protective devices, to protect against the leakage of current such as a GFI, installed by the authorized personnel to the local codes.*
- *Supply cords used with this machine shall be oil-resistant, sheathed flexible cable not lighter than ordinary polychloroprene or other equivalent synthetic elastomer-sheathed cord (code designation 60245 IEC 57) installed with the proper cord anchorage to relieve conductors from strain, including twisting, at the terminals and protect the insulation of the conductors from abrasion.*
- *If the supply cord is damaged, it must be replaced by a Taylor service technician in order to avoid a hazard.*
- *Secure the supply cord ground lead to the machine in a location where if the cord is pulled, the main power leads will become taut before the ground lead can break loose.*

60-Cycle Machines

This equipment is supplied with a three-wire cord and grounding type of plug, for connection to a single-phase, 60-cycle, branch circuit supply. This machine must be plugged into a properly grounded receptacle. Permanent wiring may be employed if required by local codes. Instructions for conversion to permanent wiring are as follows.

1. Make sure the freezer is electrically disconnected.
2. Remove the rear panel and locate the small electrical box at the base of the freezer.
3. Remove the factory-installed cord and strain-relief bushing.

4. Route incoming permanent wiring through the 7/8 in. (22 mm) hole in the base pan.
5. Connect two power supply leads. Attach the ground (earth) wire to the grounding lug inside the electrical box.
6. Make sure the machine is properly grounded before applying power.



CAUTION! Use only approved refrigerant listed on the machine's data label or authorized through a manufacturer's technical bulletin. The use of any other refrigerant may expose users and operators to unexpected safety hazards.

Beater Rotation



NOTICE! Beater rotation must be clockwise as viewed looking into the freezing cylinder.

To correct the rotation on a three-phase unit, interchange any two incoming power supply lines at the freezer main terminal block only. To correct rotation on a single-phase unit, exchange leads inside the beater motor. (Follow the diagram printed on the motor.)

Electrical connections are made directly to the terminal block provided in the main control box located behind the service panel.

It is recommended that beater rotation service be performed by a Taylor service technician.



WARNING! Refrigerant liquid sprayed onto the skin may cause serious damage to tissue. Keep eyes and skin protected. If refrigerant burns should occur, flush the area immediately with cold water. If burns are severe, apply ice packs and contact a physician



NOTICE! Taylor reminds technicians to be aware of and in compliance with local government laws regarding refrigerant recovery, recycling, and reclaiming systems. For information regarding applicable local laws, please contact your local authorized Taylor distributor.

Refrigerant



CAUTION! This machine contains fluorinated greenhouse gases (F-Gas) to provide refrigeration using a hermetically sealed circuit or within foam insulation. This machine's type of gas, quantity, Global Warming Potential (GWP), and CO₂ tonnes equivalent information is recorded on the machine's data label. The refrigerant used is generally considered nontoxic and nonflammable. However any gas under pressure is potentially hazardous and must be handled with caution.

NEVER fill any refrigerant cylinder completely with liquid. Filling the cylinder approximately 80% will allow for normal expansion.



IMPORTANT! *Refrigerants and their associated lubricants may be extremely moisture absorbent. When opening a refrigeration system, the maximum time the system is open must not exceed 15 minutes. Cap all open tubing to prevent humid air or water from being absorbed by the oil.*

The freezer you have purchased has been carefully engineered and manufactured to provide dependable operation. The Taylor Model 104 Batch Ice Cream freezer, when properly operated and cared for, produces a consistent quality product. Like all mechanical products, this machine requires cleaning and maintenance. A minimum amount of care and attention is necessary if the operating procedures outlined in this manual are followed closely.



NOTICE! DO NOT operate this machine without reading this entire manual first. Failure to follow all of these operating instructions may result in damage to the machine, poor performance, health hazards, or personal injury.

Model 104 does **not** compensate and correct for any errors during the setup or filling operations. Therefore, the initial assembly and priming procedures are of extreme importance. It is strongly recommended that personnel responsible for the machine's operation, both assembly and disassembly, go through these procedures together to be properly trained and to make sure that no misunderstandings exist.

If you require technical assistance, please contact your local authorized Taylor distributor.

Note: Your Taylor warranty is valid only if the parts used are authorized Taylor parts purchased from the local authorized Taylor distributor, and only if all required service work is provided by a Taylor service technician. Taylor reserves the right to deny warranty claims on units or parts if Taylor-unapproved parts or incorrect refrigerant were installed in the unit, if system modifications were performed beyond factory recommendations, or if it is determined that the failure was caused by abuse, misuse, neglect, or failure to follow all operating instructions. For full details of your Taylor warranty, see the Limited Warranty section in this manual.



IMPORTANT! If the crossed-out wheeled-bin symbol is affixed to this machine, it signifies that this machine is compliant with the EU Directives as well as other similar end-of-life legislation in effect after August 13, 2005. Therefore, it must be collected separately after its use is completed and cannot be disposed as unsorted municipal waste.

The user is responsible for returning the machine to the appropriate collection facility, as specified by your local code.

For additional information regarding applicable local disposal laws, please contact the municipal waste facility and/or local authorized Taylor distributor.

Compressor Warranty Disclaimer

The refrigeration compressor(s) on this unit are warranted for the term stated in the Limited Warranty section in this manual. However, due to the Montreal Protocol and the U.S. Clean Air Act Amendments of 1990, many new refrigerants are being tested and developed, thus seeking their way into the service industry. Some of these new refrigerants are being advertised as drop-in replacements for numerous applications. It should be noted that in the event of ordinary service to this unit's refrigeration system, **only the refrigerant specified on the affixed data label should be used.** The unauthorized use of alternate refrigerants will void your Taylor compressor warranty. It is the unit owner's responsibility to make this fact known to any technician he/she employs.

It should also be noted that Taylor does not warrant the refrigerant used in its equipment. For example, if the refrigerant is lost during the course of ordinary service to this unit, Taylor has no obligation to either supply or provide replacement refrigerant either at billable or unbillable terms. Taylor does have the obligation to recommend a suitable replacement if the original refrigerant is banned, obsoleted, or no longer available during the five year warranty of the compressor.

Taylor will continue to monitor the industry and test new alternates as they are being developed. Should a new alternate prove, through our testing, that it would be accepted as a drop-in replacement, then the above disclaimer would become null and void. To find out the current status of an alternate refrigerant as it relates to your compressor warranty, call the local Taylor distributor or the Taylor Factory. Be prepared to provide the model/serial number of the unit in question.

We at Taylor Company are concerned about the safety of the operator at all times when they are coming in contact with the machine and its parts. Taylor makes every effort to design and manufacture built-in safety features to protect both operators and service technicians.

Installing and servicing refrigeration equipment can be hazardous due to system pressure and electrical components. Only trained and qualified service personnel should install, repair, or service refrigeration equipment. When working on refrigeration equipment, observe precautions noted in the literature, tags, and labels attached to the machine, and other safety precautions that may apply. Follow all safety code requirements. Wear safety glasses and work gloves.



DANGER! Failure to adhere to the following safety precautions may result in severe personal injury or death. Failure to comply with these warnings may also damage the machine and/or its components. Such damage may result in component replacement and service repair expenses.



NOTICE! DO NOT operate this machine without reading this entire manual first. Failure to follow all of these operating instructions may result in damage to the machine, poor performance, health hazards, or personal injury.



IMPORTANT! *This machine is to be used only by trained personnel. It is not intended for use, cleaning, or maintenance by children or people with reduced physical, sensory, or mental capabilities or lack of experience and knowledge. Where limited machine operation is allowed for public use, such as a self-serve application, supervision or instruction concerning the use of the machine by a person responsible for their safety is required. Children should be supervised to ensure that they do not play with the machine.*



WARNING! This machine must **NOT** be installed in an area where a water jet or hose can be used. **NEVER** use a water jet or hose to rinse or clean the machine. Failure to follow this instruction may result in electrocution.



WARNING! Avoid injury.

- **DO NOT** operate the machine unless it is properly grounded.
- **DO NOT** operate the machine with fuses larger than specified on the machine's data label.
- All repairs should be performed by a Taylor service technician.
- The main power supplies to the machine must be disconnected prior to performing installation, repairs, or maintenance.
- **For Cord-Connected Machines:** Only Taylor service technicians or licensed electricians may install a plug or replacement cord on the machine.
- Machines that are permanently connected to fixed wiring and for which leakage currents may exceed 10 mA, particularly when disconnected or not used for long periods, or during initial installation, shall have protective devices to protect against the leakage of current, such as a GFI, installed by the authorized personnel to the local codes.
- Stationary machines which are not equipped with a power cord and a plug or another device to disconnect the machine from the power source must have an all-pole disconnecting device with a contact gap of at least 0.125 in. (3 mm) installed in the external installation.
- Supply cords used with this machine shall be oil-resistant, sheathed flexible cable not lighter than ordinary polychloroprene or other equivalent synthetic elastomer-sheathed cord (code designation 60245 IEC 57) installed with

the proper cord anchorage to relieve conductors from strain, including twisting, at the terminals and protect the insulation of the conductors from abrasion.

- If the supply cord is damaged, it must be replaced by an Taylor service technician in order to avoid a hazard.
- Secure the supply cord ground lead to the machine in a location where if the cord is pulled, the main power leads will become taut before the ground lead can break loose.

Failure to follow these instructions may result in electrocution. Contact your local authorized Taylor distributor for service.

3



IMPORTANT! An equipotential grounding lug is provided with this machine. Some countries require the grounding lug to be properly attached to the rear of the frame by the authorized installer. The installation location is marked by the equipotential bonding symbol (5021 of IEC 60417-1) on both the removable panel and the machine's frame.



WARNING! Avoid injury.

- **DO NOT** allow untrained personnel to operate this machine.
- **DO NOT** operate the machine unless all service panels and access doors are restrained with screws.
- **DO NOT** remove any internal operating parts (including, but not limited to, freezer door, beater, or scraper blades), unless all control switches are in the off position.

Failure to follow these instructions may result in severe personal injury, especially to fingers or hands, from hazardous moving parts.



WARNING! This machine has many sharp edges that can cause severe injuries.

- **DO NOT** put objects or fingers in the door spout. This may contaminate the product and cause severe personal injury from blade contact.
- **USE EXTREME CAUTION** when removing the beater assembly. The scraper blades are very sharp.



WARNING! Only install this machine in a location where its use and maintenance is restricted to trained personnel. Failure to comply may result in personal injury.



CAUTION! This machine must be placed on a level surface. Extreme care should be taken when moving for any reason. Two or more persons are required to safely move this machine. Failure to comply may result in personal injury or damage to the machine.



NOTICE! Cleaning and sanitizing schedules are governed by your federal, state, or local regulatory agencies and must be followed accordingly. Please refer to the cleaning section of this manual for the proper procedure to clean this machine.



CAUTION! This machine is equipped with a refrigerated cabinet, designed to maintain product temperature at or below 41°F (5°C). Before replenishing the mix supply, the product must be refrigerated at or below 41°F (5°C). Failure to follow this instruction may result in health hazards and poor freezer performance.

DO NOT run the machine without product. Failure to follow this instruction can result in damage to the machine.

DO NOT obstruct air intake and discharge openings. A minimum of 3 in. (76 mm) air clearance on both sides of the machine is required. It is recommended to place the rear of the machine against the wall to prevent the

recirculation of warm air. Failure to follow this instruction may cause poor freezer performance and damage to the machine.

For Indoor Use Only: This machine is designed to operate indoors, under normal ambient temperatures of 70°F to 75°F (21°C to 24°C). The machine has successfully performed in high ambient temperatures of up to 104°F (40°C) at reduced capacities.

Noise Level: Airborne noise emission does not exceed 78 dB(A) when measured at a distance of 39 in. (1.0 m) from the surface of the machine and at a height of 62 in. (1.6 m) from the floor.

Model 104

4

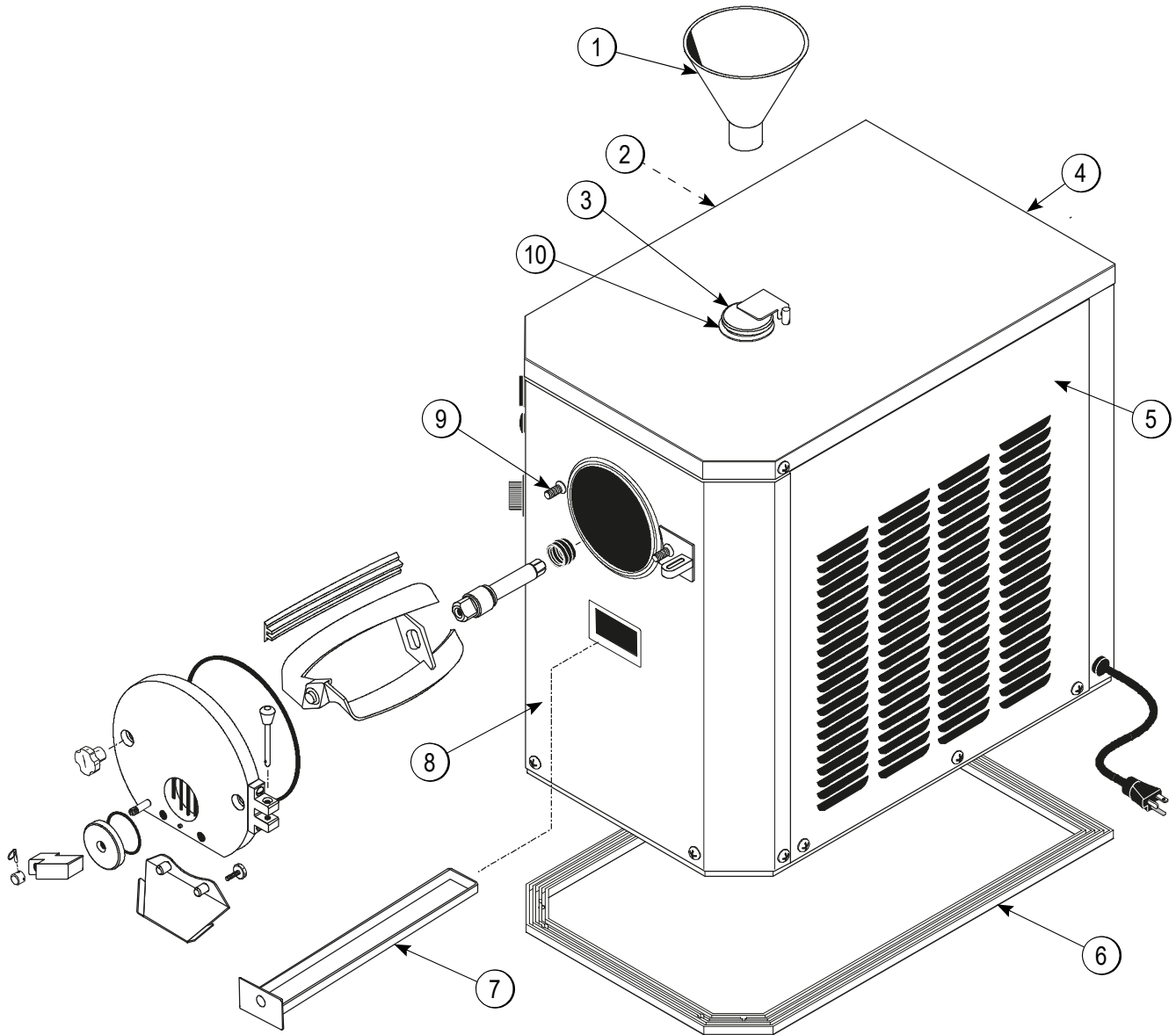

Figure 4-1

Item	Description	Part No.
1	Funnel	034252
2	Panel- Side Left	051039
3	Cover A.-Mix Inlet	X24948
4	Panel- Rear	051040
5	Panel- Side Right	051038

Item	Description	Part No.
6	Gasket- Base Pan	049420
7	Pan- Drip 13- 1/4 Long	039027
8	Panel A.- Front	X51043
9	Stud- Freezer	023057
10	Bezel	033406

Beater Door Assembly

4

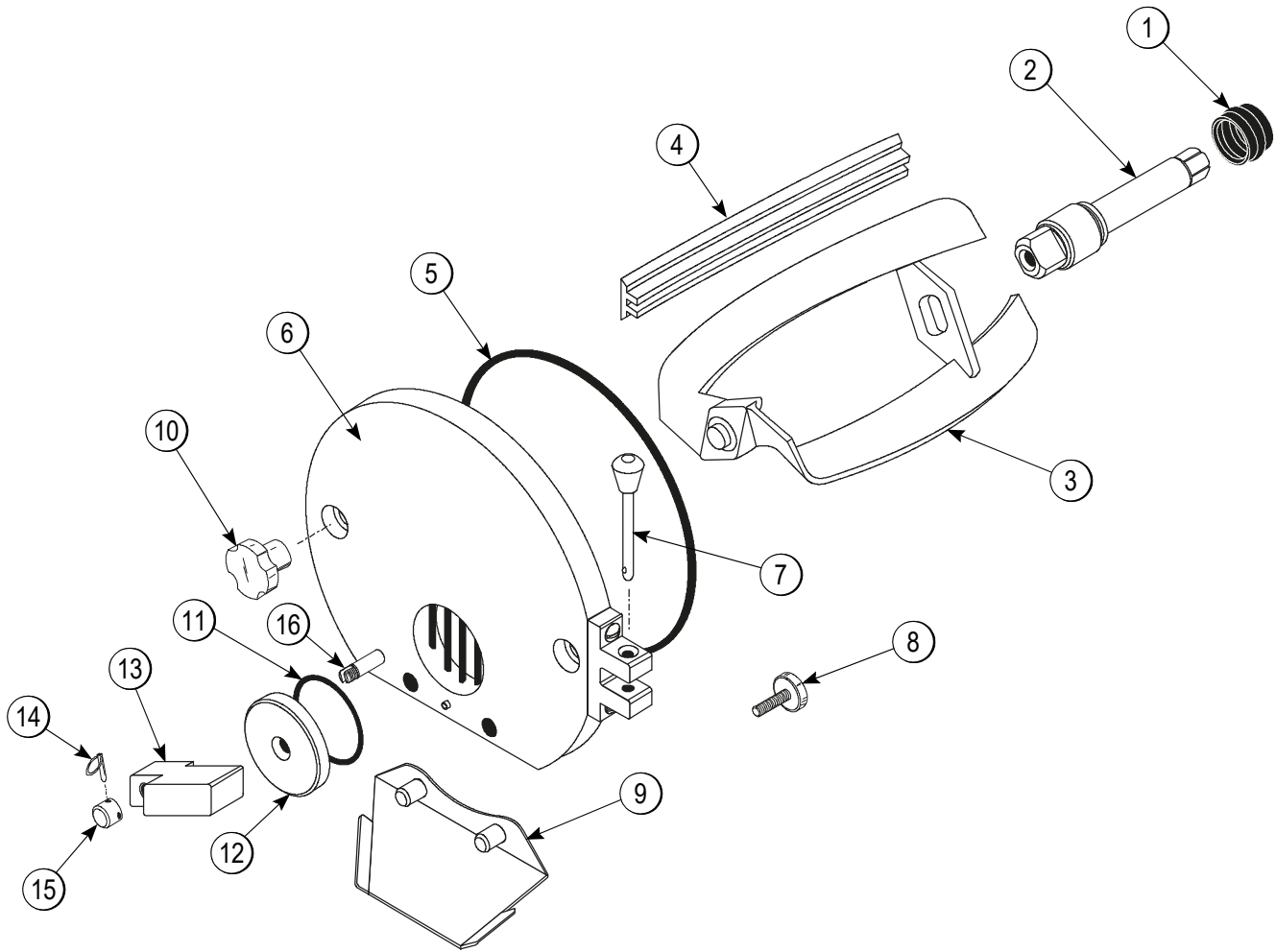
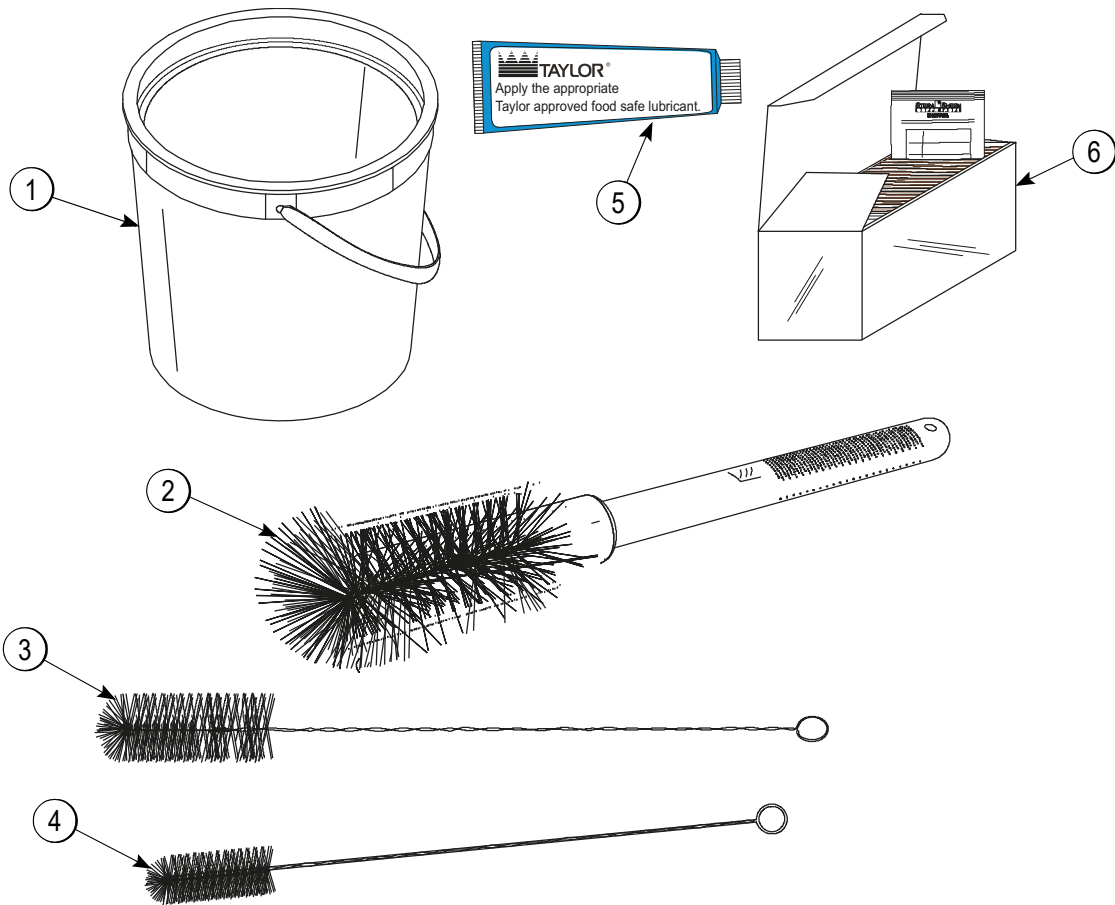

Figure 4-2

Item	Description	Part No.
1	Seal- Drive Shaft	032560
2	Shaft- Beater	033498
3	Beater Assembly	X33417
4	Blade- Scraper 7- 1/4" L	033277
5	O-ring 5- 7/16 OD x 5- 1/4	033276
6	Door A.- Partial	X37710
7	Pin A.- Pivot 1- 3/4 Grip	X37705
8	Screw- Stem	034662

Item	Description	Part No.
9	Spout A.- Drip	X33422
10	Nut- Stud	008614
11	O-ring 2- 1/4 OD x .139 W	030890
12	Plate- Draw	027811
13	Arm- Handle	030042
14	Pin- Quick Release 3/16	027813
15	Cap- Stem	027812
16	Stem- Freezer Cover	034661

Accessories



4

Figure 4-3

Item	Description	Part No.
1	Pail-6 qt.	023348
2	Brush-Mix Pump Body 3" x 7"	023316
3	Brush-Rear Bearing 1" x 2"	013071

Item	Description	Part No.
4	Brush-Draw Valve 1-1/2"	014753
5	Lubricant-Taylor 4 oz.	047518
6	Sanitizer-Stera Sheen®	See Note

***Note:** A sample container of sanitizer is sent with the unit. For reorders, order Stera-Sheen® Part No. 055492 (100 two-oz. packs).

User Interface

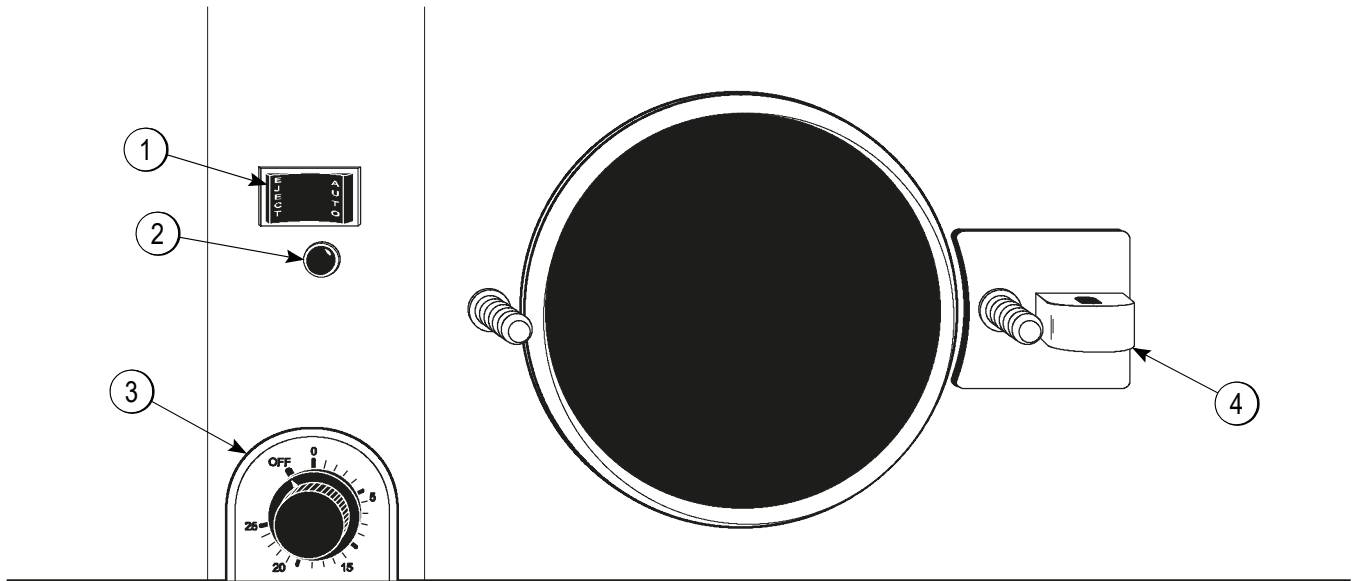

Figure 5-1

Item	Description
1	Control Switch
2	Orange Dial Light
3	Timer Control
4	Door Hinge

Control Switch

When the control switch (1) is placed in the Auto mode and the timer is adjusted to the desired setting, the refrigeration system operates. When the switch is placed in the Eject mode, only the beater motor operates.

Orange Dial Light

Located below the control switch is an orange dial light (2). When the control switch is in the AUTO position, this light turns on, indicating the refrigeration system is operable when the timer is set.

Safety

Never empty the contents of the freezing cylinder while the control switch is in the AUTO position. Always put the control switch into the EJECT position when drawing product from the freezing cylinder. As an additional safety feature, this machine does **not** operate if the door is open.

Timer Control

Model 104 uses a timer control (3) to operate the compressor and determine the viscosity of the product. After the desired amount of product has been added to the freezing cylinder, turn the timer for the amount of refrigeration required for the batch. The timer setting varies due to mix variations and desired finished product viscosity.

Once the desired time is set, put the control switch into the AUTO position. The compressor and beater motor operate until the time is up. When the timer setting elapses, the refrigerating process is canceled. The dial light and beater assembly continues to operate. A tone sounds, signaling the operator to dispense the finished product. Turn the control switch to the EJECT position. The product is ready to draw off and serve.

Start with 5 minutes and increase as needed. Times and temperatures are dependent on specific mix formulations, pre-charge amounts, and finished product preferences.

Note: *Because the freezing cylinder for the first batch is at room temperature, the first batch freeze-down time will be longer than subsequent batches.*

Door Hinge

The door hinge (4) allows you to open the door without removal. This feature is primarily used when changing flavors and cleaning up is necessary.

Reset Condition

Model 104 is equipped with an internal motor overload protection. Should an overload occur, the reset mechanism trips, canceling freezer operation. To properly reset the freezer, put the control switch into the OFF position. Allow the beater motor to cool. Then return the control switch to its original position.

Note: *If the unit went out on reset, the product may have been run too cold or too long. Therefore, after resetting the freezer, check the temperature control or the time set.*

Model 104 is a small 3 qt. (2.9 L) capacity ice cream freezer. This model produces a rich-tasting, nominal-overrun ice cream product that can be drawn off and placed in a hardening cabinet or flash freezer. Overrun can be varied depending on mix formulation, amount of pre-charge, and finished product temperature. We begin our instructions at the point when we find the parts disassembled and laid out to air-dry from the previous brush-cleaning.

The following procedures show you how to assemble the parts into the freezer, sanitize them, and prime the freezer with fresh mix to prepare the first batch.

If you are disassembling the machine for the first time or need information to get to this starting point in our instructions, see "Disassembly" on page 6-8.

Assembly



WARNING! Make sure the power switch is in the off position. Failure to follow this instruction may result in severe personal injury from hazardous moving parts.

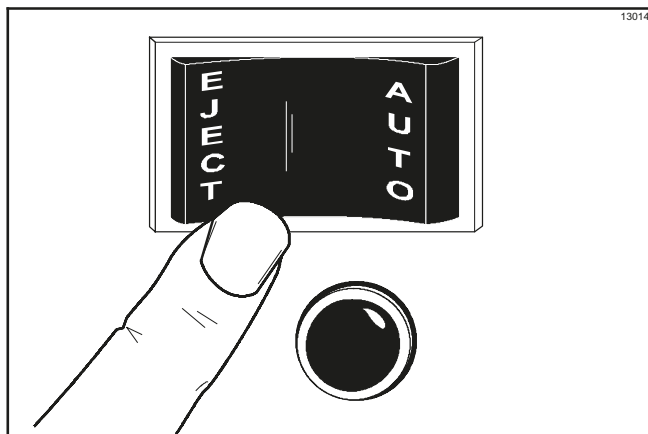

Figure 6-1

1. Install the driveshaft. Using Taylor Lube, lubricate the groove and shaft portion that comes in contact with the bearing on the beater driveshaft. Slide the seal over the shaft and groove until it snaps into place. **Do not** lubricate the hex end of the driveshaft. Partially fill the inside portion of the seal with additional lubricant. Lubricate the flat side of the seal that comes in contact with the bearing.

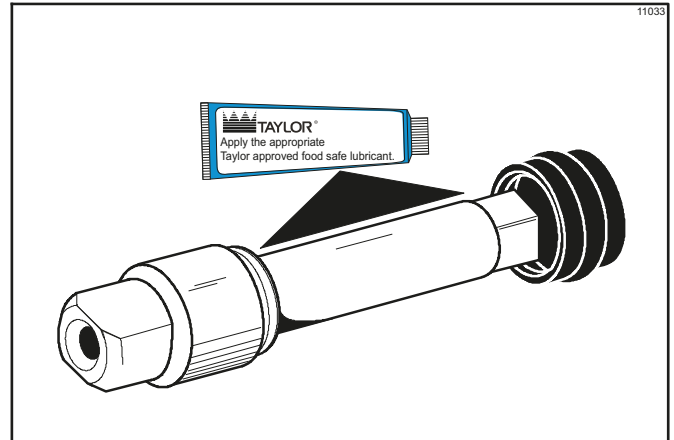

Figure 6-2

2. Insert the driveshaft through the rear shell bearing and engage the hex end firmly into the gear box coupling. Make sure that the driveshaft fits into the coupling without binding.

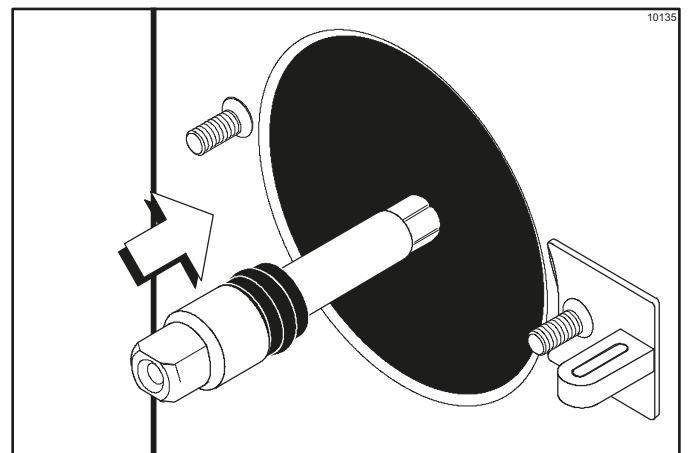

Figure 6-3

3. Place the plastic scraper blades on the beater. Make sure one end of the blade is up against the notch at the front of the beater.

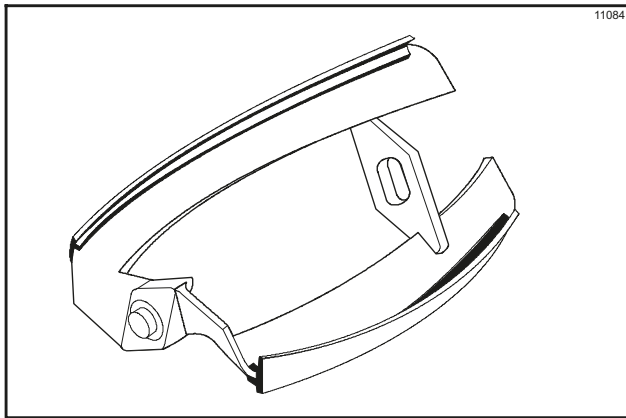

Figure 6-4

4. Holding the beater and blades securely, slide the beater into the freezing cylinder about one-third of the way in. Looking into the freezing cylinder, align the hole at the rear of the beater with the flats on the end of the driveshaft.

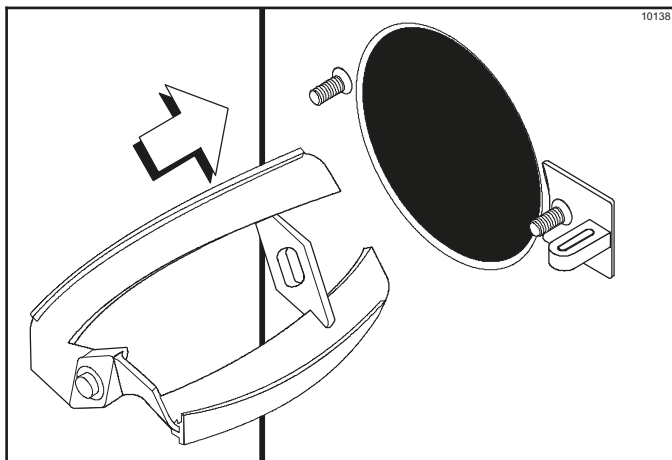

Figure 6-5

5. Slide the beater the remainder of the way into the freezing cylinder and over the driveshaft. The beater should fit snugly but not so tightly that the beater cannot be turned to engage the driveshaft. When in position, the beater does not protrude beyond the front of the freezing cylinder.
6. Assemble the freezer door. Place the large freezer door O-ring in the groove on the back of the freezer door.

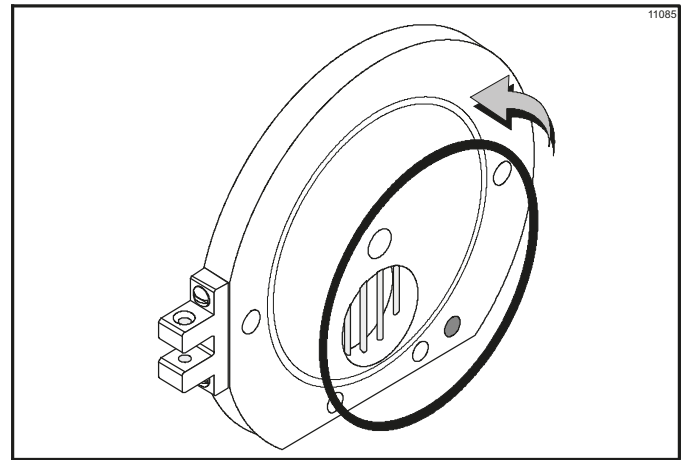

Figure 6-6

7. Press the O-ring into the groove on the back of the freezer door and lubricate **lightly**.

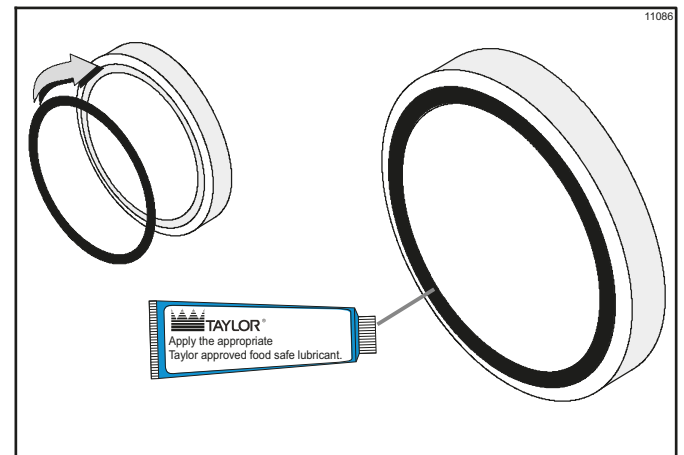

Figure 6-7

8. Lay the draw plate and O-ring facedown over the ejection port.

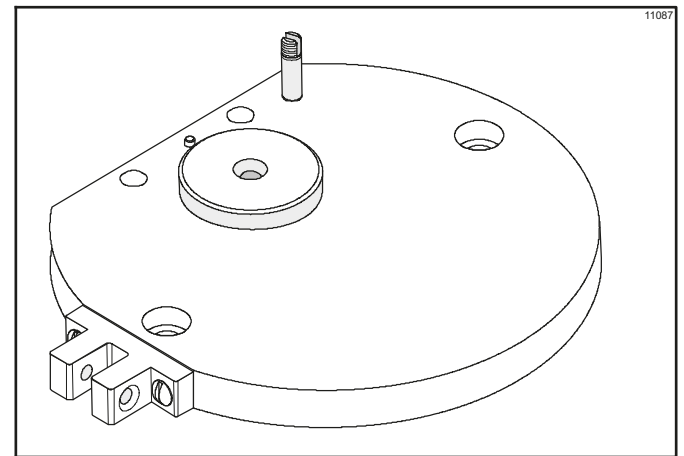

Figure 6-8

9. Align the hole in the draw arm over the stem on the freezer door and push down. Make sure the draw arm fits into the depression in the draw plate.

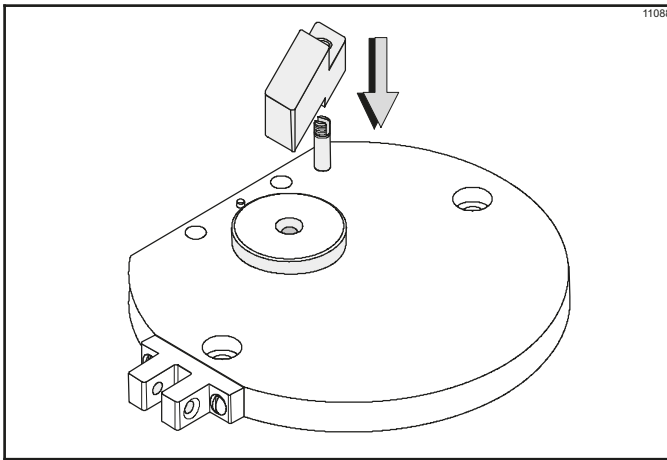

Figure 6-9

10. Screw the stem cap over the stem that protrudes from the draw arm. Once snug, tighten it to align the holes in the cap with the slot in the stem.

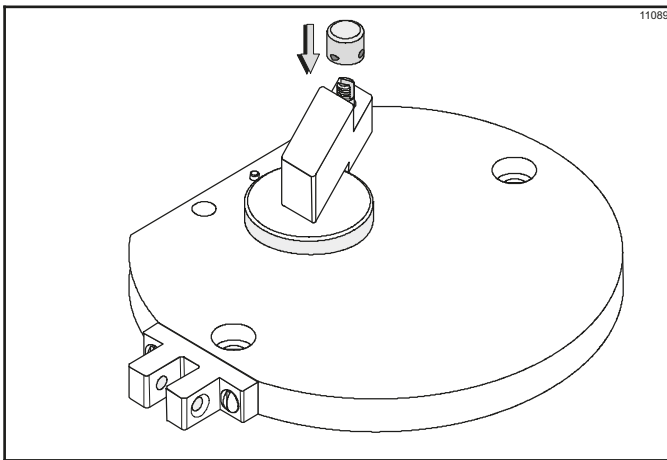

Figure 6-10

11. Secure the cap with the clevis pin.

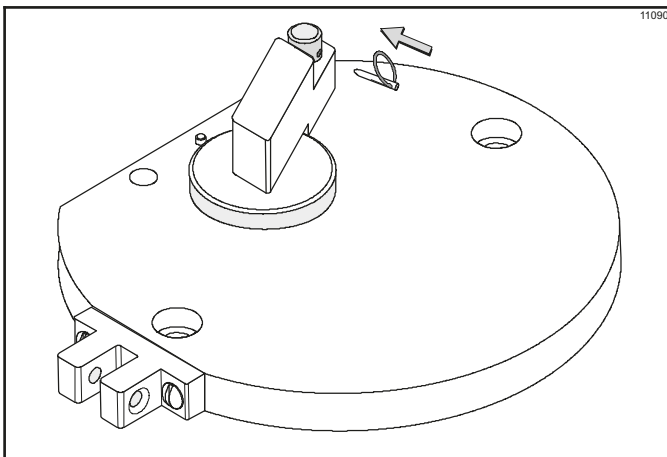

Figure 6-11

12. Engage the drip-spout pins with the holes on the back side of the freezer door.

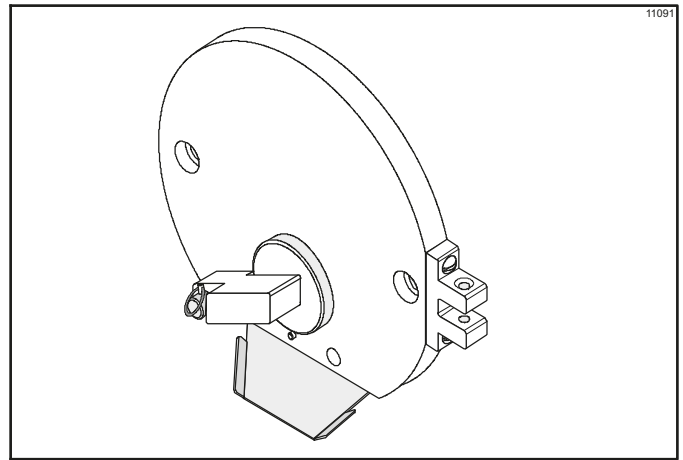

Figure 6-12

13. Position the door onto the two studs on the front of the freezing cylinder. Make sure the hole in the back of the door is aligned with the bearing on the end of the beater.

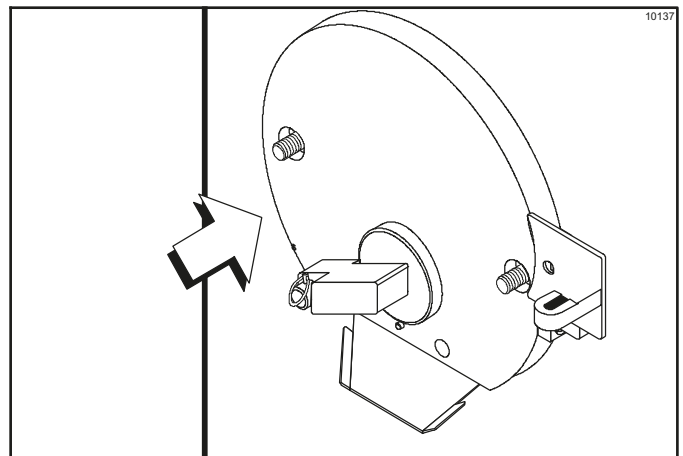

Figure 6-13

14. Install the two handscrews onto the studs and tighten them equally.

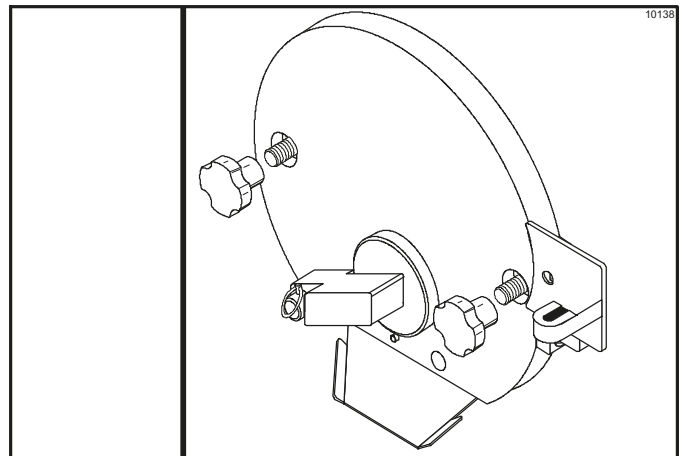

Figure 6-14

OPERATING PROCEDURES

15. Secure the freezer door hinge by installing the pivot pin.

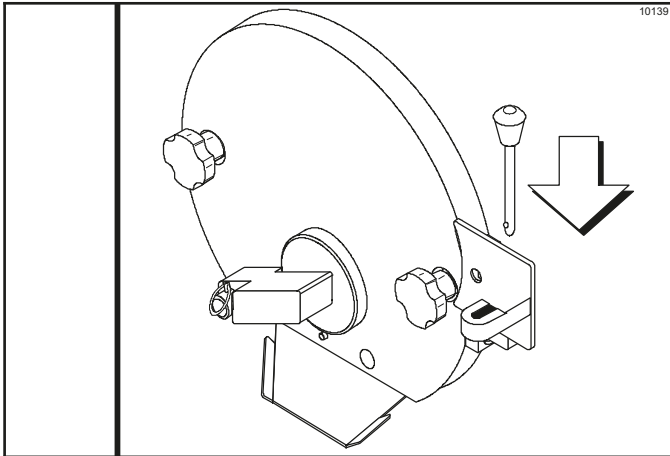

Figure 6-15

16. Slide the drip pan into the hole in the front panel.

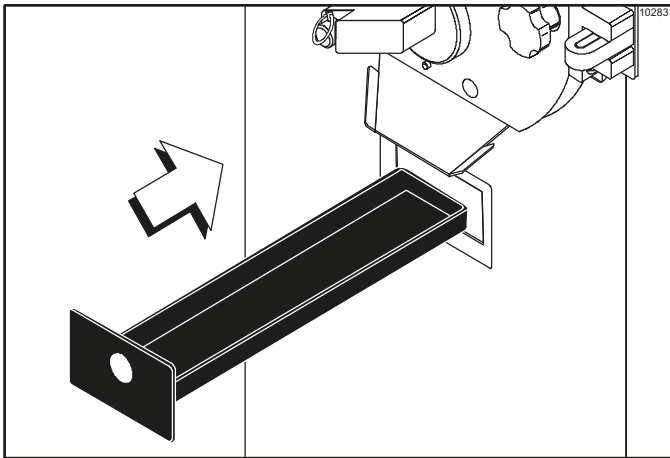

Figure 6-16

Sanitizing

1. Prepare 2 qt. (1.9 L) of an approved 100 ppm sanitizing solution (for example, Stera-Sheen®). Use warm water and follow the manufacturer's specifications.
2. Open the mix inlet cover on top of the freezer.

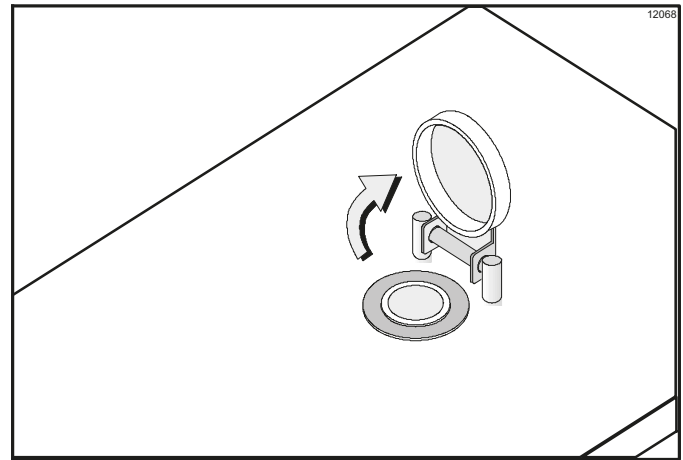

Figure 6-17

Note: Sanitize your hands and the funnel.

3. Install the funnel into the mix inlet hole on top of the freezer.

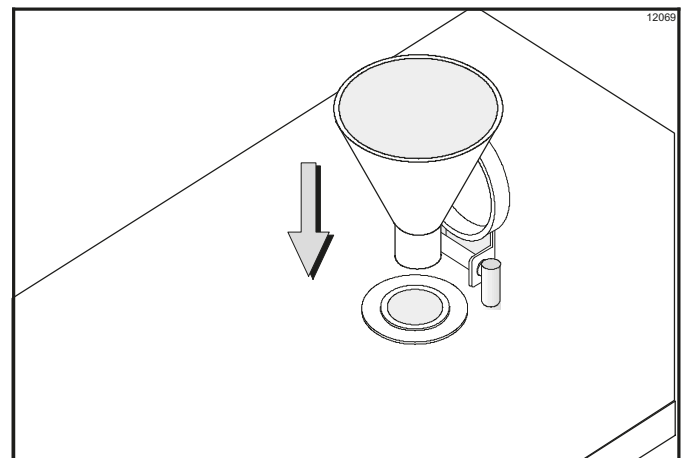

Figure 6-18

4. Pour the sanitizing solution into the funnel and allow the solution to flow into the freezing cylinder.

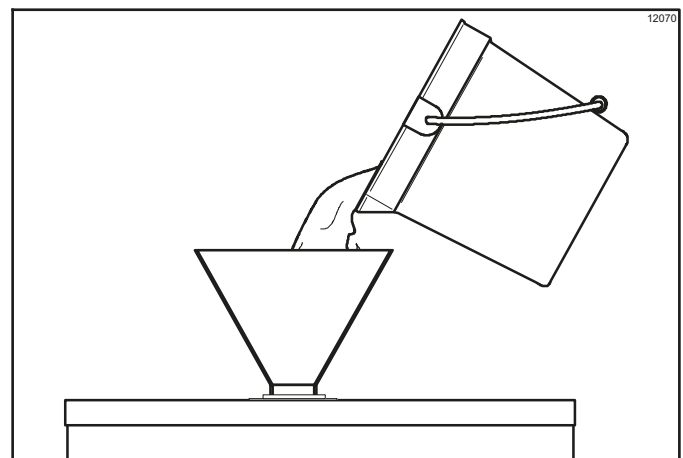

Figure 6-19

- Put the control switch into the EJECT position.
This causes the sanitizing solution in the freezing cylinder to be agitated. Allow it to agitate for five minutes.



WARNING! Keep fingers out of fill and discharge openings. Failure to do so may result in personal injury or component damage.

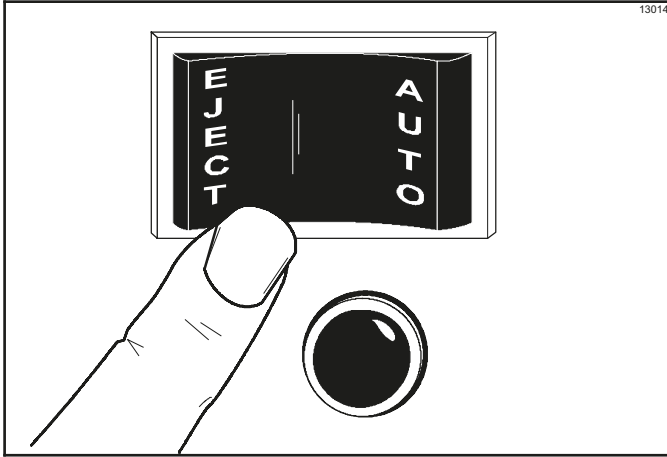

Figure 6-20

- Put the control switch into the off position.
- Hold a pail beneath the ejection port, open the draw arm, and drain the sanitizing solution from the freezing cylinder.
- Close the draw arm.

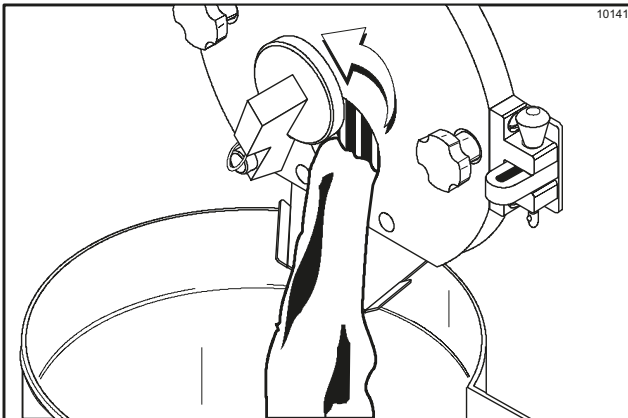

Figure 6-21

Priming

- With the control switch in the off position, hold an empty pail beneath the ejection port and open the draw arm.



WARNING! Keep fingers out of fill and discharge openings. Failure to do so may result in personal injury or component damage.

- Pour the desired amount of mix into the funnel. The mix in the freezing cylinder will force out any remaining sanitizing solution.
- When full-strength mix is flowing from the ejection port, close the draw arm.

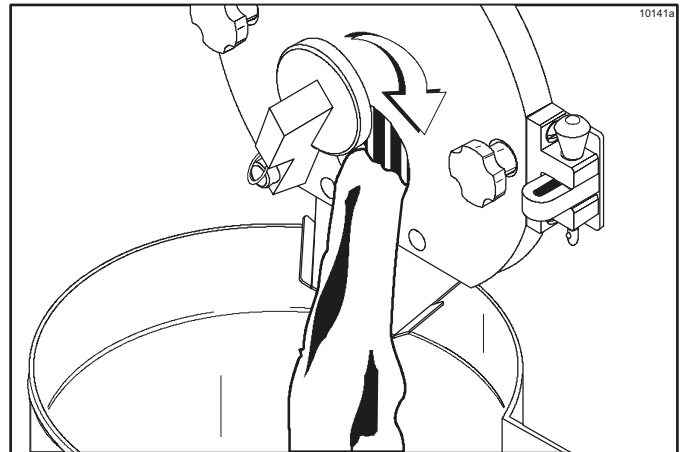

Figure 6-22

- Set the timer for the time required for the batch. Allow the unit to operate until the buzzer sounds and the refrigeration system automatically cycles off.

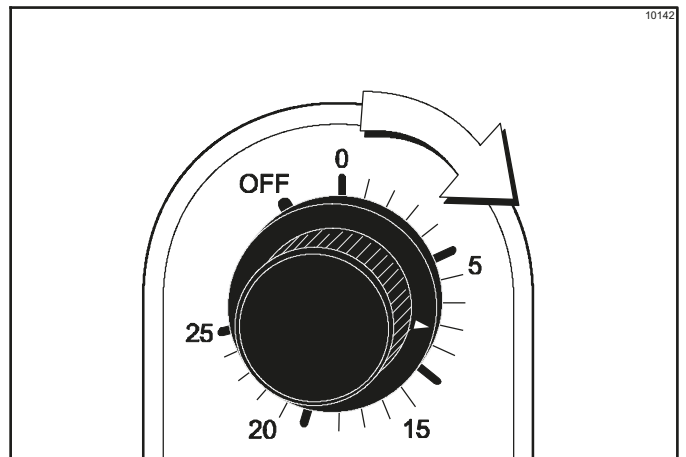

Figure 6-23

- Place the control switch in the AUTO position.

OPERATING PROCEDURES

6. Remove the funnel and close the mix inlet cover.

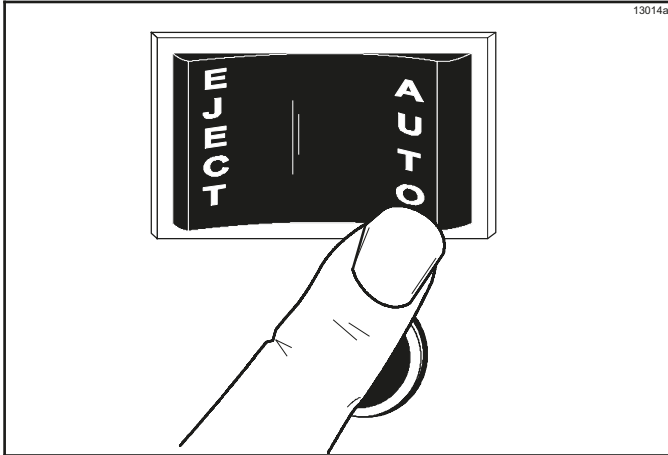

Figure 6-24

Overrun

Depending on the overrun desired, the amount of pre-charge can range from 1.5 qt. to 3 qt. (1.4 L to 2.8 L). This gives an overrun between 20% and 100%. Overrun which exceeds 100% must not be taken below 26°F (-3.3°C) or the product will not eject. Depending on the mix, product overrun below 100% may be taken as low as 18°F (-7.7°C) with no ejection problem. If ejection problems do exist, then the product has been taken too cold.

- 6 Place the control switch in the EJECT position and take a sample of the product to determine overrun. If the overrun is **not** at the desired level, leave the control switch in the EJECT position to agitate the product and blend more air into the mixture. Continue to take samples until the desired overrun is obtained.

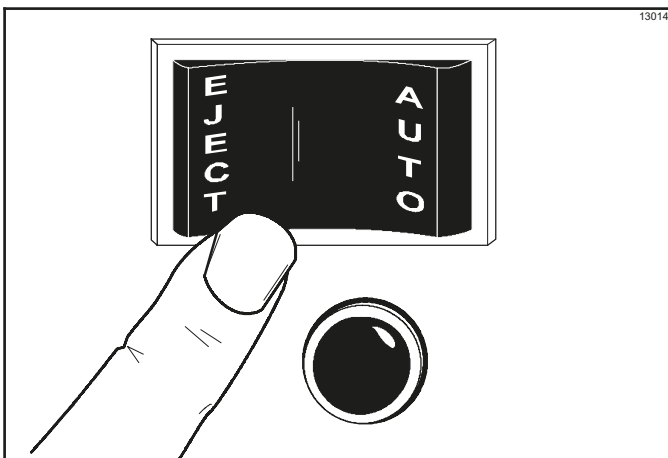

Figure 6-25

1. Use a standard overrun scale and a one-pint measuring cup.

2. Place an empty cup on the scale and adjust the scale pointer to the zero setting.

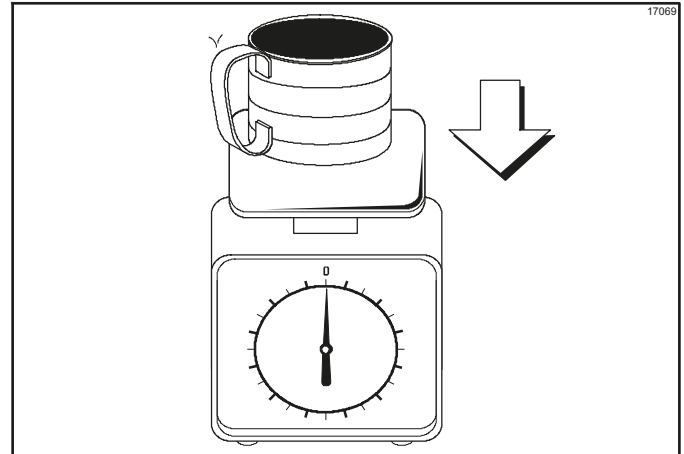

Figure 6-26

3. Draw off one pint of frozen product. With a straightedge, level off the top.

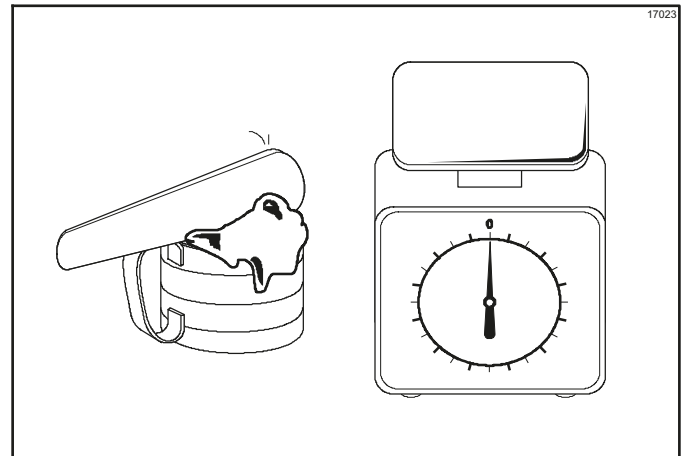

Figure 6-27

4. Place the pint of product on the scale. Read the overrun directly off the scale.

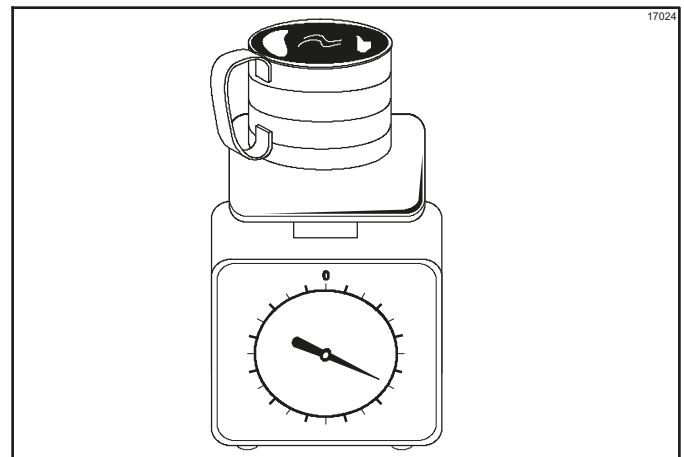

Figure 6-28

OPERATING PROCEDURES

- Put the control switch into the off position.
- Hold a pail beneath the ejection port, open the draw arm, and drain all the solution from the freezing cylinder.
- Close the draw arm.

Disassembly



WARNING! Make sure the power switch is in the off position. Failure to follow this instruction may result in severe personal injury from hazardous moving parts.

- Remove the handscrews from the front of the freezer door.
- Remove the pivot pin from the hinge on the freezer door. Remove the freezer door, beater assembly, scraper blades, and driveshaft from the freezing cylinder.
- Remove the funnel from the top of the freezer and the rear drip pan from the front panel.

Note: If the drip pan is filled with an excessive amount of mix, the seal was installed incorrectly on the beater assembly or should be replaced.

6

Brush-Cleaning

- Prepare a sink with an approved cleaning solution (for example, Stera-Sheen®).

Use warm water and follow the manufacturer's specifications.

If an approved cleaner other than Stera-Sheen® or Kay-5® is used, dilute the cleaner according to label instructions.

Important! Follow label directions. Too **strong** of a solution can cause parts damage, while too **mild** of a solution will not provide adequate cleaning. Make sure all brushes provided with the freezer are available for brush-cleaning.

- Remove the seal from the driveshaft.

- From the freezer door:
 - Remove the clevis pin from the stem cap.
 - Unscrew the stem cap from the stem.
 - Pull the draw arm from the stem.
 - Remove the O-ring from the draw plate.
 - Remove the O-ring from the back of the freezer door.
 - Remove the drip spout and take the parts to the sink for cleaning.
- Thoroughly brush-clean all disassembled parts in the cleaning solution.
- Make sure all lubricant and mix film is removed. Place the cleaned parts on a clean dry surface to air-dry.
- Return to the freezer with a small amount of cleaning solution. With the black bristle brush, brush-clean the rear shell bearing at the back of the freezing cylinder.

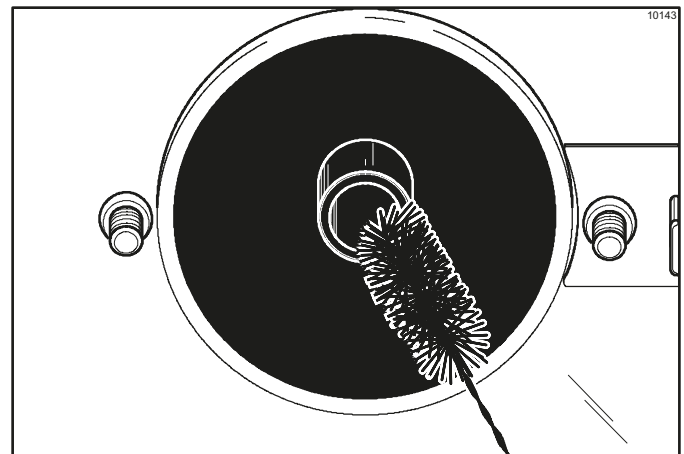

Figure 6-29

- Wipe clean all exterior surfaces of the freezer.

During Cleaning and Sanitizing



ALWAYS FOLLOW LOCAL HEALTH CODES.

Cleaning and sanitizing schedules are governed by your state or local regulatory agencies and must be followed.

Use the following check points during the cleaning and sanitizing operations.

Important! *Cleaning the machine is recommended after the necessary batches have been prepared for the day. Sanitize the machine at the beginning of each day.*

Troubleshooting Bacterial Count

- Thoroughly clean and sanitize the machine regularly, including complete disassembly and brush-cleaning.
- Use all brushes supplied for thorough cleaning. The brushes are specially designed to reach all mix passageways.
- Use the white bristle brush to clean the mix inlet hole, which extends from the mix hopper down to the rear of the freezing cylinder.
- Use a screwdriver and cloth towel to clean the female hex drive socket and rear shell bearing free of lubricant and mix deposits.
- Use the black bristle brush to thoroughly clean the rear shell bearing located at the rear of the freezing cylinder. Use a generous amount of cleaning solution on the brush.
- Properly prepare the cleaning and sanitizing solutions. Read and follow label directions carefully. Too **strong** of a solution may damage the parts, and too **weak** of a solution will **not** adequately clean or sanitize.
- The temperature of mix in the mix hopper and walk-in cooler should be below 40°F (4.4°C).
- Follow your local health codes when using flavorings, fruits, or nuts in this machine.

Regular Maintenance Checks

- Check the rear shell bearing for signs of wear (excessive mix leakage in rear drip pan) and make sure it is properly cleaned.
- Dispose of seals if they are worn, torn, or fit too loosely, and replace them with new ones.
- Follow all lubricating procedures described in "Assembly" on page 6-1.
- Replace scraper blades that are damaged or nicked. Before installing the beater assembly, make sure that scraper blades are properly attached to the beater assembly.
- If your machine is air-cooled, check the condensers for dirt and lint. Dirty condensers reduces the efficiency and capacity of the machine. Condensers should be cleaned **monthly** with a soft brush. **Never** use screwdrivers or other metal probes to clean between the fins.

Winter Storage

If the place of business is to be closed during the winter months, it is important to protect the freezer by following certain precautions, particularly if the building is to be left unheated and subject to freezing conditions.

Disconnect the freezer from the main power source to prevent possible electrical damage.

Wrap detachable parts of the freezer (such as the beater, blades, driveshaft, and freezer door) and place them in a protected, dry place. Rubber trim parts and gaskets can be protected by wrapping them with moisture-proof paper. All parts should be thoroughly cleaned of dried mix or lubrication accumulations, which can attract mice and other vermin.

Problem	Probable Cause	Remedy	Page Ref.
1. Poor ejection.	<ul style="list-style-type: none"> a. Over refrigeration. b. Inadequate pre-charge c. The beater is rotating counterclockwise. 	<ul style="list-style-type: none"> a. Use less time to run the batch. b. Increase the pre-charge. c. Contact service technician to correct beater rotation to clockwise. 	<ul style="list-style-type: none"> --- --- ---
2. No beater operation with the control switch in the AUTO position.	<ul style="list-style-type: none"> a. The machine is unplugged. b. The circuit breaker is off, or the fuse is blown. c. The machine is out on reset. d. The freezer door is open. 	<ul style="list-style-type: none"> a. Plug into wall receptacle. b. Turn the breaker on or replace the fuse. c. Put the freezer in the OFF position. Allow the machine to cool. Resume normal operation, but use less time to run the batch. d. Secure the door for freezer operation. 	<ul style="list-style-type: none"> --- --- 5-1 6-2
3. The product is not freezing.	<ul style="list-style-type: none"> a. The timer control is not set or is defective. b. The condensers are dirty on air-cooled machines. c. The control switch is not in the AUTO position. 	<ul style="list-style-type: none"> a. Set time for required batch or contact service technician to replace the timer. b. Clean condensers monthly. c. Put the control switch into the AUTO position for compressor operation. 	<ul style="list-style-type: none"> 5-1 7-1 5-1
4. There is excessive mix leakage in the rear drip tray.	<ul style="list-style-type: none"> a. The seal on the beater driveshaft is missing or worn. b. The rear shell bearing is worn. c. There is improper lubrication on the beater drive shaft. 	<ul style="list-style-type: none"> a. Install or replace the seal on the beater driveshaft. b. Contact service technician to replace the bearing. c. Lubricate properly. 	<ul style="list-style-type: none"> 6-1/9-1 --- 6-1
5. The buzzer does not sound when the machine cycles off.	<ul style="list-style-type: none"> a. The buzzer is malfunctioning. 	<ul style="list-style-type: none"> a. Contact service technician to replace the buzzer. 	<ul style="list-style-type: none"> ---

Section 9

Parts Replacement Schedule

Table 9-1

Part Description	Every 3 Months	Every 4 Months	Every 6 Months	Annually	Qty
Driveshaft Seal	X				1
Scraper Blades		X	Minimum		2
Freezer Door O-ring	X				1
Draw Plate O-ring	X				1
White Bristle Brush, 3" x 7"			Inspect and replace if necessary.	Minimum	1
White Bristle Brush, 1-1/2 x 2"			Inspect and replace if necessary.	Minimum	1
Black Bristle Brush, 1" x 2"			Inspect and replace if necessary.	Minimum	1

TAYLOR COMPANY LIMITED WARRANTY ON FREEZERS

Taylor Company is pleased to provide this limited warranty on new Taylor-branded freezer equipment available from Taylor to the market generally (the "Product") to the original purchaser only.

LIMITED WARRANTY

Taylor warrants the Product against failure due to defect in materials or workmanship under normal use and service as follows. All warranty periods begin on the date of original Product installation. If a part fails due to defect during the applicable warranty period, Taylor, through an authorized Taylor distributor or service agency, will provide a new or remanufactured part, at Taylor's option, to replace the failed defective part at no charge for the part. Except as otherwise stated herein, these are Taylor's exclusive obligations under this limited warranty for a Product failure. This limited warranty is subject to all provisions, conditions, limitations, and exclusions listed below and on the reverse (if any) of this document.

Table 10-1

Product	Part	Limited Warranty Period
Soft Serve	Insulated shell assembly	Five (5) years
Frozen Yogurt Shakes	Refrigeration compressor (except service valve)	Five (5) years
Smoothies	Beater motors	Two (2) years
Frozen Beverage	Beater drive gear	Two (2) years
Batch Desserts	Printed circuit boards and Softech controls beginning with serial number H8024200	Two (2) years
	Parts not otherwise listed in this table or excluded below	One (1) years

LIMITED WARRANTY CONDITIONS

1. If the date of original installation of the Product cannot be verified, then the limited warranty period begins ninety (90) days from the date of Product manufacture (as indicated by the Product serial number). Proof of purchase may be required at time of service.
2. This limited warranty is valid only if the Product is installed and all required service work on the Product is performed by an authorized Taylor distributor or service agency, and only if genuine, new Taylor parts are used.
3. Installation, use, care, and maintenance must be normal and in accordance with all instructions contained in the Taylor Operator's Manual.
4. Defective parts must be returned to the authorized Taylor distributor or service agency for credit.
5. The use of any refrigerant other than that specified on the Product's data label will void this limited warranty.

LIMITED WARRANTY EXCEPTIONS

This limited warranty does **not** cover:

1. Labor or other costs incurred for diagnosing, repairing, removing, installing, shipping, servicing, or handling of defective parts, replacement parts, or new Products.
2. Normal maintenance, cleaning, and lubrication as outlined in the Taylor Operator's Manual, including cleaning of condensers.
3. Replacement of wear items designated as Class "000" parts in the Taylor Operator's Manual.

LIMITED WARRANTY ON EQUIPMENT

4. External hoses, electrical power supplies, and machine grounding.
5. Parts not supplied or designated by Taylor, or damages resulting from their use.
6. Return trips or waiting time required because a service technician is prevented from beginning warranty service work promptly upon arrival.
7. Failure, damage, or repairs due to faulty installation, misapplication, abuse, no or improper servicing, unauthorized alteration or improper operation or use as indicated in the Taylor Operator's Manual, including but not limited to the failure to use proper assembly and cleaning techniques, tools, or approved cleaning supplies.
8. Failure, damage, or repairs due to theft, vandalism, wind, rain, flood, high water, water, lightning, earthquake, or any other natural disaster, fire, corrosive environments, insect or rodent infestation, or other casualty, accident or condition beyond the reasonable control of Taylor; operation above or below the electrical or water supply specification of the Product; or components repaired or altered in any way so as, in the judgment of the Manufacturer, to adversely affect performance, or normal wear or deterioration.
9. Any Product purchased over the Internet.
10. Failure to start due to voltage conditions, blown fuses, open circuit breakers, or damages due to the inadequacy or interruption of electrical service.
11. Electricity or fuel costs, or increases in electricity or fuel costs from any reason whatsoever.
12. Damages resulting from the use of any refrigerant other than that specified on the Product's data label will void this limited warranty.
13. Any cost to replace, refill, or dispose of refrigerant, including the cost of refrigerant.
- 14. ANY SPECIAL, INDIRECT, OR CONSEQUENTIAL PROPERTY OR COMMERCIAL DAMAGE OF ANY NATURE WHATSOEVER.** Some jurisdictions do not allow the exclusion of incidental or consequential damages, so this limitation may not apply to you.

This limited warranty gives you specific legal rights, and you may also have other rights which vary from jurisdiction to jurisdiction.

LIMITATION OF WARRANTY

THIS LIMITED WARRANTY IS EXCLUSIVE AND IS IN LIEU OF ALL OTHER WARRANTIES, CONDITIONS, AND/OR REMEDIES UNDER THE LAW, INCLUDING ANY IMPLIED WARRANTIES OR CONDITIONS OF MERCHANTABILITY OR FITNESS FOR A PARTICULAR PURPOSE. THE ORIGINAL OWNER'S SOLE REMEDY WITH RESPECT TO ANY PRODUCTS SHALL BE REPAIR OR REPLACEMENT OF DEFECTIVE COMPONENTS UNDER THE TERMS OF THIS LIMITED WARRANTY. ALL RIGHTS TO CONSEQUENTIAL OR INCIDENTAL DAMAGES (INCLUDING CLAIMS FOR LOST SALES, LOST PROFITS, PRODUCT LOSS, PROPERTY DAMAGES, OR SERVICE EXPENSES) ARE EXPRESSLY EXCLUDED. THE EXPRESS WARRANTIES MADE IN THIS LIMITED WARRANTY MAY NOT BE ALTERED, ENLARGED, OR CHANGED BY ANY DISTRIBUTOR, DEALER, OR OTHER PERSON, WHATSOEVER.

LEGAL REMEDIES

The owner **must** notify Taylor in writing, by certified or registered letter to the following address, of any defect or complaint with the Product, stating the defect or complaint and a specific request for repair, replacement, or other correction of the Product under warranty, mailed at least thirty (30) days before pursuing any legal rights or remedies.

Taylor Company
750 N. Blackhawk Blvd.
Rockton, IL 61072, U.S.A.

TAYLOR COMPANY LIMITED WARRANTY ON GENUINE TAYLOR PARTS

Taylor Company is pleased to provide this limited warranty on new Taylor genuine replacement components and parts available from Taylor to the market generally (the “Parts”) to the original purchaser only.

LIMITED WARRANTY

Taylor warrants the Parts against failure due to defect in materials or workmanship under normal use and service as follows. All warranty periods begin on the date of original installation of the Part in the Taylor unit. If a Part fails due to defect during the applicable warranty period, Taylor, through an authorized Taylor distributor or service agency, will provide a new or remanufactured Part, at Taylor’s option, to replace the failed defective Part at no charge for the Part. Except as otherwise stated herein, these are Taylor’s exclusive obligations under this limited warranty for a Part failure. This limited warranty is subject to all provisions, conditions, limitations, and exclusions listed below and on the reverse (if any) of this document.

Table 11-1

Parts Warranty Class Code Or Part	Limited Warranty Period
Class 103 Parts ¹	Three (3) Months
Class 212 Parts ²	Twelve (12) Months
Class 512 Parts	Twelve (12) Months
Class 000 Parts	No Warranty

LIMITED WARRANTY CONDITIONS

1. If the date of original installation of the Part cannot be otherwise verified, proof of purchase may be required at time of service.
2. This limited warranty is valid only if the Part is installed and all required service work in connection with the Part is performed by an authorized Taylor distributor or service agency.
3. The limited warranty applies only to Parts remaining in use by their original owner at their original installation location in the unit of original installation.
4. Installation, use, care, and maintenance must be normal and in accordance with all instructions contained in the Taylor Operator’s Manual.
5. Defective Parts must be returned to the authorized Taylor distributor or service agency for credit.
6. This warranty is not intended to shorten the length of any warranty coverage provided pursuant to a separate Taylor Limited Warranty on freezer or grill equipment.
7. The use of any refrigerant other than that specified for the unit in which the Part is installed will void this limited warranty.

^{1, 2} Except that Taylor Part #032129SER2 (Compressor-Air-230V SERV) and Taylor Part #075506SER1 (Compressor-Air-115V 60HZ) shall have a limited warranty period of twelve (12) months when used in Taylor freezer equipment and a limited warranty period of two (2) years when used in Taylor grill equipment.

LIMITED WARRANTY ON PARTS

LIMITED WARRANTY EXCEPTIONS

This limited warranty does **not** cover:

1. Labor or other costs incurred for diagnosing, repairing, removing, installing, shipping, servicing, or handling of defective Parts, replacement Parts, or new Parts.
2. Normal maintenance, cleaning, and lubrication as outlined in the Taylor Operator's Manual, including cleaning of condensers or carbon and grease buildup.
3. Required service, whether cleaning or general repairs, to return the cooking surface assemblies, including the upper platen and lower plate, to an operational condition to achieve proper cooking or allow proper assembly of release sheets and clips as a result of grease buildup on the cooking surfaces, including but not limited to the platen and plate, sides of the shroud, or top of the shroud.
4. Replacement of cooking surfaces, including the upper platen and lower plate, due to pitting or corrosion (or in the case of the upper platen, due to loss of plating) as a result of damage due to the impact of spatulas or other small wares used during the cooking process or as a result of the use of cleaners, cleaning materials, or cleaning processes not approved for use by Taylor.
5. Replacement of wear items designated as Class "000" Parts in the Taylor Operator's Manual, as well as any release sheets and clips for the Product's upper platen assembly.
6. External hoses, electrical power supplies, and machine grounding.
7. Parts not supplied or designated by Taylor, or damages resulting from their use.
8. Return trips or waiting time required because a service technician is prevented from beginning warranty service work promptly upon arrival.
9. Failure, damage, or repairs due to faulty installation, misapplication, abuse, no or improper servicing, unauthorized alteration, or improper operation or use as indicated in the Taylor Operator's Manual, including but not limited to the failure to use proper assembly and cleaning techniques, tools, or approved cleaning supplies.
10. Failure, damage, or repairs due to theft, vandalism, wind, rain, flood, high water, water, lightning, earthquake, or any other natural disaster, fire, corrosive environments, insect or rodent infestation, or other casualty, accident, or condition beyond the reasonable control of Taylor; operation above or below the gas, electrical, or water supply specification of the unit in which a part is installed; or Parts or the units in which they are installed, repaired, or altered in any way so as, in the judgment of Taylor, to adversely affect performance, normal wear, or deterioration.
11. Any Part purchased over the Internet.
12. Failure to start due to voltage conditions, blown fuses, open circuit breakers, or damages due to the inadequacy or interruption of electrical service.
13. Electricity, gas, or other fuel costs, or increases in electricity or fuel costs from any reason whatsoever.
14. Damages resulting from the use of any refrigerant other than that specified for the unit in which the Part is installed will void this limited warranty.
15. Any cost to replace, refill, or dispose of refrigerant, including the cost of refrigerant.
16. **ANY SPECIAL, INDIRECT, OR CONSEQUENTIAL PROPERTY OR COMMERCIAL DAMAGE OF ANY NATURE WHATSOEVER.** Some jurisdictions do not allow the exclusion of incidental or consequential damages, so this limitation may not apply to you.

This limited warranty gives you specific legal rights, and you may also have other rights which vary from jurisdiction to jurisdiction.

LIMITATION OF WARRANTY

THIS LIMITED WARRANTY IS EXCLUSIVE AND IS IN LIEU OF ALL OTHER WARRANTIES, CONDITIONS, AND/OR REMEDIES UNDER THE LAW, INCLUDING ANY IMPLIED WARRANTIES OR CONDITIONS OF MERCHANTABILITY OR FITNESS FOR A PARTICULAR PURPOSE. THE ORIGINAL OWNER'S SOLE REMEDY WITH RESPECT TO ANY PRODUCTS SHALL BE REPAIR OR REPLACEMENT OF DEFECTIVE PARTS UNDER THE TERMS OF THIS LIMITED WARRANTY. ALL RIGHTS TO CONSEQUENTIAL OR INCIDENTAL DAMAGES (INCLUDING CLAIMS FOR LOST SALES, LOST PROFITS, PRODUCT LOSS, PROPERTY DAMAGES, OR SERVICE EXPENSES) ARE EXPRESSLY EXCLUDED. THE EXPRESS WARRANTIES MADE IN THIS LIMITED WARRANTY MAY NOT BE ALTERED, ENLARGED, OR CHANGED BY ANY DISTRIBUTOR, DEALER, OR OTHER PERSON, WHATSOEVER.

LEGAL REMEDIES

The owner **must** notify Taylor in writing, by certified or registered letter to the following address, of any defect or complaint with the Part, stating the defect or complaint and a specific request for repair, replacement, or other correction of the Part under warranty, mailed at least thirty (30) days before pursuing any legal rights or remedies.

Taylor Company
750 N. Blackhawk Blvd.
Rockton, IL 61072, U.S.A.

