

# OPERATOR'S MANUAL



## Model 345, 346, 349, & 355 Slush Freezers

Original Operating Instructions

039710-M

06/19/01 (Original Publication)  
(Updated 2/4/2019)



## Section 1: To the Installer

Installer Safety . . . . .	1-1
Site Preparation . . . . .	1-1
Air-Cooled Machines . . . . .	1-1
Water-Cooled Refrigeration Machines . . . . .	1-2
Water Connections . . . . .	1-3
Electrical Connections . . . . .	1-3
Beater Rotation . . . . .	1-4
Initial Freezing Cylinder Cleaning . . . . .	1-4
Refrigerant . . . . .	1-4
Syrup System Connections . . . . .	1-5

## Section 2: To the Operator

Compressor Warranty Disclaimer . . . . .	2-2
--	-----

## Section 3: Safety

## Section 4: Operator Parts Identification

## Section 5: User Interface

Symbol Definitions (Model 349 Only) . . . . .	5-2
Control Switch . . . . .	5-2
Liquid Crystal Display . . . . .	5-2
Operational Mode Display . . . . .	5-2
Operator Menu Display . . . . .	5-3
Operator Menu Timeout . . . . .	5-3
Finding Current Fault Conditions . . . . .	5-3
Setting the Clock . . . . .	5-5
Manual Defrosting . . . . .	5-5
Current System Information . . . . .	5-5
Current Conditions . . . . .	5-7
Searching Fault History . . . . .	5-7
Service Information . . . . .	5-7
Syrup Out Indicator . . . . .	5-7
CO <sub>2</sub> Out Indicator . . . . .	5-8
Water Out Indicator . . . . .	5-8
Audio Alarm Silencer . . . . .	5-8
Product Light . . . . .	5-8
Sampling Valve . . . . .	5-8
Daily Procedures . . . . .	5-8

# Table of Contents

---

## Section 6: Operating Procedures

Assembly .....	6-1
Sanitizing .....	6-6
Priming/Brixing .....	6-10
90 Day Closing Procedure .....	6-12
Draining Product from the Freezing Cylinder .....	6-12
Cleaning .....	6-12
Disassembly .....	6-13
Brush Cleaning .....	6-13

## Section 7: Operator Checklist

During Cleaning and Sanitizing .....	7-1
Troubleshooting Bacterial Count .....	7-1
Regular Maintenance Checks .....	7-1
Winter Storage .....	7-2

## Section 8: Troubleshooting Guide

## Section 9: Parts Replacement Schedule

## Section 10: Limited Warranty on Equipment

## Section 11: Limited Warranty on Parts

The following information has been included in the manual as safety and regulatory guidelines. For complete installation instructions, please see the installation checklist.

## Installer Safety



**IMPORTANT!** *In all areas of the world, the machine should be installed in accordance with existing local codes. Please contact your local authorities if you have any questions.*

*Care should be taken to ensure that all basic safety practices are followed during the installation and servicing activities related to the installation and service of Taylor® machines.*

- Only authorized Taylor service personnel should perform installation, maintenance, and repairs on Taylor machines.
- Authorized service personnel should consult OSHA Standard 29CFR1910.147 or the applicable code of the local area for the industry standards on lockout/tagout procedures before beginning any installation or repairs.
- Authorized service personnel must ensure that the proper personal protective equipment (PPE) is available and worn when required during installation and service.
- Authorized service personnel must remove all metal jewelry, rings, and watches before working on electrical equipment.



**DANGER!** The main power supply(s) to the machine must be disconnected prior to performing any installation, maintenance, or repairs. Failure to follow this instruction may result in personal injury or death from electrical shock or hazardous moving parts, as well as poor performance or damage to the machine.

**Note:** *All repairs must be performed by an authorized Taylor service technician.*



**WARNING!** This machine has many sharp edges that can cause severe injuries.

## Site Preparation

Review the area the machine is to be installed in before uncrating the machine, making sure that all possible hazards the user or machine may come into have been addressed.



**WARNING!** Only install this machine in a location where its use and maintenance is restricted to trained personnel. Failure to comply may result in personal injury.

## Air-Cooled Machines

Air-cooled machines require 6 in. (152 mm) minimum air space around all sides of the freezer to allow for adequate air flow across the condenser(s). Failure to allow adequate clearance can reduce the refrigeration capacity of the freezer and possibly cause permanent damage to the compressor.

**For Indoor Use Only:** This machine is designed to operate indoors, under normal ambient temperatures of 70°F to 75°F (21°C to 24°C). The freezer has successfully performed in high ambient temperatures of 104°F (40°C) at reduced capacities.



**WARNING!** This machine must **NOT** be installed in an area where a water jet or hose can be used. **NEVER** use a water jet or hose to rinse or clean the machine. Failure to follow this instruction may result in electrocution.



**CAUTION!** This machine must be installed on a level surface to avoid the hazard of tipping. Extreme care should be taken in moving this machine for any reason. Two or more persons are required to safely move this machine. Failure to comply may result in personal injury or damage to the machine.

The authorized installer should inspect the machine for damage and promptly report any damage to the local authorized Taylor distributor.

This machine is made using USA sizes of hardware. All metric conversions are approximate and vary in size.

## Water-Cooled Refrigeration Machines (Water-Cooled Machines Only)

Failure to use adequately sized water lines may cause the machine to go off on high head pressure and shut down. Depending on local water conditions, it may be advisable to install a water strainer to prevent foreign substances from clogging the automatic water valve.

There are two water-in connections and one water-out connection. **Do not** install a hand shutoff valve on the water-out line. Water should always flow in this order: first, through the automatic water valve; second, through the condenser; and third, through the outlet fitting to an open trap drain.

**Important!** Water pressures are pre-set at the factory. **Do not** adjust the water. Improper water adjustments may cause operation discrepancies.



**IMPORTANT!** A backflow prevention device is required on the incoming water connection side. Please see the applicable national, state, and local codes for determining the proper configuration.

## Water Connections

An adequate cold water supply must be provided with a hand shutoff valve. On the back of the machine, a 3/8 in. (9.5 mm) M.F.L. water connection has been provided for easy hook-up. A flexible line is recommended, if local codes permit. A minimum of 25 psi water pressure is required to avoid having the machine cut out the low water pressure switch. A booster pump must be provided if this pressure is not available.

**Note:** Water lines beyond 200 ft. (61 m) require 1/2 in. (13 mm) water lines.



**INSTALL POTABLE WATER CONNECTION WITH ADEQUATE BACKFLOW PROTECTION TO COMPLY WITH APPLICABLE FEDERAL, STATE AND LOCAL CODES.**

It is always a good practice to have a filter system to improve the quality of the water and to avoid clogging the operating components.

**Important!** The water filter (064422-SER) must be thoroughly flushed with water before connecting it to the machine. This removes carbon particles that could clog the flow control. To flush the filter, connect the inlet end of the filter to the water supply. Position the outlet end of the filter over an empty pail. Open the water supply. Allow water to flow through the filter until the water exiting the filter is clear. Close the water supply. Attach the outlet end of the filter to the machine. Reopen the water supply.

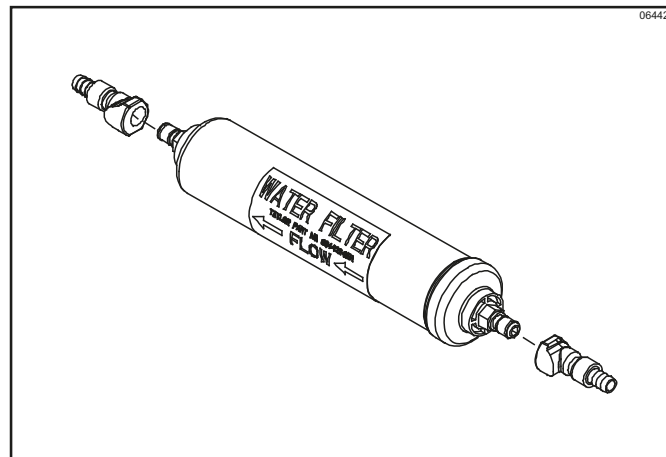

Figure 1-1

## Electrical Connections

In the United States, this machine is intended to be installed in accordance with the National Electrical Code (NEC), ANSI/NFPA 70-1987. The purpose of the NEC is the practical safeguarding of persons and property from hazards arising from the use of electricity. This code contains provisions considered necessary for safety. Compliance therewith and proper maintenance will result in an installation essentially free from hazard. In all other areas of the world, machines should be installed in accordance with the existing local codes. Please contact your local authorities.



**FOLLOW YOUR LOCAL ELECTRICAL CODES.**

Each freezer requires one power supply. Check the data label on the freezer for branch circuit overcurrent protection or fuse, circuit ampacity, and electrical specifications. See the wiring diagram provided inside the control box for proper power connections.



**WARNING!** This machine must be properly grounded. Failure to do so can result in severe personal injury from electrical shock.



**WARNING! DO NOT** operate this freezer with larger fuses than specified on the unit data label. Failure to follow this instruction may result in electrocution or damage to the machine.



**IMPORTANT!** An equipotential grounding lug is provided with this machine. Some countries require the grounding lug to be properly attached to the rear of the frame by the authorized installer. The installation location is marked by the equipotential bonding symbol (5021 of IEC 60417-1) on both the removable panel and the machine's frame.



### **IMPORTANT!**

- *Stationary machines which are not equipped with a power cord and a plug or another device to disconnect the machine from the power source must have an all-pole disconnecting device with a contact gap of at least 0.125 in. (3 mm) installed in the external installation.*
- *Machines that are permanently connected to fixed wiring and for which leakage currents may exceed 10 mA, particularly when disconnected or not used for long periods, or during initial installation, shall have protective devices to protect against the leakage of current, such as a GFI, installed by the authorized personnel to the local codes.*
- *Supply cords used with this machine shall be oil-resistant, sheathed flexible cable not lighter than ordinary polychloroprene or other equivalent synthetic elastomer-sheathed cord (code designation 60245 IEC 57) installed with the proper cord anchorage to relieve conductors from strain, including twisting, at the terminals and protect the insulation of the conductors from abrasion.*

*If the supply cord is damaged, it must be replaced by an authorized Taylor service technician in order to avoid a hazard.*

## Beater Rotation



**NOTICE!** Beater rotation must be clockwise as viewed looking into the freezing cylinder.

To correct the rotation on a three-phase machine, interchange any two incoming power supply lines at the machine main terminal block only. To correct rotation on a single-phase machine, exchange leads inside the beater motor. (Follow the diagram printed on the motor.)

Electrical connections are made directly to the terminal block provided in the main control box located behind the service panel.

It is recommended that beater rotation adjustment be performed by an authorized Taylor service technician.

**Note:** The following procedures must be performed by an authorized Taylor service technician.

### Initial Freezing Cylinder Cleaning

1 Due to the types of products used in FCB equipment, it is imperative that the freezing cylinder and the inlet tube be thoroughly brush-cleaned, rinsed, and sanitized before running any product.

Prepare a cleaning solution, using 2 oz. of liquid detergent in 2 gal. of warm water. Using this solution, brush-clean the freezing cylinder and the inlet tube. Rinse the freezing cylinder and the inlet tube with clean water and then sanitize, using the sanitizing procedures outlined in this Operator Manual, starting on page 6-6.

### Refrigerant



**CAUTION!** This equipment contains fluorinated greenhouse gases (F-Gas) to provide refrigeration using a hermetically sealed circuit or within foam insulation. This unit's type of gas, quantity, Global Warming Potential (GWP) and CO<sub>2</sub> tonnes equivalent information are recorded on the unit's data-label. The refrigerant used is generally considered non-toxic and non-flammable. However any gas under pressure is potentially hazardous and must be handled with caution.

**NEVER** fill any refrigerant cylinder completely with liquid. Filling the cylinder to approximately 80% will allow for normal expansion



**CAUTION!** Use only approved refrigerant listed on the unit's data label or authorized through a manufacturer's technical bulletin. The use of any other refrigerant may expose users and operators to unexpected safety hazards.



**IMPORTANT!** Refrigerants and their associated lubricants may be extremely moisture absorbent. When opening a refrigeration system, the maximum time the system is open must not exceed 15 minutes. Cap all open tubing to prevent humid air or water from being absorbed by the oil.



**WARNING!** Refrigerant liquid sprayed onto the skin may cause serious damage to tissue. Keep eyes and skin protected. If refrigerant burns should occur, flush them immediately with cold water. If burns are severe, apply ice packs and contact a physician immediately.



**NOTICE!** Taylor reminds technicians to be aware of and in compliance with local government laws regarding refrigerant recovery, recycling, and reclaiming systems. For information regarding applicable local laws, please contact your local authorized Taylor distributor.

### Syrup System Connections

1. Water pipe connections and fixtures directly connected to a potable water supply shall be sized, installed, and maintained according to federal, state, and local laws.
2. Hook up the cold water supply to the freezer to supply water to the carbonator. A minimum of 21 psi (1.45 bar) of water pressure is required at the low-pressure switch. The low-pressure switch will cause the entire freezer to shut down if the water pressure drops below 7 psi (0.483 bar) for longer than 1 minute.

The water regulator should be set at 35 PSI (2.41 bar). When the power switch is turned on the water pump will immediately activate to maintain water pressure.

3. For Electrical Hookup Specifications:

- One power cord.
- Refer to the data label.
- Make sure all control switches on the front panel are in the OFF position.
- The freezer must be properly grounded.

4. A harness with three Nylobrade® tubes feeds through the base pan and exits the rear of the freezer.

**Note:** The Model 355 is equipped with four tubes.

a. Connect the CO<sub>2</sub> line to the CO<sub>2</sub> regulator that is closest to the CO<sub>2</sub> tank (primary regulator). This line will supply CO<sub>2</sub> to the freezer.

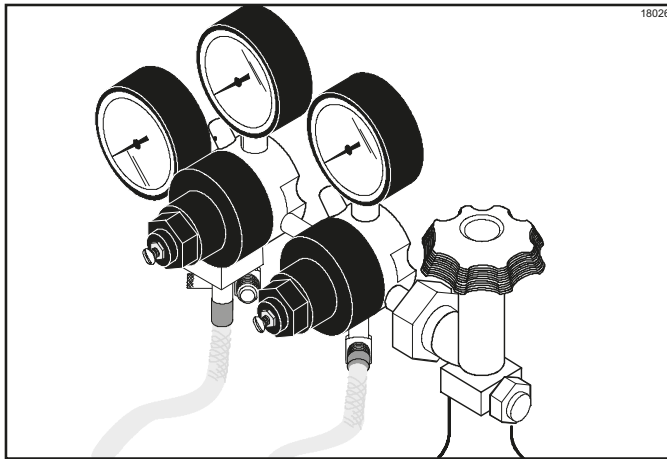

Figure 1-2

b. Connect the #1 line to the syrup tank for the left side of the freezer as viewed from the front of the machine. This line will supply syrup to the left syrup sentry.

**Note:** For Bag-in-Box (BIB) machines, connect the #1 line to the Bag-in-Box instead of the syrup tank.

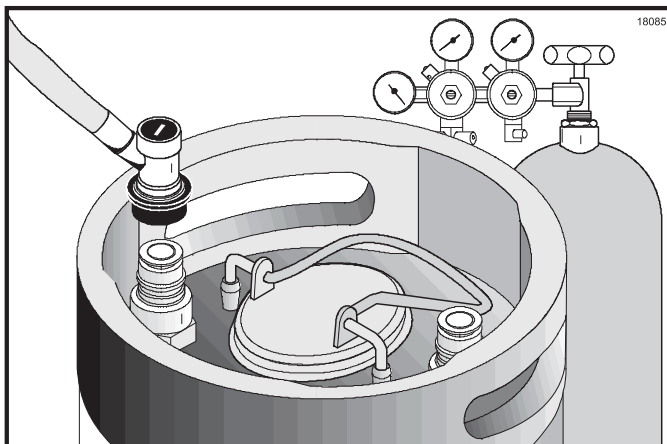

Figure 1-3

- Connect the #2 line to the syrup tank (or the Bag-in-Box) for the right side of the freezer. This line will supply syrup to the right syrup sentry.
  - Connect the #4 line on the Model 355 to the water regulator on the remote carbonator. This line monitors the water pressure supplied to the unit.
5. There are two spare CO<sub>2</sub> lines provided. Use one of the spare CO<sub>2</sub> lines to connect one end to the individual regulator (secondary regulator) and the other end to the first syrup tank. Use the other spare CO<sub>2</sub> line to connect the CO<sub>2</sub> to the second syrup tank.

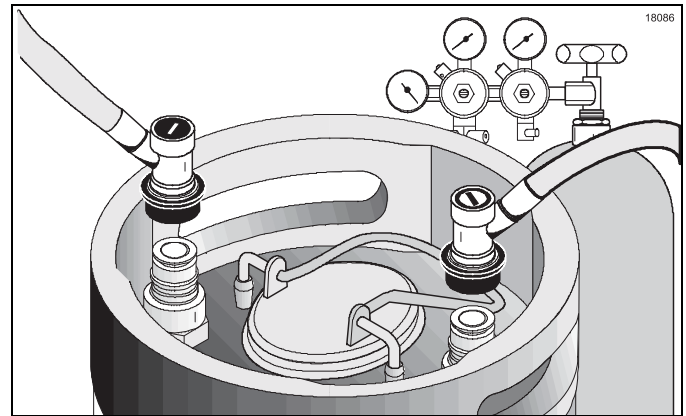

Figure 1-4

**Note:** For Bag-in-Box machines, connect the CO<sub>2</sub> lines to the Bag-in-Box pumps instead of the syrup tanks.

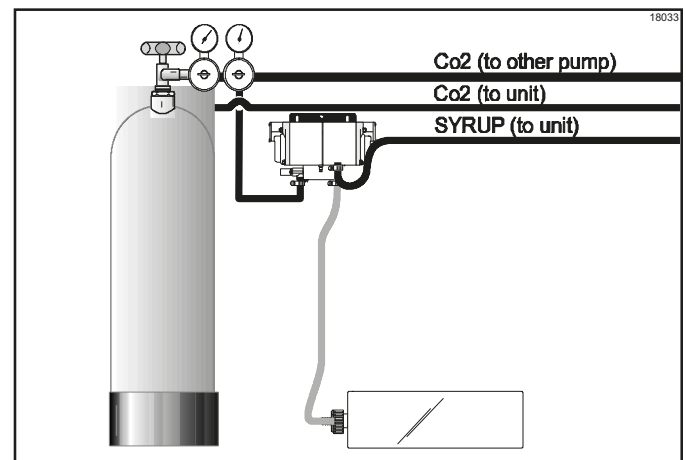

Figure 1-5

6. Set the primary regulator on the CO<sub>2</sub> tank to 90 psi (6.2 bar).

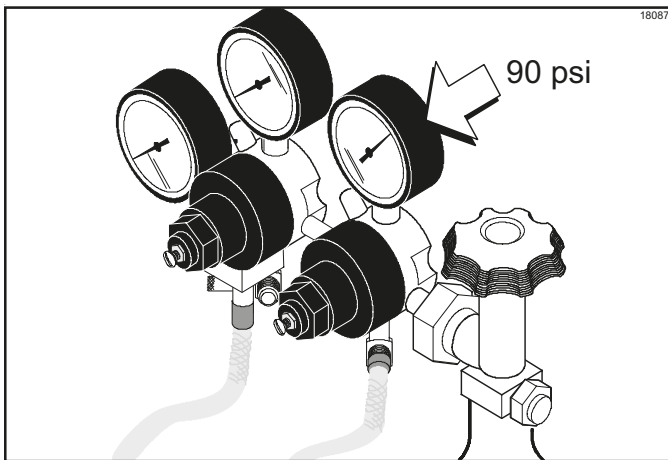

Figure 1-6

7. Set the secondary regulator on the CO<sub>2</sub> tank to 60 psi (4.1 bar) for the syrup tanks or the BIB pumps

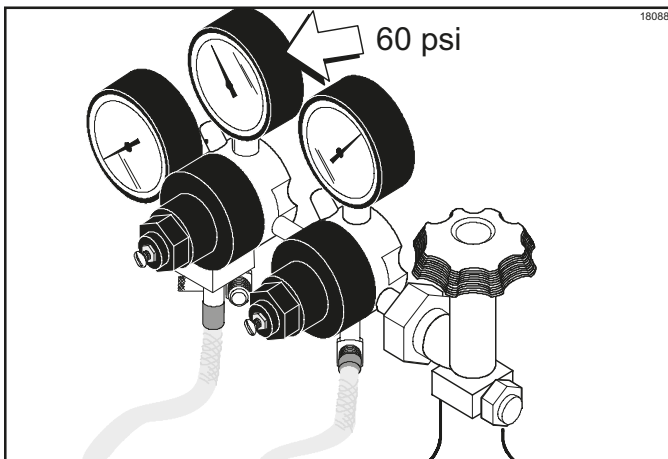

Figure 1-7

8. Turn the cold water supply on.
9. Check for CO<sub>2</sub> leaks. This can be done by closing the valve on the top of the CO<sub>2</sub> tank. Watch the high pressure gauge; it should hold pressure. If it does not, there is a CO<sub>2</sub> leak. Use a soap solution to locate and repair the leak.

10. For the Bag-in-Box syrup delivery system, connect the two spare CO<sub>2</sub> lines from the secondary regulator to each Gas In fitting on the pumps. Set secondary regulator pressure to 60 psi (4.1 bar) depending on the length of syrup line run to the unit.

**Important!** Make sure the Bag-in-Box switch is enabled.

11. The CO<sub>2</sub> regulator assembly (primary regulator) inside the freezer should be set at 60 psi (4.1 bar). The secondary regulator, located inside the freezer just behind the primary regulator, can be adjusted from 20 psi to 25 psi (1.38 bar to 1.72 bar). (The factory recommendation is 20 psi [1.38 bar].) Increasing the pressure from 20 psi (1.38 bar) will increase the overrun. You should always stay within the 20 psi to 25 psi (1.38 bar to 1.72 bar) range as the gauge reflects the pressure in the hopper and barrel. The setting will be determined by the desired overrun and the syrup used.
12. The CO<sub>2</sub> low pressure switch requires at least 74 psi (5.1 bar) before the freezer will start. It is set to cut out at 60 psi (4.1 bar) and in at 74 psi (5.1 bar).
13. The pressure relief valve on the hopper cover is set to relieve at 30 psi (2.0 bar) in case of excess pressure in the hopper.
14. There are check valves in the CO<sub>2</sub>, syrup, and water lines to prevent any back flow of soda water, product, or CO<sub>2</sub>.
15. The CO<sub>2</sub> solenoids which supply CO<sub>2</sub> to the hoppers are wired to provide CO<sub>2</sub> in all control settings except DEFROST and OFF.

The freezer(s) you have purchased has been carefully engineered and manufactured to give you dependable operation.

This machine(s), when properly operated and cared for, will produce a consistent quality product. Like all mechanical products, this machine will require cleaning and scheduled maintenance. A minimum amount of care and attention is necessary if the operating procedures outlined in this manual are followed closely.



**IMPORTANT!** This manual should be read before operating or performing any maintenance on the machine.

Your Taylor machine will **NOT** compensate for and/or correct any errors made during the setup or filling operations. Thus, the initial assembly, setup, and priming procedures are of extreme importance. It is strongly recommended that all personnel responsible for the machine's operation, including assembly and disassembly, go through these procedures together in order to be properly trained and to make sure that all personnel understand their role in using and maintaining the machine.

If you should require technical assistance, please contact your local authorized Taylor distributor.

**Note:** Your Taylor warranty is valid only if the parts are authorized Taylor parts, purchased from the local authorized Taylor distributor, and only if all required service work is provided by an authorized Taylor service technician. Taylor reserves the right to deny warranty claims on machines or parts if unapproved parts or incorrect refrigerant were installed in the machine, system modifications were performed beyond factory recommendations, or it is determined that the failure was caused by abuse, misuse, neglect, or failure to follow all operating instructions. For full details of your Taylor warranty, please see the Limited Warranty section in this manual.

**Note:** Constant research results in steady improvements; therefore, information in this manual is subject to change without notice.



**IMPORTANT!** If the crossed-out wheeled-bin symbol is affixed to this machine, it signifies that this machine is compliant with the EU Directives as well as other similar end-of-life legislation in effect after August 13, 2005. Therefore, it must be collected separately after its use is completed and cannot be disposed as unsorted municipal waste.

The user is responsible for delivering the machine to the appropriate collection facility, as specified by your local code.

For additional information regarding applicable local disposal laws, please contact the municipal waste facility and/or local authorized Taylor distributor.

### Compressor Warranty Disclaimer

2 The refrigeration compressor(s) on this machine are warranted for the term stated in the Limited Warranty section in this manual. However, due to the Montreal Protocol and the U.S. Clean Air Act Amendments of 1990, many new refrigerants are being tested and developed, thus seeking their way into the service industry. Some of these new refrigerants are being advertised as drop-in replacements for numerous applications. It should be noted that in the event of ordinary service to this unit's refrigeration system, only the refrigerant specified on the affixed data label should be used. The unauthorized use of alternate refrigerants will void your Taylor compressor warranty. It is the machine owner's responsibility to make this fact known to any technician he or she employs.

It should also be noted that Taylor does not warrant the refrigerant used in its equipment. For example, if the refrigerant is lost during the course of ordinary service to this machine, Taylor has no obligation to either supply or provide its replacement either at billable or unbillable terms. Taylor does have the obligation to recommend a suitable replacement if the original refrigerant is banned, obsoleted, or no longer available during the 5-year warranty of the compressor.

Taylor will continue to monitor the industry and test new alternates as they are being developed. Should a new alternate prove, through our testing, that it would be accepted as a drop-in replacement, then the above disclaimer would become null and void. To find out the current status of an alternate refrigerant as it relates to your compressor warranty, call the local Taylor distributor or the Taylor factory. Be prepared to provide the model/serial number of the machine in question.

We at Taylor Company are concerned about the safety of the operator when he or she comes in contact with the freezer and its parts. Taylor has gone to extreme efforts to design and manufacture built-in safety features to protect both you and the service technician. As an example, warning labels have been attached to the freezer to further point out safety precautions to the operator.



**DANGER!** Failure to adhere to the following safety precautions may result in severe personal injury or death. Failure to comply with these warnings may also damage the machine and/or its components. Such damage may require component replacement and service repair expenses.



**NOTICE! DO NOT** operate this machine without reading this entire manual first. Failure to follow all of these operating instructions may result in damage to the machine, poor performance, health hazards, or personal injury.



**IMPORTANT!** *This machine is to be used only by trained personnel. It is not intended for use by children or people with reduced physical, sensory, or mental capabilities, or lack of experience and knowledge. Where limited machine operation is allowed for public use, such as a self-serve application, supervision or instruction concerning the use of the machine by a person responsible for their safety is required. Children should be supervised to ensure that they do not play with the machine.*



**WARNING! DO NOT** use a water jet to clean or rinse the machine. Failure to follow these instructions may result in serious electrical shock.



**WARNING!** Avoid injury.

- **DO NOT** operate the machine unless it is properly grounded.
- **DO NOT** operate the machine with larger fuses than specified on the machine's data label.
- All repairs should be performed by an authorized Taylor service technician.
- The main power supplies to the machine must be disconnected prior to performing installation, repairs, or maintenance.
- Machines that are permanently connected to fixed wiring and for which leakage currents may exceed 10 mA, particularly when disconnected or not used for long periods, or during initial installation, shall have protective devices to protect against the leakage of current, such as a GFI, installed by the authorized personnel to the local codes.
- Stationary machines which are not equipped with a power cord and a plug or another device to disconnect the machine from the power source must have an all-pole disconnecting device with a contact gap of at least 0.125 in. (3 mm) installed in the external installation.
- Supply cords used with this machine shall be oil-resistant, sheathed flexible cable not lighter than ordinary polychloroprene or other equivalent synthetic elastomer-sheathed cord (code designation 60245 IEC 57) installed with the proper cord anchorage to relieve conductors from strain, including twisting, at the terminals and protect the insulation of the conductors from abrasion.
- If the supply cord is damaged, it must be replaced by an authorized Taylor service technician in order to avoid a hazard.

Failure to follow these instructions may result in electrocution. Contact your local authorized Taylor distributor for service.



**IMPORTANT!** An equipotential grounding lug is provided with this machine. Some countries require the grounding lug to be properly attached to the rear of the frame by the authorized installer. The installation location is marked by the equipotential bonding symbol (5021 of IEC 60417-1) on both the removable panel and the machine's frame.



**WARNING!** Avoid injury.

- **DO NOT** allow untrained personnel to operate this machine.
- **DO NOT** operate the machine unless all service panels and access doors are restrained with screws.
- **DO NOT** remove any internal operating parts (including, but not limited to, machine door, beater, or scraper blades), unless all control switches are in the OFF position.

Failure to follow these instructions may result in severe personal injury, especially to fingers or hands, from hazardous moving parts.



**WARNING!** This machine has many sharp edges that can cause severe injuries.

- **DO NOT** put objects or fingers in the door spout. This may contaminate the product and cause severe personal injury from blade contact.
- **USE EXTREME CAUTION** when removing the beater assembly. The scraper blades are very sharp.



**CAUTION!** This machine must be placed on a level surface. Extreme care should be taken when moving it for any reason. Two or more persons are required to safely move this machine. Failure to comply may result in personal injury or damage to the machine.



**IMPORTANT!** Access to the service area of the machine must be restricted to persons having knowledge and practical experience with the machine, in particular as far as safety and hygiene are concerned.



**NOTICE!** Cleaning and sanitizing schedules are governed by your federal, state, or local regulatory agencies and must be followed accordingly. Please refer to the cleaning section of this manual for the proper procedure to clean this machine.



**CAUTION!** This machine is equipped with a refrigerated cabinet, designed to maintain product temperature at or below 41°F (5°C). Before replenishing the mix supply, the product must be refrigerated at or below 41°F (5°C). Failure to follow this instruction may result in health hazards and poor machine performance.

**DO NOT** run the machine without product. Failure to follow this instruction can result in damage to the machine.

**DO NOT** obstruct air intake and discharge openings. A minimum of 3 in. (76 mm) of air clearance on both sides of the machine is required. It is recommended to place the rear of the machine against the wall to prevent the recirculation of warm air. Failure to follow this instruction may cause poor machine performance and damage to the machine.

**For Indoor Use Only:** This machine is designed to operate indoors, under normal ambient temperatures of 70°F to 75°F (21°C to 24°C). The machine has successfully performed in high ambient temperatures of up to 104°F (40°C) at reduced capacities.

**Noise Level:** Airborne noise emission does not exceed 78 dB(A) when measured at a distance of 39 in. (1.0 m) from the surface of the machine and at a height of 62 in. (1.6 m) from the floor.



**CAUTION!** This machine is pressurized when in operation. The control switch must be in the OFF position until the machine is completely assembled. No part should ever be removed from the machine while it is in operation. No part should be removed until the control switch has been turned to the OFF position and all pressure has been relieved by opening the draw valve.

Failure to follow these instructions may result in severe personal injury from hazardous moving parts or from the impact of propelled parts.



**WARNING!** Only install this machine in a location where its use and maintenance is restricted to trained personnel. Failure to comply may result in personal injury.



**WARNING! Asphyxiation Hazard!**  
If used with CO<sub>2</sub> (Carbon Dioxide) or N<sub>2</sub> (Nitrogen), always make sure the area is well ventilated. Vent exhaust gas to outside atmosphere using a hose. Failure to do so can cause serious injury.



## Model 345

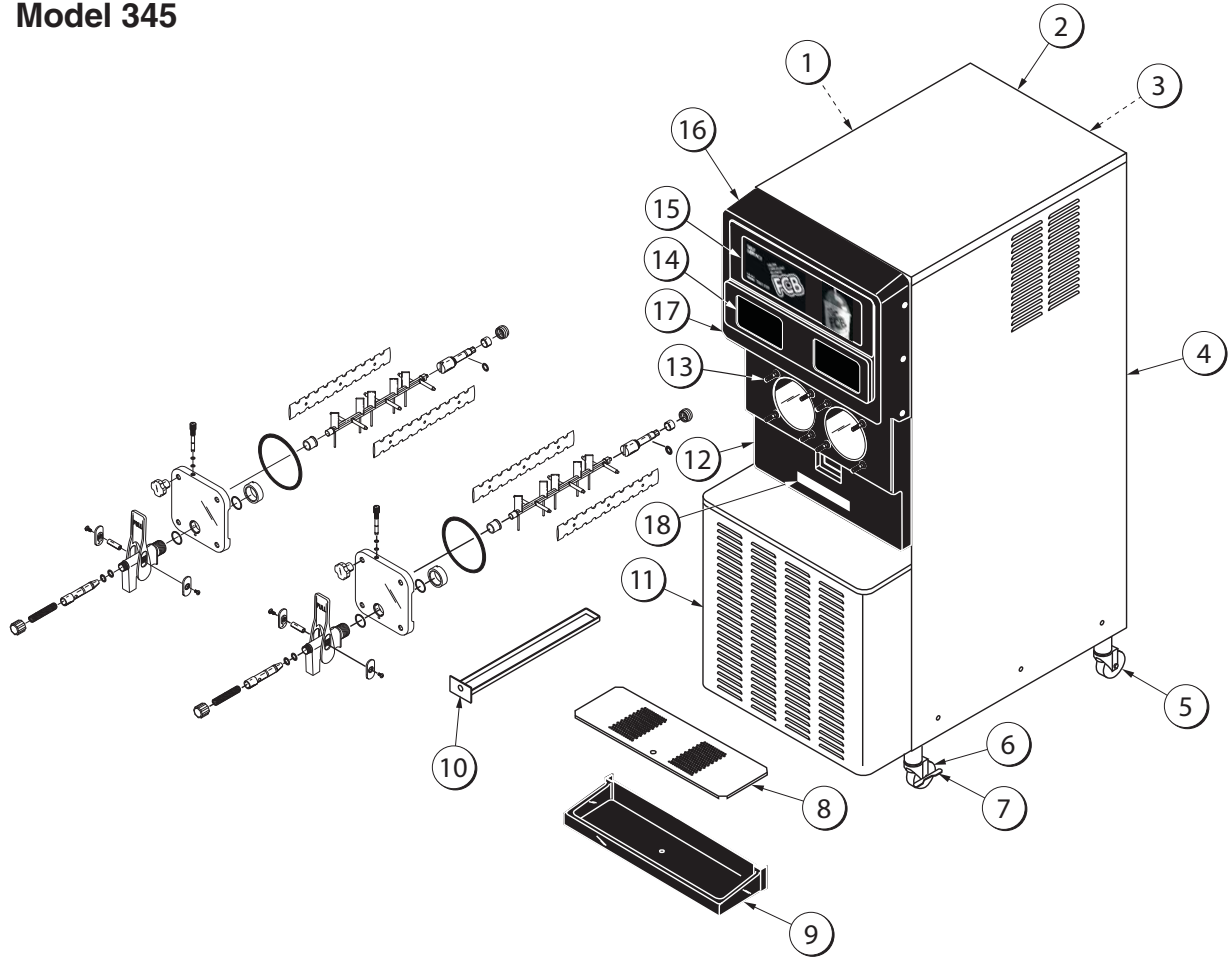

4

Figure 4-1

Item	Description	Part No.
1	Panel A.-Side Left	X45136
2	Hood	044618
3	Panel-Rear	<a href="#">044921-SP1</a>
4	Panel A.-Side Right	X44919
5	Caster-3" SWV 3/4-10 Stem	021279
6	Caster-3" SWV w/Brake	030307
7	Lock-Caster BRKT	032571
8	Shield-Splash	043719
9	Tray-Drip Black w/Drain	<a href="#">043720-SP</a>
10	Pan-Drip 19-1/2 Long	035034
11	Panel-Service	044916

Item	Description	Part No.
12	Panel-Front-Lower	<a href="#">043599-BLA</a>
13	Stud-Nose Cone 5/16-18	020445
*13a	Washer-Freezer Stud	036265
14	Card-Flavor Packet	035324
15	Card-FCB POP	043957
16	Panel-Front-Upper	<a href="#">043600-BLA</a>
17	Plate-Dec-345-346-355* Black	<a href="#">043639-BLA</a>
18	Decal-Dec-Taylor Domed	053761
*19	Pan-Drip (White) for Drip Guide	043612

\*Not Shown

Model 346

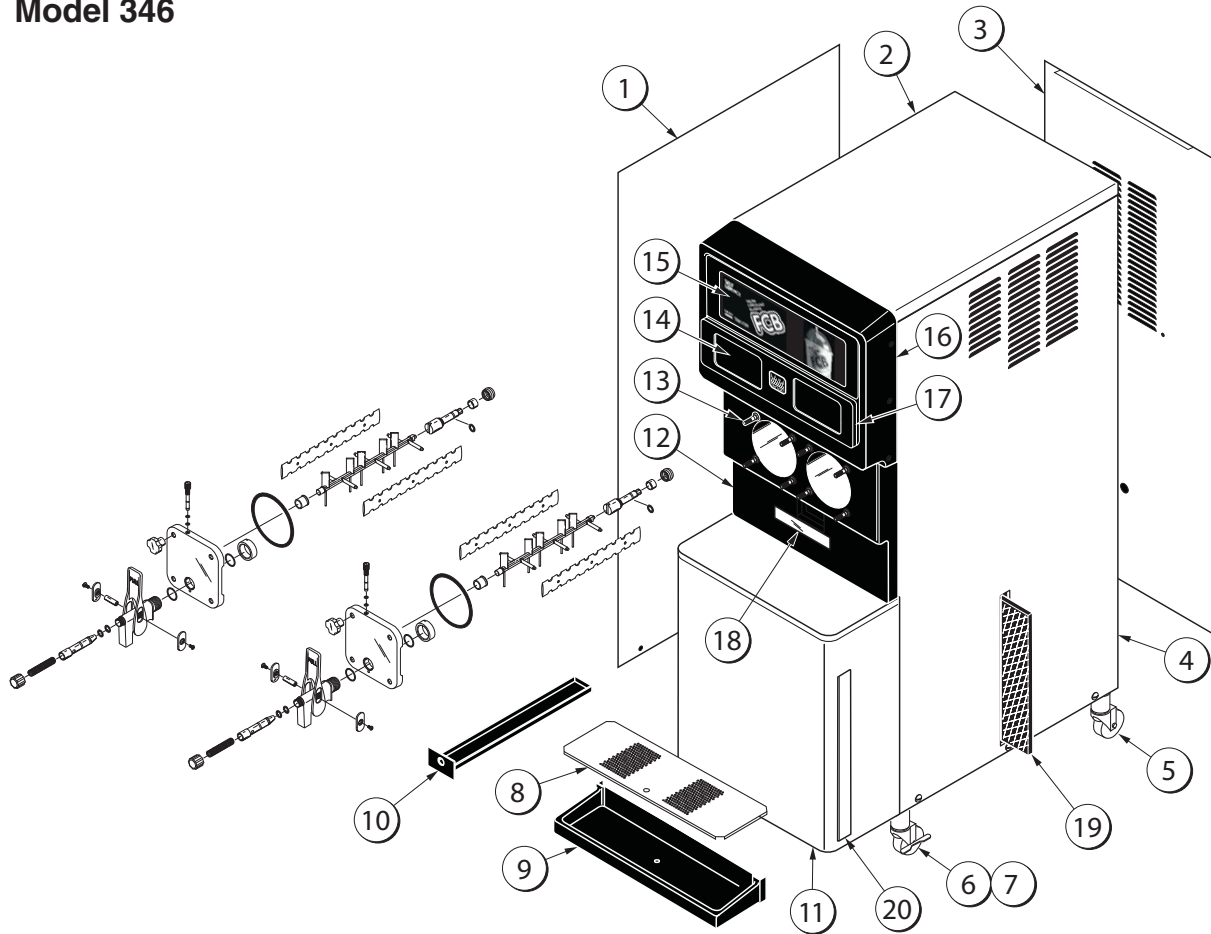

Figure 4-2

Item	Description	Part No.
1	Panel A.-Side Left	X44917
2	Hood	044618
3	Panel-Rear	044921-SP1
4	Panel A.-Side *346*AC*R*Filter	X53611
5	Caster-3" SWV 3/4-10 Stem	021279
6	Caster-3" SWV w/Brake	030307
7	Lock-Caster Bracket	032571
8	Shield-Splash	043719
9	Tray-Drip Black w/Drain	043720-SP
10	Pan-Drip 19-1/2 Long	035034
11	Panel-Service *346* Filter	053612

Item	Description	Part No.
12	Panel-Front-Lower	043599-BLA
13	Stud-Nose Cone 5/16-18	020445
*13a	Washer-Freezer Stud	036265
14	Card-Flavor Packet	035324
15	Card-FCB POP	043957
16	Panel-Front-Upper	043600-BLA
17	Plate-Dec-345-346-355* Black	043639-BLA
18	Decal-Dec-Taylor Domed	053761
19	Filter- Air 18L x 16.5H x .70W AC	052779-1
20	Cover-Hole-Filter -Snap In	053801
*21	Pan-Drip (White) for Drip Guide	043612

\*Not Shown

Model 349

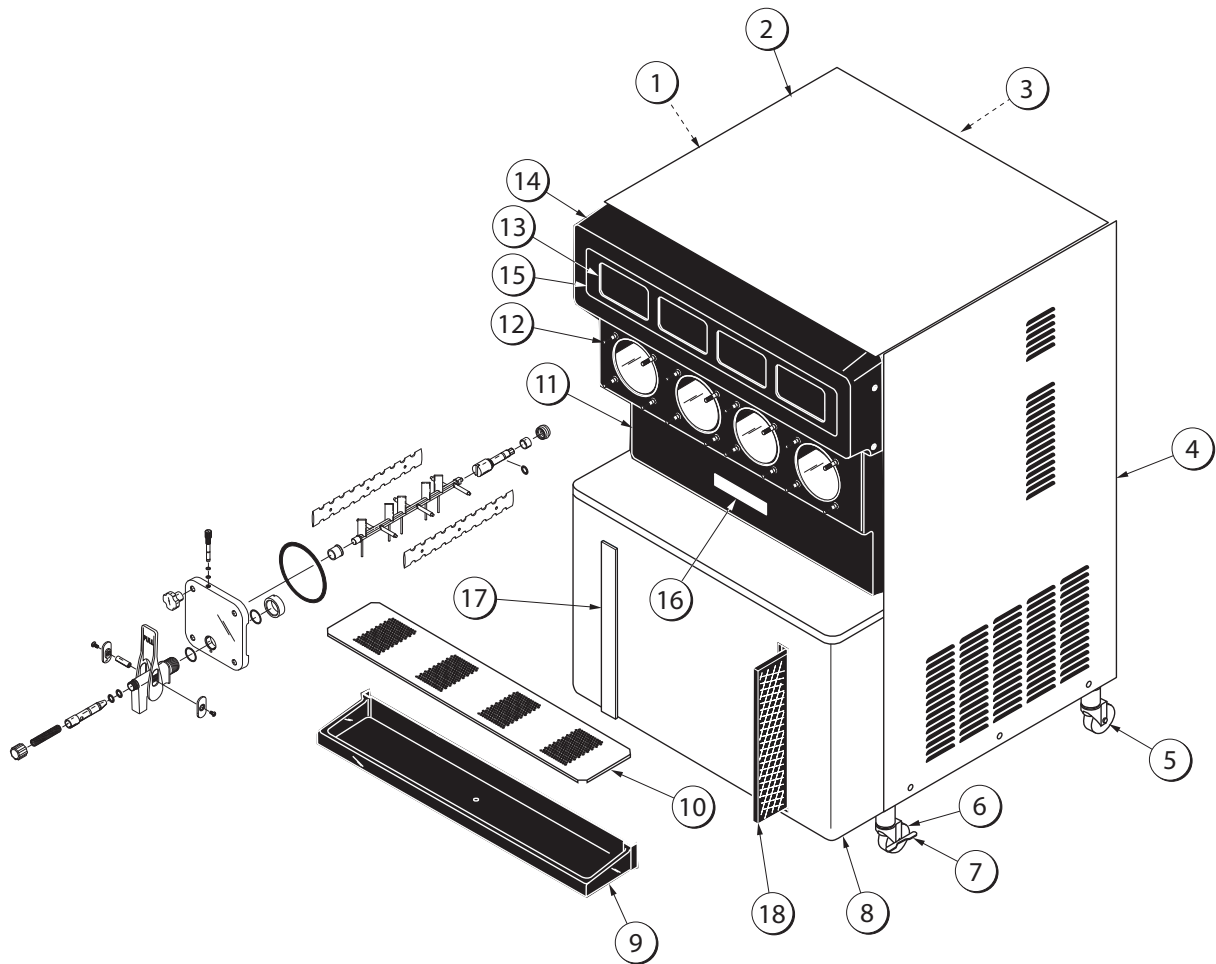

4

Figure 4-3

Item	Description	Part No.
1	Panel A.-Side Left	X42289
2	Hood	042166
3	Panel-Rear *349* Drain Hole	042198
4	Panel A.-Side Right	X42291
5	Caster-3" SWV 3/4-10 Stem	021279
6	Caster-3" SWV w/Brake	030307
7	Lock-Caster BRKT	032571
8	Panel-Service	053652
9	Tray-Drip Black w/Drain	<a href="#">038275-SP</a>
10	Shield-Splash	038276
11	Panel-Front-Lower *BLK	<a href="#">042082-BLA</a>

Item	Description	Part No.
12	Stud-Nose Cone	020445
*12a	Washer-Freezer Stud	036265
13	Card-Flavor Packet	035324
14	Panel-Front-Upper *BLK	<a href="#">042081-BLA</a>
15	Plate-DEC *Black	<a href="#">035410-BLA</a>
16	Decal-DEC-Taylor Domed	053761
17	Cover-Hole-Filter- Snap In	053801
18	Filter- Air 18 L x 16.5 H x .7 W	<a href="#">052779-1</a>
*19	Pan A.-Drip *w/Hose-Left	<a href="#">X42201</a>
*20	Pan A.-Drip *w/Hose-Right	<a href="#">X42203</a>

\*Not Shown

Model 355

4

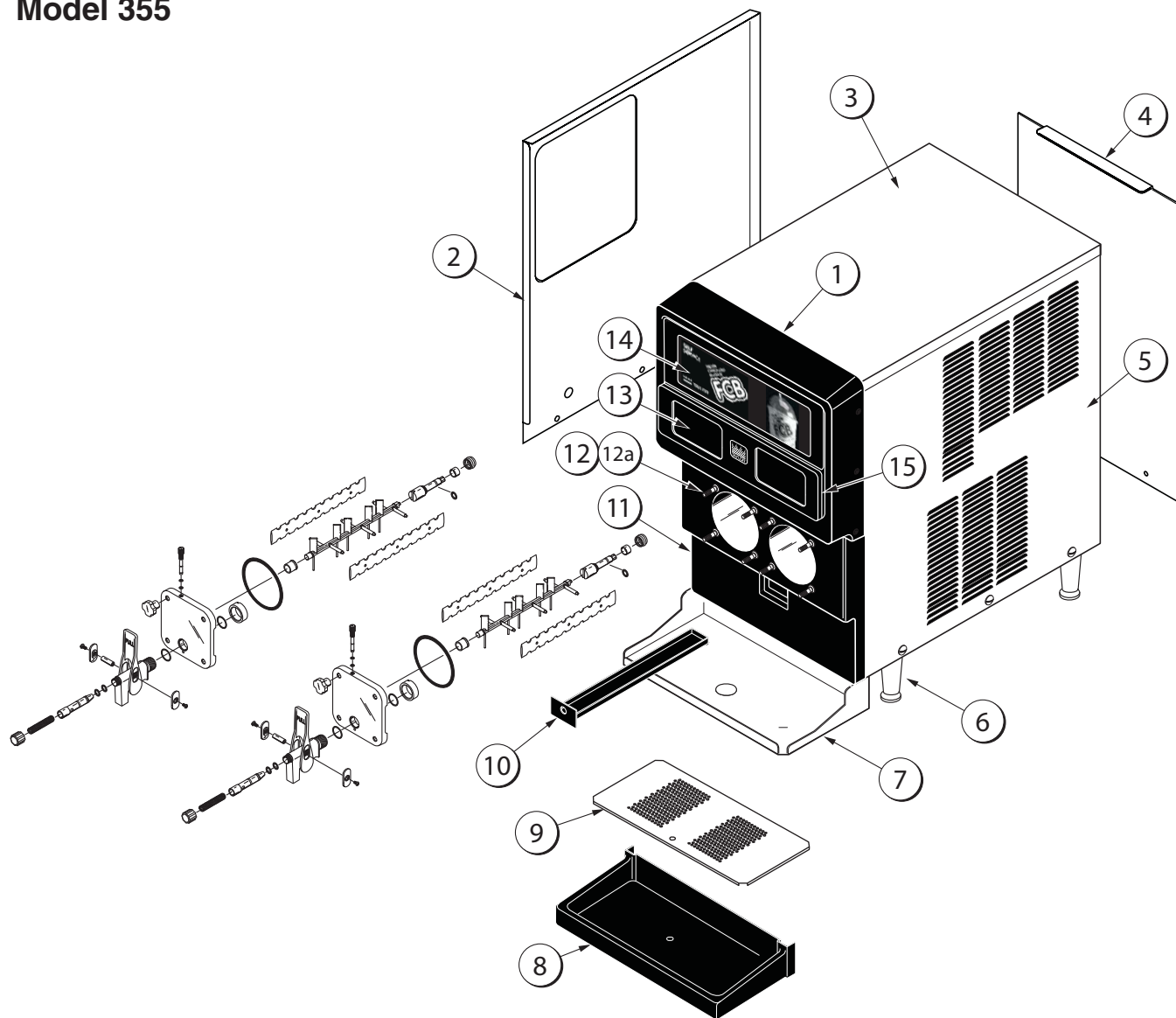

Item	Description	Part No.
1	Panel-Front-Upper *BLA	043600-BLA
2	Panel-Side *Left*	044619-SP
3	Hood	044618
4	Panel-Rear *Stainless	044621-SS
5	Panel-Side *Right	044620-SP
6	Leg-4" 3/8- 6 Stud	036397
7	Shelf-Drip Tray	049697
8	Tray-Drip*Black w/o Drain	043720
9	Shield-Splash	043719

Item	Description	Part No.
10	Pan-Drip 19-1/2 Long	035034
11	Panel-Front-Lower*Black	043599-BLA
12	Stud-Nose Cone 5/16-18	020445
12a	Washer-Freezer Stud	036265
13	Card-Flavor Packet	035324
14	Card-FCB POP	043957
15	Plate-Dec-345-346-355* Black	043639-BLA
*16	Pan-Drip (White) for Drip Guide	043612

\*Not Shown

Door Assembly

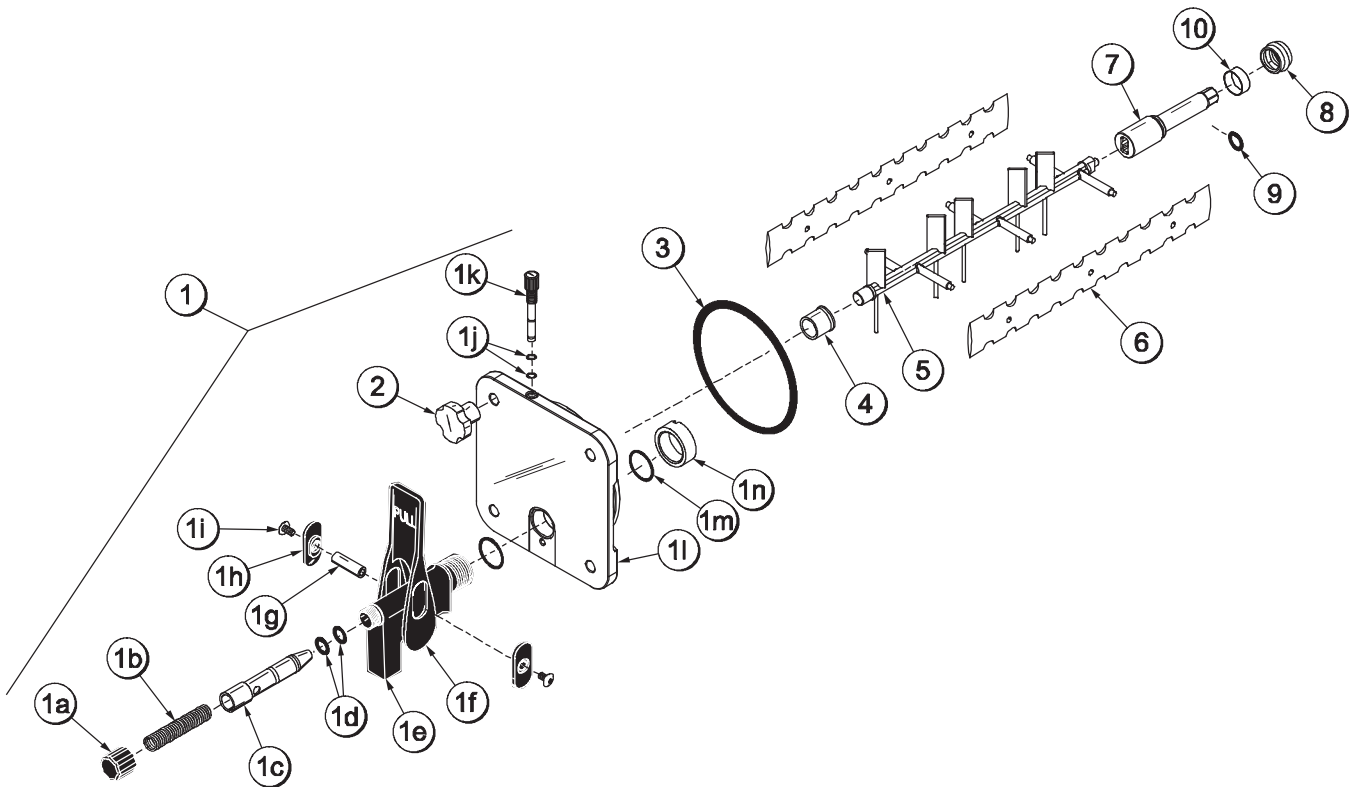

4

Figure 4-4

Item	Description	Part No.
1	Door	
1a	Cap-Spout-Door-FCB-BLK	046191-BLA
1b	Spring-COMP.480X.072X3.0	039320
1c	Valve-Draw-Door-Press	039324
1d	O-ring-9/16 OD X .103W	016369
1e	Spout-Door-FCB-Black	046190-BLA
1f	Handle-Draw-FCB-Black	046192-BLA
1g	Pin-Pivot-Spout-Door	039321
1h	Slide-Handle-Door-BLK	046193-BLA
1i	Screw-10-32X3/8PHL-TRUS	053869
1j	O-ring-9/32 OD X 1/16 Wall	029751
1k	Plug-Prime-Slush-Press	039568
1l	Door A.-Freezer-Slush	X80599

Item	Description	Part No.
1m	O-ring-1.129 ODX.989ID	039219
1n	Nut-Spout-Door-Press	039323
2	Nut-Stud	043666
3	O-ring-5-1/4ODX.210W (Door)	017003
4	Bearing-Front-Pressure	039349
5	Beater-Plastic-FCB-Press.	041182
6	Blade-Scraper-FCB-16inch	041103
7	Shaft-Beater-Slush-PRES	083418
8	Seal-Drive Shaft	032560
*9	O-ring-7/8 OD X .139W (Beater Shaft)	025307
10	Bushing-Beater Shaft/Boot Seal	042278

**\*Note:** O-ring 025307 is not used on all models. However, units built prior to 10/2009 that have not been updated with metal rear shell bearing X67222 or X83989 still require O-ring.

Accessories

4

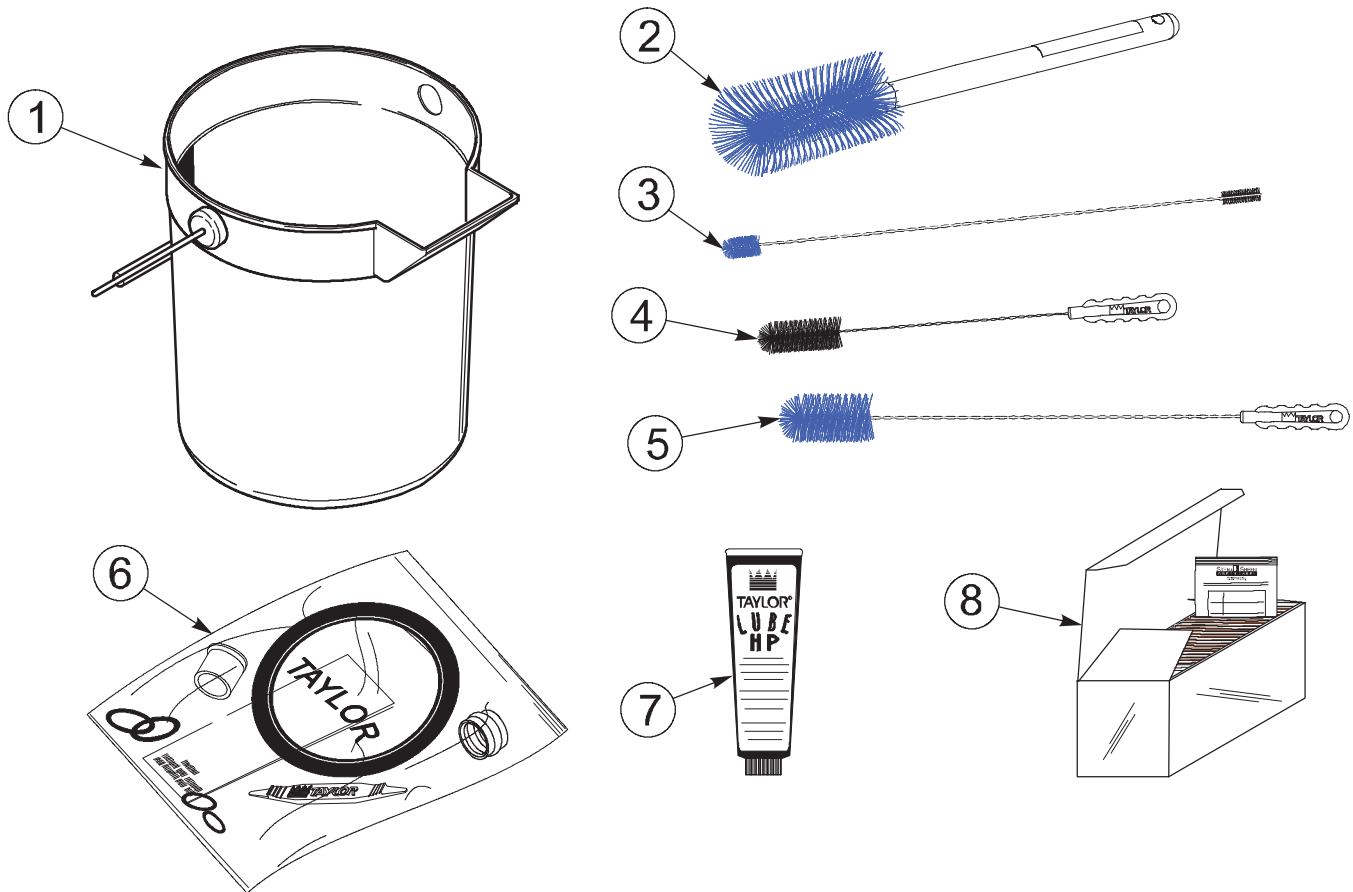
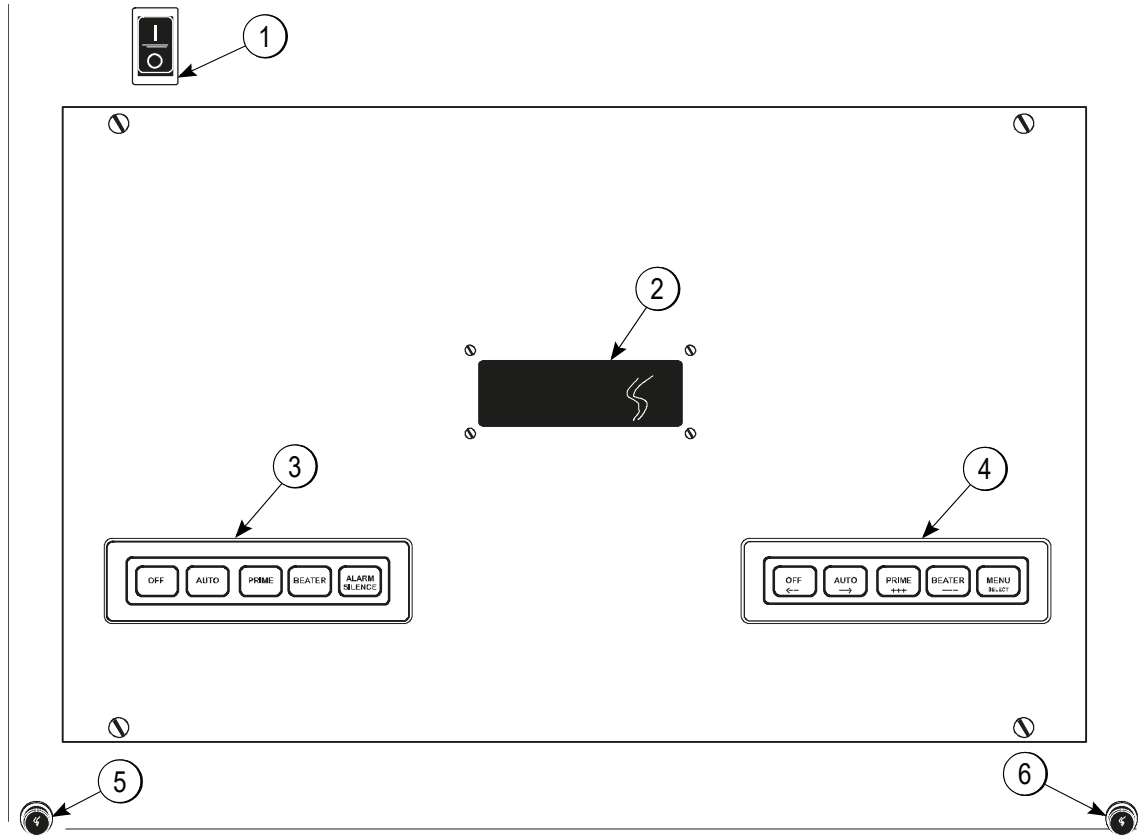

Figure 4-5

Item	Description	Part No.
1	Pail-10 qt.	013163
2	Brush-Mix Pump Body-3"X7"	023316
3	Brush-Double Ended	013072
4	Brush-Rear BRG 1"DX2"L	013071

Item	Description	Part No.
5	Brush-Draw Valve 1-1/2"OD	014753
6	Kit A.-Tune Up	<a href="#">X39699</a>
7	Lubricant-Taylor Hi Perf	048232
8	Sanitizer-Stera-Sheen®	*See Note

**\*Note:** A sample container of sanitizer is sent with the machine. For reorders, order Stera-Sheen® part no. 055492 (100-2 oz. packs) or Kay-5® part no. 041082 (200 packs).



5

Figure 5-1

Item	Description
1	Control Switch
2	Liquid Crystal Display (LCD)
3	Keypad-Left







Item	Description
4	Keypad-Right
5	Product Light-Left Side
6	Product Light-Right Side

## Symbol Definitions (Model 349 Only)

To better communicate in the international arena, the words on many of our operator switches and keys have symbols to indicate their functions. Model 349 is designed with these international symbols.

The following table identifies the symbol definitions used on Model 349.

Table 5-1

	= ON
	= OFF
	= AUTO
	= PRIME
	= BEATER MOTOR
	= ALARM SILENCE
	= MENU/SELECT

## Control Switch

The control switch is located on top of the control box on Models 345, 346, and 355. It is located on the rear of the control box on Model 349. When placed in the ON position allows for Slushtech™ operation.

## Liquid Crystal Display

The liquid crystal display (LCD) is located on the front control panel. The LCD is used to show the current operating mode of the freezing cylinders. The LCD also indicates whether there is enough syrup, CO<sub>2</sub>, and water being supplied to the freezer. If an error in the machine operation occurs, a warning tone will sound and the word FAULT will flash on the third line of the display.

## Operational Mode Display

When the machine is plugged into the wall receptacle and the power switch is placed in the ON position, the following screen appears.

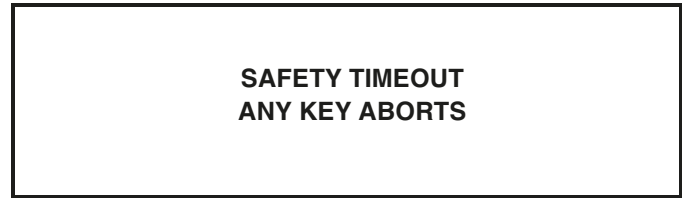

This display will remain on the LCD for 60 seconds unless a key is pressed. If any key is pressed (or 60 seconds pass), the following screen appears:

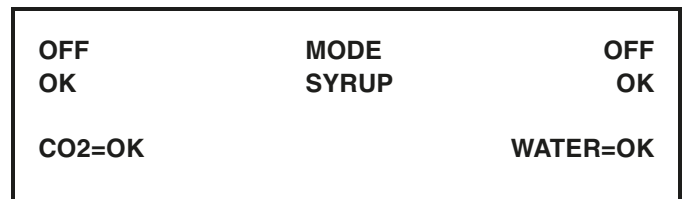

*Note: Syrup, CO<sub>2</sub>, and water are satisfied.*

Pressing both AUTO keys will display the following screen.

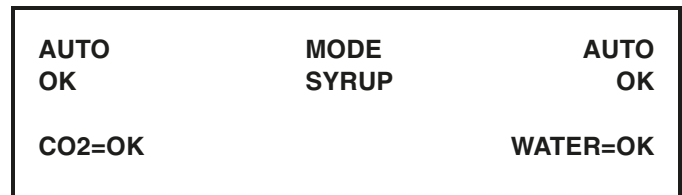

Line 1 indicates the operating mode for each cylinder.

Line 2 indicates the status of the syrup systems in each freezing cylinder.

Line 3 indicates if there is a fault in the system (left side).

The same rules apply to the fourth line, which indicates the status of the CO<sub>2</sub> and the H<sub>2</sub>O.

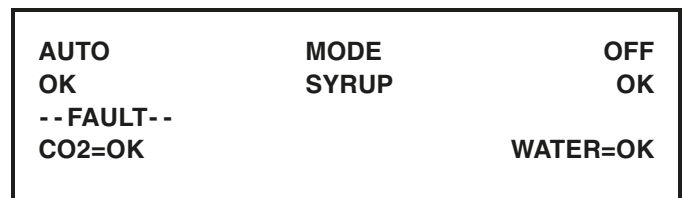

## Operator Menu Display

The OPERATOR MENU is used to enter the operating screens. To access the OPERATOR MENU, press the word MENU. The cursor will flash under the letter A, indicating that this is screen A. To select a different screen, use the arrow keys to move the cursor to the desired screen selection and press the SELECT key.



## Operator Menu Timeout

If the display is left in the operator menu or any of the operator menu selections, except for current conditions, the display will return to the system mode screen 60 seconds after the last key press. The current conditions screen will be displayed until manually changed.

## Finding Current Fault Conditions

Screen B is FAULT DESCRIPTION. The FAULT DESCRIPTION will indicate if there is a fault in one of the freezing cylinders. When the fault is corrected, the warning tone will stop. Only the last two fault messages require pressing the OFF/<- - - key to clear the fault message and warning tone.

Table 5-2

Fault Messages	
No Fault Found	No fault conditions are apparent.
Beater Overload	Beater is out on overload.
Chk Refrig Sys Psi	Compressor is out on high head pressure (or low suction pressure = option that applies to some units)
Thermistor Short	Shorted thermistor probe.
Thermistor Open	Open thermistor probe.
H <sub>2</sub> O Pressure Low	Water pressure is low.
CO <sub>2</sub> Pressure Low	CO <sub>2</sub> pressure is low.
Syrup Pressure Low	Syrup is no longer present.
BRL Temp 2 High	Freezing cylinder temperature is above 120°F (49°C).
BRL Not Cooling	Freezing cylinder is not cooling after 5 minutes.

The following are explanations of the possible faults and the display screens.

The second and third lines indicate the faults found in the left and right freezing cylinders respectively. The following screen indicates that no faults exist on either side. To see if there is more than one fault, press the +++ key.

1. **NO FAULT FOUND**—No fault conditions are apparent.



**Note:** On Model 349, faults for freezing cylinders one and two are shown on the first screen. Press the SELECT key to read fault messages for freezing cylinders three and four.

2. **BEATER OVERLOAD**—The beater motor is out on overload. When this fault occurs, the machine automatically turns off. The fault clears when the condition is corrected.

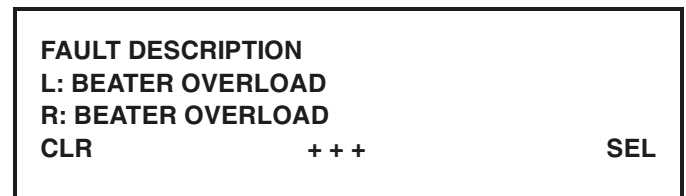

3. **CHK REFRIG SYS PSI**—The compressor is out on high head pressure (or low suction pressure, an option that applies to some machines). When this fault occurs, it places the machine in the Off mode. The fault clears when the condition is corrected.

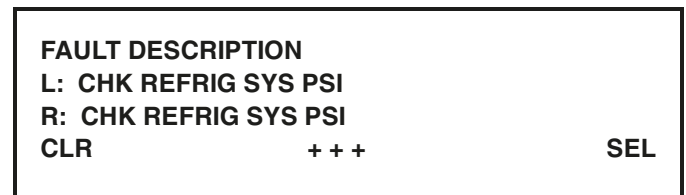

4. **THERMISTOR SHORT**—One or both of the barrel (freezing cylinder) thermistor probes are faulty.

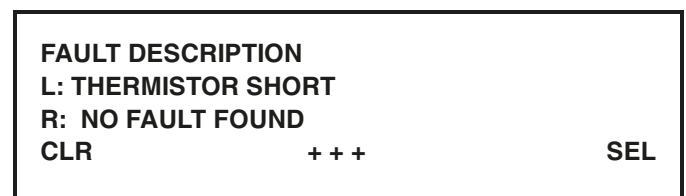



## Setting the Clock

Screen C is SET CLOCK. Move the cursor under the number you wish to change. Press the +++ key to increase the number; press the --- key to decrease the number. When the desired time and date appear, press the SELECT key once to return to the OPERATOR MENU.

**Note:** The clock is programmed in military time.

SET CLOCK		
<u>14:30</u>		6/25/03
< - - - - >	+++	- - -
SEL		

The following screen will appear if an invalid date is entered (example: if the date entered exceeds the days of that month):

SET CLOCK		
<u>14:30</u>		02/31/04
	INVALID DATE	
		SEL

The following screen allows the DAYLIGHT SAVING TIME options.

DAYLIGHT SAVING TIME		
<u>ENABLE</u>	DISABLE	
< - - - - >		SEL

If the DAYLIGHT SAVING TIME option is enabled, then the time will be advanced by 1 hour at 2:00 a.m. on the first Sunday in April, and will be retarded by 1 hour at 2:00 a.m. on the last Sunday in October.

## Manual Defrosting

Screen D is MANUAL DEFROST. This screen allows the operator to manually defrost the left side of the machine.

1. Place the cursor under YES, and press the SELECT key, and the command will be executed.

MANUAL DEFROST		
LEFT SIDE	<u>YES</u>	NO
< - - - - >		SEL

2. Repeat step 1 for the right side of the machine.

MANUAL DEFROST		
RIGHT SIDE		<u>YES</u> NO
< - - - - >		SEL

**Note:** Models 345 and 355 allow only one freezing cylinder to be defrosted at a time. This applies to freezing cylinder pairs on the model 349. Attempting to place a freezing cylinder into defrost while the other freezing cylinder is defrosting will result in the following screen. (Model 346 does not have this restriction.)

ALREADY IN DEFROST	
--------------------	--

Press the SELECT key to return the machine to the operator menu.

## Current System Information

Screen E is SYSTEM INFORMATION. It consists of six display features.

Press the SELECT key to advance to the next feature.

- The first feature indicates the software version.

SYSTEM INFORMATION		
355 CONTROL UVC2		
VERSION 2.00		
		SEL

- The second feature indicates the Bill Of Materials (B.O.M.) number and the serial number. It also indicates if the machine is equipped with a water pressure switch.

B.O.M. 035527C000		
S/N K0000000		
WITH H2O PRESS SW		
		SEL

## USER INTERFACE

- The third feature indicates the version number of the LANGUAGE and text.

```

SYSTEM INFORMATION
LANGUAGE
VERSION 1.05      ENGLISH 386
SEL
    
```

- The fourth feature will display the POWER SAVER MODE, as OFF, REST, or STANDBY. If the POWER SAVER MODE is OFF, the following screen will be displayed:

```

POWER SAVER MODE
OFF
SEL
    
```

- If a Power Saver mode is programmed, one of the following screens will appear. (Model 349 will display defrost information for freezing cylinders 1, 2, 3, and 4 instead of LEFT and RIGHT.)

There are seven possible Power Saver mode time frames (cycles). The second line shows the cycle (1 of 7) as well as the time and day at which the Power Saver mode will begin for that cycle. The third line shows the time and day that the Power Saver mode will end for that cycle. Press the +++ or --- keys to view other cycles.

```

POWER SAVER REST
CYCLE 1      SUN      01:00
              SUN      08:30
              +++      ---      SEL
    
```

```

POWER SAVER STANDBY
CYCLE 1      SUN      01:00
              SUN      08:30
              +++      ---      SEL
    
```

- The fifth feature will indicate the left side defrost time(s) and which day(s) the defrost will occur.

Each freezing cylinder has eight possible defrost times (cycles) for each day of the week. If all seven days have the same time for a given cycle, the following screen will appear. This example shows that all seven days have CYCLE 1 programmed for 9:00. Press the +++ or --- keys to view other cycles.

```

DEFROST TIME LEFT
CYCLE 1      ALL      09:00
              +++      ---      SEL
    
```

If one or more days of the week have a given cycle programmed at different times, the following display will appear. This example shows that Sunday's CYCLE 1 is programmed for 9:00. The fact that SUN is displayed (instead of ALL) indicates that for some other day(s) CYCLE 1 is programmed for a different time (or not programmed at all). Using the cursor keys, place the cursor under the cycle number. Press the +++ or --- keys to view other defrost times (cycles) for the day shown. Place the cursor under the day (SUN) and press the +++ or --- keys to access the other days of the week.

```

DEFROST TIME LEFT
CYCLE 1      SUN      09:00
<- - - - ->  +++      ---      SEL
    
```

- The sixth feature will indicate the right side defrost time(s) and the day(s) on which the defrost will occur.

**Note:** The functionality is the same as described previously for the left side defrost.

```

DEFROST TIME RIGHT
CYCLE 1      ALL      10:00
              +++      ---      SEL
    
```

```

DEFROST TIME RIGHT
CYCLE 1      SUN      10:00
<- - - - ->  +++      ---      SEL
    
```

Press the SELECT key to return to the OPERATOR MENU.

### Current Conditions

Screen F is CURRENT CONDITIONS. This screen displays the current viscosity and product temperature for each freezing cylinder. An asterisk (\*) will indicate which side is refrigerating. Press the SELECT key to return to the OPERATOR MENU.

**Note:** Viscosity is checked only when product temperature is below 40°F (4.4°C).

The following screen will display for Models 345, 346, and 355. Model 349 displays all four freezing cylinders.

<b>CURRENT CONDITIONS</b>		
L*	999HD	27.5F
R	1200HD	26.5F
		SEL

### Searching Fault History

Screen G is FAULT HISTORY. This option provides a record of the last 20 faults. The display also indicates the date and time at which each fault occurs.

<b>FAULT HISTORY</b>	<b>1</b>
06/25/03	08:34
<b>NO FAULT FOUND</b>	
+++ - - -	SEL

Press the arrow keys to increase or decrease the fault page.

Page numbers are located in the upper right corner of the display. The most recently recorded fault will appear on page 1.

<b>FAULT HISTORY</b>	<b>2</b>
06/25/03	
<b>R SYRUP PRESS LOW</b>	08:33
+++ - - -	SEL

The fault description is listed on the third line of the fault page.

<b>FAULT HISTORY</b>	<b>3</b>
06/25/03	08:32
<b>B H2O PRESS LOW</b>	
+++ - - -	SEL

Press the MENU/SELECT key to return to the OPERATOR MENU.

### Service Information

Screen H is SERVICE MENU. This screen allows the authorized service technician to access service information. Return to the OPERATOR MENU by using the arrow keys to move the cursor under the letter A, and press the MENU/SELECT key.

<b>OPERATOR MENU</b>	
A B C D E F G <u>H</u>	
<b>SERVICE MENU</b>	
< - - - - - >	SEL

### Syrup Out Indicator

<b>AUTO</b>	<b>MODE</b>	<b>AUTO</b>
<b>OUT</b>	<b>SYRUP</b>	<b>OK</b>
<b>CO2-OK</b>		<b>WATER-OK</b>

If the word OUT appears in one of the columns next to the word SYRUP, there is a lack of syrup or syrup pressure being supplied for the indicated freezing cylinder. If the machine is in the Auto or Prime modes, the product light will flash and a warning tone will sound for that freezing cylinder. At this time, replace the appropriate syrup. As a safety feature, the refrigeration system automatically stops to prevent a freeze-up in the freezing cylinder.

If a syrup-out condition occurs on one side, that side will enter the Hold mode, at which time refrigeration remains off, the beater continues to run, and the CO<sub>2</sub> solenoid is closed for that side to prevent the dispensing of product. The opposite side will not be affected.

### CO<sub>2</sub> Out Indicator

AUTO OK	MODE SYRUP	AUTO OK
CO <sub>2</sub> -OK		WATER-OUT

On the LCD, if the word OUT appears next to the word CO<sub>2</sub>, there is a lack of CO<sub>2</sub> being supplied to the freezer. The product light will also flash and a warning tone will sound. This will continue until the CO<sub>2</sub> is replaced. If the CO<sub>2</sub> is not replaced within 1 minute, the machine will shut down and a fault message will appear.

### Water Out Indicator

AUTO OK	MODE SYRUP	AUTO OK
CO <sub>2</sub> -OK		WATER-OUT

**5** On the LCD, if the word OUT appears next to the word WATER, there is a lack of water being supplied to the freezer. In addition, the product light will flash and a warning tone will sound. This will continue until the proper amount of water is supplied to the freezer. If the water is not supplied within 1 minute, the machine will shut down and a fault message will appear.

### Audio Alarm Silencer

The audio alarm will be disabled if the ALARM SILENCE key is pressed. If a new fault or fault condition occurs or the system mode changes, the audio alarm will be re-enabled automatically. If the audio alarm is silenced for more than 30 minutes without correcting the fault, it will be re-enabled automatically.

### Product Light

When the light is flashing, the product is not at serving viscosity. This will occur during the initial freeze down, a defrost cycle, a FAULT condition, power saver modes, or anytime the product temperature is above 32°F (0°C).

### Sampling Valve

The sampling valve is located behind the front drip tray. The sampling valve is used to obtain a brix reading.

### Daily Procedures

The following procedure should be performed daily.

1. Remove the splash shield, front drip tray, and center drip pan.
2. Take these parts to the sink and brush-clean them.
3. Reinstall the parts onto the freezer.

Models 345, 346, and 355 contain two 7 qt. (6.6 L) freezing cylinders. Model 349 contains four 7 qt. (6.6 L) freezing cylinders.



**CAUTION!** This machine is pressurized when in operation. The control switch must be in the OFF position until the machine is completely assembled. No part should ever be removed from the machine while it is in operation. No part should be removed until the control switch has been turned to the OFF position and all pressure has been relieved by opening the draw valve. Failure to follow these instructions may result in severe personal injury from hazardous moving parts or from the impact of propelled parts.

The control switch, located on the top side of the control box must be in the OFF position until the machine is completely assembled. No part should ever be removed from the machine while it is in operation. No parts should be removed until the control switch has been turned to the OFF position and all pressure has been relieved at the draw handle.

The syrup flow controls combine the two ingredients of soda water and syrup, and send this combination to the mix hoppers. As product is drawn, new product from the hopper will flow through a mix feed tube down into the freezing cylinder. The mix hopper is supplied with 20 lb. of CO<sub>2</sub> gas for dispensing the finished product.

We begin our instructions at the point where the parts are disassembled and laid out to air dry.

The following procedures will show you how to assemble the parts into the freezer, sanitize them, and prime the freezer with fresh product.

Duplicate the following procedures, where they apply, for the remaining freezing cylinder(s).

If you are disassembling the machine for the first time or need information to get to this starting point in our instructions, (See Disassembly on page 6-13.)

## Assembly



**WARNING!** Make sure the power switch is in the OFF position. Failure to follow this instruction may result in severe personal injury from hazardous moving parts.

**Note:** When lubricating parts, use an approved food grade lubricant (example: Taylor Lube HP).

1. Lubricate the O-ring groove. Slide the O-ring into the groove on the drive shaft. Lubricate the drive shaft seal groove, the O-ring, and the shaft portion that comes in contact with the bearing on the beater drive shaft. **Do not** lubricate the hex end of the drive shaft.

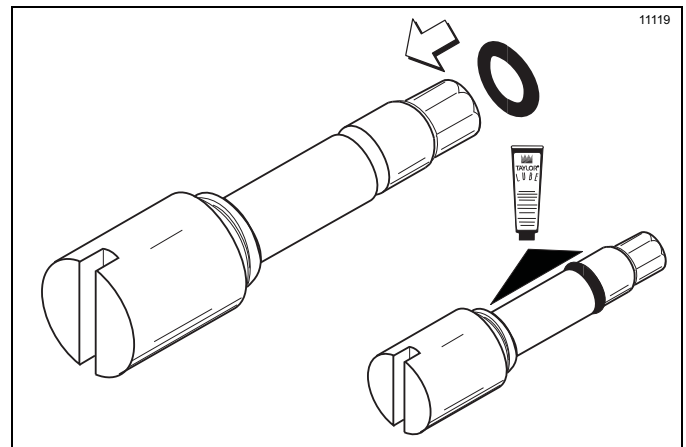

Figure 6-1

2. Lubricate the inside diameter of the drive shaft seal. Install the drive shaft seal bushing in the drive shaft seal.

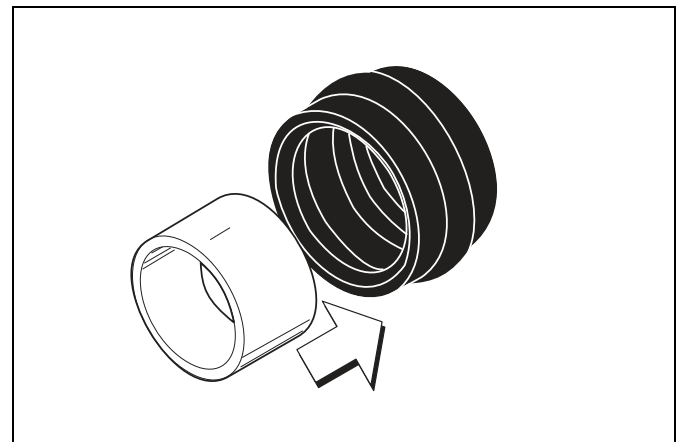

Figure 6-2

## OPERATING PROCEDURES

**Note:** The drive shaft bushing must be positioned in the center of the drive shaft seal.

- Slide the seal and bushing over the shaft and groove until it snaps into place. Fill the inside portion of the seal with 1/4 in. (6.35 mm) more lubricant and evenly lubricate the end of the seal that fits onto the rear shell bearing.

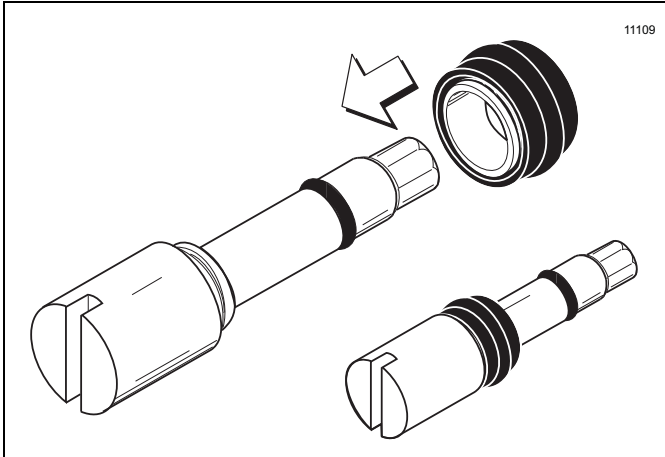

Figure 6-3

- Insert the drive shaft into the freezing cylinder (hex end first) and into the rear shell bearing, until the seal fits securely over the rear shell bearing. Make sure the drive shaft fits into the drive coupling without binding. Remove any excess lubricant from the seal.

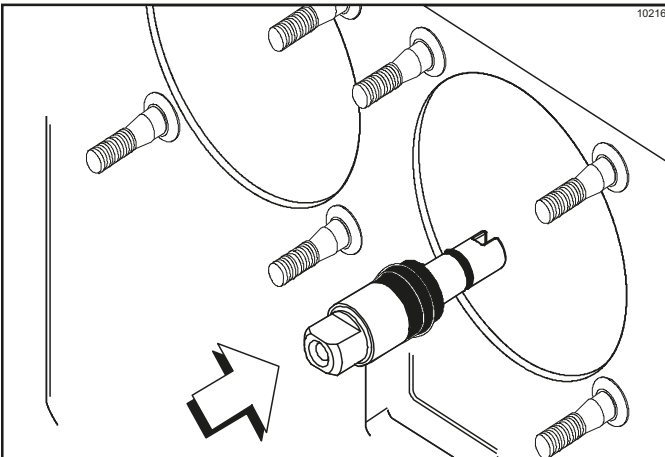

Figure 6-4



**WARNING!** This machine has many sharp edges that can cause severe injuries.

- DO NOT** put objects or fingers in the door spout. This may contaminate the product and cause severe personal injury from blade contact.
- USE EXTREME CAUTION** when removing the beater assembly. The scraper blades are very sharp.

- Install the beater assembly. First check the scraper blades for any nicks or signs of wear. If any nicks are present or if the blade is worn, replace both blades. If the blades are in good condition, place the scraper blades over the holding pins on the beater.

**Note:** Each hole on the scraper blade must fit securely over each pin.

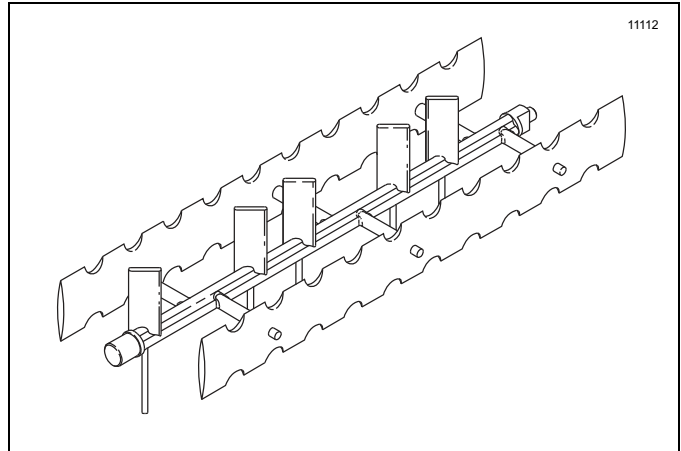

Figure 6-5

- Align the flats on the end of the beater assembly with the drive shaft. Make sure the beater assembly locating pin is in position in the locating hole of the drive shaft. Turn the beater slightly to make sure the beater is properly seated. When in position, the beater will be approximately 3/8 in. (9.52 mm) inside the front of the freezing cylinder.

**Important!** Failure to properly seat the beater may cause damage to the beater and the door.

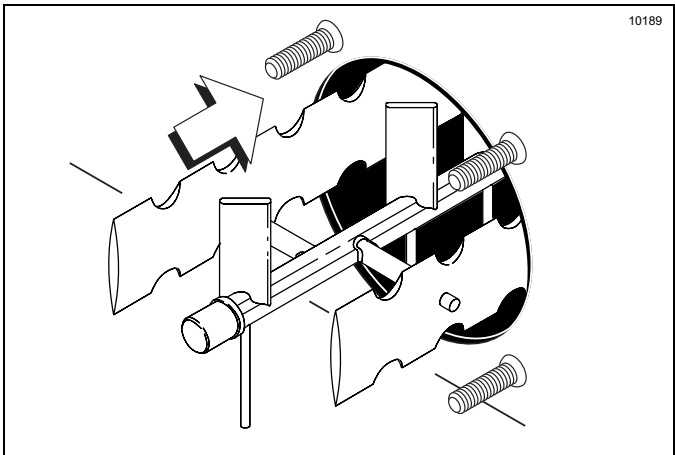

Figure 6-6

**Note:** The scraper blades on the beater assembly should be in the 6 o'clock and 12 o'clock positions. This will enable freezer door installation.

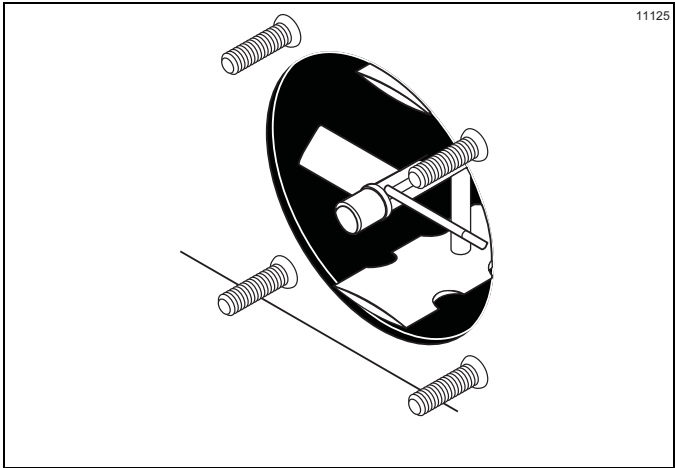

Figure 6-7

7. Install the draw valve. Slide the two O-rings into the grooves on the draw valve. Lubricate the O-rings and the valve as illustrated below.

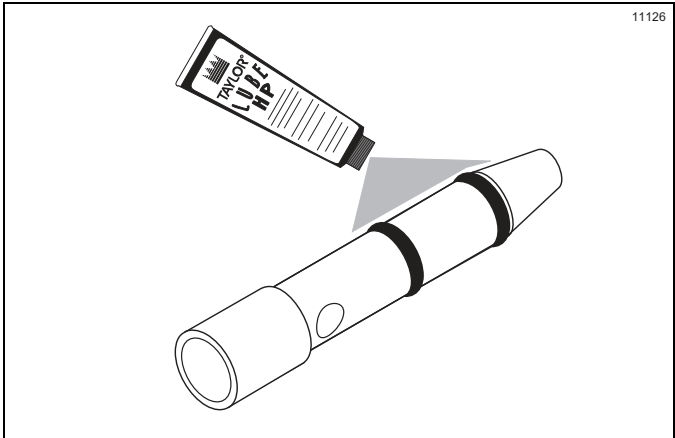

Figure 6-8

Insert the draw valve into the freezer door spout from

the front of the machine. The valve is properly installed when the hole in the draw valve is visible in the slot of the freezer door spout.

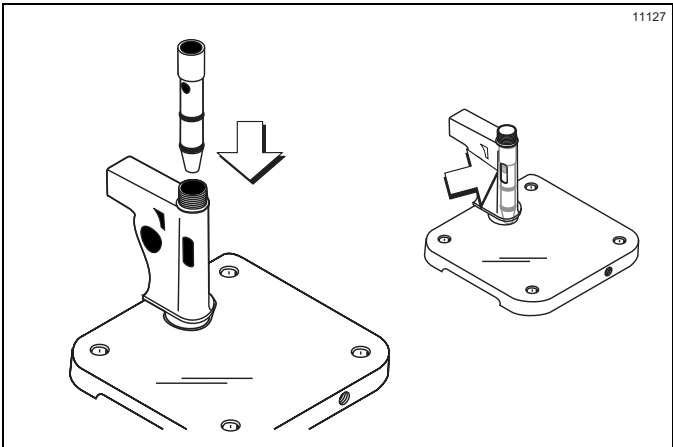

Figure 6-9

8. Snap the draw valve handle onto the door spout. Align the hole in the draw valve with the slot in the draw handle.

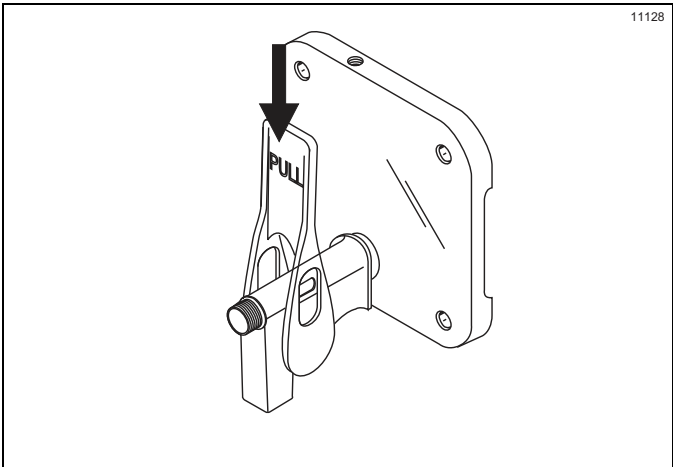

Figure 6-10

Slide the pivot pin through the draw handle and into the draw valve.

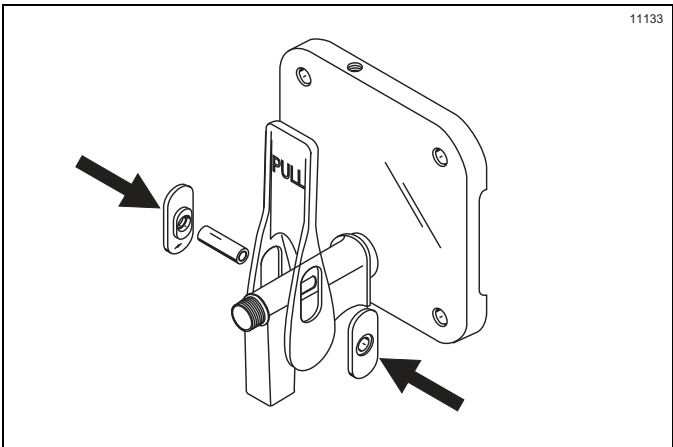

Figure 6-11

## OPERATING PROCEDURES

Place the draw handle slide over the opening in the draw handle and the pivot pin. Secure the assembly with screws.

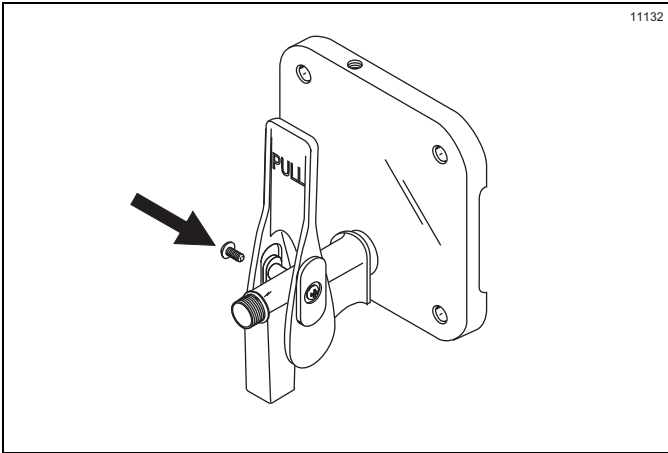

Figure 6-12

9. Insert the spring into the front of the door spout.

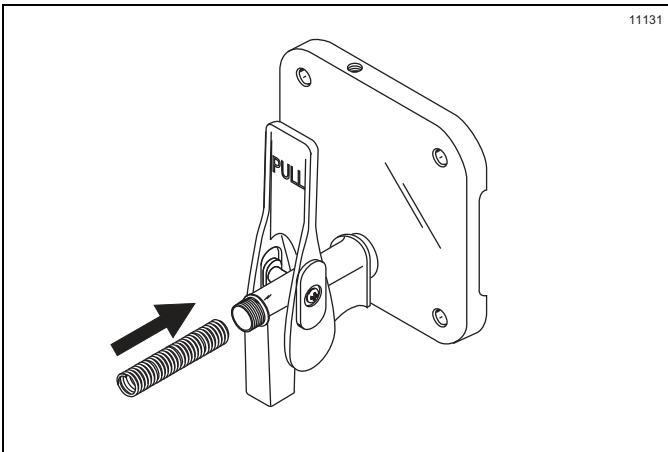

Figure 6-13

10. Place the threaded cap on the end of the draw valve cavity. Turn the cap clockwise until it is secure.

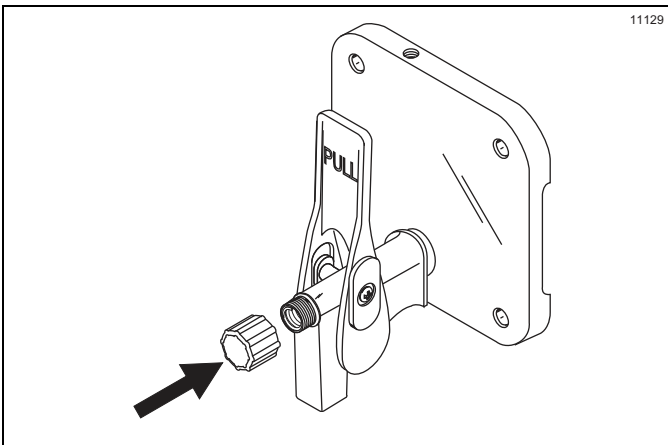

Figure 6-14

11. Install the prime plug. Place the two O-rings on the prime plug and lightly lubricate.

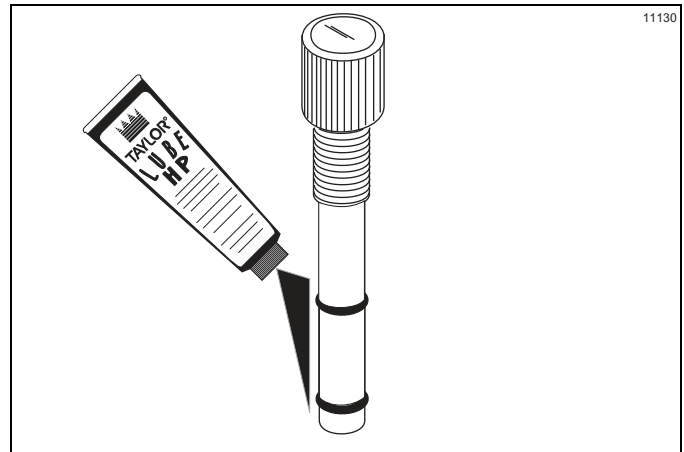

Figure 6-15

12. Place the large O-ring into the door groove and lightly lubricate.

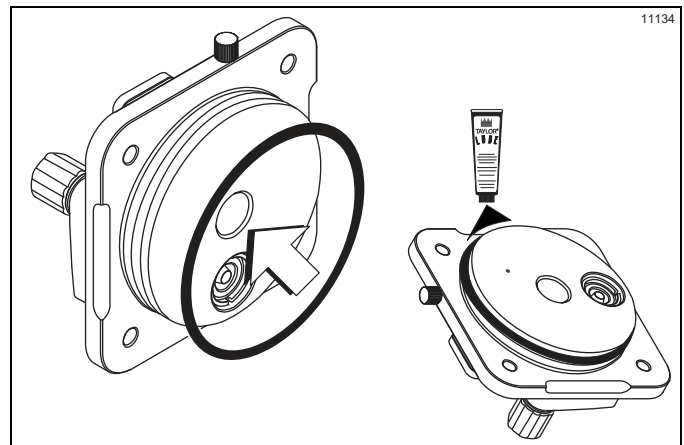

Figure 6-16

**Note:** Every three months, discard the O-rings and install new O-rings.

13. Install the front bearing. **Do not** lubricate the front bearing.

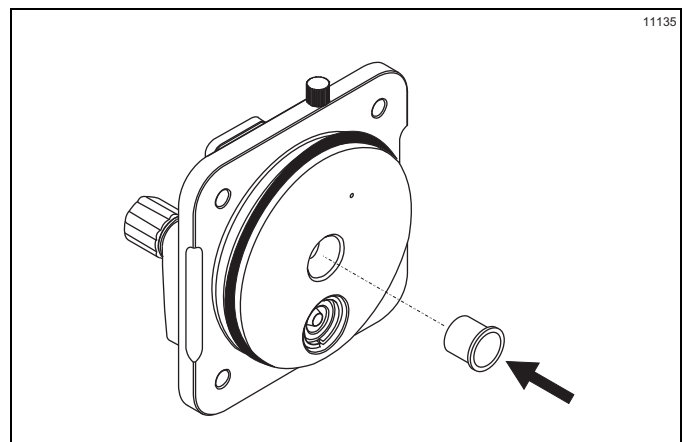

Figure 6-17

14. Install the freezer door. Position the door on the four studs on the front of the freezing cylinder. Firmly push the door into place. Install the four handscrews on the studs and finger-tighten them equally in a crisscross pattern to ensure that the door is secure. **Do not over-tighten the handscrews.**

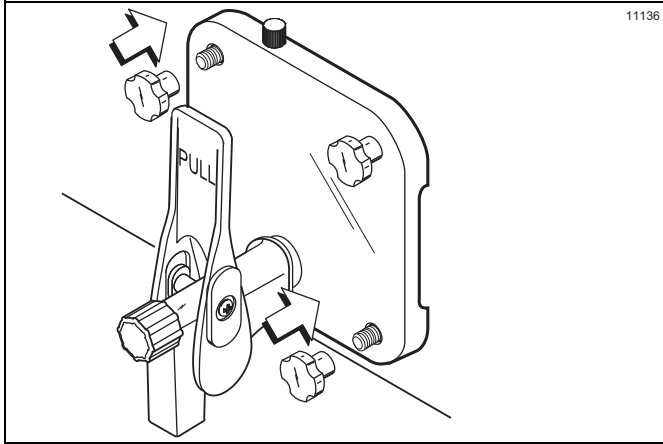

Figure 6-18

15. Place the O-ring into the groove of the hopper cover.

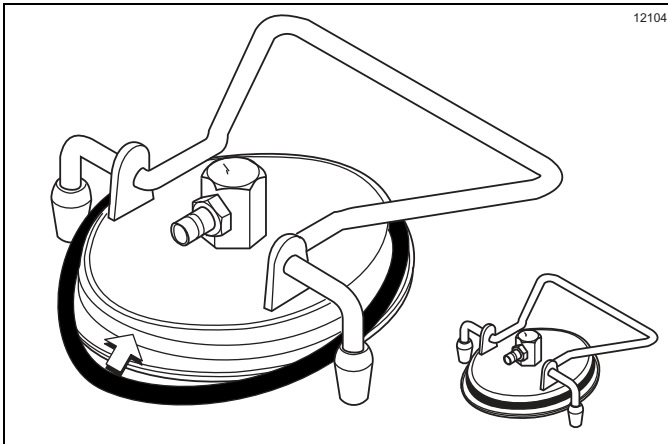

Figure 6-19

Install the hopper cover. Lock it into place.

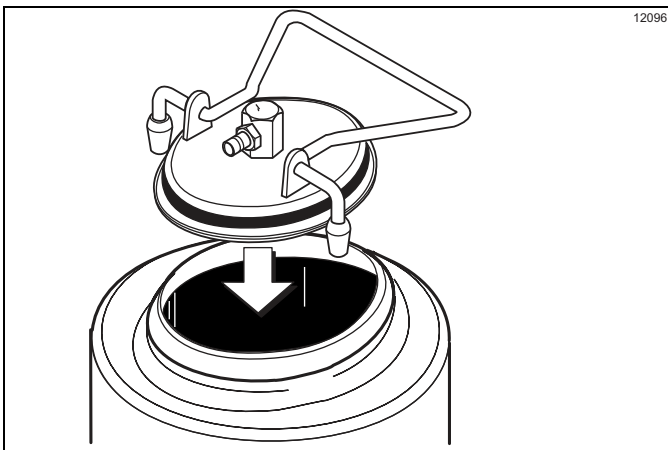

Figure 6-20

Attach the vinyl tube to the pressure relief on the hopper cover. Position the open end of the vinyl tube into the rear drip pan.

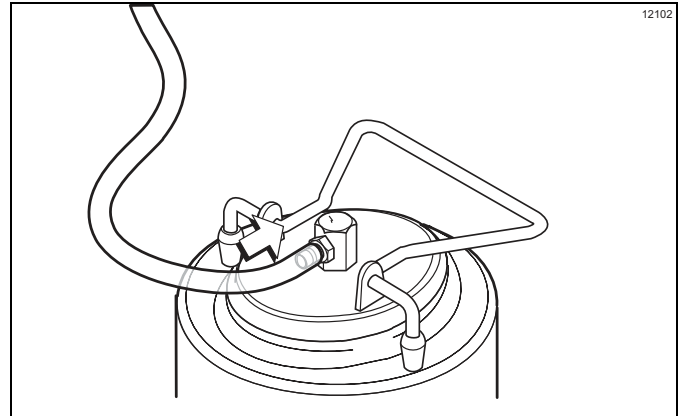
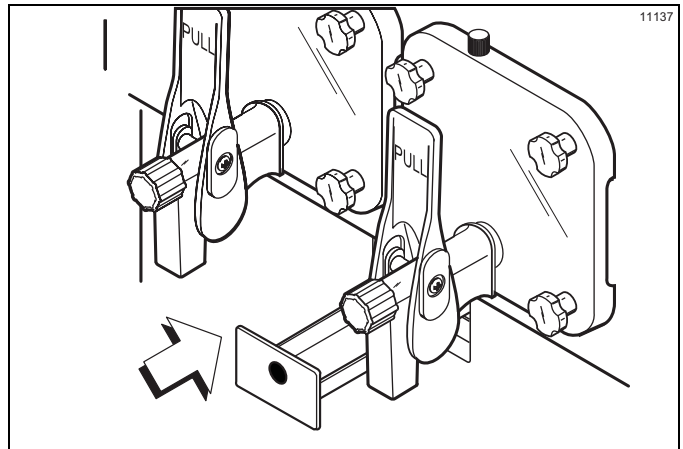

Figure 6-21

**Repeat Steps 1 through 15** for the remaining freezing cylinders.

16. Install the center drip pan through the front of the machine.



## Sanitizing

**Note:** If a machine is sanitized and will not be used for an extended period of time, clean water should be used to flush all sanitizer from the lines prior to storage of the machine. Upon return to service, the machine must be sanitized prior to use.

1. Open the lighted display door. Remove the hood and the side panels to gain access to the hoppers. Place the control switch in the ON position.

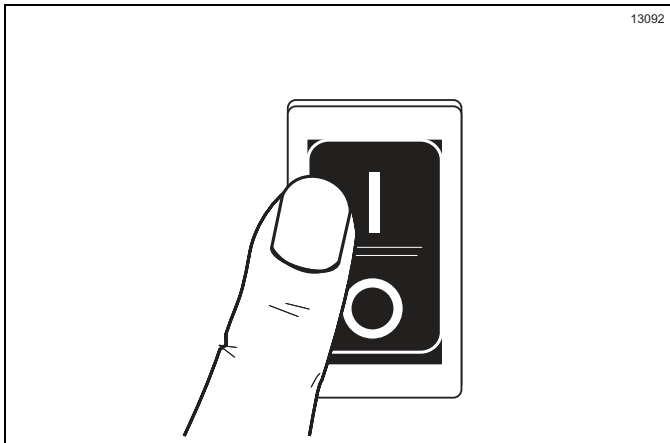

Figure 6-22

2. Prepare a pail of approved 100 PPM sanitizing solution (examples: 2-1/2 gal. [9.5 L] of Kay-5® or 2 gal. [7.6 L] of Stera-Sheen®). Use warm water and follow the manufacturer's specifications.

**Important!** Make sure the sanitizer is completely dissolved.

**For Bag-in-Box Units follow steps 3 through 5:**

3. Using an empty bag of syrup, cut the syrup line connection from the end of the bag.

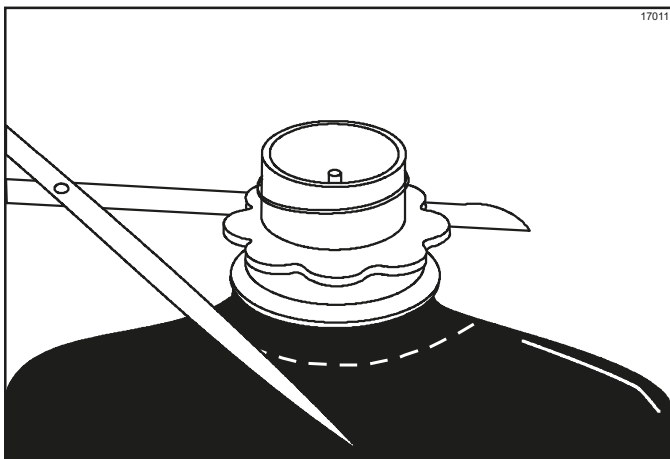

Figure 6-23

4. Connect the syrup line to the syrup connection that was cut from the syrup bag.

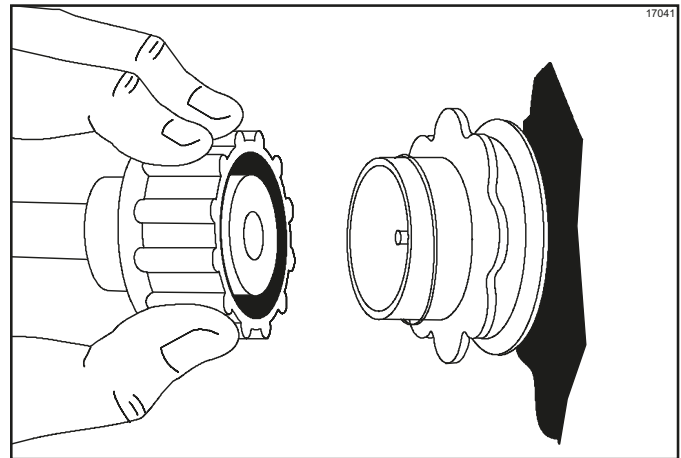

Figure 6-24

5. With the bag connector attached to the syrup line, place the syrup line into the pail of sanitizing solution.

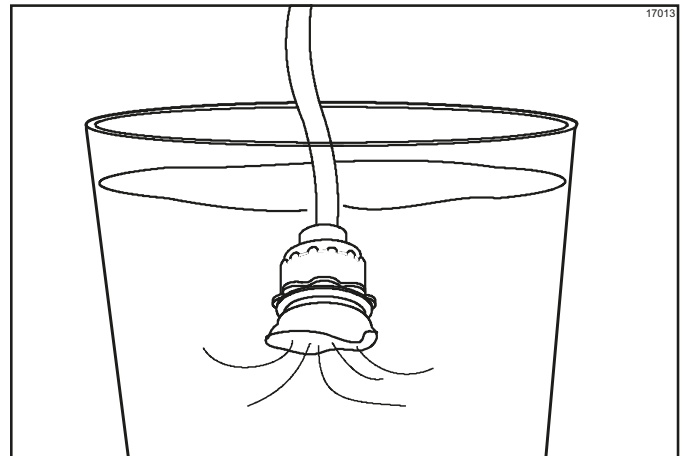

Figure 6-25

**For Syrup Tank Units follow step 6:**

6. Pour the solution into a clean, empty syrup tank. Place the syrup tank cover in position. Remove the CO<sub>2</sub> line and syrup line number one from the syrup tank for freezing cylinder number one. Connect these lines to the spare syrup tank filled with sanitizing solution.

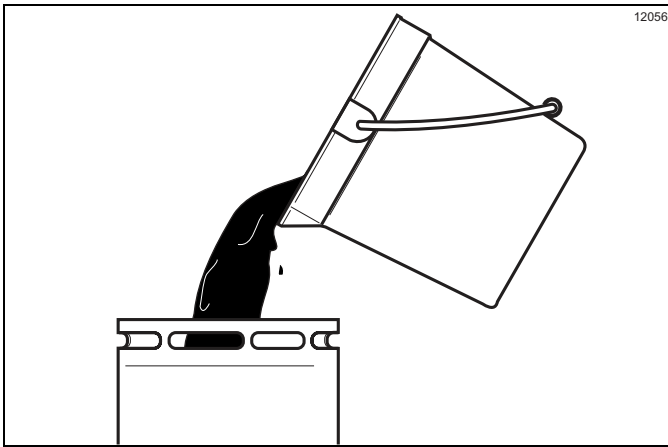

Figure 6-26

7. Press the PRIME key. This will cause the sanitizing solution to flow through the lines and into the mix hopper.

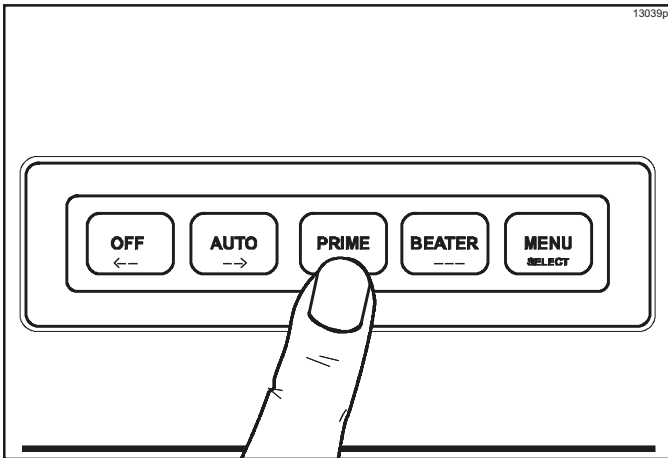

Figure 6-27

8. Place a pail beneath the sampling valve, which is located behind the front drip tray. Slowly open the sampling valve, and allow sanitizer to flow through this line and into the pail. After approximately 1/2 gal. (1.9 L) of sanitizer has been dispensed, close the valve.
9. Raise the prime plug only enough to allow a slight hissing sound. Place an empty pail under the door spout. When sanitizing solution begins to exit the relief port opening in the freezer door, lower the prime plug. Press the OFF key.

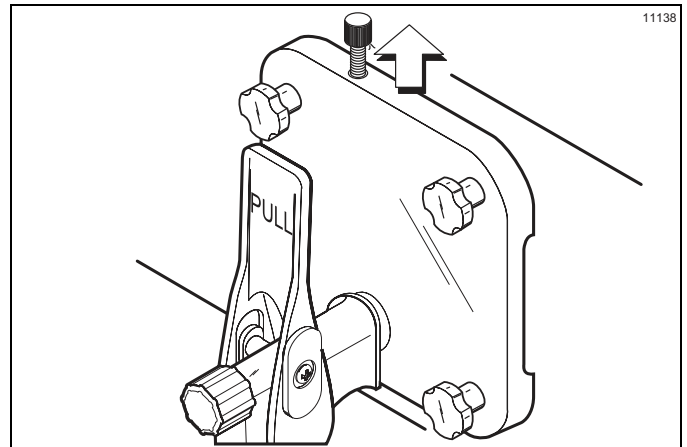

Figure 6-28

10. Prepare a pail of approved 100 PPM sanitizing solution (examples: 2-1/2 gal. [9.5 L] of Kay-5<sup>®</sup> or 2 gal. [7.6 L] of Stera-Sheen<sup>®</sup>). Use warm water and follow the manufacturer's specifications.
11. With the pail beneath the door spout, open the draw valve and relieve all pressure from the freezing cylinder. Remove the hopper cover. Slowly pour the sanitizing solution into the mix hopper until the hopper becomes 1/4 full of sanitizing solution.

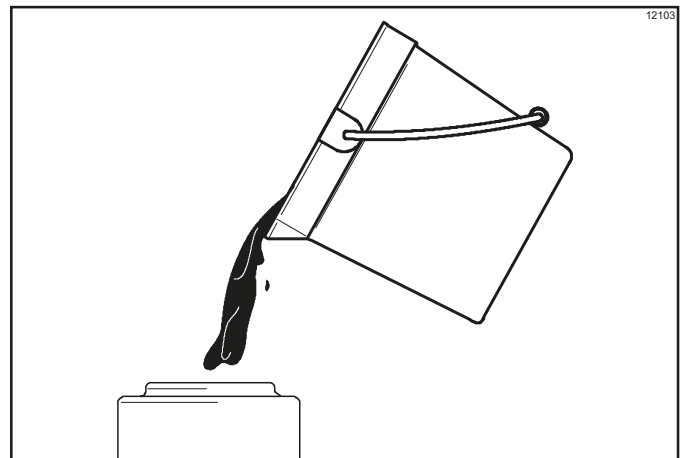

Figure 6-29

12. With the brushes provided, brush-clean the mix hopper, mix inlet hole, mix level float switch, product fitting, and mix feed tube. Use caution when cleaning the float switch so as not to damage it.

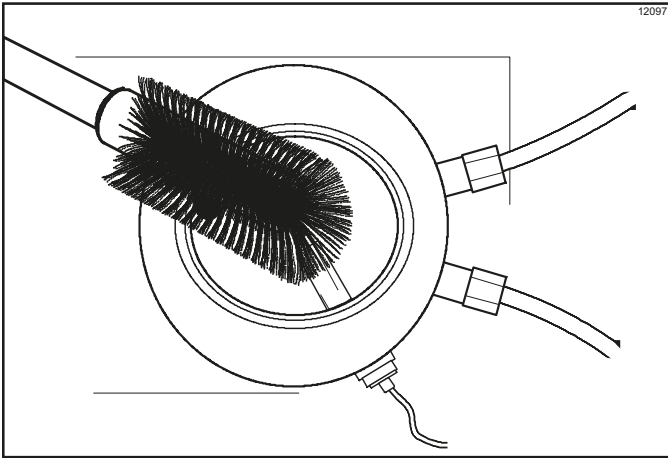

Figure 6-30

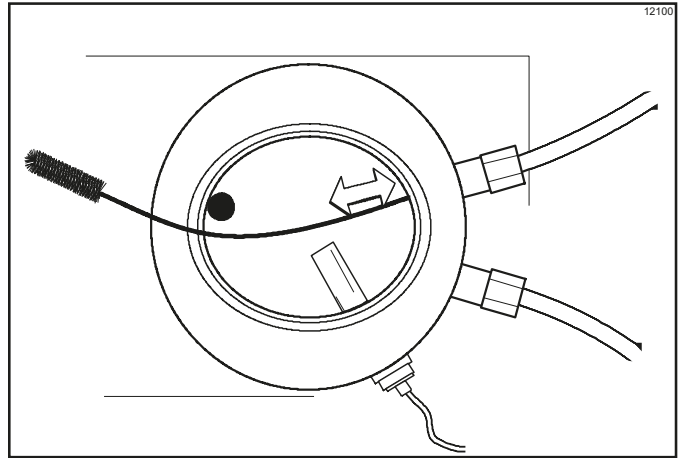

Figure 6-33

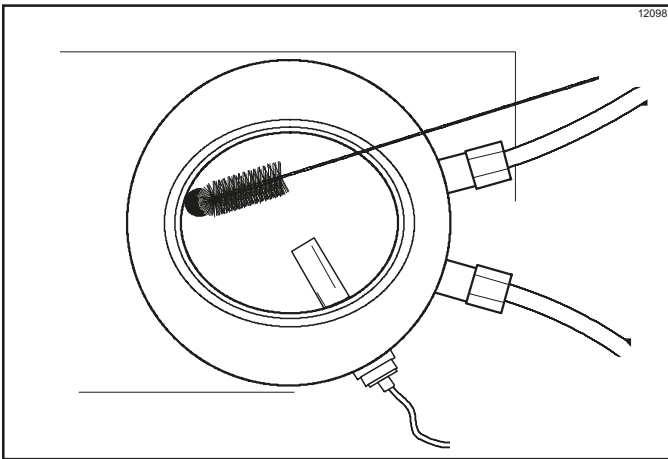

Figure 6-31

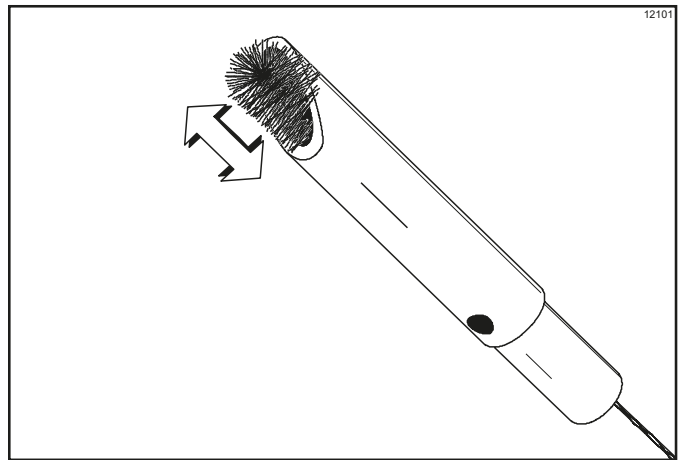

Figure 6-34

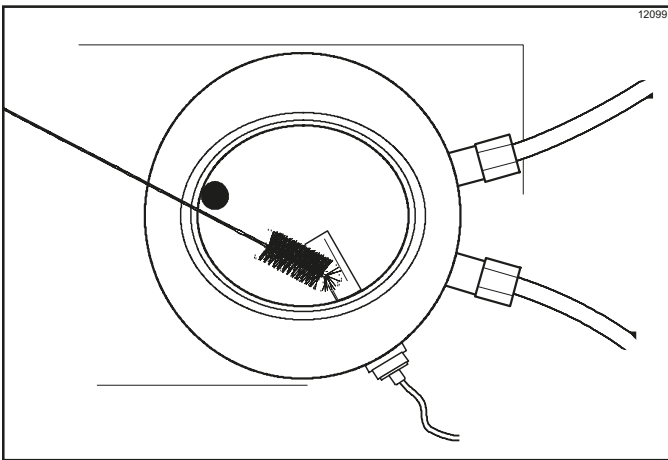

Figure 6-32

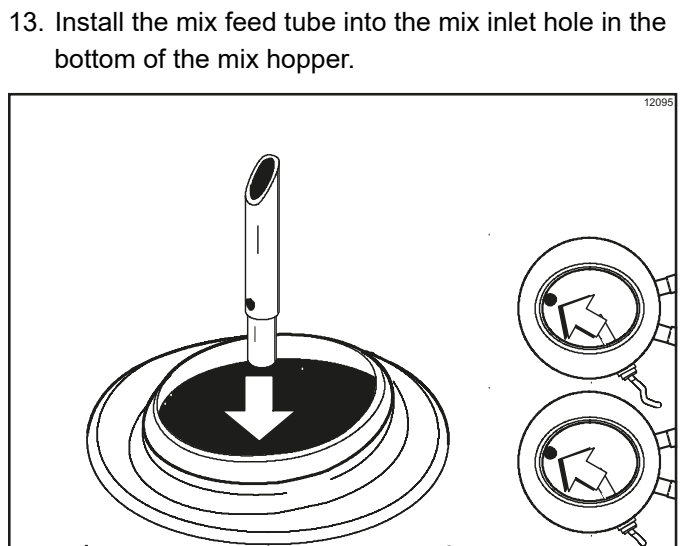

Figure 6-35

13. Install the mix feed tube into the mix inlet hole in the bottom of the mix hopper.

6

14. Sanitize and install the hopper cover. Lock the cover into place. Attach the vinyl tube to the pressure relief valve on the hopper cover. Position the open end of the vinyl tube into the rear drip pan.

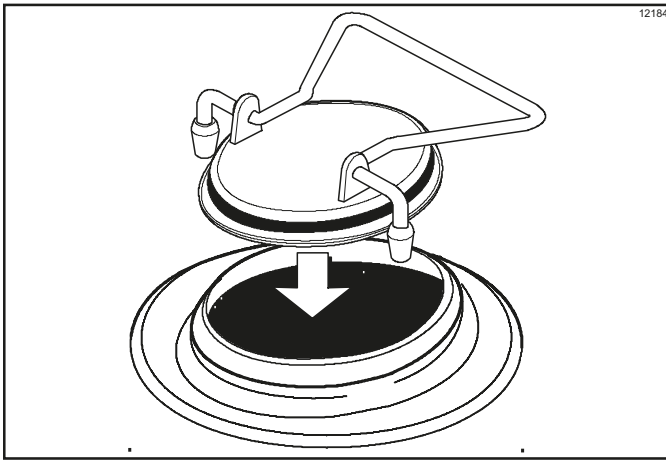

Figure 6-36

15. Press the BEATER key. Agitate the solution in the freezing cylinder for 5 minutes.

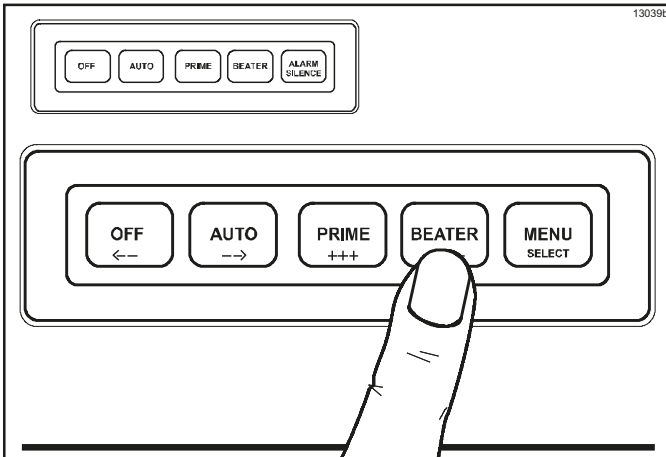

Figure 6-37

16. With a pail beneath the door spout, open the draw valve and drain all the solution from the mix hopper and the freezing cylinder. Press the OFF key, and close the draw valve.

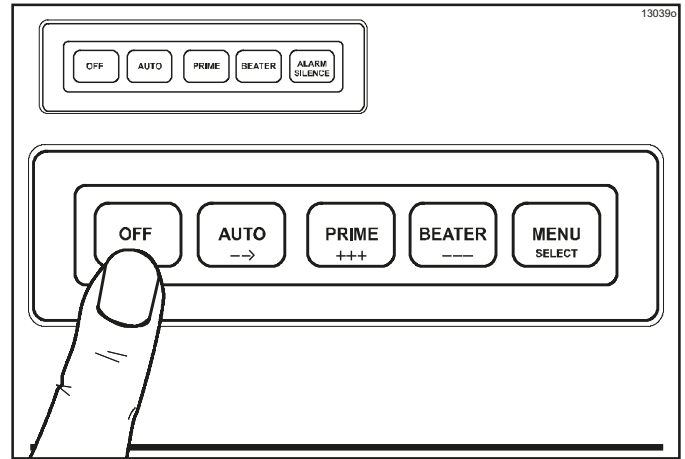

Figure 6-38

17. Disconnect the syrup connector in the sanitizing solution.

**Repeat step 2 through step 15** for the remaining freezing cylinder(s).

18. Remove the right side panel and install the rear white drip pan.

## Priming/Brixing

1. Connect the syrup line to the syrup tank (or the Bag-in-Box).
2. Press the BEATER key to pressurize the freezing cylinder.

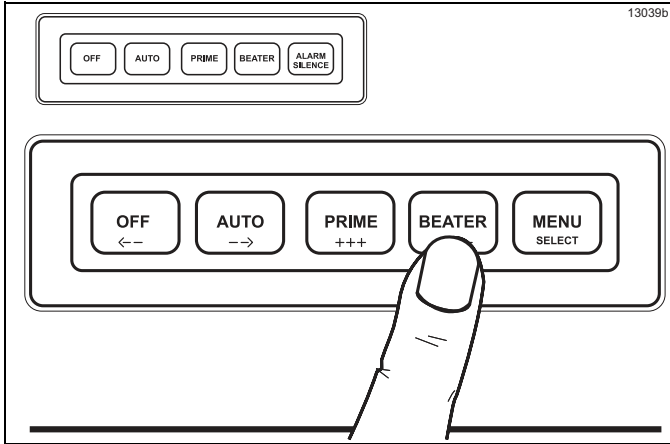

Figure 6-39

After three minutes, press the PRIME key. This will cause the product to flow to the mix hopper.

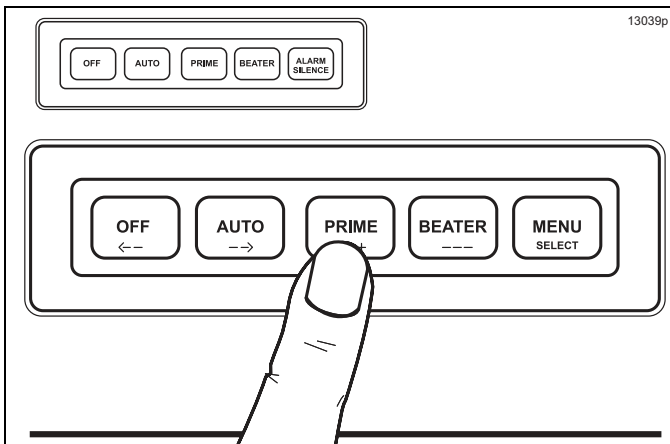

Figure 6-40

3. Raise the prime plug enough to allow a slight hissing sound.

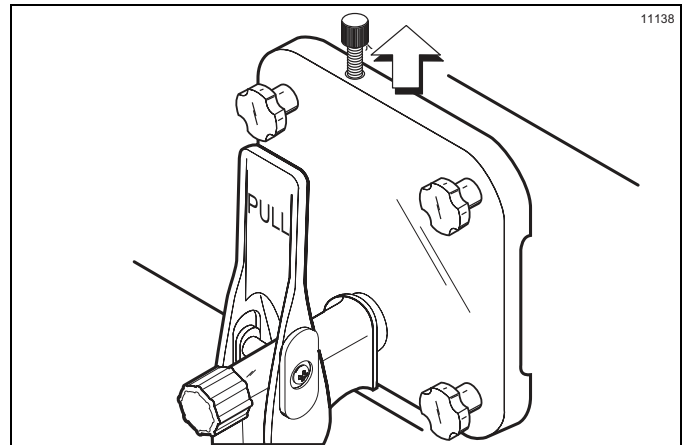

Figure 6-41

**Note:** The pressure in the freezing cylinder should be relieved slowly.

4. Slowly open the syrup sampling valve and let it run into a pail until all the sanitizer is removed and full-strength product is flowing. **Do not** open the valve so much that the syrup line to the hopper is drained.

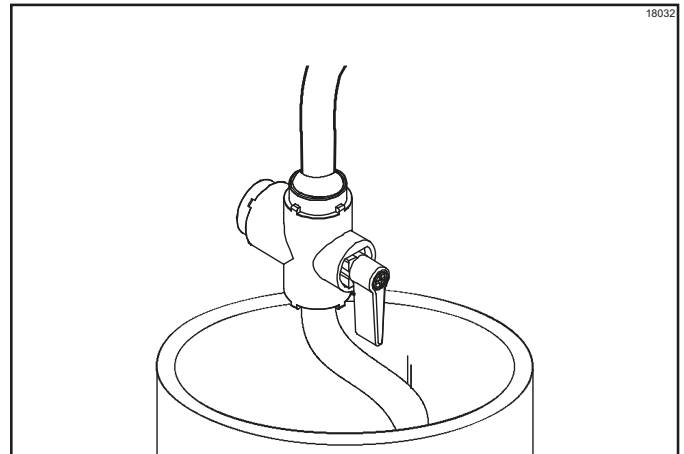

Figure 6-42

Brix is the ratio of syrup to water that will directly affect the quality and taste of the product. Brixing should be done before priming the freezer and when a change in syrup flavor has been made.

Allow the product to flow over the refractometer. The brix reading should register 13 to 14. A reading higher than this would cause a darker, richer product. The refrigeration system would have to run longer to freeze this excess syrup. A reading lower than this could cause a freeze-up in the freezing cylinder because of the excess water.

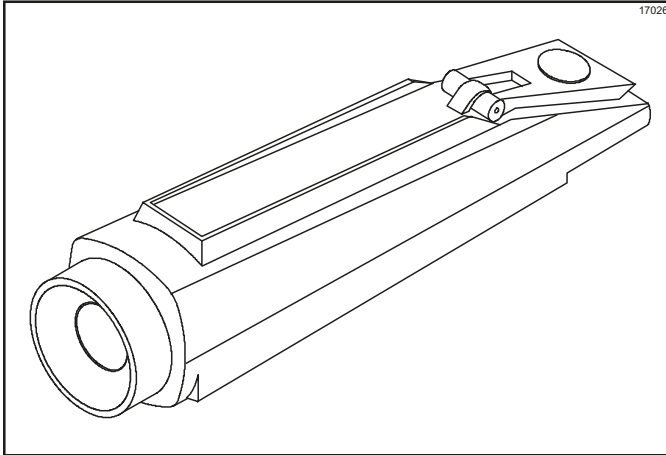

Figure 6-43

- To adjust the brix, turn the adjustment screw in the service panel. Clockwise adjustments increase the amount of syrup to water, and counterclockwise adjustments decrease the amount of syrup to water. Adjust the screw in small increments and check the brix again.

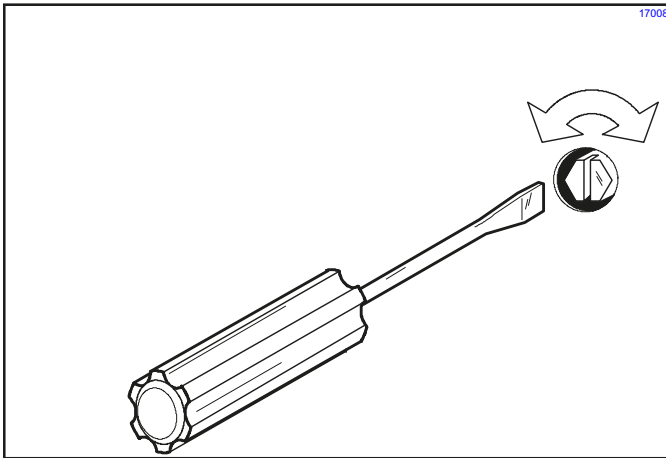

Figure 6-44

**Repeat this step** until a correct brix reading is registered.

- Once the proper brix has been achieved, close the sampling valve. Install the front drip tray and the splash shield on the front of the freezer.

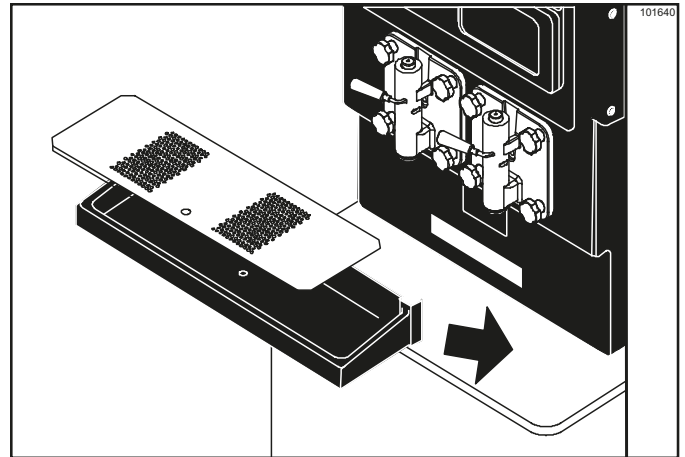

Figure 6-45

- With a pail beneath the door spout, press the BEATER key. Open the draw valve and drain the freezing cylinder. Close the draw valve. After 3 minutes, press the PRIME key. This will cause the product to flow to the mix hopper.
- Hold a large cup under the pressure relief port exit of the door, until the liquid level (not foam) reaches the pressure relief port. Lower the prime plug. Press the OFF key.

**Note:** A large amount of foam indicates that the prime plug was raised too high.

- Repeat step 1 through step 8** for the remaining freezing cylinder(s).
- To place the freezing cylinder in Auto mode, press the AUTO key. When the machine cycles off, the product will be at serving viscosity.

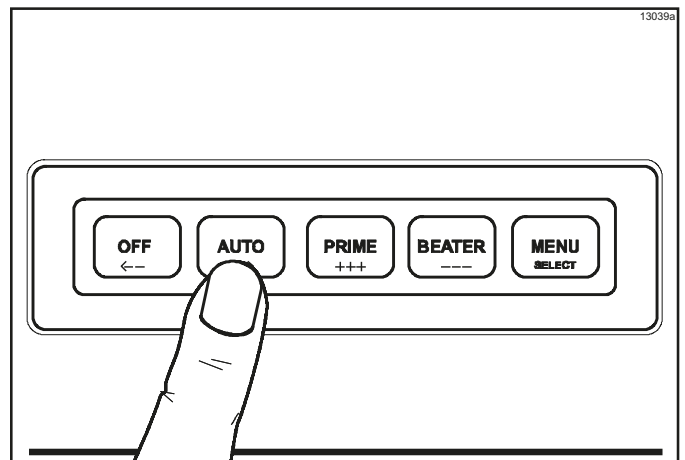

Figure 6-46

**Repeat this step** for the remaining freezing cylinder(s).

- Replace the side panels and close the lighted display. Install the hood in position on top of the freezer.

## 90 Day Closing Procedure

We recommend that the machine be completely disassembled and cleaned at least every 90 days using the following procedures.



To disassemble a freezer, the following items will be needed:

- Two cleaning pails
- Necessary brushes (provided with freezer)
- Cleaner
- Single-service towels

## Draining Product from the Freezing Cylinder

1. Press the BEATER key. This will allow the beater to operate. Open the draw valve and drain the product from the machine.

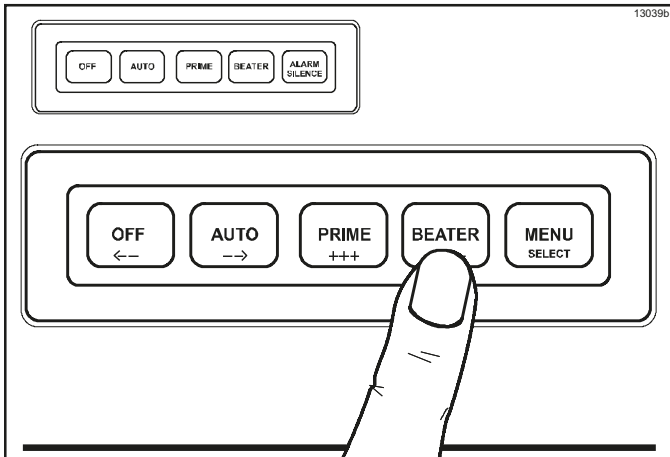

Figure 6-47

2. When all the product has been drained from the mix hopper and the freezing cylinder, close the draw valve, and press the OFF key. Properly discard this product.

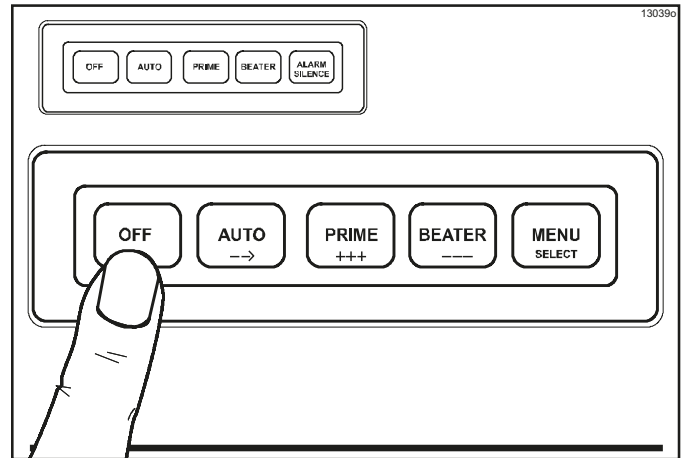

Figure 6-48

3. Repeat step 1 and step 2 for the remaining freezing cylinder(s).

## Cleaning

1. Open the lighted display door from the front of the machine. Remove the hood and side panels to gain access to the hoppers.
2. Prepare a pail of approved 100 PPM cleaning solution (examples: 2-1/2 gal. [9.5 L] of Kay-5<sup>®</sup> or 2 gal. [7.6 L] of Stera-Sheen<sup>®</sup>). Use warm water and follow the manufacturer's specifications.

**Important!** Make sure the cleaner is completely dissolved.

3. Pour the solution into a clean, empty pail. Place the syrup line with the old syrup connection into the pail of sanitizer.
4. Press the PRIME key. This will cause the cleaning solution to flow through the lines and into the mix hopper.
5. Remove the front drip tray. Place a pail beneath the sampling valve behind the front drip tray. Slowly open the sampling valve and allow the cleaner to flow through this line and out into the pail. After approximately 1/2 gal (1.9 L) of cleaner has been dispensed, close the valve.

6. Raise the prime plug. Place an empty pail under the door spout. When cleaning solution begins to exit the relief port opening in the freezer door, lower the prime plug. Press the OFF key. Open the draw valve and relieve all pressure from the freezing cylinder. Remove the hopper cover. Remove the mix feed tube and take it to the sink for further cleaning. Close the prime plug.
7. Prepare a pail of approved 100 PPM cleaning solution (examples: 2-1/2 gal. [9.5 L] of Kay-5® or 2 gal. [7.6 L] of Stera-Sheen®). Use warm water and follow the manufacturer's specifications.
8. Slowly pour the cleaning solution into the mix hopper until the hopper becomes 1/4 full of cleaning solution.
9. With the brushes provided, brush-clean the mix hopper, mix inlet hole, mix level float switch, and product fitting.
 

**Important!** Use caution when cleaning the float switch. Failure to do so will cause damage to the component.
10. Clean and install the hopper cover. Lock the cover into place. Attach the vinyl tube to the pressure relief valve on the hopper cover. Position the open end of the vinyl tube into the rear drip pan.
11. Press the BEATER key to agitate the solution in the freezing cylinder.
12. With a pail beneath the door spout, open the draw valve and drain all the solution from the mix hopper and the freezing cylinder. Press the OFF key and close the draw valve.
13. Disconnect the syrup connector.
14. **Repeat step 2 through step 13** for the remaining freezing cylinder(s).

## Disassembly

1. Make sure the control switch is in the OFF position. Open the draw valves to make sure all pressure has been relieved.
2. Raise the prime plug. Leave the bleed port open when removing the freezer door to make sure all pressure is relieved from the freezing cylinder.
3. Remove the following parts from the freezer, and take them to the sink for brush-cleaning: handscrews, freezer doors, baffle assemblies, beater assemblies, scraper blades, drive shafts, hopper covers, front drip tray, and splash shield.

## Brush Cleaning

1. Prepare a sink with an approved cleaning solution. (examples: Kay-5® or Stera-Sheen®). Use warm water and follow the manufacturer's specifications.

**Important!** Follow the label directions. Too **strong** of a solution can cause parts damage, while too **mild** of a solution will not provide adequate cleaning. Make sure all brushes provided with the freezer are available for brush cleaning.

2. Return to the freezer with a small amount of cleaning solution. With a single-service towel, wipe clean the bearing surface. Brush-clean the rear shell bearings at the back of the freezing cylinders with the black bristle brush.

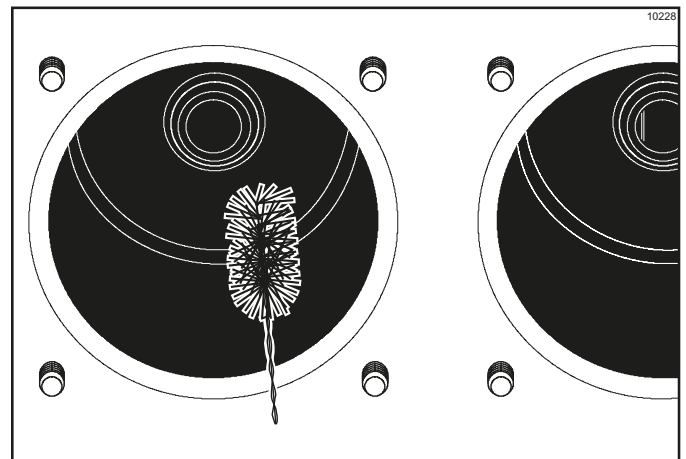

Figure 6-49

## OPERATING PROCEDURES

---

3. Remove the rear drip pan (this does not apply to Model 349).
4. Remove the right side panel and take the white rear drip pan to the sink for further cleaning.
5. Remove the following parts: seals and O-rings from the drive shafts, drive shaft seal bushings from drive shaft seals, caps and springs from freezer doors, screws and draw handle slides from freezer doors, pivot pins from draw valves, draw valve handles from freezer doors, draw valves from freezer doors, O-rings from draw valves, prime plugs from freezer doors, O-rings from prime plugs, O-rings and front bearings from freezer doors, O-rings from mix hopper covers.

Discard all O-rings and replace them with new ones.

**Note:** To remove O-rings, use a single-service towel to grasp the O-ring. Apply pressure in an upward direction until the O-ring pops out of its groove. With the other hand, push the top of the O-ring forward. It will roll out of the groove and can be easily removed. If there is more than one O-ring to be removed, always remove the rear O-ring first. This will allow the O-ring to slide over the forward rings without falling into the open grooves.

6. Using a single-service towel, wipe the lubricant off the parts. Brush-clean all disassembled parts in the cleaning solution. Make sure all lubricant and syrup is removed. Place all the cleaned parts on a clean, dry surface to air-dry.
7. Wipe clean all the exterior surfaces of the freezer.

## During Cleaning and Sanitizing



**ALWAYS FOLLOW LOCAL HEALTH CODES.**

Cleaning and sanitizing schedules are governed by your state or local regulatory agencies and must be followed accordingly. The following checkpoints should be stressed during the cleaning and sanitizing operations.

**Important!** *General cleaning and sanitizing must be performed daily. A thorough cleaning every 90 days is also recommended.*

## Troubleshooting Bacterial Count

- Thoroughly clean and sanitize the machine regularly, including complete disassembly and brush-cleaning.
- Use all brushes supplied for thorough cleaning. The brushes are specially designed to reach all product passageways.
- Use the white bristle brush to clean the mix inlet hole, which extends from the mix hopper down to the rear of the freezing cylinder.
- Use the black bristle brush to thoroughly clean the rear shell bearing located at the rear of the freezing cylinder. Use a generous amount of cleaning solution on the brush.
- Using a screwdriver and a cloth towel, keep the rear shell bearing and the female hex drive socket clean and free of lubricant and product deposits.
- Properly prepare the cleaning and sanitizing solutions. Read and follow the label directions carefully. Too **strong** of a solution may damage the parts, and too **weak** of a solution will not do an adequate job of cleaning or sanitizing.
- Clean and sanitize the syrup lines regularly to prevent syrup residue buildup that would restrict the proper flow of syrup.
- On a regular basis, take a brix reading to ensure a consistent quality product.

## Regular Maintenance Checks

- Replace scraper blades that are nicked, damaged, or worn down.
- Before installing the beater, make sure that the scraper blades are properly attached over the pins.
- Check the rear shell bearing for signs of wear (excessive product leakage from the rear drip pans to the front drip tray).
- Dispose of O-rings and seals if they are worn, torn, or fit too loosely, and replace with new ones.
- Follow all lubricating procedures as outlined in the Assembly section. (See “Assembly” on page 6-1.)
- Check the condenser(s) for dirt and lint. Dirty condensers will reduce the efficiency and capacity of the machine. Condensers should be cleaned monthly by removing and cleaning the poly-flo filter. Remove the service panel and side panels to expose the condenser(s). Never use screwdrivers or other metal probes to clean between the fins.

### Winter Storage

If the place of business is to be closed during the winter months, it is important to protect the freezer by following certain precautions, particularly if the building is subject to freezing conditions.

Disconnect the freezer from the main power source to prevent possible electrical damage. Your local Taylor distributor can perform this service for you.

Wrap detachable parts of the freezer (such as the beater, scraper blades, drive shaft, and freezer door) and place them in a protected, dry place. Rubber trim parts and gaskets can be protected by wrapping them with moisture-proof paper. All parts should be thoroughly cleaned of dried mix or lubrication, which can attract mice and other vermin.

**Note:** *It is recommended that an authorized service technician perform winter storage draining, to ensure all water has been removed. This will prevent the components from freezing and rupturing.*

Table 8-1

Problem	Probable Cause	Remedy	Page Ref.
1. Product is too stiff.	<ul style="list-style-type: none"> <li>a. Too much water-to- syrup ratio. Improper brix adjustment.</li> <li>b. Consistency control needs adjustment.</li> <li>c. Torque coupling bound in warm position.</li> </ul>	<ul style="list-style-type: none"> <li>a. Adjust the brix accordingly.</li> <li>b. Contact a service technician.</li> <li>c. Contact a service technician.</li> </ul>	<ul style="list-style-type: none"> <li>6-10</li> <li>---</li> <li>---</li> </ul>
2. Product is too soft.	<ul style="list-style-type: none"> <li>a. Freezer in a defrost cycle.</li> <li>b. Consistency control needs adjustment.</li> <li>c. Torque coupling bound in cold position.</li> <li>d. Broken springs in torque coupling.</li> </ul>	<ul style="list-style-type: none"> <li>a. Wait for defrost cycle to end.</li> <li>b. Contact a service technician.</li> <li>c. Contact a service technician.</li> <li>d. Contact a service technician.</li> </ul>	<ul style="list-style-type: none"> <li>---</li> <li>---</li> <li>---</li> <li>---</li> </ul>
3. No product is being dispensed.	<ul style="list-style-type: none"> <li>a. Product frozen up in freezing cylinder.</li> </ul>	<ul style="list-style-type: none"> <li>a. See problem number one.</li> </ul>	<ul style="list-style-type: none"> <li>---</li> </ul>
4. Freezer will not operate in the Beater or Auto mode.	<ul style="list-style-type: none"> <li>a. Machine is unplugged.</li> <li>b. Blown fuse, or the circuit breaker is off.</li> <li>c. Beater motor is out on overload. Check fault description screen.</li> </ul>	<ul style="list-style-type: none"> <li>a. Check the plug at wall receptacle.</li> <li>b. Replace the fuse or turn the breaker on.</li> <li>c. Allow the motor to cool. Press the AUTO key. Contact a service technician if the beater motor goes out on overload again.</li> </ul>	<ul style="list-style-type: none"> <li>---</li> <li>---</li> <li>5-3</li> </ul>
5. No compressor operation in the Auto mode.	<ul style="list-style-type: none"> <li>a. Beater motor is out on overload. Check the fault description screen.</li> <li>b. The torque coupling is bound in the cold position.</li> <li>c. Condenser dirty, A/C.</li> <li>d. Water supply off, W/C.</li> </ul>	<ul style="list-style-type: none"> <li>a. Allow the motor to cool. Press the AUTO key. Contact a service technician if the beater motor goes out on overload again.</li> <li>b. Contact a service technician.</li> <li>c. Clean condenser monthly.</li> <li>d. Turn the water on.</li> </ul>	<ul style="list-style-type: none"> <li>5-3</li> <li>---</li> <li>7-1</li> <li>---</li> </ul>
6. Unable to remove the drive shaft from the rear shell bearing.	<ul style="list-style-type: none"> <li>a. Rounded corners of hex end of drive shaft, drive coupling, or both.</li> <li>b. Lubrication of hex end of drive shaft.</li> </ul>	<ul style="list-style-type: none"> <li>a. Replace the drive shaft, or contact a service technician to replace the direct drive unit.</li> <li>b. Do not lubricate the hex end. If necessary, contact a service technician for removal.</li> </ul>	<ul style="list-style-type: none"> <li>---</li> <li>6-1</li> </ul>
7. Excessive loss of CO <sub>2</sub> .	<ul style="list-style-type: none"> <li>a. Leak in the CO<sub>2</sub> system.</li> </ul>	<ul style="list-style-type: none"> <li>a. Contact a service technician.</li> </ul>	<ul style="list-style-type: none"> <li>---</li> </ul>
8. Leakage from rear drip pan(s) into front drip tray.	<ul style="list-style-type: none"> <li>a. Seal or O-ring on drive shaft is worn, missing, or incorrectly installed.</li> <li>b. Worn rear shell bearing.</li> </ul>	<ul style="list-style-type: none"> <li>a. Replace or install correctly on drive shaft.</li> <li>b. Contact a service technician to replace rear shell bearing.</li> </ul>	<ul style="list-style-type: none"> <li>6-1</li> <li>---</li> </ul>

## TROUBLESHOOTING GUIDE

Problem	Probable Cause	Remedy	Page Ref.
9. Excessive mix leakage from door spout.	a. Inadequate lubrication of draw valve O-rings.	a. Lubricate properly.	6-1
	b. Wrong type of lubricant on draw valve O-rings.	b. Use food grade lubricant (example: Taylor Lube HP).	6-1
	c. Worn or missing draw valve O-rings.	c. Replace or install O-rings on draw valve.	6-1 / 9-1
10. Unable to adjust brix.	a. Syrup lines need to be cleaned and sanitized.	a. Clean and sanitize syrup lines.	- - -
	b. Blocked flow control.	b. Contact a service technician.	- - -
11. Lack of syrup being supplied to machine.	a. Loss of CO <sub>2</sub> to propel syrup.	a. Contact a service technician.	- - -
	b. Clogged or kinked syrup lines.	b. Sanitize syrup lines regularly. If kinked, repair or replace.	- - -
12. Product does not enter mix hopper.	a. Machine is not in the Auto or Prime mode.	a. Place the machine in the Auto or Prime mode.	6-10
	b. The mix level float switch is inoperative.	b. Contact a service technician.	- - -
13. Carbonated water or sulfuric aroma is evident in the faucet or sewage system.	a. Faulty check valve in carbonation system.	a. Contact a service technician to replace the check valve.	- - -

# Section 9

# Parts Replacement Schedule

Table 9-1

Part Description	Every 3 Months	Every 6 Months	Annually
Scraper Blade		X	Minimum
Drive Shaft Seal	X		
Drive Shaft O-ring	X		
Freezer Door O-ring	X		
Draw Valve O-ring	X		
Door Spout O-ring	X		
Hopper Cover O-ring	X		
Front Bearing	X		
Prime Plug O-Ring	X		
White Bristle Brush, 3" x 7"		Inspect and replace if necessary.	Minimum
Double-Ended Brush		Inspect and replace if necessary.	Minimum
White Bristle Brush, 1-1/2" x 2"		Inspect and replace if necessary.	Minimum
Black Bristle Brush, 1" x 2"		Inspect and replace if necessary.	Minimum



## TAYLOR COMPANY LIMITED WARRANTY ON FREEZERS

Taylor Company is pleased to provide this limited warranty on new Taylor-branded freezer equipment available from Taylor to the market generally (the "Product") to the original purchaser only.

### LIMITED WARRANTY

Taylor warrants the Product against failure due to defect in materials or workmanship under normal use and service as follows. All warranty periods begin on the date of original Product installation. If a part fails due to defect during the applicable warranty period, Taylor, through an authorized Taylor distributor or service agency, will provide a new or remanufactured part, at Taylor's option, to replace the failed defective part at no charge for the part. Except as otherwise stated herein, these are Taylor's exclusive obligations under this limited warranty for a Product failure. This limited warranty is subject to all provisions, conditions, limitations, and exclusions listed below and on the reverse (if any) of this document.

Table 10-1

Product	Part	Limited Warranty Period
<b>Soft Serve</b>	Insulated Shell Assembly	Five (5) years
<b>Frozen Yogurt Shakes</b>	Refrigeration Compressor (Except Service Valve)	Five (5) years
<b>Smoothies</b>	Beater Motors	Two (2) years
<b>Frozen Beverage</b>	Beater Drive Gear	Two (2) years
<b>Batch Desserts</b>	Printed Circuit Boards and Softech Controls beginning with serial number H8024200	Two (2) years
	Parts not otherwise listed in this table or excluded below	One (1) year

### LIMITED WARRANTY CONDITIONS

1. If the date of original installation of the Product cannot be verified, then the limited warranty period begins ninety (90) days from the date of Product manufacture (as indicated by the Product serial number). Proof of purchase may be required at time of service.
2. This limited warranty is valid only if the Product is installed and all required service work on the Product is performed by an authorized Taylor distributor or service agency, and only if genuine, new Taylor parts are used.
3. Installation, use, care, and maintenance must be normal and in accordance with all instructions contained in the Taylor Operator's Manual.
4. Defective parts must be returned to the authorized Taylor distributor or service agency for credit.
5. The use of any refrigerant other than that specified on the Product's data label will void this limited warranty.

### LIMITED WARRANTY EXCEPTIONS

This limited warranty does **not** cover:

1. Labor or other costs incurred for diagnosing, repairing, removing, installing, shipping, servicing, or handling of defective parts, replacement parts, or new Products.
2. Normal maintenance, cleaning, and lubrication as outlined in the Taylor Operator's Manual, including cleaning of condensers.
3. Replacement of wear items designated as Class "000" parts in the Taylor Operator's Manual.
4. External hoses, electrical power supplies, and machine grounding.

## LIMITED WARRANTY ON EQUIPMENT

---

5. Parts not supplied or designated by Taylor, or damages resulting from their use.
6. Return trips or waiting time required because a service technician is prevented from beginning warranty service work promptly upon arrival.
7. Failure, damage, or repairs due to faulty installation, misapplication, abuse, no or improper servicing, unauthorized alteration or improper operation or use as indicated in the Taylor Operator's Manual, including but not limited to the failure to use proper assembly and cleaning techniques, tools, or approved cleaning supplies.
8. Failure, damage, or repairs due to theft, vandalism, wind, rain, flood, high water, water, lightning, earthquake, or any other natural disaster, fire, corrosive environments, insect or rodent infestation, or other casualty, accident, or condition beyond the reasonable control of Taylor; operation above or below the electrical or water supply specification of the Product; or components repaired or altered in any way so as, in the judgment of the Manufacturer, to adversely affect performance, or normal wear or deterioration.
9. Any Product purchased over the Internet.
10. Failure to start due to voltage conditions, blown fuses, open circuit breakers, or damages due to the inadequacy or interruption of electrical service.
11. Electricity or fuel costs, or increases in electricity or fuel costs from any reason whatsoever.
12. Damages resulting from the use of any refrigerant other than that specified on the Product's data label will void this limited warranty.
13. Any cost to replace, refill, or dispose of refrigerant, including the cost of refrigerant.
14. **ANY SPECIAL, INDIRECT, OR CONSEQUENTIAL PROPERTY OR COMMERCIAL DAMAGE OF ANY NATURE WHATSOEVER.** Some jurisdictions do not allow the exclusion of incidental or consequential damages, so this limitation may not apply to you.

This limited warranty gives you specific legal rights, and you may also have other rights which vary from jurisdiction to jurisdiction.

### LIMITATION OF WARRANTY

**THIS LIMITED WARRANTY IS EXCLUSIVE AND IS IN LIEU OF ALL OTHER WARRANTIES, CONDITIONS, AND/OR REMEDIES UNDER THE LAW, INCLUDING ANY IMPLIED WARRANTIES OR CONDITIONS OF MERCHANTABILITY OR FITNESS FOR A PARTICULAR PURPOSE. THE ORIGINAL OWNER'S SOLE REMEDY WITH RESPECT TO ANY PRODUCTS SHALL BE REPAIR OR REPLACEMENT OF DEFECTIVE COMPONENTS UNDER THE TERMS OF THIS LIMITED WARRANTY. ALL RIGHTS TO CONSEQUENTIAL OR INCIDENTAL DAMAGES (INCLUDING CLAIMS FOR LOST SALES, LOST PROFITS, PRODUCT LOSS, PROPERTY DAMAGES, OR SERVICE EXPENSES) ARE EXPRESSLY EXCLUDED. THE EXPRESS WARRANTIES MADE IN THIS LIMITED WARRANTY MAY NOT BE ALTERED, ENLARGED, OR CHANGED BY ANY DISTRIBUTOR, DEALER, OR OTHER PERSON, WHATSOEVER.**

### LEGAL REMEDIES

The owner **must** notify Taylor in writing, by certified or registered letter to the following address, of any defect or complaint with the Product, stating the defect or complaint and a specific request for repair, replacement, or other correction of the Product under warranty, mailed at least thirty (30) days before pursuing any legal rights or remedies.

Taylor Company  
750 N. Blackhawk Blvd.  
Rockton, IL 61072, U.S.A.

## TAYLOR COMPANY LIMITED WARRANTY ON GENUINE TAYLOR PARTS

Taylor Company is pleased to provide this limited warranty on new Taylor genuine replacement components and parts available from Taylor to the market generally (the “Parts”) to the original purchaser only.

### LIMITED WARRANTY

Taylor warrants the Parts against failure due to defect in materials or workmanship under normal use and service as follows. All warranty periods begin on the date of original installation of the Part in the Taylor unit. If a Part fails due to defect during the applicable warranty period, Taylor, through an authorized Taylor distributor or service agency, will provide a new or remanufactured Part, at Taylor’s option, to replace the failed defective Part at no charge for the Part. Except as otherwise stated herein, these are Taylor’s exclusive obligations under this limited warranty for a Part failure. This limited warranty is subject to all provisions, conditions, limitations, and exclusions listed below and on the reverse (if any) of this document.

Table 11-1

Parts Warranty Class Code or Part	Limited Warranty Period
Class 103 Parts <sup>1</sup>	Three (3) Months
Class 212 Parts <sup>2</sup>	Twelve (12) Months
Class 512 Parts	Twelve (12) Months
Class 000 Parts	No Warranty

### LIMITED WARRANTY CONDITIONS

1. If the date of original installation of the Part cannot be otherwise verified, proof of purchase may be required at time of service.
2. This limited warranty is valid only if the Part is installed and all required service work in connection with the Part is performed by an authorized Taylor distributor or service agency.
3. The limited warranty applies only to Parts remaining in use by their original owner at their original installation location in the unit of original installation.
4. Installation, use, care, and maintenance must be normal and in accordance with all instructions contained in the Taylor Operator’s Manual.
5. Defective Parts must be returned to the authorized Taylor distributor or service agency for credit.
6. This warranty is not intended to shorten the length of any warranty coverage provided pursuant to a separate Taylor Limited Warranty on freezer or grill equipment.
7. The use of any refrigerant other than that specified for the unit in which the Part is installed will void this limited warranty.

<sup>1, 2</sup> Except that Taylor Part #032129SER2 (Compressor-Air-230V SERV) and Taylor Part #075506SER1 (Compressor-Air-115V 60HZ) shall have a limited warranty period of twelve (12) months when used in Taylor freezer equipment and a limited warranty period of two (2) years when used in Taylor grill equipment.

## LIMITED WARRANTY ON PARTS

---

### LIMITED WARRANTY EXCEPTIONS

This limited warranty does **not** cover:

1. Labor or other costs incurred for diagnosing, repairing, removing, installing, shipping, servicing, or handling of defective Parts, replacement Parts, or new Parts.
2. Normal maintenance, cleaning, and lubrication as outlined in the Taylor Operator's Manual, including cleaning of condensers or carbon and grease buildup.
3. Required service, whether cleaning or general repairs, to return the cooking surface assemblies, including the upper platen and lower plate, to an operational condition to achieve proper cooking or allow proper assembly of release sheets and clips as a result of grease buildup on the cooking surfaces, including but not limited to the platen and plate, sides of the shroud, or top of the shroud.
4. Replacement of cooking surfaces, including the upper platen and lower plate, due to pitting or corrosion (or in the case of the upper platen, due to loss of plating) as a result of damage due to the impact of spatulas or other small wares used during the cooking process or as a result of the use of cleaners, cleaning materials, or cleaning processes not approved for use by Taylor.
5. Replacement of wear items designated as Class "000" Parts in the Taylor Operator's Manual, as well as any release sheets and clips for the Product's upper platen assembly.
6. External hoses, electrical power supplies, and machine grounding.
7. Parts not supplied or designated by Taylor, or damages resulting from their use.
8. Return trips or waiting time required because a service technician is prevented from beginning warranty service work promptly upon arrival.
9. Failure, damage, or repairs due to faulty installation, misapplication, abuse, no or improper servicing, unauthorized alteration, or improper operation or use as indicated in the Taylor Operator's Manual, including but not limited to the failure to use proper assembly and cleaning techniques, tools, or approved cleaning supplies.
10. Failure, damage, or repairs due to theft, vandalism, wind, rain, flood, high water, water, lightning, earthquake, or any other natural disaster, fire, corrosive environments, insect or rodent infestation, or other casualty, accident, or condition beyond the reasonable control of Taylor; operation above or below the gas, electrical, or water supply specification of the unit in which a part is installed; or Parts or the units in which they are installed repaired or altered in any way so as, in the judgment of Taylor, to adversely affect performance, or normal wear or deterioration.
11. Any Part purchased over the Internet.
12. Failure to start due to voltage conditions, blown fuses, open circuit breakers, or damages due to the inadequacy or interruption of electrical service.
13. Electricity, gas, or other fuel costs, or increases in electricity or fuel costs from any reason whatsoever.
14. Damages resulting from the use of any refrigerant other than that specified for the unit in which the Part is installed will void this limited warranty.
15. Any cost to replace, refill, or dispose of refrigerant, including the cost of refrigerant.
16. **ANY SPECIAL, INDIRECT, OR CONSEQUENTIAL PROPERTY OR COMMERCIAL DAMAGE OF ANY NATURE WHATSOEVER.** Some jurisdictions do not allow the exclusion of incidental or consequential damages, so this limitation may not apply to you.

This limited warranty gives you specific legal rights, and you may also have other rights which vary from jurisdiction to jurisdiction.

**LIMITATION OF WARRANTY**

**THIS LIMITED WARRANTY IS EXCLUSIVE AND IS IN LIEU OF ALL OTHER WARRANTIES, CONDITIONS, AND/ OR REMEDIES UNDER THE LAW, INCLUDING ANY IMPLIED WARRANTIES OR CONDITIONS OF MERCHANTABILITY OR FITNESS FOR A PARTICULAR PURPOSE. THE ORIGINAL OWNER'S SOLE REMEDY WITH RESPECT TO ANY PRODUCTS SHALL BE REPAIR OR REPLACEMENT OF DEFECTIVE PARTS UNDER THE TERMS OF THIS LIMITED WARRANTY. ALL RIGHTS TO CONSEQUENTIAL OR INCIDENTAL DAMAGES (INCLUDING CLAIMS FOR LOST SALES, LOST PROFITS, PRODUCT LOSS, PROPERTY DAMAGES, OR SERVICE EXPENSES) ARE EXPRESSLY EXCLUDED. THE EXPRESS WARRANTIES MADE IN THIS LIMITED WARRANTY MAY NOT BE ALTERED, ENLARGED, OR CHANGED BY ANY DISTRIBUTOR, DEALER, OR OTHER PERSON, WHATSOEVER.**

**LEGAL REMEDIES**

The owner **must** notify Taylor in writing by certified or registered letter to the following address of any defect or complaint with the Part, stating the defect or complaint and a specific request for repair, replacement, or other correction of the Part under warranty, mailed at least thirty (30) days before pursuing any legal rights or remedies.

Taylor Company  
750 N. Blackhawk Blvd.  
Rockton, IL 61072, U.S.A.

