

# OPERATOR'S MANUAL



## Model 430 Torque Shake/Slush Freezer

Original Operating Instructions

051430-M

3/97 (Original Publication)  
(Updated 8/10/2020)



## Section 1: To the Installer

Installer Safety . . . . .	1-1
Site Preparation . . . . .	1-1
Air-Cooled Units . . . . .	1-2
Water Connections . . . . .	1-2
Electrical Connections. . . . .	1-2
Beater Rotation . . . . .	1-3
Refrigerant . . . . .	1-4

## Section 2: To the Operator

Compressor Warranty Disclaimer . . . . .	2-2
--	-----

## Section 3: Safety

## Section 4: Operator Parts Identification

Exploded View . . . . .	4-1
Beater Door. . . . .	4-2
Accessories. . . . .	4-3

## Section 5: User Interface

Viscosity Adjustment. . . . .	5-1
Power Switch . . . . .	5-1
Reset Button . . . . .	5-1
Indicator Lights . . . . .	5-1

## Section 6: Operating Procedures

Assembly. . . . .	6-1
Sanitizing. . . . .	6-5
Priming . . . . .	6-6
Closing Procedures. . . . .	6-7
Draining Product from the Freezing Cylinder . . . . .	6-7
Rinsing . . . . .	6-8
Cleaning . . . . .	6-8
Disassembly . . . . .	6-8
Brush Cleaning . . . . .	6-9

# Table of Contents

---

## **Section 7: Operator Checklist**

During Cleaning and Sanitizing .....	7-1
Troubleshooting Bacterial Count .....	7-1
Regular Maintenance Checks.....	7-1
Winter Storage .....	7-2

## **Section 8: Troubleshooting**

## **Section 9: Parts Replacement Schedule**

## **Section 10: Limited Warranty on Equipment**

## **Section 11: Limited Warranty on Parts**

The following information has been included in the manual as safety and regulatory guidelines. For complete installation instructions, please see the Installation Checklist.

## Installer Safety



**IMPORTANT!** *In all areas of the world, equipment should be installed in accordance with existing local codes. Please contact your local authorities if you have any questions.*

*Care should be taken to ensure that all basic safety practices are followed during the installation and servicing activities related to the installation and service of Taylor® equipment.*

- *Only authorized Taylor service personnel should perform installation, maintenance, and repairs on Taylor equipment.*
- *Authorized service personnel should consult OSHA Standard 29CFR1910.147 or the applicable code of the local area for the industry standards on lockout/tagout procedures before beginning any installation or repairs.*
- *Authorized service personnel must ensure that the proper protective equipment (PPE) is available and worn when required during installation and service.*
- *Authorized service personnel must remove all metal jewelry, rings, and watches before working on electrical equipment.*



**DANGER!** The main power supply(s) to the unit must be disconnected prior to performing any installation, maintenance, or repairs. Failure to follow this instruction may result in personal injury or death from electrical shock or hazardous moving parts as well as poor performance or damage to the unit.



**WARNING!** This unit has many sharp edges that can cause severe injuries.

## Site Preparation

Review the area where the unit will be installed before uncrating the unit. Make sure that all possible hazards to the user and the equipment have been addressed.

**For Indoor Use Only:** This unit is designed to operate indoors, under normal ambient temperatures of 70°F to 75°F (21°C to 24°C). The freezer has successfully performed in high ambient temperatures of 104°F (40°C) at reduced capacities.



**WARNING!** This unit must **NOT** be installed in an area where a water jet or hose can be used. **NEVER** use a water jet or hose to rinse or clean the unit. Failure to follow this instruction may result in electrocution.



**IMPORTANT!** *This machine is to be used only by trained personnel. It is not intended for use, cleaning, or maintenance by children or people with reduced physical, sensory, or mental capabilities, or lack of experience and knowledge, unless given supervision or instruction concerning the use of the machine by a person responsible for their safety. Children should be supervised to ensure that they do not play with the machine.*



**WARNING!** Only install this machine in a location where its use and maintenance is restricted to trained personnel. Failure to comply may result in personal injury.



**CAUTION!** This unit must be installed on a level surface to avoid the hazard of tipping. Extreme care should be taken in moving this unit for any reason. Two or more persons are required to safely move this unit. Failure to comply may result in personal injury or damage to the unit.

The authorized installer should inspect the unit for damage and promptly report any damage to the local authorized Taylor distributor.

This unit is made using USA sizes of hardware. All metric conversions are approximate and vary in size.

### Air-Cooled Units

**Do not** obstruct air intake and discharge openings. Air-cooled units require a minimum of 3 in. (76.2 mm) of clearance on the left and right sides of the freezer to allow for adequate air flow across the condenser. Failure to allow adequate clearance can reduce the refrigeration capacity of the freezer and possibly cause permanent damage to the compressor.

### Water Connections

#### (Water-Cooled Units Only)

An adequate cold water supply must be provided with a hand shutoff valve. On the underside rear of the base pan, two 3/8 in. IPS water connections for inlet and outlet have been provided for easy hookup. Permanently connect the machine using 1/2 in. (12.7 mm) inside diameter water lines. (Flexible lines are recommended, if local codes permit.) Depending on local water conditions, it may be advisable to install a water strainer to prevent foreign substances from clogging the automatic water valve. There will be only one water “in” and one water “out” connection. **Do not** install a hand shutoff valve on the water “out” line. Water should always flow in this order: first through the automatic water valve; second, through the condenser; and third, through the outlet fitting to an **open trap drain**.



**IMPORTANT!** A backflow prevention device is required on the incoming water connection side. Please see the applicable national, state, and local codes for determining the proper configuration. Water pressure to the unit must not exceed 150 psi (1034 kPa).

### Electrical Connections

This equipment is supplied with a three-wire cord and grounding-type plug, for connection to a single-phase, 60-cycle, branch circuit supply. This unit must be plugged into a properly grounded receptacle. The cord and plug provided are 20A for 115/60/1 or 15A for 208-230/60/1; therefore, the wall outlet must also be 20A for 115/60/1 or 15A for 208- 230/60/1. Check the data label, located on the side panel, for electrical specifications. Permanent wiring may be employed, if required by local codes.

Instructions for conversion to permanent wiring are as follows:

1. Make sure the freezer is electrically disconnected.
2. Remove the appropriate panel and locate the small electrical box at the base of the freezer.
3. Remove the factory-installed cord and strain relief bushing.
4. Route incoming permanent wiring through the 7/8 in. (22 mm) hole in the base pan.
5. Connect two power supply leads. Attach the ground (earth) wire to the grounding lug inside the electrical box.
6. Make sure the unit is properly grounded before applying power.

In the United States, this equipment is intended to be installed in accordance with the National Electrical Code (NEC), ANSI/NFPA 70-1987. The purpose of the NEC code is the practical safeguarding of persons and property from hazards arising from the use of electricity. This code contains provisions considered necessary for safety. In all other areas of the world, equipment should be installed in accordance with the existing local codes. Contact your local authorities.



**FOLLOW YOUR LOCAL ELECTRICAL CODES.**

Each unit requires one power supply for each data label on the unit. Check the data label(s) on the freezer for branch circuit overcurrent protection or fuse, circuit ampacity, and other electrical specifications. See the wiring diagram provided inside the electrical box for proper power connections.



**WARNING!** This equipment must be properly grounded. Failure to do so can result in severe personal injury from electrical shock.



**IMPORTANT!** An equipotential grounding lug is provided with this unit. Some countries require the grounding lug to be properly attached to the rear of the frame by the authorized installer. The installation location is marked by the equipotential bonding symbol (5021 of IEC 60417-1) on both the removable panel and the unit's frame.



**IMPORTANT!**

- Stationary appliances which are not equipped with a power cord and a plug or another device to disconnect the appliance from the power source must have an all-pole disconnecting device with a contact gap of at least 0.125 in. (3 mm) installed in the external installation.
- Appliances that are permanently connected to fixed wiring and for which leakage currents may exceed 10 mA, particularly when disconnected or not used for long periods, or during initial installation, shall have protective devices to protect against the leakage of current, such as a GFI, installed by the authorized personnel to the local codes.
- Supply cords used with this unit shall be oil-resistant, sheathed flexible cable not lighter than ordinary polychloroprene or other equivalent synthetic elastomer-sheathed cord (code designation 60245 IEC 57) installed with the proper cord anchorage to relieve conductors from strain, including twisting, at the terminals and protect the insulation of the conductors from abrasion.

- If the supply cord is damaged, it must be replaced by an authorized Taylor service technician in order to avoid a hazard.
- Secure the supply cord ground lead to the machine in a location where if the cord is pulled, the main power leads will become taut before the ground lead can break loose.

## Beater Rotation



**NOTICE!** Beater rotation must be clockwise as viewed looking into the freezing cylinder.

To correct the rotation on a three-phase unit, interchange any two incoming power supply lines at the freezer main terminal block only. To correct rotation on a single-phase unit, exchange leads inside the beater motor. (Follow the diagram printed on the motor.)

Electrical connections are made directly to the terminal block provided in the main control box located behind the service panel.

It is recommended that beater rotation be performed by an authorized Taylor service technician.

### Refrigerant



**CAUTION!** This machine contains fluorinated greenhouse gases (F-Gas) to provide refrigeration using a hermetically sealed circuit or within foam insulation.

This machine's type of gas, quantity, Global Warming Potential (GWP), and CO<sub>2</sub> tonnes equivalent information is recorded on the machine's data label. The refrigerant used is generally considered nontoxic and nonflammable. However any gas under pressure is potentially hazardous and must be handled with caution.

**NEVER** fill any refrigerant cylinder completely with liquid. Filling the cylinder approximately 80% will allow for normal expansion.



**CAUTION!** Use only approved refrigerant listed on the machine's data-label or authorized through a manufacturer's technical bulletin. The use of any other refrigerant may expose users and operators to unexpected safety hazards.



**WARNING!** Refrigerant liquid sprayed onto the skin may cause serious damage to tissue. Keep eyes and skin protected. If refrigerant burns should occur, flush immediately with cold water. If burns are severe, apply ice packs and contact a physician immediately.



**NOTICE!** Taylor reminds technicians to be aware of and in compliance with local government laws regarding refrigerant recovery, recycling, and reclaiming systems. For information regarding applicable local laws, please contact your local authorized Taylor distributor.



**IMPORTANT!** *Refrigerants and their associated lubricants may be extremely moisture absorbent. When opening a refrigeration system, the maximum time the system is open must not exceed 15 minutes. Cap all open tubing to prevent humid air or water from being absorbed by the oil.*

The freezer you have purchased has been carefully engineered and manufactured to give you dependable operation. The Taylor Model 430 Torque, when properly operated and cared for, will produce a consistent quality product. Like all mechanical products, they require cleaning and maintenance. A minimum amount of care and attention is necessary if the operating procedures outlined in this manual are followed closely.



**IMPORTANT!** This manual should be read before operating or performing any maintenance on the unit.

Your Taylor unit will **NOT** compensate for and/or correct any errors made during the setup or filling operations. Thus, the initial assembly, setup, and priming procedures are of extreme importance. It is strongly recommended that all personnel responsible for the unit's operation, including assembly and disassembly, go through these procedures together in order to be properly trained and to make sure that all personnel understand their role in using and maintaining the unit.

If you require technical assistance, please contact your local authorized Taylor distributor.

**Note:** Your Taylor warranty is valid only if the parts are authorized Taylor parts, purchased from the local authorized Taylor distributor, and only if all required service work is provided by an authorized Taylor service technician. Taylor reserves the right to deny warranty claims on units or parts if Taylor unapproved parts or incorrect refrigerant were installed in the unit, system modifications were performed beyond factory recommendations, or it is determined that the failure was caused by abuse, misuse, neglect, or failure to follow all operating instructions. For full details of your Taylor warranty, see the Limited Warranty section in this manual.

Constant research results in steady improvements; therefore, information in this manual is subject to change without notice.



**IMPORTANT!** If the crossed-out wheeled-bin symbol is affixed to this unit, it signifies that this unit is compliant with the EU Directives as well as other similar end-of-life legislation in effect after August 13, 2005. Therefore, it must be collected separately after its use is completed and cannot be disposed as unsorted municipal waste.

The user is responsible for returning the unit to the appropriate collection facility, as specified by your local code.

For additional information regarding applicable local disposal laws, please contact the municipal waste facility and/or local authorized Taylor distributor.

### Compressor Warranty Disclaimer

2 The refrigeration compressor(s) on this unit are warranted for the term stated in the Limited Warranty section in this manual. However, due to the Montreal Protocol and the U.S. Clean Air Act Amendments of 1990, many new refrigerants are being tested and developed, thus seeking their way into the service industry. Some of these new refrigerants are being advertised as drop-in replacements for numerous applications. It should be noted that in the event of ordinary service to this unit's refrigeration system, **only the refrigerant specified on the affixed data label should be used.** The unauthorized use of alternate refrigerants will void your Taylor compressor warranty. It is the unit owner's responsibility to make this fact known to any technician he employs.

It should also be noted that Taylor does not warrant the refrigerant used in its equipment. For example, if the refrigerant is lost during the course of ordinary service to this machine, Taylor has no obligation to either supply or provide its replacement either at billable or nonbillable terms. Taylor does have the obligation to recommend a suitable replacement if the original refrigerant is banned, obsolete, or no longer available during the five (5) year warranty of the compressor.

Occasionally, Taylor may test new refrigerant alternates. Should a new refrigerant alternate prove, through Taylor's testing, that it would be accepted as a drop-in replacement for this unit, then the disclaimer in this "Compressor Warranty Disclaimer" section will not apply to the use of the alternate refrigerant approved by Taylor.

To find out the current status of an alternate refrigerant as it relates to your compressor warranty, call Taylor or your local authorized Taylor distributor. Be prepared to provide the model/serial number of the unit in question.

**Note:** *Continuing research results in steady improvements; therefore, information in this Operator Manual is subject to change without notice.*

We, at Taylor Company, are concerned about the safety of the operator at all times when they are coming in contact with the unit and its parts. Taylor makes every effort to design and manufacture built-in safety features to protect both operators and service technicians.

Installing and servicing refrigeration equipment can be hazardous due to system pressure and electrical components. Only trained and qualified service personnel should install, repair, or service refrigeration equipment. When working on refrigeration equipment, observe precautions noted in the literature, tags, and labels attached to the unit, and other safety precautions that may apply. Follow all safety code requirements. Wear safety glasses and work gloves.



**DANGER!** Failure to adhere to the following safety precautions may result in severe personal injury or death. Failure to comply with these warnings may also damage the unit and/or its components. Such damage may result in component replacement and service repair expenses.



**NOTICE! DO NOT** operate this machine without reading this entire manual first. Failure to follow all of these operating instructions may result in damage to the machine, poor performance, health hazards, or personal injury.



**IMPORTANT!** *This appliance is to be used only by trained personnel. It is not intended for use, cleaning, or maintenance by children or people with reduced physical, sensory, or mental capabilities or lack of experience and knowledge. Where limited equipment operation is allowed for public use, such as a self-serve application, supervision or instruction concerning the use of the appliance by a person responsible for their safety is required. Children should be supervised to ensure that they do not play with the appliance.*



**WARNING!** This machine must **NOT** be installed in an area where a water jet or hose can be used.

**NEVER** use a water jet or hose to rinse or clean the machine. Failure to follow this instruction may result in electrocution.



**WARNING!** Avoid injury.

- **DO NOT** operate the unit unless it is properly grounded.
- **DO NOT** operate the unit with larger fuses than specified on the unit's data label.
- All repairs should be performed by an authorized Taylor service technician.
- The main power supplies to the unit must be disconnected prior to performing installation, repairs, or maintenance.
- **For Cord-Connected Machines:** Only authorized Taylor service technicians or licensed electricians may install a plug or replacement cord on the machine.
- Units that are permanently connected to fixed wiring and for which leakage currents may exceed 10 mA, particularly when disconnected or not used for long periods, or during initial installation, shall have protective devices to protect against the leakage of current, such as a GFI, installed by the authorized personnel to the local codes.
- Stationary units which are not equipped with a power cord and a plug or another device to disconnect the appliance from the power source must have an all-pole disconnecting device with a contact gap of at least 0.125 in. (3 mm) installed in the external installation.
- Supply cords used with this unit shall be oil-resistant, sheathed flexible cable not lighter than ordinary polychloroprene or other equivalent synthetic elastomer-sheathed cord (code designation 60245 IEC 57) installed with the proper cord anchorage to relieve conductors from strain, including twisting, at the terminals and protect the insulation of the conductors from abrasion.
- If the supply cord is damaged, it must be replaced by an authorized Taylor service technician in order to avoid a hazard.

## SAFETY

- Secure the supply cord ground lead to the machine in a location where if the cord is pulled, the main power leads will become taut before the ground lead can break loose.

Failure to follow these instructions may result in electrocution. Contact your local authorized Taylor distributor for service.



**IMPORTANT!** An equipotential grounding lug is provided with this unit. Some countries require the grounding lug to be properly attached to the rear of the frame by the authorized installer. The installation location is marked by the equipotential bonding symbol (5021 of IEC 60417-1) on both the removable panel and the unit's frame.

3



**WARNING!** Avoid injury.

- **DO NOT** allow untrained personnel to operate this unit.
- **DO NOT** operate the unit unless all service panels and access doors are restrained with screws.
- **DO NOT** remove any internal operating parts (including, but not limited to, freezer door, beater, or scraper blades), unless all control switches are in the OFF position.

Failure to follow these instructions may result in severe personal injury, especially to fingers or hands, from hazardous moving parts.



**WARNING!** This unit has many sharp edges that can cause severe injuries.

- **DO NOT** put objects or fingers in the door spout. This may contaminate the product and cause severe personal injury from blade contact.
- **USE EXTREME CAUTION** when removing the beater assembly. The scraper blades are very sharp.



**CAUTION!** This machine must be placed on a level surface. Extreme care should be taken when

moving for any reason. Two or more persons are required to safely move this machine. Failure to comply may result in personal injury or damage to the machine.



**WARNING!** Only install this machine in a location where its use and maintenance is restricted to trained personnel. Failure to comply may result in personal injury.



**NOTICE!** Cleaning and sanitizing schedules are governed by your federal, state, or local regulatory agencies and must be followed accordingly. Please refer to the cleaning section of this manual for the proper procedure to clean this unit.

**Important!** This unit is designed to maintain product temperature under 41°F (5°C). Any product being added to this unit must be below 41°F (5°C). Failure to follow this instruction may result in health hazards and poor freezer performance.

**Do not** obstruct air intake and discharge openings.

Air-cooled units require a minimum of 3 in. (76.2 mm) of clearance around all sides of the freezer to allow for adequate air flow across the condenser. Failure to allow adequate clearance can reduce the refrigeration capacity of the freezer and possibly cause permanent damage to the compressor.

**For Indoor Use Only:** This unit is designed to operate indoors, under normal ambient temperatures of 70°F to 75°F (21°C to 24°C). The unit has successfully performed in high ambient temperatures of up to 104°F (40°C) at reduced capacities.

**Do not** run the unit without product. Failure to follow this instruction can result in damage to the unit.

**Noise Level:** Airborne noise emission does not exceed 78 dB(A) when measured at a distance of 1.0 meter from the surface of the machine and at a height of 1.6 meters from the floor.

## Exploded View

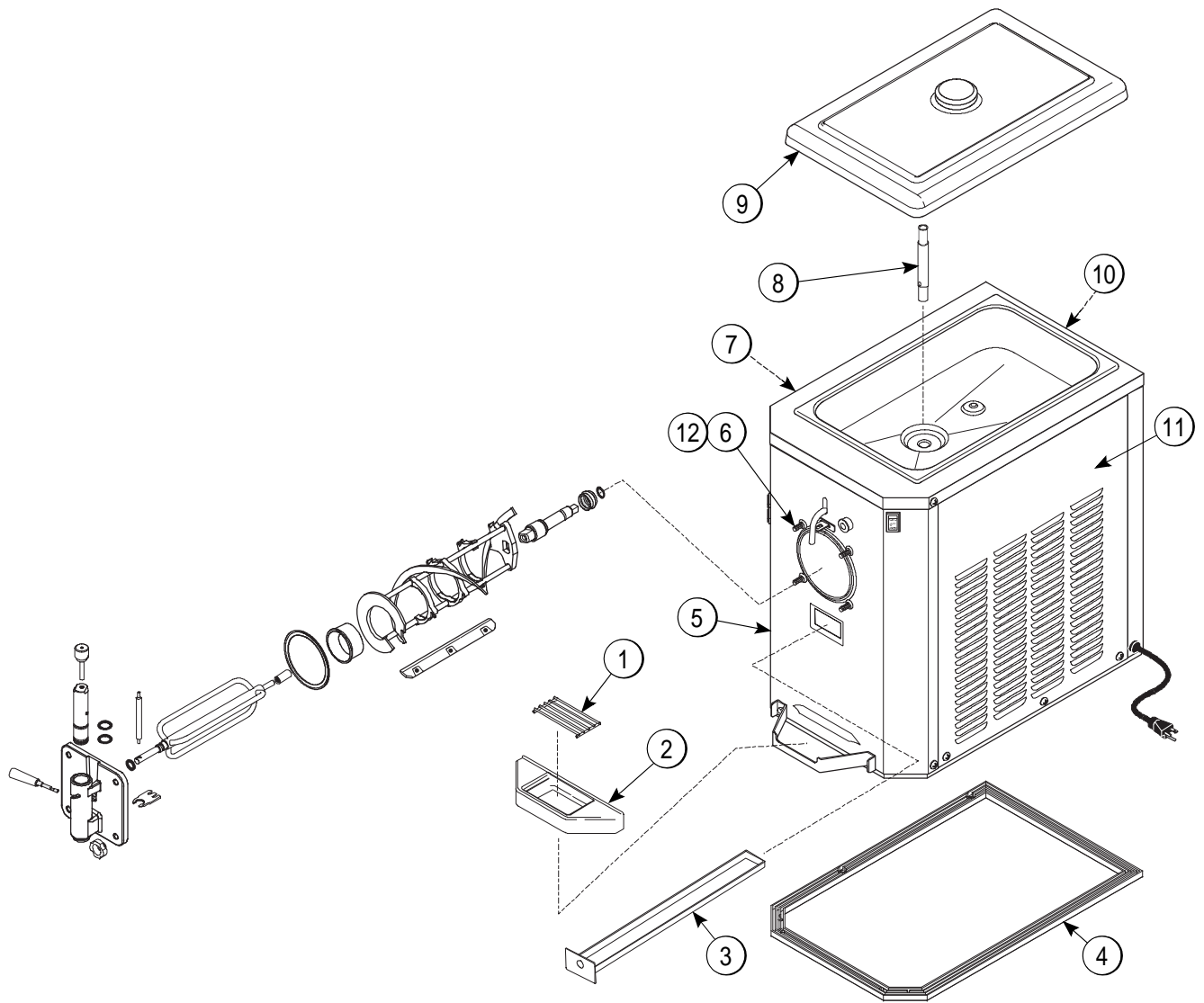

4

Figure 4-1

Item	Description	Part No.
1	Shield- Splash	049320
2	Tray- Drip	049319
3	Pan- Drip 17- 1/4" Long	027504
4	Gasket- Base Pan	049420
5	Panel- A.- Front	X50678
6	Stud- Nose Cone	013496

Item	Description	Part No.
7	Panel- Side L	049639
8	Tube- Feed- 13/32 Hole	025663- 10
9	Cover A.- Black INS	X49679- BLA
10	Panel- Rear	049325
11	Panel- Side R	049640
12	Washer- Freezer Stud	049032

Beater Door

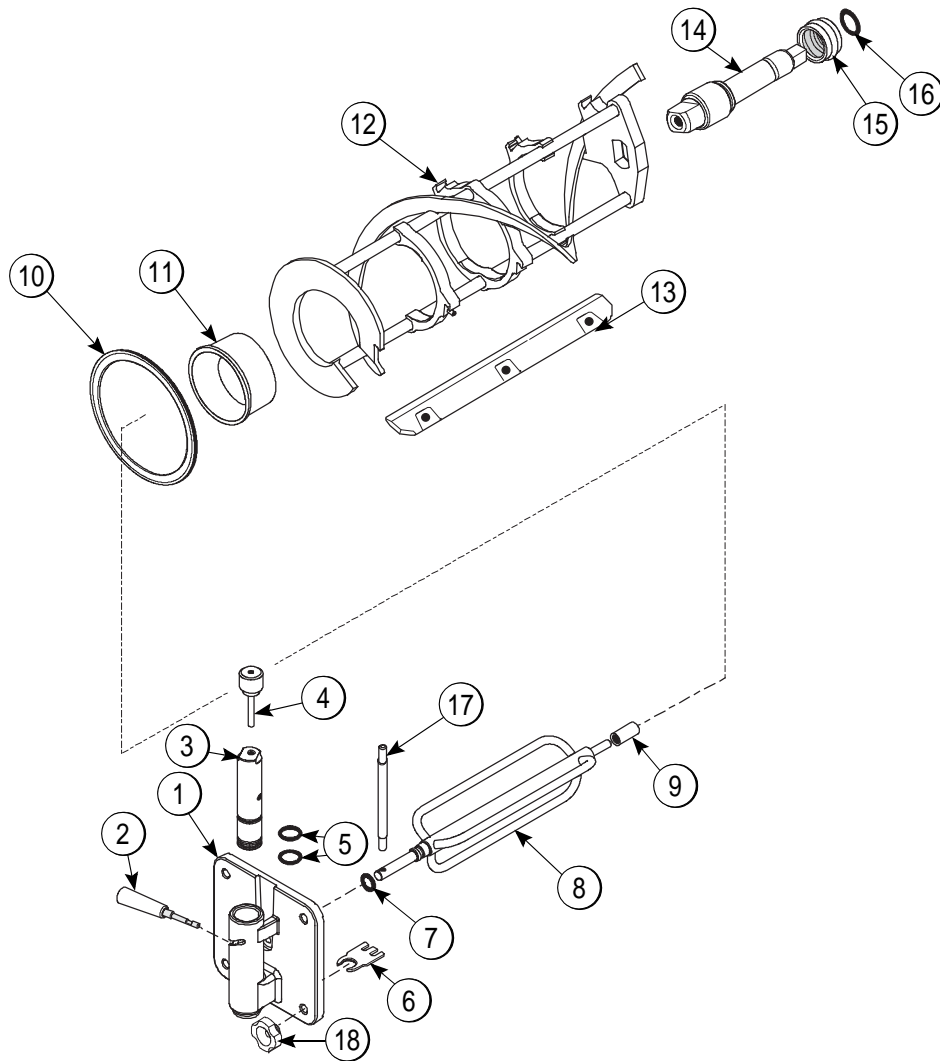

Figure 4-2

Item	Description	Part No.
1	Door A.- Slush- Partial	<a href="#">X83427SER3</a>
2	Handle A.- Draw- Slush	<a href="#">X47384</a>
3	Valve- Draw	047734
4	Pin A.- Valve Handle	<a href="#">X25929</a>
5	O-ring- 1 OD x .139 W	018550
6	Buster- Ice	047735
7	O-ring- .291 ID x .080 W	018550
8	Torque A. *430*	<a href="#">X50382</a>
9	Bearing- Guide	014496
10	Gasket- Door	014030
11	Bearing- Front	013116

Item	Description	Part No
12	Beater A.-7 qt.-1 Pin	<a href="#">X49490</a>
13	Blade-Scraper-Plastic 9-13/16L	084950
14	Shaft- Beater	035418
15	Seal- Drive Shaft	032560
16	O-ring- 7/8 OD x .139 W	025307
17	Arm- Torque	025660
18	Nut- Stud	029880

**Note:** Units equipped with prime plug doors, order Door A.- Slush- Partial

[X83427SER2](#), Plug- Prime 050405 & O-ring 043758. Not shown.

Accessories

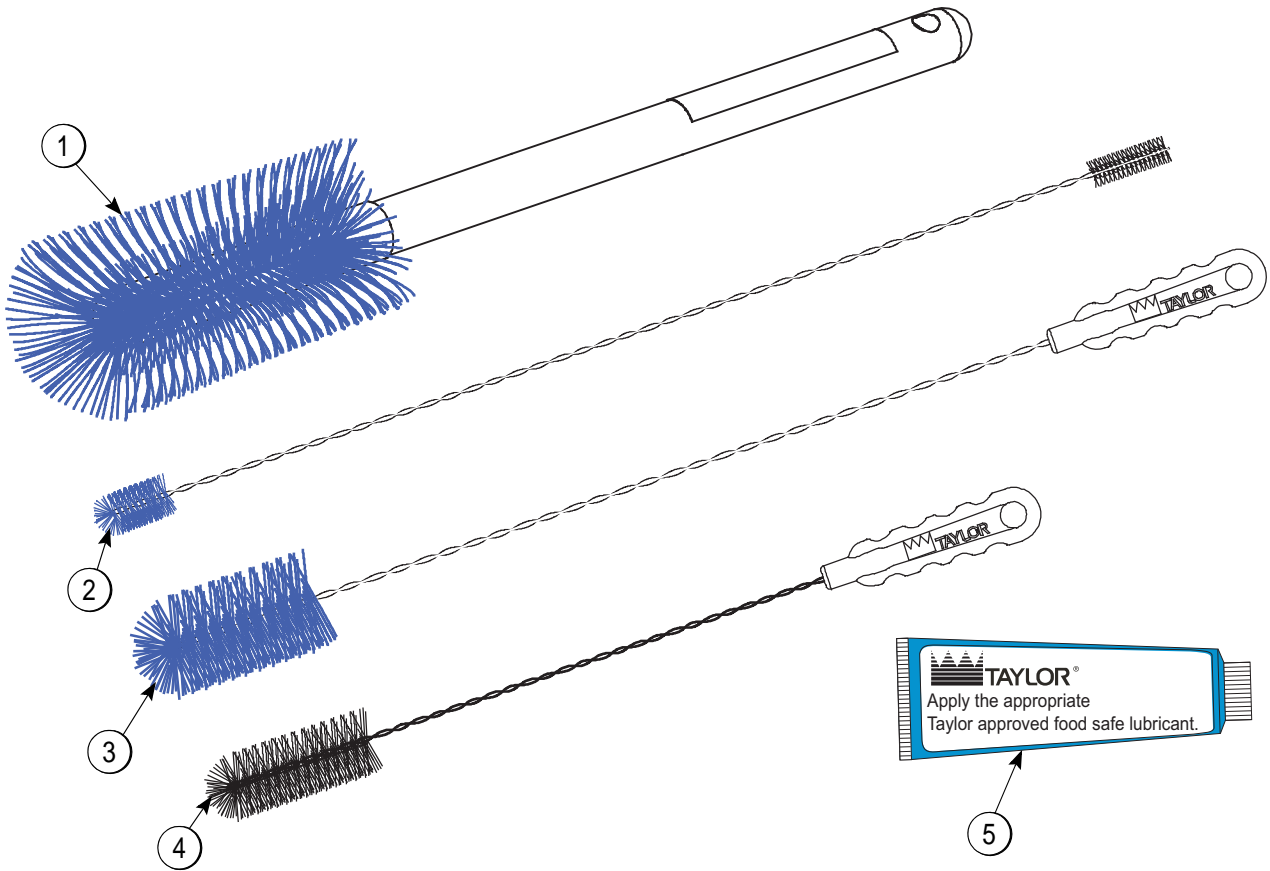

4

Figure 4-3

Item	Description	Part No.
1	Brush- Mix Pump Body- 3"X7"	023316
2	Brush- Double-Ended- Pump & Feed	013072
3	Brush- Draw Valve 1- 1/2"OD X 3"	014753
4	Brush- Rear Brg 1 in. x 2 in. x 14 in.	013071
5	Lubricant- Taylor 4 oz.	047518

Item	Description	Part No.
*6	Pail- 6 qt.	023348
*7	Kit A.- Tune Up *Slush*	X39969
*8	DVD- Ops Train Video 430	050987- DVD
**9	Sanitizer- Stera Sheen - Green	See Note

\* Not Shown

\*\* **Note:** A sample container of sanitizer is sent with the unit. For reorders, order Stera-Sheen® Part No. 055492 (100 2 oz. packs).



## Viscosity Adjustment

The viscosity (thickness) of the slush can be adjusted by turning the viscosity adjustment screw on the upper right side of the front panel. Turn the viscosity adjustment screw clockwise for a thicker product or counterclockwise for a thinner product. After making an adjustment, allow the refrigeration system to cycle two or three times to accurately evaluate the viscosity.

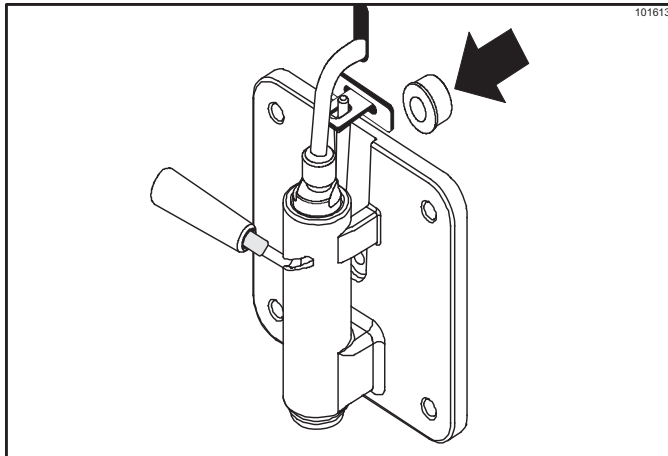

Figure 5-1

## Power Switch

The center position is off. The up position is AUTO, which activates the beater motor and the refrigeration system. The down position is WASH, which activates the beater motor only.

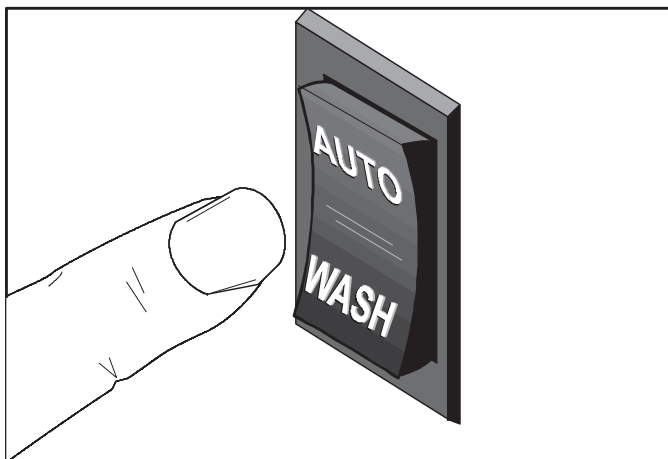

Figure 5-2

## Reset Button

The RESET button is located in the rear panel. The reset function protects the beater motor from an overload condition. If an overload occurs, the reset mechanism will trip. To properly reset the freezer, place the power switch in the Off position. Press the RESET button firmly. Place the power switch in the WASH position and observe the freezer's performance. Once satisfied, place the switch in the AUTO position.

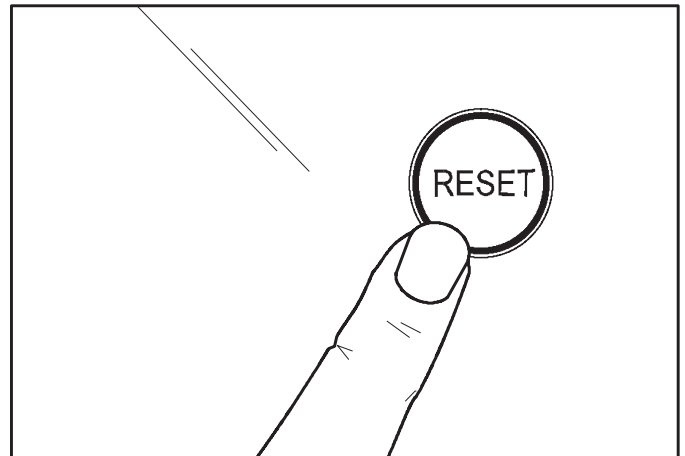

Figure 5-3

**Important!** Do not use metal objects to press the reset button.

## Indicator Lights

**MIX LOW**—When the MIX LOW light begins to flash, it indicates the mix tank has a low supply of mix and should be refilled as soon as possible.

**MIX OUT**—When the MIX LOW light is flashing, it indicates that the hopper is empty and the mix supply needs replenishing. To prevent damage to the unit, refrigeration discontinues automatically when the mix out indicator lights.



The Model 430 freezer is designed to produce shake or slush product at the desired thickness. This unit has a 4 qt (3.8 L) freezing cylinder.

We begin our instructions at the point where we enter the store in the morning and find the parts disassembled and laid out to air dry from the previous night's brush cleaning.

These opening procedures show you how to assemble these parts into the freezer, sanitize them, and prime the freezer with fresh mix in preparation to serve your first portion.

If you are disassembling the machine for the first time or need information to get to this starting point in our instructions, see "Disassembly" on page 6-8.

## Assembly

**Note:** When lubricating parts, use an approved food grade lubricant (for example, Taylor Lube).

1. Lubricate both grooves on the drive shaft and slide the O-ring in place.
2. Lubricate the O-ring and shaft portion that comes in contact with the bearing. **Do not** lubricate the square end of the drive shaft.
3. Lubricate the boot seal groove and slide the boot seal over the shaft and groove until it snaps into place.
4. Fill the inside portion of the seal with 1/4 in. more lubricant and evenly lubricate the end of the seal that fits onto the rear shell bearing. Install the drive shaft.

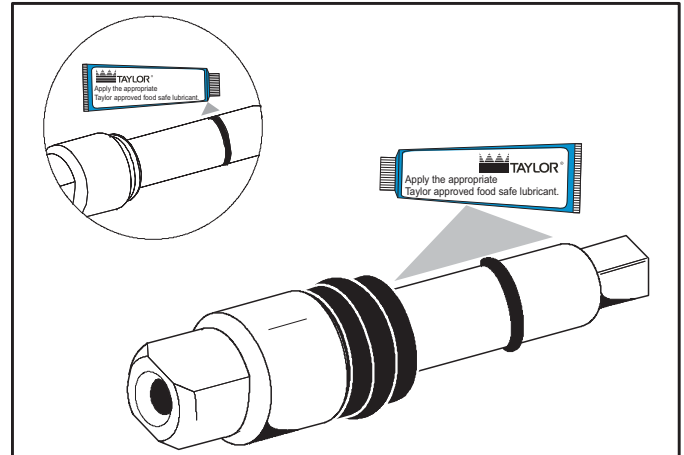

Figure 6-1

**Note:** Do not install the boot seal inside out.

5. Insert the beater drive shaft into the rear shell bearing and engage the square end firmly into the female socket of the drive unit. Make sure that the drive shaft fits into the drive coupling without binding.

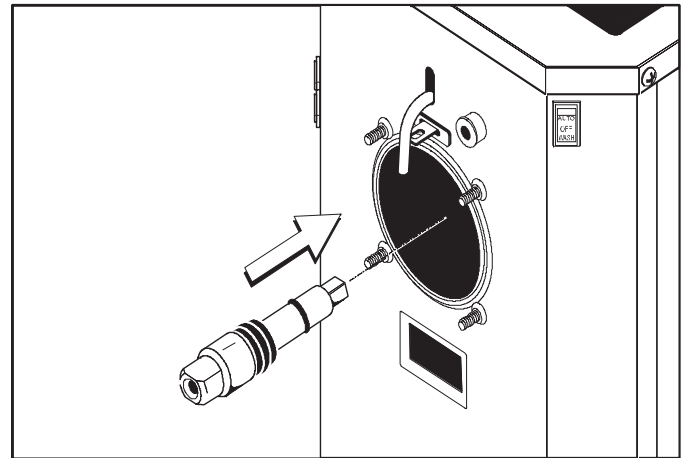

Figure 6-2



**WARNING!** Use extreme caution when handling the beater assembly. The scraper blades are very sharp and may cause injury.

6. Before installing the beater assembly, check the scraper blades for any signs of wear or damage. If a scraper blade is nicked or worn, replace both blades.

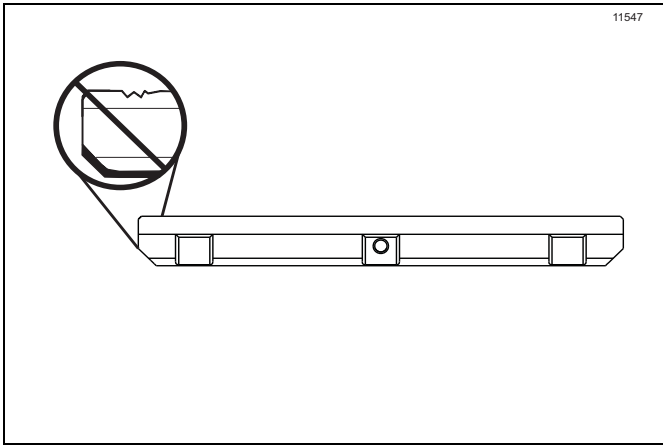

Figure 6-3

7. If the blade is in good condition, place the blade on the beater assembly. Make sure the holes in the blade are securely positioned over the beater pin.

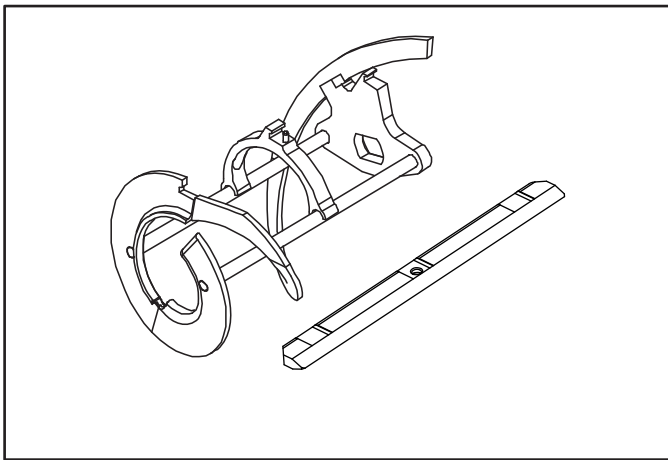

Figure 6-4

8. Holding the beater securely, slide the beater into the freezing cylinder, and align the hole at the rear of the beater with the flats on the end of the drive shaft.
9. Slide the beater the remainder of the way into the freezing cylinder and over the end of the drive shaft. The beater assembly will not protrude beyond the front of the freezing cylinder.

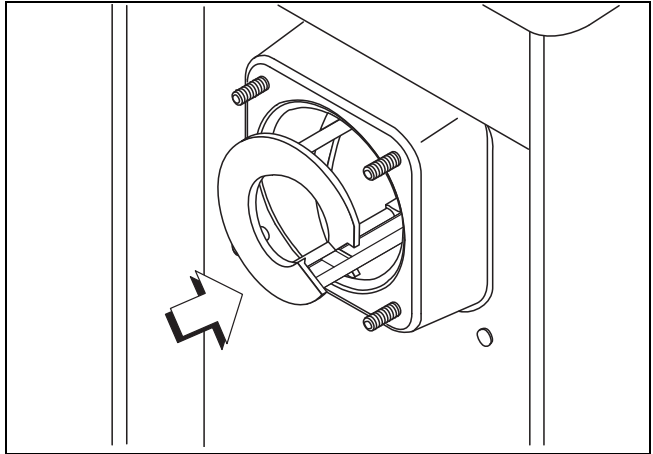

Figure 6-5

10. Install the white plastic guide bearing on the short end of the torque rotor.
11. Slide the O-ring into the groove on the long end of the torque rotor and lubricate the O-ring. **Do not** lubricate the guide bearing.

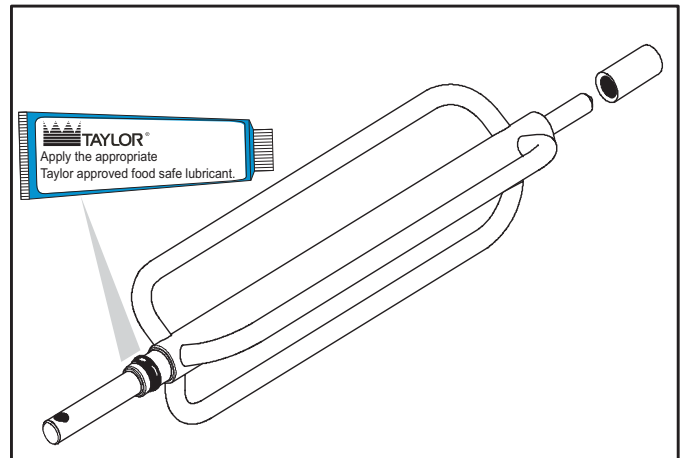

Figure 6-6

12. Insert the torque rotor end with the guide bearing into the pilot hole in the center of the drive shaft. The hole in the torque rotor shaft should be rotated to the 12 o'clock position.

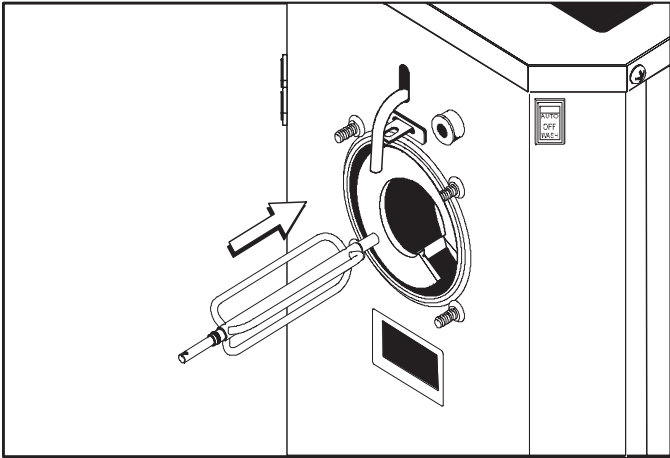

Figure 6-7

13. Before assembling the freezer door, check the following for any nicks, cracks, or signs of wear: front bearing, door gasket, draw valve, O-rings, and all sides of the door assembly, including the inside of the draw valve bore.

14. Replace any damaged parts.

15. Assemble the freezer door with the ice buster (door spout clearing device). To assemble the door with the ice buster, install the O-rings on the draw valve and lubricate.

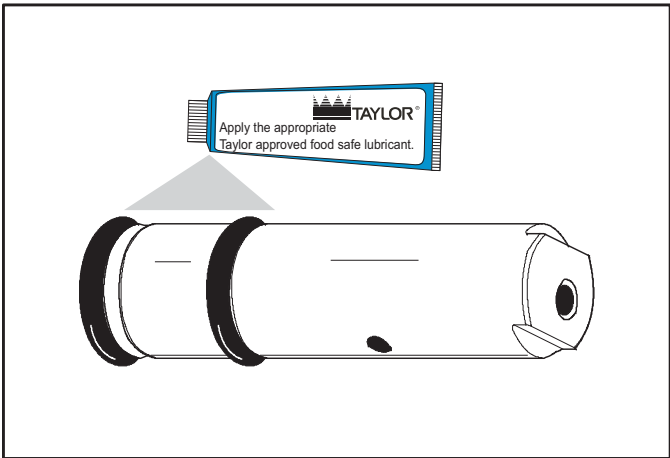

Figure 6-8

16. Insert the draw valve into the door, leaving approximately 1/2 in. of the valve sticking out the top of the door.

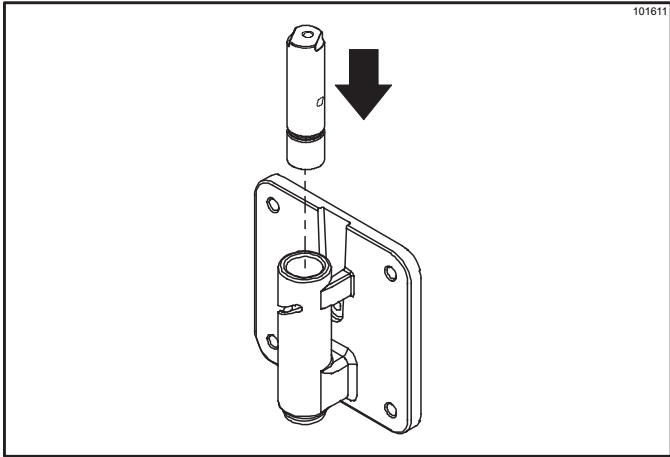

Figure 6-9

17. Rotate the draw valve so the flats on the top of the draw valve are perpendicular to the door face.

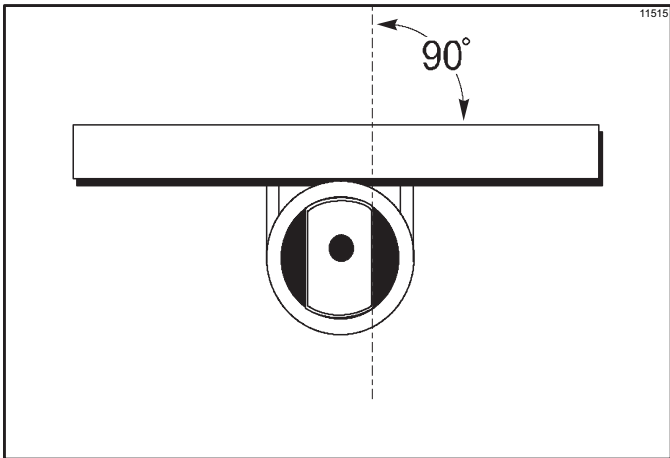

Figure 6-10

18. Insert the ice buster through the door spout and into the slot located just above the lower O-ring.

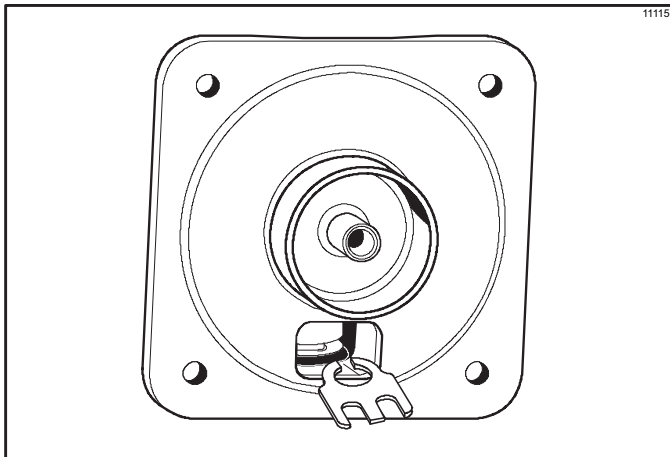

Figure 6-11

## OPERATING PROCEDURES

19. With the ice buster in place, rotate the draw valve to allow installation of the draw handle. This will lock the ice buster in place. Install the draw handle pin, and close the draw valve by moving the handle to the left.

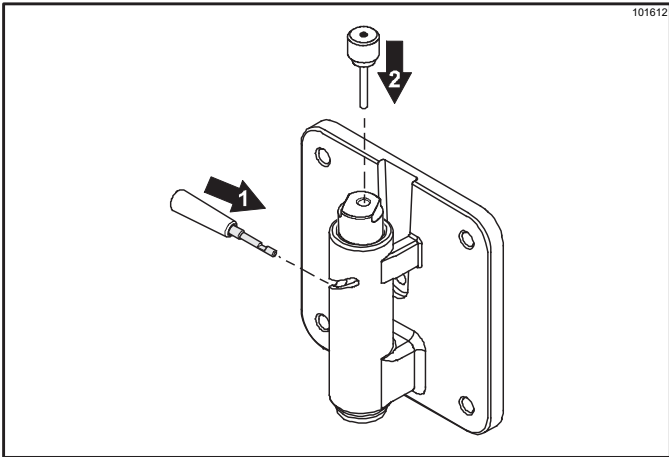

Figure 6-12

20. Place the large rubber gasket into the groove on the back side of the freezer door. Slide the white, plastic front bearing onto the bearing hub, making certain that the flanged end of the bearing is resting against the freezer door. **Do not** lubricate the door gasket or front bearing.

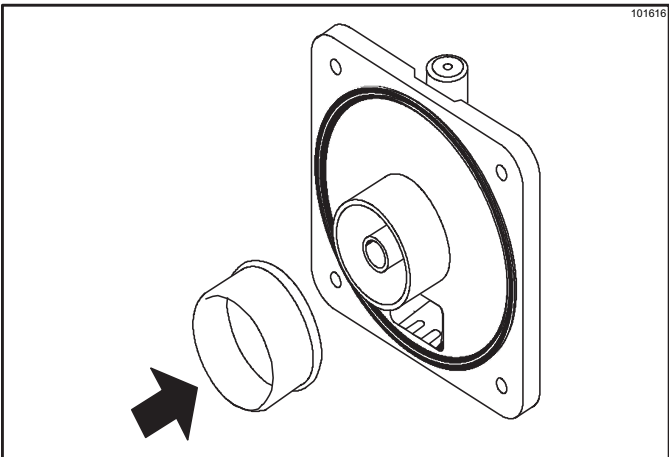

Figure 6-13

21. Position the torque arm by inserting it through the slot in the torque switch arm and down into the hole in the torque rotor which protrudes from the door. Verify proper installation by moving the torque rotor back and forth to be sure it moves freely and easily.

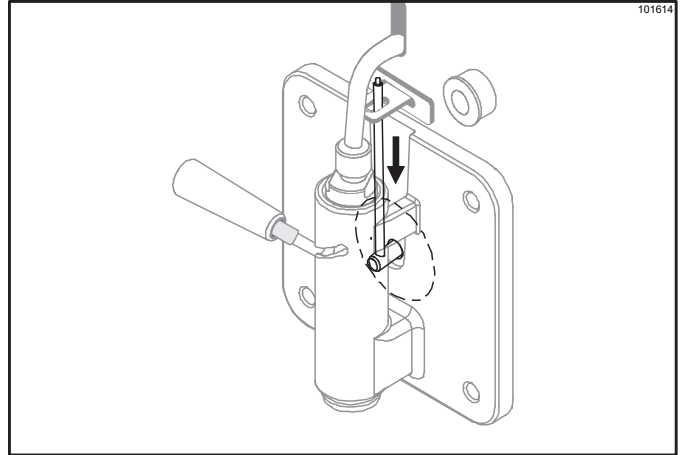

Figure 6-14

22. Install the front drip pan. Slide the long drip pan into the hole in the front panel.

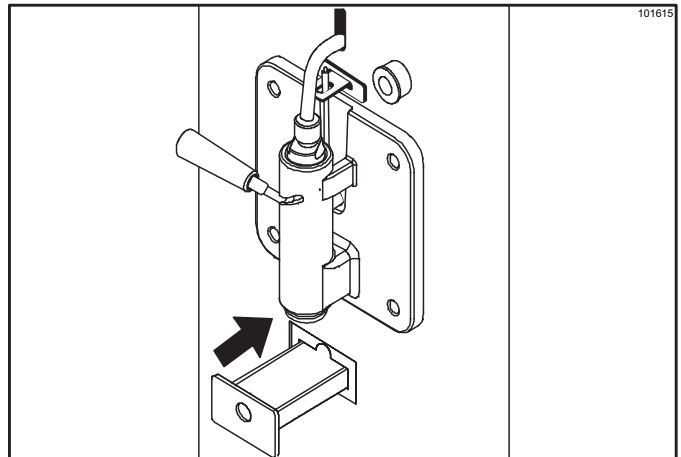

Figure 6-15

23. Install the front drip tray and splash shield beneath the door spout.

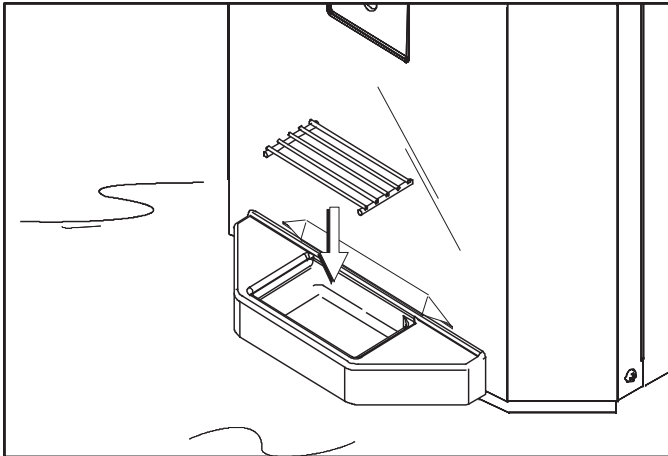

Figure 6-16

24. Lay the air/mix feed tube (optional) in the bottom of the mix hopper.

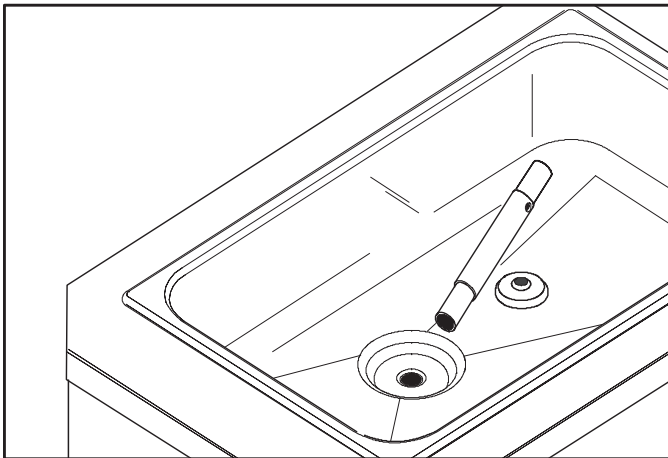

Figure 6-17

## Sanitizing

1. Prepare a pail of an approved 100 PPM sanitizing solution (for example, 2 gal. [7.6 L] of Stera-Sheen®).

**Note:** Use warm water and following the manufacturer's specifications.

2. Pour the sanitizing solution into the hopper and allow the solution to flow into the freezing cylinder.

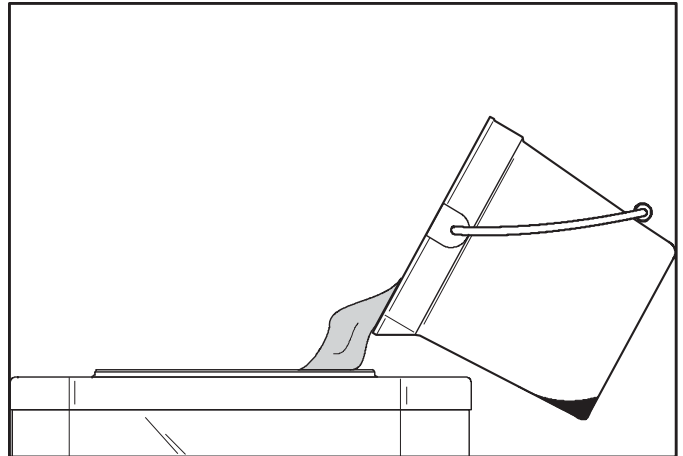

Figure 6-18

3. While the solution is flowing into the freezing cylinder, brush clean the mix hopper, air/mix feed tube (optional), and mix inlet hole.
4. Place the power switch in the WASH position. This action agitates the sanitizing solution in the freezing cylinder.
5. Allow the solution to agitate for five minutes.

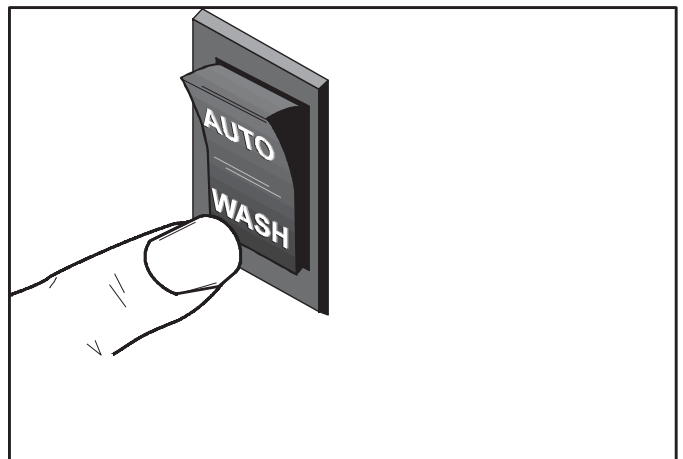

Figure 6-19

## OPERATING PROCEDURES

6. Place an empty pail beneath the door spout and move the draw handle to the right.
7. Draw off all the sanitizing solution. When the sanitizer stops flowing from the door spout, move the draw handle to the left and place the control switch in the off (center) position.

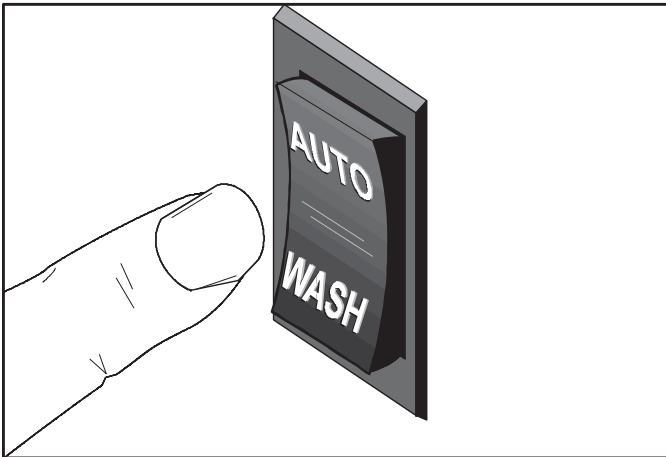

Figure 6-20

**Important!** The unit must **not** be placed in Auto mode until all sanitizing solution is removed from the freezing cylinder and proper priming procedures have been completed. Failure to follow this instruction may result in damage to the freezing cylinder.

8. **Optional:** Using sanitized hands, stand the air/mix feed tube in the corner of the hopper.

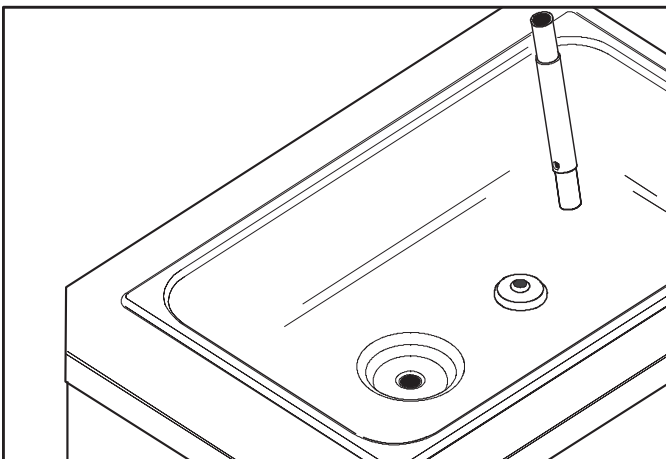

Figure 6-21

## Priming

1. With a pail beneath the door spout, move the draw handle to the right.
2. Pour 2 gal. (7.6 L) of **fresh** mix into the hopper and allow the mix to flow into the freezing cylinder. This forces out any remaining sanitizing solution.
3. When full-strength mix is flowing from the door spout, move the draw handle to the left.

**Important!** Failure to remove all sanitizing solution may result in damage to the freezing cylinder.

4. **Optional:** When the mix has stopped bubbling down into the freezing cylinder, install the air/mix feed tube in the mix inlet hole with the hole side down.

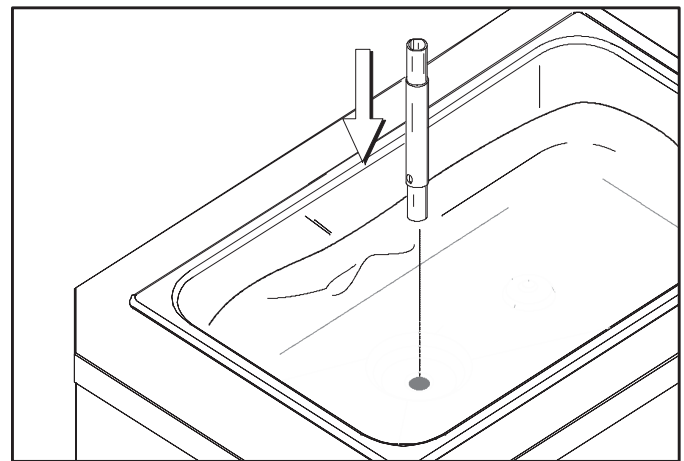

Figure 6-22

- Place the power switch in the AUTO position.

When the unit cycles off, the product is at serving viscosity (thickness). The viscosity of the slush can be adjusted by turning the viscosity adjustment screw on the upper right of the front panel.

- Turn the viscosity adjustment screw clockwise for a thicker product or counterclockwise for a thinner product.

After making an adjustment, allow the refrigeration system to cycle two or three times to accurately evaluate the viscosity.

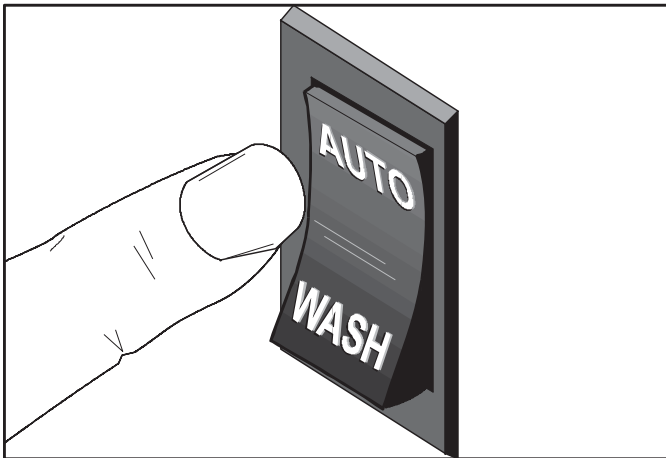

Figure 6-23

- Place the mix hopper cover in position. Periodically, during the day's operation, check to be sure there is a sufficient amount of mix in the hopper.

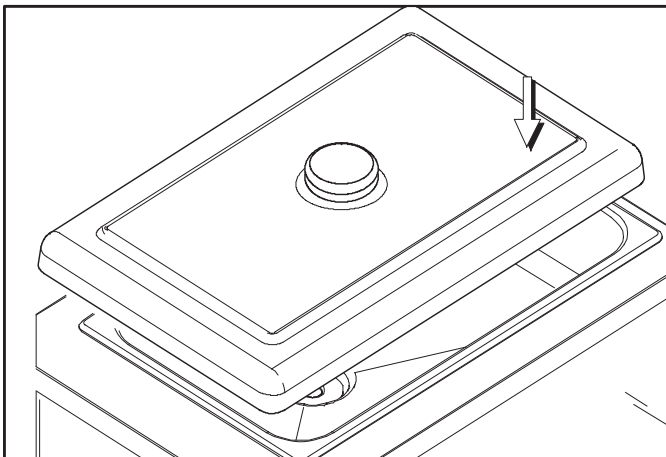

Figure 6-24

## Closing Procedures

To disassemble this unit, the following items are needed:

- Two cleaning pails
- Necessary brushes (provided with freezer)
- Cleaner
- Single-service towels

## Draining Product from the Freezing Cylinder

- Place the control switch in the off position as far ahead of cleaning time as possible to allow frozen product to soften for easier cleaning.
- Raise the hopper cover. If the unit is equipped with an air/mix feed tube, take it to the sink for cleaning.
- If local health codes permit the use of rerun, place a sanitized, NSF-approved stainless steel rerun container beneath the door spout. Place the power switch in the WASH position and move the draw handle to the right. When all the product stops flowing from the door spout, move the draw handle to the left and place the power switch in the off position. Place the sanitized lid on the rerun container and place it in the walk-in cooler.

**Note:** For additional information regarding the proper use of rerun, see "Priming" on page 6-6.

- If local health codes **do not** permit the use of rerun, the product must be discarded. Follow the instructions in the previous step, except drain the product into a pail and properly discard the mix.



### Rinsing

1. Pour 2 gal. (7.6 L) of cool, clean water into the mix hopper. With the brushes provided, scrub the mix hopper and the mix inlet hole.

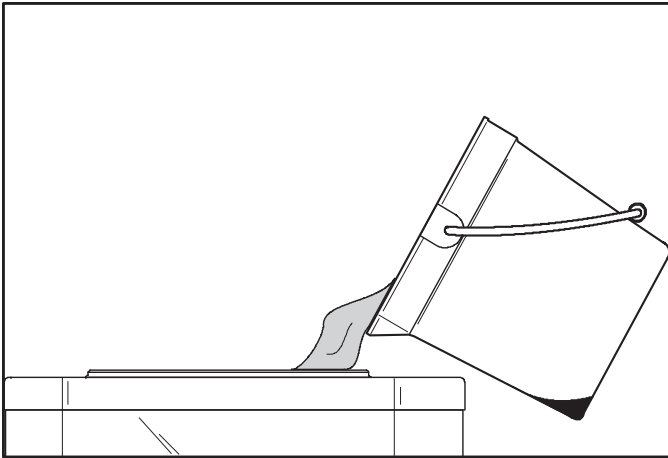

Figure 6-25

2. With a pail beneath the door spout, place the power switch in the WASH position and move the draw handle to the right.
3. Drain all the rinse water from the freezing cylinder.
4. When the rinse water stops flowing from the door spout, move the draw handle to the left and place the control switch in the off position.
5. Repeat this procedure until the rinse water being drawn from the freezing cylinder is clear.

6

### Cleaning

1. Prepare an approved 100 PPM cleaning solution (for example, 2 gal. [7.6 L] of Stera-Sheen®).

**Note:** Use warm water and following the manufacturer's specifications.

2. Pour the cleaning solution into the hopper and allow it to flow into the freezing cylinder.
3. While the solution is flowing into the freezing cylinder, brush clean the mix hopper and mix inlet hole.
4. Place the control switch in the WASH position. This agitates the cleaning solution in the freezing cylinder.
5. Place an empty pail beneath the door spout and move the draw handle to the right. Draw off all of the cleaning solution. When the solution stops flowing from the door spout, move the draw handle to the left, and place the power switch in the off position.

### Disassembly

1. Make sure the control switch is in the off position.
2. Remove the handscrews, freezer door, beater assembly, torque rotor, scraper blade, and drive shaft from the freezing cylinder. Take these parts to the sink for cleaning.
3. Remove the front-drip tray and splash shield. Take these parts to the sink for cleaning.
4. Remove the rear drip pan from the front panel.

**Note:** If the drip pan is filled with an excessive amount of mix, the drive shaft seal should be replaced or properly lubricated.

## Brush Cleaning

1. Prepare a sink with a cleaning solution (for example, Stera-Sheen®).

**Note:** Use warm water and following the manufacturer's specifications.

**Important!** Follow label directions, since too **strong** of a solution can cause parts damage, while too **mild** of a solution will not provide adequate cleaning. Make sure all brushes provided with the freezer are available for brush cleaning.

2. Remove the O-ring and seal from the drive shaft and remove the bearing from the torque rotor.
3. Remove the draw valve, ice buster, front bearing, and gasket from the freezer door. Remove all O-rings.

**Note:** To remove O-rings, use a single-service towel to grasp the O-ring. Apply pressure in an upward direction until the O-ring pops out of its groove. With the other hand, push the top of the O-ring forward until it rolls out of the groove and can be removed easily.

4. Thoroughly brush-clean all disassembled parts in the cleaning solution, making sure all lubricant and mix film is removed. Place all the cleaned parts on a clean, dry surface to air dry.
5. Return to the freezer with a small amount of cleaning solution. Brush-clean the rear shell bearing at the back of the freezing cylinder with the black bristle brush.

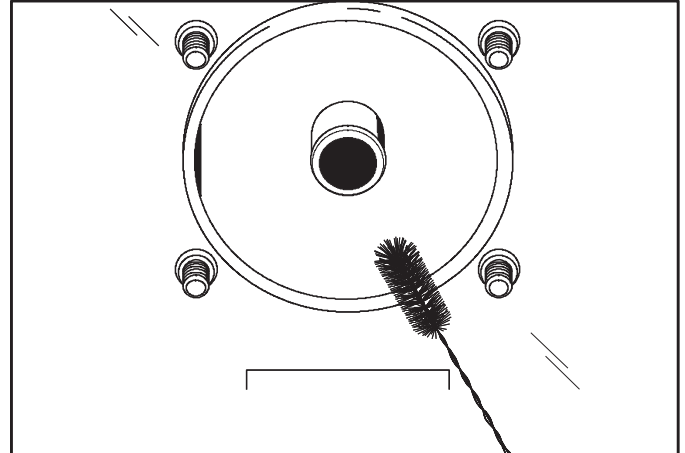

Figure 6-26

6. Wipe clean all exterior surfaces of the freezer.



## During Cleaning and Sanitizing



**ALWAYS FOLLOW LOCAL HEALTH CODES.**

Cleaning and sanitizing schedules are governed by federal, state, or local regulatory agencies, and must be followed accordingly. If the unit has a Standby mode, it must not be used in lieu of proper cleaning and sanitizing procedures and frequencies set forth by the ruling health authority. The following check points should be stressed during the cleaning and sanitizing operations.

## Troubleshooting Bacterial Count

- Thoroughly clean and sanitize the machine regularly, including complete disassembly and brush cleaning.
  - Use all brushes supplied for thorough cleaning. The brushes are specially designed to reach all mix passageways.
  - Use the white bristle brush to clean the mix inlet hole, which extends from the mix hopper down to the rear of the freezing cylinder.
  - Use a screwdriver and cloth towel to keep the female hex drive socket and rear shell bearing clean and free of lubricant and mix deposits.
  - Use the black bristle brush to thoroughly clean the rear shell bearing located at the rear of the freezing cylinder. Make sure there is a generous amount of cleaning solution on the brush.
  - If local health codes permit the use of rerun, make sure the mix rerun is stored in a sanitized, covered stainless steel container and used the following day. **Do not** prime the machine with rerun. When using rerun, skim off the foam and discard, then mix the rerun with fresh mix in a ratio of 50/50 during the day's operation.
  - On a designated day of the week, run the mix as low as feasible and discard after closing. This will break the rerun cycle and reduce the possibility of high bacteria and coliform counts.
- Properly prepare the cleaning and sanitizing solutions. Read and follow label directions carefully. Too **strong** of a solution may damage the parts, and too **weak** of a solution will **not** adequately clean or sanitize.
  - The temperature of mix in the mix hopper and walk-in cooler should be below 40°F (4.4°C).

## Regular Maintenance Checks

- Replace scraper blades that are nicked, damaged or worn down. Before installing the beater, be certain the scraper blade is properly attached.
- Check the rear shell bearing for signs of wear (excessive mix leakage in rear-drip pan) and make sure it is properly cleaned.
- Using a screwdriver and cloth towel, keep the rear shell bearing and the female square drive socket clean and free of lubricant and mix deposits.
- Dispose of O-rings and seals if they are worn, torn, or fit too loosely, and replace them with new ones.
- Dispose of seals if they are worn, torn, or fit too loosely, and replace them with new ones.
- Follow all lubricating procedures described in "Assembly" on page 6-1.
- Replace scraper blades that are damaged or nicked. Before installing the beater assembly, make sure that scraper blades are properly attached to the beater assembly.
- Check the condenser(s) for accumulation of dirt and lint. Dirty condensers reduce the efficiency and capacity of the machine. Condensers should be cleaned **monthly** with a soft brush. **Never** use screwdrivers or other metal probes to clean between the fins.

**Note:** For machines equipped with an air filter, it will be necessary to vacuum the filters on a monthly schedule.

### Winter Storage

If the place of business is to be closed during the winter months, it is important to protect the freezer by following certain precautions, particularly if the building is to be left unheated and subject to freezing conditions.

Disconnect the unit from the main power source to prevent possible electrical damage.

Your local Taylor distributor can perform this service for you.

Wrap detachable parts of the unit such as beater and blades, drive shaft, and freezer door, and place them in a protected dry place. Rubber trim parts and gaskets can be protected by wrapping them with moisture-proof paper. All parts should be thoroughly cleaned of dried mix or lubrication accumulations, which attract mice and other vermin.

On water-cooled units, disconnect the water supply. Relieve pressure on the spring in water valve. Use air pressure on the outlet side to blow out any remaining water in the condenser. **This is extremely important.** Failure to follow this procedure may cause severe and costly damage to the refrigeration system.

Problem	Probable Cause	Remedy	Page Ref.
1. No product being dispensed.	a. Power switch is in the off position.	a. Place power switch in the AUTO position.	6-6
	b. Improper mixing of product	b. Carefully follow directions for mixing product.	---
	c. Inadequate mix in hopper	c. Fill the hopper with mix.	6-6
	d. Product frozen in freezing cylinder.	d. Adjust viscosity adjustment accordingly.	5-1
	e. Unit out on reset	e. Place power switch in the off position. Press the reset button. Return control switch to the AUTO position.	5-1
	f. Beater assembly is not rotating at all or counterclockwise. Control switch is not in the AUTO position.	f. The power switch must be in the AUTO position. If beater is rotating counterclockwise, call service technician to correct rotation.	1-1
	g. Unit is unplugged.	g. Plug in the power cord.	---
	h. Tripped circuit breaker or blown fuse.	h. Reset the circuit breaker or replace the fuse.	---
2. Unit does not operate in the Auto or Wash mode.	a. Unit unplugged at wall receptacle.	a. Plug in the power cord.	---
	b. Tripped circuit breaker or blown fuse.	b. Reset the circuit breaker or replace the fuse.	---
	c. Unit out on reset	c. Turn the power switch off. Press the reset button. Return the control switch to the AUTO position.	5-1
3. No compressor operation in the Auto mode.	a. Beater motor is out on overload.	a. Turn the power switch off. Press the RESET button. Return the power switch to the AUTO position.	5-1
	b. Condenser dirty A/C	b. Clean the condenser monthly.	7-1
4. Product too thick.	a. Inadequate mix in hopper	a. Fill the hopper with mix.	6-6
	b. Improper mixing of product	b. Carefully follow the directions for mixing product.	---
	c. The viscosity adjustment is set incorrectly.	c. Place unit in the Auto mode only after priming is complete and all sanitizing solution is removed.	5-1
	d. The torque arm is not installed.	d. Install the torque arm.	6-4
5. Product too thin.	a. Missing, incorrectly installed, or bad scraper blade	a. Install or replace the scraper blade.	6-1
	b. Improper mixing of product	b. Carefully follow directions for mixing product.	---
	c. The viscosity adjustment is set incorrectly.	c. Adjust accordingly.	5-1
	d. Incorrect beater rotation	d. Contact a service technician.	---
	e. Dirty condensers	e. Clean regularly.	7-1

## TROUBLESHOOTING

Problem	Probable Cause	Remedy	Page Ref.
6. The freezing cylinder walls are scored.	a. Scraper blades are damaged.	a. Replace the scraper blades.	6-1
	b. Missing or worn front bearing on freezer door.	b. Install or replace the front bearing.	6-4
	c. Unit was placed in Auto mode before all sanitizing solution was removed from freezing cylinder.	c. Place unit in the Auto mode after priming is complete and all sanitizing solution has been removed.	6-5/6-6
	d. The beater assembly is bent/damaged.	d. Call a service technician to repair or replace.	---
7. Excessive leakage into rear drip pan.	a. Improper or inadequate lubrication of drive shaft seal	a. Use correct lubricant (Taylor Lube) and follow lubrication procedures.	6-1
	b. Bad or missing seal on drive shaft.	b. Replace seal every three months.	9-1
	c. Worn rear shell bearing.	c. Contact service technician for replacement.	---
8. Excessive leakage from door spout.	a. Improper or inadequate lubrication of draw valve O-rings.	a. Use correct lubricant (Taylor Lube) and follow lubrication procedures.	6-1
	b. Bad or missing O-rings on draw valve.	b. Replace O-rings every three months.	9-1
9. Unable to remove drive shaft.	a. Lubrication on square end of drive shaft.	a. Do not lubricate square end. Contact a service technician for replacement.	6-1
	b. Rounded corners of drive shaft, drive coupling, or both.	b. Contact service technician to replace drive shaft, drive coupling, or both.	---

Table 9-1

Part Description	Every 3 Months	Every 6 Months	Annually	Quantities To Be Replaced
Drive Shaft Seal	X			1
Drive Shaft O-ring	X			1
Scraper Blade	X			1
Freezer Door Gasket	X			1
Front Bearing	X			1
Draw Valve O-rings	X			2
Black Bristle Brush - 1" x 2"		Inspect and replace if necessary.	Maximum	1
White Bristle Brush -1- 1/2" x 2"		Inspect and replace if necessary.	Maximum	1
White Bristle Brush - 3" x 7"		Inspect and replace if necessary.	Maximum	1



## TAYLOR COMPANY LIMITED WARRANTY ON FREEZERS

Taylor Company is pleased to provide this limited warranty on new Taylor-branded freezer equipment available from Taylor to the market generally (the "Product") to the original purchaser only.

### LIMITED WARRANTY

Taylor warrants the Product against failure due to defect in materials or workmanship under normal use and service as follows. All warranty periods begin on the date of original Product installation. If a part fails due to defect during the applicable warranty period, Taylor, through an authorized Taylor distributor or service agency, will provide a new or re-manufactured part, at Taylor's option, to replace the failed defective part at no charge for the part. Except as otherwise stated herein, these are Taylor's exclusive obligations under this limited warranty for a Product failure. This limited warranty is subject to all provisions, conditions, limitations and exclusions listed below and on the reverse (if any) of this document.

Table 10-1

Product	Part	Limited Warranty Period
Soft Serve	Insulated Shell Assembly	Five (5) Years
Frozen Yogurt Shakes	Refrigeration Compressor (except service valve)	Five (5) Years
Smoothies	Beater Motors	Two (2) Years
Frozen Beverage	Beater Drive Gear	Two (2) Years
Batch Desserts	Printed circuit boards and Softech controls beginning with serial number H8024200	Two (2) Years
	Parts Not Otherwise Listed in This Table or Excluded Below	One (1) Years

### LIMITED WARRANTY CONDITIONS

1. If the date of original installation of the Product cannot be verified, then the limited warranty period begins ninety (90) days from the date of Product manufacture (as indicated by the Product serial number). Proof of purchase may be required at time of service.
2. This limited warranty is valid only if the Product is installed and all required service work on the Product is performed by an authorized Taylor distributor or service agency, and only if genuine, new Taylor parts are used.
3. Installation, use, care, and maintenance must be normal and in accordance with all instructions contained in the Taylor Operator's Manual.
4. Defective parts must be returned to the authorized Taylor distributor or service agency for credit.
5. The use of any refrigerant other than that specified on the Product's data label will void this limited warranty.

### LIMITED WARRANTY EXCEPTIONS

This limited warranty does **not** cover:

1. Labor or other costs incurred for diagnosing, repairing, removing, installing, shipping, servicing, or handling of defective parts, replacement parts, or new Products.

## LIMITED WARRANTY ON EQUIPMENT

---

2. Normal maintenance, cleaning, and lubrication as outlined in the Taylor Operator's Manual, including cleaning of condensers.
3. Replacement of wear items designated as Class "000" parts in the Taylor Operator's Manual.
4. External hoses, electrical power supplies, and machine grounding.
5. Parts not supplied or designated by Taylor, or damages resulting from their use.
6. Return trips or waiting time required because a service technician is prevented from beginning warranty service work promptly upon arrival.
7. Failure, damage or repairs due to faulty installation, misapplication, abuse, no or improper servicing, unauthorized alteration or improper operation or use as indicated in the Taylor Operator's Manual, including but not limited to the failure to use proper assembly and cleaning techniques, tools, or approved cleaning supplies.
8. Failure, damage, or repairs due to theft, vandalism, wind, rain, flood, high water, water, lightning, earthquake, or any other natural disaster, fire, corrosive environments, insect or rodent infestation, or other casualty, accident, or condition beyond the reasonable control of Taylor; operation above or below the electrical or water supply specification of the Product; components repaired or altered in any way so as to, in the judgment of the Manufacturer, adversely affect performance, or normal wear or deterioration.
9. Any Product purchased over the Internet.
10. Failure to start due to voltage conditions, blown fuses, open circuit breakers, or damages due to the inadequacy or interruption of electrical service.
11. Electricity or fuel costs, or increases in electricity or fuel costs for any reason whatsoever.
12. Damages resulting from the use of any refrigerant other than that specified on the Product's data label will void this limited warranty.
13. Any cost to replace, refill, or dispose of refrigerant, including the cost of refrigerant.
14. **ANY SPECIAL, INDIRECT, OR CONSEQUENTIAL PROPERTY OR COMMERCIAL DAMAGE OF ANY NATURE WHATSOEVER.** Some jurisdictions do not allow the exclusion of incidental or consequential damages, so this limitation may not apply to you.

This limited warranty gives you specific legal rights, and you may also have other rights that vary from jurisdiction to jurisdiction.

### LIMITATION OF WARRANTY

**THIS LIMITED WARRANTY IS EXCLUSIVE AND IS IN LIEU OF ALL OTHER WARRANTIES, CONDITIONS, AND/OR REMEDIES UNDER THE LAW, INCLUDING ANY IMPLIED WARRANTIES OR CONDITIONS OF MERCHANTABILITY OR FITNESS FOR A PARTICULAR PURPOSE. THE ORIGINAL OWNER'S SOLE REMEDY WITH RESPECT TO ANY PRODUCTS SHALL BE REPAIR OR REPLACEMENT OF DEFECTIVE COMPONENTS UNDER THE TERMS OF THIS LIMITED WARRANTY. ALL RIGHTS TO CONSEQUENTIAL OR INCIDENTAL DAMAGES (INCLUDING CLAIMS FOR LOST SALES, LOST PROFITS, PRODUCT LOSS, PROPERTY DAMAGES, OR SERVICE EXPENSES) ARE EXPRESSLY EXCLUDED. THE EXPRESS WARRANTIES MADE IN THIS LIMITED WARRANTY MAY NOT BE ALTERED, ENLARGED, OR CHANGED BY ANY DISTRIBUTOR, DEALER, OR OTHER PERSON, WHATSOEVER.**

### LEGAL REMEDIES

The owner **must** notify Taylor in writing by certified or registered letter to the following address of any defect or complaint with the Product, stating the defect or complaint and a specific request for repair, replacement, or other correction of the Product under warranty, mailed at least thirty (30) days before pursuing any legal rights or remedies.

Taylor Company  
750 N. Blackhawk Blvd.  
Rockton, IL 61072, U.S.A.

## TAYLOR COMPANY LIMITED WARRANTY ON TAYLOR GENUINE PARTS

Taylor Company is pleased to provide this limited warranty on new Taylor genuine replacement components and parts available from Taylor to the market generally (the "Parts") to the original purchaser only.

### LIMITED WARRANTY

Taylor warrants the Parts against failure due to defect in materials or workmanship under normal use and service as follows. All warranty periods begin on the date of original installation of the Part in the Taylor unit. If a Part fails due to defect during the applicable warranty period, Taylor, through an authorized Taylor distributor or service agency, will provide a new or re-manufactured Part, at Taylor's option, to replace the failed defective Part at no charge for the Part. Except as otherwise stated herein, these are Taylor's exclusive obligations under this limited warranty for a Part failure. This limited warranty is subject to all provisions, conditions, limitations and exclusions listed below and on the reverse (if any) of this document.

Table 11-1

Part's Warranty Class Code or Part	Limited Warranty Period
Class 103 Parts <sup>1</sup>	Three (3) Months
Class 212 Parts <sup>2</sup>	Twelve (12) Months
Class 512 Parts	Twelve (12) Months
Class 000 Parts	No Warranty

### LIMITED WARRANTY CONDITIONS

1. If the date of original installation of the Part cannot be otherwise verified, proof of purchase may be required at time of service.
2. This limited warranty is valid only if the Part is installed and all required service work in connection with the Part is performed by an authorized Taylor distributor or service agency.
3. The limited warranty applies only to Parts remaining in use by their original owner at their original installation location in the unit of original installation.
4. Installation, use, care, and maintenance must be normal and in accordance with all instructions contained in the Taylor Operator's Manual.
5. Defective Parts must be returned to the authorized Taylor distributor or service agency for credit.
6. This warranty is not intended to shorten the length of any warranty coverage provided pursuant to a separate Taylor limited warranty on freezer or grill equipment.
7. The use of any refrigerant other than that specified for the unit in which the Part is installed will void this limited warranty.

<sup>1, 2</sup> Except that Taylor Part #032129SER2 (Compressor-Air-230V SERV) and Taylor Part #075506SER1 (Compressor-Air-115V 60HZ) shall have a limited warranty period of twelve (12) months when used in Taylor freezer equipment and a limited warranty period of two (2) years when used in Taylor grill equipment.

## LIMITED WARRANTY ON PARTS

---

### LIMITED WARRANTY EXCEPTIONS

This limited warranty does **not** cover:

1. Labor or other costs incurred for diagnosing, repairing, removing, installing, shipping, servicing, or handling of defective Parts, replacement Parts, or new Parts.
2. Normal maintenance, cleaning, and lubrication as outlined in the Taylor Operator's Manual, including cleaning of condensers or carbon and grease buildup.
3. Required service, whether cleaning or general repairs, to return the cooking surface assemblies, including the upper platen and lower plate, to an operational condition to achieve proper cooking or allow proper assembly of release sheets and clips as a result of grease buildup on the cooking surfaces, including but not limited to the platen and plate, sides of the shroud, or top of the shroud.
4. Replacement of cooking surfaces, including the upper platen and lower plate, due to pitting or corrosion (or in the case of the upper platen, due to loss of plating) as a result of damage due to the impact of spatulas or other small wares used during the cooking process or as a result of the use of cleaners, cleaning materials, or cleaning processes not approved for use by Taylor.
5. Replacement of wear items designated as Class "000" Parts in the Taylor Operator's Manual, as well as any release sheets and clips for the Product's upper platen assembly.
6. External hoses, electrical power supplies, and machine grounding.
7. Parts not supplied or designated by Taylor, or damages resulting from their use.
8. Return trips or waiting time required because a service technician is prevented from beginning warranty service work promptly upon arrival.
9. Failure, damage, or repairs due to faulty installation, misapplication, abuse, no or improper servicing, unauthorized alteration or improper operation or use as indicated in the Taylor Operator's Manual, including but not limited to the failure to use proper assembly and cleaning techniques, tools, or approved cleaning supplies.
10. Failure, damage or repairs due to theft, vandalism, wind, rain, flood, high water, water, lightning, earthquake, or any other natural disaster, fire, corrosive environments, insect or rodent infestation, or other casualty, accident or condition beyond the reasonable control of Taylor; operation above or below the gas, electrical, or water supply specification of the unit in which a part is installed; Parts or the units in which they are installed repaired or altered in any way so as to, in the judgment of Taylor, adversely affect performance, or normal wear or deterioration.
11. Any Part purchased over the Internet.
12. Failure to start due to voltage conditions, blown fuses, open circuit breakers, or damages due to the inadequacy or interruption of electrical service.
13. Electricity, gas, or other fuel costs, or increases in electricity or fuel costs for any reason whatsoever.
14. Damages resulting from the use of any refrigerant other than that specified for the unit in which the Part is installed will void this limited warranty.
15. Any cost to replace, refill, or dispose of refrigerant, including the cost of refrigerant.
16. **ANY SPECIAL, INDIRECT, OR CONSEQUENTIAL PROPERTY OR COMMERCIAL DAMAGE OF ANY NATURE WHATSOEVER.** Some jurisdictions do not allow the exclusion of incidental or consequential damages, so this limitation may not apply to you.

This limited warranty gives you specific legal rights, and you may also have other rights which vary from jurisdiction to jurisdiction.

**LIMITATION OF WARRANTY**

**THIS LIMITED WARRANTY IS EXCLUSIVE AND IS IN LIEU OF ALL OTHER WARRANTIES, CONDITIONS, AND/OR REMEDIES UNDER THE LAW, INCLUDING ANY IMPLIED WARRANTIES OR CONDITIONS OF MERCHANTABILITY OR FITNESS FOR A PARTICULAR PURPOSE. THE ORIGINAL OWNER'S SOLE REMEDY WITH RESPECT TO ANY PRODUCTS SHALL BE REPAIR OR REPLACEMENT OF DEFECTIVE PARTS UNDER THE TERMS OF THIS LIMITED WARRANTY. ALL RIGHTS TO CONSEQUENTIAL OR INCIDENTAL DAMAGES, (INCLUDING CLAIMS FOR LOST SALES, LOST PROFITS, PRODUCT LOSS, PROPERTY DAMAGES OR SERVICE EXPENSES) ARE EXPRESSLY EXCLUDED. THE EXPRESS WARRANTIES MADE IN THIS LIMITED WARRANTY MAY NOT BE ALTERED, ENLARGED, OR CHANGED BY ANY DISTRIBUTOR, DEALER, OR OTHER PERSON, WHATSOEVER.**

**LEGAL REMEDIES**

The owner **must** notify Taylor in writing by certified or registered letter to the following address of any defect or complaint with the Part, stating the defect or complaint and a specific request for repair, replacement, or other correction of the Part under warranty, mailed at least thirty (30) days before pursuing any legal rights or remedies.

Taylor Company  
750 N. Blackhawk Blvd.  
Rockton, IL 61072, U.S.A.

