

# OPERATOR'S MANUAL



## Model 632 Combo Freezer

**Original Operating Instructions**

030049-M

03/2000 (Original Publication)  
(Updated 8/5/2020)



## Section 1: To the Installer

Installer Safety . . . . .	1-1
Site Preparation . . . . .	1-1
Air-Cooled Machines . . . . .	1-2
Water Connections . . . . .	1-2
Electrical Connections . . . . .	1-2
Beater Rotation . . . . .	1-3
Refrigerant . . . . .	1-4

## Section 2: To the Operator

## Section 3: Safety

## Section 4: Operator Parts Identification

Model 632 . . . . .	4-1
Soft Serve Door Assembly . . . . .	4-3
Shake Door Assembly . . . . .	4-5
Accessories . . . . .	4-6

## Section 5: User Interface

POWER SWITCH . . . . .	5-1
Indicator Light–MIX LOW . . . . .	5-1
MIX Key . . . . .	5-2
STANDBY Key . . . . .	5-2
WASH Key . . . . .	5-2
AUTO Key . . . . .	5-2
Thermistor Control . . . . .	5-2
RESET Button . . . . .	5-2
Air Tube (Soft Serve) . . . . .	5-3
Air Tube (Shake) . . . . .	5-3
Adjustable Draw Handle (Soft Serve Only) . . . . .	5-3

# Table of Contents

---

## Section 6: Operating Procedures

Set-Up for Machines with a Syrup Rail . . . . .	6-1
Soft Serve Side Freezing Cylinder Assembly . . . . .	6-1
Shake Side Freezing Cylinder Assembly . . . . .	6-5
Sanitizing . . . . .	6-7
Priming . . . . .	6-9
Closing Procedure . . . . .	6-10
Draining Product from the Freezing Cylinder . . . . .	6-10
Rinsing . . . . .	6-10
Cleaning . . . . .	6-10
Disassembly . . . . .	6-11
Brush Cleaning . . . . .	6-11

## Section 7: Important: Operator Checklist

During Cleaning and Sanitizing . . . . .	7-1
Troubleshooting Bacterial Count . . . . .	7-1
Regular Maintenance Checks. . . . .	7-2
Winter Storage . . . . .	7-2

## Section 8: Troubleshooting Guide

## Section 9: Parts Replacement Schedule

## Section 10: Limited Warranty on Equipment

## Section 11: Limited Warranty on Parts

The following information has been included in the manual as safety and regulatory guidelines. For complete installation instructions, please see the Installation Checklist.

## Installer Safety



**IMPORTANT!** In all areas of the world, machines should be installed in accordance with existing local codes. Please contact your local authorities if you have any questions.

Care should be taken to ensure that all basic safety practices are followed during the installation and servicing activities related to the installation and service of Taylor machines.

- Only authorized Taylor service personnel should perform installation and repairs on the machine.
- Authorized service personnel should consult OSHA Standard 29CFR1910.147 or the applicable code of the local area for the industry standards on lockout/tagout procedures before beginning any installation or repairs.
- Authorized service personnel must ensure that the proper personal protective equipment (PPE) is available and worn when required during installation and service.
- Authorized service personnel must remove all metal jewelry, rings, and watches before working on electrical equipment.



**DANGER!** The main power supply(s) to the machine must be disconnected prior to performing any repairs. Failure to follow this instruction may result in personal injury or death from electrical shock or hazardous moving parts, as well as poor performance or damage to the machine.

**Note:** All repairs must be performed by an authorized Taylor service technician.



**WARNING!** This machine has many sharp edges that can cause severe injuries.

## Site Preparation

Review the area where the machine will be installed before uncrating the machine. Make sure all possible hazards to the user or the equipment have been addressed.



**WARNING!** Only install this machine in a location where its use and maintenance is restricted to trained personnel. Failure to comply may result in personal injury.

**For Indoor Use Only:** This machine is designed to operate indoors, under normal ambient temperatures of 70°F to 75°F (21°C to 24°C). The freezer has successfully performed in high ambient temperatures of 104°F (40°C) at reduced capacities.



**WARNING!** This machine must **NOT** be installed in an area where a water jet or hose can be used. **NEVER** use a water jet or hose to rinse or clean the machine. Failure to follow this instruction may result in electrocution.



**CAUTION!** This machine must be installed on a level surface to avoid the hazard of tipping. Extreme care should be taken when moving this machine for any reason. Two or more persons are required to safely move this machine. Failure to comply may result in personal injury or machine damage.

Uncrate the machine and inspect it for damage. Report any damage to your Taylor distributor.

This machine is made in the USA and has USA sizes of hardware. All metric conversions are approximate and vary in size.

### 1 Air-Cooled Machines

**Do not** obstruct air intake and discharge openings:

Air-cooled machines require a minimum of 3 in. (76 mm) of clearance around **all** sides of the freezer to allow for adequate air flow across the condensers. A deflector is provided to prevent recirculation of warm air. Failure to allow adequate clearance can reduce the refrigeration capacity of the freezer and possibly cause permanent damage to the compressor.

### Water Connections

**Water-Cooled Machines Only:** An adequate cold water supply must be provided with a hand shut-off valve. On the underside rear of the base pan, two 1/2 in. Iron Pipe Size (IPS) water connections for inlet and outlet have been provided for easy hook-up. Permanently connect the machine using 1/2 in. (12.7 mm) inside diameter water lines. Flexible lines are recommended, if local codes permit. Depending on local water conditions, it may be advisable to install a water strainer to prevent foreign substances from clogging the automatic water valve. There will be only one water **in** and one water **out** connection for both single-head and double-head machines. **Do not** install a hand shut-off valve on the water **out** line. Water should always flow in this order: first, through the automatic water valve; second, through the condenser; and third, through the outlet fitting to an **open trap drain**.



**IMPORTANT!** A backflow prevention device is required on the incoming water connection side. Please see the applicable national, state, and local codes for determining the proper configuration. Water pressure to the unit must not exceed 150 psi (1034 kPa).

## Electrical Connections



**IMPORTANT!** In the United States, this machine is intended to be installed in accordance with the National Electrical Code (NEC), ANSI/NFPA 701987. The purpose of the NEC code is the practical safeguarding of persons and property from hazards arising from the use of electricity. This code contains provisions considered necessary for safety.

In all other areas of the world, machine should be installed in accordance with the existing local codes. Please contact your local authorities.

Each machine requires one power supply for each data label on the machine. Check the data label(s) on the machine for branch circuit overcurrent protection or fuse, circuit ampacity and other electrical specifications.

Refer to the wiring diagram provided inside the electrical box for proper power connections.



**FOLLOW YOUR LOCAL ELECTRICAL CODES.**

Each machine requires one power supply for each data label on the machine. Check the data label(s) on the freezer for branch circuit over current protection or fuse, circuit ampacity and other electrical specifications. Refer to the wiring diagram provided inside of the electrical box, for proper power connections.



**WARNING!** This machine must be properly grounded! Failure to do so can result in severe personal injury from electrical shock!



**IMPORTANT!** This machine is provided with an equipotential grounding lug that is to be properly attached to the rear of the frame by the authorized installer. The installation location is marked by the equipotential bonding symbol (5021 of IEC 60417-1) on the removable panel and the frame.

**NOTICE!**

- Stationary machines which are not equipped with a power cord and a plug or another device to disconnect the machine from the power source must have an all-pole disconnecting device with a contact gap of at least 0.125 in. (3 mm) installed in the external installation.
- Machines that are permanently connected to fixed wiring and for which leakage currents may exceed 10 mA, particularly when disconnected or not used for long periods, or during initial installation, shall have protective devices to protect against the leakage of current, such as a GFI, installed by the authorized personnel to the local codes.
- Supply cords used with this machine shall be oil-resistant, sheathed flexible cable not lighter than ordinary polychloroprene or other equivalent synthetic elastomer-sheathed cord (code designation 60245 IEC 57) installed with the proper cord anchorage to relieve conductors from strain, including twisting, at the terminals and protect the insulation of the conductors from abrasion.
- If the supply cord is damaged, it must be replaced by the manufacturer, service agent, or a similarly qualified person, in order to avoid a hazard.

**Beater Rotation**

**NOTICE!** Beater rotation must be clockwise as viewed looking into the freezing cylinder.

**Note:** *The following procedures must be performed by an authorized Taylor service technician.*

- To correct the rotation on a three-phase machine, interchange any two incoming power supply lines at freezer main terminal block.
- To correct rotation on a single-phase machine, change the leads inside the beater motor. Refer to the diagram printed on the motor.

Electrical connections are made directly to the terminal block provided in the main control box located behind the service panel.

**1**

### Refrigerant



**CAUTION!** This machine contains fluorinated greenhouse gases (F-Gas) to provide refrigeration using a hermetically sealed circuit or within foam insulation.

This machine's type of gas, quantity, Global Warming Potential (GWP), and CO2 tonnes equivalent information is recorded on the machine's data label. The refrigerant used is generally considered nontoxic and nonflammable. However any gas under pressure is potentially hazardous and must be handled with caution.

**NEVER** fill any refrigerant cylinder completely with liquid. Filling the cylinder approximately 80% will allow for normal expansion.



**CAUTION!** Use only approved refrigerant listed on the machine's data label or authorized through a manufacturer's technical bulletin. The use of any other refrigerant may expose users and operators to unexpected safety hazards.



**WARNING!** Refrigerant liquid sprayed onto the skin may cause serious damage to tissue. Keep eyes and skin protected. If refrigerant burns should occur, flush the area immediately with cold water. If burns are severe, apply ice packs and contact a physician immediately.



**NOTICE!** Taylor reminds technicians to be aware of government laws regarding refrigerant recovery, recycling, and reclaiming systems. If you have any questions regarding these laws, please contact the factory service department.



**IMPORTANT!** Refrigerants and their associated lubricants may be extremely moisture absorbent. When opening a refrigeration system, the maximum time the system is open must not exceed 15 minutes. Cap all open tubing to prevent humid air or water from being absorbed by the oil.

The freezer you have purchased has been carefully engineered and manufactured to give you dependable operation. The Taylor Model 632, when properly operated and cared for, produces a consistent quality product. Like all mechanical products, this machine requires cleaning and maintenance. A minimum amount of care and attention is necessary if the operating procedures outlined in this manual are followed.



**IMPORTANT!** This manual should be read before operating or performing any maintenance on your machine.

Your Taylor freezer will **NOT** eventually compensate for or correct any errors that occur during the set-up or filling operations. Thus, the initial assembly and priming procedures are of extreme importance. It is strongly recommended that personnel responsible for the machine's operation, assembly, and disassembly, go through these procedures together in order to be properly trained and to make sure that no confusion exists.

If you require technical assistance, please contact your local authorized Taylor distributor.

**Note:** Your Taylor warranty is valid only if the parts are authorized Taylor parts, purchased from the local authorized Taylor distributor, and only if all required service work is provided by an authorized Taylor service technician. Taylor reserves the right to deny warranty claims on machines or parts if parts not approved by Taylor or incorrect refrigerant were installed in the machine, system modifications were performed beyond factory recommendations, or it is determined that the failure was caused by abuse, misuse, neglect, or failure to follow all operating instructions. For full details of your Taylor Warranty, please see the Limited Warranty section in this manual.



**IMPORTANT!** If the crossed-out waste container symbol is affixed to this product, it signifies that this product is compliant with the EU Directive as well as other similar legislation in effect after August 13, 2005. Therefore, it must be collected separately after its use is completed, and cannot be disposed as unsorted municipal waste.

The user is responsible for delivering the product to the appropriate collection facility, as specified by your local code.

**Note:** Constant research results in steady improvements; therefore, information in this manual is subject to change without notice.

### Compressor Warranty Disclaimer

2 The refrigeration compressor(s) on this machine are warranted for the term stated in the Limited Warranty section in this manual. However, due to the Montreal Protocol and the U.S. Clean Air Act Amendments of 1990, many new refrigerants are being tested and developed, thus seeking their way into the service industry. Some of these new refrigerants are being advertised as drop-in replacements for numerous applications. It should be noted that in the event of ordinary service to this machine's refrigeration system, **only the refrigerant specified on the affixed data label should be used.** The unauthorized use of alternate refrigerants will void your Taylor compressor warranty. It is the machine owner's responsibility to make this fact known to any technician he employs.

It should also be noted that Taylor does not warrant the refrigerant used in its machines. For example, if the refrigerant is lost during the course of ordinary service to this machine, Taylor has no obligation to either supply or provide its replacement either at billable or unbillable terms. Taylor does have the obligation to recommend a suitable replacement if the original refrigerant is banned, obsoleted, or no longer available during the 5 year warranty of the compressor.

Taylor will continue to monitor the industry and test new alternates as they are being developed. Should a new alternate prove, through our testing, that it would be accepted as a drop-in replacement, then the above disclaimer would become null and void. To find out the current status of an alternate refrigerant as it relates to your compressor warranty, call the local Taylor distributor or the Taylor factory. Be prepared to provide the model/serial number of the machine in question.

We at Taylor Company are concerned about the safety of the operator when they come in contact with the freezer and its parts. Taylor has gone to extreme efforts to design and manufacture built-in safety features to protect both you and the service technician. For example, warning labels have been attached to the freezer to further point out safety precautions to the operator.



**DANGER!** Failure to adhere to the following safety precautions may result in severe personal injury or death. Failure to comply with these warnings may also damage the machine and/or its components. Such damage may require component replacement and service repair expenses.

### To Operate Safely



**NOTICE! DO NOT** operate the machine without reading the Operator Manual. Failure to follow this instruction may result in machine damage, poor machine performance, health hazards, or personal injury.



**IMPORTANT!** *This machine is to be used only by trained personnel. It is not intended for use, cleaning, or maintenance by children or people with reduced physical, sensory, or mental capabilities or lack of experience and knowledge, unless given supervision or instruction concerning the use of the machine by a person responsible for their safety. Children should be supervised to ensure that they do not play with the machine.*



**IMPORTANT!** *This machine is provided with an equipotential grounding lug that is to be properly attached to the rear of the frame by the authorized installer. The installation location is marked by the equipotential bonding symbol (5021 of IEC 60417-1) on the removable panel and the frame.*



**WARNING!** Avoid injury.

- **DO NOT** operate the machine unless it is properly grounded.
- **DO NOT** operate the machine with larger fuses than specified on the data label.
- All repairs must be performed by an authorized Taylor service technician.
- The main power supplies to machine must be disconnected prior to performing repairs.
- **For Cord-Connected Machines:** Only authorized Taylor service technicians or licensed electricians may install a plug or replacement cord on the machine.
- Stationary machines which are not equipped with a power cord and a plug or another device to disconnect the machine from the power source must have an all-pole disconnecting device with a contact gap of at least 0.125 in. (3 mm) installed in the external installation.
- Machines that are permanently connected to fixed wiring and for which leakage currents may exceed 10 mA, particularly when disconnected or not used for long periods, or during initial installation, shall have protective devices to protect against the leakage of current, such as a GFI, installed by the authorized personnel to the local codes.
- Supply cords used with this machine shall be oil-resistant, sheathed flexible cable not lighter than ordinary polychloroprene or other equivalent synthetic elastomer-sheathed cord (code designation 60245 IEC 57) installed with the proper cord anchorage to relieve conductors from strain, including twisting, at the terminals and protect the insulation of the conductors from abrasion.
- If the supply cord is damaged, it must be replaced by the manufacturer, service agent, or a similarly qualified person, in order to avoid a hazard.
- Secure the supply cord ground lead to the machine in a location where if the cord is pulled, the main power leads will become taut before the ground lead can break loose.



**WARNING!** This machine must **NOT** be installed in an area where a water jet or hose can be used. **NEVER** use a water jet or hose to rinse or clean the machine. Failure to follow this instruction may result in electrocution.

Failure to follow these instructions may result in electrocution. Contact your local authorized Taylor distributor for service.



**WARNING!** Avoid injury.

- 3**
- **DO NOT** allow untrained personnel to operate this machine.
  - **DO NOT** operate the machine unless all service panels and access doors are restrained with screws.
  - **DO NOT** remove any internal operating parts (examples: machine door, beater, scraper blades, etc.) unless all control switches are in the OFF position.

Failure to follow these instructions may result in severe personal injury to fingers or hands from hazardous moving parts.



**WARNING!** This machine has many sharp edges that can cause severe injuries.

- **DO NOT** put objects or fingers in the door spout. This may contaminate the product and cause severe personal injury from blade contact.
- **USE EXTREME CAUTION** when removing the beater assembly. The scraper blades are very sharp.
- **CAUTION-SHARP EDGES:** Two people are required to handle the cup/cone dispenser. Protective gloves must be worn and the mounting holes must **NOT** be used to lift or hold the dispenser. Failure to follow this instruction can result in personal injury to fingers or machine damage.



**CAUTION!** This machine must be placed on a level surface. Failure to comply may result in personal injury or machine damage.



**IMPORTANT!** Access to the service area of the machine is restricted to persons having knowledge and practical experience with the machine, in particular as far as safety and hygiene are concerned.



**NOTICE!** Cleaning and sanitizing schedules are governed by your federal, state, or local regulatory agencies and must be followed accordingly. Please see the cleaning section of this manual for the proper procedure to clean this machine.



**CAUTION!** This machine is designed to maintain product temperature under 41°F (5°C). Any product being added to this machine must be below 41°F (5°C). Failure to follow this instruction may result in health hazards and poor machine performance.

**DO NOT** obstruct air intake and discharge openings:

The minimum required air space on all sides is 3" (76 mm). A deflector is provided to prevent recirculation of warm air. Failure to follow this instruction may cause poor freezer performance and damage to the machine.

**For Indoor Use Only:** This machine is designed to operate indoors, under normal ambient temperatures of 70°F to 75°F (21°C to 24°C). The machine has successfully performed in high ambient temperatures of up to 104°F (40°C) at reduced capacities.

**DO NOT** run the machine without product. Failure to follow this instruction can result in damage to the machine.

**NOISE LEVEL:** Airborne noise emission does not exceed 78 dB(A) when measured at a distance of 39 inches (1.0 m) from the surface of the machine and at a height of 63 inches (1.6 m) from the floor.



Model 632

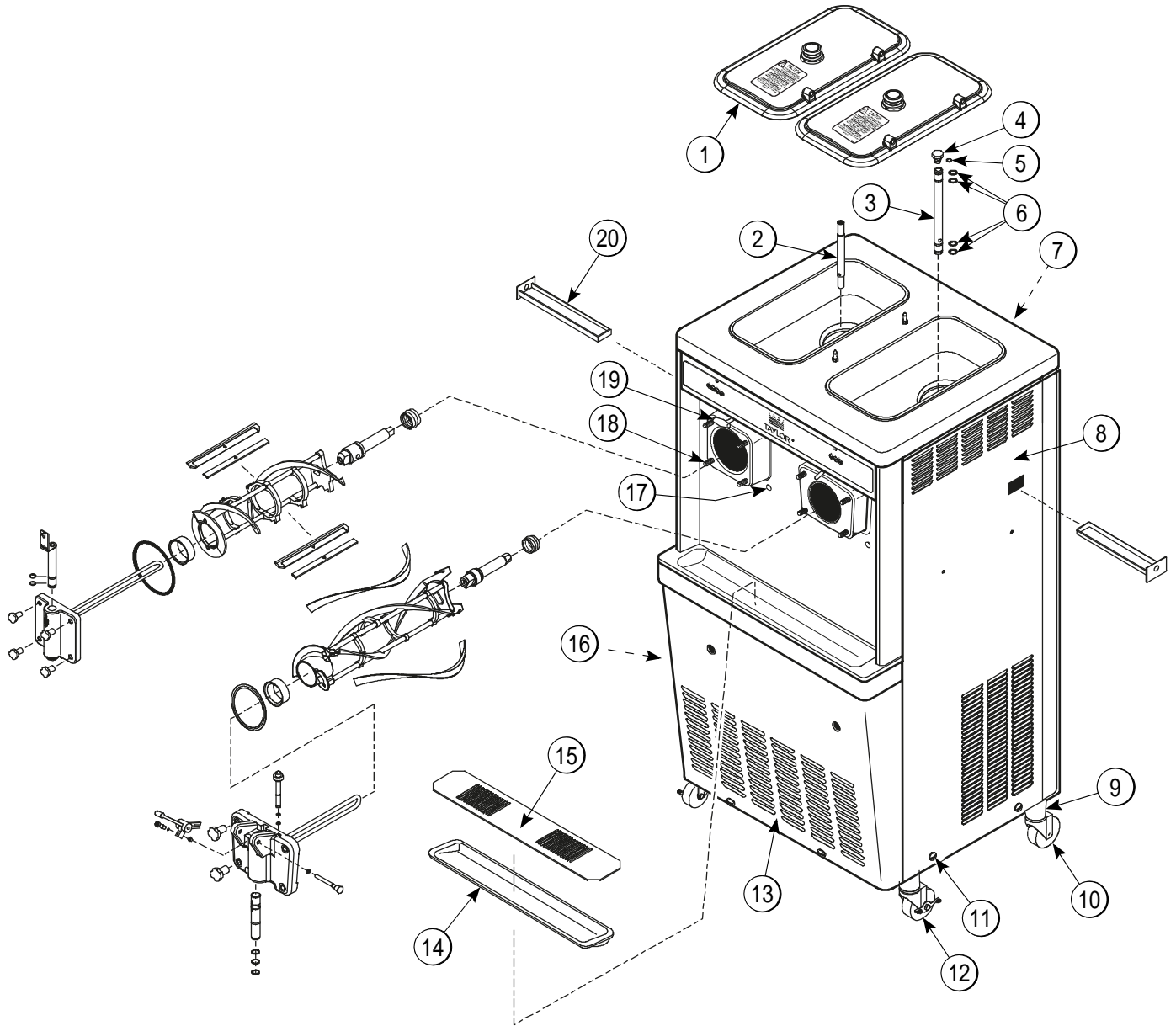

4

Figure 4-1

# OPERATOR PARTS IDENTIFICATION

## Model 632

Item	Description	Part No.
1	Kit A.-Cover-Hopper	X65369
2	Tube-Feed-Shake-5/16 Hole	<a href="#">028967-7</a>
3	Tube A.-Feed-SS-5/32 Hole	X29429-2
4	Orifice	<a href="#">022465-100</a>
5	O-ring-3/8 OD X .070 Wide (Bag of <a href="#">100</a> )	016137
6	O-ring-.643 OD X .077 Wide (Bag of 50)	018572
7	Panel-Rear	053782
8	Panel-Side-Right	067577
9	Adaptor A.-Caster	<a href="#">X18915</a>
10	Caster-SWV 5/8 Stem 4 in. Wheel	018794

Item	Description	Part No.
11	Screw-1/4-20X3/8 RHM-SS	011694
12	Caster-4" SWV 5/8 Stem w/Brake	034081
13	Panel-Service	024439
14	Tray-Drip 22-7/8 L X 5-1/5 W	014533
15	Shield-Splash	037041
16	Panel-Side-Left	067578
17	Bolt-Carriage 1/4-20 X 3/4 SS	012347
18	Stud-Nose Cone	022822
19	Knob-Draw Valve	013635
20	Pan-Drip 11-5/8 Long	027503

4

Soft Serve Door Assembly

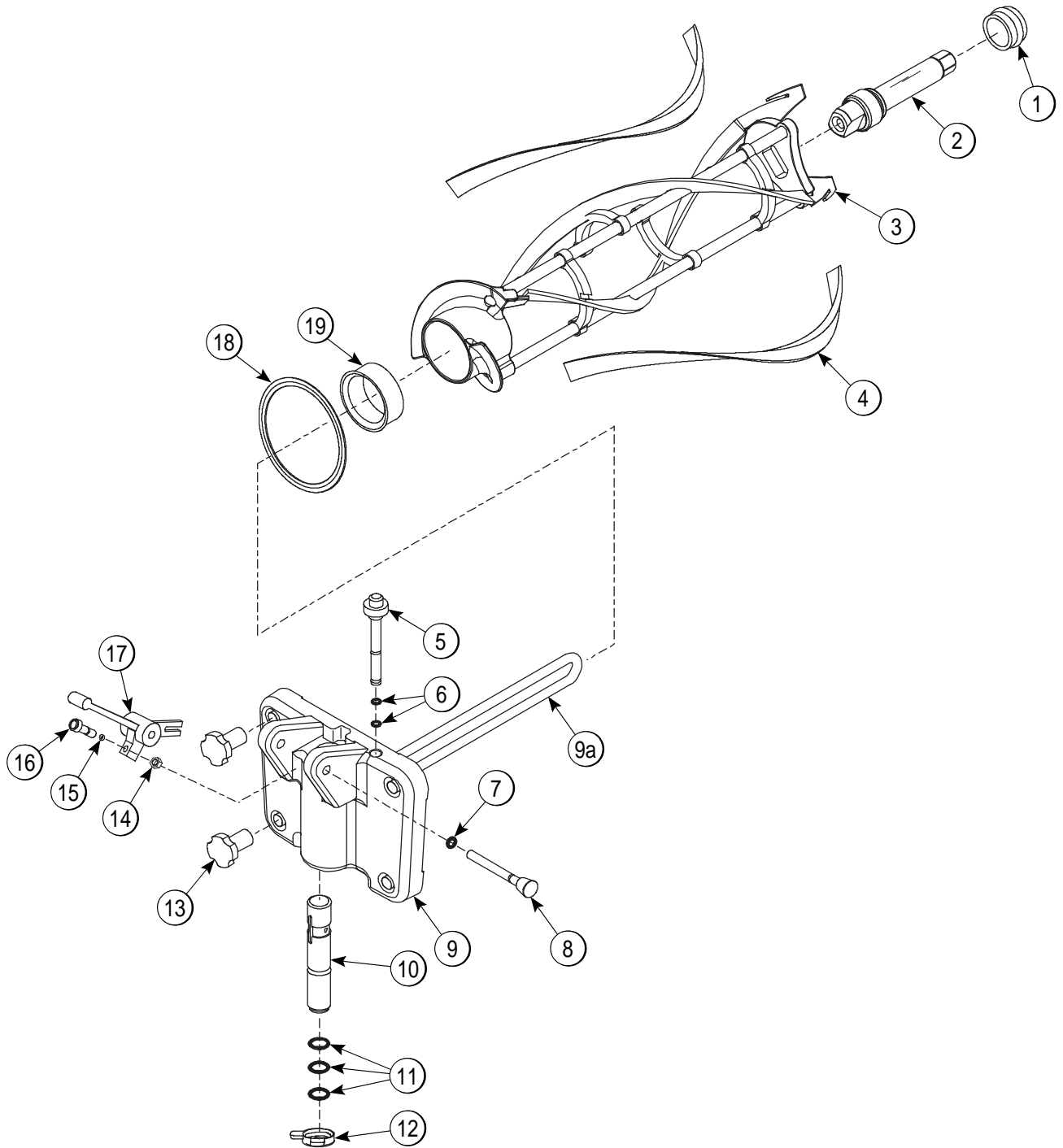

4

Figure 4-2

## OPERATOR PARTS IDENTIFICATION

### Soft Serve Door

Item	Description	Part No.
1	Seal-Drive Shaft	032560
2	Shaft-Beater	032564
3	Beater A. - 3.4QT-Helicore	X31761
4	Blade-Scraper- Plastic 17L	035174
5	Plug-Prime	028805
6	O-ring-3/8 OD X .070 W (Bag of 100)	016137
7	O-ring-5/16 OD X .070 W (Bag of 50)	016272
8	Pin A.-Pivot	X22820
9	Door A.-1 Spout	X51531-10
9a	Baffle A.-Long 4 in. w/RAD	X50882

Item	Description	Part No.
10	Valve A.-Draw	X18303
11	O-ring-7/8 OD X .103 W (Bag of 100)	014402
12	Cap-Design 1.010"ID-6 Point	014218
13	Nut-Stud	021508
14	Nut-Jam SS	029639
15	O-ring-1/4 OD X .070 W 50 Duro (Bag of 25)	015872
16	Screw-Adjustment-5/16-24	055092
17	Handle A.-Draw ADJ.	X55096
18	Gasket-Door HT 4"-Double	048926
19	Bearing-Front	050216

4

# Shake Door Assembly

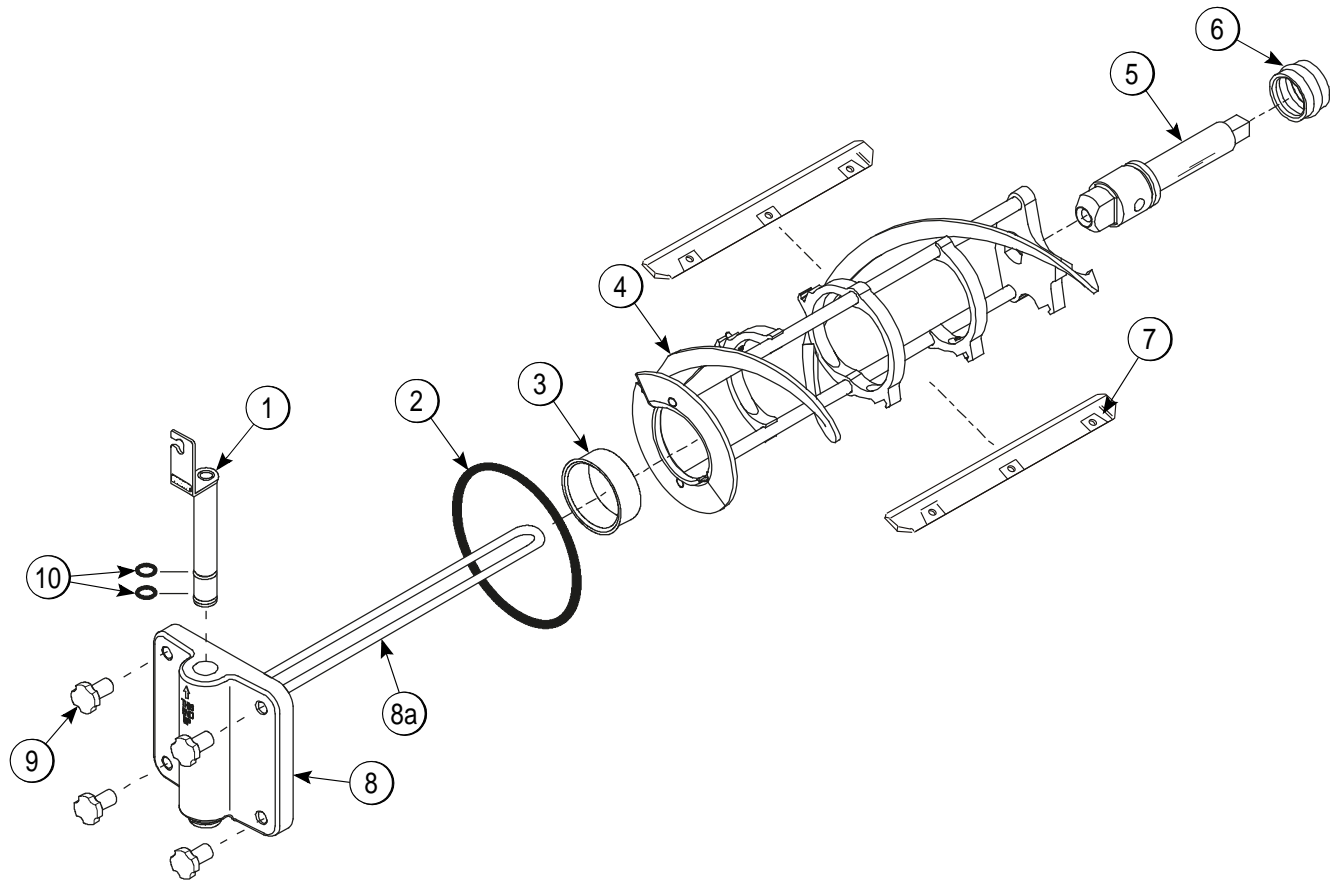

4

Figure 4-3

Item	Description	Part No.
1	Valve A.-Draw	<a href="#">X13624-SP</a>
2	Gasket-Door 5.177ID	016672
3	Bearing-Front	013116
4	Beater A.-7QT-1 Pin	<a href="#">X46233</a>
5	Shaft-Beater	032790
6	Seal-Drive Shaft	032560
7	Blade-Scraper-Plastic	084950

Item	Description	Part No.
8	Door A.-1 SPT-7QT-Partial	<a href="#">X30272-SER</a>
8a	Baffle A.-19 Inch	<a href="#">X30274</a>
9	Nut-Stud	021508
10	O-ring-1-1/16 OD X.139 W (100 to Bag)	020571
*	Decal-Lift Plate Front	015200

\*Not shown.

Accessories

4

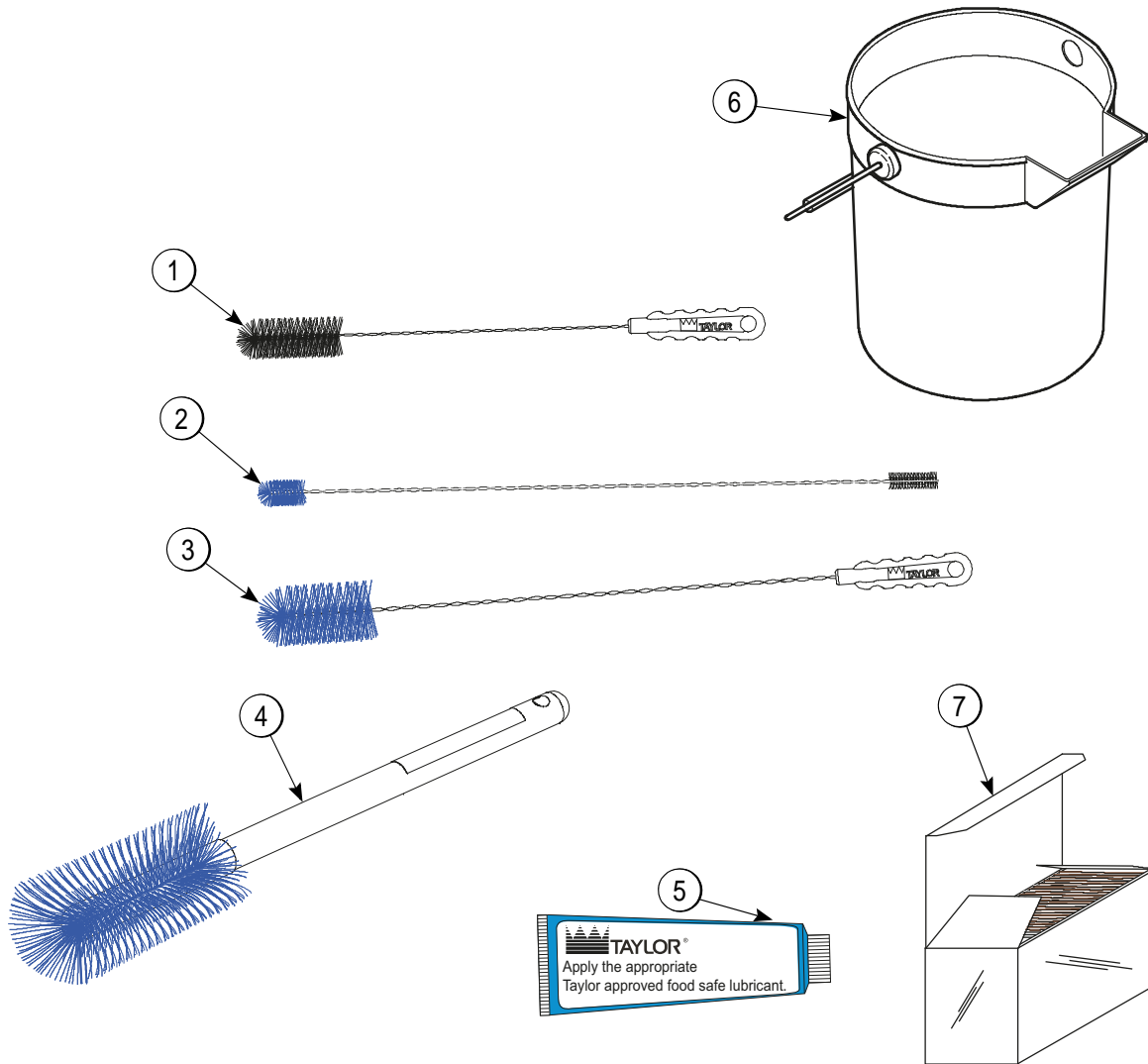

Figure 4-4

ITEM	DESCRIPTION	PART NO.
1	Brush-Rear BRG 1"D X 2" LG X 14	013071
2	Brush-DBL End-Pump and Feed Tube	013072
3	Brush-Draw Valve 1-1/2"OD X 3"	014753
4	Brush-Mix Pump Body- 3" X 7"	023316

ITEM	DESCRIPTION	PART NO.
5	Lubricant-Taylor 4 oz.	047518
6	Pail-Mix 10 qt.	013163
*7	Sanitizer-Stera Sheen®	See note.

**\*Note:** A sample container of sanitizer is sent with the machine. For reorders, order Stera Sheen® part no. 055492 (100 packs) or Kay-5® part no. 041082 (125 packs).

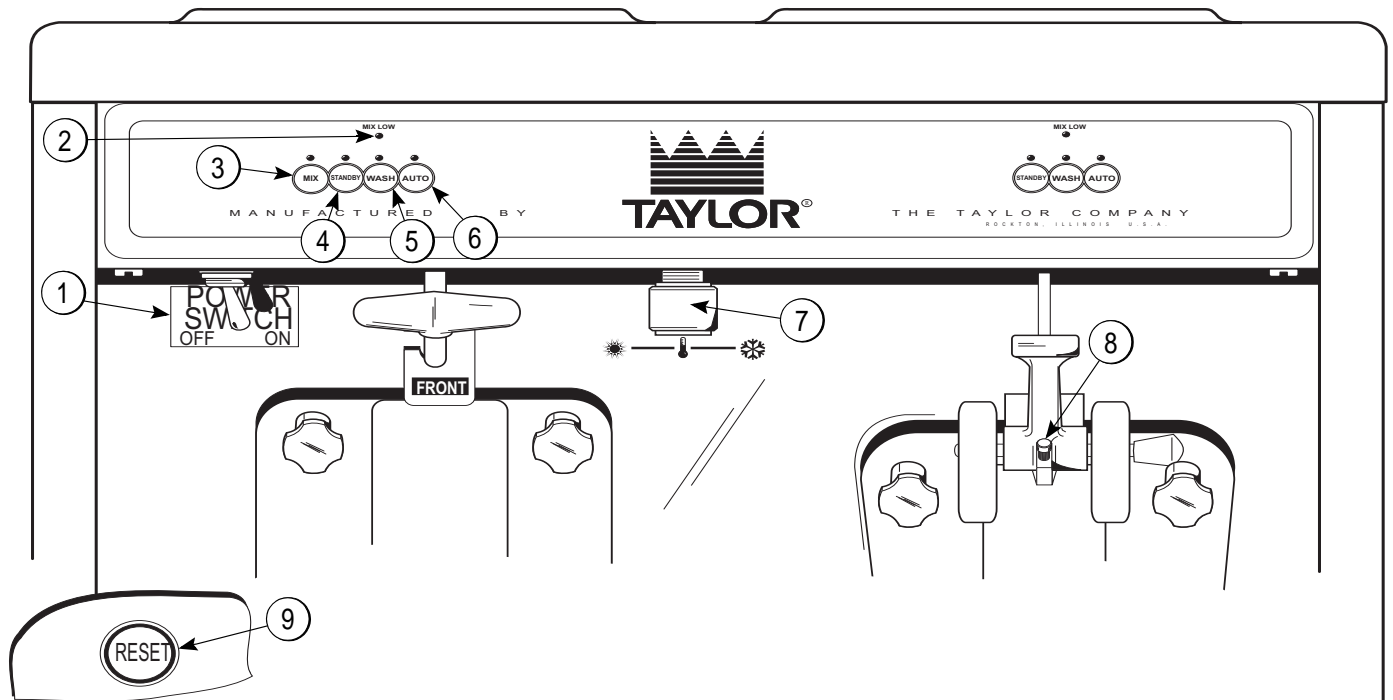

Figure 5-1

Item	Description
1	POWER SWITCH
2	MIX LOW Indicator Light
3	MIX Key (Hopper Refrigeration)
4	STANDBY Key
5	WASH Key
6	AUTO Key
7	Thermistor Control
8	Adjustable Draw Handle
9	RESET Button

**POWER SWITCH**

When placed in the ON position, the POWER SWITCH allows Softech™ control panel operation.

**Indicator Light–MIX LOW**

Located on the front of the machine is a mix level indicating light. When the MIX LOW light flashes, the mix hopper has a low supply of mix and should be refilled as soon as possible. Always maintain at least 3 in. (76 mm) of mix in the hopper. If you neglect to add mix, a freeze-up may occur. Insufficient mix will cause eventual damage to the beater, blades, drive shaft, and freezer door.

### MIX Key

When the MIX key is pressed, the light comes on indicating the mix hopper refrigeration system is operating. The Mix function is controlled by the left side of the freezer as viewed from the operator end. The Mix function cannot be cancelled unless the Auto or Standby modes are cancelled first.

### STANDBY Key

The Separate Hopper Refrigeration (SHR) system and the Cylinder Temperature Retention (CTR) system are standard features. The SHR system incorporates the use of a separate small refrigeration system to maintain the mix in the hopper below 40°F (4.4°C) to ensure bacteria control. The CTR system works with the SHR system to maintain a good quality product. If product is not dispensed for long periods of time, it is necessary to warm the product in the freezing cylinder to approximately 35°F to 40°F (1.7°C to 4.4°C) to prevent overbeating and product breakdown.

**5** To activate the SHR and CTR systems, press the STANDBY key. Remove the air orifice and place the air tube (**the end without the hole**) into the mix inlet hole.

When the STANDBY key is pressed, the light comes on, indicating the CTR system has been activated. In the Standby mode, the Wash and Auto functions are automatically cancelled. The Mix function is automatically locked in to maintain the mix in the hopper.

To resume normal operation, press the AUTO key. When the machine cycles off, the product in the freezing cylinder will be at serving viscosity. At this time, place the air tube (**the end with the hole**) into the mix inlet hole and install the air orifice.

### WASH Key

When the WASH key is pressed, the light comes on. This indicates beater motor operation. The Standby or Auto modes must be cancelled first to activate the Wash mode.

### AUTO Key

When the AUTO key is pressed, the light will come on indicating that the main refrigeration system has been activated. In the Auto mode, the Wash or Standby functions are automatically cancelled. The Mix function is automatically locked in to maintain the mix in the mix hopper.

**Note:** *An indicator light and an audible tone will sound whenever a mode of operation has been pressed. To cancel any function, press the key again. The light and mode of operation will shut off.*

### Thermistor Control

The thermistor control is used to vary the cycle off temperature for the shake side of the machine. The serving temperature of the shake can be made colder by turning the knob to the right. To achieve a warmer temperature, turn the knob to the left.

### RESET Button

The RESET button is located in the service panel. The reset protects the beater motor from an overload condition. If an overload occurs, the reset mechanism will trip. To properly reset the freezer, press the AUTO key to cancel the cycle. Turn the POWER SWITCH to the OFF position. Press the RESET button firmly.



**DANGER! DO NOT** use metal objects to press the RESET button. Failure to comply may result in severe personal injury or death.

Turn the POWER SWITCH to the ON position. Press the WASH key and observe the freezer's performance. Open the side access panel. Make sure the beater motor is turning the drive shaft in a clockwise direction (from the operator end) without binding.

If the beater motor is turning properly, press the WASH key to cancel the cycle. Press the AUTO key to resume normal operation.

## Air Tube (Soft Serve)

One end of the air tube has a hole in the side and the other end does not. An air orifice meters air into the freezing cylinder. The air orifice maintains overrun and allows enough mix to enter the freezing cylinder after a draw. The air tube serves two purposes.

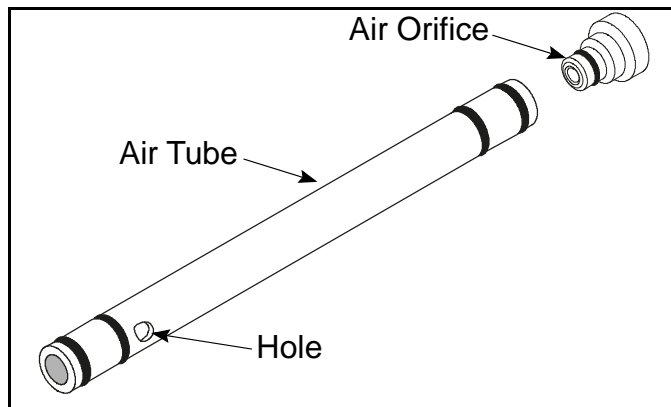

Figure 5-2

1. The air tube keeps the freezing cylinder properly loaded and maintains overrun. After priming the machine, lubricate the O-ring on the air tube (the end with the hole) and place it into the mix inlet hole. Every time the draw handle is raised, new mix and air from the hopper flows down into the freezing cylinder.
2. The air tube prevents any mix from entering the freezing cylinder during long periods of inactivity. Remove the air orifice. Lubricate the O-rings on the air tube (the end without the hole), and place it into the mix inlet hole.

## Air Tube (Shake)

After priming the machine, install the air tube with the hole (1) in the down position. This is the auto position, that allows mix and air to travel to the freezing cylinder while product is being dispensed.

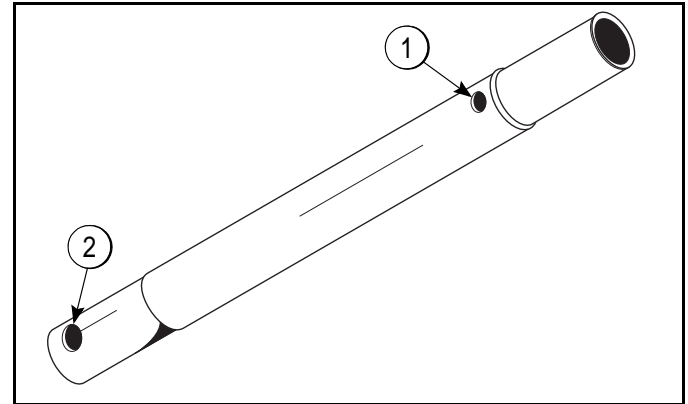

Figure 5-3

During long periods of inactivity, reverse the air tube. Install the air tube with the hole (2) in the down position. This is the standby position, which prevents any mix from entering the freezing cylinder.

**Note:** Make sure to place the air tubes in the correct position when returning the freezer to the Auto mode.

## Adjustable Draw Handle (Soft Serve Only)

These machines feature an adjustable draw handle to provide the best portion control. The draw handle should be adjusted to provide a flow rate of 5 to 7-1/2 oz. (142 to 212 g) of product per 10 seconds. To **increase** the flow rate, turn the screw **counterclockwise**. Turn the screw **clockwise** to **decrease** the flow rate. During sanitizing and rinsing, the flow rate can be increased by removing the pivot pin and placing the restrictive bar on the top. When drawing product, always place the restrictive bar on the bottom.



We begin our instructions at the point where we enter the store in the morning and find the parts disassembled and laid out to air dry from the previous night's cleaning.

These opening procedures show you how to assemble the parts into the freezer, sanitize them, and prime the freezer with fresh mix in preparation to serve your first portion.

If you are disassembling the machine for the first time or need information to get to this starting point in our instructions, refer to "Disassembly" page 6-11, and start there.

## Set-Up for Machines with a Syrup Rail

**Note:** This is an optional feature.

1. Remove the two stainless syrup jars with topping pumps from the syrup rail. Check the water level in the heated syrup topping well. Make sure the water is filled to the indicating mark on the bottom of the well.
2. Place the heater switch in the ON position.

**Note:** This heating process will take approximately 2-1/2 hours to reach temperature. The water level in the topping wells must be checked at least once daily.

3. Prepare a pail of approved 100 PPM sanitizing solution (examples: 2-1/2 gal. [9.5 L] of Kay-5® or 2 gal. [7.6 L] of Stera-Sheen®). **Use warm water and follow the manufacturer's specifications.** Sanitize the topping pumps by placing the entire pump assembly in the pail of sanitizing solution. Pump the solution through the assembly to thoroughly sanitize the pump.
4. Remove the two topping pumps. Fill each stainless syrup jar with topping. Place the topping pumps in the syrup jars.

## Soft Serve Side Freezing Cylinder Assembly

**Note:** When lubricating parts, use an approved food grade lubricant (example: Taylor Lube).



**WARNING!** Make sure the POWER SWITCH is in the OFF position. Failure to follow this instruction may result in severe personal injury from hazardous moving parts.

1. To install the drive shaft, lubricate the groove and shaft portion that comes in contact with the bearing on the beater drive shaft. Slide the seal over the shaft and groove until it snaps into place. **Do not** lubricate the hex end of the drive shaft. Fill the inside portion of the seal with 1/4 in. (6.3 mm) more lubricant and lubricate the flat side of the seal that fits onto the rear shell bearing.

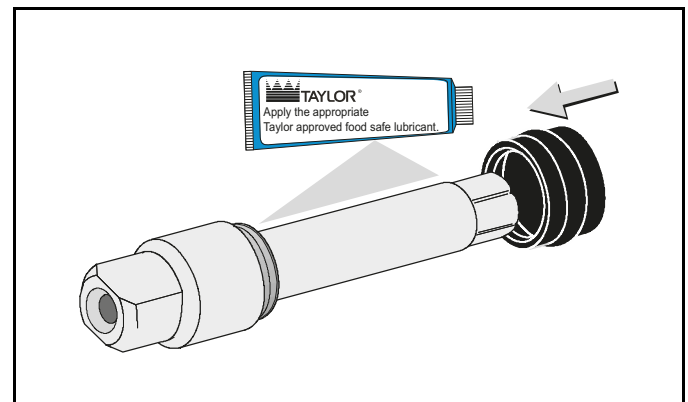

Figure 6-1

## OPERATING PROCEDURES

2. Insert the drive shaft into the freezing cylinder, hex end first, into the rear shell bearing, until the seal fits securely over the rear shell bearing. Engage the hex end firmly into the drive coupling. Make sure the drive shaft fits into the drive coupling without binding.

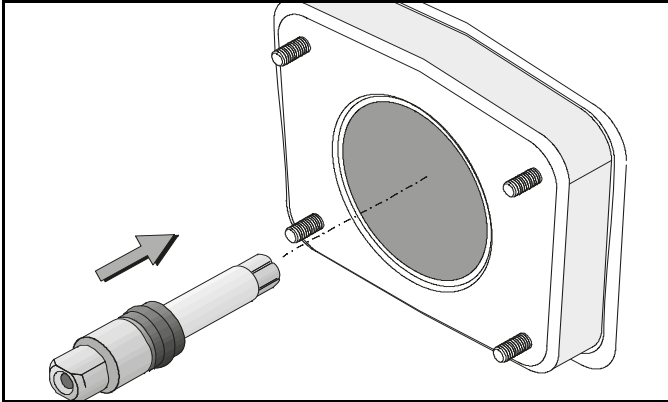

Figure 6-2

3. Take one of the scraper blades and slip it under the hook at the front of the beater. Wrap the blade around the beater following the helix. Push the blade down onto the helix as you wrap. At the back of the beater, slip the blade under the hook. **Repeat this step** for the second scraper blade.

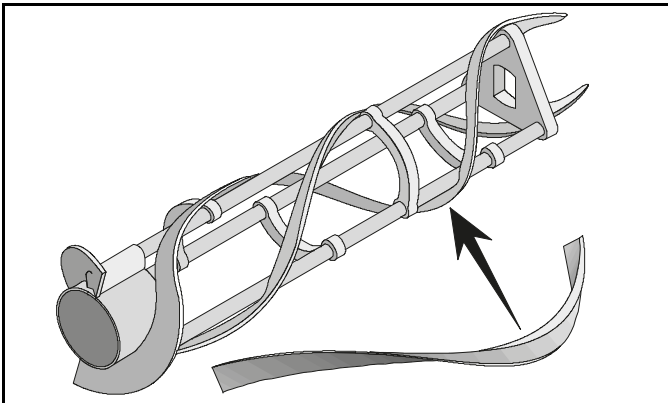

Figure 6-3

4. Holding the beater securely, slide the beater one third of the way into the freezing cylinder. Looking into the freezing cylinder, align the hole at the rear of the beater with the flats on the end of the drive shaft.

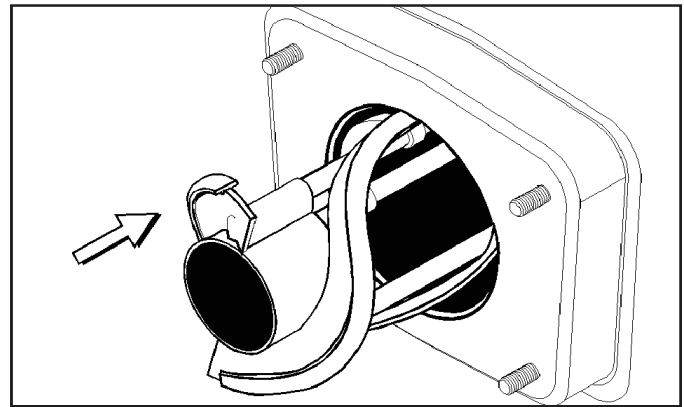

Figure 6-4

5. Slide the beater the remainder of the way into the freezing cylinder and over the end of the drive shaft. The beater should fit snugly, but not so tightly that the beater cannot be turned slightly to engage the drive shaft. If the beater slides in too easily with little or no resistance, there will not be enough force against the beater to hold the blades in place. If this is the case, contact your authorized Taylor service technician.
6. Before assembling the freezer door, check the following for any nicks, cracks, or signs of wear: the front bearing, door gasket, draw valve, O-rings, and all sides of the door assembly, including the inside of the draw valve bore. Replace any damaged parts.
7. Place the large rubber gasket in the groove on the back of the freezer door.
8. Slide the white plastic front bearing over the baffle rod onto the bearing hub, making certain the flanged end of the bearing is resting against the freezer door. **Do not** lubricate the gasket or the front bearing.

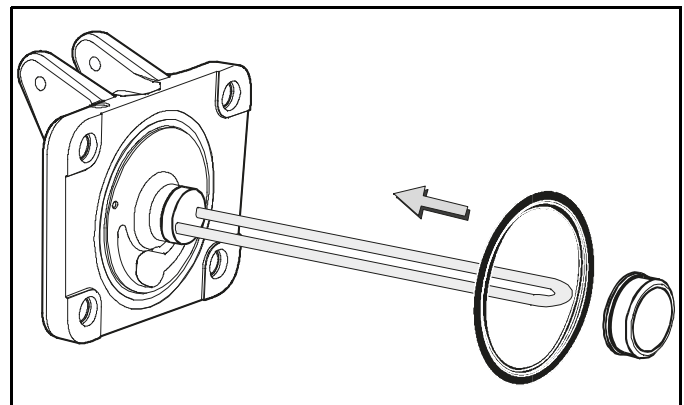

Figure 6-5

9. Slide the two O-rings into the grooves on the prime plug. Apply an even coat of Taylor Lube to the O-rings and shaft.

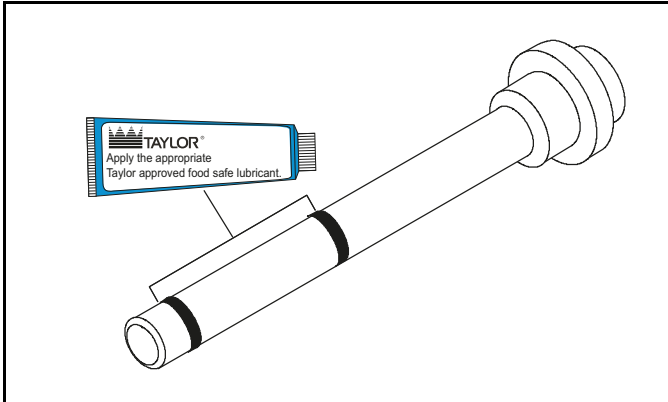

Figure 6-6

10. Insert the prime plug into the hole in the top of the freezer door, and push down.

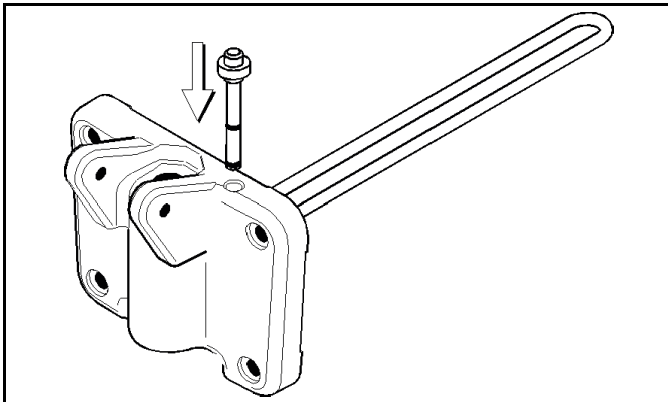

Figure 6-7

11. Install the freezer door. Insert the baffle rod through the opening in the beater and seat the door flush with the freezing cylinder. With the door seated on the freezer studs, install the handscrews. Tighten them equally in a crisscross pattern to insure the door is snug.

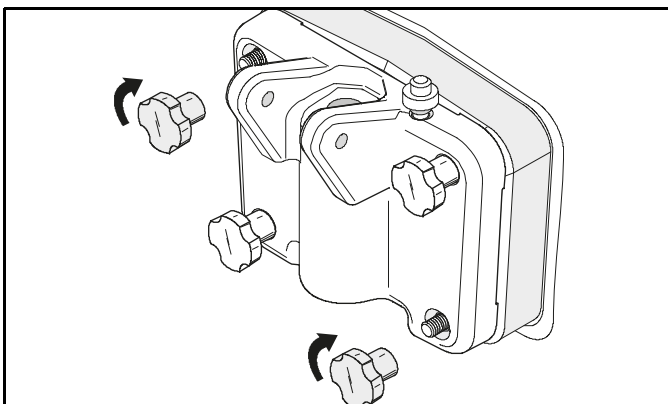

Figure 6-8

12. Install the draw valve. Slide the two O-rings into the grooves on the draw valve, and lubricate them.

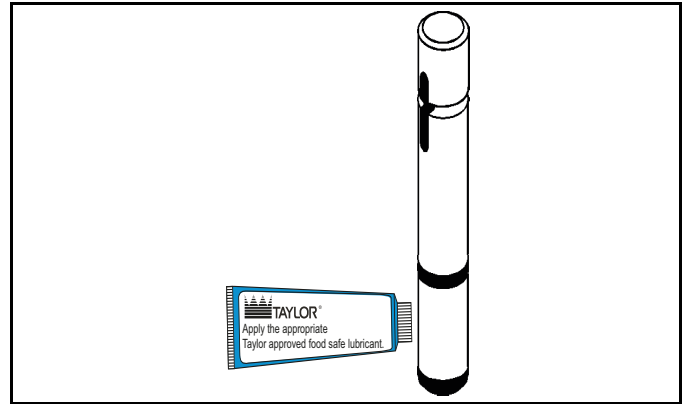

Figure 6-9

13. Lubricate the inside of the freezer door spout, top and bottom, and insert the draw valve from the **bottom** until the slot in the draw valve comes into view.

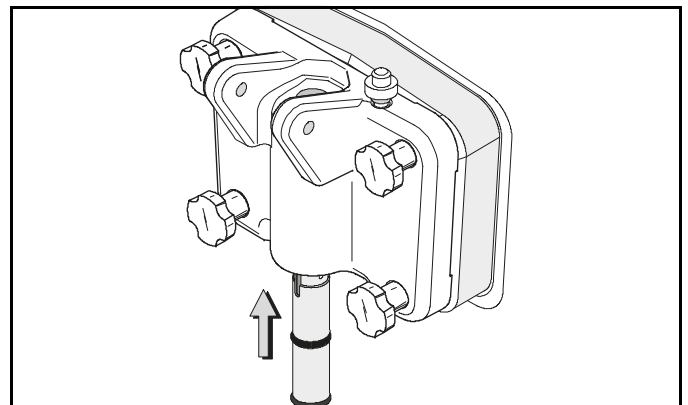

Figure 6-10

14. Install the adjustable draw handle. Slide the O-ring into the groove on the pivot pin, and lubricate it.

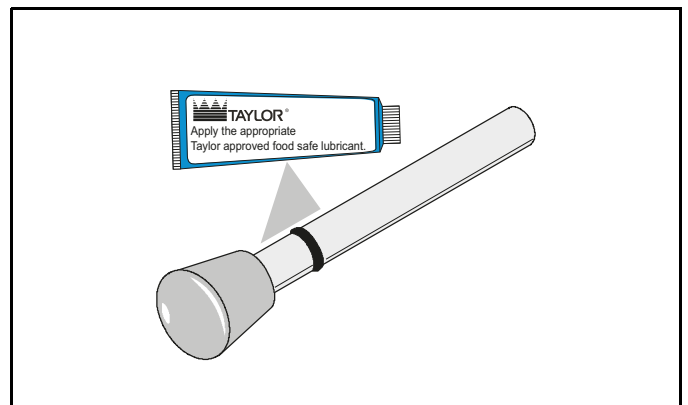

Figure 6-11

## OPERATING PROCEDURES

15. Slide the fork over the bar in the slot of the draw valve. Secure it with the pivot pin.

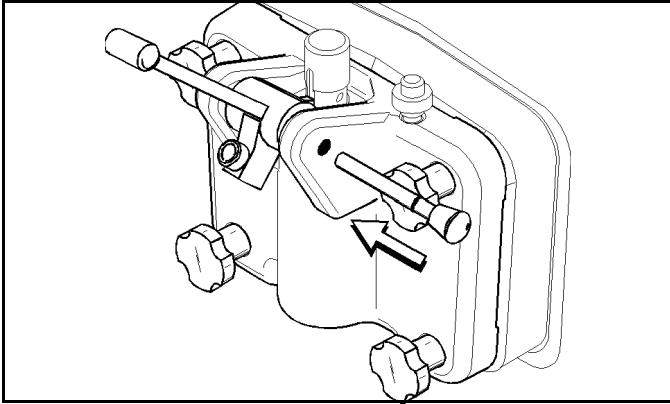

Figure 6-12

**Note:** These machines feature adjustable draw handles to provide the best portion control. The draw handles can be adjusted for different flow rates. See page 5-3 for more information on adjusting these handles.

16. Snap the design cap over the end of the door spout.

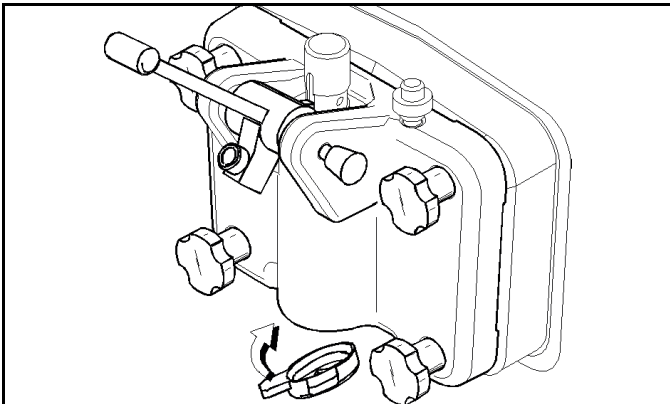

Figure 6-13

17. Slide two O-rings onto one end of the air tube. Slide two O-rings onto the other end of the air tube.

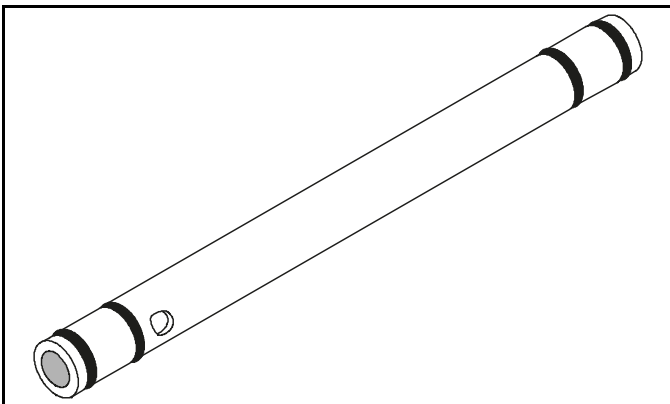

Figure 6-14

18. Slide the small O-ring into the groove of the air orifice. Do not lubricate the O-ring.

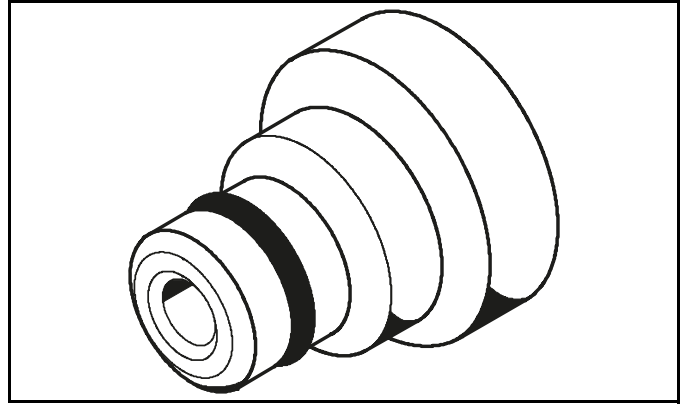

Figure 6-15

**Note:** Make the air orifice is clean and not clogged. If the air orifice should become clogged, use soap and hot water to clear it. **Do not** enlarge the hole in the air orifice.

19. Install the air orifice into the hole in the top of the air tube (in the end without the hole on the side).

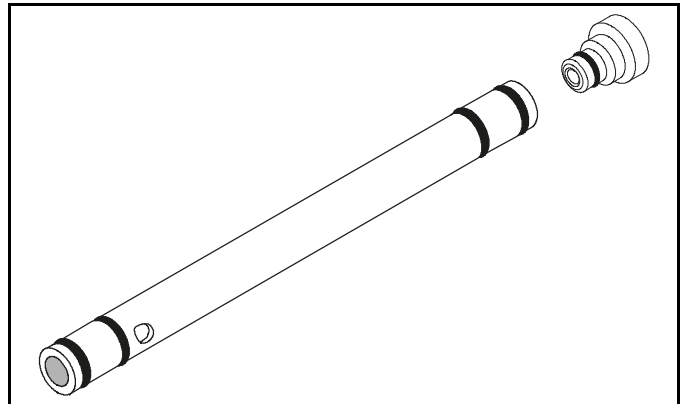

Figure 6-16

20. Lay the air tube (with the air orifice installed) in the bottom of the mix hopper for sanitizing.

**Note:** The air tube for the shake side does not require O-rings or an air orifice.

## Shake Side Freezing Cylinder Assembly

**Note:** When lubricating parts, use an approved food grade lubricant (example: Taylor Lube).



**WARNING!** Make sure the POWER SWITCH is in the OFF position. Failure to follow this instruction may result in severe personal injury from hazardous moving parts.

1. To install the drive shaft, lubricate the groove and shaft portion that comes in contact with the bearing on the beater drive shaft. Slide the seal over the shaft and groove until it snaps into place. **Do not** lubricate the hex end of the drive shaft. Fill the inside portion of the seal with 1/4 in. (6.3 mm) more lubricant and lubricate the flat side of the seal that fits onto the rear shell bearing.

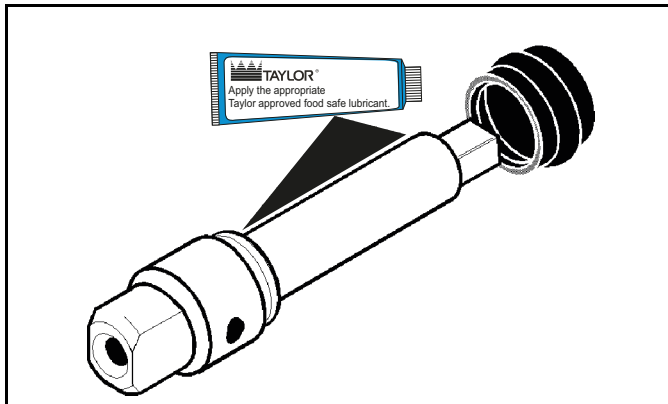

Figure 6-17

2. Insert the drive shaft into the freezing cylinder, hex end first, and into the rear shell bearing, until the seal fits securely over the rear shell bearing. Engage the hex end firmly into the drive coupling. Make sure the drive shaft fits into the drive coupling without binding.

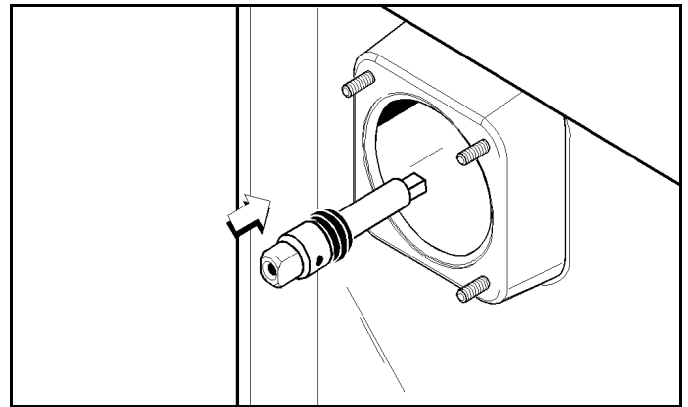

Figure 6-18

3. Before installing the beater assembly, inspect the scraper blades for any signs of wear or damage. If a scraper blade is nicked or worn, replace both blades.

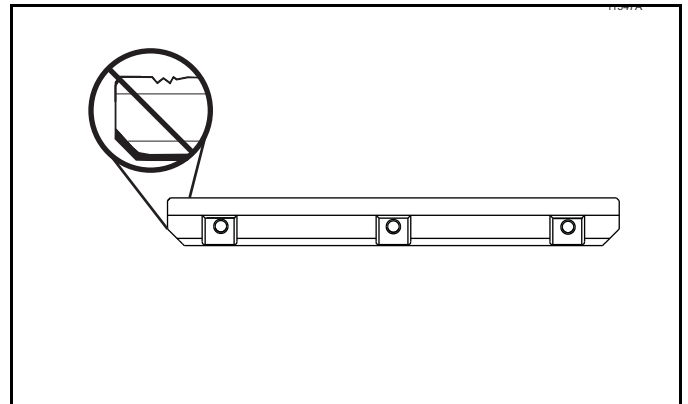

Figure 6-19

## OPERATING PROCEDURES

- If the blades are in good condition, place the rear scraper blade over the rear holding pin on the beater (knife edge to the outside). Holding the rear blade on the beater, slide the assembly halfway into the freezing cylinder, tail end first. Install the front scraper blade over the front holding pin. Slide the beater assembly completely into the freezing cylinder.

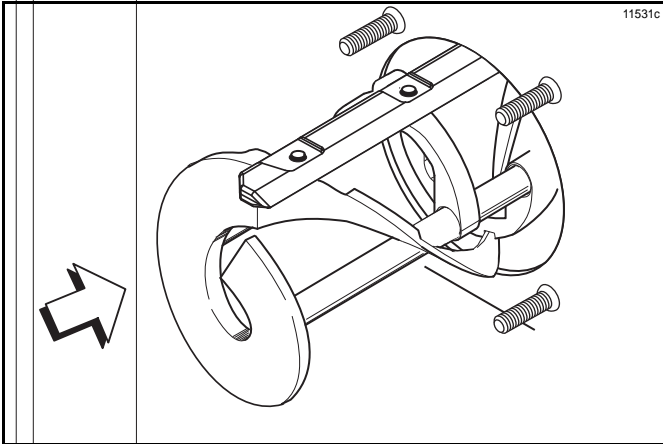

Figure 6-20

**Note:** To prevent costly damage, the hole on the scraper blade must fit securely over the pin.

- Before assembling the freezer door, check the following for any nicks, cracks, or signs of wear: the front bearing, door gasket, draw valve, O-rings, and all sides of the door assembly, including the inside of the draw valve bore. Replace any damaged parts.
- Slide the two O-rings into the grooves on the draw valve and lubricate the bottom 1/2 of the valve.

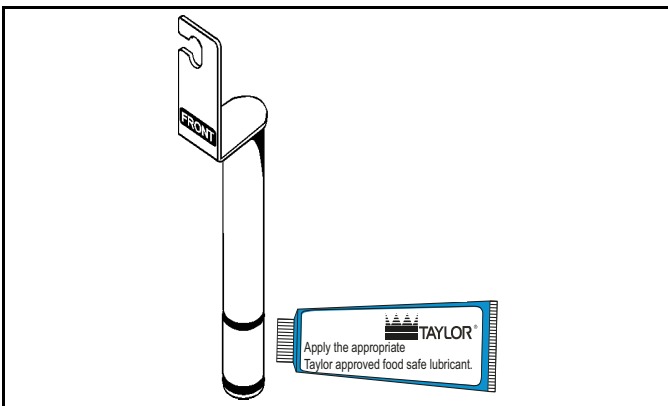

Figure 6-21

- Lubricate the inside of the freezer door spout, top and bottom, and insert the draw valve into the freezer door from the top. It will be necessary to rotate the draw valve to the right when assembling the door to the freezer.

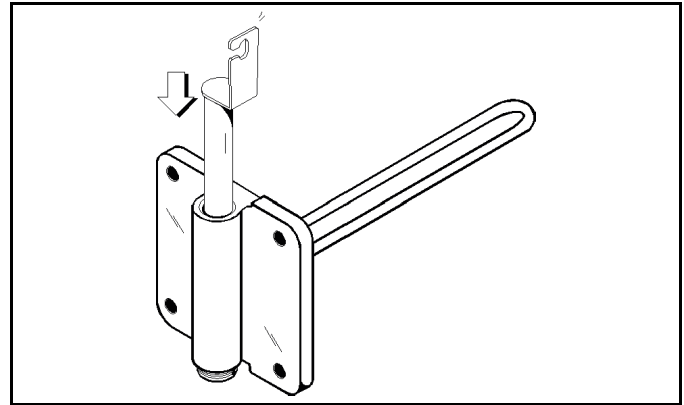

Figure 6-22

- Place the freezer door gasket into the groove on the back of the freezer door. Slide the front bearing over the baffle rod so the flanged edge is against the door. **Do not** lubricate the gasket or bearing.

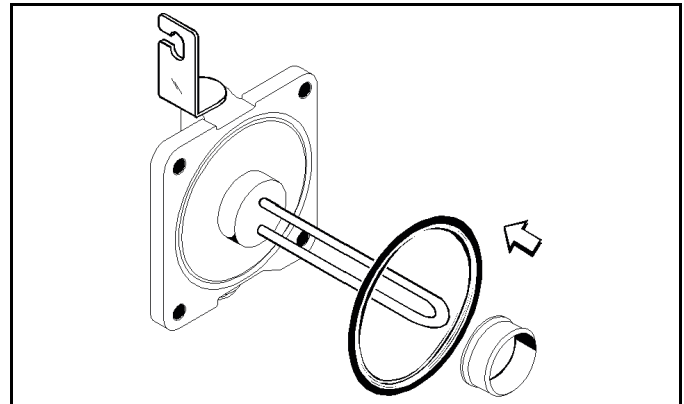

Figure 6-23

- Insert the baffle rod through the beater in the freezing cylinder. With the door seated on the freezer studs, install the handscrews. Tighten them equally in a criss-cross pattern to insure the door is snug.

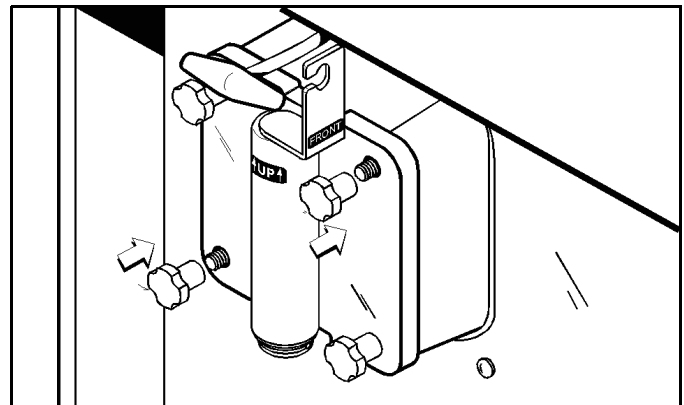

Figure 6-24

10. Rotate the draw valve bracket to the left and center it by raising the draw arm and placing it into the slotted groove of the draw valve bracket.

**Note:** The draw valve bracket must be positioned with the notch to the left.

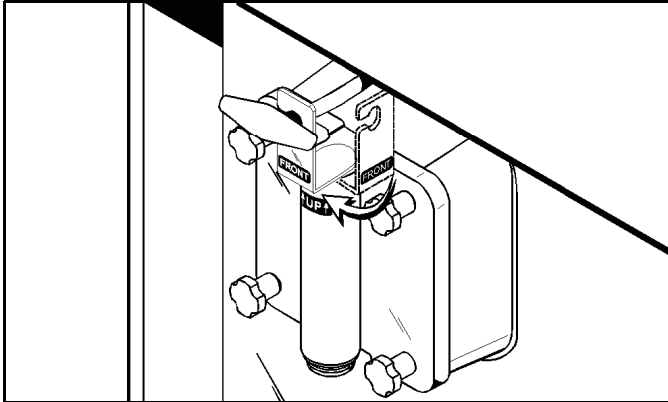

Figure 6-25

11. Lay the air tube in the bottom of the mix hopper.
12. Slide the rear drip pan(s) into the hole in the side panel.

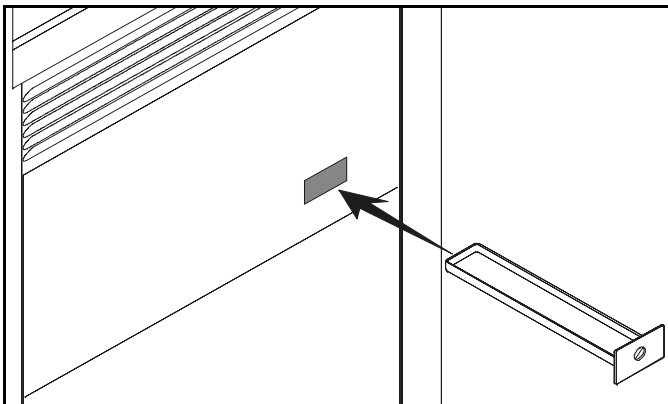

Figure 6-26

13. Install the drip tray and splash shield.

## Sanitizing

1. Prepare a pail of approved 100PPM sanitizing solution (examples: 2-1/2 gal. [9.5 liters] of Kay-5® or 2 gal. [7.6 liters] of Stera-Sheen®). **Use warm water and follow the manufacturer's specifications.**
2. Pour the sanitizing solution into the hopper and allow it to flow into the freezing cylinder.

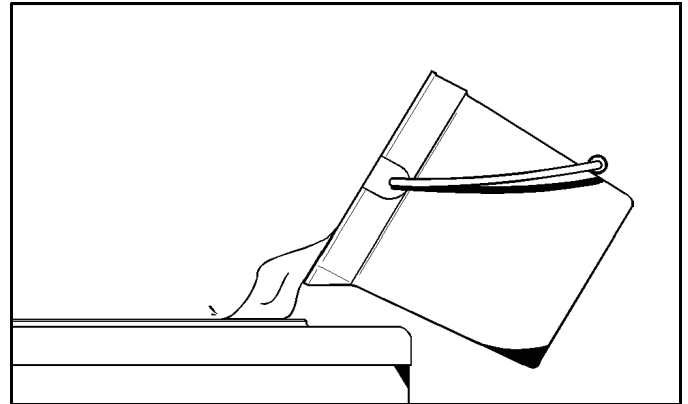

Figure 6-27

3. While the solution is flowing into the freezing cylinder, brush clean the mix hopper. While cleaning the mix hopper, take particular care when brushing the mix level sensing probe on the rear wall of the hopper, the mix inlet hole, and the air tubes.

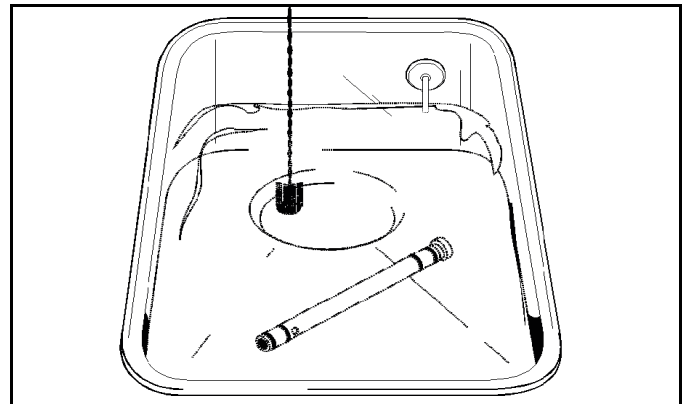

Figure 6-28

4. Place the POWER SWITCH in the ON position.

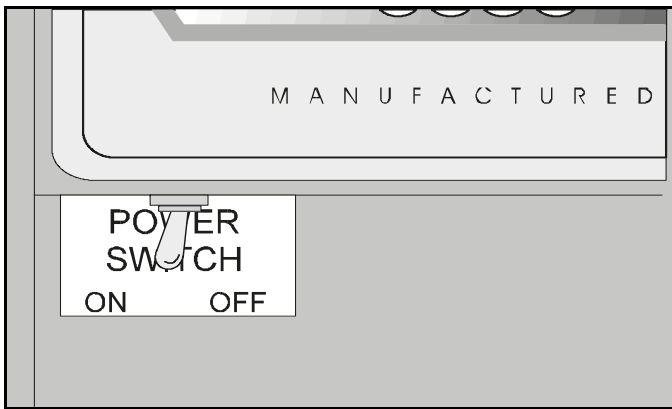

Figure 6-29

5. Press the WASH key. This causes the sanitizing solution in the freezing cylinder to agitate. Allow the solution to agitate for 5 minutes.

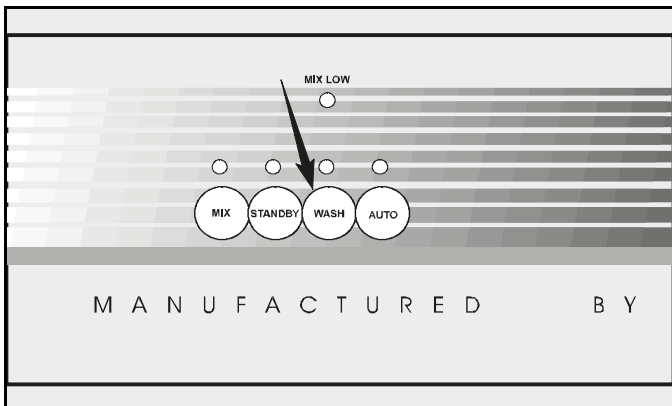

Figure 6-30

6. Place an empty pail beneath the door spout. Raise the prime plug (soft serve side only).

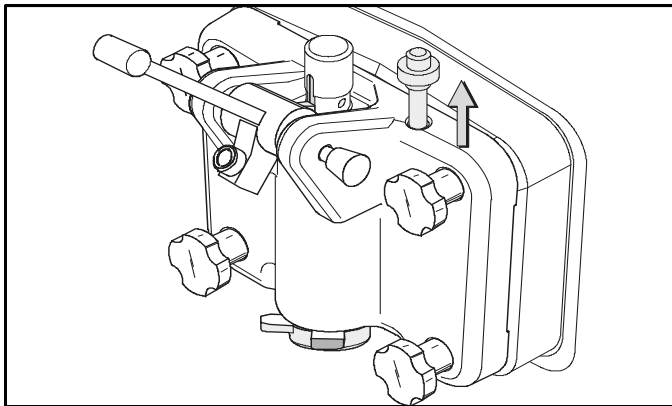

Figure 6-31

7. When a **steady** stream of sanitizing solution flows from the prime plug opening in the bottom of the freezer door, open the draw handle. Draw off all the sanitizing solution.

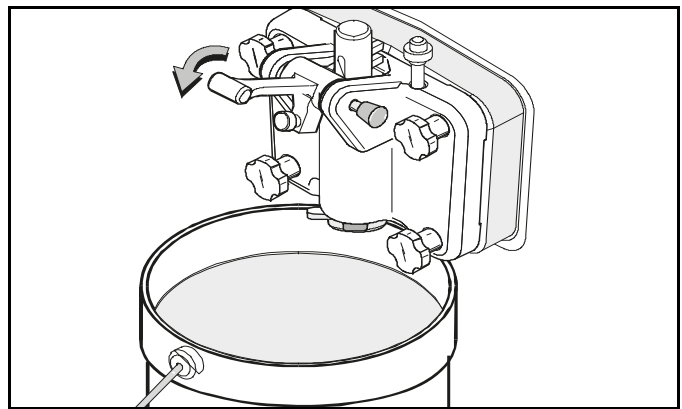

Figure 6-32

8. Once the sanitizer stops flowing from the door spout, close the draw handle and press the WASH key, cancelling the beater motor operation.

**Important!** The machine must **not** be placed in Auto mode until all sanitizing solution has been removed from the freezing cylinder and proper priming procedures have been completed. Failure to follow this instruction may result in damage to the freezing cylinder.

**Note:** You have just sanitized the freezer. Make sure your hands are sanitized before continuing these instructions.

9. Stand the air tube in the corner of the hopper.

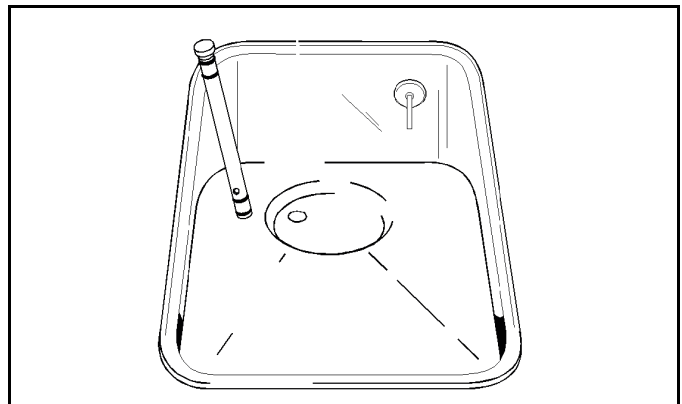

Figure 6-33

10. Repeat steps 1 through 9 for the shake side of the freezer.

## Priming

1. With a pail beneath the door spout, open the draw handle. Make sure the prime plug is still in the **up** position (soft serve side only). Pour two gal. (7.6 L) of fresh mix into the mix hopper and allow it to flow into the freezing cylinder. This forces out any remaining sanitizing solution. When full strength mix is flowing from the door spout, close the draw handle.

**Note:** Use only **fresh** mix when priming the freezing cylinder.

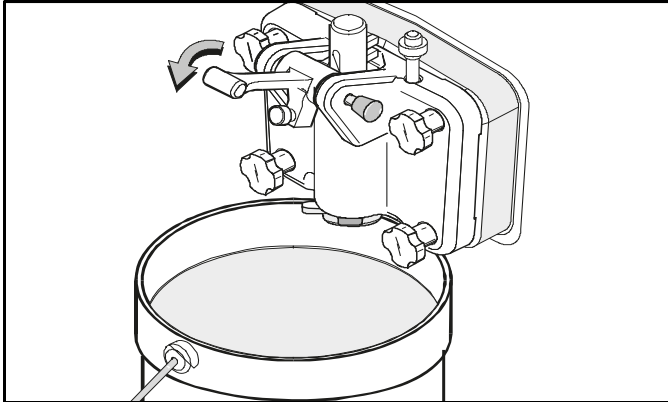

Figure 6-34

2. Once a **steady** stream of mix starts to flow from the prime plug opening in the bottom of the freezer door, push down the prime plug (soft serve only).

**Important!** Failure to remove all sanitizing solution may result in damage to the freezing cylinder.

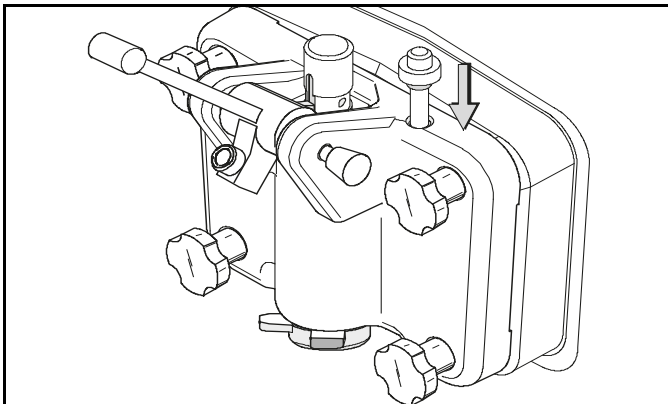

Figure 6-35

3. Lubricate the O-rings on the air tube on the end with the small hole on the side (soft serve only).

4. Install the air tube (the end with the hole) with the air orifice installed into the mix inlet hole in the mix hopper (soft serve only).

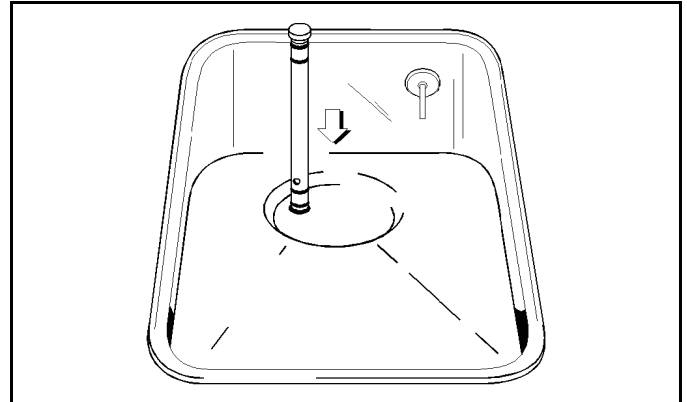

Figure 6-36

5. Press the AUTO key. The AUTO light will come on indicating the main refrigeration system is operating. When the machine cycles off, the product is at serving viscosity.

**Note:** The MIX light will also come on, indicating the mix refrigeration system is operating to maintain the mix in the mix hopper.

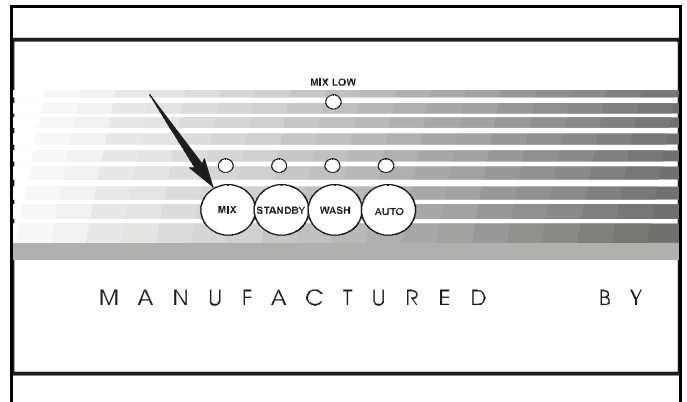

Figure 6-37

6. Fill the hopper with mix. As the mix level comes in contact with the mix level sensing probe on the rear wall of the hopper, the MIX LOW light will shut off.
7. Place the mix hopper cover in position over the mix hopper.
8. Repeat step 1 through step 7 for the other side of the freezer.

### Closing Procedure

To disassemble your machine, the following items are needed:

- Two cleaning pails
- Sanitized stainless steel rerun container with lid
- Necessary brushes (provided with freezer)
- Cleaner
- Single-service towels

### Draining Product from the Freezing Cylinder

1. Press the AUTO key, cancelling compressor and beater motor operation.

Press the MIX key, cancelling the mix hopper refrigeration system.

2. Remove the hopper cover, hopper gasket and air tube. Take these parts to the sink for cleaning.
3. If local health codes permit the use of rerun, place a sanitized, National Sanitation Foundation (NSF) approved stainless steel rerun container beneath the door spout. Press the WASH key and open the draw handle. Drain the remaining product from the freezing cylinder and mix hopper. When the flow of product stops, press the WASH key and close the draw handle. Place the sanitized lid on the rerun container and place it in the walk-in cooler.

**Note:** If local health codes **do not** permit the use of rerun, the product must be discarded. Follow the instructions in the previous step, except drain the product into a pail and properly discard the mix.



4. Repeat steps 1 through 3 for the other side of the freezer.

### Rinsing

1. Pour 2 gal. (7.6 L) of **cool** clean water into the mix hopper. With the brushes provided, scrub the mix hopper, mix inlet hole and mix level sensing probe.
2. With a pail beneath the door spout, (raise the prime plug - soft serve only) and press the WASH key.
3. When a steady stream of rinse water is flowing from the prime plug opening in the bottom of the freezer door (soft serve only), open the draw handle. Drain all the rinse water from the freezing cylinder, close the draw handle and press the WASH key cancelling the Wash mode.
4. Repeat steps 1 through 3 for the shake side of the freezer.

### Cleaning

1. Prepare a pail of approved **100 PPM** cleaning solution (examples: 2-1/2 gal. [9.5 L] of Kay-5® or 2 gal. [7.6 L] of Stera-Sheen®). **Use warm water and follow the manufacturer's specifications.**
2. Push down the prime plug (soft serve only). Pour the cleaning solution into the mix hopper.
3. While the solution is flowing into the freezing cylinder, brush clean the mix hopper, mix level sensing probe, and the mix inlet hole.
4. Press the WASH key. This causes the cleaning solution in the freezing cylinder to agitate.
5. Place an empty pail beneath the door spout and raise the prime plug (soft serve only).
6. When a steady stream of cleaning solution is flowing from the prime plug opening in the bottom of the freezer door (soft serve only), open the draw handle. Draw off all of the solution.
7. Once the cleaner stops flowing from the door spout, close the draw handle and press the WASH key cancelling the Wash mode.
8. Repeat steps 1 through 7 for the other side of the freezer.

## Disassembly



**WARNING!** Make sure the POWER SWITCH is in the OFF position! Failure to follow this instruction may result in severe personal injury to fingers or hands from hazardous moving parts.

1. Remove the handscrews, freezer door(s), beater(s), scraper blades, and drive shaft(s) from the freezing cylinder(s). Take these parts to the sink for cleaning.
2. Remove the front drip tray and the splash shield.

## Brush Cleaning

1. Prepare a sink with an approved cleaning solution (examples: Kay-5<sup>®</sup> or Stera-Sheen<sup>®</sup>). **Use warm water and follow the manufacturer's specifications.** If another approved cleaner is used, dilute it according to the label instructions.

**Important!** Follow the manufacturer's label directions. Too **strong** of a solution can cause parts damage, while too **mild** of a solution will not provide adequate cleaning.) Make sure all brushes provided with the freezer are available for brush cleaning.

2. Remove the seal(s) from the drive shaft(s).
3. From the freezer door(s) remove:
  - gasket(s)
  - front bearing(s)
  - pivot pin(s)
  - adjustable draw handle(s)
  - design cap(s)
  - draw valve(s)
  - prime plug

Remove all O-rings.

**Note:** To remove O-rings, use a single-service towel to grasp the O-ring. Apply pressure in an upward direction until the O-ring pops out of its groove. With the other hand, push the top of the O-ring forward and it will roll out of the groove and can be easily removed. If there is more than one O-ring to be removed, always remove the rear O-ring first. This will allow the O-ring to slide over the forward rings without falling into the open grooves.

4. Remove the O-rings from the air tube and air orifice (soft serve only).
5. Return to the freezer with a small amount of cleaning solution. Brush clean the rear shell bearing(s) at the back of the freezing cylinder(s) with the black bristle brush.

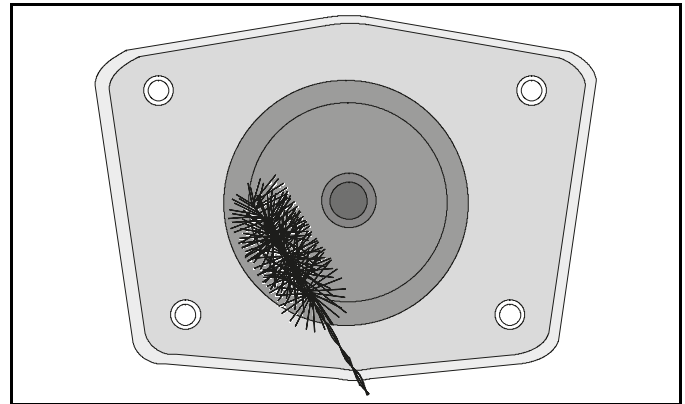

Figure 6-38

6. Remove the rear drip pan(s) and take to the sink for cleaning.
 

**Note:** If the drip pan is filled with an excessive amount of mix, refer to the Troubleshooting Guide.
7. Thoroughly brush clean all disassembled parts in the cleaning solution making sure all lubricant and mix film is removed. Take particular care to brush clean the draw valve core(s) in the freezer door. Place all the cleaned parts on a clean, dry surface to air dry overnight.
8. Wipe clean all exterior surfaces of the freezer.



## During Cleaning and Sanitizing



**ALWAYS FOLLOW LOCAL HEALTH CODES.**



**NOTICE!** Cleaning and sanitizing schedules are governed by your federal, state, or local regulatory agencies and must be followed accordingly. Please see the cleaning section of this manual for the proper procedure to clean this machine.

**Important!** Standby mode **must not** be used in lieu of proper cleaning and sanitizing procedures and frequencies set forth by the ruling health authority. The following checkpoints should be stressed during the cleaning and sanitizing operations:



**IMPORTANT!** Cleaning and sanitizing must be performed daily.

Cleaning and sanitizing schedules are governed by your State or local regulatory agencies and must be followed accordingly. The following checkpoints should be stressed during the cleaning and sanitizing operations.

## Troubleshooting Bacterial Count

- Thoroughly clean and sanitize the machine regularly, including complete disassembly and brush cleaning.
- Use all brushes supplied for thorough cleaning. The brushes are specially designed to reach all mix passageways.
- Use the white bristle brush to clean the mix inlet hole which extends from the mix hopper down to the rear of the freezing cylinder.
- Use the black bristle brush to thoroughly clean the rear shell bearing at the rear of the freezing cylinder. Make sure to have a generous amount of cleaning solution on the brush.
- If local health codes permit the use of rerun, make sure the rerun mix is stored in a sanitized, covered stainless steel container and used the following day. Do not prime the machine with rerun. When using rerun, skim off the foam and discard it. Mix the rerun with **fresh** mix in a ratio of 50/50 during the days operation.
- On a designated day of the week, run the mix as low as feasible and discard it after closing. This will break the rerun cycle and reduce the possibility of high bacteria and coliform counts.
- Properly prepare the cleaning and sanitizing solutions. Read and follow label directions carefully. Too **strong** of a solution may damage the parts and too **weak** of a solution will not do an adequate job of cleaning or sanitizing.
- The temperature of the mix in the mix hopper and walk-in cooler should be below 40°F (4.4°C.).

### Regular Maintenance Checks

- Replace scraper blades that are nicked or damaged. Before installing the beater assembly, make certain that scraper blades are properly attached to the helix or pins.
- Check the rear shell bearing for signs of wear (excessive mix leakage in rear drip pan) and be certain it is properly cleaned.
- Using a screwdriver and cloth towel, keep the rear shell bearing and the female drive socket clean and free of lubricant and mix deposits.
- Dispose of O-ring and seals if they are worn, torn, or fit too loosely, and replace with new ones.
- If your machine is air-cooled, check the condensers for accumulation of dirt and lint. Dirty condensers will reduce the efficiency and capacity of the machine. Condensers should be cleaned monthly with a soft brush. **Never** use screwdrivers or other metal probes to clean between the fins.
- Follow all lubricating procedures as outlined in: “Soft Serve Side Freezing Cylinder Assembly” on page 6-1, and “Shake Side Freezing Cylinder Assembly” on page 6-5.



**7** **WARNING!** Always disconnect electrical power prior to cleaning the condenser. Failure to follow this instruction may result in electrocution.

- If your machine is equipped with an auxiliary refrigeration system, check the auxiliary condenser for accumulation of dirt and lint. Dirty condensers will reduce the refrigeration capacity of the mix hopper. Condensers must be cleaned monthly with a soft brush. **Never** use screwdrivers or other metal probes to clean between the fins.

**Note:** For machines equipped with an air filter, it will be necessary to vacuum clean the filters on a monthly schedule.

- If your machine is water-cooled, check the water lines for kinks or leaks. Kinks can occur when the machine is moved back and forth for cleaning or maintenance purposes. Deteriorated or cracked water lines should be replaced only by an authorized Taylor service technician.

### Winter Storage

If the place of business is to be closed during the winter months, it is important to protect the freezer by following certain precautions, particularly if the building is subject to freezing conditions.

Disconnect the freezer from the main power source to prevent possible electrical damage.

On water-cooled freezers, disconnect the water supply. Relieve pressure on the spring in the water valve. Use air pressure on the outlet side to blow out any water remaining in the condenser. **This is extremely important.** Failure to follow this procedure may cause severe and costly damage to the refrigeration system.

Your local Taylor service technician can perform this winter storage service for you.

Wrap detachable parts of the freezer such as the beater, blades, drive shaft, and freezer door, and place them in a protected dry place. Rubber trim parts and gaskets can be protected by wrapping them with moisture-proof paper. All parts should be thoroughly cleaned of dried mix or lubrication, which attract mice and other vermin.

Table 8-1

Problem	Probable Cause	Remedy	Page Ref.
1. No product is being dispensed with draw valve open and the machine in the Auto mode.	a. Freeze-up in mix inlet hole.	a. Call a service technician to adjust the mix hopper temperature.	- - -
	b. Beater motor out on reset.	b. Reset the freezer.	5-2
	c. The beater is rotating counterclockwise from the operator end.	c. Contact a service technician to correct rotation to clockwise from operator end.	- - -
	d. The circuit breaker is off or the fuse is blown.	d. Turn the breaker on, or replace the fuse.	- - -
	e. There is inadequate mix in the mix hopper.	e. Fill the mix hopper with mix.	6-9
	f. The air orifice is not installed (soft serve only).	f. Install air orifice in air tube.	6-4
2. The product is too stiff.	a. The viscosity needs adjustment.	a. Contact a service technician.	- - -
	b. The air orifice is not installed (soft serve only).	b. Install air orifice in air tube.	6-4
3. The product is too soft.	a. The viscosity needs adjustment.	a. Contact a service technician.	- - -
	b. Not enough air space around machine. (Air-cooled machines.)	b. Allow for adequate air flow across the condenser.	1-2
	c. Worn scraper blades.	c. Replace regularly.	9-1
	d. Dirty condenser (Air-cooled machines.)	d. Clean monthly.	7-2
	e. Mix is out of date.	e. Use only fresh mix.	- - -
	f. Loss of water. (Water-cooled machines.)	f. Locate cause of water loss and correct.	7-2
4. The mix in the mix hopper is too cold.	a. The temperature is out of adjustment.	a. Call a service technician to adjust the mix hopper temperature.	- - -
5. The mix in the mix hopper is too warm.	a. The temperature is out of adjustment.	a. Call a service technician to adjust the mix hopper temperature.	- - -
	b. The mix hopper cover is not in position.	b. Place the cover in position.	- - -
	c. The MIX light is not lit.	c. Press the MIX key.	5-2
6. The drive shaft is stuck in the drive coupling.	a. Rounded corners of drive shaft, coupling, or both.	a. Call a service technician to correct cause, and to replace the necessary components. Do not lubricate the hex end of the drive shaft.	- - -
	b. Mix and lubricant collected in the drive coupling.	b. Brush clean the rear shell bearing area regularly.	6-11

## TROUBLESHOOTING GUIDE

Problem	Probable Cause	Remedy	Page Ref.
7. The freezing cylinder walls are scored.	a. Scraper blades and/or blade clips are damaged.	a. Replace scraper blades and/or clips.	6-5
	b. Missing or worn front bearing on freezer door.	b. Install or replace the front bearing.	6-2
	c. Machine was placed in Auto mode before all sanitizing solution was removed from freezing cylinder.	c. Place machine in Auto mode only after priming is complete and all sanitizing solution has been removed.	6-9 / 6-9
	d. The beater assembly is bent/damaged.	d. Call a service technician to repair or replace.	- - -
8. Excessive mix leakage into the rear drip pan.	a. Missing or worn drive shaft seal on drive shaft.	a. Install or replace regularly.	6-1 / 9-1
	b. The rear shell bearing is worn.	b. Call a service technician to replace rear shell bearing.	
9. Excessive mix leakage from door spout.	a. Missing or worn draw valve O-ring.	a. Install or replace regularly.	6-3 / 9-1
	b. Inadequate lubrication of draw valve O-ring.	b. Lubricate properly.	6-3
	c. Wrong type of lubricant is being used (example: petroleum-based lubricant).	c. Use the proper lubricant (example: Taylor Lube).	6-1
10.No freezer operation after pressing the AUTO key.	a. Machine is unplugged.	a. Plug into wall receptacle.	- - -
	b. The circuit breaker is off or the fuse is blown.	b. Turn the breaker on, or replace the fuse.	- - -
	c. The beater motor is out on reset.	c. Reset the freezer.	5-2
11.Product is not feeding into the freezing cylinder.	a. Inadequate level of mix in the mix hopper.	a. Fill the mix hopper with mix.	- - -
	b. The mix inlet hole is frozen up.	b. The mix hopper temperature needs adjustment. Call a service technician.	- - -
	c. The air tube is installed incorrectly.	c. Install the air tube in the mix inlet hole, using the end with the small hole in the side.	5-3
	d. The air orifice is not installed (soft serve).	d. Install the air orifice in the air tube.	6-4

# Section 9

# Parts Replacement Schedule

Table 9-1

Part Description	Every 3 Months	Every 6 Months	Annually
Drive Shaft Seal	X		
*Scraper Blade (Soft Serve)	X		
Freezer Door Gasket	X		
Front Bearing	X		
Draw Valve O-ring	X		
Pivot Pin O-ring	X		
Prime Plug O-ring	X		
Air Tube O-ring	X		
Air Orifice O-ring	X		
White Bristle Brush, 3" x 7"		Inspect and replace if necessary.	Minimum
White Bristle Brush, 1" x 2"		Inspect and replace if necessary.	Minimum
Black Bristle Brush, 1" x 2"		inspect and replace if necessary.	Minimum
Double-Ended Brush		Inspect and replace if necessary.	Minimum

\*Shake scraper blade replacement is every 4 months.



## TAYLOR COMPANY LIMITED WARRANTY ON FREEZERS

Taylor Company is pleased to provide this limited warranty on new Taylor-branded freezer equipment available from Taylor to the market generally (the "Product") to the original purchaser only.

### LIMITED WARRANTY

Taylor warrants the Product against failure due to defect in materials or workmanship under normal use and service as follows. All warranty periods begin on the date of original Product installation. If a part fails due to defect during the applicable warranty period, Taylor, through an authorized Taylor distributor or service agency, will provide a new or remanufactured part, at Taylor's option, to replace the failed defective part at no charge for the part. Except as otherwise stated herein, these are Taylor's exclusive obligations under this limited warranty for a Product failure. This limited warranty is subject to all provisions, conditions, limitations and exclusions listed below and on the reverse (if any) of this document.

Table 10-1

Product	Part	Limited Warranty Period
<b>Soft Serve</b>	Insulated shell assembly	Five (5) years
<b>Frozen Yogurt Shakes</b>	Refrigeration compressor (except service valve)	Five (5) years
<b>Smoothies</b>	Beater motors	Two (2) years
<b>Frozen Beverage</b>	Beater drive gear	Two (2) years
<b>Batch Desserts</b>	Printed circuit boards and Softech™ controls beginning with serial number H8024200	Two (2) years
	Parts not otherwise listed in this table or excluded below	One (1) years

### LIMITED WARRANTY CONDITIONS

1. If the date of original installation of the Product cannot be verified, then the limited warranty period begins ninety (90) days from the date of Product manufacture (as indicated by the Product serial number). Proof of purchase may be required at time of service.
2. This limited warranty is valid only if the Product is installed and all required service work on the Product is performed by an authorized Taylor distributor or service agency, and only if genuine, new Taylor parts are used.
3. Installation, use, care, and maintenance must be normal and in accordance with all instructions contained in the Taylor Operator's Manual.
4. Defective parts must be returned to the authorized Taylor distributor or service agency for credit.
5. The use of any refrigerant other than that specified on the Product's data label will void this limited warranty.

### LIMITED WARRANTY EXCEPTIONS

This limited warranty does **not** cover:

1. Labor or other costs incurred for diagnosing, repairing, removing, installing, shipping, servicing, or handling of defective parts, replacement parts, or new Products.
2. Normal maintenance, cleaning and lubrication as outlined in the Taylor Operator's Manual, including cleaning of condensers.

## LIMITED WARRANTY ON EQUIPMENT

---

3. Replacement of wear items designated as Class "000" parts in the Taylor Operator's Manual.
4. External hoses, electrical power supplies, and machine grounding.
5. Parts not supplied or designated by Taylor, or damages resulting from their use.
6. Return trips or waiting time required because a service technician is prevented from beginning warranty service work promptly upon arrival.
7. Failure, damage or repairs due to faulty installation, misapplication, abuse, no or improper servicing, unauthorized alteration or improper operation or use as indicated in the Taylor Operator's Manual, including but not limited to the failure to use proper assembly and cleaning techniques, tools, or approved cleaning supplies.
8. Failure, damage or repairs due to theft, vandalism, wind, rain, flood, high water, water, lightning, earthquake or any other natural disaster, fire, corrosive environments, insect or rodent infestation, or other casualty, accident or condition beyond the reasonable control of Taylor; operation above or below the electrical or water supply specification of the Product; or components repaired or altered in any way so as, in the judgment of the Manufacturer, to adversely affect performance, or normal wear or deterioration.
9. Any Product purchased over the Internet.
10. Failure to start due to voltage conditions, blown fuses, open circuit breakers, or damages due to the inadequacy or interruption of electrical service.
11. Electricity or fuel costs, or increases in electricity or fuel costs from any reason whatsoever.
12. Damages resulting from the use of any refrigerant other than that specified on the Product's data label will void this limited warranty.
13. Any cost to replace, refill or dispose of refrigerant, including the cost of refrigerant.
14. **ANY SPECIAL, INDIRECT OR CONSEQUENTIAL PROPERTY OR COMMERCIAL DAMAGE OF ANY NATURE WHATSOEVER.** Some jurisdictions do not allow the exclusion of incidental or consequential damages, so this limitation may not apply to you.

This limited warranty gives you specific legal rights, and you may also have other rights which vary from jurisdiction to jurisdiction.

### LIMITATION OF WARRANTY

**THIS LIMITED WARRANTY IS EXCLUSIVE AND IS IN LIEU OF ALL OTHER WARRANTIES, CONDITIONS AND/OR REMEDIES UNDER THE LAW, INCLUDING ANY IMPLIED WARRANTIES OR CONDITIONS OF MERCHANTABILITY OR FITNESS FOR A PARTICULAR PURPOSE. THE ORIGINAL OWNER'S SOLE REMEDY WITH RESPECT TO ANY PRODUCTS SHALL BE REPAIR OR REPLACEMENT OF DEFECTIVE COMPONENTS UNDER THE TERMS OF THIS LIMITED WARRANTY. ALL RIGHTS TO CONSEQUENTIAL OR INCIDENTAL DAMAGES (INCLUDING CLAIMS FOR LOST SALES, LOST PROFITS, PRODUCT LOSS, PROPERTY DAMAGES OR SERVICE EXPENSES) ARE EXPRESSLY EXCLUDED. THE EXPRESS WARRANTIES MADE IN THIS LIMITED WARRANTY MAY NOT BE ALTERED, ENLARGED, OR CHANGED BY ANY DISTRIBUTOR, DEALER, OR OTHER PERSON, WHATSOEVER.**

### LEGAL REMEDIES

The owner **must** notify Taylor in writing, by certified or registered letter to the following address, of any defect or complaint with the Product, stating the defect or complaint and a specific request for repair, replacement, or other correction of the Product under warranty, mailed at least thirty (30) days before pursuing any legal rights or remedies..

Taylor Company  
750 N. Blackhawk Blvd.  
Rockton, IL 61072, U.S.A.

## TAYLOR COMPANY LIMITED WARRANTY ON GENUINE TAYLOR PARTS

Taylor Company is pleased to provide this limited warranty on new Taylor genuine replacement components and parts available from Taylor to the market generally (the "Parts") to the original purchaser only.

### LIMITED WARRANTY

Taylor warrants the Parts against failure due to defect in materials or workmanship under normal use and service as follows. All warranty periods begin on the date of original installation of the Part in the Taylor unit. If a Part fails due to defect during the applicable warranty period, Taylor, through an authorized Taylor distributor or service agency, will provide a new or remanufactured Part, at Taylor's option, to replace the failed defective Part at no charge for the Part. Except as otherwise stated herein, these are Taylor's exclusive obligations under this limited warranty for a Part failure. This limited warranty is subject to all provisions, conditions, limitations and exclusions listed below and on the reverse (if any) of this document.

Table 11-1

Part's Warranty Class Code or Part	Limited Warranty Period
Class 103 Parts <sup>1</sup>	Three (3) Months
Class 212 Parts <sup>2</sup>	Twelve (12) Months
Class 512 Parts	Twelve (12) Months
Class 000 Parts	No Warranty

### LIMITED WARRANTY CONDITIONS

1. If the date of original installation of the Part cannot be otherwise verified, proof of purchase may be required at time of service.
2. This limited warranty is valid only if the Part is installed and all required service work in connection with the Part is performed by an authorized Taylor distributor or service agency.
3. The limited warranty applies only to Parts remaining in use by their original owner at their original installation location in the unit of original installation.
4. Installation, use, care, and maintenance must be normal and in accordance with all instructions contained in the Taylor Operator's Manual.
5. Defective Parts must be returned to the authorized Taylor distributor or service agency for credit.
6. This warranty is not intended to shorten the length of any warranty coverage provided pursuant to a separate Taylor Limited Warranty on freezer or grill equipment.
7. The use of any refrigerant other than that specified for the unit in which the Part is installed will void this limited warranty.

<sup>1, 2</sup> Except that Taylor part no. [032129SER2](#) (Compressor-Air-230V SERV) and Taylor part no. [075506SER1](#) (Compressor-Air-115V 60HZ) shall have a limited warranty period of twelve (12) months when used in Taylor freezer equipment and a limited warranty period of two (2) years when used in Taylor grill equipment.

## LIMITED WARRANTY ON PARTS

---

### LIMITED WARRANTY EXCEPTIONS

This limited warranty does **not** cover:

1. Labor or other costs incurred for diagnosing, repairing, removing, installing, shipping, servicing, or handling of defective Parts, replacement Parts, or new Parts.
2. Normal maintenance, cleaning and lubrication as outlined in the Taylor Operator's Manual, including cleaning of condensers or carbon and grease buildup.
3. Required service, whether cleaning or general repairs, to return the cooking surface assemblies, including the upper platen and lower plate, to an operational condition to achieve proper cooking or allow proper assembly of release sheets and clips as a result of grease build-up on the cooking surfaces, including but not limited to the platen and plate, sides of the shroud or top of the shroud.
4. Replacement of cooking surfaces, including the upper platen and lower plate, due to pitting or corrosion (or in the case of the upper platen, due to loss of plating) as a result of damage due to the impact of spatulas or other small wares used during the cooking process or as a result of the use of cleaners, cleaning materials or cleaning processes not approved for use by Taylor.
5. Replacement of wear items designated as Class "000" Parts in the Taylor Operator's Manual, as well as any release sheets and clips for the Product's upper platen assembly.
6. External hoses, electrical power supplies, and machine grounding.
7. Parts not supplied or designated by Taylor, or damages resulting from their use.
8. Return trips or waiting time required because a service technician is prevented from beginning warranty service work promptly upon arrival.
9. Failure, damage or repairs due to faulty installation, misapplication, abuse, no or improper servicing, unauthorized alteration or improper operation or use as indicated in the Taylor Operator's Manual, including but not limited to the failure to use proper assembly and cleaning techniques, tools, or approved cleaning supplies.
10. Failure, damage, or repairs due to theft, vandalism, wind, rain, flood, high water, water, lightning, earthquake or any other natural disaster, fire, corrosive environments, insect or rodent infestation, or other casualty, accident or condition beyond the reasonable control of Taylor; operation above or below the gas, electrical or water supply specification of the unit in which a part is installed; or Parts or the units in which they are installed repaired or altered in any way so as, in the judgment of Taylor, to adversely affect performance, or normal wear or deterioration.
11. Any Part purchased over the Internet.
12. Failure to start due to voltage conditions, blown fuses, open circuit breakers, or damages due to the inadequacy or interruption of electrical service.
13. Electricity, gas or other fuel costs, or increases in electricity or fuel costs from any reason whatsoever.
14. Damages resulting from the use of any refrigerant other than that specified for the unit in which the Part is installed will void this limited warranty.
15. Any cost to replace, refill or dispose of refrigerant, including the cost of refrigerant.
16. **ANY SPECIAL, INDIRECT OR CONSEQUENTIAL PROPERTY OR COMMERCIAL DAMAGE OF ANY NATURE WHATSOEVER.** Some jurisdictions do not allow the exclusion of incidental or consequential damages, so this limitation may not apply to you.

This limited warranty gives you specific legal rights, and you may also have other rights which vary from jurisdiction to jurisdiction.

**LIMITATION OF WARRANTY**

**THIS LIMITED WARRANTY IS EXCLUSIVE AND IS IN LIEU OF ALL OTHER WARRANTIES, CONDITIONS AND/ OR REMEDIES UNDER THE LAW, INCLUDING ANY IMPLIED WARRANTIES OR CONDITIONS OF MERCHANTABILITY OR FITNESS FOR A PARTICULAR PURPOSE. THE ORIGINAL OWNER'S SOLE REMEDY WITH RESPECT TO ANY PRODUCTS SHALL BE REPAIR OR REPLACEMENT OF DEFECTIVE PARTS UNDER THE TERMS OF THIS LIMITED WARRANTY. ALL RIGHTS TO CONSEQUENTIAL OR INCIDENTAL DAMAGES (INCLUDING CLAIMS FOR LOST SALES, LOST PROFITS, PRODUCT LOSS, PROPERTY DAMAGES OR SERVICE EXPENSES) ARE EXPRESSLY EXCLUDED. THE EXPRESS WARRANTIES MADE IN THIS LIMITED WARRANTY MAY NOT BE ALTERED, ENLARGED, OR CHANGED BY ANY DISTRIBUTOR, DEALER, OR OTHER PERSON, WHATSOEVER.**

**LEGAL REMEDIES**

The owner **must** notify Taylor in writing by certified or registered letter to the following address of any defect or complaint with the Part, stating the defect or complaint and a specific request for repair, replacement, or other correction of the Part under warranty, mailed at least thirty (30) days before pursuing any legal rights or remedies.

Taylor Company  
750 N. Blackhawk Blvd.  
Rockton, IL 61072, U.S.A.

