

OPERATOR'S MANUAL



**Model 750, 751, 754, 774,
791, and 794 Soft Serve Freezer**

Original Operating Instructions

028754-M

2/01/2002 (Original Publication)
(Updated 10/14/2020)

Table of Contents

Section 1: To the Installer

- Installer Safety 1-1
- Site Preparation 1-1
- Air-Cooled Machines..... 1-1
- Water Connections..... 1-2
- Electrical Connections..... 1-2
- Beater Rotation 1-3
- Refrigerant 1-3

Section 2: To the Operator

- Compressor Warranty Disclaimer 2-2

Section 3: Safety

Section 4: Operator Parts Identification

- Model 750 4-1
- Model 751 4-2
- Model 754 4-3
- Model 774 4-4
- Model 774 Topping Pump (053794-) 4-5
- Model 791 4-6
- Model 794 4-7
- Models 750 and 751 Single-Spout Door and Beater Assembly 4-8
- Models 754, 774 and 794 Three-Spout Door and Beater Assembly..... 4-9
- Model 791 Three-Spout Door and Beater Assembly 4-10
- Accessories..... 4-11

Section 5: User Interface

- 750/751 5-1
- 754/774/791/794 5-1
- Symbol Definitions 5-2
- Power Switch 5-2
- MIX LOW Indicator Light..... 5-2

MIX Refrigeration Button	5-2
STANDBY Button	5-2
WASH Button	5-2
AUTO Button	5-3
RESET Button	5-3
Air Tube	5-3
Adjustable Draw Handle	5-4

Section 6: Operating Procedures

Prior to Setup (Model 774)	6-1
Assembly	6-1
Sanitizing	6-6
Priming	6-8
Closing Procedure	6-9
Draining Product from the Freezing Cylinder	6-9
Rinsing	6-9
Cleaning	6-9
Disassembly	6-9
Manual Brush-Cleaning	6-10

Section 7: Operator’s Checklist

During Cleaning and Sanitizing	7-1
Troubleshooting Bacterial Count	7-1
Regular Maintenance Checks	7-1
Winter Storage	7-2

Section 8: Troubleshooting Guide

Section 9: Parts Replacement Schedule

Maintenance Intervals	9-1
-----------------------------	-----

Section 10: Limited Warranty on Equipment

Section 11: Limited Warranty on Parts

The following information has been included in the manual as safety and regulatory guidelines. For complete installation instructions, please see the Operator's Checklist.

Installer Safety



IMPORTANT! In all areas of the world, machines should be installed in accordance with existing local codes. Please contact your local authorities if you have any questions.

Care should be taken to ensure that all basic safety practices are followed during the installation and servicing activities related to the installation and service of Taylor® machines.

- Only Taylor service personnel should perform installation, maintenance, and repairs on Taylor machines.
- Authorized service personnel should consult OSHA Standard 29CFR1910.147 or the applicable code of the local area for industry standards on lockout/tagout procedures before beginning any installation or repairs.
- Authorized service personnel must ensure that the proper personal protective equipment (PPE) is available and worn when required during installation and service.
- Authorized service personnel must remove all metal jewelry, rings, and watches before working on electrical equipment.



DANGER! The main power supply(s) to the machine must be disconnected prior to performing any installation, maintenance, or repairs. **For Cord-Connected Machines:** Only authorized Taylor service technicians or licensed electricians may install a plug or replacement cord on the machine. Failure to follow this instruction may result in personal injury or death from electrical shock or hazardous moving parts, as well as poor performance or damage to the machine.

Note: All repairs must be performed by a Taylor service technician.



WARNING! This machine has many sharp edges that can cause severe injuries.

1

Site Preparation

Review the area the machine is to be installed in before uncrating the machine, making sure that all possible hazards regarding the user or equipment have been addressed.

Air-Cooled Machines

Do not obstruct air intake and discharge openings:

Counter Model: 6 in. (152 mm) minimum airspace on both sides and 0 in. (0.0 mm) on the rear.

Console Models: 3 in. (76 mm) minimum airspace on all sides.

This will allow for adequate airflow across the condenser(s). Failure to allow adequate clearance can reduce the refrigeration capacity of the freezer and possibly cause permanent damage to the compressor.

For Indoor Use Only: This machine is designed to operate indoors, under normal ambient temperatures of 70°F to 75°F (21°C to 24°C). The freezer has successfully performed in high ambient temperatures of 104°F (40°C) at reduced capacities.



WARNING! This machine must **NOT** be installed in an area where a water jet or hose can be used. **NEVER** use a water jet or hose to rinse or clean the machine. Failure to follow this instruction may result in electrocution.



CAUTION! This machine must be installed on a level surface to avoid the hazard of tipping. Extreme care should be taken in moving this machine for any reason. Two or more persons are required to safely move this machine. Failure to comply may result in personal

injury or damage to the machine.

The authorized installer should inspect the machine and promptly report any damage to the local authorized Taylor distributor.

This machine is made using USA sizes of hardware. All metric conversions are approximate and vary in size.

1

Water Connections

(Water-Cooled Machines Only)

An adequate cold water supply must be provided with a hand shutoff valve. On the underside rear of the base pan, two 3/8 in. IPS (for single-head units) or two 1/2 in. IPS (for double-head units) water connections for inlet and outlet have been provided for easy hookup. Permanently connect the machine using 1/2 in. (12.7 mm) inside diameter water lines. (Flexible lines are recommended, if local codes permit.) Depending on local water conditions, it may be advisable to install a water strainer to prevent foreign substances from clogging the automatic water valve. There will be only one **water-in** and one **water-out** connection for both single-head and double-head units. **Do not** install a hand shutoff valve on the **water-out** line! Water should always flow in this order: first, through the automatic water valve; second, through the condenser; and third, through the outlet fitting to an **open trap drain**.



IMPORTANT! A backflow prevention device is required on the incoming water connection side. Please see the applicable national, state, and local codes for determining the proper configuration. Water pressure to the unit must not exceed 150 psi (1034 kPa).

Electrical Connections

In the United States, this machine is intended to be installed in accordance with the National Electrical Code (NEC) ANSI/NFPA 70-1987. The purpose of the NEC code is the practical safeguarding of persons and property from hazards arising from the use of electricity. This code contains provisions considered necessary for safety. In all other areas of the world, machines should be installed in accordance with the existing local codes. Please contact your local authorities.



FOLLOW YOUR LOCAL ELECTRICAL CODES.

Each machine requires one power supply for each data label on the machine. Check the data label(s) on the freezer for branch circuit overcurrent protection or fuse, circuit ampacity, and other electrical specifications. See the wiring diagram provided inside the electrical box for proper power connections.



WARNING! This machine must be properly grounded. Failure to do so can result in severe personal injury from electrical shock.



WARNING! DO NOT operate this freezer with fuses larger than specified on the machine data label. Failure to follow this instruction may result in electrocution or damage to the machine.



IMPORTANT! An equipotential grounding lug is provided with this machine. Some countries require the grounding lug to be properly attached to the rear of the frame by the authorized installer. The installation location is marked by the equipotential bonding symbol (5021 of IEC 60417-1) on both the removable panel and the machine's frame.



IMPORTANT!

- Stationary machines which are not equipped with a power cord and a plug or another device to disconnect the machine from the power source must have an all-pole disconnecting

device with a contact gap of at least 0.125 in. (3 mm) in the external installation.

- Machines that are permanently connected to fixed wiring and for which leakage currents may exceed 10 mA, particularly when disconnected or not used for long periods, or during initial installation, shall have protective devices to protect against the leakage of current, such as a GFI, installed by authorized personnel to local codes.
- Supply cords used with this machine shall be oil-resistant, sheathed flexible cable not lighter than ordinary polychloroprene or other equivalent synthetic elastomer-sheathed cord (code designation 60245 IEC 57) installed with the proper cord anchorage to relieve conductors from strain, including twisting, at the terminals and protect the insulation of the conductors from abrasion.

If the supply cord is damaged, it must be replaced by a Taylor service technician to avoid a hazard. Secure the supply cord ground lead to the machine in a location where if the cord is pulled the main power leads will become taut before the ground lead can break loose.

Beater Rotation



NOTICE! Beater rotation must be clockwise as viewed looking into the freezing cylinder.

To correct the rotation on a three-phase machine, interchange any two incoming power supply lines at the freezer main terminal block only. To correct rotation on a single-phase machine, exchange leads inside the beater motor. (Follow the diagram printed on the motor.)

Electrical connections are made directly to the terminal block provided in the main control box, located behind the service panel.

It is recommended that beater rotation adjustment be performed by a Taylor service technician.

Refrigerant



CAUTION! This machine contains fluorinated greenhouse gases (F-Gas) to provide refrigeration using a hermetically sealed circuit or within foam insulation. This machine's type of gas, quantity, Global Warming Potential (GWP), and CO₂ tonnes equivalent information is recorded on the machine's data label. The refrigerant used is generally considered nontoxic and nonflammable. However any gas under pressure is potentially hazardous and must be handled with caution.

NEVER fill any refrigerant cylinder completely with liquid. Filling the cylinder approximately 80% will allow for normal expansion.



CAUTION! Use only approved refrigerant listed on the machine's data label or authorized through a manufacturer's technical bulletin. The use of any other refrigerant may expose users and operators to unexpected safety hazards.



WARNING! Refrigerant liquid sprayed onto the skin may cause serious damage to tissue. Keep eyes and skin protected. If refrigerant burns should occur, flush the area immediately with cold water. If burns are severe, apply ice packs and contact a physician immediately.



NOTICE! Taylor reminds technicians to be aware of and in compliance with local government laws regarding refrigerant recovery, recycling, and reclaiming systems. For information regarding applicable local laws, please contact your local authorized Taylor distributor.



IMPORTANT! Refrigerants and their associated lubricants may be extremely moisture absorbent. When opening a refrigeration system, the maximum time the system is open must not exceed 15 minutes. Cap all open tubing to prevent humid air or water from being absorbed by the oil.

The freezer you have purchased has been carefully engineered and manufactured to give you dependable operation. The Taylor soft serve models covered in this manual are the following: 750, 751, 754, 774, 791, and 794.

These machines, when properly operated and cared for, will produce a consistent quality product. Like all mechanical products, they will require cleaning and maintenance. A minimum amount of care and attention is necessary if the operating procedures outlined in this manual are followed closely.



IMPORTANT! This manual should be read before operating or performing any maintenance on the machine.

Your Taylor machine will **NOT** compensate for and/or correct any errors made during setup or filling operations. Thus, the initial assembly, setup, and priming procedures are of extreme importance. It is strongly recommended that all personnel responsible for the machine's operation, including assembly and disassembly, go through these procedures together to be properly trained and to make sure that all personnel understand their role in using and maintaining the machine.

If you require technical assistance, please contact your local authorized Taylor distributor.

Note: Your Taylor warranty is valid only if the parts are authorized Taylor parts purchased from the local authorized Taylor distributor, and only if all required service work is provided by a Taylor service technician. Taylor reserves the right to deny warranty claims on machines or parts if unapproved parts or incorrect refrigerant were installed in the machine, system modifications were performed beyond factory recommendations, or it is determined that the failure was caused by abuse, misuse, neglect, or failure to follow all operating instructions. For full details of your Taylor warranty, please see the Limited Warranty section in this manual.

Note: Constant research results in steady improvements; therefore, information in this manual is subject to change without notice.



IMPORTANT! If the crossed-out wheeled bin symbol is affixed to this machine, it signifies that this machine is compliant with the EU directives as well as other similar end-of-life legislation in effect after August 13, 2005. Therefore, it must be collected separately after its use is completed and cannot be disposed as unsorted municipal waste.

The user is responsible for delivering the machine to the appropriate collection facility as specified by your local code.

For additional information regarding applicable local disposal laws, please contact the municipal waste facility and/or local authorized Taylor distributor.

For additional information regarding applicable local laws, please contact the municipal facility and/or local distributor.

Compressor Warranty Disclaimer

The refrigeration compressor(s) on this machine are warranted for the term stated in the Limited Warranty section in this manual. However, due to the Montreal Protocol and the U.S. Clean Air Act Amendments of 1990, many new refrigerants are being tested and developed, thus seeking their way into the service industry. Some of these new refrigerants are being advertised as drop-in replacements for numerous applications. It should be noted that in the event of ordinary service to this machine's refrigeration system, **only the refrigerant specified on the affixed data label should be used.** The unauthorized use of alternate refrigerants will void your Taylor compressor warranty. It is the machine owner's responsibility to make this fact known to any technician he/she employs.

It should also be noted that Taylor does not warrant the refrigerant used in its equipment. For example, if the refrigerant is lost during the course of ordinary service to this machine, Taylor has no obligation to either supply or provide its replacement either at billable or unbillable terms. Taylor does have the obligation to recommend a suitable replacement if the original refrigerant is banned, obsoleted, or no longer available during the 5-year warranty of the compressor.

The Taylor Company will continue to monitor the industry and test new alternates as they are being developed. Should a new alternate prove, through our testing, that it would be accepted as a drop-in replacement, the above disclaimer would become null and void. To find out the current status of an alternate refrigerant as it relates to your compressor warranty, call the local Taylor distributor or the Taylor factory. Be prepared to provide the model/serial number of the machine in question.

We at the Taylor Company are concerned about the safety of the operator when he or she comes into contact with the freezer and its parts. Taylor has gone to extreme efforts to design and manufacture built-in safety features to protect both you and the service technician. As an example, warning labels have been attached to the freezer to further point out safety precautions to the operator.



IMPORTANT! *This machine is to be used only by trained personnel. It is not intended for use, cleaning, or maintenance by children or people with reduced physical, sensory, or mental capabilities or lack of experience and knowledge, unless given supervision or instruction concerning the use of the machine by a person responsible for their safety. Children should be supervised to ensure that they do not play with the machine.*



WARNING! This machine must **NOT** be installed in an area where a water jet or hose can be used. **NEVER** use a water jet or hose to rinse or clean the machine. Failure to follow this instruction may result in electrocution.



IMPORTANT! *An equipotential grounding lug is provided with this machine. Some countries require the grounding lug to be properly attached to the rear of the frame by the authorized installer. The installation location is marked by the equipotential bonding symbol (5021 of IEC 60417-1) on both the removable panel and the machine's frame.*



WARNING! Avoid injury.

- **DO NOT** operate the machine unless it is properly grounded.
- **DO NOT** operate machine with fuses larger than specified on the data label.
- All repairs must be performed by a Taylor service technician.
- The main power supplies to the machine must be disconnected prior to performing repairs.
- **For Cord-Connected Machines:** Only Taylor service technicians or licensed electricians may install a plug or replacement cord on the machine.
- Stationary machine that are not equipped with a power cord and a plug or another device to disconnect the machine from the power source must have an all-pole disconnecting device with a contact gap of at least 0.125 in. (3 mm) in the external installation.
- Machines that are permanently connected to fixed wiring and for which leakage currents may exceed 10 mA, particularly when disconnected or not used for long periods, or during initial installation, shall have protective devices to protect against the leakage of current, such as a GFI, installed by authorized personnel to local codes.
- Supply cords used with this machine shall be oil-resistant, sheathed flexible cable not lighter than ordinary polychloroprene or other equivalent synthetic elastomer-sheathed cord (code designation 60245 IEC 57) installed with the proper cord anchorage to relieve conductors from strain, including twisting, at the terminals and protect the insulation of the conductors from abrasion.
- If the supply cord is damaged, it must be replaced by the manufacturer, service agent, or a similarly qualified person to avoid a hazard. Secure the supply cord ground lead to the machine in a location where if the cord is pulled the main power leads will become taut before the ground lead can break loose.



WARNING! Avoid injury.

- **DO NOT** allow untrained personnel to operate this machine.
- **DO NOT** put objects or fingers in the door spout.
- **DO NOT** operate the machine unless all service panels and access doors are fastened with screws.
- **DO NOT** remove the machine door or beater assembly unless the control switches are in the OFF position.

Failure to follow these instructions may result in contaminated product or severe personal injury to fingers or hands from hazardous moving parts.

3



WARNING! This machine has many sharp edges that can cause severe injuries.

- **DO NOT** put objects or fingers in the door spout. This may contaminate the product and cause severe personal injury from blade contact.
- **USE EXTREME CAUTION** when removing the beater assembly. The scraper blades are very sharp.

Failure to follow these instructions may result in electrocution or damage to the machine. Contact your local authorized Taylor distributor for service.



CAUTION! This machine must be placed on a level surface. Failure to comply may result in personal injury or machine damage.



NOTICE! Cleaning and sanitizing schedules are governed by your federal, state, or local regulatory agencies and must be followed accordingly. Please see the cleaning section of this manual for the proper procedure to clean this machine.



WARNING! Only install this machine in a location where its use and maintenance is restricted to trained personnel. Failure to comply may result in personal injury.

Do not run the machine without product. Failure to follow this instruction can result in damage to the machine.

Do not obstruct air intake and discharge openings:

Counter Model: 6 in. (152 mm) minimum airspace on both sides and 0 in. on the rear.

Console Models: 3 in. (76 mm) minimum airspace on all sides.

Failure to follow this instruction may cause poor freezer performance and damage to the machine.

These freezers are designed to operate indoors, under normal ambient temperatures of 70°F to 75°F (21°C to 24°C). The freezers have successfully performed in high ambient temperatures of 104°F (40°C) at reduced capacities.

Noise Level: Airborne noise emission does not exceed 78 dB (A) when measured at a distance of 39 in. (1.0 m) from the surface of the machine and at a height of 62 in. (1.6 m) from the floor.

Model 750

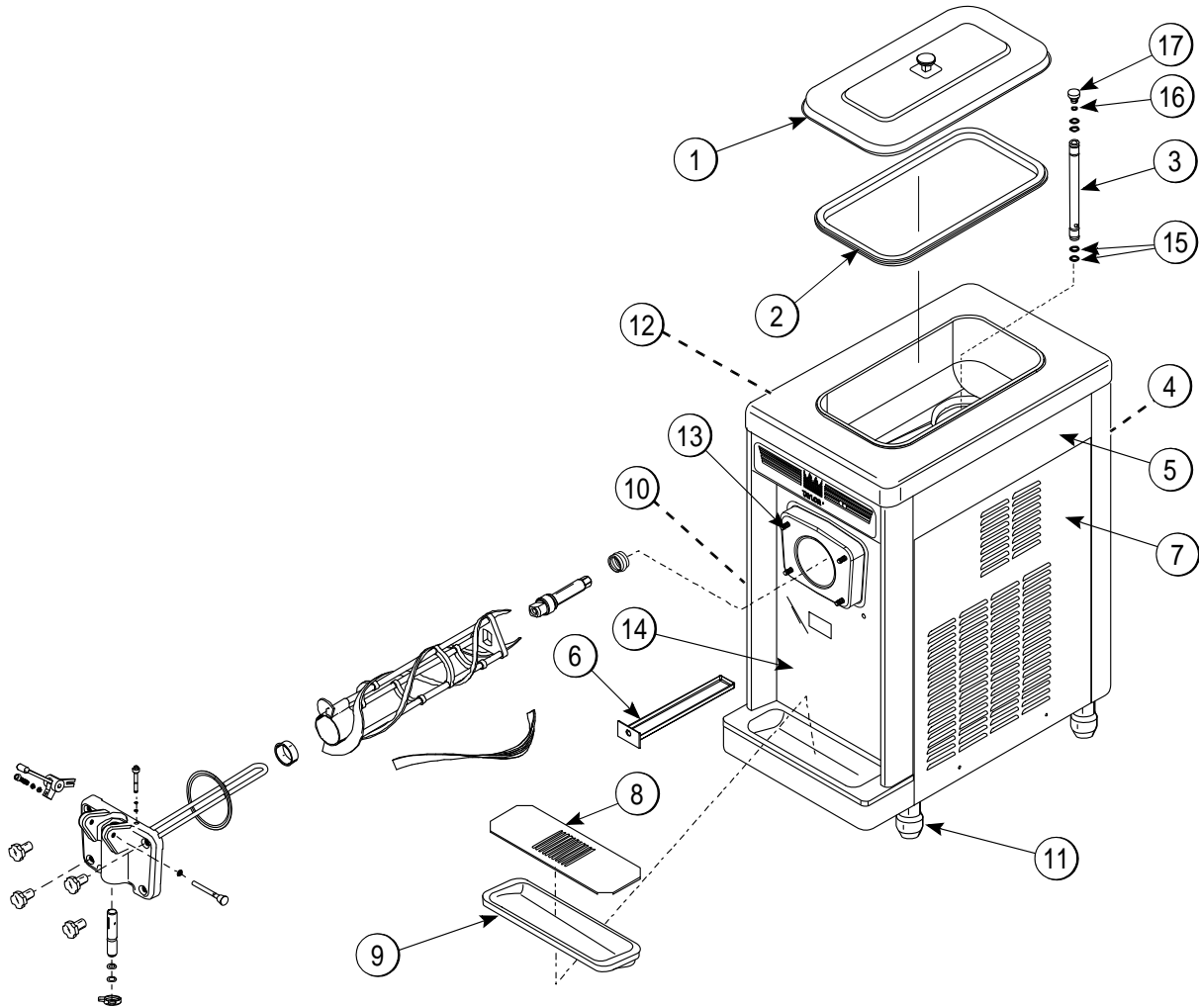

Figure 4-1

Item	Description	Part No.
1	Cover A.-Hopper	X38458-SER
2	Gasket-Hopper Cover	038375
3	Tube A.-Feed	X29429-2
4	Panel-Rear	020891
5	Panel-Upper Side Right	042317
6	Pan-Drip	050766
7	Panel-Right Side	050742
8	Shield-Splash	022763
9	Tray-Drip	013690

Item	Description	Part No.
10	Panel-Side Left	050741
11	Leg-4" SS w/O-ring	013458
12	Louver-Side	051192
13	Stud-Nose Cone	022822
14	Panel A.-Front	X50754
15	O-ring-.643 OD x .077 W	018572
16	O-ring-3/8 OD x .070 W	016137
17	Orifice	022465-100

Model 751

4

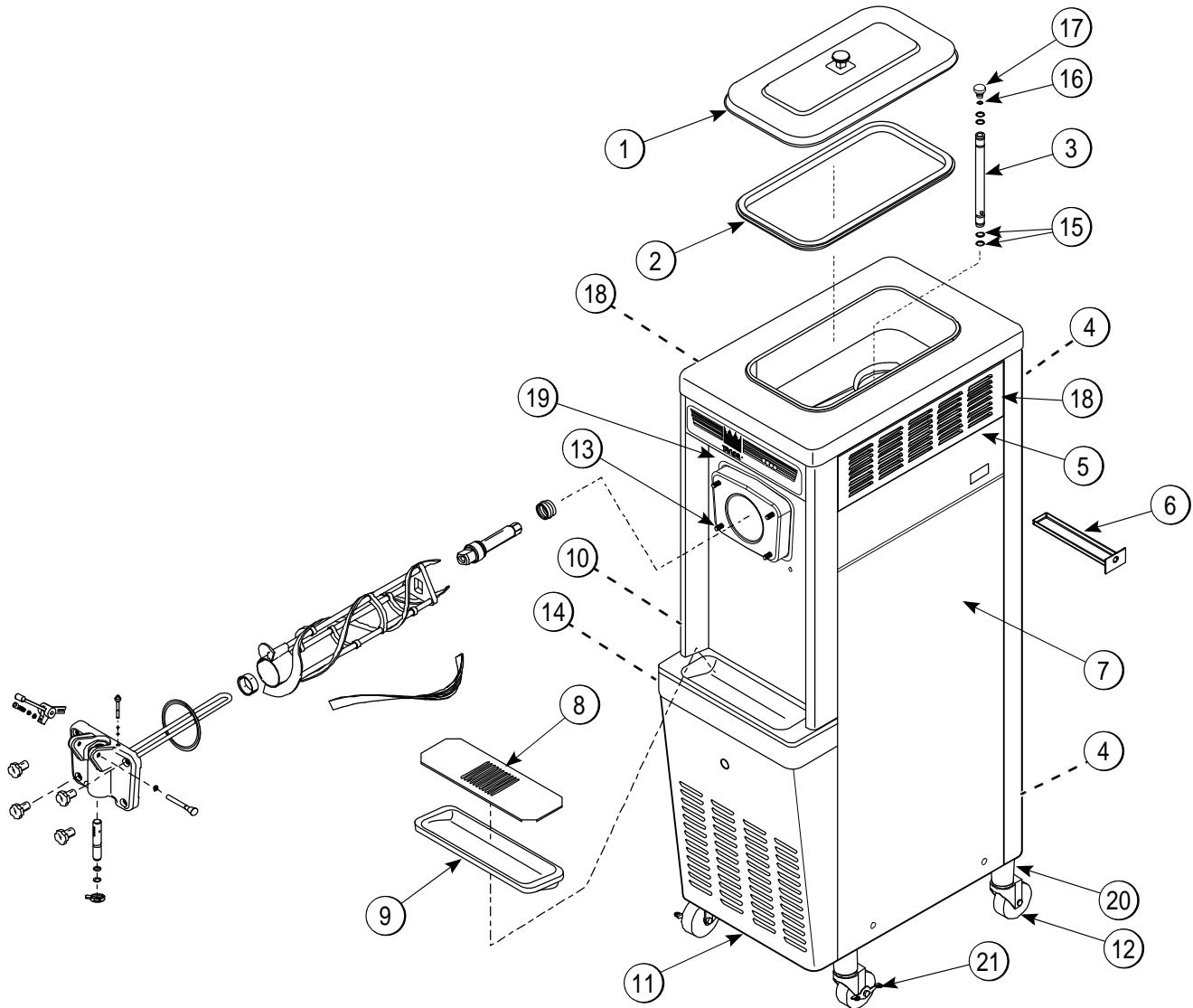

Figure 4-2

Item	Description	Part No.
1	Cover A.-Hopper	X38458-SER
2	Gasket-Hopper Cover	038375
3	Tube A.-Feed	X29429-2
4	Panel-Rear	013637
5	Panel-Upper Side Right	028823
6	Pan-Drip 11-5/8 Long	027503
7	Panel A.-Lower Side Right	X24424-SER
8	Shield-Splash	022763
9	Tray-Drip 14-7/8 x 5-1/8	013690
10	Panel-Upper Side	024426
11	Panel-Service	047170

Item	Description	Part No.
12	Caster-Swivel	018794
13	Stud-Nose Cone	022822
14	Panel A.-Side-Lower	X39075-SER
15	O-ring-.643 OD x .077 W	018572
16	O-ring-3/8 OD x .070 W	016137
17	Orifice	022465-100
18	Louver-Side-Top	051191
19	Panel A.-Front	X33237
20	Adaptor A.-Caster	X18915
21	Caster-4 Swivel 5/8" Stem w/ Brake	034081

Model 754

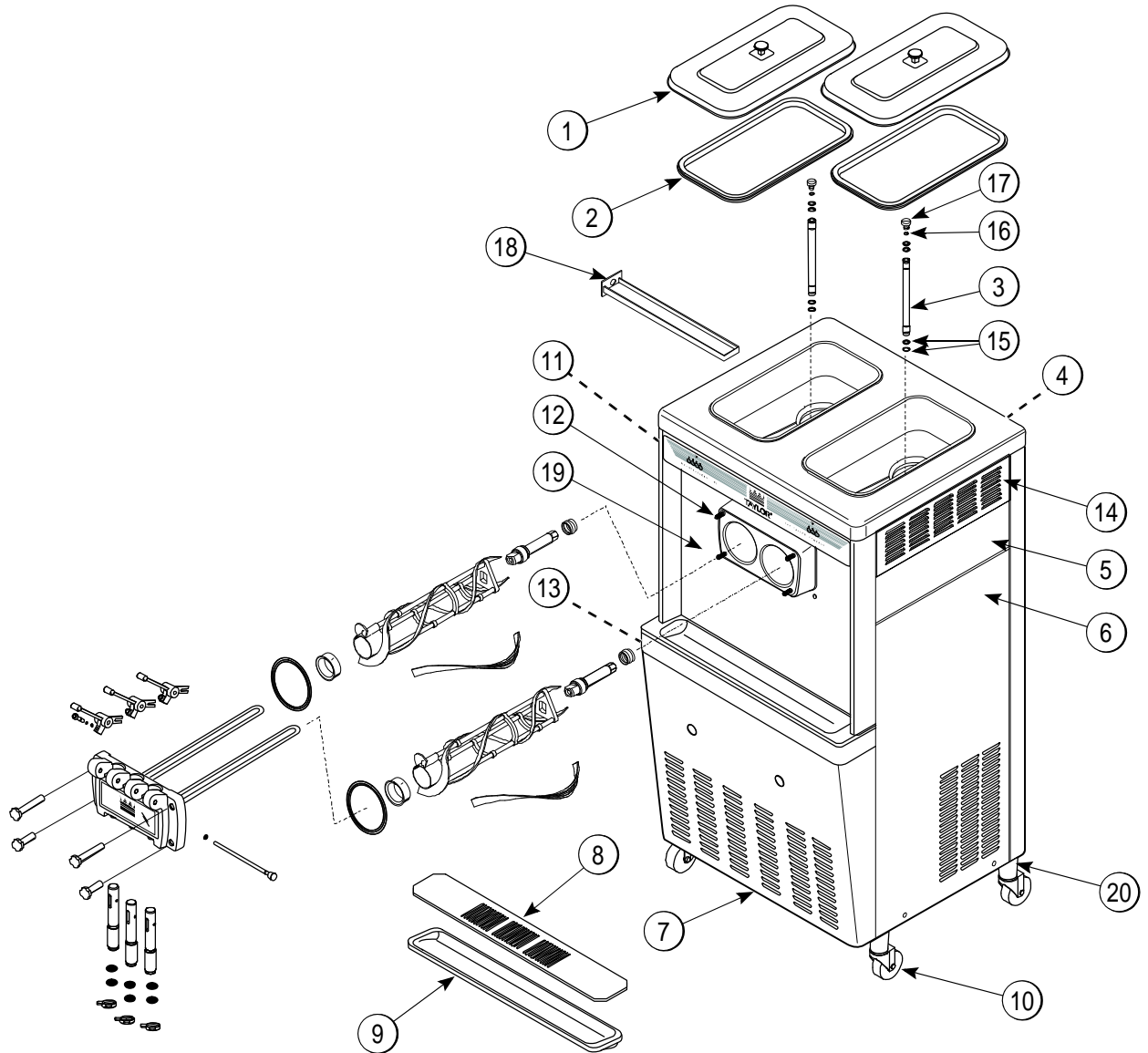

Figure 4-3

Item	Description	Part No.
1	Cover A.-Hopper	X38458-SER
2	Gasket-Hopper Cover	038474
3	Tube A.-Feed	X29429-2
4	Panel-Rear	053782
5	Panel-Upper Side Right	028823
6	Panel A.-Side Lower Right	X46448-SER
7	Panel-Service	046584
8	Shield-Splash	022766
9	Tray-Drip	014533
10	Caster-Swivel	018794

Item	Description	Part No.
11	Panel-Upper Side Left	028822
12	Stud-Nose Cone	022822
13	Panel A.-Side Lower Left	X46447-SER
14	Louver-Side-Top	051191
15	O-ring-.643 OD x .077 W	018572
16	O-ring-3/8 OD x .070 W	016137
17	Orifice	022465-100
18	Pan-Drip 17-1/4" Long	027504
19	Panel A.-Front	X32956
20	Adaptor A.-Caster	X18915

Model 774

4

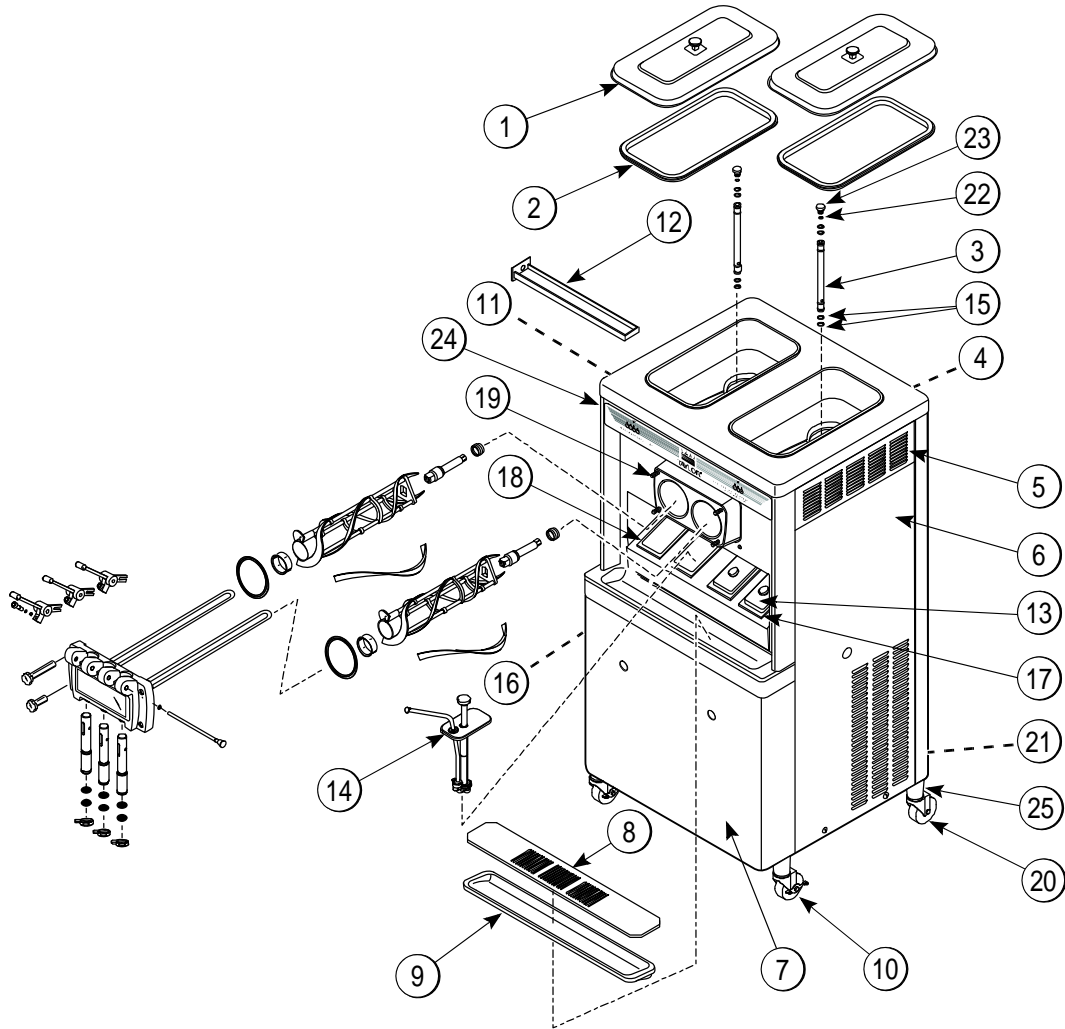

Figure 4-4

Item	Description	Part No.
1	Cover A.-Hopper	X38458-SER
2	Gasket-Hopper Cover 20 Qt.	038474
3	Tube A.-Feed	X29429-2
4	Panel-Upper Rear Inactive	X42574
5	Louver-Side-Top	051191
6	Panel A.-Side Lower-Right	X46448-SER
7	Panel-Service	047077
8	Shield-Splash	022766
9	Tray-Drip	014533
10	Caster-4" Swivel 5/8 Stem/Brake	034081
11	Panel-Upper Side Left	028822
12	Pan-Drip 17-1/4" Long	027504
13	Lid with Ladle 1 oz.	036575

Item	Description	Part No.
14	Pump A.-Syrup-Tan	053794-TAN
15	O-ring-.643 OD x .077 W	018572
16	Panel A.-Side Lower-Left	X46447-SER
17	Jar-Syrup-Plastic Shallow	036573
18	Jar-Syrup-Stainless-Shallow	036574
19	Stud-Nose Cone	022822
20	Caster-4" Swivel 5/8" Stem	018794
21	Panel-Lower Rear Inactive	053837
22	O-ring-3/8 OD x .070 W	016137
23	Orifice	022465-100
24	Panel A.-Front-Syrup Inactive	X42539
25	Adaptor A.-Caster	X18915

Model 774 Topping Pump (053794-)

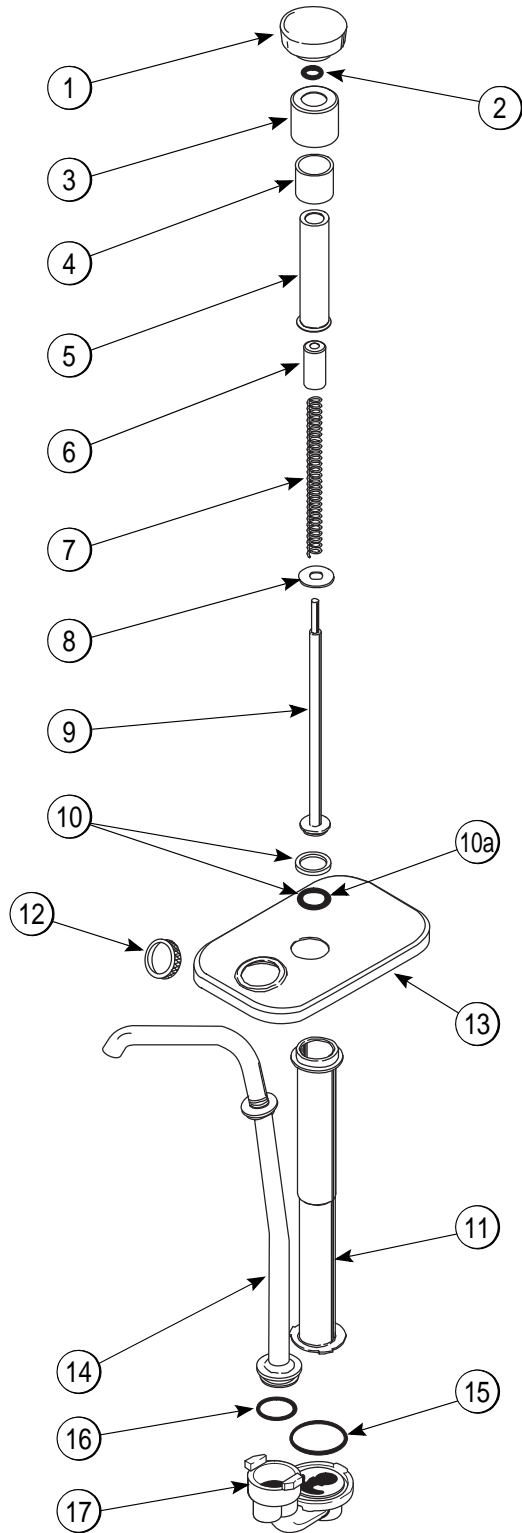

Figure 4-5

Item	Description	Part No.
1	Knob-Plunger-Tan	032762-TAN
1	Knob-Plunger-Brown	032762-BRN
1	Knob-Plunger-Red	032762-RED
2	O-ring-9/16 OD x .103 W	016369
3	Nut-Plunger	036577
4	Collar-Gaging 1/2 oz.	035514
5	Tube-Plunger	032757
6	Insert-Plunger	032758
7	Spring-Plunger	032761
8	Washer-Nylon	032760
9	Plunger	036578
10	Seal Assembly	X33057
10a	O-ring-13/16 OD x .103 W	019330
11	Body-Syrup Pump	047934
12	Nut-Spout	036821
13	Lid-Pump	036822
14	Tube-Discharge	050912
15	O-ring-1-5/16 OD x .103 W	048149
16	O-ring-1 OD x .103 W	048148
17	Kit-Valve-Captured Ball Shallow	048166-001
Includes:		
1 - Body A.-Pump Valve		
1 - O-ring-1-5/16 OD x .103W (048149)		
1 - Brush-Cleaning (054068)		
1 - Instruction Sheet-Installation/Cleaning		

Model 791

4

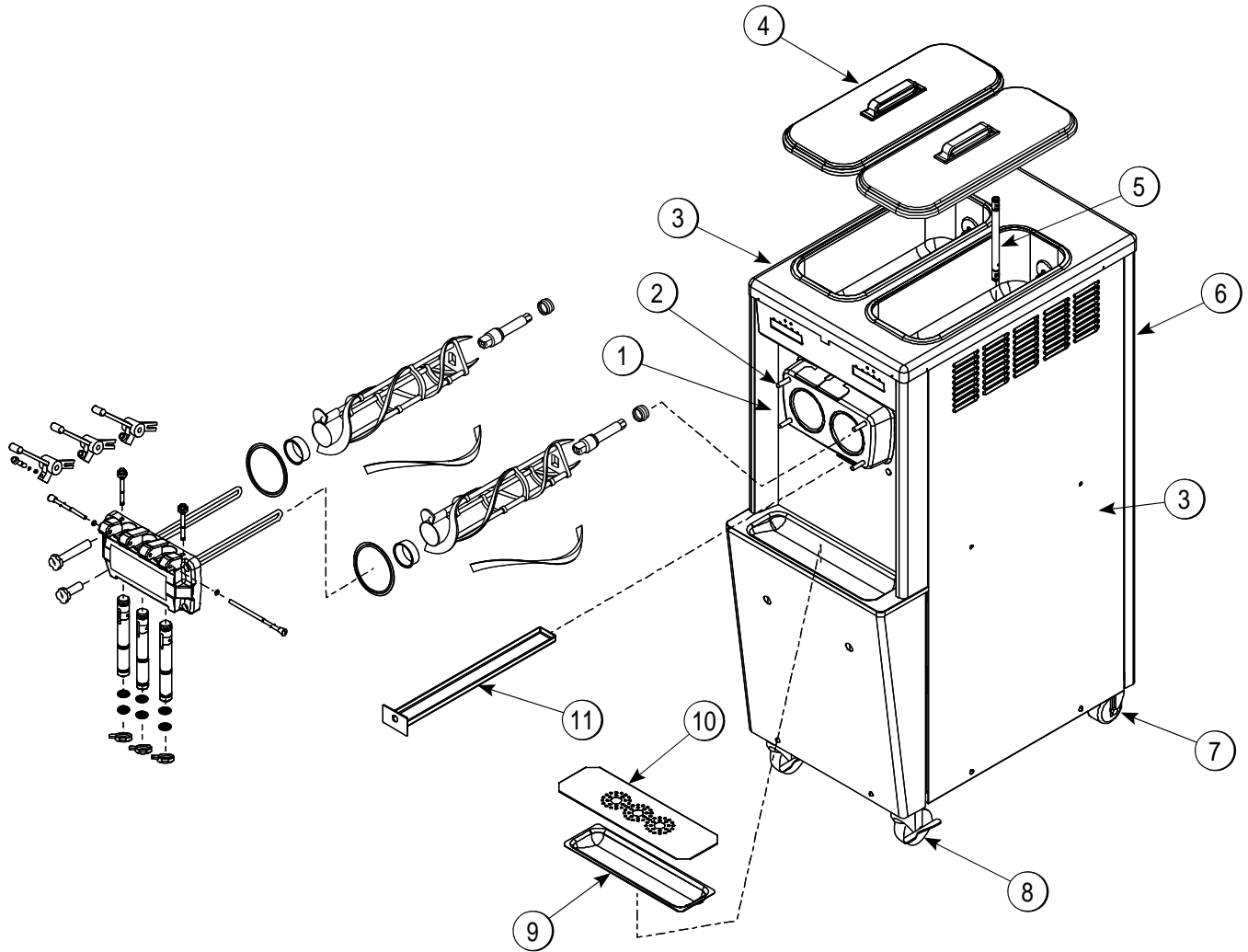
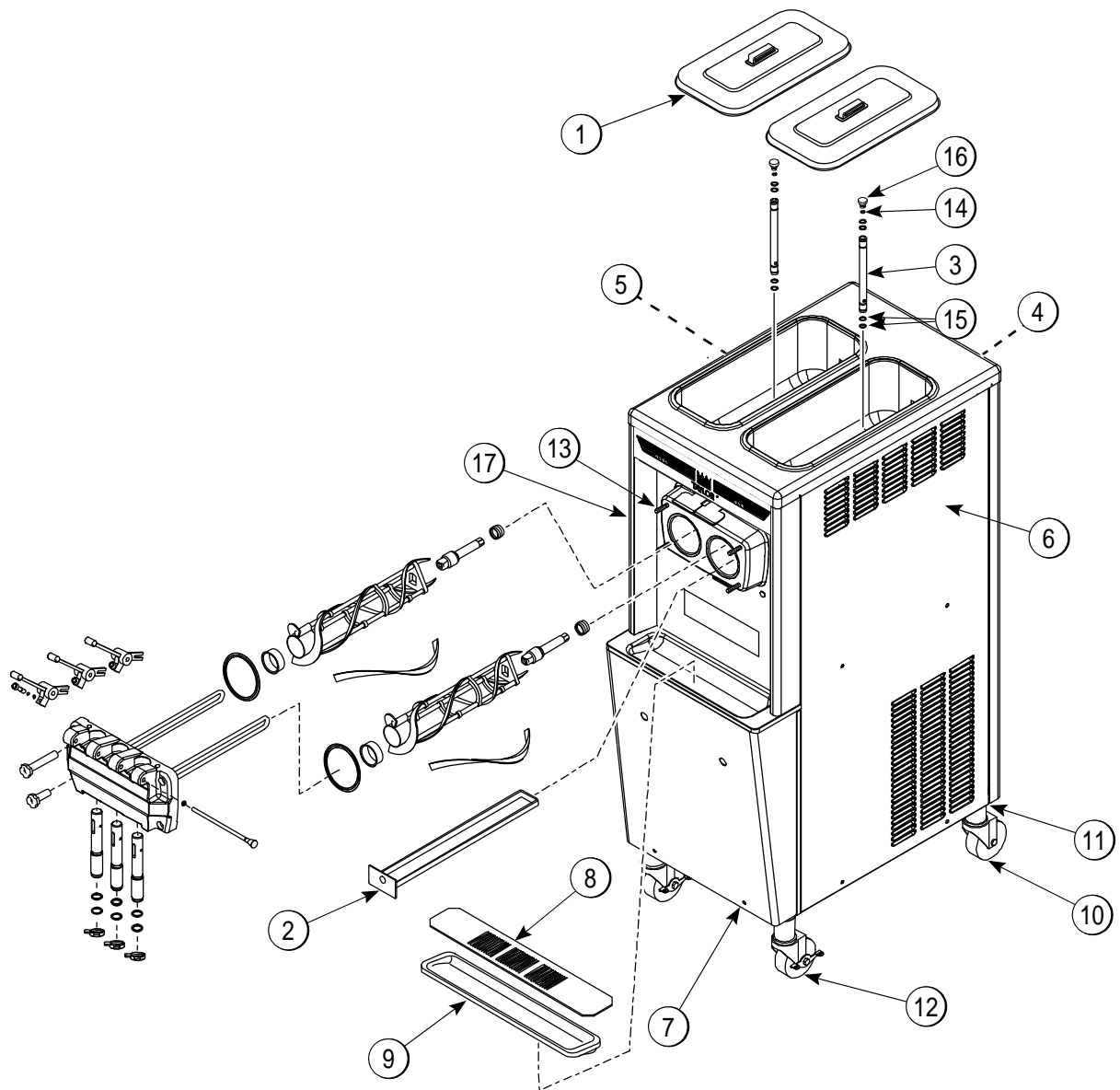

Figure 4-6

Item	Description	Part No.
1	Panel A.-Front	X41820-SP3
2	Stud-Nose Cone	068410
3	Panel-Side	069038
4	Kit A.-Cover-Hopper	X68150
5	Tube A.-Feed-SS-5/32	X29429-2
6	Panel-Rear	041855

Item	Description	Part No.
7	Caster-4" SWV 5/8 Stem	018794
8	Caster-4" SWV 5/8 Stem W/Brake	034081
9	Tray-Drip 16-7/8L x 5-1/8	020157
10	Shield-Splash	022765
11	Pan-Drip 19-1/2 Long	035034

Model 794



4

Figure 4-7

Item	Description	Part No.
1	Cover-Hopper-14 Qt	041682-GRY
2	Pan-Drip 19 1/2 Long	035034
3	Tube A.-Feed	X29429-2
4	Panel-Rear	041855
5	Panel-Side *Left	068691
6	Panel-Side *Right	068692
7	Panel-Service	064000
8	Shield-Splash	022765
9	Tray-Drip	021057

Item	Description	Part No.
10	Caster-4" SWV 5/8 Stem	018794
11	Adaptor A.-Caster	X18915
12	Caster-4" SWV 5/8 Stem w/Brake	034081
13	Stud-Nose Cone	022822
14	O-ring-3/8 OD x .070W	016137
15	O-ring-.643 OD x .077W	018572
16	Orifice	022465-100
17	Panel A.-Front	X41820-SP3

Models 750 and 751 Single-Spout Door and Beater Assembly

4

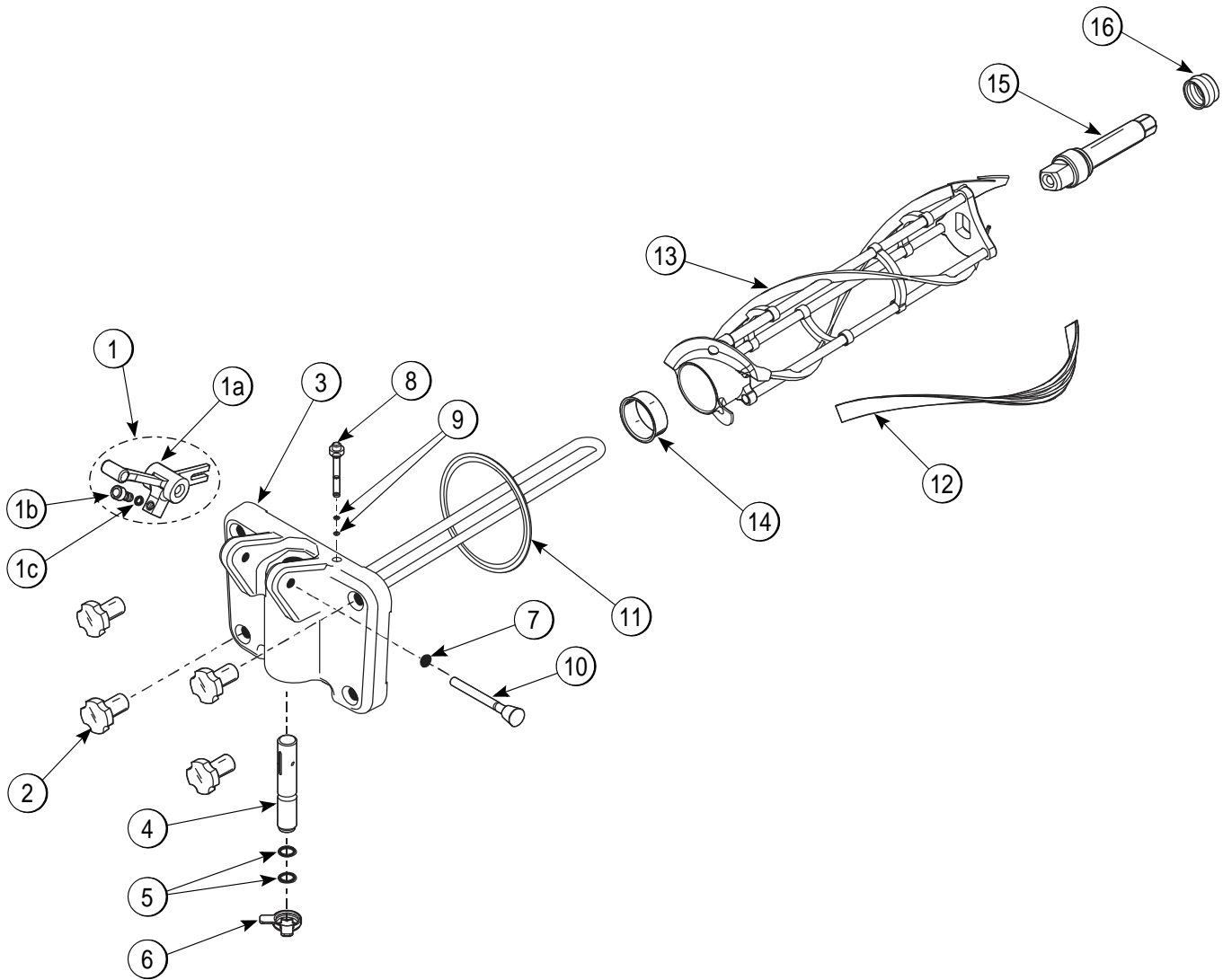
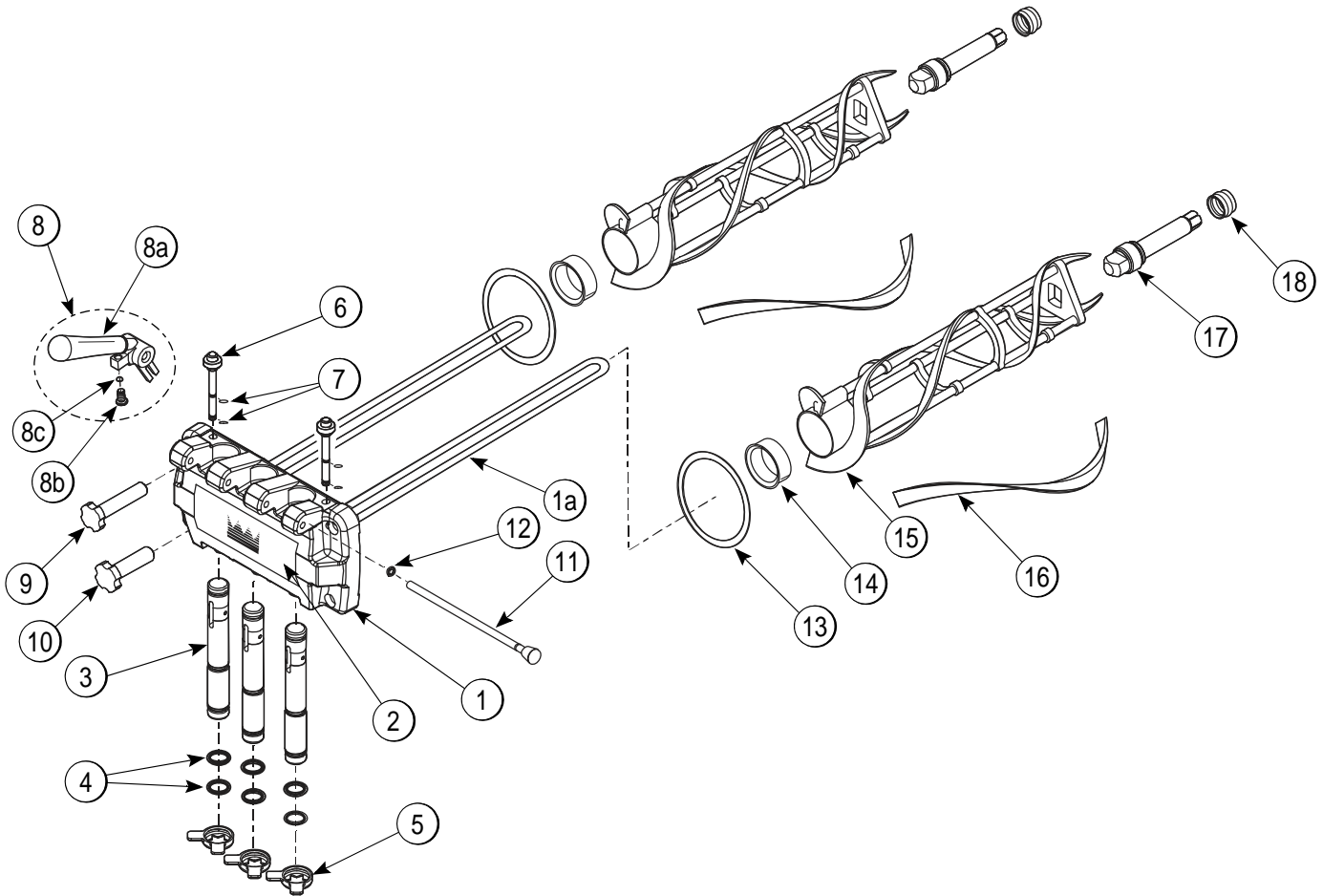

Figure 4-8

Item	Description	Part No.
1	Handle A.-Draw Nonadj	X69016
1a	Draw Handle	028804
1b	Screw-Adjustment	069014
1c	O-ring 1/4OD x .070W	015872
2	Nut-Stud Flat Long	021508
3	Door A.- 1-Spout	X51531-10
4	Valve A.- Draw	X18303
5	O-ring 7/8OD x .070W	014402
6	Cap-Design	014218
7	O-ring 5/16OD x .070W	016272

Item	Description	Part No.
8	Plug-Prime	028805
9	O-ring-Prime Plug	016137
10	Pin A.- Pivot	X22820
11	Gasket-Door HT 4"	048926
12	Blade- Scraper	035174
13	Beater A.- Helicore	X31761
14	Bearing-Front	050216
15	Shaft-Beater	032564
16	Seal-Drive Shaft	032560

Models 754, 774 and 794 Three-Spout Door and Beater Assembly



4

Figure 4-9

Item	Description	Part No.
1	Door A.-3 Spout	X51532-12
1a	Baffle A.-Long 4 IN	X50882
2	Decal-Door-3 Spout	021521
3	Valve A.-Draw	X69539
4	O-ring-7/8 OD x .103W-SIL	083693
5	Cap-Design 1.010" ID-6 Point	014218
6	Plug-Prime	028805
7	O-ring-3/8 OD x .070W	016137
8	Handle A.-Draw *White	X81010-SP
8a	Handle-Draw-White	056248-1
8b	Screw-ADJ.-5/16-24	056332

Item	Description	Part No.
8c	O-ring-1/4 OD x .070W 50	015872
9	Nut-Stud *Long	034382
10	Nut-Stud *Short	034383
11	Rod A.-Pivot	X20683
12	O-ring-5/16 OD x .070W	016272
13	Gasket-Door HT 4"-Double	048926
14	Bearing-Front	050216
15	Beater A.-3.4QT-Helicore	X31761
16	Blade-Scraper-Plastic	035174
17	Shaft-Beater	032564
18	Seal-Drive Shaft	032560

Model 791 Three-Spout Door and Beater Assembly

4

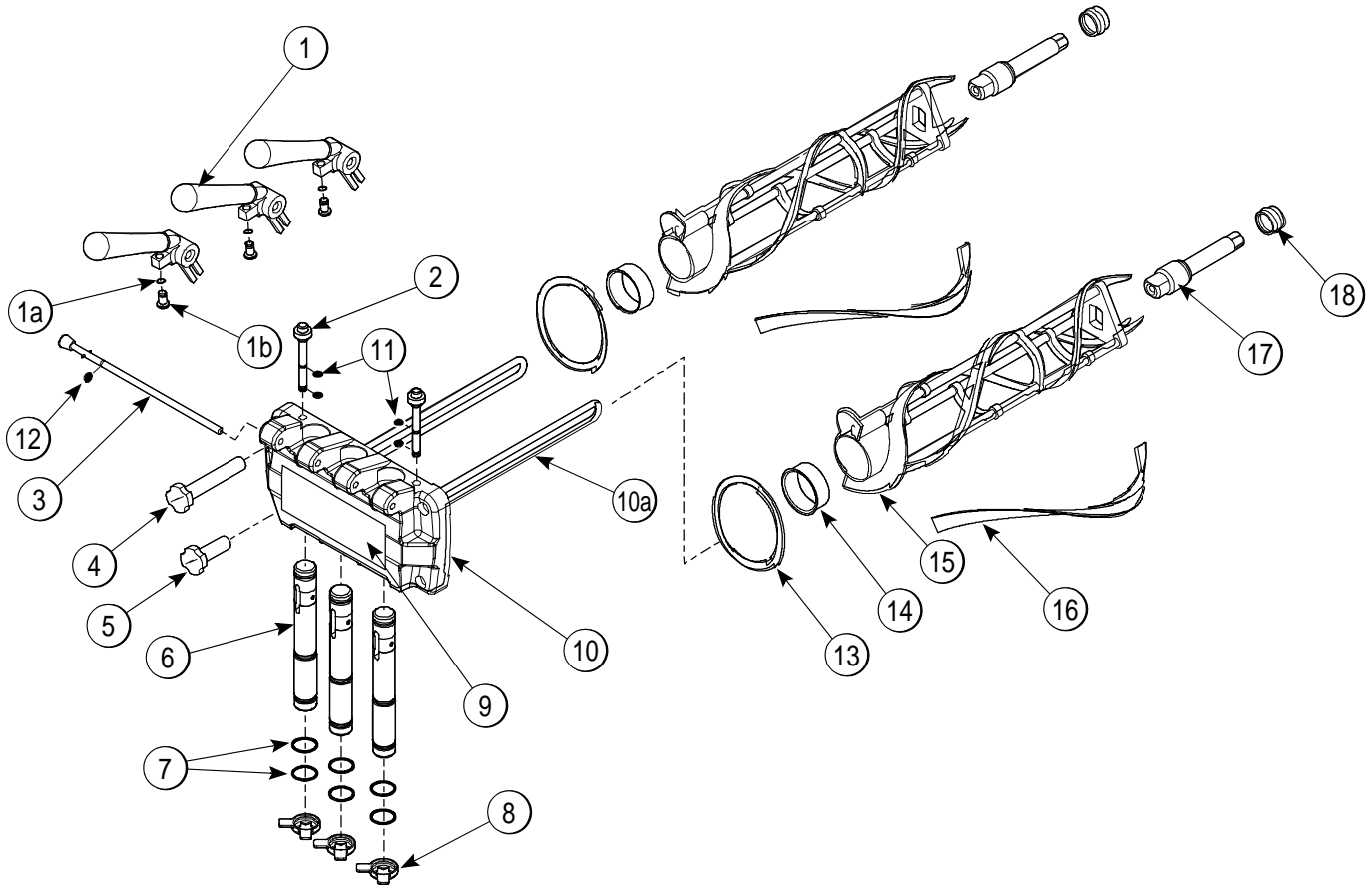
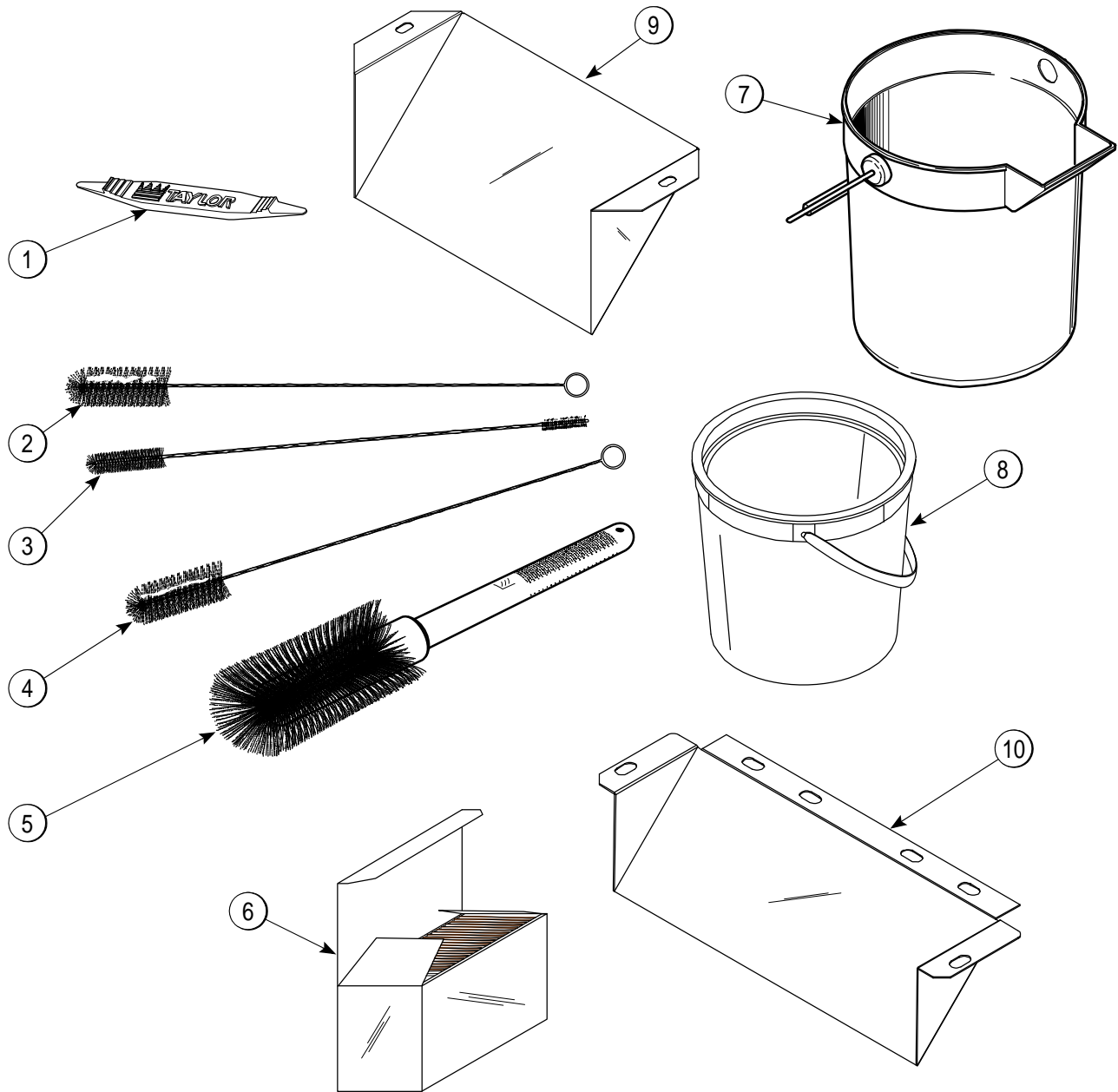

Figure 4-10

Item	Description	Part No.
1	Handle A.-Draw *White	X81010-SP
1a	O-ring 1/4OD x .070W	015872
1b	Screw-Adjustment	056332
2	Plug-Prime	028805
3	Rod A.-Pivot	X20683
4	Nut-Stud *Long	034382
5	Nut-Stud *Short	034383
6	Valve A.-Draw	X69539
7	O-ring-7/8 OD x .103W-SIL	083693
8	Cap-Design	014218
9	Decal-Door-3 Spout	021521

Item	Description	Part No.
10	Door A.-3 Spout	X51532-12
10a	Baffle A.-Long 4 IN	X50882
11	O-ring-Prime Plug	016137
12	O-ring 5/16OD x .070W	016272
13	Gasket-Door HT 4"	048926
14	Bearing-Front	050216
15	Beater A.- Helicore	X31761
16	Blade- Scraper	035174
17	Shaft-Beater	032564
18	Seal-Drive Shaft	032560

Accessories



4

Figure 4-11

Item	Description	Part No.
1	Tool-O-ring Removal	048260-WHT
2	Brush-Rear Bearing 1" D x 2"L	013071
3	Brush-Double Ended	013072
4	Brush-Draw Valve 1" x 2" x 17"	013073
5	Brush-Mix Pump Body 3" x 7" White	023316
*6	Sanitizer-Stera-Sheen® Green	See note
7	Pail-10 qt. (751, 754, 774, 791, 794)	013163

Item	Description	Part No.
8	Pail-6 Qt. (750)	023348
9	Deflector-Blower Exhaust (794)	047912
10	Deflector-Blower Exhaust (751, 754, 774)	046586

* A sample container of sanitizer is sent with the unit. For reorders, order Stera-Sheen® part no. 055492 (100 2 oz. packs) or Kay-5® part no. 041082 (200 packs).

750/751

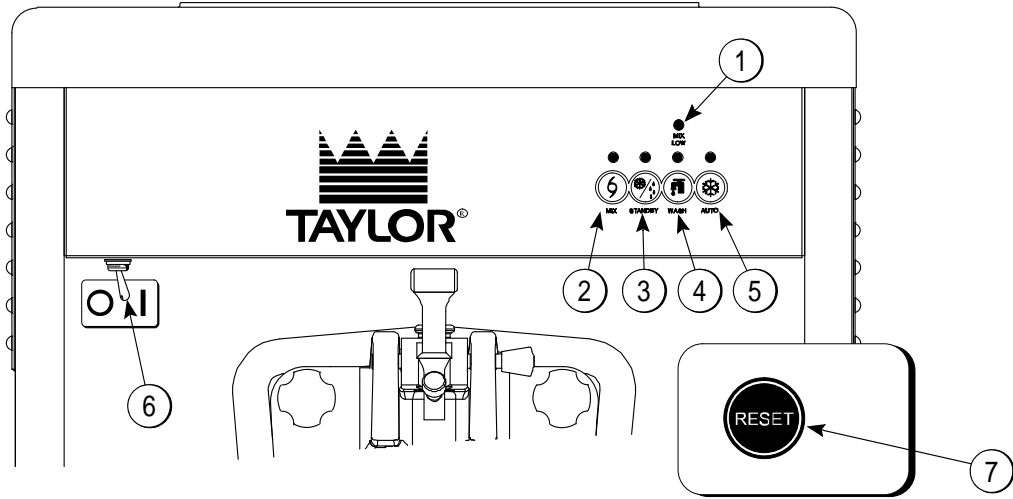

Figure 5-1

754/774/791/794

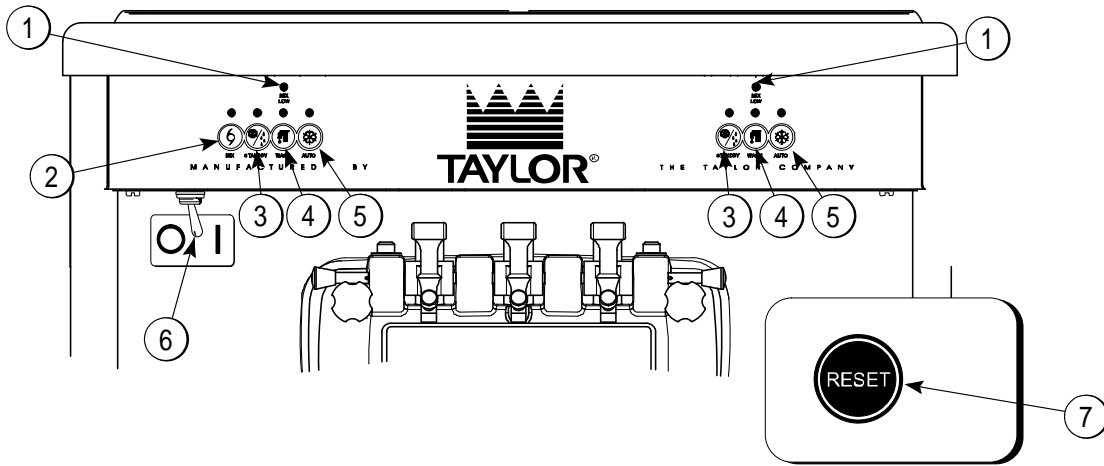







Figure 5-2

Item	Description
1	MIX LOW Indicator Light
2	MIX Refrigeration Button
3	STANDBY Button
4	WASH Button
5	AUTO Button
6	Power On/Off (Toggle Switch)
7	RESET Button

Note: Legend for figures 5-1 and 5-2.

Symbol Definitions

To better communicate in the international arena, the words on many of our operator switches and buttons have been replaced with symbols to indicate their functions. Your Taylor machine is designed with the following international symbols.

	=	ON		=	WASH
	=	OFF		=	AUTO
	=	MIX		=	STANDBY

Power Switch

When placed in the ON position, the power switch allows Softech™ control panel operation.

5 MIX LOW Indicator Light

Located on the front of the machine is a mix level indicating light. When the light is flashing, it indicates that the mix hopper has a low supply of mix and should be refilled as soon as possible. Always maintain at least 3 in. (7.6 cm) of mix in the hopper. If you neglect to add mix, a freeze-up may occur. This will cause eventual damage to the beater, blades, driveshaft, and freezer door.

MIX Refrigeration Button

When the MIX refrigeration button is pressed, the light comes on, indicating the mix hopper refrigeration system is operating. For Models 754, 774, 791, and 794, the Mix refrigeration is controlled by the left side of the freezer as viewed from the operator end. The Mix refrigeration function cannot be canceled unless the Auto or Standby modes are canceled first.

STANDBY Button

The separate hopper refrigeration (SHR) system and the cylinder temperature retention (CTR) system are standard features on these machines. The SHR incorporates the use of a separate small refrigeration system to maintain the mix in the hopper below 40°F (4.4°C) to ensure bacteria control. The CTR system works with the SHR system to maintain a good quality product. During long **no sale** periods, it is necessary to warm the product in the freezing cylinder to approximately 35°F to 40°F (1.7°C to 4.4°C) to prevent overheating and product breakdown.

To activate the SHR and CTR, press the STANDBY button. Remove the air orifice and place the air tube (**end without the hole**) into the mix inlet hole.

Important! Make sure the level of mix in the hopper is below the mix delivery hole in the feed tube. Failure to follow this instruction may result in lower product quality when normal operation is resumed.

When the Standby button is pressed, the light comes on, indicating the CTR system has been activated. In the Standby mode, the Wash and Auto functions are automatically canceled. The Mix refrigeration function is automatically locked in to maintain the mix in the hopper.

To resume normal operation, press the AUTO button. When the machine cycles off, the product in the freezing cylinder will be at serving viscosity. At this time, place the air tube (**end with the hole**) into the mix inlet hole and install the air orifice.

WASH Button

When the WASH button is pressed, the light comes on. This indicates beater motor operation. The Standby or Auto modes must be canceled first to activate the Wash mode.

AUTO Button

When the AUTO button is pressed, the light comes on. This indicates that the main refrigeration system has been activated. In the Auto mode, the Wash or Standby functions are automatically canceled. The Mix refrigeration function is automatically locked in to maintain the mix in the mix hopper.

Note: An indicating light and an audible tone will sound whenever a mode of operation has been pressed. To cancel any function, press the button again. The light and mode of operation will shut off.

RESET Button

On counter models, the RESET button is located on the side of the machine. On console models, the RESET button is located in the service panel. The reset protects the beater motor from an overload condition. If an overload occurs, the reset mechanism will trip. To properly reset the freezer, press the AUTO button to cancel the cycle. Turn the power switch to the OFF position. Press the RESET button firmly.



DANGER! DO NOT use metal objects to press the RESET button. Failure to comply may result in severe personal injury or death.

Turn the power switch to the ON position. Press the WASH button and observe the freezer's performance. Open the side access panel. Make sure the beater motor is turning the driveshaft in a clockwise direction (from the operator end) without binding.

If the beater motor is turning properly, press the WASH button to cancel the cycle. Press the AUTO button to resume normal operation. If the freezer shuts down again, contact a service technician. (For Models 754, 774, 791, and 794, press the AUTO button on both sides of the machine to resume normal operation.)

Air Tube

The air tube serves two purposes. One end of the tube has a hole, and the other end does not.

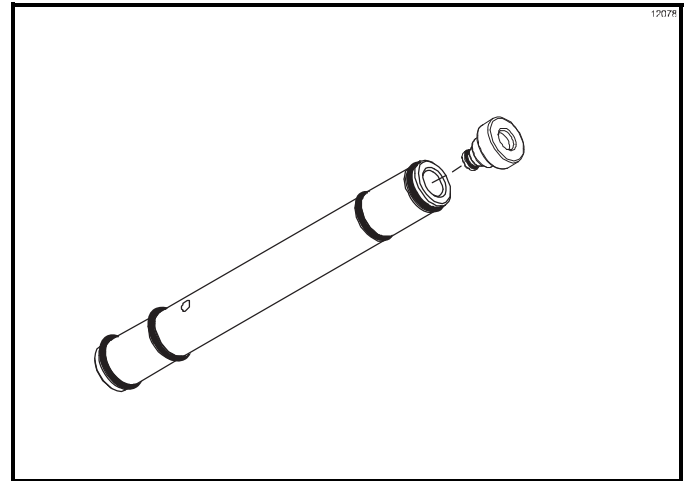

Figure 5-3

1. After priming the machine, lubricate the O-rings on the air tube (**the end with the hole**) and place it into the mix inlet hole. Every time the draw handle is raised, new mix and air from the hopper will flow down into the freezing cylinder. This will keep the freezing cylinder properly loaded and will maintain overrun.
2. During long **no sale** periods, remove the air orifice. Lubricate the O-rings on the air tube (**the end without the hole**), and place it into the mix inlet hole. This will prevent any mix from entering the freezing cylinder.

Important! Make sure the level of mix in the hopper is below the mix delivery hole in the feed tube. Failure to follow this instruction may result in lower product quality when normal operation is resumed.

The air orifice is used to meter a certain amount of air into the freezing cylinder. The air orifice maintains overrun and allows enough mix to enter the freezing cylinder after a draw.

Adjustable Draw Handle

These machines feature an adjustable draw handle to provide the best portion control. The draw handle should be adjusted to provide a flow rate of 5 to 7-1/2 oz. (148 to 222 ml) of product per 10 seconds. To **increase** the flow rate, turn the screw **counterclockwise**. Turn the screw **clockwise** to **decrease** the flow rate. During Sanitizing and Rinsing, the flow rate can be increased by removing the pivot pin and placing the restrictive bar on the **top**. When drawing product, always place the restrictive bar on the bottom.

Important! When dispensing product, pull only one draw handle at a time.

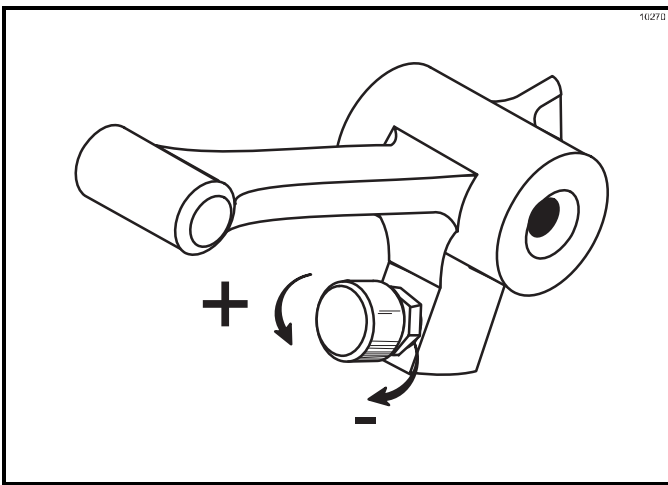

Figure 5-4

Note: Once the draw rate is set, tighten the locknut with a wrench.

Model 751 has been selected to illustrate the step-by-step operating procedures for all models contained in this manual. These models, for all practical purposes of operation, are the same.

Each machine stores mix in a hopper. The mix then flows by gravity through an air tube down into the freezing cylinder. They all have 3.4 qt. (3.2 L) capacity freezing cylinders. Models 750, 751, 754, and 774 have 20 qt. (18.9 L) mix hoppers. Models 791 and 794 have 14 qt. (13.2 L) mix hoppers.

Duplicate the following procedures where they apply for the second freezing cylinder on Models 754, 774, 791, and 794.

We begin our instructions at the point when we enter the store in the morning and find the parts disassembled and laid out to air-dry from the previous night's cleaning.

These opening procedures will show you how to assemble these parts into the freezer, sanitize them, and prime the freezer with fresh mix in preparation to serve your first portion.

If you are disassembling the machine for the first time or need information to get to this starting point in our instructions, turn to page 6-9, "Disassembly," and start there.

Prior to Setup (Model 774)

1. Remove the two stainless-steel syrup jars with topping pumps from the syrup rail. Check the water level in the heated syrup topping well. Make sure the water is filled to the indicating mark on the bottom of the well. The heated rail should have 32 oz. (946.2 ml) of water.
2. Place the heater switch in the ON position.

Note: This heating process will take approximately 2.5 hours to reach temperature. The water level in the topping wells must be checked at least once daily.
3. Prepare a pail of an approved 100 ppm sanitizing solution (examples: 2.5 gal. [9.5 L] of Kay-5[®] or 2 gal. [7.6 L] of Stera-Sheen[®]).

Use warm water and follow the manufacturer's specifications. Sanitize the topping pumps by placing the entire pump assembly in the pail of sanitizing solution. Pump the solution through the assembly to thoroughly sanitize the pump.

4. Remove the two topping pumps. Fill each stainless steel syrup jar with topping. Replace the topping pumps in the syrup jars.

Assembly

Note: When lubricating parts, use an approved food-grade lubricant (example: Taylor Lube).



WARNING! Make sure the power switch is in the OFF position! Failure to follow this instruction may result in severe personal injury to fingers or hands from hazardous moving parts.

1. Lubricate the groove and shaft portion that comes in contact with the bearing on the beater driveshaft. Slide the seal over the shaft and groove until it snaps into place. **Do not** lubricate the hex end of the driveshaft. Fill the inside portion of the seal with 1/4 in. (6.35 mm) more lubricant and lubricate the flat side of the seal that fits onto the rear shell bearing.

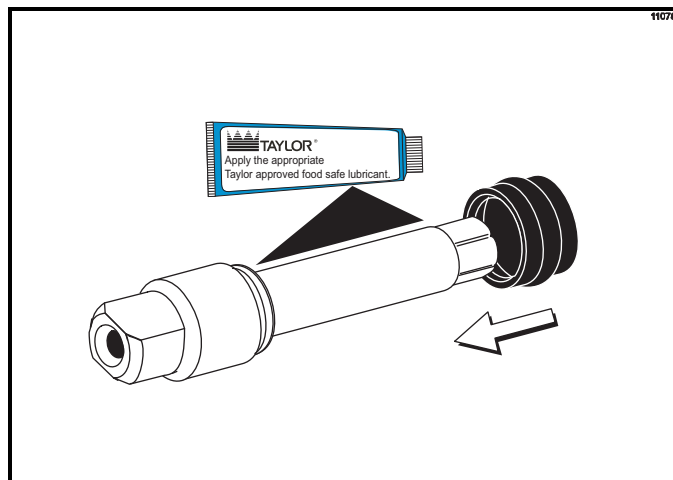

Figure 6-1

OPERATING PROCEDURES

2. Insert the driveshaft into the freezing cylinder, hex end first, and into the rear shell bearing until the seal fits securely over the rear shell bearing. Engage the hex end firmly into the drive coupling. Make sure the driveshaft fits into the drive coupling without binding.

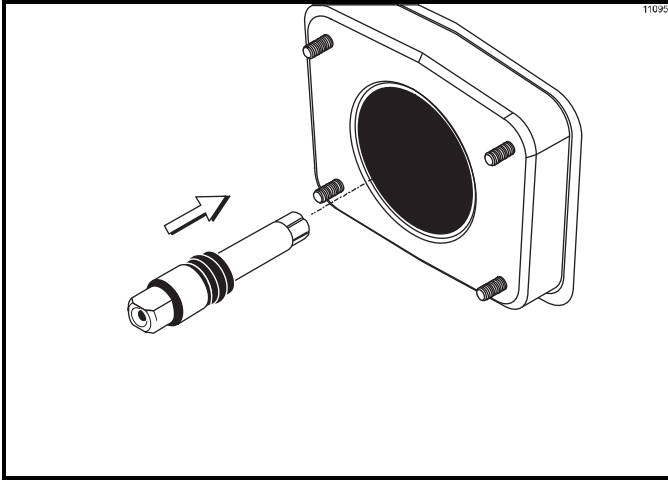

Figure 6-2

3. Take one of the scraper blades and slip it under the hook at the front of the beater. Wrap the blade around the beater, following the helix and pushing the blade down onto the helix as you wrap. At the back end of the beater, slip the blade under the hook. **Repeat this step** for the second scraper blade.

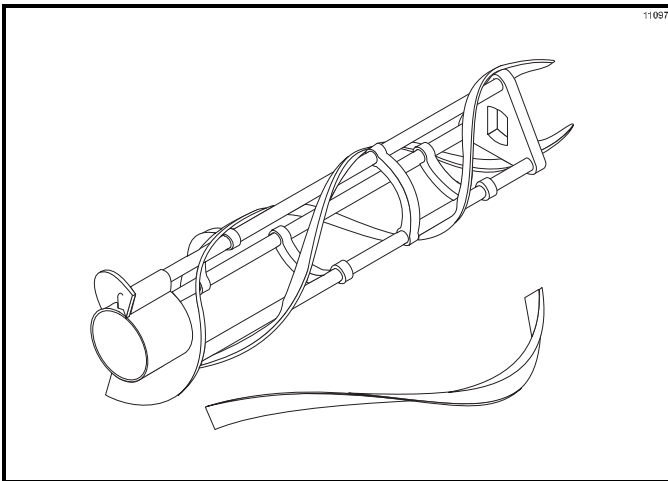

Figure 6-3

4. Holding the beater securely, slide the beater one third of the way into the freezing cylinder. Looking into the freezing cylinder, align the hole at the rear of the beater with the flats on the end of the driveshaft.

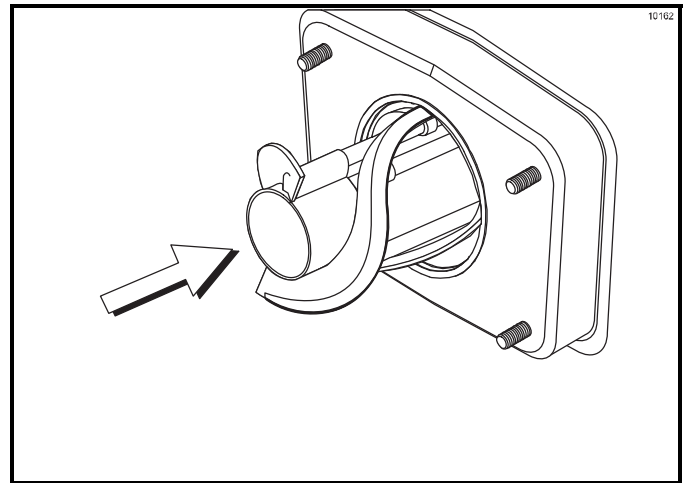

Figure 6-4

5. Slide the beater the remainder of the way into the freezing cylinder and over the end of the driveshaft. The beater should fit snugly, but not so tightly that the beater cannot be turned slightly to engage the driveshaft. If the beater slides in too easily with little or no resistance, there will not be enough force against the beater to hold the blades in place. If this is the case, contact your Taylor service technician.
6. **Repeat step 1 through step** for the other side of the freezer on Models 754, 774, 791, and 794.
7. Place the large rubber gasket(s) into the groove(s) on the back side of the freezer door.

Slide the white plastic front bearing(s) over the baffle rod(s) onto the bearing hub(s), making sure that the flanged end of the bearing is resting against the freezer door.

Note: *Do not lubricate the gasket(s) or the front bearing(s).*

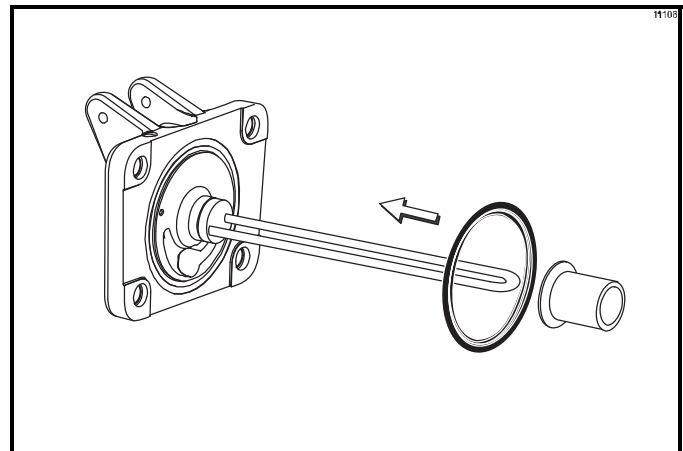

Figure 6-5

Note: There are two gaskets and two front bearings for the Models 754, 774, 791, and 794 door, one for each freezing cylinder.

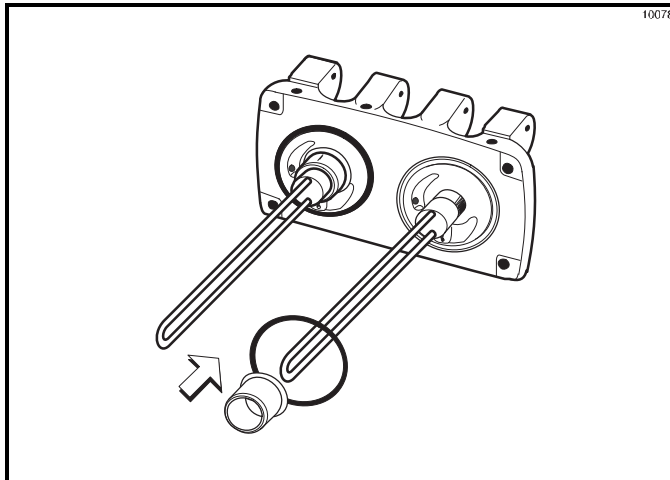

Figure 6-6

8. Slide the two O-rings into the grooves on the prime plug(s). Apply an even coat of Taylor Lube to the O-rings and shaft(s).

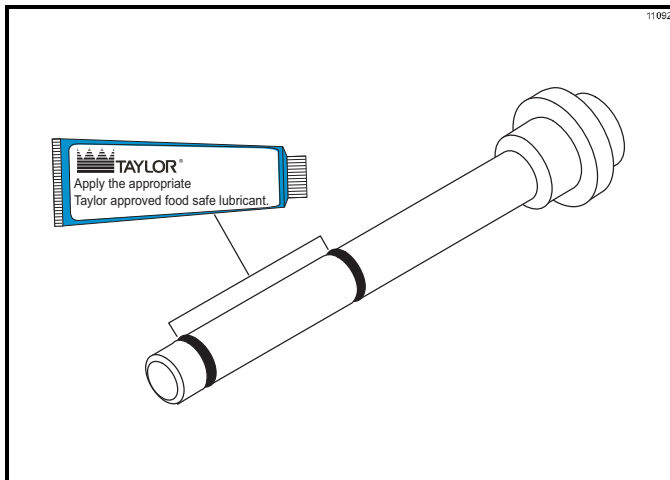

Figure 6-7

Note: There are two prime plugs for the Models 754, 774, 791, and 794 door, one for each freezing cylinder.

9. Insert the prime plug(s) into the hole(s) in the top of the freezer door, and push down.

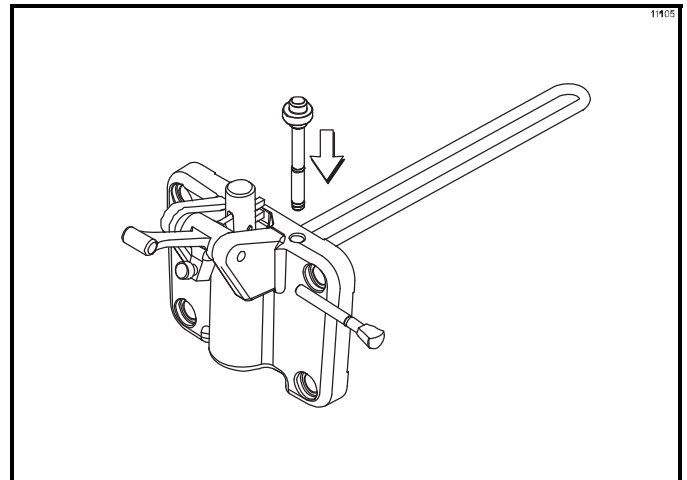

Figure 6-8

Note: On Models 754, 774, 791, and 794, the short handscrews go on the bottom, and the long handscrews go on the top.

10. Insert the baffle rod(s) through the opening in the beater(s) and seat the door flush with the freezing cylinder. With the door seated on the freezer studs, install the handscrews. Tighten equally in a crisscross pattern to ensure the door is snug.

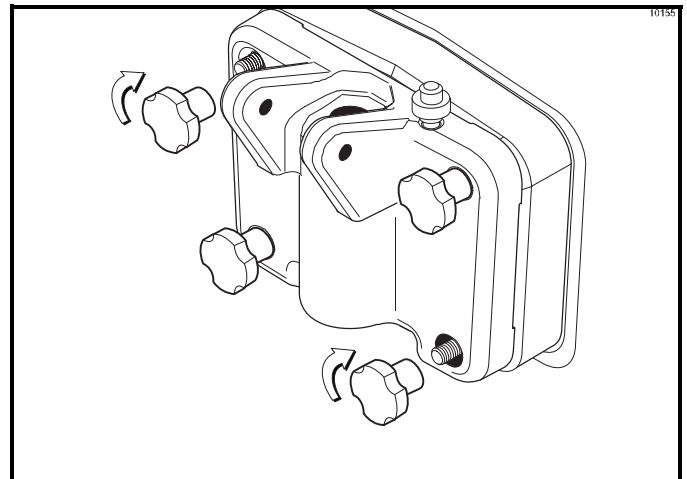

Figure 6-9

OPERATING PROCEDURES

11. Install the draw valve(s). Slide the two O-rings into the grooves on the draw valve(s) and lubricate.

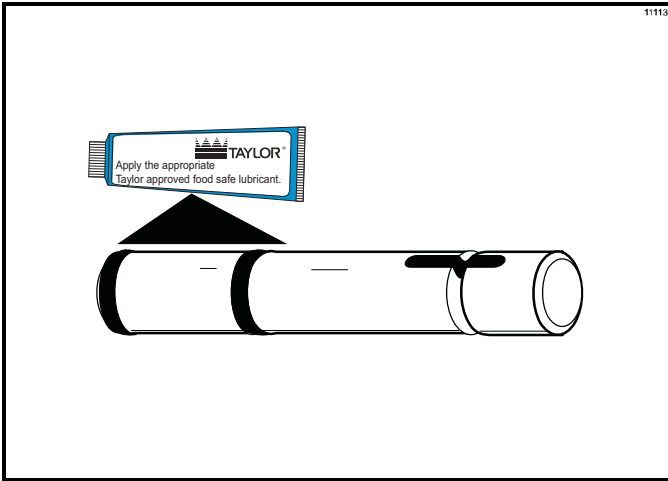

Figure 6-10

Note: Models 754, 774, 791, and 794 have three draw valves.

12. Lubricate the inside of the freezer door spout(s), top and bottom, and insert the draw valve(s) from the **bottom** until the slot in the draw valve(s) comes into view.

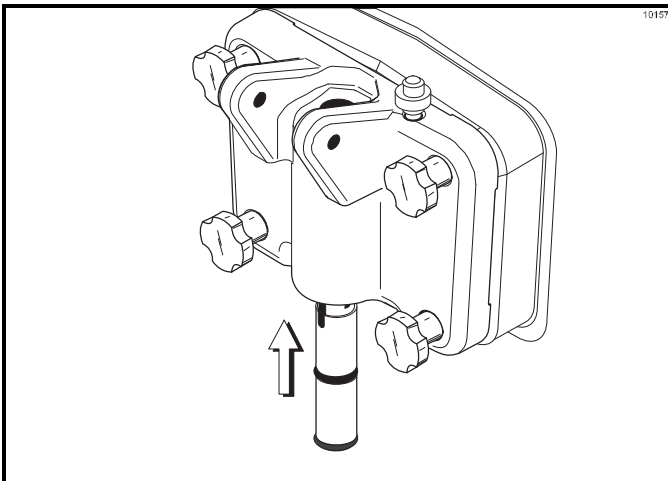

Figure 6-11

13. Install the adjustable draw handle(s). Slide the O-ring into the groove on the pivot pin, and lubricate.

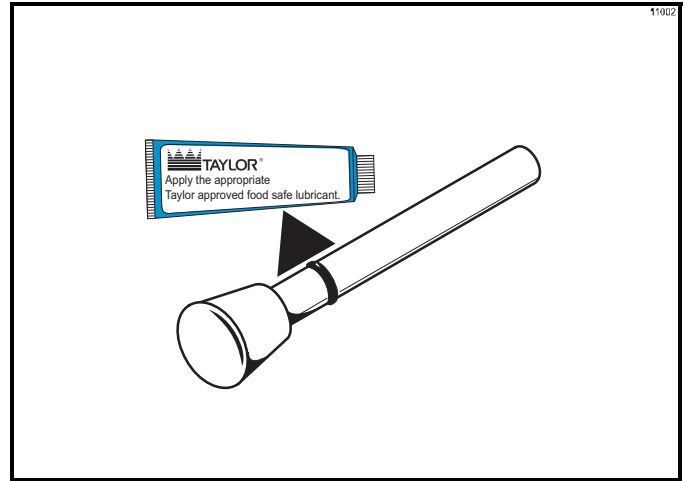

Figure 6-12

Note: Models 754, 774, 791, and 794 have three draw handles. Slide the fork of the draw handle in the slot of the draw valve, starting from the right. Slide the pivot pin through each draw handle as you insert them into the draw valves.

14. Slide the fork over the bar in the slot of the draw valve. Secure with the pivot pin.

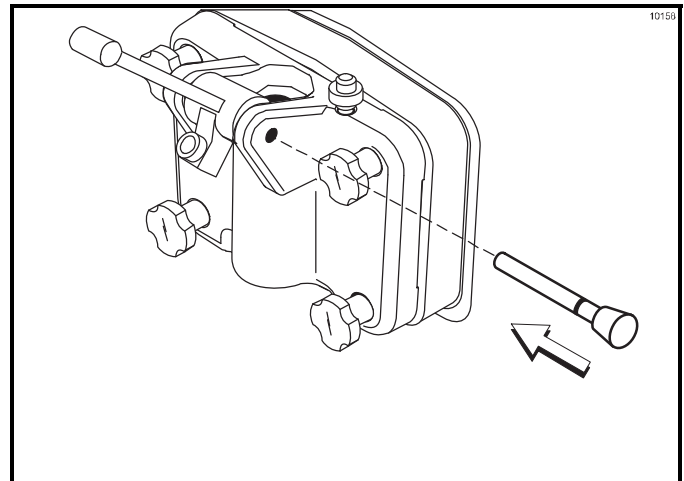

Figure 6-13

Note: These machines feature adjustable draw handles to provide the best portion control. The draw handles can be adjusted for different flow rates. See "Adjustable Draw Handle" on page 5-4 for more information on adjusting these handles.

15. Snap the design cap(s) over the end of the door spout(s).

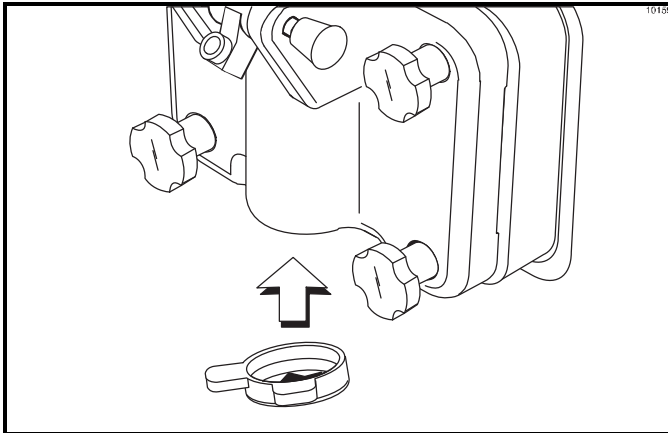

Figure 6-14

16. Install the front drip tray and the splash shield under the door spout(s).

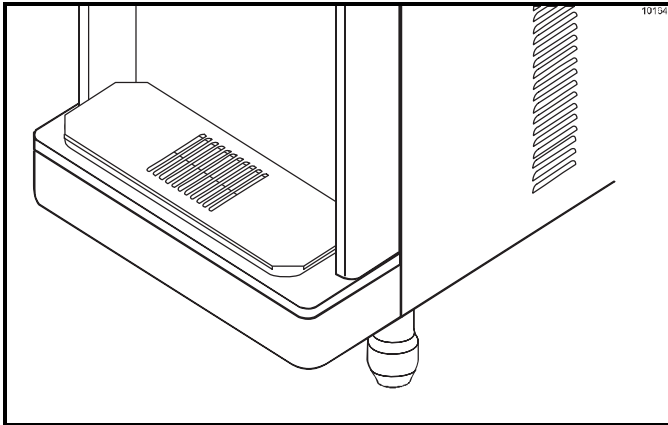

Figure 6-15

17. Slide the rear drip pan(s) into the hole in the side panel.

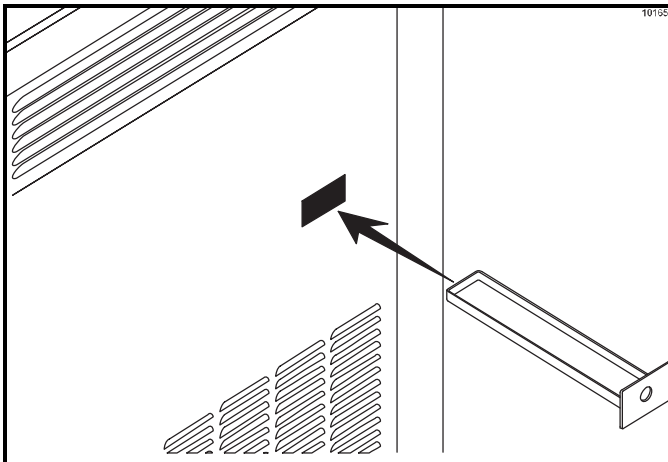

Figure 6-16

18. **Models 791 and 794:** Slide the rear drip pan into the hole in the front panel.

19. Slide two O-rings on one end of the air tube. Slide two O-rings on the other end of the air tube.

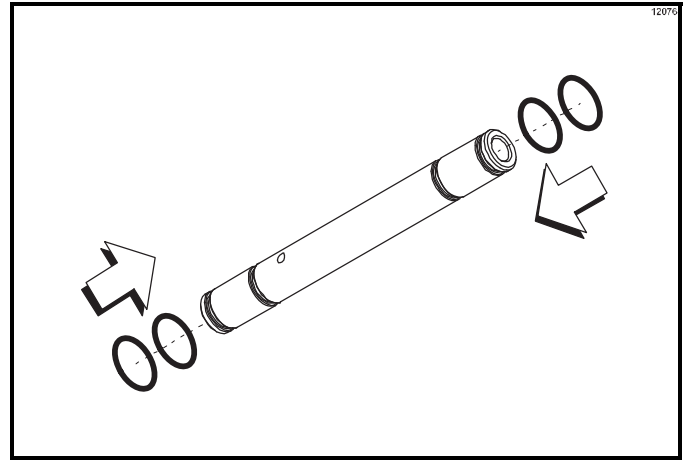

Figure 6-17

20. Slide the small O-ring into the groove of the air orifice. **Do not** lubricate the O-ring.

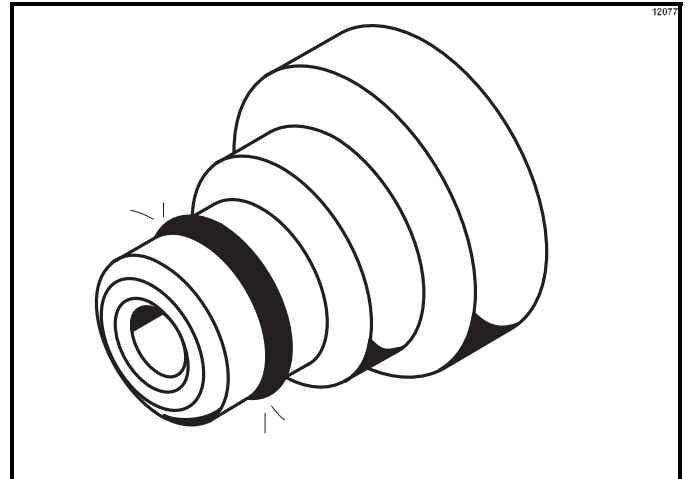

Figure 6-18

Note: Make sure the hole in the air orifice is clean and is not clogged. If the hole in the air orifice should become clogged, use soap and hot water to clear the hole.

Do not enlarge the hole in the air orifice.

OPERATING PROCEDURES

21. Install the air orifice into the hole in the top of the air tube (in the end without the small hole on the side).

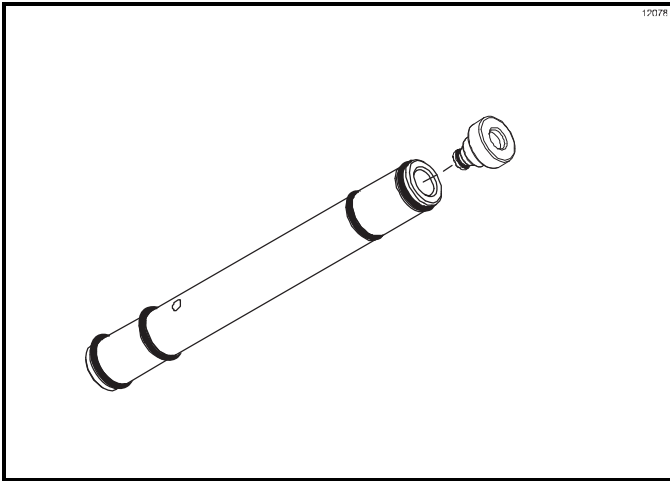

Figure 6-19

22. Lay the air tube (with the air orifice installed) and the hopper gasket in the bottom of the mix hopper for sanitizing.

Note: Models 754 and 774 have one hopper gasket for each mix hopper. Models 791 and 794 do not require a hopper gasket.

Repeat step 19 through step 22 for the other side of the freezer on Models 754, 774, 791, and 794.

6



CAUTION! DO NOT run the machine without product. Failure to follow this instruction can result in machine damage.

Sanitizing

Note: Use warm water and follow the manufacturer's specifications.

1. Prepare an approved 100 ppm sanitizing solution (examples: 2.5 gal. [9.5 L] of Kay-5[®] or 2 gal. [7.6 L] of Stera-Sheen[®]).
2. Pour the sanitizing solution into the hopper and allow it to flow into the freezing cylinder.

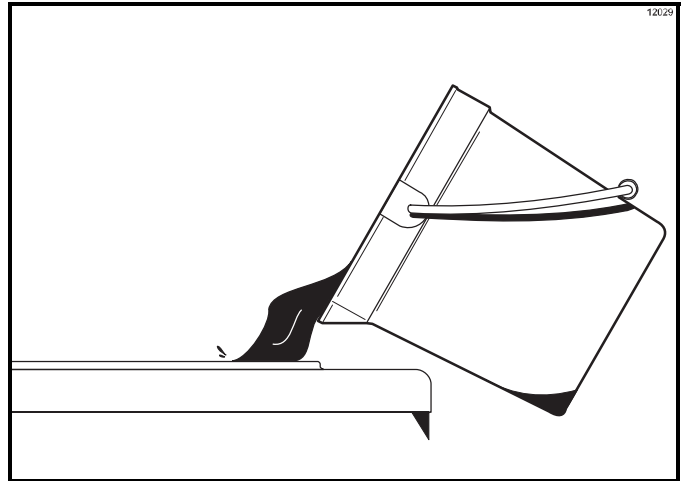

Figure 6-20

3. While the solution is flowing into the freezing cylinder, brush-clean the mix hopper. When cleaning the hopper, take particular care in brushing the mix-level sensing probe on the rear wall of the hopper, the mix inlet hole, the air tube, and the hopper gasket.

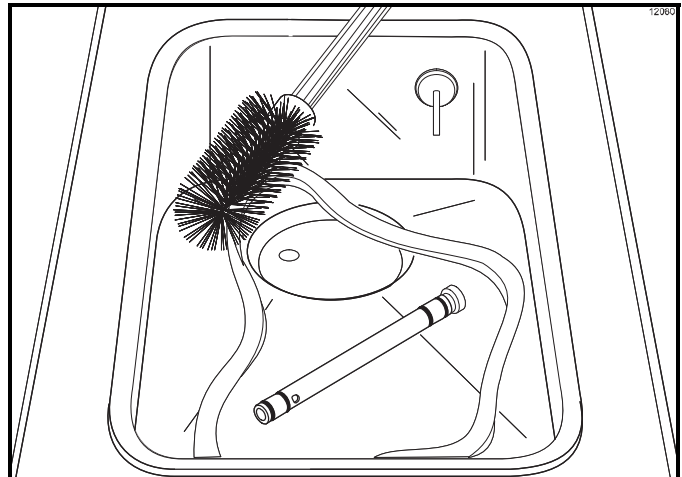

Figure 6-21

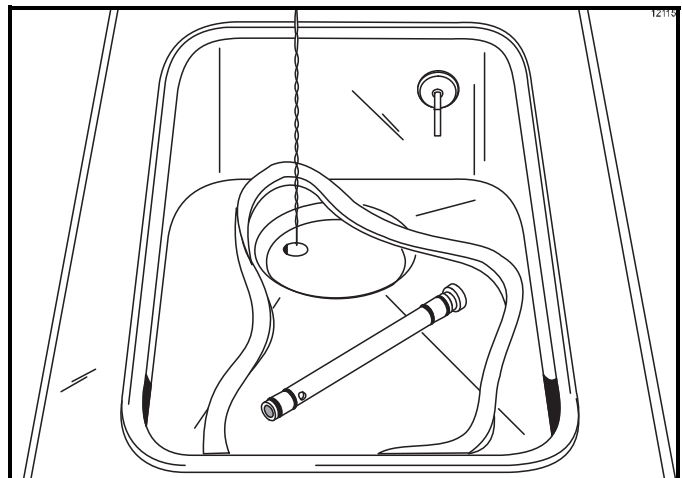

Figure 6-22

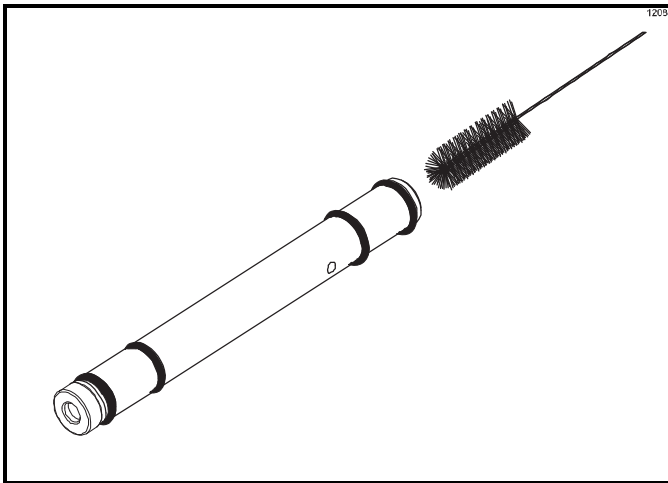

Figure 6-23

- Place the power switch in the ON position.

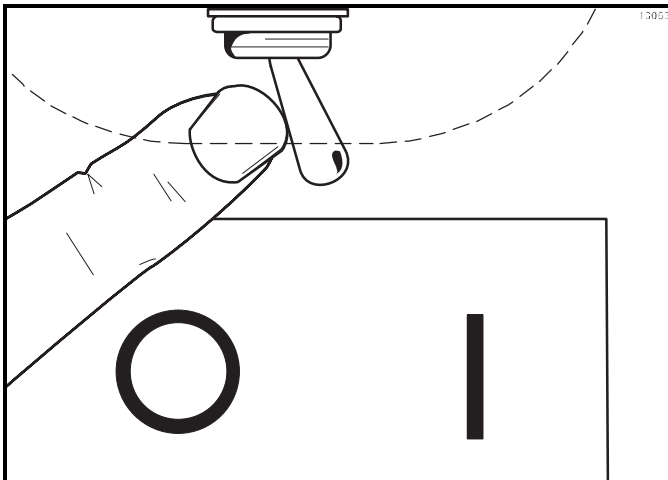

Figure 6-24

- Press the WASH button. This will cause the sanitizing solution in the freezing cylinder to agitate. Allow it to agitate for 5 minutes.

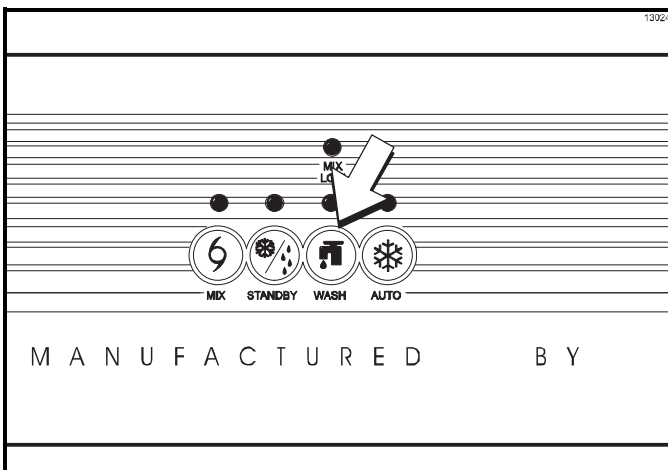

Figure 6-25

- Place an empty pail beneath the door spout and raise the prime plug.

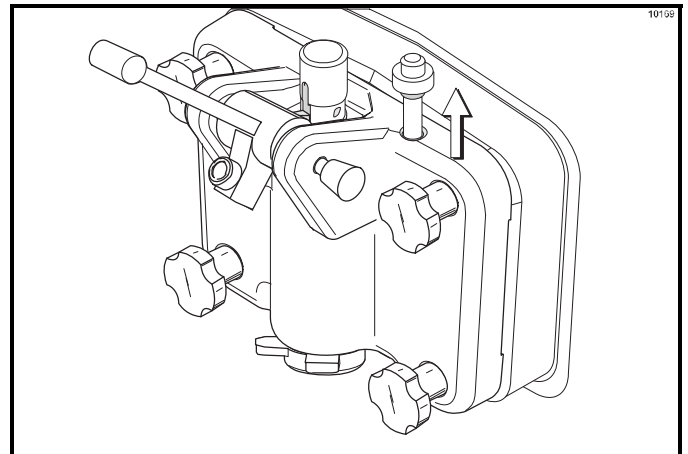

Figure 6-26

- When a **steady** stream of sanitizing solution is flowing from the prime plug opening in the bottom of the freezer door, lower the draw handle. Draw off all the sanitizing solution.

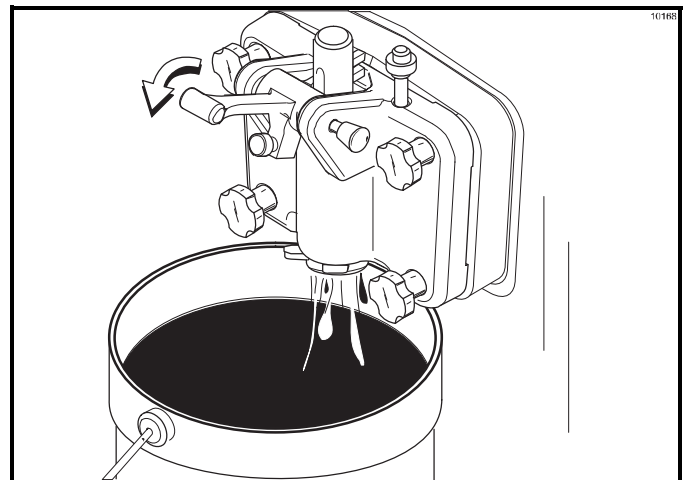

Figure 6-27

Note: On Models 754, 774, 791, and 794, momentarily pull the center draw handle down to sanitize the center door spout.

- Once the sanitizer stops flowing from the door spout, raise the draw handle and press the WASH button, canceling the beater motor operation.

Note: You have just sanitized the freezer. **Make sure your hands are sanitized** before continuing these instructions.

OPERATING PROCEDURES

- Assemble the hopper gasket around the top edge of the mix hopper. Stand the air tube in the corner of the hopper.

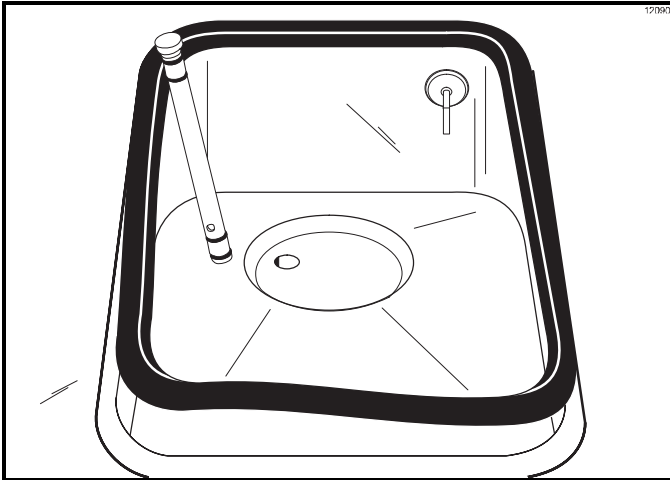

Figure 6-28

- Repeat Step 1 through Step 9 for the other side of the freezer on Models 754, 774, 791, and 794.

Priming

- With a pail beneath the door spout, lower the draw handle. Make sure the prime plug is still in the **up** position. Pour 2 gal. (7.6 L) of fresh mix into the mix hopper and allow it to flow into the freezing cylinder. This will force out any remaining sanitizing solution. When mix is flowing full-strength from the door spout, raise the draw handle.

Note: Use only fresh mix when priming the freezing cylinder.

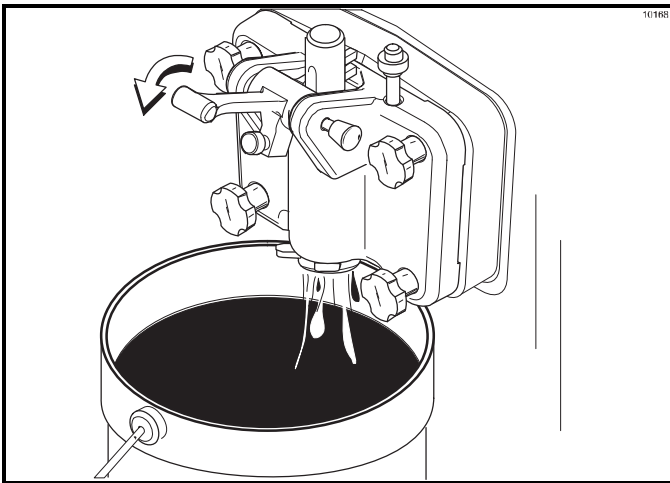

Figure 6-29

- Once a **steady** stream of mix starts to flow from the prime plug opening in the bottom of the freezer door, push down the prime plug.

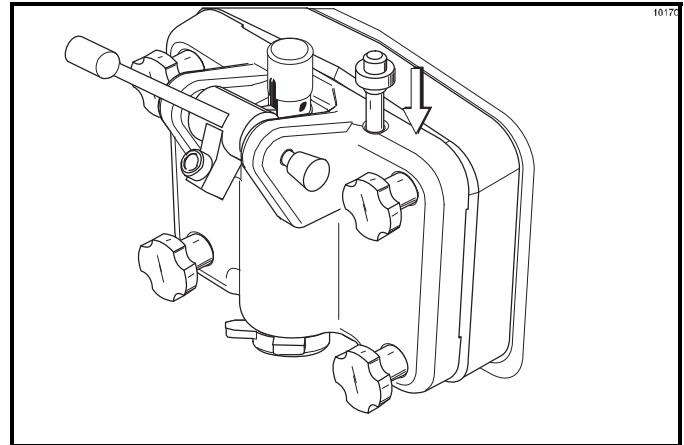

Figure 6-30

- Lubricate the O-rings on the air tube on the end with the small hole on the side.
- Install the air tube (the end with the hole) with the air orifice installed into the mix inlet hole in the mix hopper.
- Press the AUTO button. The AUTO light will come on, indicating the main refrigeration system is operating. When the unit cycles off, the product will be at serving viscosity.

Note: On Models 751, 754, 774, 791, and 794, the **MIX** light will come on, indicating the mix refrigeration system is operating to maintain the mix in the mix hopper.

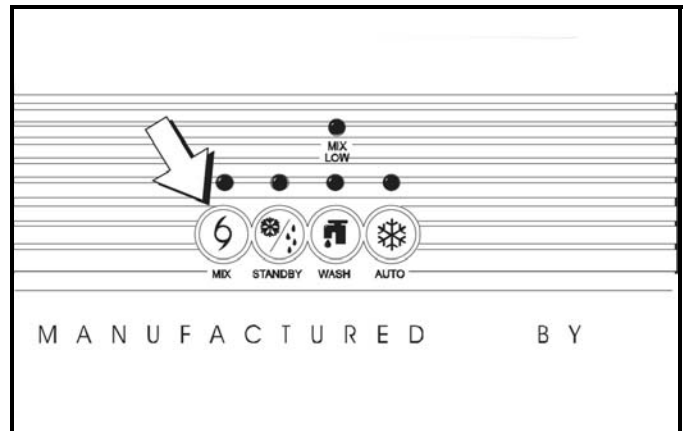

Figure 6-31

- Fill the hopper with mix. As the mix level comes in contact with the mix-level sensing probe on the rear wall of the hopper, the MIX LOW light will shut off.
- Place the mix hopper cover in position over the mix hopper.
- Repeat step 1 through step 7** for the other side of the freezer on Models 754, 774, 791, and 794.

Closing Procedure

To disassemble your machine, the following items will be needed:

- Two cleaning pails
- Sanitized stainless-steel rerun can with lid
- Necessary brushes (provided with freezer)
- Cleaner
- Single-service towels

Draining Product from the Freezing Cylinder

1. Press the AUTO button, canceling compressor and beater motor operation.
Press the MIX refrigeration button, canceling the mix hopper refrigeration system.
2. Remove the hopper cover, hopper gasket, and air tube. Take these parts to the sink for cleaning.
3. **If local health codes permit the use of rerun**, place a sanitized, NSF-approved stainless-steel rerun container beneath the door spout. Press the WASH button and lower the draw handle. Drain the remaining product from the freezing cylinder and mix hopper. When the flow of product stops, press the WASH button and raise the draw handle. Place the sanitized lid on the rerun container and place it in the walk-in cooler.

Note: *If local health codes do not permit the use of rerun, the product must be discarded. Drain the product into a pail and properly discard it.*

4. **Repeat step 1 through step 3** for the other side of the freezer on Models 754, 774, 791, and 794.



ALWAYS FOLLOW LOCAL HEALTH CODES.

Rinsing

1. Pour 2 gal. (7.6 L) of **cool** clean water into the mix hopper. With the brushes provided, scrub the mix hopper, mix inlet hole and mix-level sensing probe.
2. With a pail beneath the door spout, raise the prime plug and press the WASH button.

3. When a steady stream of rinse water is flowing from the prime plug opening in the bottom of the freezer door, lower the draw handle. Drain all the rinse water from the freezing cylinder, raise the draw handle and press the WASH button canceling the Wash mode.
4. **Repeat step 1 through step 3** for the other side of the freezer on models 754, 774, 791, and 794.

Cleaning

Note: *Use warm water and follow the manufacturer's specifications.*

1. Prepare an approved 100 ppm cleaning solution (examples: 2.5 gal. [9.5 L] of Kay-5[®] or 2 gal. [7.6 L] of Stera-Sheen[®]).
2. Push down the prime plug. Pour the cleaning solution into the mix hopper.
3. While the solution is flowing into the freezing cylinder, brush-clean the mix hopper, mix-level sensing probe, and the mix inlet hole.
4. Press the WASH button. This will cause the cleaning solution in the freezing cylinder to agitate.
5. Place an empty pail beneath the door spout and raise the prime plug.
6. When a steady stream of cleaning solution is flowing from the prime plug opening in the bottom of the freezer door, lower the draw handle. Draw off all of the solution.
7. Once the cleaner stops flowing from the door spout, raise the draw handle and press the WASH button canceling the Wash mode.
8. **Repeat step 1 through step 7** for the other side of the freezer on Models 754, 774, 791, and 794.

6

Disassembly



WARNING! Make sure the power switch is in the OFF position! Failure to follow this instruction may result in severe personal injury to fingers or hands from hazardous moving parts.

1. Remove the handscrews, freezer door(s), beater(s), scraper blades, and driveshaft(s) from the freezing cylinder(s). Take these parts to the sink for cleaning.
2. Remove the front drip tray and the splash shield.

Manual Brush-Cleaning

These procedures must be completed according to the frequency specified by your federal, state, or local regulatory agencies. Please consult your governing food code to determine the maximum number of days allowed between brush-clean cycles.

Use the recommended cleaning procedure outlined in the manual or an alternate procedure used in conjunction with a cleaning/sanitizing system that has been certified by NSF.



1. Prepare a sink with an approved cleaning solution (examples: Kay-5[®] or Stera-Sheen[®]).

Note: Use warm water and follow the manufacturer's specifications.

If another approved cleaner is used, dilute it according to the label instructions.

Important! Follow the label directions. Too **strong** of a solution can cause parts damage, while too **mild** of a solution will not provide adequate cleaning. Make sure all brushes provided with the freezer are available for brush-cleaning.

6

2. Remove the seal(s) from the driveshaft(s).

3. From the freezer door(s), remove:

- Gasket(s)
- Front bearing(s)
- Pivot pin(s)
- Adjustable draw handle(s)
- Design cap(s)
- Draw valve(s)
- Prime plug(s)
- All O-rings

Note: To remove O-rings, use a single-service towel to grasp the O-ring. Apply pressure upward until the O-ring pops out of its groove. With the other hand, push the top of the O-ring forward. It will roll out of the groove and can be easily removed. If there is more than one O-ring to be removed, always remove the rear O-ring first. This will allow the O-ring to slide over the forward rings without falling into the open grooves.

4. Remove the O-rings from the air tube(s) and air orifice(s).
5. Return to the freezer with a small amount of cleaning solution. Brush-clean the rear shell bearing(s) at the back of the freezing cylinder(s) with the black brush.

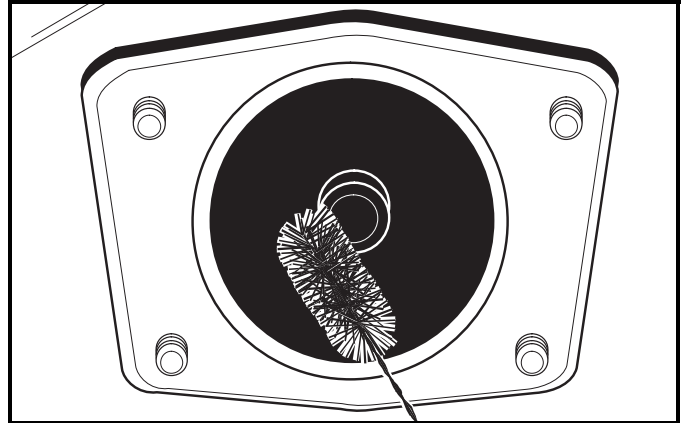

Figure 6-32

6. Remove the rear drip pan(s) and take to the sink for cleaning.

Note: If the drip pan is filled with an excessive amount of mix, refer to the Troubleshooting Guide.

7. Thoroughly brush-clean all disassembled parts in the cleaning solution, making sure all lubricant and mix film is removed. Take particular care to brush-clean the draw valve core(s) in the freezer door. Place all the cleaned parts on a clean, dry surface to air-dry overnight.
8. Wipe clean all exterior surfaces of the freezer.

During Cleaning and Sanitizing

Important! Cleaning and sanitizing schedules are governed by federal, state, or local regulatory agencies, and must be followed accordingly. If the machine has a Standby mode, it must not be used instead of proper cleaning and sanitizing procedures and frequencies set forth by the ruling health authority. The following checkpoints should be stressed during the cleaning and sanitizing operations.



IMPORTANT! Cleaning and sanitizing must be performed daily.



ALWAYS FOLLOW LOCAL HEALTH CODES.

Troubleshooting Bacterial Count

- Thoroughly clean and sanitize machine regularly, including complete disassembly and brush-cleaning.
- Use all brushes supplied for thorough cleaning. The brushes are specially designed to reach all mix passageways.
- Use the white bristle brush to clean the mix inlet hole that extends from the mix hopper down to the rear of the freezing cylinder.
- Use the black bristle brush to thoroughly clean the rear shell bearing located at the rear of the freezing cylinder. Use a generous amount of cleaning solution on the brush.
- If local health codes permit the use of rerun, make sure the mix rerun is stored in a sanitized, covered stainless-steel container and used the following day. **Do not** prime the machine with rerun. When using rerun, skim off the foam and discard. Mix it with fresh mix in a ratio of 50:50 during the days operation.

- On a designated day of the week, run the mix as low as feasible and discard it after closing. This will break the rerun cycle and reduce the possibility of high bacteria and coliform counts.
- Properly prepare the cleaning and sanitizing solutions. Read and follow label directions carefully. Too **strong** of a solution may damage the parts, and too **weak** of a solution will not do an adequate job of cleaning or sanitizing.
- The temperature of the mix in the mix hopper and walk-in cooler should be below 40°F (4.4°C).

Regular Maintenance Checks

- Replace scraper blades that are nicked or damaged. Before installing the beater assembly, make sure that scraper blades are properly attached to the helix.
- Check the rear shell bearing for signs of wear (excessive mix leakage in rear drip pan) and make sure it is properly cleaned.
- Using a screwdriver and cloth towel, clean the rear shell bearing and the 3/4 hex drive coupling free of lubricant and mix deposits.
- Dispose of O-rings and seals if they are worn, torn, or fit too loosely, and replace them with new ones.
- Follow all lubricating procedures as outlined in "Assembly" on page 6-1.

Important! Never use screwdrivers or other metal probes to clean between the fins.

- If your machine is air-cooled, check the condensers for dirt and lint. Dirty condensers will reduce the efficiency and capacity of the machine. Condensers should be cleaned monthly with a soft brush.

Note: For machines equipped with an air filter, it will be necessary to vacuum-clean the filters monthly.



WARNING! Always disconnect electrical power prior to cleaning the condenser. Failure to follow this instruction may result in electrocution.

OPERATOR'S CHECKLIST

- If your machine is equipped with an auxiliary refrigeration system, check the auxiliary condenser for dirt and lint. Dirty condensers will reduce the refrigeration capacity of the mix hopper. Condensers must be cleaned monthly with a soft brush. **Never use screwdrivers or other metal probes to clean between the fins.** Failure to follow this instruction may result in electrocution.



WARNING! Always disconnect electrical power prior to cleaning the condenser. Failure to follow this instruction may result in electrocution.

- If your machine is water-cooled, check the water lines for kinks or leaks. Kinks can occur when the machine is moved back and forth for cleaning or maintenance. Deteriorated or cracked water lines should be replaced only by an authorized Taylor distributor.

Winter Storage

If the place of business is to be closed during the winter months, it is important to protect the freezer by following certain precautions, particularly if the building is subject to freezing conditions.

- Disconnect the freezer from the main power source to prevent possible electrical damage.
- On water-cooled freezers, disconnect the water supply. Relieve pressure on the spring in the water valve. Use air pressure on the outlet side to blow out any water remaining in the condenser. **This is extremely important.** Failure to follow this procedure may cause severe and costly damage to the refrigeration system.
- Your local Taylor distributor can perform this winter storage service for you.
- Wrap detachable parts of the freezer such as beater, blades, driveshaft, and freezer door, and place them in a protected dry place. Rubber trim parts and gaskets can be protected by wrapping them with moisture-proof paper. All parts should be thoroughly cleaned of dried mix or lubrication, which can attract mice and other vermin.

Table 8-1

Problem	Probable Cause	Remedy	Page Ref.
1. No product is being dispensed with draw valve open and the machine in the Auto mode.	a. Freeze-up in mix inlet hole.	a. Call service technician to adjust the mix hopper temperature.	---
	b. Beater motor out on reset.	b. Reset the freezer.	5-3
	c. The beater is rotating counterclockwise from the operator end.	c. Contact service technician to correct rotation to clockwise from operator end.	---
	d. The circuit breaker is off, or the fuse is blown.	d. Turn the breaker on, or replace the fuse.	---
	e. There is inadequate mix in the mix hopper.	e. Fill the mix hopper with mix.	6-8
	f. The air orifice is not installed.	f. Install air orifice in air tube.	6-8
2. The product is too stiff.	a. The viscosity needs adjustment.	a. Contact service technician.	---
	b. The air orifice is not installed.	b. Install air orifice in air tube.	6-8
3. The product is too soft.	a. Viscosity needs adjustment.	a. Contact service technician.	---
	b. Not enough airspace around the machine. (air-cooled machines)	b. Allow for adequate airflow across the condenser.	3-2
	c. Worn scraper blades.	c. Replace regularly.	9-1
	d. Dirty condenser (A/C).	d. Clean monthly.	7-1
	e. Mix is out of date.	e. Use only fresh mix.	---
	f. Loss of water (W/C).	f. Locate cause of water loss and correct.	7-2
4. The mix in the mix hopper is too cold.	a. The temperature is out of adjustment.	a. Call service technician to adjust the mix hopper temperature.	---
5. The mix in the mix hopper is too warm.	b. The temperature is out of adjustment.	b. Call service technician to adjust the mix hopper temperature.	---
	c. Missing or worn mix hopper gasket.	c. Replace/install the gasket around the mix hopper.	6-8
	d. The mix hopper cover is not in position.	d. Place the cover in position.	6-8
	e. The MIX light is not lit.	e. Press the MIX button.	5-2
6. The driveshaft is stuck in the drive coupling.	a. Rounded corners of driveshaft, coupling, or both.	a. Call service technician to correct cause and replace the necessary components. Do not lubricate the hex end of the driveshaft.	---
	b. Mix and lubricant collected in the drive coupling.	b. Brush-clean the rear shell bearing area regularly.	6-10

TROUBLESHOOTING GUIDE

Problem	Probable Cause	Remedy	Page Ref.
7. The freezing cylinder walls are scored.	a. The beater assembly is bent.	a. Call service technician to repair or replace the beater and to correct the cause of insufficient mix in the freezing cylinder.	- - -
	b. The front bearing is missing or worn on the freezer door.	b. Install or replace the front bearing.	6-2
8. Excessive mix leakage into the rear drip pan.	a. Missing or worn driveshaft seal on driveshaft.	a. Install or replace regularly.	6-1/9-1
	b. The rear shell bearing is worn.	b. Call service technician to replace rear shell bearing.	- - -
9. Excessive mix leakage from door spout.	a. Missing or worn draw valve O-rings.	a. Install or replace regularly.	6-4/9-1
	b. Inadequate lubrication of draw valve O-rings.	b. Lubricate properly.	6-4
	c. Wrong type of lubricant is being used (example: petroleum-base lubricant).	c. Use the proper lubricant (example: Taylor Lube).	6-1
10.No freezer operation after pressing the AUTO button.	a. Machine is unplugged.	a. Plug into wall receptacle.	- - -
	b. The circuit breaker is off, or the fuse is blown.	b. Turn the breaker on, or replace the fuse.	- - -
	c. The beater motor is out on reset.	c. Reset the freezer.	5-3
11.Product is not feeding into the freezing cylinder.	a. Inadequate level of mix in the mix hopper.	a. Fill the mix hopper with mix.	6-8
	b. The mix inlet hole is frozen up.	b. The mix hopper temperature needs adjustment. Call service technician.	- - -
	c. The air tube is installed incorrectly.	c. Install the air tube in the mix inlet hole, using the end with the small hole in the side.	6-8
	d. The air orifice is not installed.	d. Install the air orifice in the air tube.	6-8

Maintenance Intervals

Table 9-1

Part Description	Every 3 Months	Every 6 Months	Annually
Driveshaft Seal	X		
Scraper Blade	X		
Freezer Door Gasket	X		
Front Bearing	X		
Draw Valve O-ring	X		
Pivot Pin O-ring	X		
Prime Plug O-ring	X		
Air Tube O-ring	X		
Air Orifice O-ring	X		
White Bristle Brush, 3" x 7"		Inspect and replace if necessary.	Minimum
White Bristle Brush, 1" x 2"		Inspect and replace if necessary.	Minimum
Black Bristle Brush, 1" x 2"		Inspect and replace if necessary.	Minimum
Double-Ended Brush		Inspect and replace if necessary.	Minimum

TAYLOR COMPANY LIMITED WARRANTY ON FREEZERS

Taylor Company is pleased to provide this limited warranty on new Taylor-branded freezer equipment (the "Product") available from Taylor to the market generally to the original purchaser only.

LIMITED WARRANTY

Taylor warrants the Product against failure due to defects in materials or workmanship under normal use and service as follows. All warranty periods begin on the date of original Product installation. If a part fails due to defects during the applicable warranty period, Taylor, through an authorized Taylor distributor or service agency, will provide a new or remanufactured part, at Taylor's option, to replace the failed defective part at no charge for the part. Except as otherwise stated herein, these are Taylor's exclusive obligations under this limited warranty for a Product failure. This limited warranty is subject to all provisions, conditions, limitations, and exclusions listed below and on the reverse (if any) of this document.

Table 10-1

Product	Part	Limited Warranty Period
Soft Serve	Insulated shell assembly	Five (5) years
Frozen Yogurt and Shakes	Refrigeration Compressor (except service valve)	Five (5) years
Smoothies	Beater motors	Two (2) years
Frozen Beverage	Beater drive gear	Two (2) years
Batch Desserts	Printed circuit boards and Softech™ controls beginning with serial number H8024200	Two (2) years
	Parts not otherwise listed in this table or excluded below	One (1) year

LIMITED WARRANTY CONDITIONS

1. If the date of original installation of the Product cannot be verified, then the limited warranty period begins ninety (90) days from the date of Product manufacture (as indicated by the Product serial number). Proof of purchase may be required at time of service.
2. This limited warranty is valid only if the Product is installed and all required service work on the Product is performed by an authorized Taylor distributor or service agency, and only if genuine, new Taylor parts are used.
3. Installation, use, care, and maintenance must be normal and in accordance with all instructions contained in the Taylor Operator's Manual.
4. Defective parts must be returned to the authorized Taylor distributor or service agency for credit.
5. The use of any refrigerant other than that specified on the Product's data label will void this limited warranty.

LIMITED WARRANTY ON EQUIPMENT

LIMITED WARRANTY EXCEPTIONS

This limited warranty does **not** cover:

1. Labor or other costs incurred for diagnosing, repairing, removing, installing, shipping, servicing, or handling of defective parts, replacement parts, or new products.
2. Normal maintenance, cleaning, and lubrication as outlined in the Taylor Operator's Manual, including cleaning of condensers.
3. Replacement of wear items designated as Class 000 parts in the Taylor Operator's Manual.
4. External hoses, electrical power supplies, and machine grounding.
5. Parts not supplied or designated by Taylor, or damages resulting from their use.
6. Return trips or waiting time required because a service technician is prevented from beginning warranty service work promptly upon arrival.
7. Failure, damage, or repairs due to faulty installation, misapplication, abuse, no or improper servicing, unauthorized alteration, or improper operation or use as indicated in the Taylor Operator's Manual, including but not limited to the failure to use proper assembly and cleaning techniques, tools, or approved cleaning supplies.
8. Failure, damage, or repairs due to theft, vandalism, wind, rain, flood, high water, water, lightning, earthquake, or any other natural disaster, fire, corrosive environments, insect or rodent infestation, or other casualty, accident, or condition beyond the reasonable control of Taylor; operation above or below the electrical or water supply specification of the Product; components repaired or altered in any way so as, in the judgment of the Manufacturer, to adversely affect performance, or normal wear or deterioration.
9. Any Product purchased over the Internet.
10. Failure to start due to voltage conditions, blown fuses, open circuit breakers, or damages due to the inadequacy or interruption of electrical service.
11. Electricity or fuel costs, or increases in electricity or fuel costs for any reason whatsoever.
12. Damages resulting from the use of any refrigerant other than that specified on the Product's data label.
13. Any cost to replace, refill, or dispose of refrigerant, including the cost of refrigerant.
14. **ANY SPECIAL, INDIRECT, OR CONSEQUENTIAL PROPERTY OR COMMERCIAL DAMAGE OF ANY NATURE WHATSOEVER.** Some jurisdictions do not allow the exclusion of incidental or consequential damages, so this limitation may not apply to you.

This limited warranty gives you specific legal rights, and you may also have other rights which vary from jurisdiction to jurisdiction.

LIMITATION OF WARRANTY

THIS LIMITED WARRANTY IS EXCLUSIVE AND IS IN LIEU OF ALL OTHER WARRANTIES, CONDITIONS, AND/OR REMEDIES UNDER THE LAW, INCLUDING ANY IMPLIED WARRANTIES OR CONDITIONS OF MERCHANTABILITY OR FITNESS FOR A PARTICULAR PURPOSE. THE ORIGINAL OWNER'S SOLE REMEDY WITH RESPECT TO ANY PRODUCTS SHALL BE REPAIR OR REPLACEMENT OF DEFECTIVE COMPONENTS UNDER THE TERMS OF THIS LIMITED WARRANTY. ALL RIGHTS TO CONSEQUENTIAL OR INCIDENTAL DAMAGES (INCLUDING CLAIMS FOR LOST SALES, LOST PROFITS, PRODUCT LOSS, PROPERTY DAMAGES, OR SERVICE EXPENSES) ARE EXPRESSLY EXCLUDED. THE EXPRESS WARRANTIES MADE IN THIS LIMITED WARRANTY MAY NOT BE ALTERED, ENLARGED, OR CHANGED BY ANY DISTRIBUTOR, DEALER, OR OTHER PERSON, WHATSOEVER.

LEGAL REMEDIES

The owner **must** notify Taylor in writing by certified or registered letter to the following address of any defect or complaint with the Product, stating the defect or complaint and a specific request for repair, replacement, or other correction of the Product under warranty, mailed at least thirty (30) days before pursuing any legal rights or remedies.

Taylor Company
750 N. Blackhawk Blvd.
Rockton, IL 61072, U.S.A.

TAYLOR COMPANY LIMITED WARRANTY ON TAYLOR GENUINE PARTS

Taylor Company is pleased to provide this limited warranty on new Taylor genuine replacement components and parts (the "Parts") available from Taylor to the market generally to the original purchaser only.

LIMITED WARRANTY

Taylor warrants the Parts against failure due to defect in materials or workmanship under normal use and service as follows. All warranty periods begin on the date of original installation of the Part in the Taylor unit. If a Part fails due to defects during the applicable warranty period, Taylor, through an authorized Taylor distributor or service agency, will provide a new or remanufactured Part, at Taylor's option, to replace the failed defective Part at no charge for the Part. Except as otherwise stated herein, these are Taylor's exclusive obligations under this limited warranty for a Part failure. This limited warranty is subject to all provisions, conditions, limitations, and exclusions listed below and on the reverse (if any) of this document.

Table 11-1

Parts Warranty Class Code or Part	Limited Warranty Period
Class 103 Parts ¹	Three (3) months
Class 212 Parts ²	Twelve (12) months
Class 512 Parts	Twelve (12) months
Class 000 Parts	No warranty
Taylor Part #072454 (Motor-24VDC *C832/C842*)	Four (4) years

LIMITED WARRANTY CONDITIONS

1. If the date of original installation of the Part cannot be otherwise verified, proof of purchase may be required at time of service.
2. This limited warranty is valid only if the Part is installed and all required service work in connection with the Part is performed by an authorized Taylor distributor or service agency.
3. The limited warranty applies only to Parts remaining in use by their original owner at their original installation location in the unit of original installation.
4. Installation, use, care, and maintenance must be normal and in accordance with all instructions contained in the Taylor Operator's Manual.
5. Defective parts must be returned to the authorized Taylor distributor or service agency for credit.
6. This warranty is not intended to shorten the length of any warranty coverage provided pursuant to a separate Taylor Limited Warranty on freezer or grill equipment.
7. The use of any refrigerant other than that specified for the unit in which the Part is installed will void this limited warranty.

^{1, 2} Except that Taylor Part #032129SER2 (Compressor-Air-230V SERV) and Taylor Part #075506SER1 (Compressor-Air-115V 60HZ) shall have a limited warranty period of twelve (12) months when used in Taylor freezer equipment and a limited warranty period of two (2) years when used in Taylor grill equipment.

LIMITED WARRANTY ON PARTS

LIMITED WARRANTY EXCEPTIONS

This limited warranty does **not** cover:

1. Labor or other costs incurred for diagnosing, repairing, removing, installing, shipping, servicing, or handling of defective Parts, replacement Parts, or new Parts.
2. Normal maintenance, cleaning, and lubrication as outlined in the Taylor Operator's Manual, including cleaning of condensers or carbon and grease buildup.
3. Required service, whether cleaning or general repairs, to return the cooking surface assemblies, including the upper platen and lower plate, to an operational condition to achieve proper cooking or allow proper assembly of release sheets and clips as a result of grease build-up on the cooking surfaces, including but not limited to the platen and plate, sides of the shroud, or top of the shroud.
4. Replacement of cooking surfaces, including the upper platen and lower plate, due to pitting or corrosion (or in the case of the upper platen, due to loss of plating) as a result of damage due to the impact of spatulas or other small wares used during the cooking process or as a result of the use of cleaners, cleaning materials, or cleaning processes not approved for use by Taylor.
5. Replacement of wear items designated as Class 000 Parts in the Taylor Operator's Manual, as well as any release sheets and clips for the Product's upper platen assembly.
6. External hoses, electrical power supplies, and machine grounding.
7. Parts not supplied or designated by Taylor, or damages resulting from their use.
8. Return trips or waiting time required because a service technician is prevented from beginning warranty service work promptly upon arrival.
9. Failure, damage, or repairs due to faulty installation, misapplication, abuse, no or improper servicing, unauthorized alteration, or improper operation or use as indicated in the Taylor Operator's Manual, including but not limited to the failure to use proper assembly and cleaning techniques, tools, or approved cleaning supplies.
10. Failure, damage, or repairs due to theft, vandalism, wind, rain, flood, high water, water, lightning, earthquake, or any other natural disaster, fire, corrosive environments, insect or rodent infestation, or other casualty, accident or condition beyond the reasonable control of Taylor; operation above or below the gas, electrical, or water supply specification of the unit in which a part is installed; Parts or the units in which they are installed repaired or altered in any way so as, in the judgment of Taylor, to adversely affect performance, or normal wear or deterioration.
11. Any Part purchased over the Internet.
12. Failure to start due to voltage conditions, blown fuses, open circuit breakers, or damages due to the inadequacy or interruption of electrical service.
13. Electricity, gas, or other fuel costs, or increases in electricity or fuel costs for any reason whatsoever.
14. Damages resulting from the use of any refrigerant other than that specified for the unit in which the Part is installed.
15. Any cost to replace, refill, or dispose of refrigerant, including the cost of refrigerant.
16. **ANY SPECIAL, INDIRECT, OR CONSEQUENTIAL PROPERTY OR COMMERCIAL DAMAGE OF ANY NATURE WHATSOEVER.** Some jurisdictions do not allow the exclusion of incidental or consequential damages, so this limitation may not apply to you.

This limited warranty gives you specific legal rights, and you may also have other rights which vary from jurisdiction to jurisdiction.

LIMITATION OF WARRANTY

THIS LIMITED WARRANTY IS EXCLUSIVE AND IS IN LIEU OF ALL OTHER WARRANTIES, CONDITIONS, AND/OR REMEDIES UNDER THE LAW, INCLUDING ANY IMPLIED WARRANTIES OR CONDITIONS OF MERCHANTABILITY OR FITNESS FOR A PARTICULAR PURPOSE. THE ORIGINAL OWNER'S SOLE REMEDY WITH RESPECT TO ANY PRODUCTS SHALL BE REPAIR OR REPLACEMENT OF DEFECTIVE PARTS UNDER THE TERMS OF THIS LIMITED WARRANTY. ALL RIGHTS TO CONSEQUENTIAL OR INCIDENTAL DAMAGES (INCLUDING CLAIMS FOR LOST SALES, LOST PROFITS, PRODUCT LOSS, PROPERTY DAMAGES, OR SERVICE EXPENSES) ARE EXPRESSLY EXCLUDED. THE EXPRESS WARRANTIES MADE IN THIS LIMITED WARRANTY MAY NOT BE ALTERED, ENLARGED, OR CHANGED BY ANY DISTRIBUTOR, DEALER, OR OTHER PERSON, WHATSOEVER.

LEGAL REMEDIES

The owner **must** notify Taylor in writing by certified or registered letter to the following address of any defect or complaint with the Part, stating the defect or complaint and a specific request for repair, replacement, or other correction of the Part under warranty, mailed at least thirty (30) days before pursuing any legal rights or remedies.

Taylor Company
750 N. Blackhawk Blvd.
Rockton, IL 61072, U.S.A.

