

OPERATOR'S MANUAL



Model 8752, 8756 and 8757 Soft-Serve Freezers

Original Operating Instructions

028752-M

08/99 (Original Publication)
(Updated 8/11/2020)

Complete this page for quick reference when service is required:

Taylor Distributor: _____

Address: _____

Phone: _____

Service: _____

Parts: _____

Date of Installation: _____

Information found on the data label:

Model Number: _____

Serial Number: _____

Electrical Specs: Voltage _____ Cycle _____

 Phase _____

Maximum Fuse Size: _____ Amps

Minimum Wire Ampacity: _____ Amps

Note: Continuing research results in steady improvements; therefore, information in this manual is subject to change without notice.

Note: Only instructions originating from the factory or its authorized translation representative(s) are considered to be the original set of instructions.

© May, 2009 Taylor Company

(Updated 8/11/2020)

028752-M

Any unauthorized reproduction, disclosure, or distribution of copies by any person of any portion of this work may be a violation of copyright law of the United States of America and other countries, could result in the awarding of statutory damages of up to \$250,000 (17 USC 504) for infringement, and may result in further civil and criminal penalties.

All rights reserved.



Taylor Company
750 N. Blackhawk Blvd.
Rockton, IL 61072

Section 1: To the Installer

Installer Safety	1-1
Site Preparation	1-1
Air-Cooled Machines	1-2
Water Connections	1-2
Electrical Connections	1-2
Beater Rotation	1-3
Refrigerant	1-3

Section 2: To the Operator

Compressor Warranty Disclaimer	2-2
--	-----

Section 3: Safety

Section 4: Operator Parts Identification

Model 8752	4-1
Model 8752 Beater Door Assembly	4-3
Model 8756	4-4
Model 8757	4-6
8756 and 8757 Beater Door Assembly	4-8
Accessories	4-9

Section 5: User Interface

Symbol Definitions	5-2
Power Switch	5-2
RESET Button	5-2
Softech™ Control Operation	5-2
Adjustable Draw Handle	5-3

Section 6: Operating Procedures

Prior to Setup (Model 8757)	6-1
Assembly	6-1
Air/Mix Pump Assembly Exploded View	6-9
Sanitizing	6-10
Priming	6-12
Closing Procedure	6-13
Draining Product from the Freezing Cylinder	6-13
Rinsing	6-14
Cleaning	6-14
Disassembly	6-14
Brush-Cleaning	6-15
Check Topping Pump Temperature and Volume - Model 8757	6-16

Table of Contents

Section 7: Operator Checklist

During Cleaning and Sanitizing	7-1
Troubleshooting Bacterial Count	7-1
Regular Maintenance Checks.	7-1
Air/Mix Pump	7-2
Winter Storage	7-2

Section 8: Troubleshooting Guide

Section 9: Parts Replacement Schedule

Section 10: Machine Limited Warranty

Section 11: Limited Warranty on Parts

The following information has been included in the manual as safety and regulatory guidelines. For complete installation instructions, please see the Installation Checklist.

Installer Safety



IMPORTANT! In all areas of the world, machines should be installed in accordance with existing local codes. Please contact your local authorities if you have any questions.

Care should be taken to ensure that all basic safety practices are followed during the installation and servicing activities related to the installation and service of Taylor® machines.

- Only Taylor service personnel should perform installation, maintenance, and repairs on Taylor machines.
- Authorized service personnel should consult OSHA Standard 29CFR1910.147 or the applicable code of the local area for industry standards on lockout/tagout procedures before beginning any installation or repairs.
- Authorized service personnel must ensure that the proper personal protective equipment (PPE) is available and worn when required during installation and service.
- Authorized service personnel must remove all metal jewelry, rings, and watches before working on electrical equipment.



DANGER! The main power supply(s) to the machine must be disconnected prior to performing any installation, maintenance, or repairs. Failure to follow this instruction may result in personal injury or death from electrical shock or hazardous moving parts as well as poor performance or damage to the machine.



WARNING! This machine has many sharp edges that can cause severe injuries.

Site Preparation

Review the area where the machine will be installed before uncrating the machine. Make sure all possible hazards to the user or machine have been addressed.



WARNING! Only install this machine in a location where its use and maintenance is restricted to trained personnel. Failure to comply may result in personal injury.

For Indoor Use Only: This machine is designed to operate indoors, under normal ambient temperatures of 70°F to 75°F (21°C to 24°C). The freezer has successfully performed in high ambient temperatures of 104°F (40°C) at reduced capacities.



WARNING! This machine must **NOT** be installed in an area where a water jet or hose can be used. **NEVER** use a water jet or hose to rinse or clean the unit. Failure to follow this instruction may result in electrocution.



CAUTION! This machine must be installed on a level surface to avoid the hazard of tipping. Extreme care should be taken in moving this equipment for any reason. Two or more persons are required to safely move this machine. Failure to comply may result in personal injury or machine damage.

Uncrate the machine and inspect it for damage. Report any damage to your Taylor distributor.

This machine is made in the USA and has USA sizes of hardware. All metric conversions are approximate and vary in size.

Air-Cooled Machines

Important! Do not obstruct air intake and discharge openings.

Air-cooled machines require a minimum of 3 in. (76 mm) of clearance around all sides of the freezer and 12 in. (305 mm) on the top of the freezer to allow for adequate air flow across the condenser(s). Failure to allow adequate clearance can reduce the refrigeration capacity of the freezer and possibly cause permanent damage to the compressor.

Water Connections

(Water-Cooled Machines Only)

An adequate cold water supply must be provided with a hand shutoff valve. On the underside rear of the base pan, two 3/8 in. IPS (for single-head machines) or two 1/2 in. IPS (for double-head machines) water connections for inlet and outlet have been provided for easy hookup. Permanently connect the machine using 1/2 in. (12.7 mm) inside diameter water lines. (Flexible lines are recommended, if local codes permit.)

Depending on local water conditions, it may be advisable to install a water strainer to prevent foreign substances from clogging the automatic water valve. There will be only one water-in and one water-out connection for both single-head and double-head machines.

Do not install a hand shutoff valve on the water-out line. Water should always flow in this order: first, through the automatic water valve; second, through the condenser; and third, through the outlet fitting to an open trap drain.



IMPORTANT! A backflow prevention device is required on the incoming water connection side. Please see the applicable national, state, and local codes for determining the proper configuration. Water pressure to the unit must not exceed 150 psi (1034 kPa).

Electrical Connections



IMPORTANT! In the United States, this machine is intended to be installed in accordance with the National Electrical Code (NEC), ANSI/NFPA 701987. The purpose of the NEC code is the practical safeguarding of persons and property from hazards arising from the use of electricity. This code contains provisions considered necessary for safety.

In all other areas of the world, the machine should be installed in accordance with the existing local codes. Please contact your local authorities if you have any questions.

Each machine requires one power supply for each data label on the machine. Check the data label(s) on the machine for branch circuit overcurrent protection or fuse, circuit ampacity, and other electrical specifications.

See the wiring diagram provided inside the electrical box for proper power connections.



FOLLOW YOUR LOCAL ELECTRICAL CODES.



WARNING! This equipment must be properly grounded. Failure to do so can result in severe personal injury from electrical shock.



IMPORTANT! An equipotential grounding lug is provided with this machine. Some countries require the grounding lug to be properly attached to the rear of the frame by the authorized installer. The installation location is marked by the equipotential bonding symbol (5021 of IEC 60417-1) on both the removable panel and the machine's frame.



WARNING! Avoid injury.

- **DO NOT** operate the machine unless it is properly grounded.
- **DO NOT** operate the machine with fuses larger than specified on the machine's data label.
- All repairs should be performed by an authorized Taylor service technician.
- The main power supplies to the machine must be disconnected prior to performing installation, repairs, or maintenance.
- **For Cord-Connected Machines:** Only Taylor service technicians or licensed electricians may install a plug or replacement cord on the machine.
- Machines that are permanently connected to fixed wiring and for which leakage currents may exceed 10 mA, particularly when disconnected or not used for long periods, or during initial installation, shall have protective devices to protect against the leakage of current, such as a GFI, installed by the authorized personnel to local codes.
- Stationary machines that are not equipped with a power cord and a plug or another device to disconnect the appliance from the power source must have an all-pole disconnecting device with a contact gap of at least 0.125 in. (3 mm) in the external installation.
- Supply cords used with this machine shall be oil-resistant, sheathed flexible cable not lighter than ordinary polychloroprene or other equivalent synthetic elastomer-sheathed cord (code designation 60245 IEC 57) installed with the proper cord anchorage to relieve conductors from strain, including twisting, at the terminals and protect the insulation of the conductors from abrasion.
- If the supply cord is damaged, it must be replaced by the manufacturer, service agent, or a similarly qualified person to avoid a hazard.
- Secure supply cord ground lead to machine in a location where if the cord is pulled the main power leads become taut before the ground lead can break loose.

Failure to follow these instructions may result in

electrocution. Contact your local authorized Taylor distributor for service.

Beater Rotation



NOTICE! Beater rotation must be clockwise as viewed looking into the freezing cylinder.

Electrical connections are made directly to the terminal block provided in the splice box which is mounted on the base pan on the right side of the freezer for Model 8752 and located in the splice boxes which are mounted mid-level on the frame channel on the right and left sides for Models 8756 and 8757.

Refrigerant



CAUTION! This equipment contains fluorinated greenhouse gases (F-Gas) to provide refrigeration using a hermetically sealed circuit or within foam insulation. This unit's type of gas, quantity, Global Warming Potential (GWP) and CO2 tonnes equivalent information is recorded on the unit's data-label. The refrigerant used is generally considered non-toxic and non-flammable. However any gas under pressure is potentially hazardous and must be handled with caution.

NEVER fill any refrigerant cylinder completely with liquid. Filling a cylinder to approximately 80% will allow for normal expansion.



CAUTION! Use only approved refrigerant listed on the machine's data label or authorized through a manufacturer's technical bulletin. The use of any other refrigerant may expose users and operators to unexpected safety hazards..



WARNING! Refrigerant liquid sprayed onto the skin may cause serious damage to tissue. Keep eyes and skin protected. If refrigerant burns should occur, flush immediately with cold water. If burns are severe, apply ice packs and contact a physician immediately.



NOTICE! Taylor reminds technicians to be aware of and in compliance with local government laws regarding refrigerant recovery, recycling, and reclaiming systems. For information regarding applicable local laws, please contact your local authorized Taylor distributor.

1



IMPORTANT! *Refrigerants and their associated lubricants may be extremely moisture absorbent. When opening a refrigeration system, the maximum time the system is open must not exceed 15 minutes. Cap all open tubing to prevent humid air or water from being absorbed by the oil.*

The machine you have purchased has been carefully engineered and manufactured to give you dependable operation. Taylor products are highly sophisticated and, when properly operated and cared for, will produce a consistent quality product. Like all mechanical products, they will require cleaning and maintenance. A minimum amount of care and attention is necessary if the operating procedures outlined in this manual are followed closely.



IMPORTANT! This manual should be read before operating or performing any maintenance on the machine.

Your Taylor machine will **NOT** compensate for and/or correct any errors made during setup or filling operations. Thus, the initial assembly, setup, and priming procedures are of extreme importance. It is strongly recommended that all personnel responsible for the machine's operation, including assembly and disassembly, go through these procedures together to be properly trained and to make sure that all personnel understand their role in using and maintaining the machine.

If you require technical assistance, please contact your local authorized Taylor distributor.

Note: Your Taylor warranty is valid only if the parts are authorized Taylor parts, purchased from the local authorized Taylor distributor, and only if all required service work is provided by a Taylor service technician. Taylor reserves the right to deny warranty claims on machines or parts if unapproved parts or incorrect refrigerant were installed in the machine, system modifications were performed beyond factory recommendations, or it is determined that the failure was caused by abuse, misuse, neglect, or failure to follow all operating instructions. For full details of your Taylor warranty, please see the Limited Warranty section in this manual.

Note: Constant research results in steady improvements; therefore, information in this manual is subject to change without notice.



IMPORTANT! If the crossed-out, wheeled-bin symbol is affixed to this machine, it signifies that this machine is compliant with the EU Directives as well as other similar end-of-life legislation in effect after August 13, 2005. Therefore, it must be collected separately after its use is completed and cannot be disposed as unsorted municipal waste.

The user is responsible for returning the machine to the appropriate collection facility, as specified by your local code.

For additional information regarding applicable local disposal laws, please contact the municipal waste facility and/or local authorized Taylor distributor.

Compressor Warranty Disclaimer

The refrigeration compressor(s) on this machine are warranted for the term stated in the Limited Warranty section in this manual. However, due to the Montreal Protocol and the U.S. Clean Air Act Amendments of 1990, many new refrigerants are being tested and developed, thus seeking their way into the service industry. Some of these new refrigerants are being advertised as drop-in replacements for numerous applications. It should be noted that in the event of ordinary service to this machine's refrigeration system, **only the refrigerant specified on the affixed data label should be used.** The unauthorized use of alternate refrigerants will void your Taylor compressor warranty. It is the machine owner's responsibility to make this fact known to any technician he/she employs.

It should also be noted that Taylor does not warrant the refrigerant used in its machine. For example, if the refrigerant is lost during the course of ordinary service to this machine, Taylor has no obligation to either supply or provide replacement refrigerant either at billable or unbillable terms. Taylor will recommend a suitable replacement if the original refrigerant is banned, obsolete, or no longer available during the five (5) year Taylor warranty of the compressor.

From time to time Taylor may test new refrigerant alternates. Should a new refrigerant alternate prove, through Taylor's testing, that it would be accepted as a drop-in replacement for this machine, then the disclaimer in this "Compressor Warranty Disclaimer" section will not apply to the use of the alternate refrigerant approved by Taylor.

To find out the current status of an alternate refrigerant as it relates to your compressor warranty, call Taylor or your local authorized Taylor distributor. Be prepared to provide the model/serial number of the machine in question.

We at Taylor Company are concerned about the safety of the operator when he or she comes in contact with the freezer and its parts. Taylor has taken extreme efforts to design and manufacture built-in safety features to protect both you and the service technician. As an example, warning labels have been attached to the machine to further point out safety precautions to the operator.



DANGER! Failure to adhere to the following safety precautions may result in severe personal injury or death. Failure to comply with these warnings may also damage the machine and/or its components. Such damage may require component replacement and service repair expenses.



NOTICE! DO NOT operate this machine without reading this entire manual first. Failure to follow all of these operating instructions may result in damage to the machine, poor performance, health hazards, or personal injury.



IMPORTANT! *This machine is to be used only by trained personnel. It is not intended for use, cleaning, or maintenance by children or people with reduced physical, sensory, or mental capabilities or lack of experience and knowledge, unless given supervision or instruction concerning the use of the machine by a person responsible for their safety. Children should be supervised to ensure that they do not play with the machine.*



IMPORTANT! *An equipotential grounding lug is provided with this machine. Some countries require the grounding lug to be properly attached to the rear of the frame by the authorized installer. The installation location is marked by the equipotential bonding symbol (5021 of IEC 60417-1) on both the removable panel and the machine's frame.*



WARNING! This machine must **NOT** be installed in an area where a water jet or hose can be used. **NEVER** use a water jet or hose to rinse or clean the machine. Failure to follow this instruction may result in electrocution.



WARNING! Avoid injury.

- **DO NOT** operate the machine unless it is properly grounded.
- **DO NOT** operate the machine with fuses larger than specified on the machine's data label.
- All repairs should be performed by an authorized Taylor service technician.
- The main power supplies to the machine must be disconnected prior to performing installation, repairs, or maintenance.
- **For Cord-Connected Machines:** Only Taylor service technicians or licensed electricians may install a plug or replacement cord on the machine.
- Machines that are permanently connected to fixed wiring and for which leakage currents may exceed 10 mA, particularly when disconnected or not used for long periods, or during initial installation, shall have protective devices to protect against the leakage of current, such as a GFI, installed by the authorized personnel to local codes.
- Stationary machines that are not equipped with a power cord and a plug or another device to disconnect the appliance from the power source must have an all-pole disconnecting device with a contact gap of at least 0.125 in. (3 mm) in the external installation.
- Supply cords used with this machine shall be oil-resistant, sheathed flexible cable not lighter than ordinary polychloroprene or other equivalent synthetic elastomer-sheathed cord (code designation 60245 IEC 57) installed with the proper cord anchorage to relieve conductors from strain, including twisting, at the terminals and protect the insulation of the conductors from abrasion.

SAFETY

- If the supply cord is damaged, it must be replaced by the manufacturer, service agent, or a similarly qualified person to avoid a hazard.
- Secure supply cord ground lead to machine in a location where if the cord is pulled the main power leads become taut before the ground lead can break loose.

Failure to follow these instructions may result in electrocution. Contact your local authorized Taylor distributor for service.



WARNING! Avoid injury.

- **DO NOT** allow untrained personnel to operate this machine.
- **DO NOT** operate the machine unless all service panels and access doors are fastened with screws.
- **DO NOT** remove any internal operating parts (including, but not limited to the freezer door, beater, or scraper blades) unless all control switches are in the OFF position.

Failure to follow these instructions may result in severe personal injury, especially to fingers or hands, from hazardous moving parts.



WARNING! This machine has many sharp edges that can cause severe injuries.

- **DO NOT** put objects or fingers in the door spout. This may contaminate the product and cause severe personal injury from blade contact.
- **USE EXTREME CAUTION** when removing the beater assembly. The scraper blades are very sharp.

Failure to follow these instructions can result in personal injury or damage to the machine.



WARNING! Only install this machine in a location where its use and maintenance is restricted to trained personnel. Failure to comply may result in personal injury.



CAUTION! This machine must be installed on a level surface to avoid the hazard of tipping. Extreme care should be taken in moving this equipment for any reason. Two or more persons are required to safely move this machine. Failure to comply may result in personal injury or machine damage.

Uncrate the machine and inspect it for damage. Report any damage to your Taylor distributor.

This machine is made in the USA and has USA sizes of hardware. All metric conversions are approximate and vary in size.



NOTICE! Cleaning and sanitizing schedules are governed by your federal, state, or local regulatory agencies and must be followed accordingly. Please refer to the cleaning section of this manual for the proper procedure to clean this machine.



CAUTION! This machine is equipped with a refrigerated cabinet designed to maintain product temperature at or below 41°F (5°C). Before replenishing the mix supply, the product must be refrigerated at or below 41°F (5°C). Failure to follow this instruction may result in health hazards and poor freezer performance.

DO NOT run the machine without product. Failure to follow this instruction can result in damage to the machine.

DO NOT obstruct air intake and discharge openings. A minimum of 3 in. (76 mm) air clearance on both sides of the machine is required. It is recommended to place the rear of the machine against the wall to prevent the recirculation of warm air. Failure to follow this instruction may cause poor freezer performance and damage to the machine.

For Indoor Use Only: This machine is designed to operate indoors, under normal ambient temperatures of 70°F to 75°F (21°C to 24°C). The machine has successfully performed in high ambient temperatures of up to 104°F (40°C) at reduced capacities.

Noise Level: Airborne noise emission does not exceed 78 dB(A) when measured at a distance of 39 in. (1.0 m) from the surface of the machine and at a height of 62 in. (1.6 m) from the floor.

Model 8752

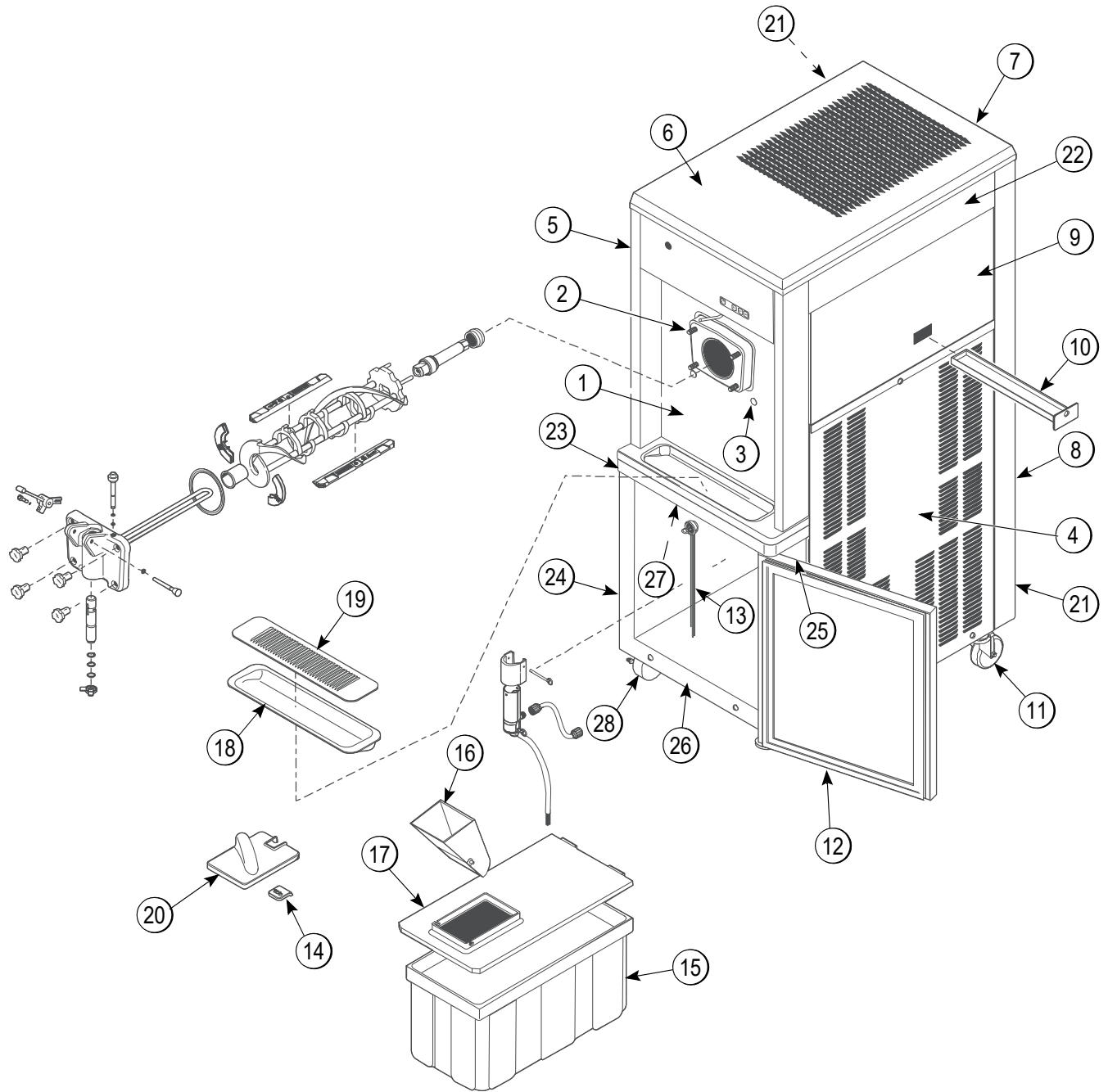

4

Figure 4-1

OPERATOR PARTS IDENTIFICATION

Model 8752 Parts Identification

Item	Description	Part No.
1	Panel A.-Front	X22997
2	Stud-Nose Cone	022822
3	Bolt-Carriage 1/4-20 x 3/4	012347
4	Panel A.-Lower Side	X23956SSP
5	Panel-Upper Side-L	028599
6	Hood	050464
7	Panel-Upper Rear	022074
8	Panel-Lower Rear	025128
9	Panel-Side-Upper-R	028600
10	Pan-Drip 11-5/8" Long	027503
11	Caster-3" SWV 3/4-10 Stem	021279
12	Gasket-Mix Door	020134
13	Probe A.-Mix-w/Handle	X35981
14	Boot-Mix Cover	037200

Item	Description	Part No.
15	Tank-Mix-15 Gallon	020275
16	Funnel-Mix	036637
17	Cover A.-Mix Tank-Single	X38726
18	Tray-Drip 16-7/8 x 5-1/8	020157
19	Shield-Splash	022765
20	Cover-Mix Storage	038827
21	Trim-Rear Corner	022071
22	Trim A.-Upper Side	X22423
23	Trim A.-Shelf	X20426
24	Trim-Front L.	024824-SP
25	Trim-Front R.	024825
26	Trim-Bottom Mix Door	024974
27	Trim-Mix Door	024976
28	Caster-3" SWV 3/4-10 Stem w/Brake	030307

4

Model 8752 Beater Door Assembly

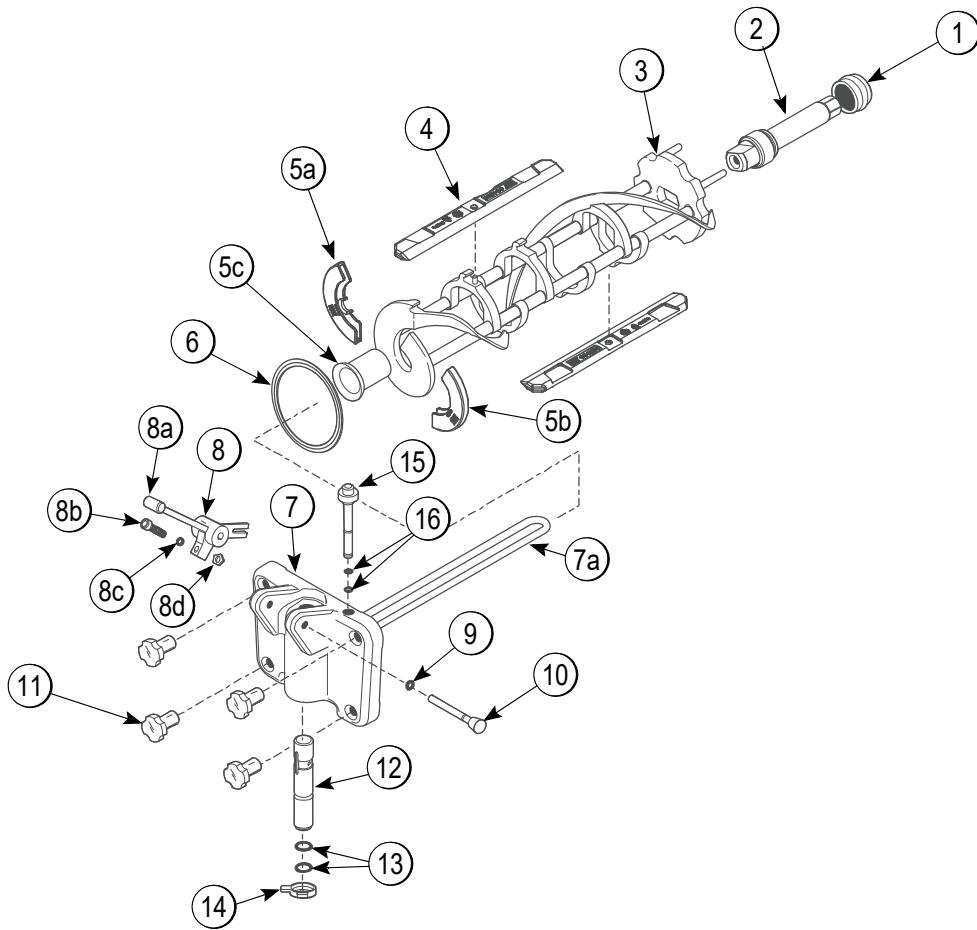

Figure 4-2

4

Item	Description	Part No.
1	Seal-Drive Shaft	032560
2	Shaft-Beater	032564
3	Beater A.-3.4QT-1 Pin	X46231
4	Blade-Scraper-Plastic	084350
5	Kit A.-Beater-Front Shoes-Bearing (5a-5c)	X50350
5a	Shoe-Front Helix-Front	050347
5b	Bearing-Front Shoe	050348
5c	Shoe-Front Helix-Rear	050346
6	Gasket-Door HT 4\"-Double	048926
7	Door A.-1 Spout	X51531-10
7a	Baffle A.-Log 4 in.	X50882
8	Handle A.-Draw-Adj. (8a-8d)	X55096
8a	Handle-Adjustable	28804

Item	Description	Part No.
8b	Screw-Adjustment	055092
8c	O-ring-1/4 OD x .070W 50 Duro (25 per bag)	015872
8d	Nut-Jam	029639-BLK
9	O-ring-5/16 OD x .070W (50 per bag)	016272
10	Pin A.-Pivot	X22820
11	Nut-Stud	021508
12	Valve A.-Draw	X18303
13	O-ring-7/8 OD x .103W (100 per bag)	014402
14	Cap-Design-1.010\" ID-6 Point	014218
15	Plug-Prime	028805
16	O-ring-3/8 OD x .070W (100 per bag)	016137

Model 8756

4

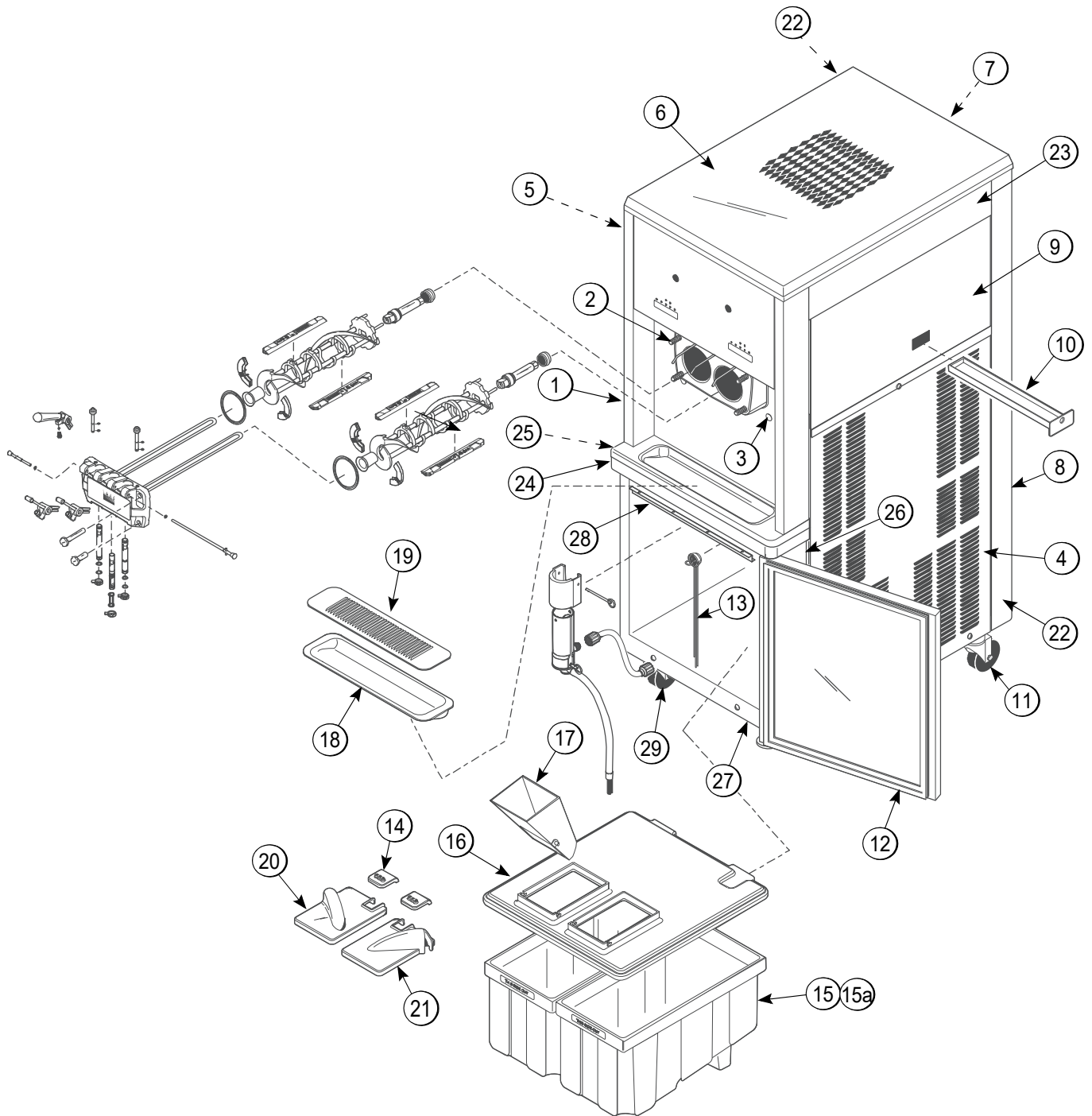

Figure 4-3

OPERATOR PARTS IDENTIFICATION

Item	Description	Part No.
1	Panel A.-Front	X22879
2	Stud-Nose Cone	022822
3	Bolt-Carriage 1/4-20x3/4	012347
4	Panel A.-Lower Side (Left/Right)	X23956-SER
5	Panel-Upper Side L.	028599
6	Hood	048526
7	Panel-Upper Rear	022015
8	Panel-Lower Rear	023598
9	Panel-Upper Side R.	028600
10	Pan-Drip 17-1/4" Long	027504
11	Caster-3" SWV 3/4-10 Stem	021279
12	Gasket-Cab Mix Door	024629
13	Probe A.-Mix-w/Handle	X35981
14	Boot-Cover-Mix	037200
15	Tank A.-Mix w/Decals	X38755-SER

Item	Description	Part No.
15a	Tank-Mix 9-Gallon	034928
16	Cover-Mix Tank	024590
17	Funnel-Mix	036637
18	Tray-Drip 22-7/8L x 5-18W	014533
19	Shield-Splash 23 L	022766
20	Cover-Left Mix Storage	037138
21	Cover-Right Mix Storage	037139
22	Trim-Corner (Left/Right)	022013
23	Trim A.-Side (Left/Right)	X22424
24	Trim A.-Shelf	X24813
25	Trim-Front L.	024824-SP
26	Trim-Front R.	024825
27	Trim-Bottom Cabinet	024826
28	Strip-Top Trim	024827
29	Caster-3" SWV w/Brake	030307

Model 8757

4

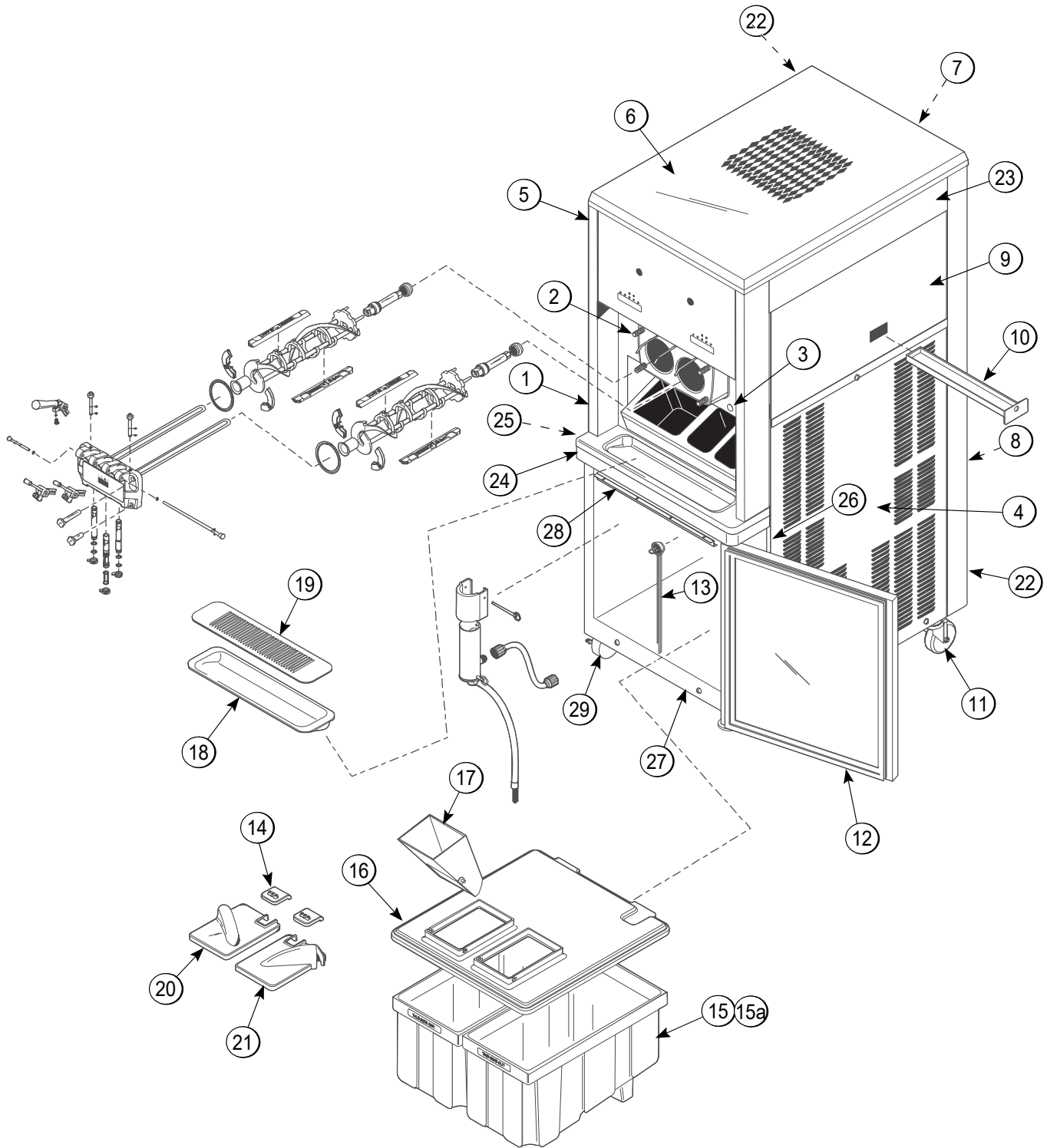

Figure 4-4

Item	Description	Part No.
1	Panel A.-Front	X69160-27
2	Stud-Nose Cone	068410
3	Bolt-Carriage 1/4-20 x 3/4	012347
4	Panel A.-Lower Side-L/R	X36741-SER
5	Panel-Upper Side Left	028599
6	Hood	048526
7	Panel-Upper Rear	042068
8	Panel-Lower Rear	042067
9	Panel-Upper Side Right	028600
10	Pan-Drip	036232
11	Caster-Swivel 3/4-10 ST	021279
12	Gasket-Cabinet-Mix Door	024629
13	Probe A.-Mix-w/Handle	X35981
14	Boot-Mix Cover	037200
15	Tank-Mix	X38755-SER
15a	Tank (Only)	034928

Item	Description	Part No.
16	Cover-Mix Tank	024590
17	Funnel-Mix	036637
18	Tray-Drip	014533
19	Shield-Splash 23" Long	022766
20	Cover-Mix Storage Left	037138
21	Cover-Mix Storage Right	037139
22	Trim-Rear Corner-Left/Right	036740
23	Trim A. Side Left/Right	X22424
24	Trim A.-Shelf	X36732
25	Trim-Front-Left	024824-SP
26	Trim-Front-Right	024825
27	Trim-Bottom Cabinet	024826
28	Strip-Top Trim	024827
29	Caster-3" SWV 3/4-10 Stem w/Brake	030307

8756 and 8757 Beater Door Assembly

4

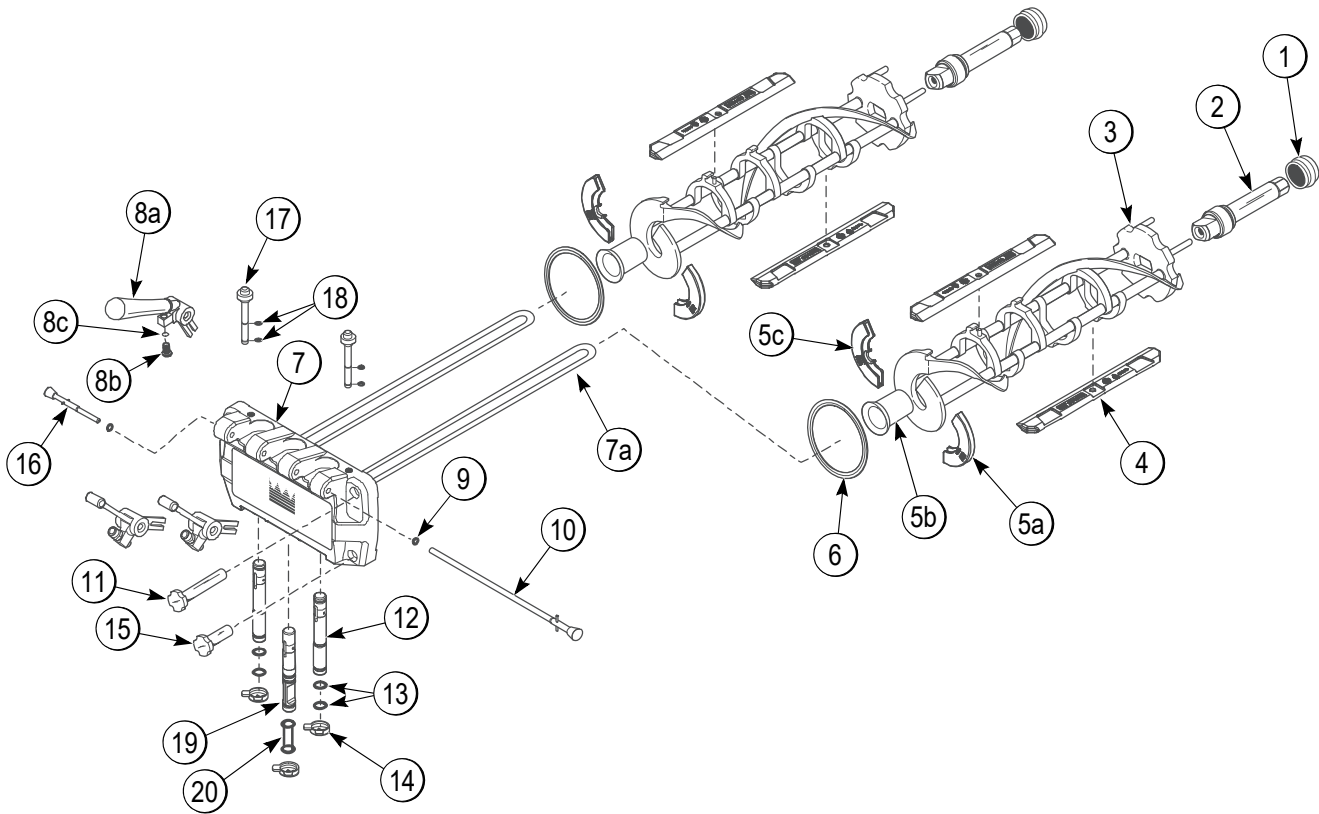
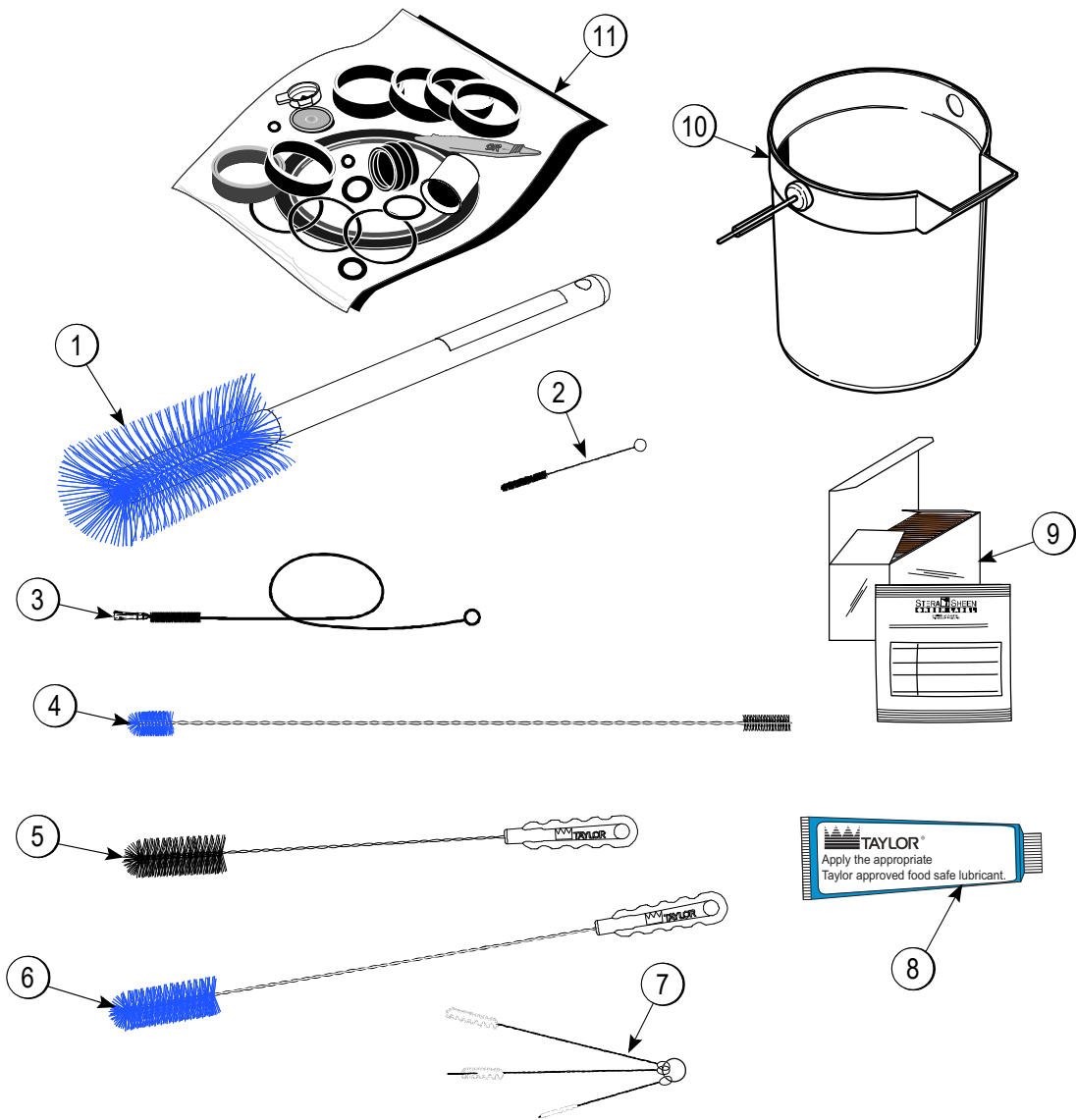

Figure 4-5

Item	Description	Part No.
1	Seal-Drive Shaft	032560
2	Shaft-Beater	032564
3	Beater A.-3.4 qt.-1 Pin	X46231
4	Blade-Scraper-Plastic	084350
5	Kit A.-Beater-Front Shoes-Brng (5a-5c)	X50350
5a	Shoe-Front Helix-Front	050347
5b	Bearing-Front Shoe	050348
5c	Shoe-Front Helix-Rear	050346
6	Gasket-Door HT 4\"-Double	048926
7	Door A.-3 Spout	X51532-12
7a	Baffle A.-Long 4 in. w/Rad	X50882
8	Handle A.-Draw (8a-8c)	X81010-SP
8a	Handle A.-Adj Theaded	X80889-SP
8b	Screw-Adjustment-5/16-24	056332

Item	Description	Part No.
8c	O-ring-1/4 OD x .070W	015872
9	O-ring-5/16 OD x .070W	016272
10	Rod A.-Pivot-Long	X22387
11	Nut-Stud-Long	034382
12	Valve A.-Draw	X69539
13	O-ring-7/8 OD x .103W	014402
14	Cap-Design-1.010\" ID-6-Point	014218
15	Nut-Stud-Short	034383
16	Rod A.-Pivot-Short	X22388
17	Plug-Prime	028805
18	O-ring-3/8 OD x .070W	016137
19	Valve A.-Draw-Center	X84411
20	Seal-Draw Valve * Large H-Ring*	034698

Accessories



4

Figure 4-6

Item	Description	Part No.
1	Brush-Mix Pump Body-3 x 7	023316
2	Brush-Pressure Switch-1/8"	027647
3	Brush-Feed Tube 9/16 x 44	021101
4	Brush-Double Ended	013072
5	Brush-Rear Bearing 1 x 2 x 14	013071
6	Brush-Draw Valve 1 x 2 x 17	013073
7	Brush Set-LVB	050103
8	Lubricant-Taylor 4 oz.	047518

Item	Description	Part No.
9*	Sanitizer-Stera Sheen	See Note
10	Pail-10 qt.	013163
11	Kit A.-Tune Up-1 Spout (8752)	X49463-15
	Kit A.-Tune Up-3 Spout (8756 and 8757)	X49463-2
12	Kit A.-Mix Level Probe Socket	X35813

**Note: A sample of sanitizer is shipped with a new machine. Order additional sanitizer, using one of the part numbers listed.*

Model 8752

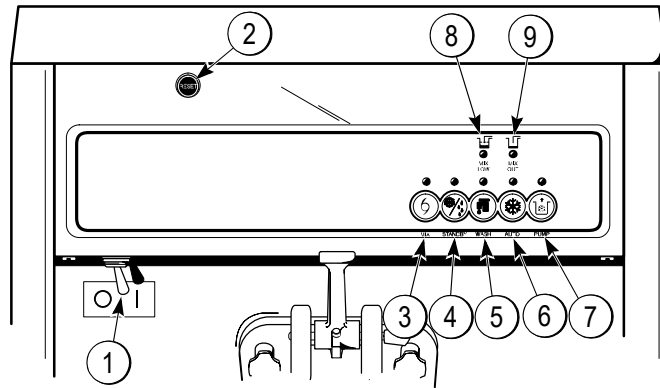

Model 8756

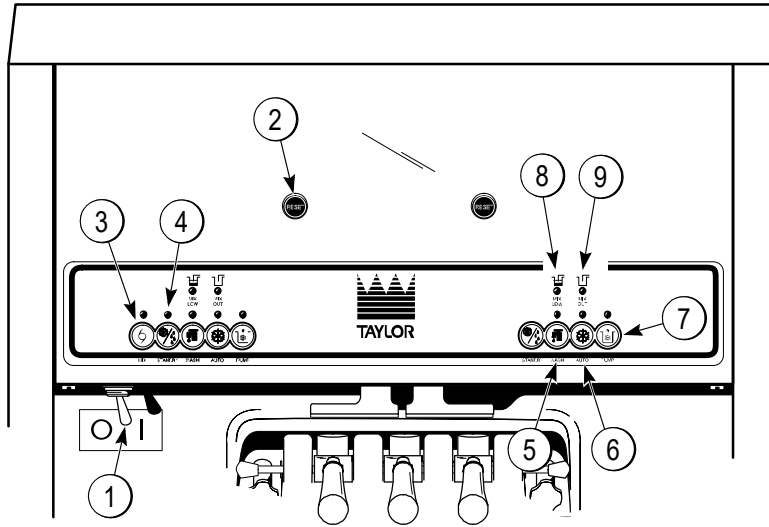

Model 8757

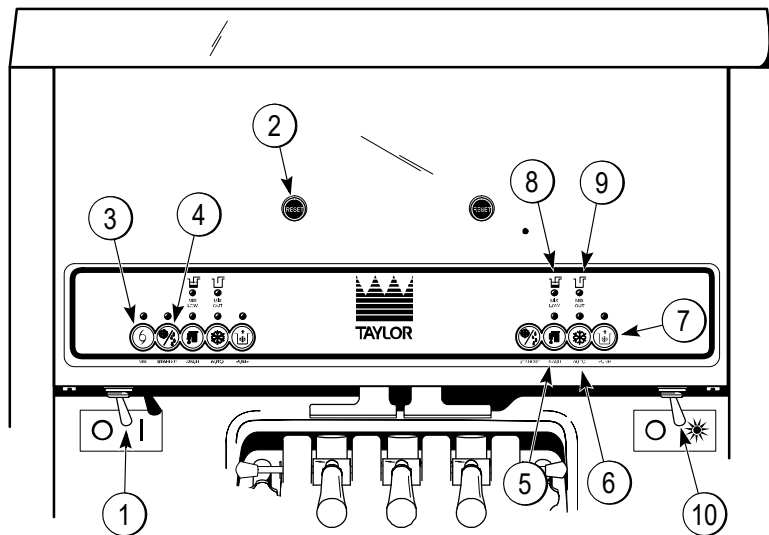

Figure 5-1

Item	Description
1	Power Switch (Toggle)
2	RESET Switch
3	Mix Refrigeration Control
4	STANDBY Button
5	WASH Button
6	AUTO Button
7	PUMP Button
8	MIX LOW Indicator
9	MIX OUT Indicator
10	Heater Switch

Symbol Definitions

To better communicate in the international arena, the words on many of our operator switches and buttons have symbols to indicate their functions. Your Taylor machine is designed with these international symbols.

5

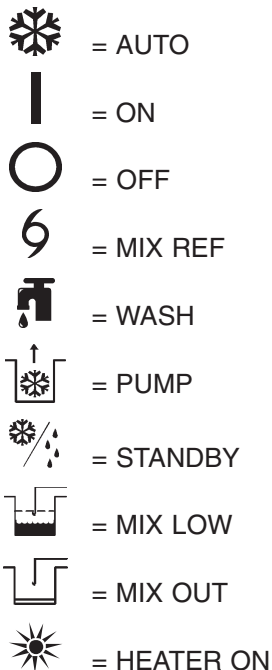

Figure 5-2

Power Switch

When placed in the ON position, the power switch allows Softech™ control panel operation.

RESET Button

The RESET button is located in the decorative plate above the Softech™ controls. The reset protects the beater motor from an overload condition. If an overload occurs, the reset mechanism will trip. To properly reset the machine, press the AUTO button to cancel the cycle. Turn the power switch to the OFF position. Press the RESET button firmly. Turn the power switch to the ON position.

Press the WASH button and observe the machine's performance. Open the side access panel to check if the beater motor is turning the driveshaft in a clockwise (from operator end) direction without binding.

If it is turning properly, press the WASH button to cancel the cycle. Press the AUTO button to resume normal operation. (On models 8756 and 8757, press the AUTO button on both sides to resume normal operation.) If the machine shuts down again, contact a service technician.

Indicator Lights

MIX LOW

When the MIX LOW light begins to flash, the mix tank has a low supply of mix and should be refilled as soon as possible.

MIX OUT

When the MIX OUT light begins to flash, the mix tank has an insufficient supply of mix to operate the machine. At this time, the standby and Auto mode is locked out and the machine shuts down. To initiate the refrigeration system, add mix to the tank and press the AUTO button. The machine will automatically begin operation.

Softech™ Control Operation

MIX REF

When the MIX REF button is pressed, the mode indicator lights indicate that the mix cabinet refrigeration system is operating. (On Models 8756 and 8757, there are two touch-tone panels, one for each freezing cylinder. The mix refrigeration system is controlled by the MIX REF button found on the left panel. If the AUTO button is pressed on either side of the machine, the MIX REF function is automatically activated.) The MIX REF function cannot be canceled unless the Auto or Standby mode is canceled first.

WASH

When the Wash button is pressed, the indicator lights illuminate to indicate that the beater motor is operating. The Standby or Auto modes must be canceled first to activate the Wash mode.

AUTO

When the AUTO button is pressed, the indicator lights illuminate to indicate that the main refrigeration system has been activated. In the Auto mode, the Wash or Standby functions is automatically canceled. The Mix Ref function is automatically locked in to maintain the mix in the cabinet, and the Pump function is locked in to allow air/mix pump operation as required.

Pump

When the PUMP button is pressed, the indicator lights indicate that the air/mix pump will operate as required.

Note: An indicating light and an audible tone will sound whenever a mode of operation has been pressed. To cancel any function, press the PUMP button again and the light and mode of operation will shut off.

Standby

(US and Canada Only)

During long no-sale periods it becomes necessary to warm product in the freezing cylinder to approximately 35°F to 40°F (1.7°C to 4.4°C) to prevent overbeating and product breakdown.

When the STANDBY button is pressed, the light comes on, indicating the cylinder temperature retention system (CTR) has been activated. In the Standby mode, the Wash, Pump, and Auto functions are automatically canceled. The Mix Ref function is automatically locked in to maintain the mix in the cabinet.

To resume normal operation, press the AUTO button. When the machine cycles off, product in the freezing cylinder will be at serving viscosity.

Note: A mode indicator will light and an audible tone will sound whenever a mode of operation button has been pressed. To cancel any function, press the button again and the light and mode of operation will shut off.

Adjustable Draw Handle

These machines feature an adjustable draw handle to provide the best portion control, giving a better, consistent quality to your product and controlling costs. The draw handle should be adjusted to provide a flow rate of 5 oz. to 7-1/2 oz. (142 g to 213 g) of product by weight per 10 seconds. To increase the flow rate, turn the screw counterclockwise. To decrease the flow rate, turn the screw clockwise.

In addition, for purposes of sanitizing and rinsing, the flow rate can be increased by removing the pivot pin and placing the restrictive bar on the top. When drawing product, always have the restrictive bar on the bottom.

Important! When dispensing product, pull only one draw handle at a time.

Most of the illustrated step-by-step operating procedures contained in this manual are of the 8752. The 8752, 8756, and 8757, for all practical purposes of operation, are the same.

Model 8752 has one freezing cylinder, and Models 8756 and 8757 have two freezing cylinders. The size of each freezing cylinder is 3.4 qt. (3.2 L). Mix is stored in the lower front refrigerated compartment and is pumped up to the freezing cylinder by an air/mix pump.

Duplicate the following procedures, where they apply, for the second freezing cylinder on Models 8756 and 8757.

We begin our instructions at the point where we enter the store in the morning and find the parts laid out to air-dry from the previous night's brush-cleaning.

If you are disassembling the machine for the first time or need information to get to this starting point in our instructions, turn to "Disassembly" on page 6-14, and start there.

Prior to Setup (Model 8757)

1. Remove the two stainless-steel syrup jars with topping pumps from the syrup rail. Check the water level in the heated syrup topping well. Make sure the water is filled to the indicating mark on the bottom of the well. (The heated rail should have 32 oz. [946.2 ml] of water.)
2. Place the heater switch in the ON position.

Note: This heating process will take approximately 2.5 hours to reach temperature. The water level in the topping wells must be checked at least once daily.
3. Prepare a pail of an approved 100 ppm sanitizing solution (examples: Stera-Sheen® or Kay-5®). Use warm water according to the manufacturer's specifications. Sanitize the topping pumps by placing the entire pump assembly in the pail of sanitizing solution. Pump the solution through to thoroughly sanitize the pump.
4. Fill the two heated and the two cold syrup jars with topping. Replace the topping pumps in the heated syrup jars. Sanitize two topping ladles and place them in the cold syrup jars.

Assembly



WARNING! Make sure the control switch is in the Off position to eliminate the chance of moving parts. Failure to follow this instruction may result in severe personal injury from hazardous moving parts.

1. Lubricate the groove and shaft portion that comes in contact with the bearing on the beater driveshaft. Slide the seal over the shaft and groove until it snaps into place. **Do Not** lubricate the hex end of the driveshaft. Fill the inside portion of the seal with 1/4 in. (6.3 mm) more lubricant and evenly lubricate the end of the seal that fits onto the rear-shell bearing.

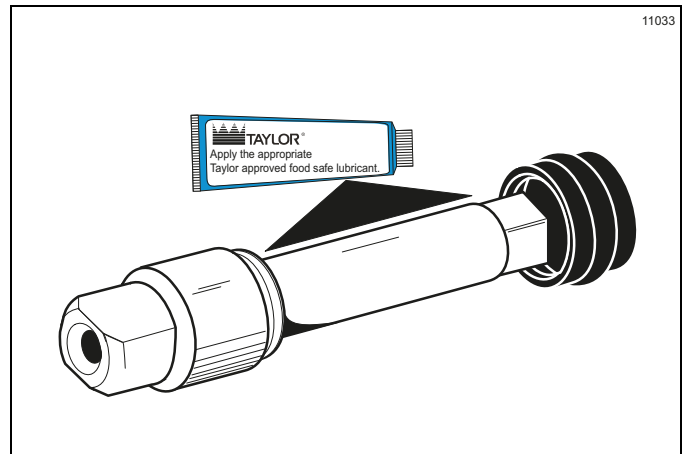

Figure 6-1

Note: For ease of cleaning, the seal may be turned inside out. Make sure to position the seal correctly during assembly.



Figure 6-2

OPERATING PROCEDURES

2. Install the driveshaft through the rear-shell bearing in the freezing cylinder and engage the hex end firmly into the gearbox coupling. Make sure the driveshaft fits into the drive coupling without binding.

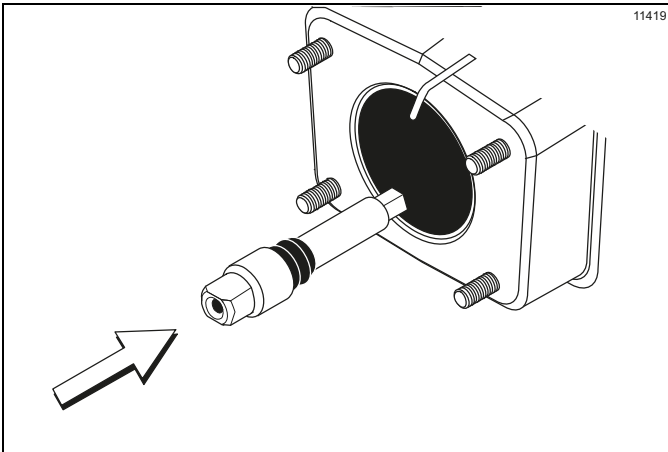

Figure 6-3



WARNING! Use extreme caution when handling the beater assembly. The scraper blades are very sharp and may cause injury.

3. Before installing the beater assembly, check the scraper blades for any signs of wear or damage. If a scraper blade is nicked or worn, replace both blades.

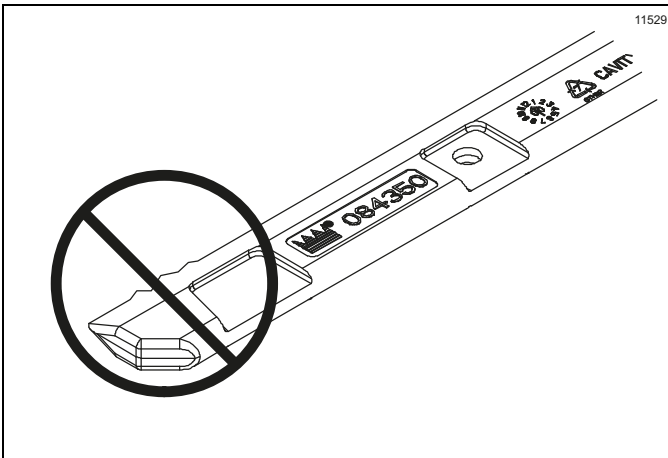

Figure 6-4

4. If the blades and clips are in good condition, place the rear scraper blade over the rear holding pin on the beater.

Note: The hole on the scraper blade must fit securely over the pin to prevent costly damage.

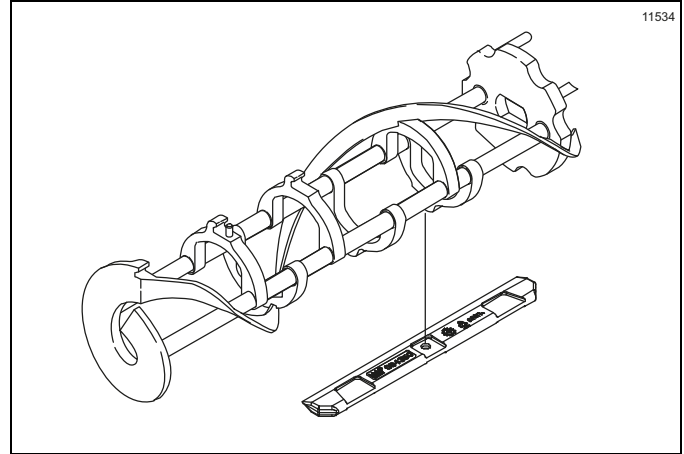

Figure 6-5

Note: Replace scraper blades every 3 months.

5. Holding the rear blade on the beater, slide it into the freezing cylinder halfway. Install the front scraper blade over the front holding pin.

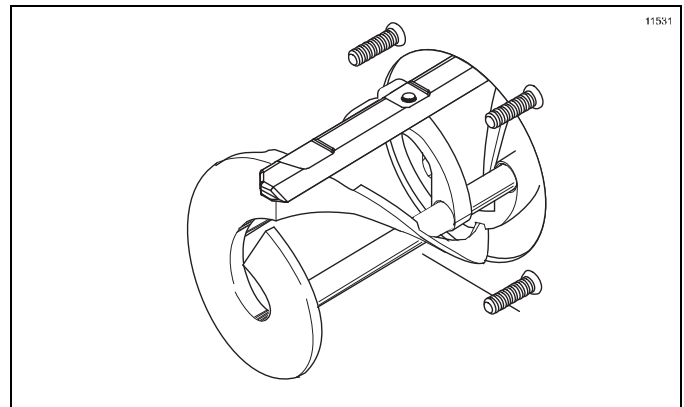

Figure 6-6

6. Before installing the beater shoes, check the shoes for any nicks, cracks, or signs of wear. If any defects are present, replace the beater shoes.
7. Install the beater shoes.

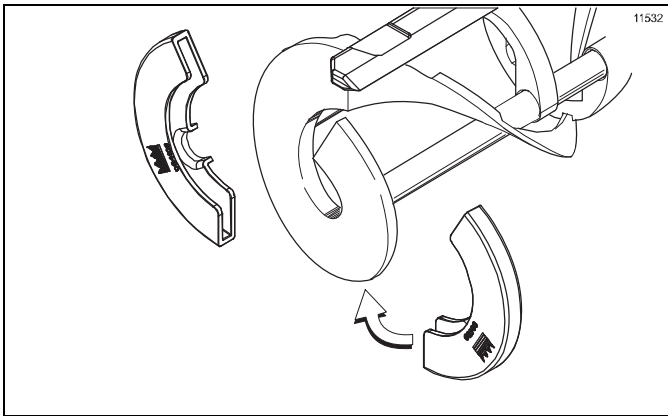

Figure 6-7

8. Slide the beater assembly the rest of the way into the freezing cylinder.

Make sure the beater assembly is in position over the driveshaft. Turn the beater slightly to make sure that the beater is properly seated. When in position, the beater **will not** protrude beyond the front of the freezing cylinder.

9. **Repeat step 1 through step 7** for the other side of the machine on Models 8756 and 8757.
10. Before assembling the freezer door, check the following for any nicks, cracks, or signs of wear: door bearing, door gasket, draw valve, O-rings, and all sides of the door assembly, including the inside of the draw valve bore. Replace any damaged parts.
11. Place the large rubber gasket(s) in the groove(s) on the back side of the freezer door.

Slide the white plastic front bearing(s) over the baffle rod(s), making sure that the flanged end of the bearing is resting against the freezer door. **Do Not** lubricate the gasket(s) or front bearing(s).

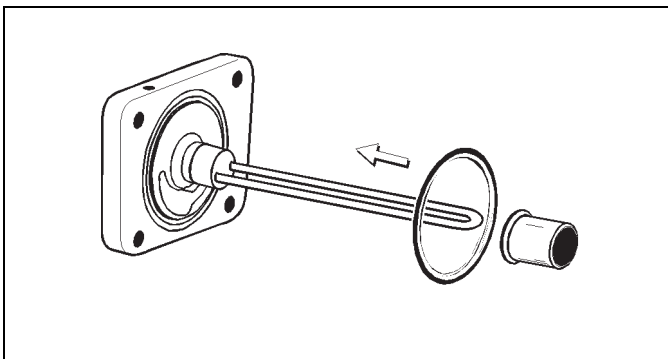

Figure 6-8

Note: There are two gaskets and two front bearings for the Models 8756 and 8757 door, one for each freezing cylinder.

12. Slide the O-rings into the grooves on the prime plug(s). Apply an even coat of lubricant to the O-rings and shaft(s).

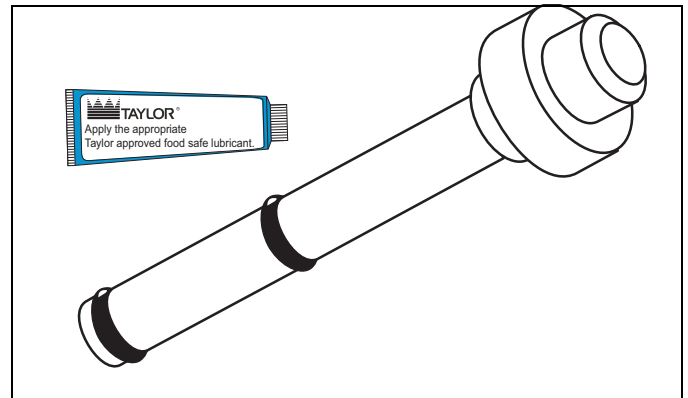

Figure 6-9

Note: There are two prime plugs for models 8756 and 8757 door, one for each freezing cylinder.

13. Insert the prime plug(s) into the hole(s) at the top of the freezer door and push down.

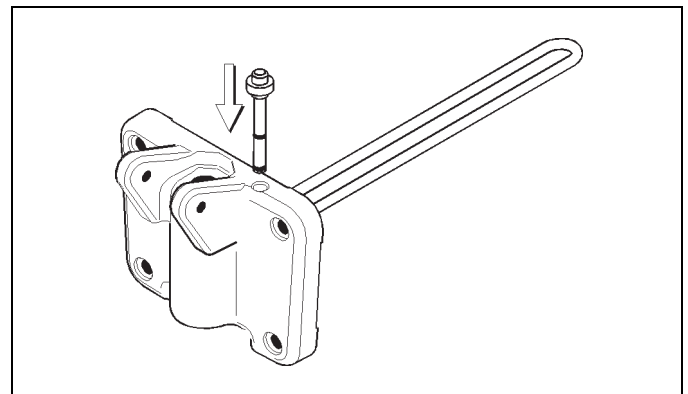

Figure 6-10

OPERATING PROCEDURES

14. Insert the baffle rod(s) through the beater(s) in the freezing cylinder(s). With the door seated on the freezer studs, install the handscrews. Tighten equally in a crisscross pattern to ensure the door is snug.

Note: On Models 8756 and 8757, the short handscrews go on the bottom and the long handscrews go on the top.

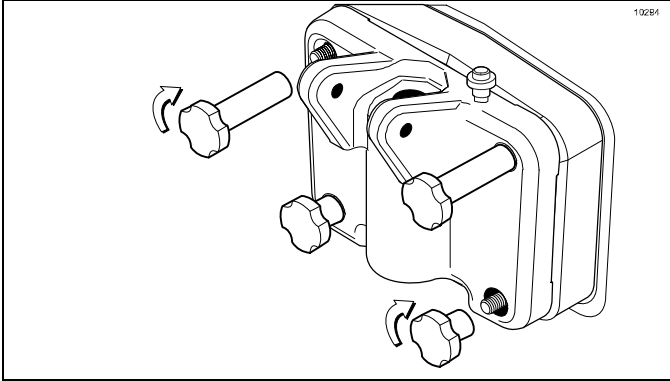

Figure 6-11

15. Install the draw valve(s). Slide the two O-rings into the grooves on the draw valve(s) and lubricate.

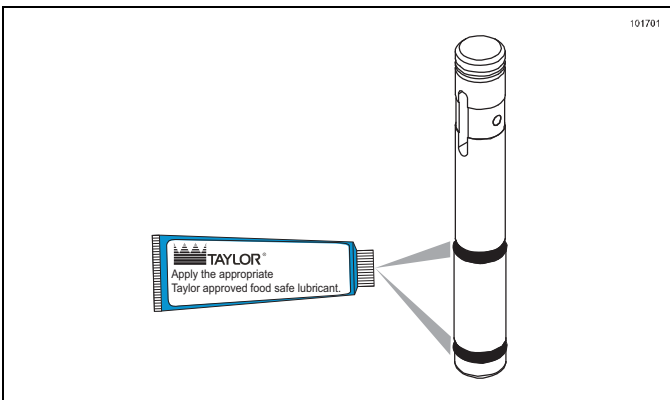

Figure 6-12

Note: Models 8756 and 8757 have three draw valves.

16. Lubricate the inside of the freezer door spout(s), top and bottom, and insert the draw valve(s) from the bottom until the slot in the draw valve(s) comes into view.

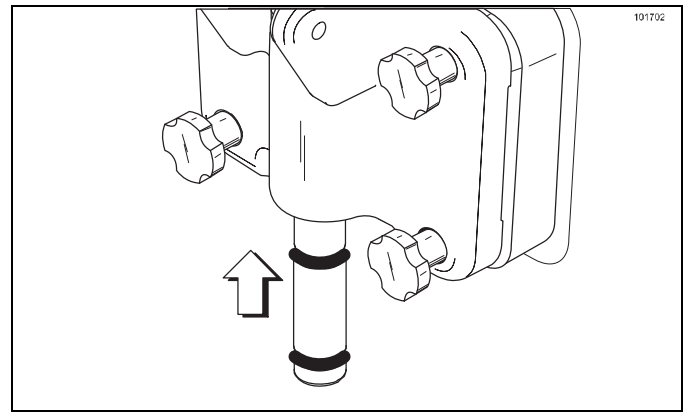

Figure 6-13

17. Install the adjustable draw handle(s). Slide the O-ring(s) into the groove(s) on the pivot pin(s) and lubricate.

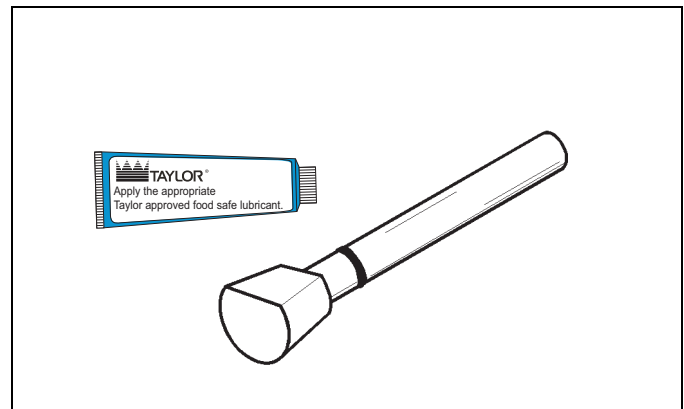

Figure 6-14

18. Slide the fork of the draw handle(s) in the slot of the draw valve(s). Secure with pivot pin.

Note: Models 8756 and 8757 have three draw handles and two pivot pins. Slide the fork of the draw handle in the slot of the draw valve, starting from the right. Slide the long pivot pin through the right and middle draw handles. Secure the left draw handle with the short pivot pin.

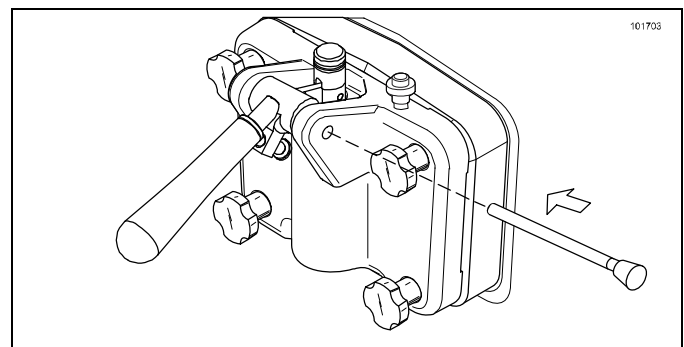

Figure 6-15

Note: These machines feature adjustable draw handles to provide the best portion control, giving a better consistency quality to your product and controlling costs. The draw handles can be adjusted for different flow rates. See page 5-3 for more information on adjusting these handles.

19. Snap the design cap over the bottom of each door spout.

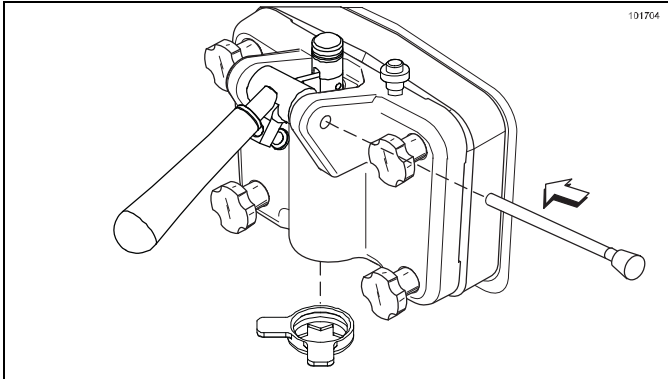

Figure 6-16

20. Install the rear drip pan. Slide the rear drip pan into the hole in the side panel.

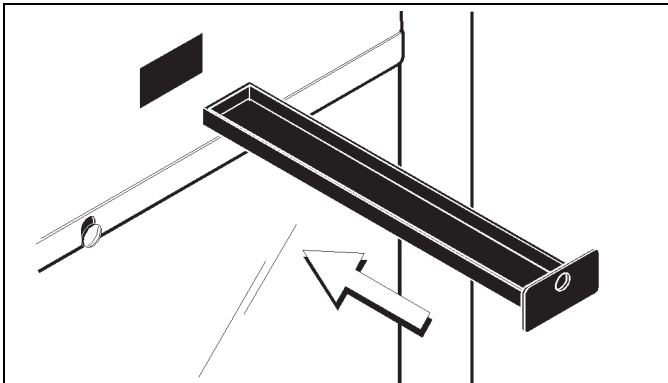

Figure 6-17

21. Install the front drip tray and the splash shield beneath the door spout(s).

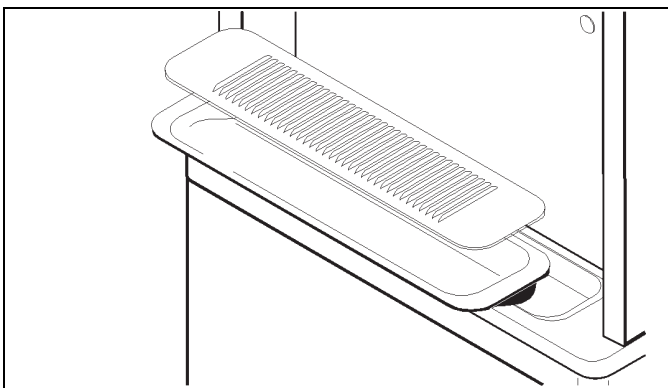

Figure 6-18

Air/Mix Pump Assembly

The purpose of the air/mix pump is to meter a specific amount of air and mix and transfer this combination to the freezing cylinder.

Refer to the illustration on page 6-9 for identification of parts during assembly.

1. Inspect the rubber and plastic pump parts. The O-rings, check ring, and gasket must be in 100% good condition for the pump and entire machine to operate properly. They cannot properly serve their intended function if nicks, cuts, or holes in the material are present.
Inspect the plastic pump parts for cracks, wear, and delamination of plastic.
Replace any defective parts immediately and discard the old.
2. Assemble the piston. Slide the O-ring into the groove on the piston. **Do Not** lubricate this O-ring.

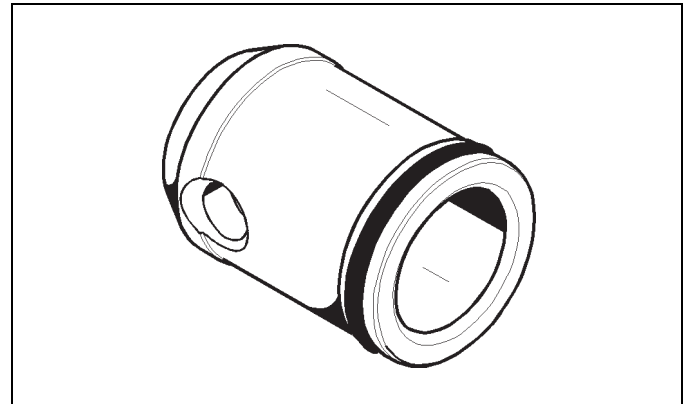

Figure 6-19

3. Assemble the liquid valve body. Slide the three check bands and three O-rings into the grooves on the liquid valve body. **Do Not** lubricate the check bands or O-rings.

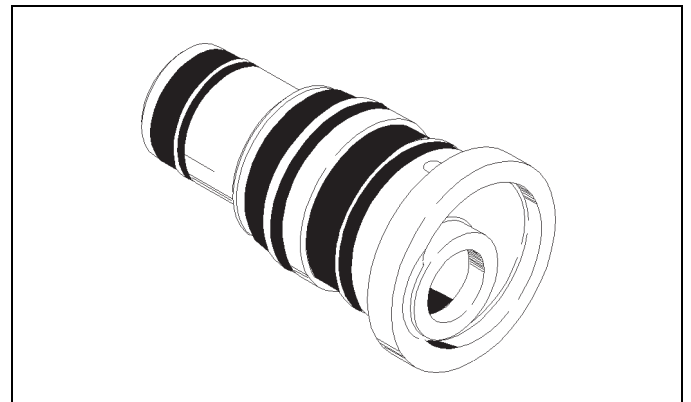

Figure 6-20

OPERATING PROCEDURES

Note: Check bands have two smooth surfaces. A concave shape indicates an incorrect assembly. Turn the check band inside out to correctly expose the flat surface.

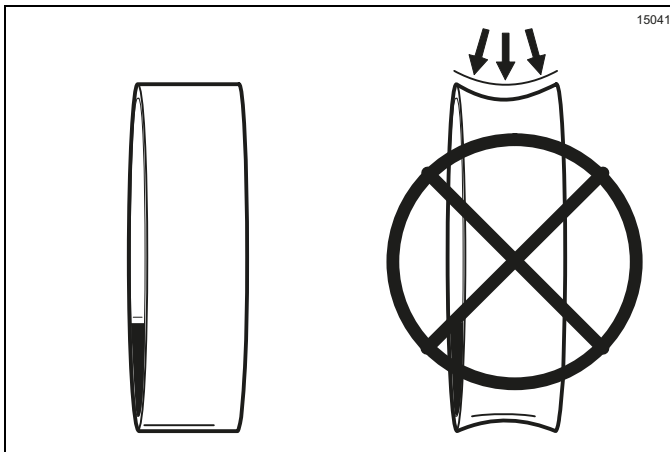

Figure 6-21

- Put a small amount of lubricant inside the piston and insert the liquid valve body into the piston.
- Apply a small amount of lubricant to the lower inside diameter of the pump cylinder to a depth equivalent to the length of your index finger. Once applied, the amount of lubricant should be equal to a paper-thin film.

6

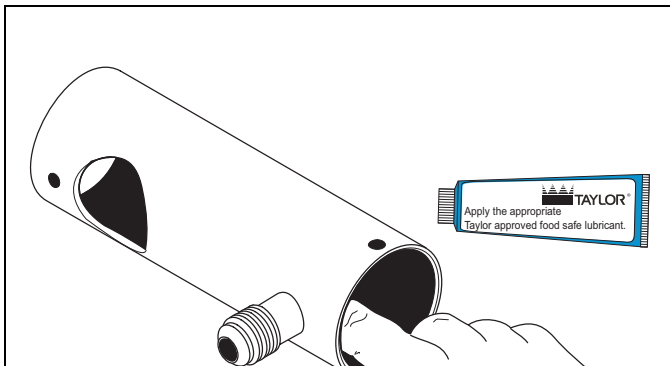

Figure 6-22

- Insert the assembled piston and liquid valve body into the pump cylinder and push upward. Align the steel button at the base of the liquid valve body with the cut-out groove at the bottom of the pump cylinder.

Note: The drive hole in the piston must be visible through the drive hole in the pump cylinder.

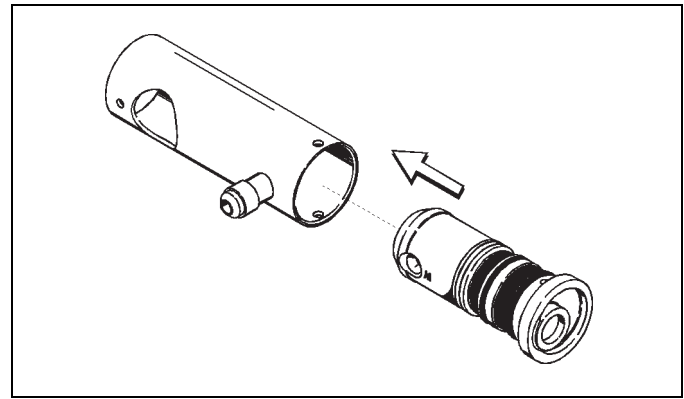

Figure 6-23

- Assemble the mix inlet fitting. Slide the O-ring into the groove on the mix inlet fitting and lubricate with Taylor Lube.

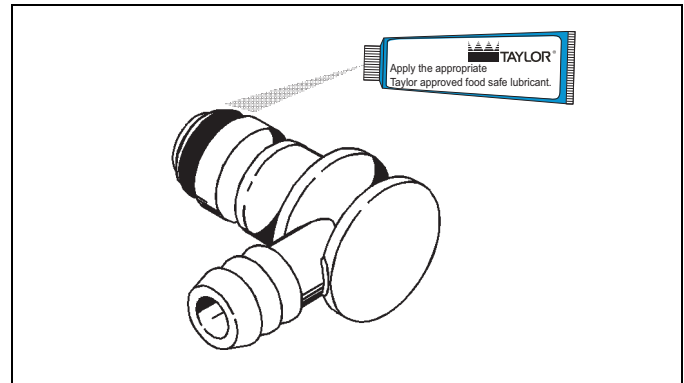

Figure 6-24

- Attach the spring and poppet to the end of the mix inlet fitting above the O-ring. The spring must be securely fastened and not allowed to float freely.

Note: The rubber poppet and spring act as a pressure relief valve to prevent a pressure build-up in the freezing cylinder.

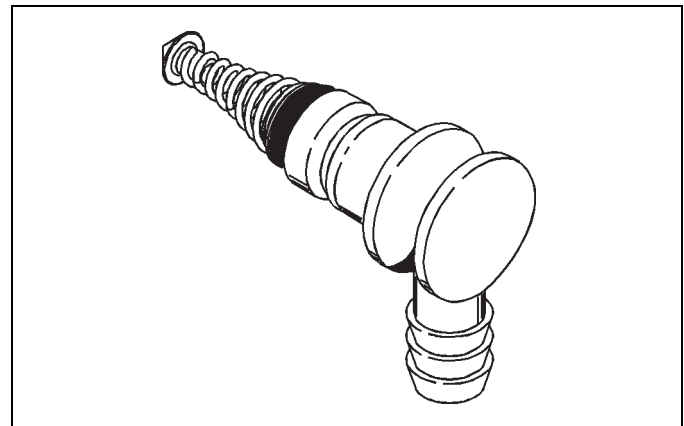

Figure 6-25

9. Insert the mix inlet fitting into the hole in the base of the liquid valve body.

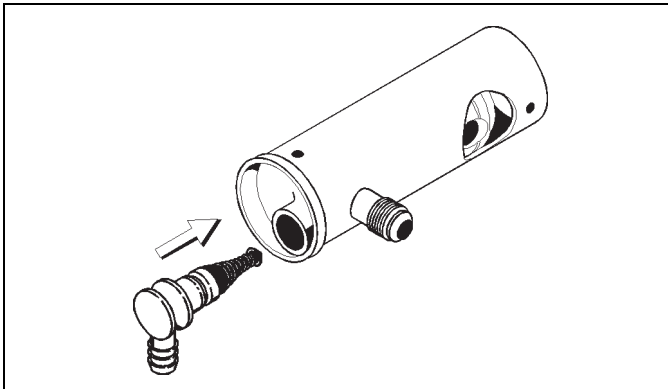

Figure 6-26

10. Secure the pump parts in position by sliding the retaining pin through the crossholes located at the bottom of the pump cylinder.

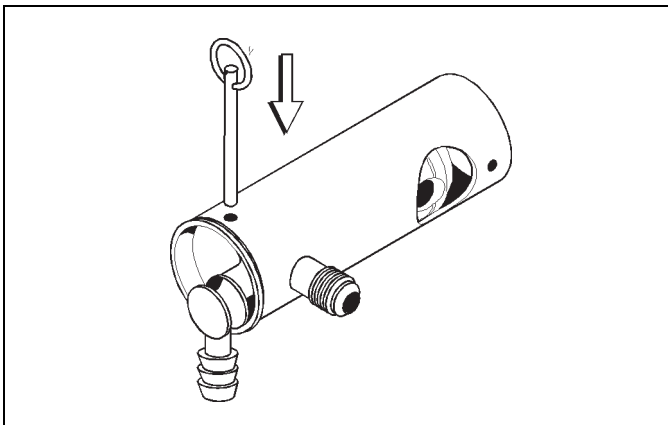

Figure 6-27

Note: The suction line must fit tightly against the mix inlet fitting

11. Assemble the flare line and suction line. Assemble the weighted end into the suction line. Attach the mix suction line to the barbed end of the mix inlet fitting and allow the weighted end to hang free.

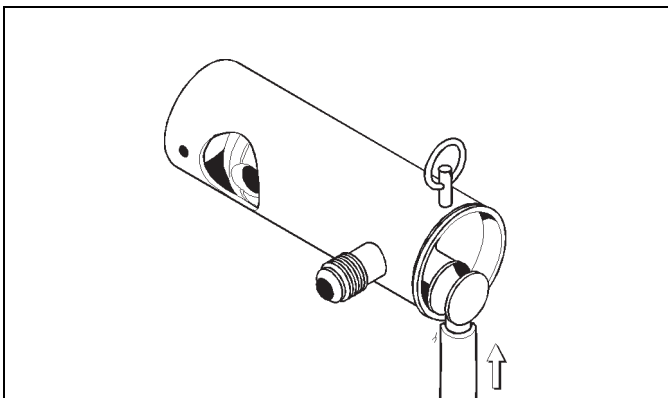

Figure 6-28

12. Push both nuts back from the flare end and lightly lubricate the underside of the plastic flare. This will allow the nut to turn freely without twisting the tubing.
13. Attach one end of the flare line to the threaded fitting on the lower side of the pump cylinder and allow the other end to hang free.

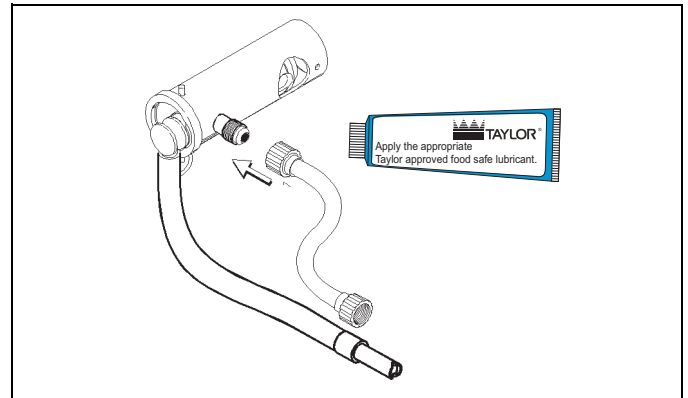

Figure 6-29

14. Secure the air/mix pump. Place the pump collar over the pump cylinder. (The crossholes of the pump collar should be on top.)

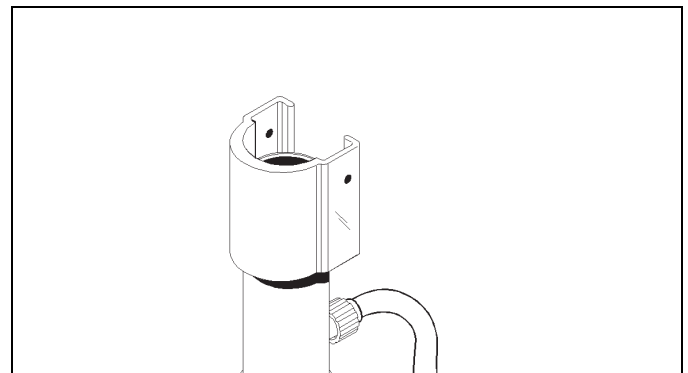

Figure 6-30

15. Align the drive hole in the piston to the ball crank of the motor reducer. At the same time, align the locating pin hole in the pump cylinder to the locating pin on the face plate.

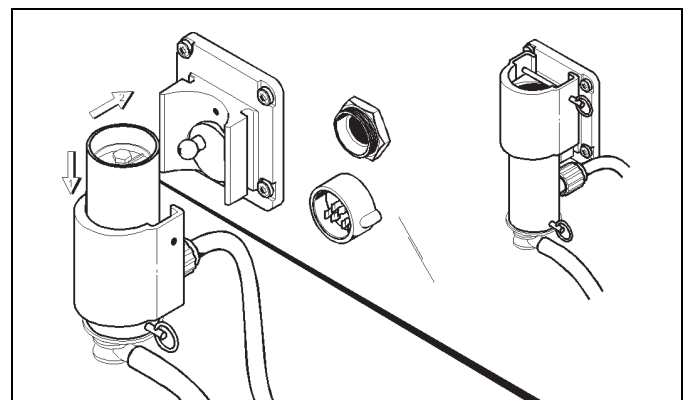

Figure 6-31

OPERATING PROCEDURES

16. Slide the pump collar upwards into the grooves on the side of the face plate and secure the air/mix pump in place by slipping the retaining pin through the crossholes of the pump collar.

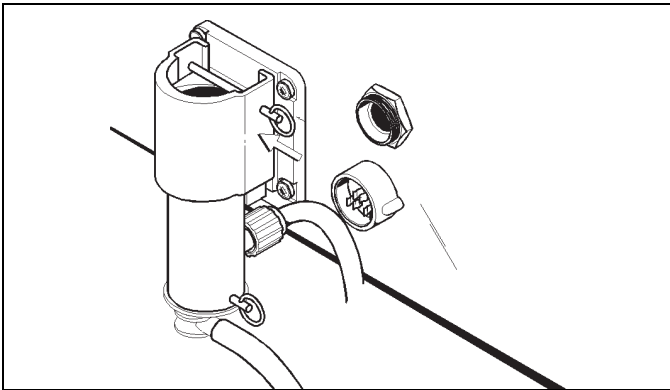

Figure 6-32

Note: Alignment of the air/mix pump is extremely important. Severe and costly damage may occur if it is not properly aligned.

17. Lubricate both sides of the pressure switch diaphragm.

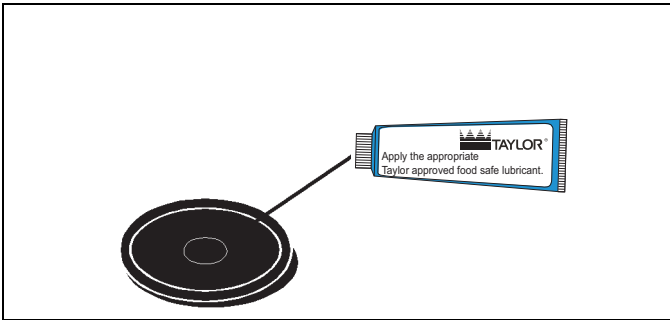

Figure 6-33

18. Place the diaphragm on the front face of the pressure switch housing. The lubricant will act as an adhesive to hold the diaphragm in place.

Note: **Do Not** place the diaphragm in the pressure switch cap.

19. Screw the cap onto the housing securely.

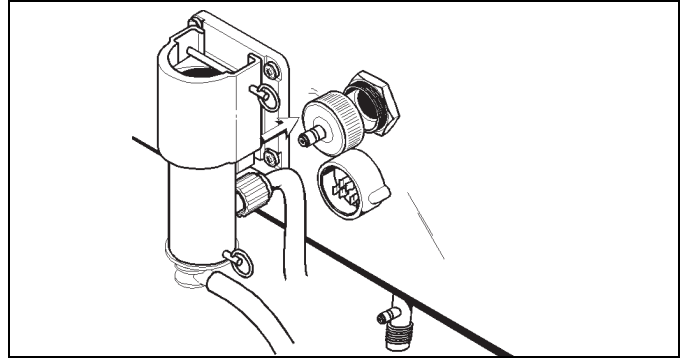

Figure 6-34

20. Repeat Steps 1 through 8 for the other side of the machine on Models 8756 and 8757.

Air/Mix Pump Assembly Exploded View

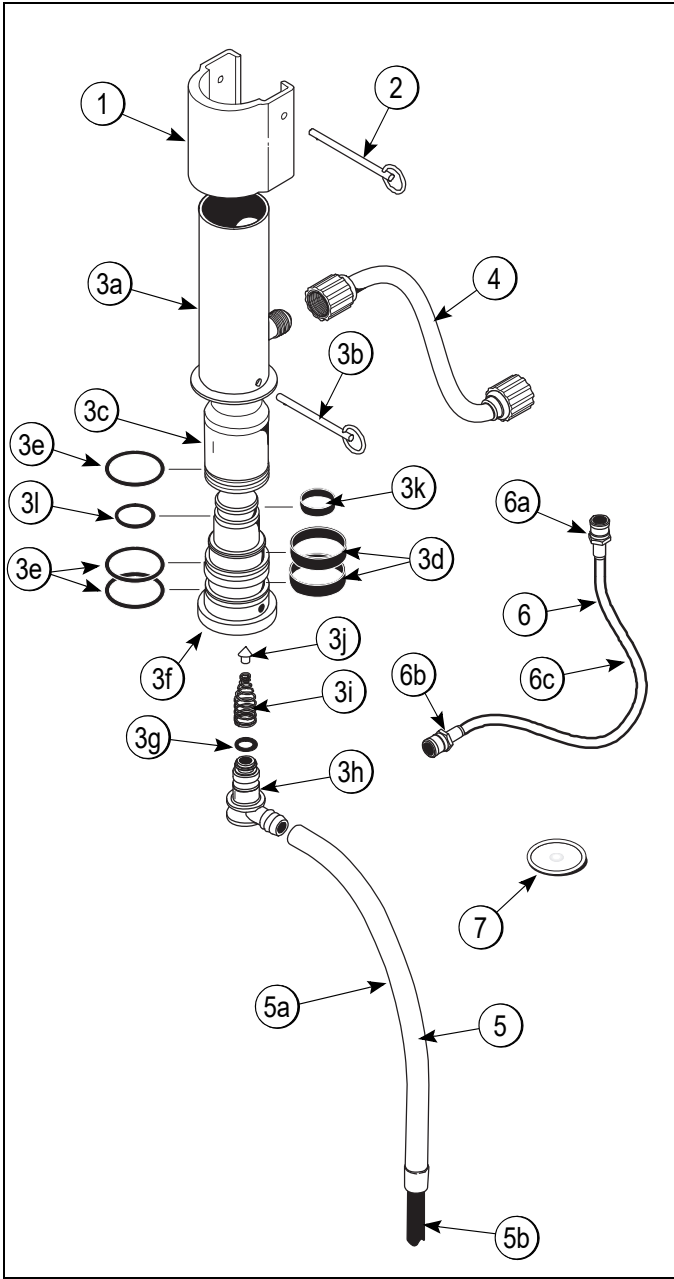

Figure 6-35

Item	Description	Part No.
1	Cap-Pump (8752)	023324
	Cap-Pump (8756 and 8757)	021276-9
2	Pin-Retaining	021276-8
3	Pump A.-Soft Serve (Includes 3a- 3l)	X36201
3a	Cylinder-Pump	022345-1
3b	Pin-Retaining	021276-8
3c	Piston	032733
3d	Ring-Check 2 in. OD x 1/2	020050
3e	O-ring-2-1/8 OD x .139W (50 Per Bag)	020051
3f	Body A.-Valve	X36202
3g	O-ring-13/6 OD x .139W (50 Per Bag)	21278
3h	Elbow-Inlet 90 Deg	022502-4
3i	Spring-Tapered 1-7/8L	022456
3j	Poppet-Rubber-Black	022473
3k	Ring-Check 1-1/4 in. OD x 3/8	033215
3l	O-ring-1-3/8 OD x .103W-#23 (50 Per Bag)	018664
4	Line A.-Flare 15"	038299
5	Tube A.-Suction 22" (8752)	X20450
	Tube A.-Suction 18" (8756 and 8757)	X37293
5a	Tube-Vinyl 5/8 ID x 1/8 Wall (8752)	020945-22
	Tube-Vinyl 5/8 ID x 1/8 Wall (8756 and 8757)	020945-18
5b	Counterweight-Suction Tube	020452
6	Line A-Pump Pressure (Includes 6a-6c)	X27139
6a	Socket-QD. 3/16 Barb	020021
6b	Ferrule-3/8 OD Brass	030553
6c	Tube-Vinyl 3/16IDx5/16OD-100 (16")	020940-16
7	Diaphragm-Pressure Switch	020249

OPERATING PROCEDURES

Sanitizing

1. Prepare a pail of approved 100 ppm sanitizing solution (examples: 2-1/2 gal. [9.5 L] of Kay-5[®] or 2 gal. [7.6 L] of Stera-Sheen[®]). Use warm water and follow the manufacturer's specifications.
2. Place the pail of sanitizing solution inside the mix cabinet.
3. Brush-clean the mix inlet tube with the long brush and sanitizing solution.

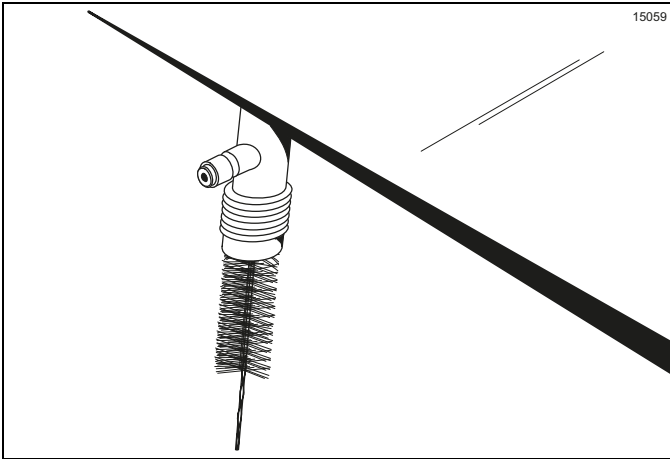

Figure 6-36

4. Connect the free end of the flare line to the threaded fitting on the mix inlet tube.

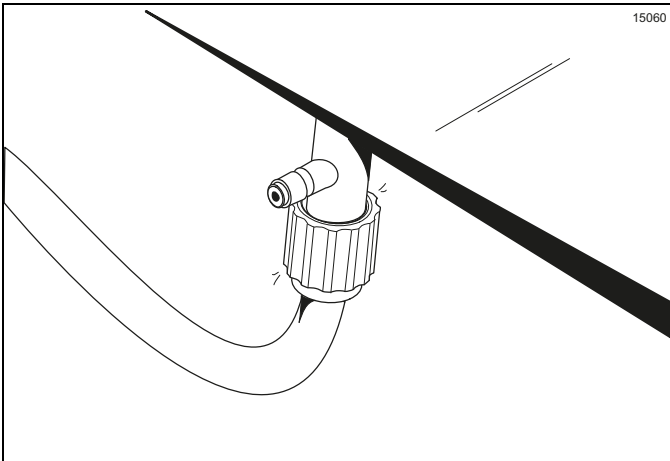

Figure 6-37

5. Install the pressure line. Attach the quick-disconnect fitting of the pressure line to the other fitting on the mix inlet tube just above the flare line and allow the other end to hang free.

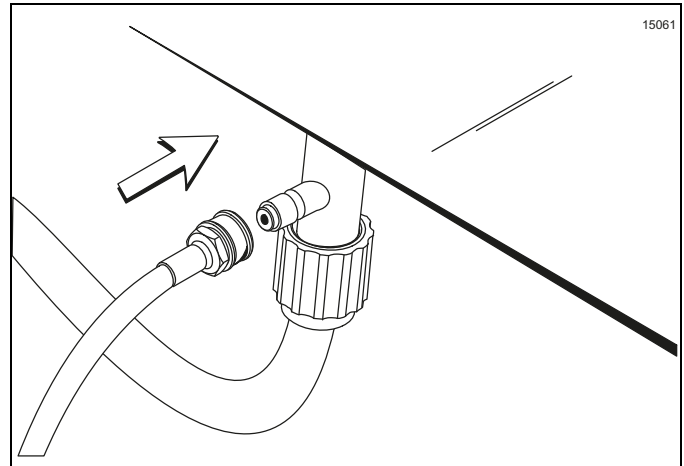

Figure 6-38

6. Insert the free end of the suction line and pressure line into the pail of sanitizing solution.

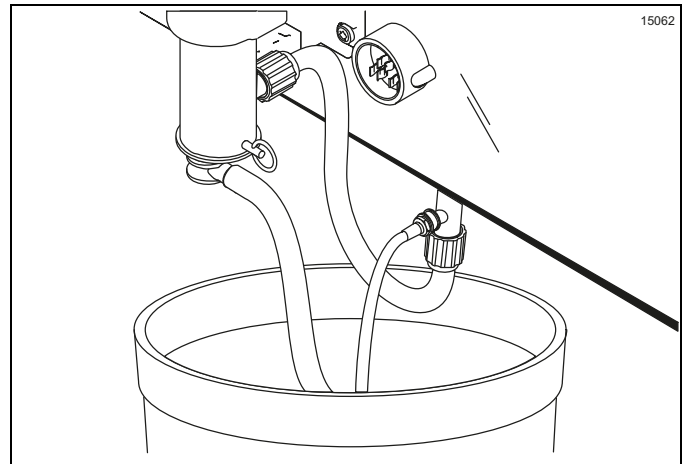

Figure 6-39

7. Place the power switch in the ON position.

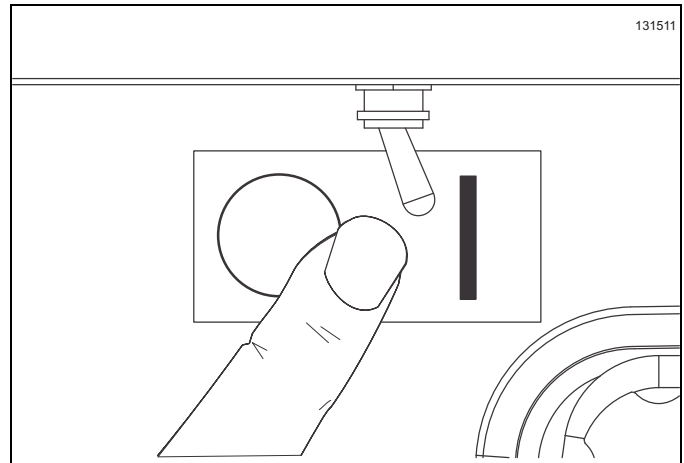

Figure 6-40

- Press the PUMP button. A light will come on, indicating the air/mix pump is operating. This action will cause the sanitizing solution to be pumped through the air/mix pump and out through the pressure line. After approximately 15 seconds, press the PUMP button. The light will go out, and the pump will stop operation.

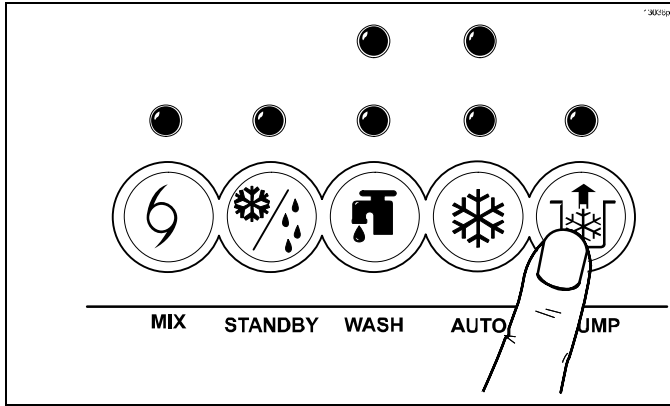

Figure 6-41

- Drain and connect the free end of the pressure line to the pressure switch.

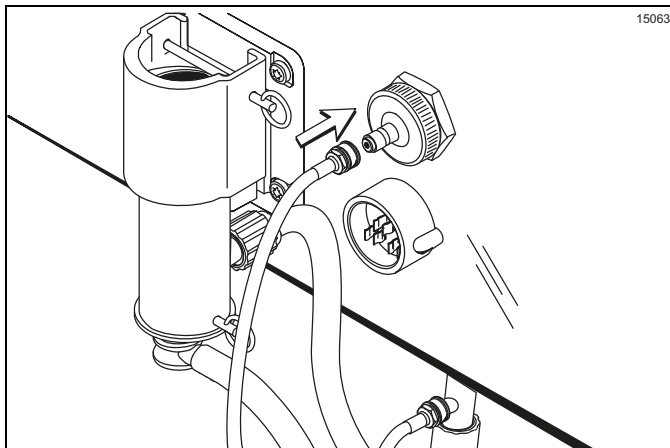

Figure 6-42

- Place an empty pail beneath the door spout. Raise the prime plug.

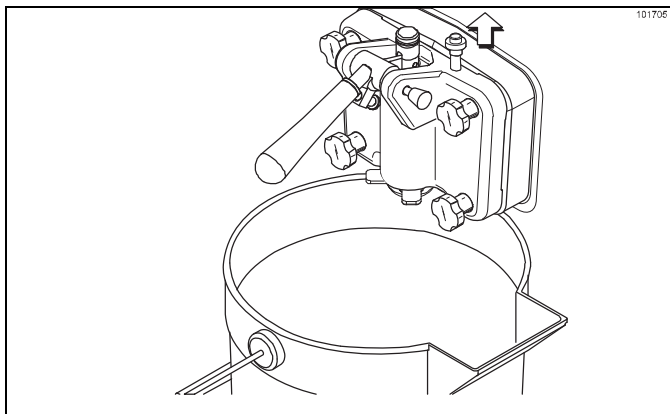

Figure 6-43

- Press the WASH and PUMP buttons. The indicators will light, indicating the pump and beater motor are operating. When a steady stream of sanitizing solution is flowing from the prime plug hole in the bottom of the freezer door, press the PUMP button, stopping pump operation. Push down the prime plug and allow beater agitation for 5 minutes.

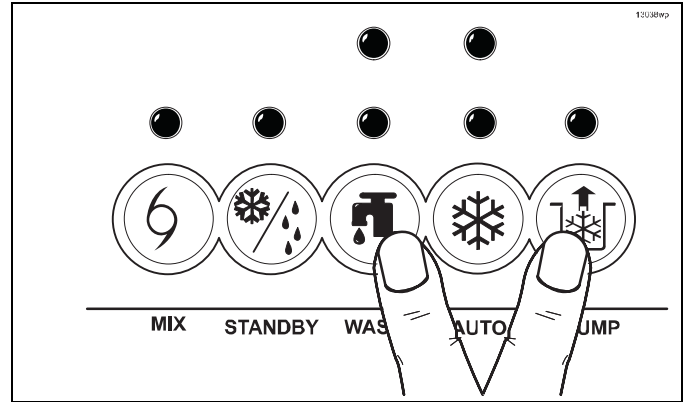

Figure 6-44

- After 5 minutes, open the prime plug. Press the PUMP button. Pull the draw handle down and draw off the remaining sanitizer.

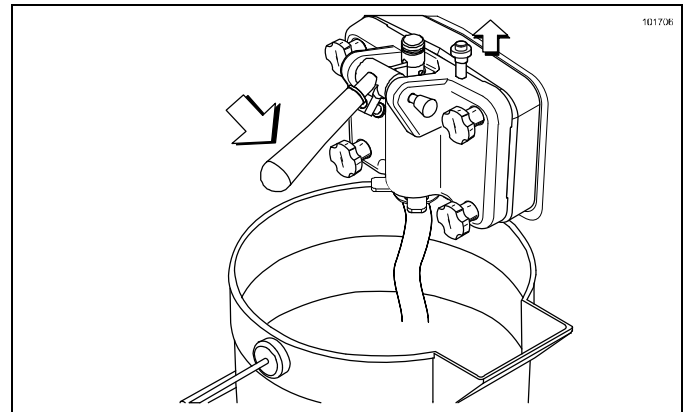

Figure 6-45

- Once the sanitizer stops flowing from the door spout, close the draw valve. Press the PUMP and WASH buttons to stop operation. Disconnect the pressure line from the pressure switch. Drain the sanitizer and reconnect.

Important! The machine must not be placed in Auto mode until all sanitizing solution has been removed from the freezing cylinder and proper priming procedures have been completed. Failure to follow this instruction may result in damage to the freezing cylinder.

Note: On Models 8756 and 8757, momentarily pull down the center draw handle to sanitize the center door spout.

OPERATING PROCEDURES

- Repeat steps 1 through 13 for the second freezing cylinder on Models 8756 and 8757.
- Prepare a sink with an approved sanitizing solution (examples: Stera-Sheen® or Kay-5®). Use warm water and follow the manufacturer's specifications.
- Take the following parts to the sink and sanitize: mix tank(s), mix tank cover(s), mix probe(s), mix storage cover(s) and funnel(s).

Priming

- Sanitize the mix tank, the mix tank cover, the mix probe, the mix storage cover, and the funnel. Place the mix tank and the cover in the mix cabinet.
- Insert the prongs of the mix probe inside the mix tank. Connect the mix probe in the socket receptacle.

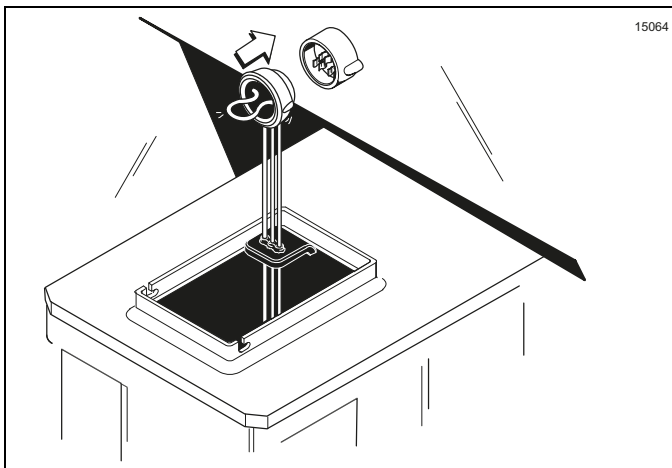

Figure 6-46

- Place the free end of the suction line down in the mix tank.

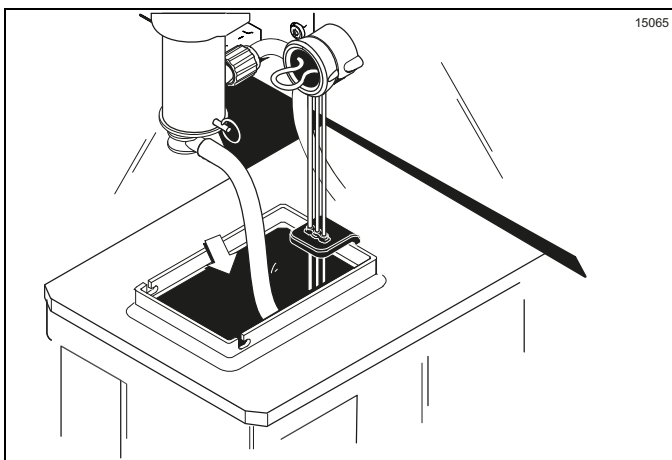

Figure 6-47

Important! Use only **fresh** mix when priming the machine.

- Install the funnel. Fill the mix tank with fresh mix.

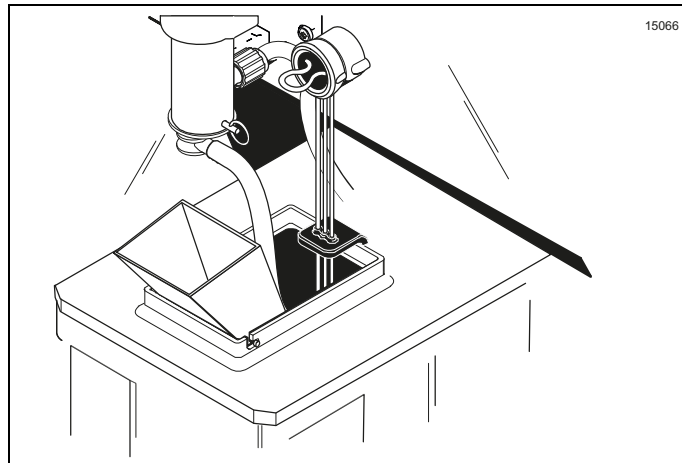

Figure 6-48

- Remove the funnel and install the mix storage cover. Close the mix cabinet door.
- Place an empty pail beneath the door spout and open the draw valve. With the prime plug still in the up position, press the PUMP button. This will allow the mix to be pumped through the freezing cylinder and force out any remaining sanitizer. When full-strength mix is flowing from the door spout, close the draw valve.
- When a steady stream of mix is flowing from the prime plug hole in the bottom of the freezer door, press the PUMP button to stop operation.

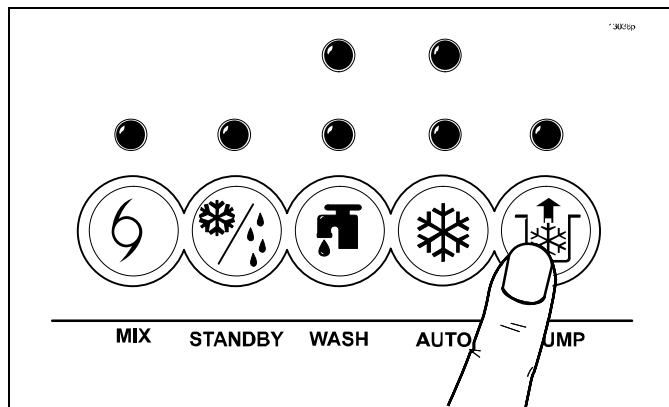

Figure 6-49

- Once the stream of mix stops flowing from the prime plug hole, push down the prime plug. Rinse the prime plug hole area with water. Remove the pail and discard the mix and sanitizer.

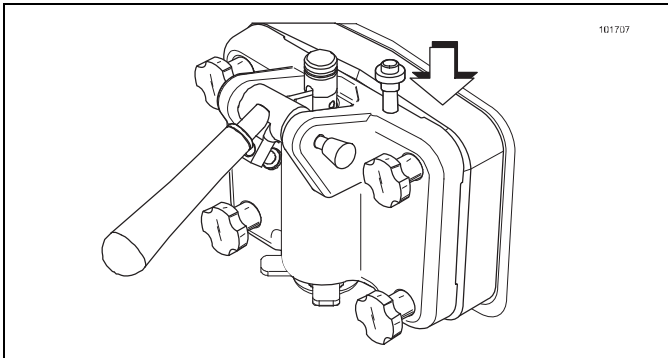

Figure 6-50

Important! Failure to remove all sanitizing solution may result in damage to the freezing cylinder.

- Press the AUTO button. The MIX REF light will come on to indicate the mix refrigeration system is operating. The AUTO light will come on to indicate the main refrigeration system is operating, and the PUMP light will come on to indicate the air/mix pump will operate whenever mix is needed in the freezing cylinder.

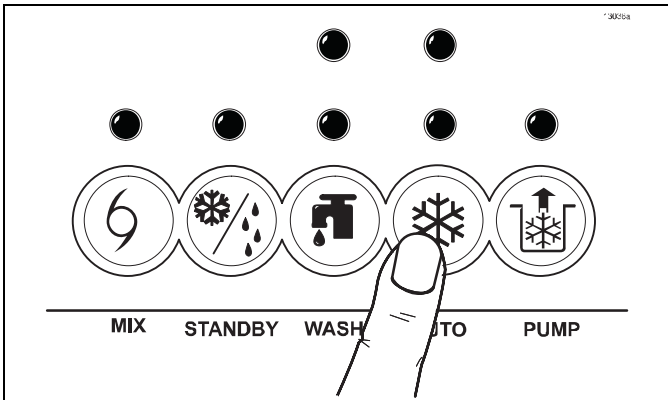

Figure 6-51

Repeat step 1 through step 9 for the other side of the machine on Models 8756 and 8757.

When the machine cycles off, the product will be at the correct viscosity.

Note: Keep the mix cabinet door closed except when filling the mix tank and during the cleaning and sanitizing procedures. Leaving the door open with the mix refrigeration system on may cause the evaporator to ice up and impair the mix cabinet refrigeration.

Closing Procedure

To disassemble Models 8752, 8756, and 8757, the following items will be needed:

- Two cleaning and sanitizing pails
- Sanitized stainless-steel rerun can with lid
- Cleaning brushes (provided with machine)
- Cleaner
- Single-service towels

Draining Product from the Freezing Cylinder

- Press the AUTO and MIX REF buttons to cancel machine operation.
- Open the mix cabinet door and remove the mix storage cover(s), mix probe(s), mix tank cover(s), and mix tank(s). Empty the mix from the mix tank(s) into a sanitized stainless-steel rerun can.
- Place the suction line in an empty pail in the mix cabinet
- If local health codes permit the use of rerun, place a sanitized, NSF-approved stainless-steel rerun container beneath the door spout. Open the draw valve and press the WASH and PUMP buttons. Drain all the mix from the freezing cylinder. When all product stops flowing from the door spout, close the draw valve and press the WASH and PUMP buttons to stop operation. Place the sanitized lid on the rerun container and place it in the walk-in cooler.

Note: If local health codes **do not** permit the use of rerun, the product must be discarded. Follow the instructions in the previous step, except drain product into a pail and properly discard the mix.

Repeat steps 3 and 4 for the second freezing cylinder on Models 8756 and 8757.



FOLLOW YOUR LOCAL HEALTH CODES.

Rinsing

1. Fill the empty pail in the mix cabinet with 2 gal. (7.6 L) of **cool**, clean water. Place the free end of the suction line in the pail of water.
2. Disconnect the pressure line from the pressure switch and place it in the pail of water.
3. Press the PUMP button. This action will cause the rinse water to be pumped through the air/mix pump and out through the pressure line. After approximately 15 seconds, press the PUMP button to stop operation.
4. Drain and connect the free end of the pressure line to the pressure switch.
5. Place an empty pail beneath the door spout. Raise the prime plug and press the WASH and PUMP buttons.
6. When a steady stream of rinse water is flowing from the prime plug hole in the bottom of the freezer door, open the draw valve and drain all the rinse water.
7. Once the rinse water stops flowing from the door spout, close the draw valve and press the WASH and PUMP buttons to stop operation.
8. Disconnect the pressure line from the pressure switch. Drain the water and then reconnect.
9. Repeat this procedure using clean, warm water until the water being discharged is clear.
10. Repeat steps 1 through 9 for the second freezing cylinder on Models 8756 and 8757.

Cleaning

1. Prepare a pail of approved 100 ppm cleaning solution (examples: 2-1/2 gal. [9.5 L] of Kay-5[®] or 2 gal. [7.6 L] of Stera-Sheen[®]). Use warm water and follow the manufacturer's specifications. Place the pail of cleaning solution inside the mix cabinet and insert the suction line.
2. Disconnect the pressure line from the pressure switch and place it in the pail of cleaning solution.

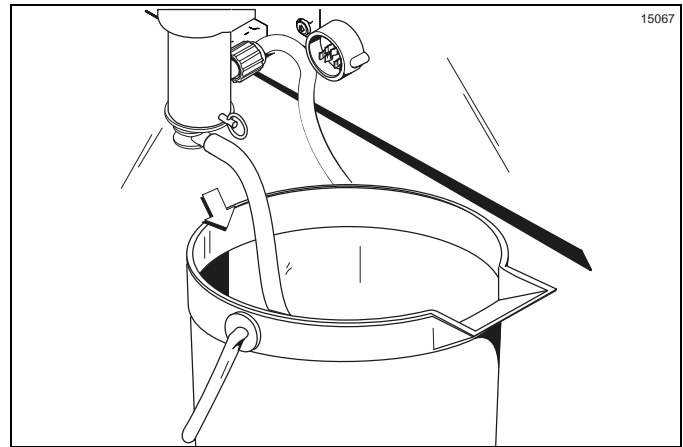

Figure 6-52

3. Press the PUMP button. This action will cause the cleaning solution to be pumped through the air/mix pump and out through the pressure line. After approximately 15 seconds, press the PUMP button to stop operation.
 4. Drain and connect the free end of the pressure line to the pressure switch.
 5. Place an empty pail beneath the door spout, raise the prime plug, and press the WASH and PUMP buttons.
 6. When a steady stream of solution is flowing from the prime plug hole in the bottom of the freezer door, pull down the draw handle and draw off the remaining cleaning solution.
 7. Once the solution stops flowing from the door spout, close the draw valve and press the WASH and PUMP buttons to stop operation.
- Repeat step 1 through step 7** for the other side of the machine on Models 8756 and 8757.
8. Place the power switch in the OFF position before disassembling the machine.

Disassembly



WARNING! Make sure the power switch is in the OFF position. Failure to follow this instruction may result in severe personal injury from hazardous moving parts.

1. Remove the handscrews, freezer door, beater(s), shoes, scraper blades, and driveshaft(s) from the freezing cylinder(s). Take these parts to the sink for cleaning.

2. Remove the air/mix pump. Unscrew the flare line from the mix inlet tube. Disengage the pressure line from the pressure switch and the mix inlet tube. Pull the retaining pin out of the pump collar and slide the collar down. Tilt the air/mix pump away from the machine and take the entire assembly to the sink for further disassembly and brush-cleaning.
3. Remove the pressure switch cap from the mix cabinet. Remove the diaphragm from the cap.
Repeat steps 2 and 3 for the other side of the machine on Models 8756 and 8757.
4. Remove the front drip tray and splash shield.

Brush-Cleaning

1. Prepare a sink with an approved cleaning solution (examples: Kay-5[®] or Stera Sheen[®]). Use warm water and follow the manufacturer's specifications. If an approved cleaner other than Kay-5[®] or Stera- Sheen[®] is used, dilute it according to the label instructions.

Important! Follow the label directions. Too **strong** of a solution can cause parts damage, while too **mild** of a solution will not provide adequate cleaning. Make sure all brushes provided with the machine are available for brush-cleaning.

2. Remove the seal(s) from the driveshaft(s).
3. From the freezer door(s), remove the gasket(s), front bearing(s), pivot pin(s), draw handle(s), draw valve(s), prime plug(s), and design cap(s).
4. Remove all O-rings.

Note: To remove O-rings, use a single-service towel to grasp the O-ring. Apply pressure upwards until the O-ring pops out of its groove. With the other hand, push the top of the O-ring forward. It will roll out of the groove and can be easily removed. If there is more than one O-ring to be removed, always remove the rear O-ring first. This will allow the O-ring to slide over the forward rings without falling into the open grooves.

5. Remove the flare line(s), suction line(s), retaining pin(s), and mix inlet fitting(s) from the pump cylinder(s). Remove the liquid valve body(ies) from the pump cylinder(s).
Remove the piston(s) from the pump cylinder(s).
Remove all O-rings and check bands.

6. Return to the freezer with a small amount of cleaning solution. With the black bristle brush, brush-clean the rear-shell bearing(s) at the back of the freezing cylinder(s).

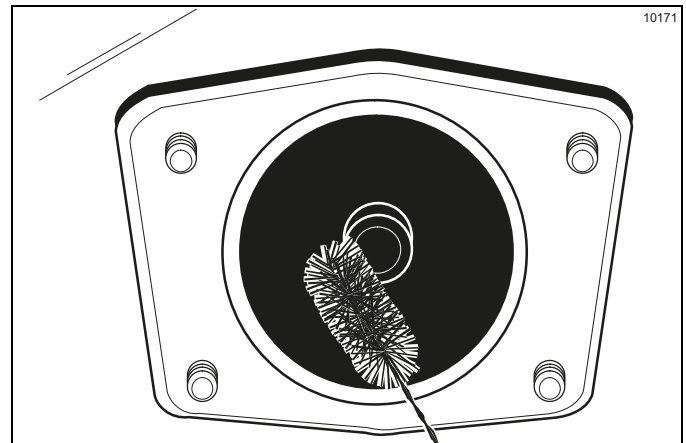

Figure 6-53

7. Using the long, flexible brush and the cleaning solution, clean the mix inlet tube(s) located in the mix cabinet. Thoroughly clean the tube(s) all the way up to the freezing cylinder. This area needs special attention because bacteria and milkstone can build up here.
8. Remove the rear drip pan from the side panel and take it to the sink for cleaning.
Note: If the rear drip pan is filled with an excessive amount of mix, go to the Troubleshooting Guide.
9. Thoroughly brush-clean all disassembled parts in the cleaning solution, making sure all lubricant and mix film is removed. Take particular care to brush-clean the draw valve core(s) in the freezer door. Place all the cleaned parts on a clean, dry surface to air-dry overnight.
10. Wipe clean all exterior surfaces of the freezer and the mix cabinet.

Check Topping Pump Temperature and Volume - Model 8757

To check the topping pump temperature and volume on Model 8757 the following items will be needed:

- Digital thermometer with needle probe
- Calibrating cup
- Flatblade screwdriver
- Sanitizer (examples: Stera Sheen[®] or Kay-5[®])

Note: *This procedure should be performed on a morning after the pumps were disassembled and cleaned, on a monthly basis.*

1. Dispense one serving of topping into a sundae cup.
2. Insert the sanitized needle probe into the topping. Let the probe stabilize for 20 seconds.

Note: *Topping temperature should be between 115°F and 125°F (46°C and 52°C) and must be this temperature before pump calibration can begin. Water bath temperature should be between 135°F and 145°F (57°C and 63°C).*

3. If the temperature is too cold or too warm, it can be adjusted by the temperature control located inside the machine on the back of the topping compartment.
4. Using the flatblade screwdriver, loosen and remove the screws from the lower right panel. Locate the adjustment screws, one for each water bath.
5. Using a flatblade screwdriver, turn the adjustment screw **clockwise** to **increase** and **counterclockwise** to **decrease** the water bath temperature. Adjust in small increments.

6. Allow 10 minutes for the temperature to stabilize in the water bath.
7. Check the temperature again in the water bath.
8. Place the topping pump back into the container.
9. Repeat these steps for the other topping. Install the lower right panel, if applicable, and install the screws.
10. Hold the small chamber of the calibrating cup under the dispensing nozzle.
11. Push the dispensing lever down for one full stroke. The topping should be directed to the bottom of the calibrating cup. **Do Not** allow the topping to fall on the sides of the cup.
Note: *The amount of dispensed topping should be 1 fl. oz. (29.6 ml).*
12. If the dispensed amount is correct, proceed to step 13. If the amount of dispensed topping is not correct, consult the Troubleshooting Section of your machine manual.
13. Repeat steps 10 through 12 for the other topping pump, then proceed with step 14.
14. Topping pump temperature and volume check is complete.

During Cleaning and Sanitizing



FOLLOW YOUR LOCAL ELECTRICAL CODES.



NOTICE! Cleaning and sanitizing schedules are governed by your federal, state, or local regulatory agencies and must be followed accordingly. Please refer to the cleaning section of this manual for the proper procedure to clean this machine.

If the machine has a STANDBY mode, it must not be used instead of proper cleaning and sanitizing procedures and frequencies set forth by the ruling health authority. The following check points should be stressed during the cleaning and sanitizing operations.



IMPORTANT! *Cleaning and sanitizing must be performed daily.*

Troubleshooting Bacterial Count

- Thoroughly clean and sanitize the machine regularly, including complete disassembly and brush-cleaning.
- Use all brushes supplied with the machine for thorough cleaning. The brushes are specially designed to reach all mix passageways.
- Use the long 38 in. (97 cm) white bristle brush to clean the mix feed tube which extends from the mix reservoir to the rear of the freezing cylinder.
- Use the black bristle brush to thoroughly clean the rear shell bearing located at the rear of the freezing cylinder. Use a generous amount of cleaning solution on the brush.
- If the local health codes permit the use of rerun**, make sure the mix rerun is stored in a sanitized, covered stainless-steel container and is used the following day. **Do Not** prime the machine with rerun. When using rerun, skim off the foam and discard, then mix the rerun with fresh mix in a ratio of 50:50 during the day's operation.

- On a designated day of the week, run the mix as low as feasible and discard after closing. This will break the rerun cycle and reduce the possibility of high bacteria and coliform counts.
- Properly prepare the cleaning and sanitizing solutions. Read and follow the label directions carefully. Too **strong** of a solution may damage the parts, and too **mild** of a solution will not do an adequate job of cleaning or sanitizing. Sanitize the freezing cylinder for 5 minutes.
- The temperature of the mix in the mix cabinet and the walk-in cooler should be below 40°F (4.4°C).

Regular Maintenance Checks

- Replace scraper blades that are bent, damaged, or worn.
- Before installing the beater, make sure that the scraper blades are properly attached over the pins and the beater assembly is straight.
- Check the rear-shell bearing for signs of wear (excessive mix leakage in the rear drip pan) and make sure it is properly cleaned.
- Using a screwdriver and cloth towel, clean the rear-shell bearing and the female hex drive socket free of lubricant and mix deposits.
- Dispose of O-rings and seals if they are worn, torn, or fit too loosely, and replace with new ones.
- Follow all lubricating procedures as outlined in "Assembly" on page 6-1.
- If your machine is air-cooled, check the condensers for dirt and lint. Dirty condensers will reduce the efficiency and capacity of the machine. Condensers should be cleaned **monthly** with a soft brush. **Never** use screwdrivers or other metal probes to clean between the fins.

Note: *For machines equipped with an air filter, it will be necessary to vacuum-clean the filters monthly.*

OPERATOR CHECKLIST

- On water-cooled machines, check the water lines for kinks or leaks. Kinks can occur when the machine is moved back and forth for cleaning or maintenance. Deteriorated or cracked water lines should be replaced only by a Taylor technician.
- Your machine is equipped with an auxiliary refrigeration system. Check the auxiliary condenser for dirt and lint. Dirty condensers will reduce the refrigeration capacity of the mix cabinet. Condensers must be cleaned **monthly** with a soft brush.
- Never** use screwdrivers or other metal probes to clean between the fins.

Note: *For machines equipped with an air filter, it will be necessary to vacuum-clean the filters on a monthly.*

Air/Mix Pump

- Dispose of the O-rings, check bands, and the pressure-switch diaphragm if they are worn, torn, or fit too loosely. Replace them with new ones.
- Follow lubricating procedures carefully. **Do not** lubricate check bands.
- Handle plastic pump parts with care to avoid nicks and cracks.
- Make sure the pressure line is securely attached to the pressure switch.
- Clean, sanitize, and lubricate the pressure-switch diaphragm daily.
- Make sure the air/mix pump is properly aligned with the face plate of the motor reducer, or severe and costly damage may occur.

Winter Storage

If the place of business is to be closed during the winter months, it is important to protect the machine by following certain precautions, particularly if the building is subject to freezing conditions.

Disconnect the machine from the main power source to prevent possible electrical damage.

On water-cooled machines, disconnect the water supply. Relieve pressure on the spring in the water valve. Use air pressure on the outlet side to blow out any water remaining in the condenser. **This is extremely important.** Failure to follow this procedure may cause severe and costly damage to the refrigeration system.

Your local Taylor Distributor can perform this service for you.

Wrap detachable parts of the machine (such as the beater, blades, driveshaft, and freezer door) and place these parts in a protected, dry place. Rubber trim parts and gaskets can be protected by wrapping them with moisture-proof paper. All parts should be thoroughly cleaned of dried mix or lubrication, which can attract mice and other vermin.

Table 8-1

Problem	Probable Cause	Remedy	Page Ref.
1. No product is being dispensed.	<ul style="list-style-type: none"> a. Low on mix. The MIX OUT light is on. b. The power switch is in the OFF position. c. The beater motor is out on reset. d. The beater assembly is rotating counterclockwise. e. Insufficient mix in the freezing cylinder. f. Restriction in the door spout. g. Machine is unplugged. h. Circuit breaker is off or the fuse is blown. i. The mix probe was not installed properly or was damaged. 	<ul style="list-style-type: none"> a. Add mix to the mix tank and press the AUTO button. b. Place the power switch in the ON position and press the AUTO button. c. Reset the freezer. d. Contact service technician to correct rotation to clockwise. e. Go to problem 2. f. Remove the draw handle and raise the draw valve all the way up to remove restriction. Never put objects or fingers in door spout. g. Plug machine into the wall receptacle. h. Turn the breaker on or replace the fuse. i. Check the mix probe installation. 	<ul style="list-style-type: none"> 5-1 --- 5-1 --- --- --- --- --- --- 6-12

TROUBLESHOOTING GUIDE

Problem	Probable Cause	Remedy	Page Ref.
2. Insufficient mix in the freezing cylinder.	a. Suction line is not fully submerged in the mix.	a. Arrange the suction line so the weighted end is fully submerged.	6-12
	b. Improper seal of suction line to the mix inlet fitting.	b. Remove the suction line from the mix inlet fitting. Place under hot running water, allow tubing to swell, then cool. Connect suction line to barbed fitting. Eventual replacement will be necessary.	---
	c. Worn or defective check bands or O-rings in air/mix pump assembly.	c. Replace regularly. Do not lubricate check bands.	6-9/9-1
	d. Missing, defective, or no lubrication on the mix inlet fitting O-ring.	d. Replace or evenly lubricate the O-ring on the mix inlet fitting.	6-1/9-1
	e. The mix pump ball crank is broken.	e. Contact a service technician to replace the ball crank.	---
	f. The pump motor is not activated.	f. Place the power switch in the OFF position. Push the RESET button on the pump drive motor. Return the power switch to the ON position. Press the AUTO button. (For Models 8756 and 8757, press the AUTO button for the opposite freezing cylinder also.)	---
	g. Defective air/mix pump pressure switch.	g. Contact a service technician to replace the pressure switch.	---
	h. Pressure-switch diaphragm installed incorrectly or missing.	h. Diaphragm must be correctly installed in the pressure switch cap or the housing.	6-1
	i. The mix inlet tube is frozen or clogged.	i. Use the long flexible brush and sanitizing solution to clear the restriction in the mix inlet tube. Contact a service technician to correct the cause of over-refrigeration in the mix cabinet.	---
	j. The mix pump is pumping foam.	j. Incorrect handling of rerun. Remove all foam.	---
3. Product is too stiff.	a. Viscosity control is set too cold.	a. Contact a service technician.	---
	b. Insufficient mix in the freezing cylinder.	b. Go to problem 2.	---
	c. Improper priming procedures.	c. Drain the freezing cylinder and reprime the machine.	6-12
	d. Out-of-date mix.	d. Use fresh mix. When using rerun, skim off the foam and mix 50% rerun with 50% fresh mix during heavy draw periods.	6-13/9-1

Problem	Probable Cause	Remedy	Page Ref.
4. Product is too soft.	<ul style="list-style-type: none"> a. Viscosity control is set too warm. b. Worn scraper blades. c. Dirty condensers or air filters on air-cooled machines. d. Inadequate water supply on water-cooled machines. e. Draw rate is set too fast f. Inadequate air space around air-cooled machines. 	<ul style="list-style-type: none"> a. Contact a service technician. b. Replace scraper blades regularly. c. Clean monthly. d. Check the water supply. Check water lines for leaks or kinks. e. Adjust the draw rate to 5 to 7-1/2 oz. of product every 10 seconds. Check that the restrictive bar on the draw handle is assembled on the bottom. f. Allow adequate room for air flow across the condensers; minimum of 3 in. (7.6 cm) clearance on all sides. Do not obstruct air discharge on the top of the freezer. Allow 12 in. (30.5 cm) clearance on the top of the freezer. 	<ul style="list-style-type: none"> --- 9-1 7-1 1-2/7-1 1-2
5. Mix in the mix cabinet is too warm.	<ul style="list-style-type: none"> a. Warm mix was placed in the tank. b. The mix cabinet door was left open. c. The mix cabinet refrigeration system needs adjustment. d. The mix cabinet door gasket is not sealing. e. Dirty mix cabinet condenser or air filter. 	<ul style="list-style-type: none"> a. Mix added to the mix tank should be below 40°F (4.4°C). b. The door must be kept closed. c. Contact a service technician. d. Repair or replace gasket. e. Clean monthly. 	<ul style="list-style-type: none"> 7-1 6-13 --- --- 7-1
6. Mix in the mix cabinet is too cold.	<ul style="list-style-type: none"> a. The mix cabinet refrigeration system needs adjustment. 	<ul style="list-style-type: none"> a. Contact a service technician. 	
7. Excessive mix leakage from the bottom of the door spout.	<ul style="list-style-type: none"> a. Worn, missing, or incorrect O-ring is on the draw valve. b. Improper lubrication on the draw valve O-rings. 	<ul style="list-style-type: none"> a. Check the O-rings. (Replace every 3 months.) b. Lubricate properly. 	<ul style="list-style-type: none"> 9-1 6-2
8. Excessive mix leakage into the rear drip pan.	<ul style="list-style-type: none"> a. Worn or missing driveshaft seal. b. Improper lubrication of the driveshaft. c. Worn rear-shell bearing. d. The gearbox is out of alignment. 	<ul style="list-style-type: none"> a. Install or replace the seal. b. Lubricate properly. c. Contact a service technician to replace the rear-shell bearing. d. Contact a service technician to align the gearbox. 	<ul style="list-style-type: none"> 6-1/9-1 6-1 --- ---
9. The driveshaft is stuck in the gearbox coupling.	<ul style="list-style-type: none"> a. The gear box is out of alignment. b. Rounded corners on hex end of driveshaft or gear coupling. 	<ul style="list-style-type: none"> a. Contact a service technician to align the gear box. b. Replace damaged component. 	<ul style="list-style-type: none"> --- ---

TROUBLESHOOTING GUIDE

Problem	Probable Cause	Remedy	Page Ref.
10.The freezing cylinder walls are scored.	a. The scraper blades are damaged.	a. Replace the scraper blades.	6-1
	b. The front bearing is missing or worn on the freezer door.	b. Install or replace the front bearing.	6-1
	c. Machine was placed in AUTO before all sanitizing solution was removed from freezing cylinder.	c. Place machine in AUTO only after priming is complete and all sanitizing solution is removed.	6-12/6-13
	d. Broken pins on beater assembly.	d. Repair or replace the beater assembly. Make sure the scraper blades are properly seated on pins.	6-2
	e. The beater assembly is bent.	e. Call service technician to repair or replace the beater and to correct the cause of insufficient mix in the freezing cylinder.	---
11.The air/mix pump does not operate.	a. The pump motor is not activated.	a. Place the power switch in the OFF position. Push the RESET button on the pump drive motor. Return the power switch to the ON position. (On Models 8756 and 8757, press the AUTO button for the opposite freezing cylinder also.)	---
	b. Defective air/mix pump pressure switch.	b. Contact a service technician to replace the pressure switch.	---
	c. The pressure-switch diaphragm was installed incorrectly or was missing.	c. The diaphragm must be correctly installed in the pressure-switch cap or housing.	6-1
12.The machine will not operate in the AUTO mode.	a. The machine is unplugged.	a. Plug the machine into the wall receptacle.	---
	b. The circuit breaker is off or the fuse is blown.	b. Turn the breaker on or replace the fuse.	---
	c. Low on mix. The MIX OUT light is flashing.	c. Add mix to the mix tank and press the AUTO button.	5-1
	d. The mix probe is not installed properly or is damaged.	d. Check the mix-probe installation.	6-12
	e. The beater motor is out on reset.	e. Reset the freezer.	5-1
	f. The machine is off on high head pressure.	f. Air-cooled machines: clean the condenser. Water-cooled: check the water supply. Contact a service technician.	7-1
	g. The power switch is in the OFF position.	g. Place the power switch in the ON position.	6-10

Section 9

Parts Replacement Schedule

Table 9-1

Part Description	Every 3 Months	Every 4 Months	Every 6 Months	Annually	Qty.
Scraper Blades		X			2*
Driveshaft Seal	X				1*
Freezer Door Gasket	X				1*
Front Bearing	X				1*
Beater Shoes	X				2*
Draw Valve O-ring	X				2**
Prime Plug O-ring	X				2*
Pivot Pin O-ring	X				1*
Air/Mix Pump O-ring	X				4*
Liquid Valve Body Check Band	X				3*
Mix Inlet Fitting O-ring	X				1*
Pressure-Switch Diaphragm	X				1*
Design Cap	X				1**
White Bristle Brush, 9/16 in. x 44 in. (14 mm x 1.12 m)			Inspect and replace if necessary.	Minimum	1
White Bristle Brush, 1 in. x 2 in. (25 mm x 51 mm)			Inspect and replace if necessary.	Minimum	1
White Bristle Brush, 3 in. x 7 in. (76 mm x 178 mm)			Inspect and replace if necessary.	Minimum	1
White Bristle Brush, 3 in. x 1/2 in. (76 mm x 13 mm)			Inspect and replace if necessary.	Minimum	1
Small White Bristle Brush			Inspect and replace if necessary.	Minimum	1
Double-Ended Brush			Inspect and replace if necessary.	Minimum	1
Black Bristle Brush, 1 in. x 2 in. (25 mm x 51 mm)			Inspect and replace if necessary.	Minimum	1

* Double quantity for Models 8756 and 8757

** Triple quantity for Models 8756 and 8757

TAYLOR COMPANY LIMITED WARRANTY ON FREEZERS

Taylor Company is pleased to provide this limited warranty on new Taylor-branded freezer products available from Taylor to the market generally (the "Product") to the original purchaser only.

LIMITED WARRANTY

Taylor warrants the Product against failure due to defect in materials or workmanship under normal use and service as follows. All warranty periods begin on the date of original Product installation. If a part fails due to defect during the applicable warranty period, Taylor, through an authorized Taylor distributor or service agency, will provide a new or remanufactured part, at Taylor's option, to replace the failed defective part at no charge for the part. Except as otherwise stated herein, these are Taylor's exclusive obligations under this limited warranty for a Product failure. This limited warranty is subject to all provisions, conditions, limitations, and exclusions listed below and on the reverse (if any) of this document.

Table 10-1

Product	Part	Limited Warranty Period
Soft Serve	Insulated shell assembly	Five (5) years
Frozen Yogurt	Refrigeration compressor (except service valve)	Five (5) years
Shakes		
Smoothies	Beater motors	Two (2) years
Frozen Beverage	Beater drive gear	Two (2) years
Batch Desserts	Printed circuit boards and Softech™ controls beginning with serial number H8024200	Two (2) years
	Parts not otherwise listed in this table or excluded below	One (1) year

LIMITED WARRANTY CONDITIONS

1. If the date of original installation of the Product cannot be verified, then the limited warranty period begins ninety (90) days from the date of Product manufacture (as indicated by the Product serial number). Proof of purchase may be required at time of service.
2. This limited warranty is valid only if the Product is installed and all required service work on the Product is performed by an authorized Taylor distributor or service agency, and only if genuine, new Taylor parts are used.
3. Installation, use, care, and maintenance must be normal and in accordance with all instructions contained in the Taylor Operator's Manual.
4. Defective parts must be returned to the authorized Taylor distributor or service agency for credit.
5. The use of any refrigerant other than that specified on the Product's data label will void this limited warranty.

LIMITED WARRANTY EXCEPTIONS

This limited warranty does **not** cover:

1. Labor or other costs incurred for diagnosing, repairing, removing, installing, shipping, servicing, or handling of defective parts, replacement parts, or new Products.
2. Normal maintenance, cleaning, and lubrication as outlined in the Taylor Operator's Manual, including cleaning of condensers.
3. Replacement of wear items designated as Class "000" parts in the Taylor Operator's Manual.

MACHINE LIMITED WARRANTY

4. External hoses, electrical power supplies, and machine grounding.
5. Parts not supplied or designated by Taylor, or damages resulting from their use.
6. Return trips or waiting time required because a service technician is prevented from beginning warranty service work promptly upon arrival.
7. Failure, damage, or repairs due to faulty installation, misapplication, abuse, no or improper servicing, unauthorized alteration, or improper operation or use as indicated in the Taylor Operator's Manual, including but not limited to the failure to use proper assembly and cleaning techniques, tools, or approved cleaning supplies.
8. Failure, damage or repairs due to theft, vandalism, wind, rain, flood, high water, water, lightning, earthquake, or any other natural disaster, fire, corrosive environments, insect or rodent infestation, or other casualty, accident or condition beyond the reasonable control of Taylor; operation above or below the electrical or water supply specification of the Product; or components repaired or altered in any way so as, in the judgment of the Manufacturer, to adversely affect performance, or normal wear or deterioration.
9. Any Product purchased over the Internet.
10. Failure to start due to voltage conditions, blown fuses, open circuit breakers, or damages due to the inadequacy or interruption of electrical service.
11. Electricity or fuel costs, or increases in electricity or fuel costs from any reason whatsoever.
12. Damages resulting from the use of any refrigerant other than that specified on the Product's data label will void this limited warranty.
13. Any cost to replace, refill, or dispose of refrigerant, including the cost of refrigerant.
14. **ANY SPECIAL, INDIRECT, OR CONSEQUENTIAL PROPERTY OR COMMERCIAL DAMAGE OF ANY NATURE WHATSOEVER.** Some jurisdictions do not allow the exclusion of incidental or consequential damages, so this limitation may not apply to you.

This limited warranty gives you specific legal rights, and you may also have other rights which vary from jurisdiction to jurisdiction.

LIMITATION OF WARRANTY

THIS LIMITED WARRANTY IS EXCLUSIVE AND IS IN LIEU OF ALL OTHER WARRANTIES, CONDITIONS, AND/OR REMEDIES UNDER THE LAW, INCLUDING ANY IMPLIED WARRANTIES OR CONDITIONS OF MERCHANTABILITY OR FITNESS FOR A PARTICULAR PURPOSE. THE ORIGINAL OWNER'S SOLE REMEDY WITH RESPECT TO ANY PRODUCTS SHALL BE REPAIR OR REPLACEMENT OF DEFECTIVE COMPONENTS UNDER THE TERMS OF THIS LIMITED WARRANTY. ALL RIGHTS TO CONSEQUENTIAL OR INCIDENTAL DAMAGES (INCLUDING CLAIMS FOR LOST SALES, LOST PROFITS, PRODUCT LOSS, PROPERTY DAMAGES, OR SERVICE EXPENSES) ARE EXPRESSLY EXCLUDED. THE EXPRESS WARRANTIES MADE IN THIS LIMITED WARRANTY MAY NOT BE ALTERED, ENLARGED, OR CHANGED BY ANY DISTRIBUTOR, DEALER, OR OTHER PERSON, WHATSOEVER.

LEGAL REMEDIES

The owner **must** notify Taylor in writing, by certified or registered letter to the following address, of any defect or complaint with the Product, stating the defect or complaint and a specific request for repair, replacement, or other correction of the Product under warranty, mailed at least thirty (30) days before pursuing any legal rights or remedies.

Taylor Company
750 N. Blackhawk Blvd.
Rockton, IL 61072, U.S.A.

TAYLOR COMPANY LIMITED WARRANTY ON TAYLOR GENUINE PARTS

Taylor Company is pleased to provide this limited warranty on new Taylor genuine replacement components and parts available from Taylor to the market generally (the “Parts”) to the original purchaser only.

LIMITED WARRANTY

Taylor warrants the Parts against failure due to defect in materials or workmanship under normal use and service as follows. All warranty periods begin on the date of original installation of the Part in the Taylor machine. If a Part fails due to defect during the applicable warranty period, Taylor, through an authorized Taylor distributor or service agency, will provide a new or remanufactured Part, at Taylor’s option, to replace the failed defective Part at no charge for the Part. Except as otherwise stated herein, these are Taylor’s exclusive obligations under this limited warranty for a Part failure. This limited warranty is subject to all provisions, conditions, limitations, and exclusions listed below and on the reverse (if any) of this document.

Table 11-1

Parts Warranty Class Code or Part	Limited Warranty Period
Class 103 Parts ¹	Three (3) Months
Class 212 Parts ²	Twelve (12) Months
Class 512 Parts	Twelve (12) Months
Class 000 Parts	No Warranty
Taylor Part #072454 (Motor-24VDC *C832/C842*)	Four (4) years

LIMITED WARRANTY CONDITIONS

1. If the date of original installation of the Part cannot be otherwise verified, proof of purchase may be required at time of service.
2. This limited warranty is valid only if the Part is installed and all required service work in connection with the Part is performed by an authorized Taylor distributor or service agency.
3. The limited warranty applies only to Parts remaining in use by their original owner at their original installation location in the machine of original installation.
4. Installation, use, care, and maintenance must be normal and in accordance with all instructions contained in the Taylor Operator’s Manual.
5. Defective Parts must be returned to the authorized Taylor distributor or service agency for credit.
6. This warranty is not intended to shorten the length of any warranty coverage provided pursuant to a separate Taylor Limited Warranty on freezer or grill machines.
7. The use of any refrigerant other than that specified for the machine in which the Part is installed will void this limited warranty.

^{1, 2} Except that Taylor Part #032129SER2 (Compressor-Air-230V SERV) and Taylor Part #075506SER1 (Compressor-Air-115V 60HZ) shall have a limited warranty period of twelve (12) months when used in Taylor freezer and a limited warranty period of two (2) years when used in Taylor grill machines.

LIMITED WARRANTY ON PARTS

LIMITED WARRANTY EXCEPTIONS

This limited warranty does **not** cover:

1. Labor or other costs incurred for diagnosing, repairing, removing, installing, shipping, servicing, or handling of defective Parts, replacement Parts, or new Parts.
2. Normal maintenance, cleaning, and lubrication as outlined in the Taylor Operator's Manual, including cleaning of condensers or carbon and grease buildup.
3. Required service, whether cleaning or general repairs, to return the cooking surface assemblies, including the upper platen and lower plate, to an operational condition to achieve proper cooking, or allow proper assembly of release sheets and clips as a result of grease buildup on the cooking surfaces, including but not limited to the platen and plate, sides of the shroud, or top of the shroud.
4. Replacement of cooking surfaces, including the upper platen and lower plate, due to pitting or corrosion (or in the case of the upper platen, due to loss of plating) as a result of damage due to the impact of spatulas or other small wares used during the cooking process or as a result of the use of cleaners, cleaning materials, or cleaning processes not approved for use by Taylor.
5. Replacement of wear items designated as Class "000" Parts in the Taylor Operator's Manual, as well as any release sheets and clips for the Product's upper platen assembly.
6. External hoses, electrical power supplies, and machine grounding.
7. Parts not supplied or designated by Taylor, or damages resulting from their use.
8. Return trips or waiting time required because a service technician is prevented from beginning warranty service work promptly upon arrival.
9. Failure, damage, or repairs due to faulty installation, misapplication, abuse, no or improper servicing, unauthorized alteration or improper operation or use as indicated in the Taylor Operator's Manual, including but not limited to the failure to use proper assembly and cleaning techniques, tools, or approved cleaning supplies.
10. Failure, damage or repairs due to theft, vandalism, wind, rain, flood, high water, water, lightning, earthquake, or any other natural disaster, fire, corrosive environments, insect or rodent infestation, or other casualty, accident or condition beyond the reasonable control of Taylor; operation above or below the gas, electrical, or water supply specification of the machine in which a part is installed; or Parts or the machine in which they are installed repaired or altered in any way so as, in the judgment of Taylor, to adversely affect performance, or normal wear or deterioration.
11. Any Part purchased over the Internet.
12. Failure to start due to voltage conditions, blown fuses, open circuit breakers, or damages due to the inadequacy or interruption of electrical service.
13. Electricity, gas, or other fuel costs, or increases in electricity or fuel costs from any reason whatsoever.
14. Damages resulting from the use of any refrigerant other than that specified for the machine in which the Part is installed will void this limited warranty.
15. Any cost to replace, refill, or dispose of refrigerant, including the cost of refrigerant.
16. **ANY SPECIAL, INDIRECT, OR CONSEQUENTIAL PROPERTY OR COMMERCIAL DAMAGE OF ANY NATURE WHATSOEVER.** Some jurisdictions do not allow the exclusion of incidental or consequential damages, so this limitation may not apply to you.

This limited warranty gives you specific legal rights, and you may also have other rights which vary from jurisdiction to jurisdiction.

LIMITATION OF WARRANTY

THIS LIMITED WARRANTY IS EXCLUSIVE AND IS IN LIEU OF ALL OTHER WARRANTIES, CONDITIONS, AND/OR REMEDIES UNDER THE LAW, INCLUDING ANY IMPLIED WARRANTIES OR CONDITIONS OF MERCHANTABILITY OR FITNESS FOR A PARTICULAR PURPOSE. THE ORIGINAL OWNER'S SOLE REMEDY WITH RESPECT TO ANY PRODUCTS SHALL BE REPAIR OR REPLACEMENT OF DEFECTIVE PARTS UNDER THE TERMS OF THIS LIMITED WARRANTY. ALL RIGHTS TO CONSEQUENTIAL OR INCIDENTAL DAMAGES (INCLUDING CLAIMS FOR LOST SALES, LOST PROFITS, PRODUCT LOSS, PROPERTY DAMAGES, OR SERVICE EXPENSES) ARE EXPRESSLY EXCLUDED. THE EXPRESS WARRANTIES MADE IN THIS LIMITED WARRANTY MAY NOT BE ALTERED, ENLARGED, OR CHANGED BY ANY DISTRIBUTOR, DEALER, OR OTHER PERSON, WHATSOEVER.

LEGAL REMEDIES

The owner **must** notify Taylor in writing, by certified or registered letter to the following address, of any defect or complaint with the Part, stating the defect or complaint and a specific request for repair, replacement, or other correction of the Part under warranty, mailed at least thirty (30) days before pursuing any legal rights or remedies.

Taylor Company
750 N. Blackhawk Blvd.
Rockton, IL 61072, U.S.A.

